

Galveston County Proposal #B151018

Project 09-012a

March 28, 2015

Fueling Station Crystal Beach Campus

Galveston County, Texas

County Commissioners

The Honorable Mark HenryCounty Judge
The Honorable Ryan DennardCommissioner Precinct 1
The Honorable Joe GiustiCommissioner Precinct 2
The Honorable Stephen D. HolmesCommissioner Precinct 3
The Honorable Ken ClarkCommissioner Precinct 4

Galveston County Proposal #B151018

Project 09-012a

Fueling Station Crystal Beach Campus

TABLE OF CONTENTS

March 28, 2015

Proposal Documents

Request for Proposals 1-2
Proposal Documents 1
General Provisions 1-20

Special Provisions

Special Provisions 1
Proposal Form 1-5
Sample Evaluation Form 1
Drawing Sheet 1 1 page
Drawing Sheet 2 1 page
Drawing Sheet 4 1 page
E1.0 for information only 1 page
A0.1 for information only 1 page
C1.0 for information only 1 page
Fuel Force 894-K 2 pages
ConVault 1 page
Agreement between Galveston County and Contractor 1-13
General Conditions of the Contract 1-32

Galveston County Proposal #B151018

Project 09-012a

Fueling Station.....Crystal Beach Campus

REQUEST FOR PROPOSALS

Galveston County is requesting proposals for design-build services of the fueling system at the new Crystal Beach Road and Bridge Facility on Bolívar Peninsula. All proposers are required to include a Licensed Engineering Firm with the State of Texas and a Licensed UST Contactor with the TCEQ to provide both engineering services and a fueling system installation compliant with all Federal, State and Local regulations.

This is a turnkey project. It includes all permits and operational training for a fully operating fueling station before it is complete and turned over to Galveston County.

The site has been prepared under a separate contract. Prospective proposers shall visit the site to become familiar with the existing conditions.

This fueling station shall be connected to other buildings on the campus (the Eddie Barr Annex and the Road and Bridge Facility) for power and tele communications. Coordination of all electric and tele communication connectivity is the responsibility of this proposal.

The proposal should include the engineering (design) and installation of the following fueling equipment and construction:

- One - ConVault 2,000 Gallon Aboveground Storage Tank for unleaded gasoline service.
- One - connection for future 3,000 Gallon aboveground storage tank for diesel service
- Two – ¾ Horsepower Submersible Pumps
- One – Fuel Management System – Fuel Force fully coordinated and integrated into the City of Galveston system (the County of Galveston uses the City of Galveston system and this station will be an extension of that program)
- Two – Product Dispensers with pulsars, all stainless steel panels, hose and nozzle assemblies, external filters and internal lighting.
- One – Automatic Tank Gauge System with inventory probes, interstice and sump leak sensors
- One – Building approximately 8 foot square to house and secure the fuel system controllers. The building is to be constructed of painted 8” split face CMU with wood framed roof and overhangs to replace the original structure but at a more flood resistant elevation.
- Double wall fiberglass underground piping and single wall welded steel aboveground piping with dispenser and transition sumps.
- All necessary Tank and Piping apparatuses
- Federal, State and Local Code Compliant Fueling System Design and Installation
- Spill Prevention, Control and Countermeasure (SPCC) Plan
- All Labor, Material and Installation
- Stainless steel doors with card key access integrated with the existing County wide system of card key access.
- Fiber optic connection to the County network hub in the Eddie Barr Annex (approximately 700 lf of underground conduit and necessary length of cable- verify length in the field) - The cabling shall be OSP rated, 12 strand, 62.5 micron, multimode fiber to connect the buildings together. Another contract will provide fiber trays for each end as well as the SC patch ports. Provide a total of four (4) fiber pairs terminated by this contract.
- Fiber Optic connection to Road and Bridge Facility via existing conduit to the tele/data closet in the new Road and Bridge Facility (approximately 300 lf – verify length in the field) - The cabling shall be OSP rated, 12 strand, 62.5 micron, multimode fiber to connect the buildings together. Another contract will provide fiber trays for each end as well as the SC patch ports. Provide a total of four (4) fiber pairs terminated by this contract.
- One Year Warranty from date of acceptance
- Additional information is provided on the attached drawing sheets 1 through 4.

Galveston County Proposal #B151018

Project 09-012a

Fueling Station.....Crystal Beach Campus

- Drawings from the Road and Bridge Facility project are also attached and provided for the benefit of the proposer in preparing a proposal. Actual site conditions may vary from drawings C1.0 Civil Site Plan, A0.1 Site Plan, and E0.1 Site Power Plan. A full set of Road and Bridge documents may be viewed on the County web site upon request.

Sealed proposals in sets of six (6), one (1) original and five (5) copies will be received in the office of the County Purchasing Agent, until **10:00 A.M.** on **April 30,2015** and publically opened as soon as practical after proposal time in that office in the presence of the County Auditor and the Purchasing Agent. **Proposers are specifically advised that any Proposal delivered after this time will be returned unopened.**

Proposer must seal all proposals in an opaque envelope with the following information on the face of the envelope and deliver to:

**Proposal #B151018
Crystal Beach Fueling Station**

To:

Galveston County Purchasing Agent
722 Moody (21st Street) - 5th Floor
Galveston, Texas 77550

From:

Name of Proposer

Each proposal must be accompanied by a Certified or Cashier's Check or acceptable Proposer (Bid) Bond in the amount of 5% of Proposal as a guarantee that, if awarded the contract the Proposer will enter into a contract and execute required Performance and Payment Bonds.

No proposal shall be withdrawn within sixty (60) days after proposal date without the specific consent of Galveston County.

**Design Professional: Galveston County Architect
J. Dudley Anderson
722 Moody
Galveston, Texas 77550
(409) 770-5330**

Galveston County may reject any proposal not prepared and submitted in accordance with the provisions hereof and may waive any and all informalities, reject any and all proposals and accept any proposal deemed in its best interest or otherwise advantageous to it.

Upon satisfaction of contractual terms (e.g., goods delivered in promised condition, services rendered as agreed, etc.), vendor is to be paid after certification by the Construction Manager agent and Architect via Galveston County's normal accounts payable process.

Rufus Crowder, CPPO CPPB
Purchasing Agent
Galveston County

Galveston County Proposal #B151018

Project 09-012a

Fueling Station.....Crystal Beach Campus

PROPOSAL DOCUMENTS

Proposer may obtain an electronic copy of the plans and specifications in pdf format at the Galveston County Purchasing Agent's office.

Proposal Documents will be available prior to proposal date and may be obtained at the following address:

Proposals Documents available at:

The Office of the County Purchasing Agent
722 Moody (21st Street) - 5th Floor
Galveston, Texas 77550

Office Hours are 8:00 AM to 5:00 PM

PAYMENT BOND AND PERFORMANCE BOND: A Payment Bond and Performance Bond, each in an amount equal to or greater than 100% of the Contract Sum conditioned upon the faithful performance of the Contract will be required. Please note that all bonding companies presented must be acceptable to Galveston County.

PRE-PROPOSAL MEETING: No pre-proposal meeting is scheduled, however all proposers are required to have visited the site and become familiar with the existing conditions. The site visit is part of the evaluation criteria and failure to visit the site will be considered during the evaluation process.

QUALIFICATION: Proposer is required to comply with certain procedures as enumerated in the Instructions to Proposer regarding qualification of Proposer.

Any proposer submitting a proposal is required to visit the site.

**Crystal Beach Fueling Station
GALVESTON COUNTY, TEXAS**

Table of Contents

GENERAL PROVISIONS:

1.	PROPOSAL PACKAGE	1
2.	PROPOSER’S RESPONSIBILITY.....	1
3.	TIME FOR RECEIVING PROPOSALS	1
4.	PROPOSAL OPENING	1
5.	COMMISSIONERS’ COURT	1
6.	REJECTION OF PROPOSALS/DISQUALIFICATION	2
	A.Failure to use the proposal form(s) furnished by the County;.....	2
7.	RESTRICTIVE OR AMBIGUOUS SPECIFICATIONS	2
8.	SUBSTITUTES/DESCRIPTION OF MATERIALS AND EQUIPMENT.....	2
9.	EXCEPTIONS TO PROPOSAL.....	2
10.	PRICING	3
11.	PROCUREMENT CARD PROGRAM.....	3
12.	PASS THROUGH COST ADJUSTMENTS	3
13.	MODIFICATION OF PROPOSALS	3
14.	SIGNATURE OF PROPOSALS	4
15.	AWARD OF PROPOSALS – EVALUATION CRITERIA AND FACTORS.....	4
16.	DISPUTE AFTER AWARD/PROTEST	5
17.	PUBLIC INFORMATION ACT.....	5
18.	PROPOSER’S EMAIL ADDRESSES	5
19.	RESULTANT CONTRACT	5
20.	CONTRACT TERM	6
21.	TERMINATION FOR DEFAULT	6
22.	TERMINATION FOR CONVENIENCE	6
23.	FORCE MAJEURE	7
24.	ESTIMATED QUANTITIES	7
25.	CONTRACTOR INVESTIGATION	7
26.	NO COMMITMENT BY COUNTY OF GALVESTON	7

**Crystal Beach Fueling Station
GALVESTON COUNTY, TEXAS**

27.	PROPOSAL COSTS BORNE BY BIDDER/PROPOSER	7
28.	BEST AND FINAL OFFERS (BAFO).....	7
29.	SINGLE PROPOSAL RESPONSE	8
30.	CHANGES IN SPECIFICATIONS	8
31.	PROPOSAL IDEAS AND CONCEPTS	8
32.	PROPOSAL DISCLOSURES	8
33.	WITHDRAWAL OF PROPOSAL	8
34.	INDEMNIFICATION	8
35.	REQUIREMENT OF AND PROOF OF INSURANCE	9
36.	PROPOSAL GUARANTEE	10
37.	PERFORMANCE AND PAYMENT BONDS	10
38.	PATENT AND COPYRIGHT PROTECTION	11
39.	CONFLICT OF INTEREST DISCLOSURE REPORTING	11
40.	COMPETITIVENESS AND INTEGRITY	12
41.	ENTIRETY OF AGREEMENT AND MODIFICATION	13
42.	NON-COLLUSION AFFIDAVIT	13
43.	SOVEREIGN IMMUNITY	13
44.	CONTROLLING LAW AND VENUE	13
45.	MERGERS, ACQUISITIONS	14
46.	DELAYS	14
47.	ACCURACY OF DATA.....	14
48.	SUBCONTRACTING/ASSIGNMENT.....	14
49.	INDEPENDENT CONTRACTOR.....	14
50.	MONITORING PERFORMANCE	14
51.	PROCUREMENT ETHICS.....	15
52.	SUBJECT TO APPROPRIATION OF FUNDS.....	16
53.	NOTICE	16
54.	NONDISCRIMINATION.....	17
55.	RECORD RETENTION AND RIGHT TO AUDIT.....	18
56.	TITLE VI ASSURANCES/TxDOT	18

Crystal Beach Fueling Station
GALVESTON COUNTY, TEXAS

57. CERTIFICATION REGARDING DEBARMENT, SUSPENSION, PROPOSED DEBARMENT, AND OTHER
RESPONSIBILITY MATTERS 19

58. SECTION 231.006, FAMILY CODE/DELINQUENT CHILD SUPPORT..... 20

59. LABOR STANDARDS..... 20

SPECIAL PROVISIONS.....1-13

GENERAL PROVISIONS
Crystal Beach Fueling Station
GALVESTON COUNTY, TEXAS

1. PROPOSAL PACKAGE:

The request for proposal, general and special provisions, drawings, specifications/line item details, contract documents and the proposal sheet are all part of the proposal package. Proposals must be submitted in sets of five (5), one (1) original and four (4) copies on the forms provided by the County, including the proposal sheets completed in their entirety and signed by an authorized representative by original signature. Failure to complete and sign the proposal sheets/contract page(s) may disqualify the proposal from being considered by the Commissioners' Court. Any individual signing on behalf of the proposer expressly affirms that he or she is duly authorized to tender this proposal and to sign the proposal sheet/contract under the terms and conditions in this proposal. Proposer further understands that the signing of the contract shall be of no effect unless subsequently awarded and the contract properly executed by the Commissioners' Court. All figures must be written in ink or typed. Figures written in pencil or with erasures are not acceptable. However, mistakes may be crossed out, corrections inserted, and initialed in ink by the individual signing the proposal. If there are discrepancies between unit prices quoted and extensions, the unit price will prevail. Each proposer is required to thoroughly review this entire proposal packet to familiarize themselves with the proposal procedures, the plans and specifications for the requested work as well as the terms, and conditions of the contract the successful proposer will execute with the County.

2. PROPOSER'S RESPONSIBILITY

The Proposer must affirmatively demonstrate its responsibility. The Proposer must also meet the following minimum requirements:

- A. have adequate financial resources or the ability to obtain such resources as required;
- B. be able to comply with all federal, state, and local laws, rules, regulations, ordinances and orders regarding this Request for Proposal;
- C. have a satisfactory record of performance;
- D. have a satisfactory record of integrity and ethics;
- E. and be otherwise qualified and eligible to receive an award.

3. TIME FOR RECEIVING PROPOSALS:

Proposals received prior to the submission deadline will be maintained unopened until the specified time for opening. If the proposer fails to identify the Proposal Number on the outside of the envelope as required, the Purchasing Agent will open the envelope for the sole purpose of identifying the proposal number for which the submission was made. The envelope will then be resealed. No liability will attach to a County office or employee for the premature opening of a proposal. If you do not submit a proposal, return this Request for Proposal and state reason, otherwise your name may be removed from the Purchasing Agent's mailing list.

4. PROPOSAL OPENING:

Only the names of proposers will be read at the opening. The Purchasing Agent will examine proposals promptly and thoroughly. No proposal may be withdrawn for a period of sixty (60) calendar days of the proposal opening date.

5. COMMISSIONERS' COURT:

No contract is binding on the County until it is properly placed on the Commissioners' Court agenda, approved in open Court, authorized to be executed by the County Judge, and fully executed by both parties. Department heads and elected officials are not authorized to enter into any type of agreement or contract on behalf of the County. Only the Commissioners' Court acting as a body may enter into a contract on behalf of and contractually bind the County. Additionally, department heads and elected officials are not authorized to agree to any type of supplemental agreements or contracts for goods or services. Supplemental agreements are subject to review by the County Legal Department prior to being accepted and signed by the County's authorized representative.

GENERAL PROVISIONS
Crystal Beach Fueling Station
GALVESTON COUNTY, TEXAS

6. REJECTION OF PROPOSALS/DISQUALIFICATION:

Galveston County, acting through its Commissioners' Court, reserves the right to: reject any and all proposals in whole or in part received by reason of this request for proposal, to waive any informality in the proposals received, to disregard the proposal of any proposer determined to be not responsible, and/or to discontinue its efforts for any reason under this proposal package at any time prior to actual execution of contract by the County. Proposers may be disqualified and rejection of proposals may be recommended to the Commissioners' Court for any of (but not limited to) the following causes:

Failure to use the proposal form(s) furnished by the County;

- A. Lack of signature by an authorized representative on the proposal form(s);
- B. Failure to properly complete the proposal;
- C. Proposals that do not meet the mandatory requirements; and/or;
- D. Evidence of collusion among proposers.

7. RESTRICTIVE OR AMBIGUOUS SPECIFICATIONS:

It is the responsibility of the prospective proposer to review the entire invitation to proposal packet and to notify the Purchasing Department if the specifications are formulated in a manner that would restrict competition or appear ambiguous. Any protest or question(s) regarding the specifications or proposal procedures must be received in the Purchasing Department not less than seventy-two (72) hours prior to the time set for proposal opening. Vendors are to submit proposal as specified herein or propose an approved equal.

8. SUBSTITUTES/DESCRIPTION OF MATERIALS AND EQUIPMENT:

Any brand name or manufacturer reference used herein is intended to be descriptive and not restrictive, unless otherwise noted, and is used to indicate the type and quality of material. The term "or equal" if used, identifies commercially produced items that have the essential performance and salient characteristics of the brand name stated in the item description. All supplies, material, or equipment shall be new and of the most suitable grade for the purpose intended. It is not the County's intent to discriminate against any materials or equipment of equal merit to those specified. However, if Proposer desires to use any substitutions, prior written approval must be obtained from the County Purchasing Agent and sufficiently in advance such that an addendum may be issued. All material supplied must be one hundred percent (100%) asbestos free. Bidder/Proposer, by submission of its bid/proposal, certifies that if awarded any portion of this procurement, the bidder/proposer will supply only material and equipment that is 100% asbestos free.

9. EXCEPTIONS TO PROPOSAL:

The proposer will list on a separate sheet of paper any exceptions to the conditions of the proposal. This sheet will be labeled, "Exceptions to Proposal Conditions", and will be attached to the proposal. If no exceptions are stated, it will be understood that all general and specific conditions will be complied with, without exception.

The Proposer must specify in its proposal any alternatives it wishes to propose for consideration by the County. Each alternative should be sufficiently described and labeled within the proposal and should indicate its possible or actual advantage to the program being offered.

The County reserves the right to offer these alternatives to other proposers.

The remainder of this page intentionally left blank

GENERAL PROVISIONS
Crystal Beach Fueling Station
GALVESTON COUNTY, TEXAS

10. PRICING:

Proposals will be either lump sum or unit prices as shown on the proposal sheet. The net price will be delivered to Galveston County, including all freight or shipping charges. Cash discount must be shown on proposal, otherwise prices will be considered net. Unless prices and all information requested are complete, proposal may be disregarded and given no consideration. In case of default by the contractor, the County of Galveston may procure the articles or services from other sources and may deduct from any monies due, or that may thereafter become due to the contractor, the difference between the price named in the contract of purchase order and the actual cost thereof to the County of Galveston. Prices paid by the County of Galveston shall be considered the prevailing market price at the time such purchase is made. Periods of performance may be extended if the facts as to the cause of delay justify such extension in the opinion of the Purchasing Agent and the Commissioners' Court.

11. PROCUREMENT CARD PROGRAM:

The County of Galveston participates in a Procurement Card (P-Card) program that allows payments made to a vendor by credit card. This method normally results in substantially faster bill payments, sometimes within three (3) to five (5) days of the actual transaction date. If your company will accept payment via credit card (Visa, MasterCard), please notate this in your proposal submittal.

12. PASS THROUGH COST ADJUSTMENTS:

Except in instances of extreme extenuating circumstances Contractor prices shall remain firm throughout the Contract period and any renewals. Examples of extreme extenuating circumstances include such situations as a nationwide rail strike, oil shortage or oil embargo.

In extreme extenuating circumstances, Contractors may be allowed to temporarily "pass through" additional costs they are forced to incur through no fault of their own. A request for a pass through cost increase will not be considered unless a Contractor's cost for his product exceeds 10% over the original cost for the product. Also, the increase in cost must be nationwide and consistent for a minimum period of sixty (60) days. Costs that historically are anticipated to rise over a period of time (for example only, such as wages or insurance costs) do not qualify for pass through. If a Contractor thinks he will be asking for a pass through cost adjustment during the term of the contract, then the original cost of the product to Contractor must be stated in Contractor's original proposal.

A request for a pass through cost does not guarantee that one will be granted. Contractors must submit such information on each request as is required by the County Purchasing Agent. The County Purchasing Agent will review each request on a case-by-case basis and determine the appropriateness of each request as well as amount and duration of increase. Contractors will not be permitted any additional compensation for mark-ups or profits based on the increase in price. Rather, such additional compensation will be limited to the actual increase in original cost to the Contractor as such increase is reflected by the original cost stated in the proposal. But in no event will the amount of additional compensation exceed 25% increase in Contractor's original cost for his product as such cost is reflected in Contractor's original proposal or the duration exceed a period of sixty (60) days. In addition, should, during the period of the pass through, cost return to normal or decrease to below pre pass through prices, appropriate downward adjustments will be made. No more than one pass through adjustment will be permitted per year.

13. MODIFICATION OF PROPOSALS:

A proposer may modify a proposal by letter at any time prior to the submission deadline for receipt of proposals. Modification requests must be received prior to the submission deadline. Modifications made before opening time must be initialed by proposer guaranteeing authenticity. Proposals may not be amended or altered after the official opening with the single exception that any product literature and/or supporting data required by the actual specifications, if any, will be accepted at any time prior to the Commissioners' Court considering of same.

**GENERAL PROVISIONS
Crystal Beach Fueling Station
GALVESTON COUNTY, TEXAS**

14. SIGNATURE OF PROPOSALS:

Each proposal shall give the complete mailing address of the Proposer and be signed by an authorized representative by original signature with the authorized representative's name and legal title typed below the signature line. Each proposal shall include the Proposer's Federal Employer Identification Number (FEIN). Failure to sign the Contract page(s) and proposal response sheets may disqualify the proposal from being considered by the County. The person signing on behalf of the Proposer expressly affirms that the person is duly authorized to tender the proposal and to sign the proposal sheets and contract under the terms and conditions of this RFP and to bind the Proposer thereto and further understands that the signing of the contract shall be of no effect until it is properly placed on the Commissioners' Court agenda, approved in open Court, authorized to be executed by the County Judge, and fully executed by both parties.

15. AWARD OF PROPOSALS – EVALUATION CRITERIA AND FACTORS:

The award will be made to the responsible proposer whose proposal is determined to be the best evaluated offer demonstrating the best ability to fulfill the requirements set forth in this Request for Proposal. **The proposed cost to the County will be considered firm and cannot be altered after the submission deadline, unless the County invokes its right to request a best and final offer.**

Each proposer, by submitting a proposal, agrees that if their proposal is accepted by the Commissioners' Court, such proposer will furnish all items and services upon which prices have been tendered and upon the terms and conditions in this proposal and contract.

The contractor shall commence work only after the transmittal of a fully executed contract and after receiving written notification to proceed from the County Purchasing Agent. The contractor will perform all services indicated in the proposal in compliance with this contract.

Neither department heads nor elected officials are authorized to sign any binding contracts or agreements prior to being properly placed on the Commissioners' Court agenda and approved in open court. Department heads and other elected officials are not authorized to enter into any type of agreement or contract on behalf of Galveston County. Only the Commissioners' Court, acting as a body, may enter into a contract on behalf of the County. Additionally, department heads and other elected officials are not authorized to agree to any type of supplemental agreements or contracts for goods or services. Supplemental agreements are subject to review by the County Legal Department prior to being signed by the County's authorized representatives.

The County of Galveston reserves the right to accept proposals on individual items listed, or group items, or on the proposal as a whole; to reject any and all proposals; to waive any informality in the proposals; and to accept the proposal that appears to be in the best interest of the County. The selection process may, however, include a request for additional information or an oral presentation to support the written proposal.

In determining and evaluating the best proposal, the pricing may not necessarily be controlling, but quality, equality, efficiency, utility, general terms, delivery, suitability of the service offered, and the reputation of the service in general use will also be considered with any other relevant items. The Commissioners' Court shall be the sole judge in the determination of these matters.

The County reserves the right to reject any or all proposals in whole or in part received by reason of this RFP and may discontinue its efforts under this RFP for any reason or no reason or solely for the County's convenience at any time prior to actual execution of the contract by the County.

A Proposer whose proposal does not meet the mandatory requirements set forth in this RFP will be considered non-compliant.

GENERAL PROVISIONS
Crystal Beach Fueling Station
GALVESTON COUNTY, TEXAS

The invitation to submit a proposal which appears in the newspaper, or other authorized advertising mediums, these general provisions, the specifications which follow, the proposal sheets, and any addenda issued are all considered part of the proposal.

Each Proposer, by submitting a proposal, agrees that if its proposal is accepted by the Commissioners' Court, such Proposer will furnish all items and services upon the terms and conditions in this RFP and the resultant contract.

Notice of contract award will be made within ninety (90) days of opening of proposals to the lowest responsive and responsible contractor, whose proposal complies with all the requirements in the Request for Proposals.

Contractor shall submit to the County, for approval, within ten (10) days from notice of contract award, all Certificates of Insurance evidencing the required coverage as described under Insurance in the schedule of the Requests for Proposals.

The contractor shall not commence work under these terms and conditions of the contract until all applicable Certificates of Insurance, Performance and Payment Bonds, and Irrevocable Letter of Credit (if required) have been approved by the County of Galveston and the Contractor has received notice to proceed in writing and an executed copy of the contract from the County Purchasing Agent.

16. DISPUTE AFTER AWARD/PROTEST:

Any actual or prospective Proposer who is allegedly aggrieved in connection with the solicitation of this RFP or award of a contract resulting therefrom may protest. The protest will be submitted in writing to the Purchasing Agent within seven (7) calendar days after such aggrieved person knows of or should have known of the facts giving rise thereto. If the protest is not resolved by mutual agreement, the Purchasing Agent will promptly issue a decision in writing to the protestant. If the protestant wishes to appeal the decision rendered by the Purchasing Agent, such appeal must be made to the Commissioners' Court through the Purchasing Agent. The decision of the Commissioners' Court will be final. The Commissioners' Court need not consider protests unless this procedure is followed.

17. PUBLIC INFORMATION ACT:

The parties agree that the County is a governmental body for purposes of the Public Information Act, codified as Chapter 552 of the Texas Government Code and as such is required to release information in accordance with the Public Information Act. Proposer agrees that it has **clearly and conspicuously** marked any information that it considers to be confidential, proprietary, and/or trade secret in its proposal. County agrees to provide notice to Proposer in accordance with the Public Information Act in the event the County receives a request for information under the Public Information Act for information that the Proposer has marked as confidential, proprietary, and/or trade secret.

18. PROPOSER'S EMAIL ADDRESSES:

Notwithstanding the foregoing Section 17, Proposer acknowledges and agrees that the confidentiality of any and all email addresses it uses or discloses in communicating with the County are open to the public in accordance with Section 552.137 of the Government Code and consents to the release of its email addresses.

19. RESULTANT CONTRACT:

Proposer shall correctly and fully execute the resultant contract first. After this, the contract shall be set for consideration by the Commissioners' Court. If the Commissioners' Court authorizes the execution of the contract, then the resultant contract shall become effective upon the Commissioners' Court execution of same. Contract documents shall consist of the contract, the general and special provisions, the drawings, proposal package (including best and final offer(s) if such is utilized), any addenda issued, and any change orders issued during the work.

GENERAL PROVISIONS
Crystal Beach Fueling Station
GALVESTON COUNTY, TEXAS

If applicable to the attached bid/proposal, bidder/proposer must sign three (3) original contracts and return with their bid/proposal submittal.

Proposer should submit a proposed contract with its proposal or its sample material terms and conditions.

The criteria utilized for determining responsibility of proposer(s) includes, but is not limited to, the proposer's experience, skill, ability, business judgment, financial capacity, integrity, honesty, possession of the necessary facilities or equipment, previous performance, reputation, promptness, and any other factor deemed relevant by the County. The proposers shall furnish any information requested by the County in order for the County to determine whether a proposer is responsible.

20. CONTRACT TERM:

The term of the resultant contract will begin on the date of execution by the Commissioners' Court and will terminate on the date specified in the resultant contract unless terminated earlier as herein set forth.

21. TERMINATION FOR DEFAULT:

Failure of either party in the performance of any of the provisions of this contract shall constitute a breach of contract, in which case either party may require corrective action within ten (10) days from date of receipt of written notice citing the exact nature of such breach. Failure of the party being notified to take corrective action within the prescribed ten (10) days, or failure to provide written reply of why no breach has occurred, shall constitute a Default of Contract.

All notices relating to default by Proposer of the provisions of the contract shall be issued by County by its Legal Department, and all replies shall be made in writing to the County Legal Department. Notices issued by or issued to anyone other than the County Legal Department shall be null and void and shall be considered as not having been issued or received.

Galveston County reserves the right to enforce the performance of this contract in any manner prescribed by law in the event of breach or default of this contract, and may contract with another party, with or without solicitation of bids or proposals or further negotiations. At a minimum, Proposer shall be required to pay any difference in service or materials, should it become necessary to contract with another source, plus reasonable administrative costs and attorney fees.

In the event of Termination for Default, Galveston County, its agents or representatives shall not be liable for loss of any profits anticipated to be made by Proposer.

In addition to the remedies stated herein, the County has the right to pursue other remedies permitted by law or in equity.

No waiver by either party of any event of default under this agreement shall operate as a waiver of any subsequent default under the terms of this agreement.

County reserves the right to terminate this contract immediately in the event Proposer:

- A. Fails to meet delivery or completion schedules; and/or
- B. Fails to otherwise perform in accordance with the accepted proposal and the contract.

22. TERMINATION FOR CONVENIENCE:

County may terminate this contract upon at least thirty (30) calendar days prior written notice for its convenience or for any reason deemed by the County to serve the public interest. County may terminate this contract upon thirty (30) calendar days prior written notice for any reason resulting from any governmental law, order, ordinance, regulations,

GENERAL PROVISIONS
Crystal Beach Fueling Station
GALVESTON COUNTY, TEXAS

or court order. In no event shall County be liable for loss of any profits anticipated to be made hereunder by Proposer should this contract be terminated early.

23. FORCE MAJEURE:

If by reason of Force Majeure either Party shall be rendered unable, wholly or in part, to carry out its responsibilities under this contract by any occurrence by reason of Force Majeure, then the Party unable to carry out its responsibility shall give the other Party notice and full particulars of such Force Majeure in writing within a reasonable time after the occurrence of the event, and such notice shall suspend the Party's responsibility for the continuance of the Force Majeure claimed, but for no longer period.

Force Majeure means acts of God, floods, hurricanes, tropical storms, tornadoes, earthquakes, or other natural disasters, acts of a public enemy, acts of terrorism, sovereign conduct, riots, civil commotion, strikes or lockouts, and other causes that are not occasioned by either Party's conduct which by the exercise of due diligence the Party is unable to overcome and which substantially interferes with operations.

24. ESTIMATED QUANTITIES:

Any reference to quantities shown in the Request for Proposals is an estimate only. Since the exact quantities cannot be predetermined, the County reserves the right to adjust quantities as deemed necessary to meet its requirements.

25. CONTRACTOR INVESTIGATION:

Before submitting a proposal, each proposer shall make all investigations and examinations necessary to ascertain all site conditions and requirements affecting the full performance of the contract and to verify any representations made by the County upon which the contractor will rely. If the contractor receives an award as a result of its proposal submission, failure to have made such investigations and examinations will in no way relieve the contractor from its obligation to comply in every detail with all provisions and requirements of the contract, nor will a plea of ignorance of such conditions and requirements be accepted as a basis for any claim whatsoever by the contractor for additional compensation.

26. NO COMMITMENT BY COUNTY OF GALVESTON:

This Request for Proposal does not commit the County of Galveston to award any costs or pay any costs, or to award any contract, or to pay any costs associated with or incurred in the preparation of a proposal in response to this Request for Proposal, and does not commit the County of Galveston to procure or contract for services or supplies.

27. PROPOSAL COSTS BORNE BY BIDDER/PROPOSER:

Galveston County shall not be liable for any costs incurred by Bidder/Proposer in preparation, production, or submission of a bid/proposal and shall not be liable for any work performed by Bidder/Proposer prior to issuance of fully executed contract and properly issued notice to proceed. Galveston County shall not be liable for any costs incurred by Bidder/Proposer by reason of attending a pre-proposal conference. Galveston County shall not be liable for any costs incurred by Bidder/Proposer by reason of the County invoking use of best and final offers.

28. BEST AND FINAL OFFERS (BAFO):

In acceptance of proposals, the County of Galveston reserves the right to negotiate further with one or more of the proposers as to any features of their proposals and to accept modifications of the work and price when such action will be in the best interest of the County. This includes solicitation of a Best and Final Offer from one or more of the proposers. If invoked, this allows acceptable proposers the opportunity to amend, change or supplement their original proposal. Proposers may be contacted in writing requesting that they submit their Best and Final Offer. Any such Best and Final Offer must include discussed and negotiated changes.

GENERAL PROVISIONS
Crystal Beach Fueling Station
GALVESTON COUNTY, TEXAS

29. SINGLE PROPOSAL RESPONSE:

If only one proposal is received in response to the Request for Proposal, a detailed cost proposal may be requested of the single contractor. A cost/price analysis and evaluation and/or audit may be performed of the cost proposal in order to determine if the price is fair and reasonable.

30. CHANGES IN SPECIFICATIONS:

If it becomes necessary to revise any part of this proposal, a written notice of such revision will be provided to all proposers in the form of addenda. The County is not bound by any oral representations, clarifications, or changes made in the written specifications by the County's employees, unless such clarification or change is provided to proposers in a written addendum from the Purchasing Agent.

The County of Galveston reserves the right to revise or amend the specifications up to the time set for opening of proposals. Such revisions and amendments, if any, shall be announced by amendments to the solicitation. Copies of such amendments shall be furnished to all prospective contractors. Prospective contractors are defined as those contractors listed on the County's Request for Proposal list for this material/service or those who have obtained documents subsequent to the advertisement. If revisions and amendments require changes in quantities or prices proposed, or both, the date set for opening of proposals may be postponed by such number of days as in the opinion of the County shall enable contractors to revise their proposals. In any case, the proposal opening shall be at least five working days after the last amendment, and the amendment shall include an announcement of the new date if applicable, for the opening of proposals.

31. PROPOSAL IDEAS AND CONCEPTS:

The County reserves to itself the right to adopt or use for its benefit, any concept, plan, or idea contained in any proposal.

32. PROPOSAL DISCLOSURES:

The names of those who submitted proposals will not be made public information unless in conformity with the County Purchasing Act. No pricing or staffing information will be released. Proposers are requested to withhold all inquiries regarding their proposal or other submissions until after an award is made. No communication is to be had with any County employee or official, other than the County Purchasing Agent, regarding whether a proposal was received. Violations of this provision may result in the rejection of a proposal.

33. WITHDRAWAL OF PROPOSAL:

Proposers may request withdrawal of a sealed proposal prior to the scheduled proposal opening time provided the request for withdrawal is submitted to the Purchasing Agent in writing. No proposals may be withdrawn for a period of sixty (60) calendar days after opening of the proposals.

34. INDEMNIFICATION:

The contractor shall agree to assume all risks and responsibility for, and agrees to indemnify, defend, and save harmless, the County of Galveston, its elected and appointed officials and department heads, and its agents and employees from and against all claims, demands, suits, actions, recoveries, judgments, and costs and expenses including reasonable attorney's fees for the defense thereof in connection therewith on account of the loss of life, property or injury or damage to the person which shall arise from contractor's operations under this contract, its use of County facilities and/or equipment or from any other breach on the part of the contractor, its employees, agents or any person(s), in or about the County's facilities with the expressed or implied consent of the County. Contractor shall pay any judgment with cost which may be obtained against Galveston County resulting from contractor's operations under this contract.

**GENERAL PROVISIONS
Crystal Beach Fueling Station
GALVESTON COUNTY, TEXAS**

Contractor agrees to indemnify and hold the County harmless from all claims of subcontractors, laborers incurred in the performance of this contract. Contractor shall furnish satisfactory evidence that all obligations of this nature herein above designated have been paid, discharged or waived. If Contractor fails to do so, then the County reserves the right to pay unpaid bills of which County has written notice direct and withhold from Contractor's unpaid compensation a sum of money reasonably sufficient to liquidate any and all such lawful claims.

35. REQUIREMENT OF AND PROOF OF INSURANCE:

The successful proposer shall furnish evidence of insurance to the County Purchasing Agent and shall maintain such insurance as required hereunder or as may be required in the Special Provisions or resultant contract, if different. Contractor shall obtain and thereafter continuously maintain in full force and effect, commercial general liability insurance, including but not limited to bodily injury, property damage, and contractual liability, with combined single limits as listed below or as may be required by State or Federal law, whichever is greater.

- A. For damages arising out of bodily injury to or death of one person in any one accident :
ONE HUNDRED THOUSAND AND NO/100 (\$100,000.00) DOLLARS.
- B. For damages arising out of bodily injury to or death of two or more persons in any one accident:
THREE HUNDRED THOUSAND AND NO/100 (\$300,000.00) DOLLARS.
- C. For any injury to or destruction of property in any one accident :
ONE HUNDRED THOUSAND AND NO/100 (\$100,000.00) DOLLARS.

Insurance shall be placed with insurers having an A.M. Best's rating of no less than A. Such insurance must be issued by a casualty company authorized to do business in the State of Texas, and in standard form approved by the Board of Insurance Commissioners of the State of Texas, with coverage provisions insuring the public from loss or damage that may arise to any person or property by reason of services rendered by Contractor.

Galveston County shall be listed as the additional insured on policy certificates and shall be provided with no less than thirty (30) calendar days prior notice of any changes to the policy during the contractual period.

Certificates of Insurance, fully executed by a licensed representative of the insurance company written or countersigned by an authorized Texas state agency, shall be filed with the County Purchasing Agent within ten (10) business days of issuance of notification from the County Purchasing Agent to Proposer that the contract is being activated as written proof of such insurance and further provided that proposer shall not commence work under this contract until it has obtained all insurance required herein, provided written proof as required herein, and received written notice to proceed issued from the County Purchasing Agent.

Proof of renewal/replacement coverage shall be provided upon expiration, termination, or cancellation of any policy. Said insurance shall not be cancelled, permitted to expire, or changed without thirty (30) days prior written notice to the County.

Insurance required herein shall be maintained in full force and effect during the life of this contract and shall be issued on an occurrence basis. Contractor shall require that any and all subcontractors that are not protected under the Contractor's own insurance policies take and maintain insurance of the same nature and in the same amounts as required of Contractor and provide written proof of such insurance to Contractor. Proof of renewed/replacement coverage shall be provided upon expiration, termination, or cancellation of any policy. Contractor shall not allow any subcontractor to commence work on the subcontract until such insurance required for the subcontractor has been obtained and approved.

GENERAL PROVISIONS
Crystal Beach Fueling Station
GALVESTON COUNTY, TEXAS

Workers' Compensation Insurance: Successful proposer shall carry in full force Workers' Compensation Insurance Policy(ies), if there is more than one employee, for all employees, including but not limited to full time, part time, and emergency employees employed by the successful proposer. Current insurance certificates certifying that such policies as specified above are in full force and effect shall be furnished by successful proposer to the County.

Insurance is to be placed with insurers having a Best rating of no less than A. The Proposer shall furnish the County with certificates of insurance and original endorsements affecting coverage required by these insurance clauses within ten (10) business days of receiving notification from the County Purchasing Agent that the contract is being activated. The certificates and endorsements for each insurance policy are to be signed by a person authorized by the insurer to bind coverage on its behalf. The Proposer shall be required to submit annual renewals for the term of this contract prior to expiration of any policy.

In addition to the remedies stated herein, the County has the right to pursue other remedies permitted by law or in equity.

The County agrees to provide Proposer with reasonable and timely notice of any claim, demand, or cause of action made or brought against the County arising out of or related to utilization of the property. Proposer shall have the right to defend any such claim, demand, or cause of action at its sole cost and expense and within its sole and exclusive discretion. The County agrees not to compromise or settle any claim or cause of action arising out of or related to the utilization of the property without the prior written consent of the Proposer.

In no event shall the County be liable for any damage to or destruction of any property belonging to the Proposer.

36. PROPOSAL GUARANTEE:

Unless specified differently within the Special Provisions of this procurement, each Proposer shall be required to submit a bid guarantee with its proposal as required within this Section

Evidencing its firm commitment to engage in contract if Proposer is selected for award of contract, each Proposer is required to furnish with their proposal a Cashier's Check, or an acceptable proposer's bond (in the event of requests for bids, this is called a Bidder's Bond/Bid Bond), in the amount of five percent (5%) of the total contract price. If Proposer is using a bond, then the Proposer's Bond must be executed with a surety company authorized to do business in the State of Texas. Failure to furnish the bid/proposal guarantee in the proper form and amount, by the time set for opening of bids/proposals may be cause for rejection of the bid/proposal.

The Cashier's Check or Proposer/Bid Bond (as applicable) will be returned to each respective unsuccessful proposer(s) subsequent to the Commissioners' Court award of contract, and shall be returned to the successful proposer upon the completion and submission of all contract documents. Provided however, that the Cashier's Check or Proposer Bond will be forfeited to the County as liquidated damages should successful proposer fail to execute the contract within thirty (30) days after receiving notice of the acceptance of its proposal.

37. PERFORMANCE AND PAYMENT BONDS:

Successful proposer, before beginning work, shall execute a performance bond and a payment bond, each of which must be in the amount of the contract. The required payment and performance bonds must each be executed by a corporate surety in accordance with Section 1, Chapter 87, Acts of the 56th Legislature, Regular Session, 1959 (Article 7.19-1, Vernon's Texas Insurance Code).

The performance and payment bonds must clearly and prominently display on the bond or on an attachment to the bond:

- A. The name, mailing address, physical address, and telephone number, including the area code, of the surety company to which any notice of claim should be sent; or

GENERAL PROVISIONS
Crystal Beach Fueling Station
GALVESTON COUNTY, TEXAS

- B. The toll-free telephone number maintained by the Texas Department of Insurance under Subchapter B, Chapter 521, Insurance Code, and a statement that the address of the surety company to which any notice of claim should be sent may be obtained from the Texas Department of Insurance by calling the toll free-telephone number.

The performance bond shall be solely for the protection of Galveston County, in the full amount of the contract, and conditioned on the faithful performance of the work in accordance with the plans, specifications, and contract documents. The payment bond is solely for the protection and use of payment bond beneficiaries who have a direct contractual relationship with the prime contractor or a subcontractor to supply public work labor or material, and in the amount of the contract.

The payment and performance bonds required to be furnished herein must be furnished before the contractor begins work and are a requirement for issuance of a Notice to Proceed. Such bonds must be furnished to the Galveston County Purchasing Agent within thirty (30) days after the date of signing of the contract or receiving notice from the Purchasing Agent that the contract has been fully executed. Failure to provide the required payment and performance bonds within the required business days shall constitute an event of default under this contract. Contractor shall not commence work until all applicable certificates of insurance, performance, and payment bonds have been received and approved by the County Purchasing Agent and the Contractor receives notice to proceed in writing that has been issued by the County Purchasing Agent.

Additionally, if this request for proposal is for the award of a public works contract, then compliance with Chapter 2253 of the Texas Government Code, which is known as the McGregor Act, is mandatory. Performance and payment bonds are required to be furnished in accordance with Chapter 2253 of the Texas Government Code. Proposer should familiarize itself with the entire provisions of Chapter 2253 of the Texas Government Code.

38. PATENT AND COPYRIGHT PROTECTION:

The Proposer agrees at its sole expense to protect the County from claims involving infringement of patents or copyrights. **Proposer shall indemnify and save harmless the County of Galveston, its officers, employees, and agents, from liability of any nature and kind whatsoever, including without limitation cost and expenses, for or on account of any copyrighted, patented or un-patented invention, process, or article manufactured or used in the performance of the contract, including its use by the County.** Proposer also agrees that if Proposer is awarded this contract, that no work performed hereunder shall be subject to patent, copyright, or other intellectual property by Proposer.

39. CONFLICT OF INTEREST DISCLOSURE REPORTING:

Proposer may be required under Chapter 176 of the Texas Local Government Code to complete and file a conflict of interest questionnaire (CIQ Form). If so, the completed CIQ Form must be filed with the County Clerk of Galveston County, Texas.

If Proposer has an employment or other business relationship with an officer of Galveston County or with a family member of an officer of Galveston County that results in the officer or family member of the officer receiving taxable income that exceeds \$2,500.00 during the preceding 12-month period, then Proposer **MUST** complete a CIQ Form and file the original of the CIQ Form with the County Clerk of Galveston County.

If Proposer has given an officer of Galveston County or a family member of an officer of Galveston County one or more gifts with an aggregate value of more than \$250.00 during the preceding 12-months, then Proposer **MUST** complete a CIQ Form and file the original of the CIQ Form with the County Clerk of Galveston County.

**GENERAL PROVISIONS
Crystal Beach Fueling Station
GALVESTON COUNTY, TEXAS**

The Galveston County Clerk has offices at the following locations:

Galveston County Clerk

Galveston County Justice Center, Suite 2001
600 59th Street
Galveston, Texas 77551

Galveston County Clerk

North County Annex, 1st Floor
174 Calder Road
League City, Texas 77573

Again, if Proposer is required to file a CIQ Form, the original completed form is filed with the Galveston County Clerk (not the Purchasing Agent).

For Proposer's convenience, a blank CIQ Form is enclosed with this proposal. Blank CIQ Forms may also be obtained by visiting the Galveston County Clerk's website and/or the Purchasing Agent's website – both of these websites are linked from the Galveston County homepage, at <http://www.co.galveston.tx.us>.

As well, blank CIQ Forms may be obtained by visiting the Texas Ethics Commission website, specifically at http://www.ethics.state.tx.us/whatsnew/conflict_forms.htm.

Chapter 176 specifies deadlines for the filing of CIQ Forms (both initial filings and updated filings).

It is Proposer's sole responsibility to file a true and complete CIQ Form with the Galveston County Clerk if Proposer is required to file by the requirements of Chapter 176 of the Local Government Code. Proposer is advised that it is an offense to fail to comply with the disclosure reporting requirements dictated under Chapter 176 of the Texas Local Government Code.

If you have questions about compliance with Chapter 176, please consult your own legal counsel. Compliance is the individual responsibility of each person, business, and agent who is subject to Chapter 176 of the Texas Local Government Code.

40. COMPETITIVENESS AND INTEGRITY:

To prevent biased evaluations and to preserve the competitiveness and integrity of such acquisition efforts, **proposers are to direct all communications regarding this proposal to the Galveston County Purchasing Agent**, unless otherwise specifically noted.

Do not contact the requesting department. Attempts by offering firms to circumvent this requirement will be viewed negatively and may result in rejection of the offer of the firm found to be in non-compliance.

All questions regarding this Request for Proposal must be submitted in writing to:

Rufus Crowder, CPPO CPPB, Purchasing Agent
722 Moody, (21st Street)
Fifth (5th) Floor, Purchasing
Galveston, Texas 77550
Fax: (409) 621-7997
E-mail: rufus.crowder@co.galveston.tx.us

GENERAL PROVISIONS
Crystal Beach Fueling Station
GALVESTON COUNTY, TEXAS

An authorized person from the submitting firm must sign all proposals. This signature acknowledges that the proposer has read the proposal documents thoroughly before submitting a proposal and will fulfill the obligations in accordance to the terms, conditions, and specifications.

Please carefully review this Request for Proposal. It provides specific information necessary to aid participating firms in formulating a thorough response.

41. ENTIRETY OF AGREEMENT AND MODIFICATION:

This contract contains the entire agreement between the parties. Any prior agreement, promise, negotiation or representation not expressly set forth in this contract has no force or effect. Any subsequent modification to this contract must be in writing, signed by both parties. An official representative, employee, or agent of the County does not have the authority to modify or amend this contract except pursuant to specific authority to do so granted by the Galveston County Commissioners' Court.

42. NON-COLLUSION AFFIDAVIT:

Proposer certifies, by signing and submitting a proposal, that the proposal is not made in the interest of, or on behalf of, any undisclosed person, partnership, company, association, organization, or corporation; that the proposal is genuine and not collusive or sham; that the contractor has not directly or indirectly induced or solicited another contractor to put in a false or sham proposal, and has not directly or indirectly colluded, conspired, connived, or agreed with any contractor or anyone else to put in a sham proposal or that anyone shall refrain from bidding; that the contractor has not in any manner, directly or indirectly, sought by agreement, communications, or conference with anyone to fix the proposal price of the contractor of any other bidder, or to fix any overhead, profit or cost element of the proposal price, or that of any other contractor, or to secure any advantage against the public body awarding the contract or anyone interested in the proposed contract; that all statements contained in the proposal are true; and further, that the contractor has not, directly or indirectly, submitted his or her proposal price or any breakdown thereof, or the contents thereof, or divulged information or data relative thereto, or paid, and will not pay, any fee to any cooperation, partnership, company association, organization, proposal depository, or to any member or agent thereof to effectuate a collusive or sham proposal.

A blank Non-Collusion Affidavit is included with this proposal packet. Proposer must enclose a truthful and fully executed original Non-Collusion Affidavit with the submission of its proposal. This is a mandatory requirement of this RFP. Failure to include the truthfully and fully executed Non-Collusion Affidavit in the submission of its proposal shall be considered non-compliance with the requirements of this RFP by the Proposer and grounds for the rejection of Proposer's submission.

No negotiations, decisions, or actions shall be initiated by any company as a result of any verbal discussion with any County employee prior to the opening of responses to this Request for Proposal.

No officer or employee of the County of Galveston, and no other public or elected official, or employee, who may exercise any function or responsibilities in the review or approval of this undertaking shall have any personal or financial interest, direct or indirect, in any contract or negotiation process thereof. The above compliance request will be part of all County of Galveston contracts for this service.

43. SOVEREIGN IMMUNITY:

The County specifically reserves any claim it may have to sovereign, qualified, or official immunity as a defense to any action arising in conjunction with this contract.

44. CONTROLLING LAW AND VENUE:

GENERAL PROVISIONS
Crystal Beach Fueling Station
GALVESTON COUNTY, TEXAS

Proposer acknowledges and agrees that the contract is and shall be governed and construed by the laws of the State of Texas and that venue shall lie exclusively in Galveston County, Texas.

45. MERGERS, ACQUISITIONS:

The Proposer shall be required to notify the County of any potential for merger or acquisition of which there is knowledge at the time that a proposal is submitted.

If subsequent to the award of any contract resulting from this RFP the Proposer shall merge or be acquired by another firm, the following documents must be submitted to the County:

- A. Corporate resolutions prepared by the awarded Proposer and the new entity ratifying acceptance of the original contract, terms, conditions and prices;
- B. New Proposer's Federal Identification Number (FEIN) and;
- C. New Proposer's proposed operating plans.

Moreover, Proposer is required to provide the County with notice of any anticipated merger or acquisition as soon as Proposer has actual knowledge of the anticipated merger or acquisition. The New Proposer's proposed plan of operation must be submitted prior to merger to allow time for submission of such plan to the Commissioners' Court for its approval.

46. DELAYS:

The County reserves the right to delay the scheduled commencement date of the contract if it is to the advantage of the County. There shall be no additional costs attributed to these delays should any occur. Proposer agrees it will make no claims for damages, for damages for lost revenues, for damages caused by breach of contract with third parties, or any other claim by Proposer attributed to these delays, should any occur. In addition, Proposer agrees that any contract it enters into with any third party in anticipation of the commencement of the contract will contain a statement that the third party will similarly make no claim for damages based on delay of the scheduled commencement date of the contract.

47. ACCURACY OF DATA:

Information and data provided through this Request for Proposal are believed to be reasonably accurate.

48. SUBCONTRACTING/ASSIGNMENT:

Proposer shall not assign, sell, or otherwise transfer its contract in whole or in part without prior written permission of Commissioners' Court. Such consent, if granted, shall not relieve the Proposer of any of its responsibilities under this contract.

49. INDEPENDENT CONTRACTOR:

Proposer expressly acknowledges that it is an independent contractor. Nothing in this agreement is intended nor shall be construed to create an agency relationship, an employer/employee relationship, a joint venture relationship, or any other relationship allowing County to exercise control or direction over the manner or method by which Proposer or its subcontractors perform in providing the requirements stated in the Request for Proposal.

50. MONITORING PERFORMANCE:

The County shall have the unfettered right to monitor and audit the Proposer's work in every respect. In this regard, the Proposer shall provide its full cooperation and insure the cooperation of its employees, agents, assigns, and subcontractors. Further, the Proposer shall make available for inspection and/or copying when requested, original data, records, and accounts relating to the Proposer's work and performance under this contract. In the event any such material is not held by the Proposer in its original form, a true copy shall be provided.

GENERAL PROVISIONS
Crystal Beach Fueling Station
GALVESTON COUNTY, TEXAS

51. PROCUREMENT ETHICS:

Galveston County is committed to the highest ethical standards. Therefore, it is a serious breach of the public trust to subvert the public purchasing process by directing purchases to certain favored vendors, or to tamper with the competitive bidding process, whether it's done for kickbacks, friendship or any other reason. Since misuse of the purchasing power of a local government carries criminal penalties, and many such misuses are from a lack of clear guidelines about what constitutes an abuse of office, the Code of Ethics outlined below must be strictly followed.

Galveston County also requires ethical conduct from those who do business with the County.

CODE OF ETHICS – Statement of Purchasing Policy:

“Public employment is a public trust. It is the policy of Galveston County to promote and balance the objective of protecting the County’s integrity and the objective of facilitating the recruitment and retention of personnel needed by Galveston County. Such policy is implemented by prescribing essential standards of ethical conduct without creating unnecessary obstacles to entering public office.

Public employees must discharge their duties impartially so as to assure fair competitive access to governmental procurement by responsible contractors. Moreover, they should conduct themselves in such a manner as to foster public confidence in the integrity of the Galveston County procurement organization.

To achieve the purpose of this Article, it is essential that those doing business with Galveston County also observe the ethical standards prescribed here.”

General Ethical Standards:

It shall be a breach of ethics to attempt to realize personal gain through public employment with Galveston County by any conduct inconsistent with the proper discharge of the employee’s duties.

It shall be a breach of ethics to attempt to influence any public employee of Galveston County to breach the standards of ethical conduct set forth in this code.

It shall be a breach of ethics for any employee of Galveston County to participate directly or indirectly in a procurement when the employee knows that:

The employee or any member of the employee’s immediate family, has a financial interest pertaining to the procurement;

A business or organization in which the employee or any member of the employee’s immediate family, has a financial interest pertaining to the procurement; or

Any other person, business, or organization with which the employee or any member of the employee’s immediate family is negotiating or has an arrangement concerning prospective employment is involved in the procurement.

Gratuities:

It shall be a breach of ethics for any person to offer, give, or agree to give any employee or former employee of Galveston County, or for any employee or former employee of Galveston County to solicit, demand, accept or agree to accept from another person, a gratuity or an offer of employment in connection with any decision, approval, disapproval, recommendation, preparation of any part of a program requirement or a purchase request, influencing the content of any specification or procurement standard, rendering of advice, investigation, auditing, or in any other advisory capacity in any proceeding or application, request for ruling, determination, claim or controversy, or other

GENERAL PROVISIONS
Crystal Beach Fueling Station
GALVESTON COUNTY, TEXAS

particular matter, pertaining to any program requirement or a contract or subcontract, or to any solicitation or proposal therefor.

Kickbacks:

It shall be a breach of ethics for any payment, gratuity or offer of employment to be made by or on behalf of a subcontractor under a contract to the prime contractor or higher tier subcontractor or to any person associated therewith as an inducement for the award of a subcontract or order.

Contract Clause:

The prohibition against gratuities and kickbacks prescribed above shall be conspicuously set forth in every contract and solicitation by Galveston County.

Confidential Information:

It shall be a breach of ethics for any employee or former employee of Galveston County to knowingly use confidential information for actual or anticipated personal gain, or for the actual or anticipated gain of any other person.

Prohibition against Contingent Fees:

It shall be a breach of ethical standards for a person to be retained, or to retain a person, to solicit or secure a Galveston County contract upon an agreement or understanding for a commission, percentage, brokerage, or contingent fee, except for retention of bona fide employees or bona fide established commercial selling agencies for the purpose of securing business. Failure to abide by this section constitutes a breach of ethical standards.

Representation:

Proposer represents and warrants, by signing and submitting its proposal, that it has not retained anyone in violation of this section prohibiting contingent fees.

Contract Clause:

The representation prescribed above shall be conspicuously set forth in every contract and solicitation thereof.

52. SUBJECT TO APPROPRIATION OF FUNDS:

State law prohibits the obligation and expenditure of public funds beyond the fiscal year for which a budget has been approved by the Commissioners' Court. Galveston County anticipates this to be an integral part of future budgets to be approved during the periods of this contract, except for unanticipated needs or events which may prevent such payments against this contract. However, Galveston County cannot guarantee the availability of funds, and enters into this contract only to the extent such funds are made available through appropriation (allocation) by the Commissioners' Court. This contract shall not be construed as creating any debt on behalf of the County of Galveston in violation of TEX. CONST. art. XI, § 7, and it is understood that all obligations of Galveston County are subject to the availability of funds.

53. NOTICE:

All notices or other communications required or permitted under this contract shall be in writing and shall be deemed to have been duly given if delivered personally in hand, transmitted by facsimile, or mailed certified mail, return receipt requested with proper postage affixed and addressed to the appropriate party at the following address or at such other address as may have been previously given in writing to the parties (Proposer shall provide its notice information with its proposal submission). If mailed, the notice shall be deemed delivered when actually received, or if earlier, on the third day following deposit in a United States Postal Service post office or receptacle, duly certified, return receipt requested, with proper postage affixed. If delivered in person, notice shall be deemed delivered when received for by, or actually received by, the receiving Party.

GENERAL PROVISIONS
Crystal Beach Fueling Station
GALVESTON COUNTY, TEXAS

If transmitted by facsimile, notice shall be deemed delivered when receipt of such transmission is acknowledged.

To the County at:

Hon. Mark Henry,
County Judge of Galveston County
722 Moody (21st Street), Second (2nd) Floor
Galveston, Texas 77550
Fax: (409) 765-2653

With copies to:

Rufus Crowder, CPPO CPPB,
Galveston County Purchasing Agent
722 Moody (21st Street), Fifth (5th) Floor
Galveston, Texas 77550
Fax: (409) 621-7997

Robert Boemer, Director,
Galveston County Legal Department
722 Moody (21st Street), Fifth (5th) Floor
Galveston, Texas 77550
Fax: (409) 770-5560

To the Contractor at:

(Proposer to provide its contact name, address, and facsimile number for notice hereunder.)

54. NON-DISCRIMINATION:

- A. **Equal Employment Opportunity:** Proposer will not discriminate against any employee or applicant for employment because of race, color, religion, national origin, sex, disability, genetic information or veteran status. Proposer will take affirmative action to ensure that applicants are employed, and that employees are treated during employment, without regard to their race, color, religion, national origin, sex, disability, genetic information or veteran status. Such action shall include, but not be limited to, the following: employment; upgrading; demotion or transfer; recruitment or recruitment advertising; layoff or termination; rates of pay or other forms of compensation; and selection for training, including apprenticeship. Proposer agrees to post in conspicuous places, available to employees and applicants for employment, notices of employment.

Proposer will, in all solicitation or advertisements for employees placed by or on behalf of Proposer, state that all qualified applicants will receive consideration for employment without regard to race, color, religion, national origin, sex, disability, genetic information, or veteran status.

Proposer will cause the foregoing provisions to be inserted in all subcontracts for any work covered by this Agreement so that such provisions will be binding upon each subcontractor, provided that the foregoing provisions shall not apply to contracts or subcontracts for standard commercial supplies or raw materials.

Proposer will include the provisions herein in every subcontract or purchase order unless exempted.

- B. **Drug Free Work Place Act:** Proposer shall comply with all applicable requirements of the Drug-Free Workplace Act of 1988 and implementing regulations.

GENERAL PROVISIONS
Crystal Beach Fueling Station
GALVESTON COUNTY, TEXAS

- C. **Americans with Disabilities Act:** Proposer shall comply with all applicable provisions of the Americans with Disabilities Act and implementing regulations.

- D. **OSHA Regulations:** Proposer agrees to maintain and to display any applicable materials for its employees in accordance with OSHA regulations.

- E. **Compliance with Immigration Laws and Use of E-Verify:** Proposer agrees to comply with all requirements of the U.S. Immigration Reform and Control Act of 1986, as amended, and any implementing regulations thereto. Proposer further agrees to utilize the E-Verify system through the Department of Homeland Security on its employees. Proposer shall not employ unauthorized aliens, and shall not assign services to be performed to any supplier or subcontractor who are unauthorized aliens. If any personnel performing any services hereunder are discovered to be an unauthorized alien, then Proposer will immediately remove such personnel from performing services hereunder and shall replace such personnel with personnel who are not unauthorized alien(s).

- F. **State and Federal Law Compliance:** Proposer agrees to comply with all other State and Federal laws and regulations applicable to the provision of services under this contract.

55. RECORD RETENTION AND RIGHT TO AUDIT:

Proposer shall keep and maintain all records associated with this contract for a minimum of five (5) years from the close of the contract or as required by Federal or State law or regulation, whichever period is longer. If awarded this contract, Proposer shall allow the County reasonable access to the records in Proposer's possession, custody, or control that the County deems necessary to assist it in auditing the services, costs, and payments provided hereunder. If this contract involves the use of Federal or State

funds, then Proposer shall also allow reasonable access to representatives of the Office of Inspector General, the General Accounting Office, and the other Federal and/or State agencies overseeing the funds that such entities deem necessary to facilitate review by such agencies and Proposer shall maintain fiscal records and supporting documentation for all expenditures in a manner that conforms with OMB Circular A-87 (relocated to 2 C.F.R. Part 225) and this contract.

56. TITLE VI ASSURANCES/TxDOT:

The County is subject to Title VI of the Civil Rights Act of 1964 and the Federal and State laws and regulations of the United States Department of Transportation and Texas Department of Transportation (TxDOT). Pursuant to these requirements, the County must have its contractors provide required assurances on compliance with non-discrimination by itself and its subcontractors. The Title VI Assurances within this Subsection are not exhaustive – whenever any Federal, State, or Local requirement requires additional clauses, this list shall not be construed as limiting. Contractor agrees as follows:

- A. **Compliance with Regulations:** The Contractor shall comply with the Regulations relative to nondiscrimination in Federally-assisted programs of the Department of Transportation (hereinafter, DOT) Title 49, Code of Federal Regulations, Part 21, as they may be amended from time to time (hereinafter referred to as the Regulations), which are incorporated herein by reference and made a part of this contract.

- B. **Non-discrimination:** The Contractor, with regard to the work performed by it during the contract, shall not discriminate on the basis of race, color, national origin, religion, sex, age, disability or Veteran status in the selection and retention of subcontractors, including procurements of materials and leases of equipment. The Contractor shall not participate either directly or indirectly in the discrimination prohibited by Section 21.5 of the Regulations, including employment practices when the contract covers a program set forth in Appendix B of the Regulations.

GENERAL PROVISIONS
Crystal Beach Fueling Station
GALVESTON COUNTY, TEXAS

- C. **Solicitations for Subcontractors, Including Procurement of Materials and Equipment:** In all solicitations either by competitive bidding or negotiation made by the Contractor for work to be performed under a subcontract, including procurement of materials or leases of equipment, each potential subcontractor or supplier shall be notified by the Contractor of the Contractor's obligations under this contract and the Regulations relative to nondiscrimination on the grounds of race, color, national origin, religion, sex, age, disability or Veteran status.
- D. **Information and Reports:** The Contractor shall provide all information and reports required by the Regulations or directives issued pursuant thereto, and shall permit access to its books, records, accounts, other sources of information and its facilities as may be determined by the Galveston County or the Texas Department of Transportation to be pertinent to ascertain compliance with such Regulations, orders and instructions. Where any information required of the Contractor is in the exclusive possession of another who fails or refuses to furnish this information the Contractor shall so certify to Galveston County or the Texas Department of Transportation as appropriate, and shall set forth what efforts it has made to obtain the information.
- E. **Sanctions for Noncompliance:** In the event of the Contractor's noncompliance with the nondiscrimination provisions of this contract, Galveston County shall impose such contract sanctions as it or the Texas Department of Transportation may determine to be appropriate, including, but not limited to:
- 1) withholding of payments to the Contractor under the contract until the Contractor complies, and/or;
 - 2) cancellation, termination, or suspension of the contract, in whole or in part.
- F **Incorporation of Provisions.** The Contractor shall include the provisions of paragraphs (1) through (6) in every subcontract, including procurement of materials and leases of equipment, unless exempt by the Regulations, or directives issued pursuant thereto. The Contractor shall take such action with respect to any subcontract or procurement as Galveston County or the Texas Department of Transportation may direct as a means of enforcing such provisions including sanctions for non-compliance: Provided, however, that, in the event Contractor becomes involved in, or is threatened with, litigation with a subcontractor or supplier as a result of such direction, the Contractor may request Galveston County to enter into such litigation to protect the interests of Galveston County, and, in addition, the Contractor may request the United States to enter into such litigation to protect the interests of the United States.

57. CERTIFICATION REGARDING DEBARMENT, SUSPENSION, PROPOSED DEBARMENT, AND OTHER RESPONSIBILITY MATTERS:

Proposer certifies that neither it, nor any of its Principals, are presently debarred, suspended, proposed for debarment, disqualified, excluded, or in any way declared ineligible for the award of contracts by any Federal agency. Contractor agrees that it shall refund Galveston County for any payments made to Contractor while ineligible. Contractor acknowledges that Contractor's uncured failure to perform under this Agreement, if such should occur, may result in Contractor being debarred from performing additional work for the County, the GLO, the State, HUD, and other Federal and State entities. Further, Proposer has executed the Certification Regarding Debarment, Suspension, Proposed Debarment, and Other Responsibility Matters and returned the fully completed and executed original certification with the submission of its proposal. **The truthful and fully completed and executed original of the Certification Regarding Debarment, Suspension, Proposed Debarment, and Other Responsibility Matters must be included with the submission of Proposer's proposal and is a mandatory requirement of this RFP. Proposer's failure to include the fully completed and executed original of this Certification shall be considered non-compliance with the requirements of this RFP and grounds for the rejection of Proposer's proposal.**

GENERAL PROVISIONS
Crystal Beach Fueling Station
GALVESTON COUNTY, TEXAS

58. SECTION 231.006, FAMILY CODE/DELINQUENT CHILD SUPPORT:

Pursuant to Title 5, Section 231.006 of the Texas Family Code, as applicable, Proposer certifies that it, including all of its principals, is/are current in child support payments and therefore, that it is eligible to receive payments from State funds under a contract for property, materials, or services. Proposer acknowledges and agrees that if it is awarded this contract, then the ensuing agreement may be terminated and payment withheld if this certification is inaccurate. Finally, by the submission of its proposal, the Proposer certifies that it has included the names and social security numbers of each person with at least 25% ownership interest in Proposer within its response to the RFP and that all such persons are current in child support payments.

59. LABOR STANDARDS:

Proposer acknowledges that the contract to be awarded pursuant to this RFP is on a grant program funded with Federal funds. Proposer shall comply with the requirements of 29 CFR Part 5 and CFR Part 30 and shall be in conformity with Executive Order 11246, entitled "Equal Employment Opportunity", Copeland, "Anti-Kickback" Act (29 C.F.R. Part 3), the Davis-Bacon and Related Acts (29 C.F.R. Parts 1,3, and 5), the Contract Work Hours and Safety Standards Act (40 U.S.C. 3701 et seq.), and all other applicable Federal, State, and local laws and regulations pertaining to labor standards, insofar as those acts apply to the performance of this Agreement. Proposer is also responsible for ensuring that all subcontractors comply with the requirements of 29 CFR Part 5 and CFR Part 30 and shall be in conformity with Executive Order 11246, entitled "Equal Employment Opportunity", Copeland "Anti-Kickback" Act, the Davis-Bacon and Related Acts (29 CFR Parts 1, 3 and 5), the Contract Work Hours and Safety Standards Act (40 U.S.C. 3701 et seq.), and all other applicable Federal, State, and local laws and regulations pertaining to labor standards, insofar as those acts apply to the performance of this Agreement.

End of General Provision Section

The remainder of this page intentionally left blank

Galveston County Proposal #B151018

Project 09-012a

Fueling Station.....Crystal Beach Campus

Special Provisions

The Special Provisions section of this Request for Proposal solicitation and the exhibits attached herein are made a part of the entire agreement between the parties with respect to the subject matter of the Request for Proposal and Resultant Contract Agreement, and supersede the General Provisions, any prior negotiations, agreement and understandings with respect thereto.

Galveston County Proposal #B151018

Project 09-012a

Fueling Station Crystal Beach Campus

PROPOSAL FORM

1. OWNER: Galveston County

2. PROJECT:
Fueling Station **Crystal Beach Campus**

3. SUBMITTED BY:

Proposer Name

Proposer Address

Proposer Phone Number

Proposer e-mail or website

4. PROPOSAL:

This proposal is for design-build services of the fueling system at the new Crystal Beach Road and Bridge Facility on Bolívar Peninsula. It includes a Licensed Engineering Firm with the State of Texas and a Licensed UST Contactor with the TCEQ to provide both engineering services and a fueling system installation compliant with all Federal, State and Local regulations.

This is a turnkey project. It includes all permits and operational training for a fully operating fueling station before it is complete and turned over to Galveston County.

The site has been prepared under a separate contract. This proposer has visited the site to become familiar with the existing conditions.

This fueling station shall be connected to other buildings on the campus (the Eddie Barr Annex and the Road and Bridge Facility) for power and tele communications. Coordination of all electric and tele communication connectivity is the responsibility of this proposal.

The proposal includes the engineering (design) and installation of the following fueling equipment and construction:

- One - ConVault 2,000 Gallon Aboveground Storage Tank for unleaded gasoline service.
- One - connection for future 3,000 Gallon aboveground storage tank for diesel service
- Two – ¾ Horsepower Submersible Pumps
- One – Fuel Management System – Fuel Force fully coordinated and integrated into the City of Galveston system (the County of Galveston uses the City of Galveston system and this station will be an extension of that program)
- Two – Product Dispensers with pulsars, all stainless steel panels, hose and nozzle assemblies, external filters and internal lighting.
- One – Automatic Tank Gauge System with inventory probes, interstice and sump leak sensors
- One – Building approximately 8 foot square to house and secure the fuel system controllers. The building is to be constructed of painted 8” split face CMU with wood framed roof and overhangs to replace the original structure but at a more flood resistant elevation.
- Double wall fiberglass underground piping and single wall welded steel aboveground piping with dispenser and transition sumps.
- All necessary Tank and Piping apparatuses

Galveston County Proposal #B151018

Project 09-012a

Fueling StationCrystal Beach Campus

- Federal, State and Local Code Compliant Fueling System Design and Installation
- Spill Prevention, Control and Countermeasure (SPCC) Plan
- All Labor, Material and Installation
- Stainless steel doors with card key access integrated with the existing County wide system of card key access.
- Fiber optic connection to the County network hub in the Eddie Barr Annex (approximately 700 lf of underground conduit and necessary length of cable- verify length in the field) - The cabling shall be OSP rated, 12 strand, 62.5 micron, multimode fiber to connect the buildings together. Another contract will provide fiber trays for each end as well as the SC patch ports. Provide a total of four (4) fiber pairs terminated by this contract.
- Fiber Optic connection to Road and Bridge Facility via existing conduit to the tele/data closet in the new Road and Bridge Facility (approximately 300 lf – verify length in the field) - The cabling shall be OSP rated, 12 strand, 62.5 micron, multimode fiber to connect the buildings together. Another contract will provide fiber trays for each end as well as the SC patch ports. Provide a total of four (4) fiber pairs terminated by this contract.
- One Year Warranty from date of acceptance
- Additional information is provided on the attached drawing sheets 1 through 4.
- Drawings from the Road and Bridge Facility project are also attached and provided for the benefit of the proposer in preparing a proposal. Actual site conditions may vary from drawings C1.0 Civil Site Plan, A0.1 Site Plan, and E0.1 Site Power Plan. A full set of Road and Bridge documents may be viewed on the County web site upon request.

- A. Having examined the drawings listed above, dated March 28, 2015 and having visited and fully inspected the site and examined all conditions affecting the Project, the undersigned, proposes to perform the various items of work listed below for the sum or sums set forth below.
- B. In submitting this proposal, the undersigned, agrees to the following:
01. Hold the proposal open for acceptance for 60 days from the submission of Proposal.
 02. Accept the right of the Owner to reject any, or all proposals, to waive formalities, and to accept the proposal which the Owner considers most advantageous to him.
 03. Accept the right of the Owner to reject any Subcontractor. A new Subcontractor may be contracted with the difference in proposal amount added to, or subtracted from, the Contract.
 04. Complete the Work within the stipulated Contract Time.
- C. Furnish insurance.
- D. The undersigned acknowledges that being notified that he has the best responsible Proposal does not convey upon him any property right to an award of the Contract or anything of value. The undersigned also acknowledges that no rights rest under the Proposal or tentative award and that any rights the Proposer may obtain will arise only upon execution of the Contract.

Galveston County Proposal #B151018

Project 09-012a

Fueling Station Crystal Beach Campus

5. Crystal Beach Fueling Station: The undersigned agrees to perform the complete Work of this Project, for the lump sum price of:

_____ Dollars and no/100 \$ _____
(Amount written in words governs) (Amount in figures)

6. OH&P FOR CHANGES IN THE WORK:

The overhead and profit applied to any change of scope of work will be set as follows:

____ % Overhead

____ % Profit

Proposers Printed Name:.....

Proposers Address:
.....

Proposers Phone Number.....

Signatory's Printed Name:.....

Signatory's Position/Title:.....

Signature:..... date.....

Note that Section 00104 - Proposal Evaluation Waiver and other documents must accompany this form.

STATE OF TEXAS TAX STATEMENT OF MATERIALS and other charges:

The cost of in-place materials to be incorporated into the project in the Base Proposal \$ _____

The cost of labor, profit, materials not in-place and all other charges in the Base Proposal \$ _____

TOTAL: (Must agree with Proposal (para. 8) total above)..... \$ _____

A copy of the Proposer's completed CIQ Form that has been filed with the Galveston County Clerk's Office must be included with Proposer's Proposal.

A copy of Section 00104 Proposal Evaluation Waiver must be included with Proposer's Proposal.

Galveston County Proposal #B151018

Project 09-012a

Fueling Station Crystal Beach Campus

SECTION 00104 PROPOSAL EVALUATION WAIVER AND QUALIFICATION STATEMENT

By submitting a proposal, the Proposer indicated below agrees to waive any claim it has or may have against the Owner arising out of or in connection with the administration, evaluation, or recommendation of any proposal. The Proposer further agrees the Owner reserves the right to waive any requirements under the proposal documents or the Contract Documents, acceptance or rejection of any proposals, and recommendation or award of the contract.

In order to evaluate proposals the following items **must** be turned in along with the proposal form to allow Galveston County to determine the best overall proposal.

The information below shall be provided on the Proposer's letterhead. Failure to provide the information may result in no points awarded for that item in the evaluation process. Each item below will be researched for each Contractor and assigned a relative value more fully described on the Proposal Tabulation Form attached for information only in Section 00300.

- a) References from **all or the most recent 20** previous contracts comparable to this contract size and scope during the last five years. (Including complete Owner name, individual Owner contact, current phone numbers, project size, etc.). This item accounts for 10% of the evaluation scoring.
- b) References from **all or the most recent 20** previous contracts with Galveston County and other political subdivisions located within Galveston County. (Include Entity name, individual Entity contact, current phone numbers, project size, etc.). This item accounts for 5% of the evaluation scoring.
- c) Single page resume of superintendent, Project Manager, and Project Executive for this project. The quality of personnel accounts for 5% of the evaluation scoring.
- d) Listing of proposed subcontractors, suppliers, and other team members. The quality of subcontractors, suppliers, and other team members (if none then the quality of personnel above will be duplicated here) accounts for 5% of the evaluation scoring.
- e) Based upon references listed above the probability of satisfactory post construction maintenance, repair, and service for emergency warranty work. The probability of satisfactory response to warranty work accounts for 5% of the evaluation scoring.
- f) Based upon references listed above the probability of satisfactory timely completion of the work. The probability of satisfactory timely completion of the work accounts for 5% of the evaluation scoring.
- g) The Proposer's safety record including the current EMR (experience modifier rate). The EMR relative to 1 accounts for 5% of the evaluation scoring.
- h) The Proposer's history of claims, mediation, litigation or arbitration with any Owner in the past 5 years. This item accounts for 5% of the evaluation scoring.
- i) The Proposer's historic compliance with laws and codes governing construction activities, including any current or past (within the past year) asbestos violations with the Department of State Health Services. This item accounts for 5% of the evaluation scoring.
- j) The proposer's description of the proposed design and construction that accurately describes proposers understanding of this specific project and fueling stations. Include explanatory drawings of the design proposed. This presentation of the proposer's description accounts for 20% of the evaluation scoring.
- k) The Proposer's cost accounts for 30% of the evaluation scoring.

Galveston County Proposal #B151018

Project 09-012a

Fueling Station Crystal Beach Campus

NOTE: The Statement of Affirmation Must Be Notarized.

STATEMENT OF AFFIRMATION

“The undersigned affirms that he/she is duly authorized to execute this waiver by the person(s) or business entity making the proposal.

Proposer’s Name:.....

Proposers Address:

.....

.....

Signatory's Name:

Signatory's Position/Title:

Signature:..... date.....

Subscribed and sworn to me on this _____ day of _____

Notary Public

My Commission expires _____

NOTE: THIS FORM MUST BE EXECUTED AND SUBMITTED WITH PROPOSAL.

END OF SECTION

Galveston County Road and Bridge Dept. Crystal Beach Facility

RFP Design Build Contract for Crystal Beach Fueling Station

Evaluation Team Member -x

Grading:	30	20	10	5	5	5	5	5	5	5	5	5	5	5	5	100	
Budget Not Provided	Proposal Bond	Proposal Information	Site Visit														
	Base Proposal	Quality of proposed design and construction description	References from previous contracts comparable in size and scope	Quality of performance with County (or other political subdivisions in County) on previous contracts	Quality of Proposed personnel	Quality of Proposed subcontractor, supplier, or team members personnel	Probability of satisfactory future maintenance, repair, & service, including time for emergency warranty work	Compliance with laws on previous contracts	Proposer performance record of timely completion on previous projects similar in size and scope	Proposer safety record including current EMR	Proposer history of claims, litigation, or arbitration with any Owner in the last 5 years					Total Score	
Lowest Base proposal and selected alternates (if any)																	
\$1																	
Proposer																	
	Cost	\$1	100	100	100	100	100	100	100	100	1.00	100					
	Grading Score	30.00	20.00	10.00	5.00	5.00	5.00	5.00	5.00	5.00	5.00	5.00	5.00	5.00	5.00	5.00	100.00
	Rating	\$1	100	100	100	100	100	100	100	100	1.00	100					
	Grading Score	30.00	20.00	10.00	5.00	5.00	5.00	5.00	5.00	5.00	5.00	5.00	5.00	5.00	5.00	5.00	100.00
	Cost	\$1	100	100	100	100	100	100	100	100	1.00	100					
	Grading Score	30.00	20.00	10.00	5.00	5.00	5.00	5.00	5.00	5.00	5.00	5.00	5.00	5.00	5.00	5.00	100.00
	Rating	\$1	100	100	100	100	100	100	100	100	1.00	100					
	Grading Score	30.00	20.00	10.00	5.00	5.00	5.00	5.00	5.00	5.00	5.00	5.00	5.00	5.00	5.00	5.00	100.00
	Cost	\$1	100	100	100	100	100	100	100	100	1.00	100					
	Grading Score	30.00	20.00	10.00	5.00	5.00	5.00	5.00	5.00	5.00	5.00	5.00	5.00	5.00	5.00	5.00	100.00
	Rating	\$1	100	100	100	100	100	100	100	100	1.00	100					
	Grading Score	30.00	20.00	10.00	5.00	5.00	5.00	5.00	5.00	5.00	5.00	5.00	5.00	5.00	5.00	5.00	100.00

The Safety record will be scored based upon all EMR below 1 being awarded 5 points, an EMR of 1 awarded 4 points, an EMR of 1.1 awarded 3 points, an EMR of 1.2 awarded 2 points, an EMR of 1.3 awarded 1 point.

No team is perfect.	100	Perfect
What we want	90	Quality Work and willingly contributes to the team effort
if above not available	80	Quality work and causes the rest of the team extra effort to deal with them.
Acceptable	70	Good work and willingly advances the team effort
Mediocre	60	Good work and causes the rest of the team extra effort to deal with them.
Only if we have to	50	Marginally acceptable work and willingly contributes to the team effort
Prefer not	40	Marginally acceptable work and causes the rest of the team extra effort to deal with them.
No	30	Poor work and attempts to contribute to the team effort
This will just waste time	20	Poor work and causes the rest of the team extra effort to deal with them.
please don't submit	0	

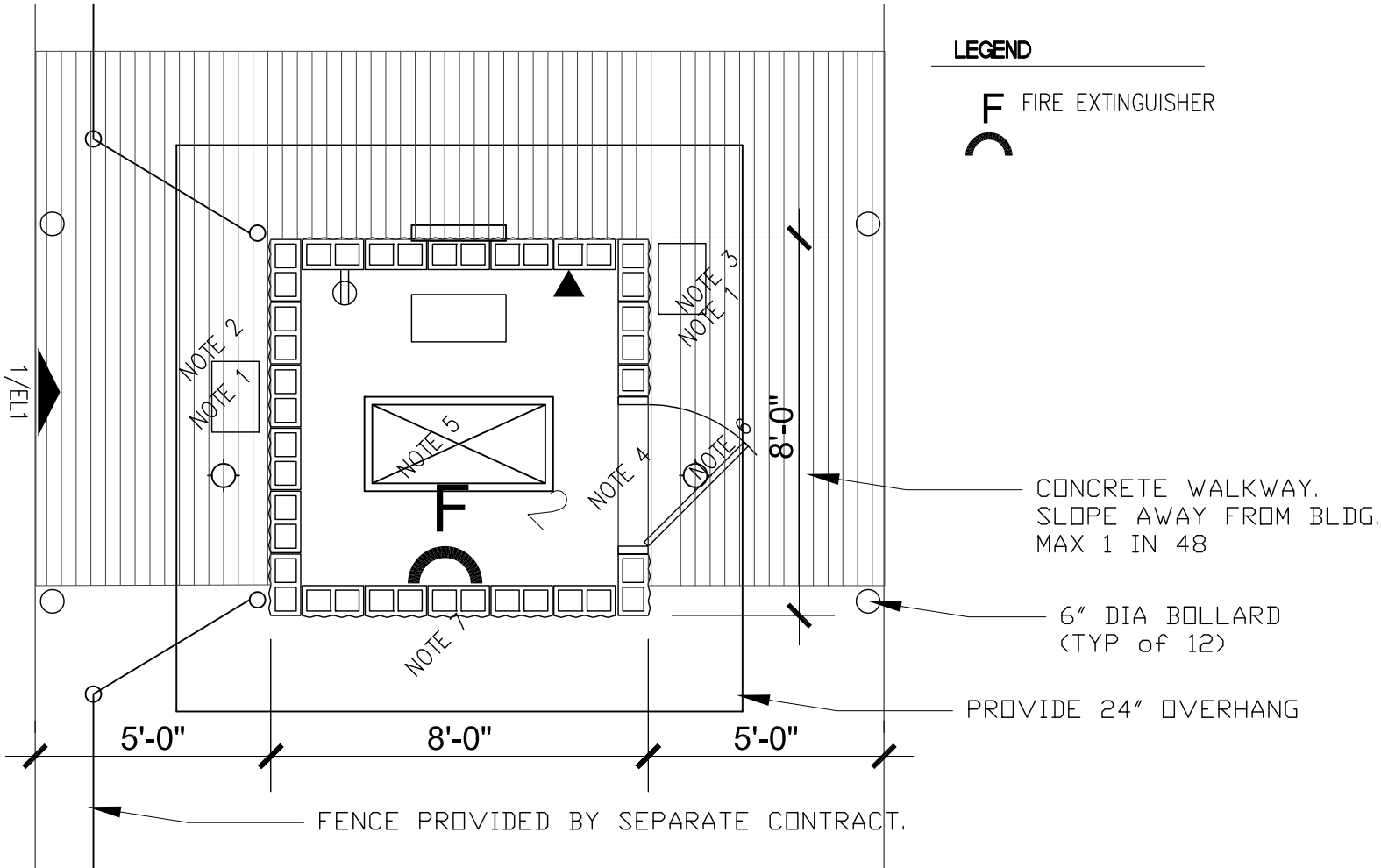

1 Floor Plan

1/4" = 1'-0"

PROJECT IS TO PROVIDE A NEW FUELING STATION AT THE CRYSTAL BEACH ROAD AND BRIDGE FACILITY.

THE PLAN ABOVE LOCATES EQUIPMENT AND THE SIZE OF THE BUILDING. DESIGN OF THE BUILDING AND EQUIPMENT IS THE RESPONSIBILITY OF THE CONTRACT.

ALL EXPOSED METAL SHALL BE 316 STAINLESS STEEL.

ROOF MAY BE ASPHALT COMPOSITION SHINGLES.

FUEL TANKS MUST BE SECURELY ANCHORED TO RESIST WIND AND WATER LOADS IMPOSED BY POTENTIAL STORM ACTIVITY.

NOTES

NOTE 2

1. FUEL FORCE 894-K FUEL KEY CONTROLLER. REQUIRES PROXIMITY CARD ACCESS TO REQUEST FUEL.
2. UNLEADED GASOLINE FUEL DISPENSER.
3. DIESEL FUEL DISPENSER.
4. 3070 SS(316) DOOR AND FRAME - FULL LOUVER, CONTINUOUS HINGE, CLOSER, AND HARDWARE (BEST CORE)..
5. 2X4 CEILING MOUNT LED FIXTURE OPERATES 24/7 SUITABLE FOR DAMP LOCATIONS
6. SURFACE MOUNTED LED SOFFIT LIGHT SUITABLE FOR DAMP LOCATIONS OPERATES 24/7.
7. 8" SPLIT FACE CMU

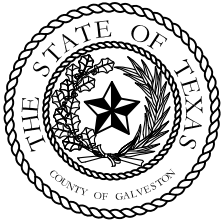

FUELING STATION

CRYSTAL BEACH ROAD AND BRIDGE FACILITY

CRYSTAL BEACH

1

MARCH 28, 2015

page 1 of 4

PROJECT NO. 09-012a

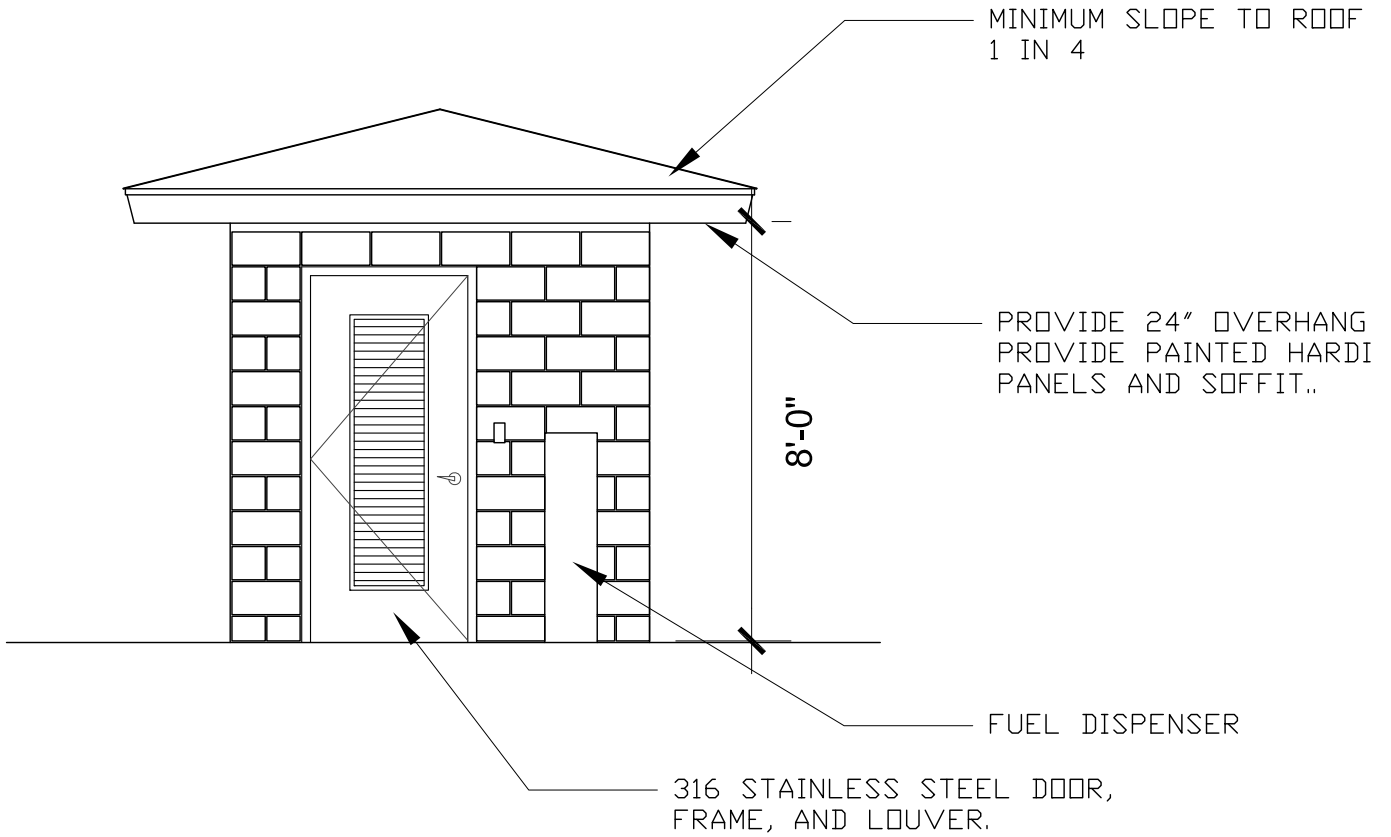

1

ELEVATION

1/4" = 1'-0"

NOTES

1. ROOFING MAY BE WINDSTORM RESISTANT ASPHALT COMPOSITION SHINGLES.

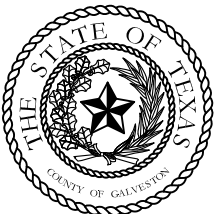

**FUELING STATION
CRYSTAL BEACH ROAD AND BRIDGE FACILITY
CRYSTAL BEACH**

2
MARCH 28, 2015
page 2 of 4

PROJECT NO. 09-012a

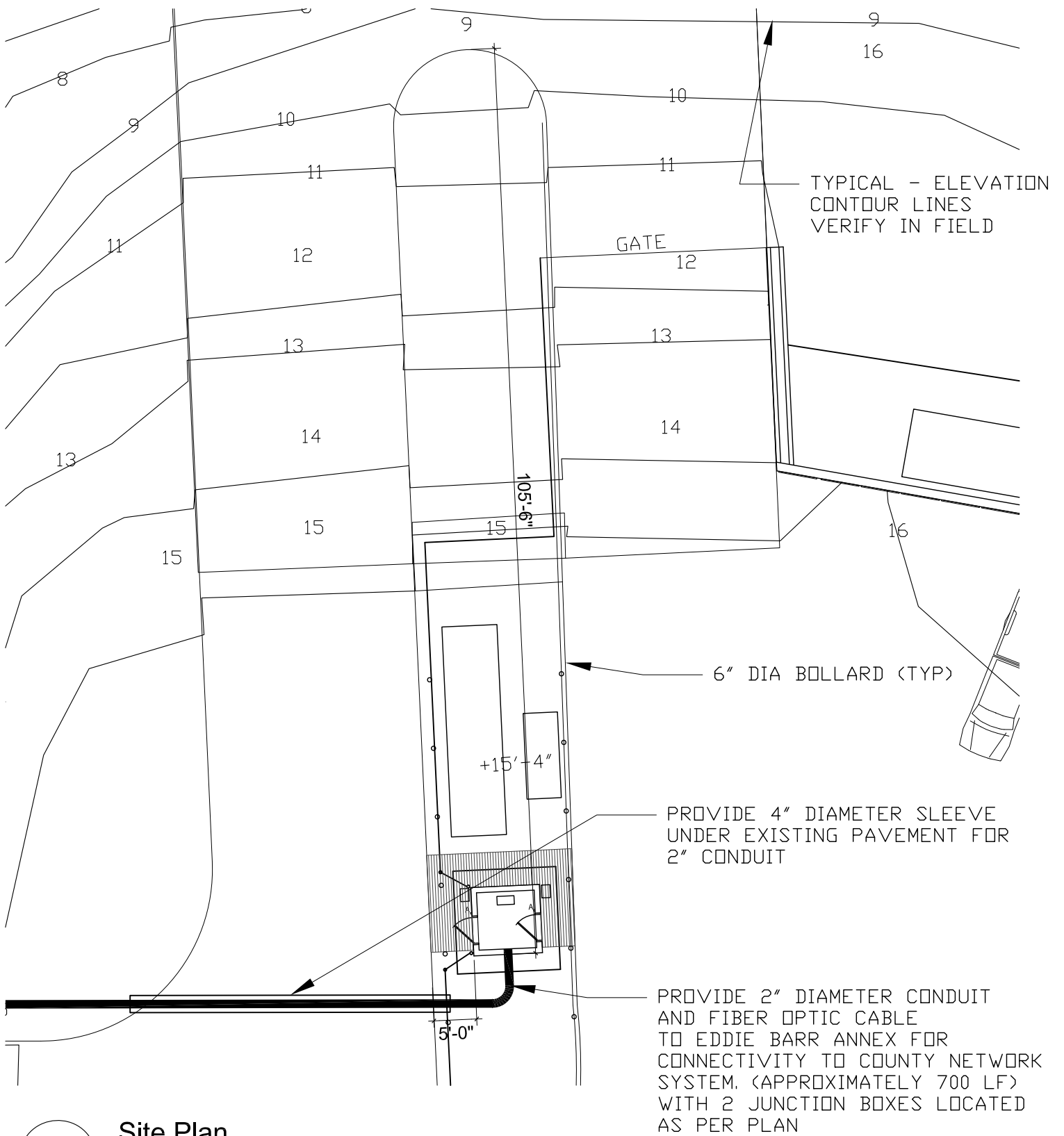

1

Site Plan

1:100

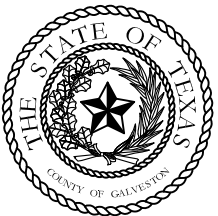

**FUELING STATION
CRYSTAL BEACH ROAD AND BRIDGE FACILITY
CRYSTAL BEACH**

3

MARCH 28, 2015

page 3 of 4

PROJECT NO. 09-012a

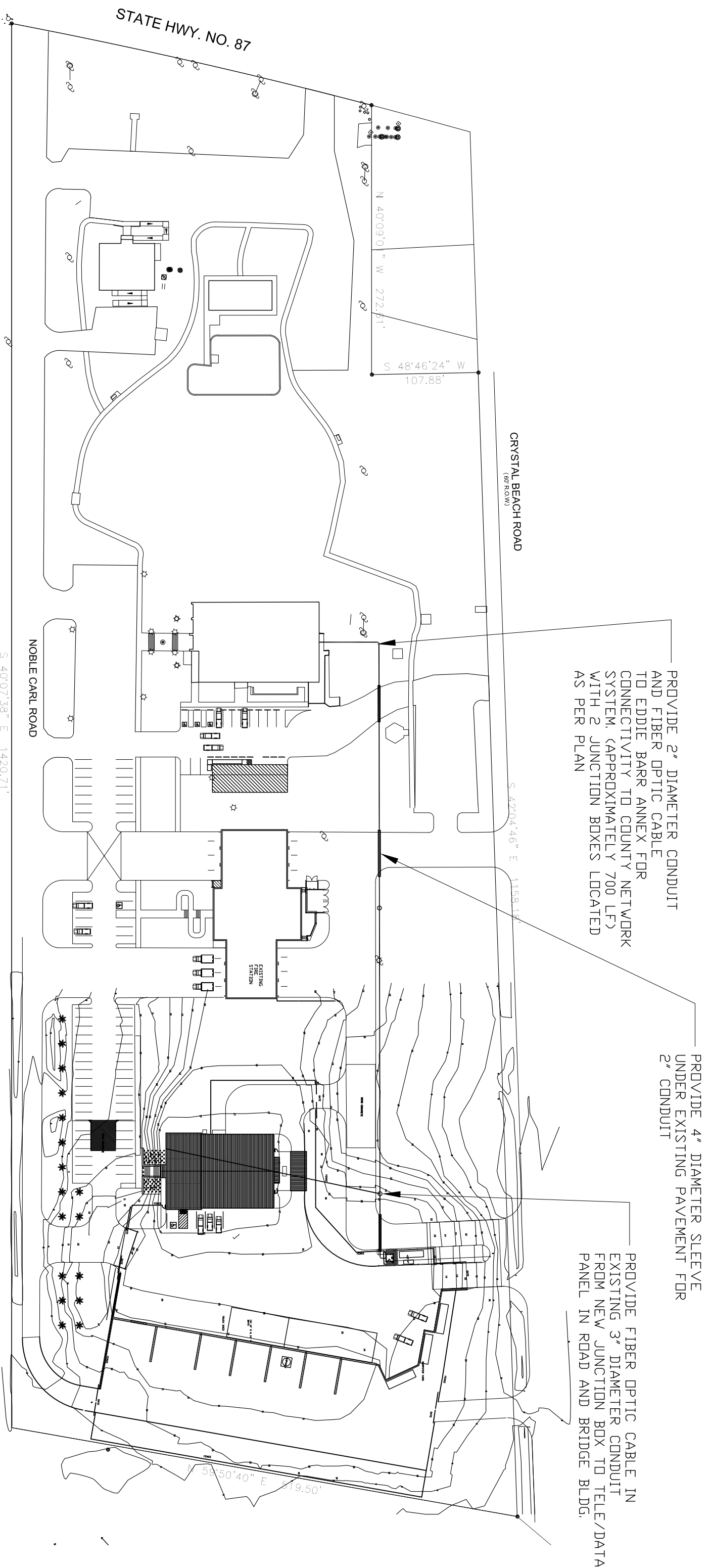

PROVIDE 2" DIAMETER CONDUIT AND FIBER OPTIC CABLE TO EDDIE BARR ANNEX FOR CONNECTIVITY TO COUNTY NETWORK SYSTEM. (APPROXIMATELY 700 LF) WITH 2 JUNCTION BOXES LOCATED AS PER PLAN

PROVIDE 4" DIAMETER SLEEVE UNDER EXISTING PAVEMENT FOR 2" CONDUIT

PROVIDE FIBER OPTIC CABLE IN EXISTING 3" DIAMETER CONDUIT FROM NEW JUNCTION BOX TO TELE/DATA PANEL IN ROAD AND BRIDGE BLDG.

S 40°07'38" E 1420.71'

S 42°04'46" E 1158.12'

N 40°09'0" W 272.61'

S 48°46'24" W 107.88'

N 59°50'40" E 219.50'

1 Site Plan
1:1200

FUELLING STATION
CRYSTAL BEACH ROAD AND BRIDGE FACILITY
CRYSTAL BEACH

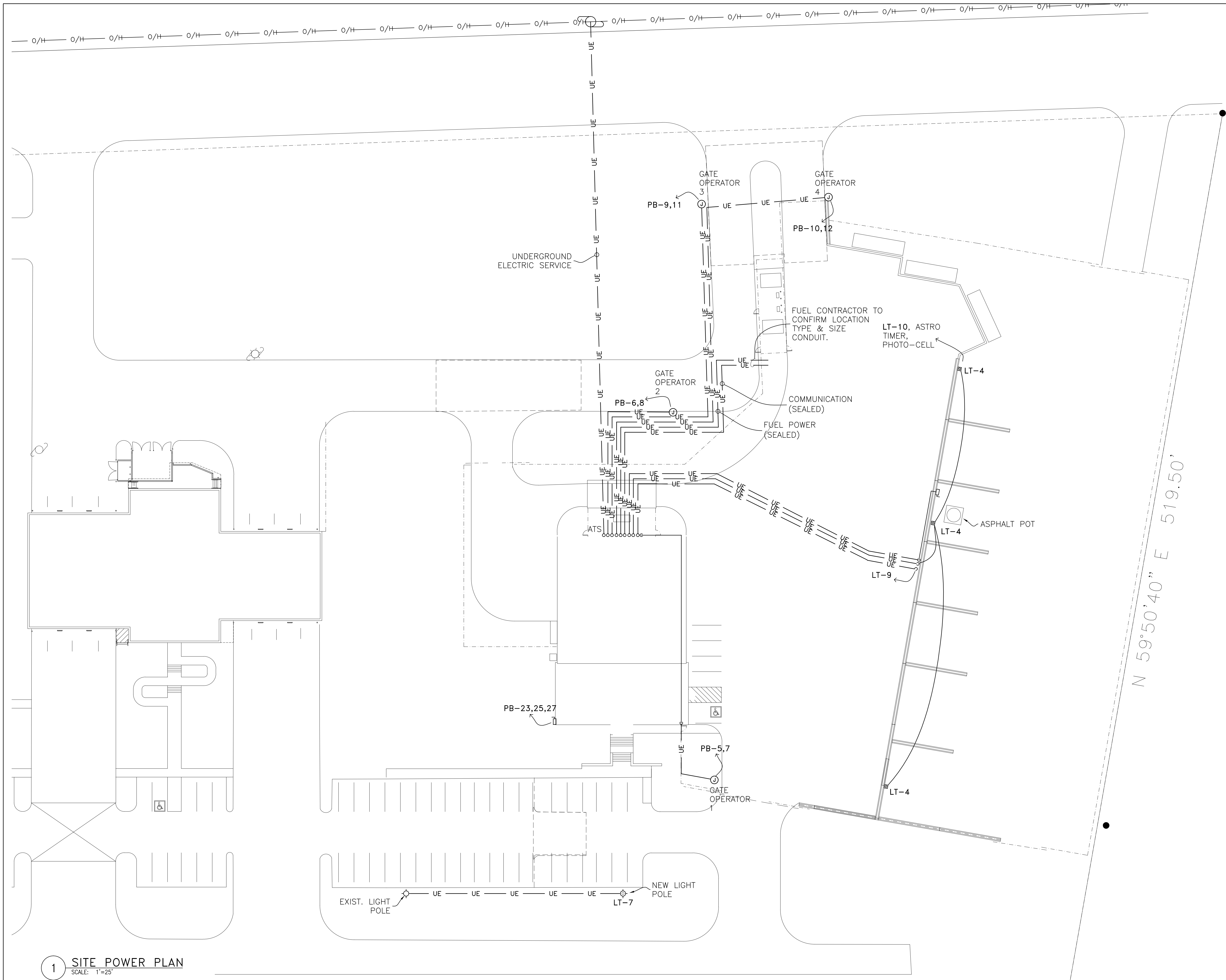

1 SITE POWER PLAN
SCALE: 1"=25'

COUNTY ROAD AND BRIDGE
CRYSTAL BEACH FACILITY
BOLIVAR, TEXAS
BE-Arc LLC Project No : C-13-007.01



IBIS ENGINEERING
PO Box 55171
Galveston, Texas 77555
Phone (409) 539 - 5548

CONSULTANT SEAL

DATE	REVISION
5/19/14	FOR BIDDING

FOR BIDDING

DATE ISSUED:
5/19/2014
COPYRIGHT 2013



The seal appearing on this document was authorized by
JANET MURRAY HOFFMAN
P.E. 102117
5/19/2014

EO.1

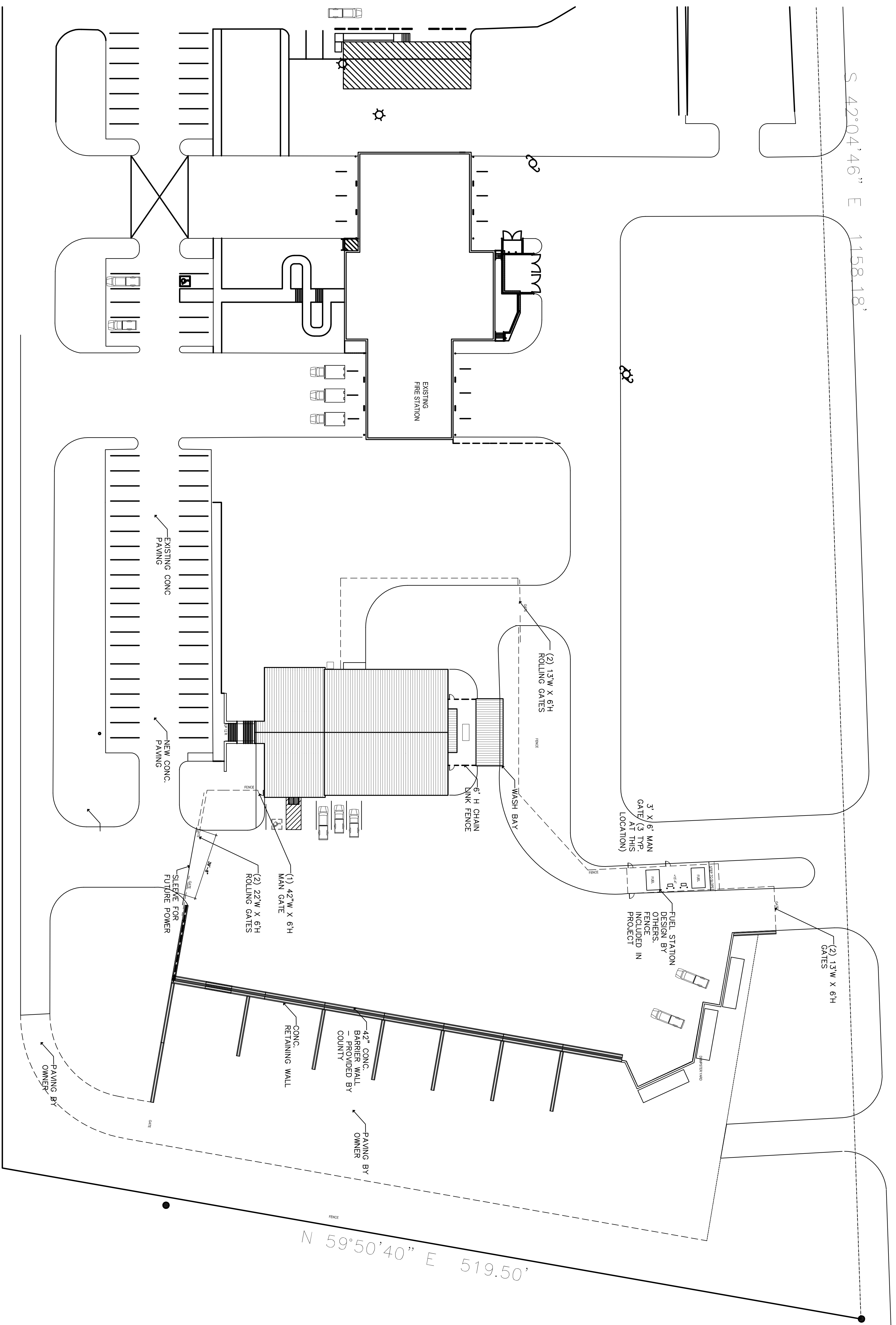

**COUNTY ROAD AND BRIDGE
CRYSTAL BEACH FACILITY
BOLIVAR, TEXAS**

BE-Arc LLC Project No : C-13-007.01

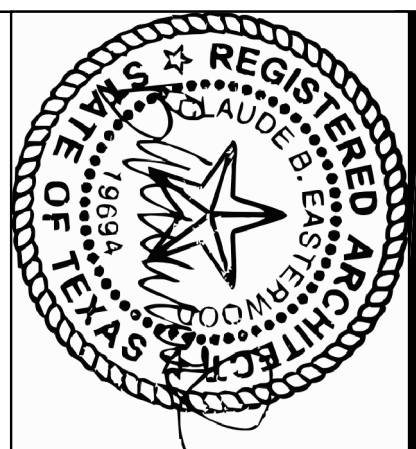

**BRAX EASTERWOOD
DESIGN**

2728 AVENUE Q SUITE 2
GALVESTON TEXAS 77550
PHONE 409-354-8976
EASTERWOOD@BEAIA.COM

CONSULTANT SEAL	
DATE	REVISION

ISSUED FOR PROPOSALS

DATE ISSUED:
5/19/2014
COPYRIGHT 2014

A0.1

SITE PLAN

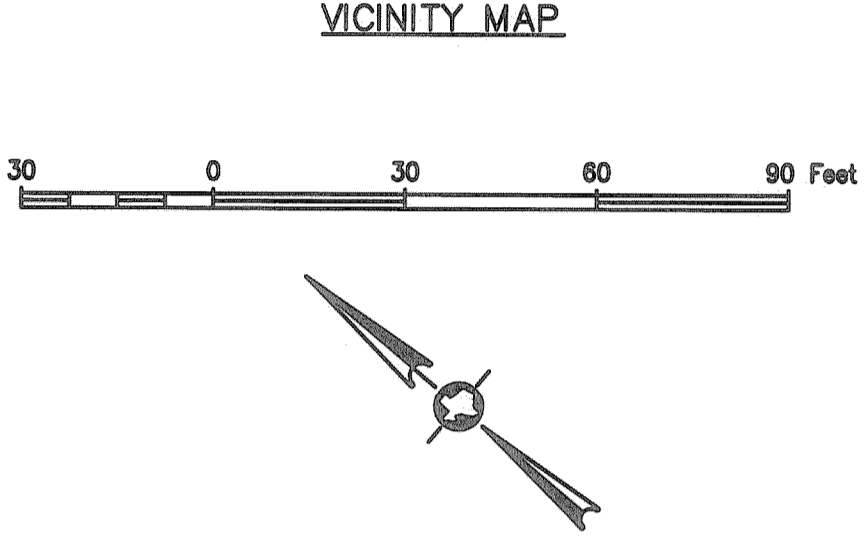
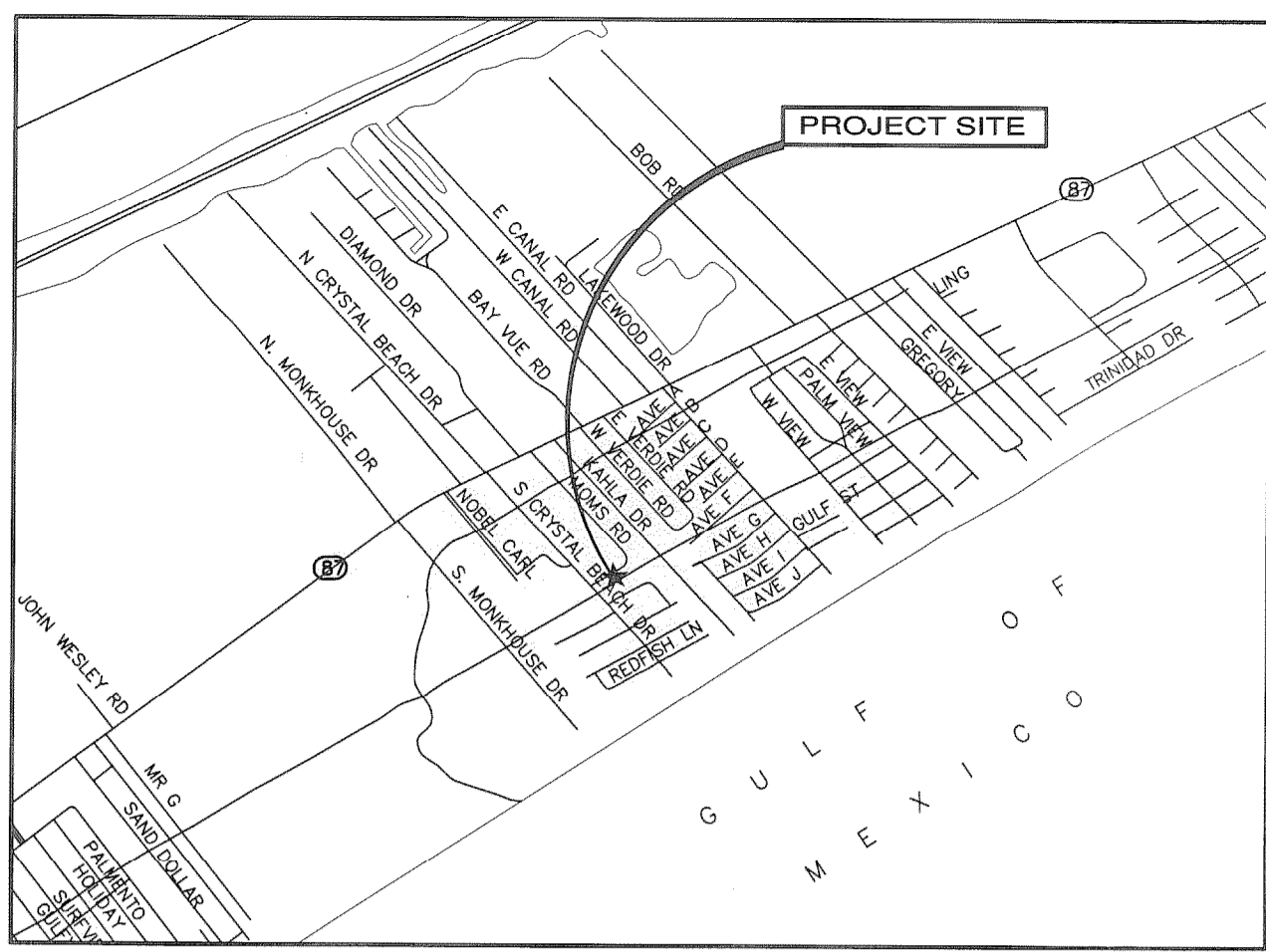
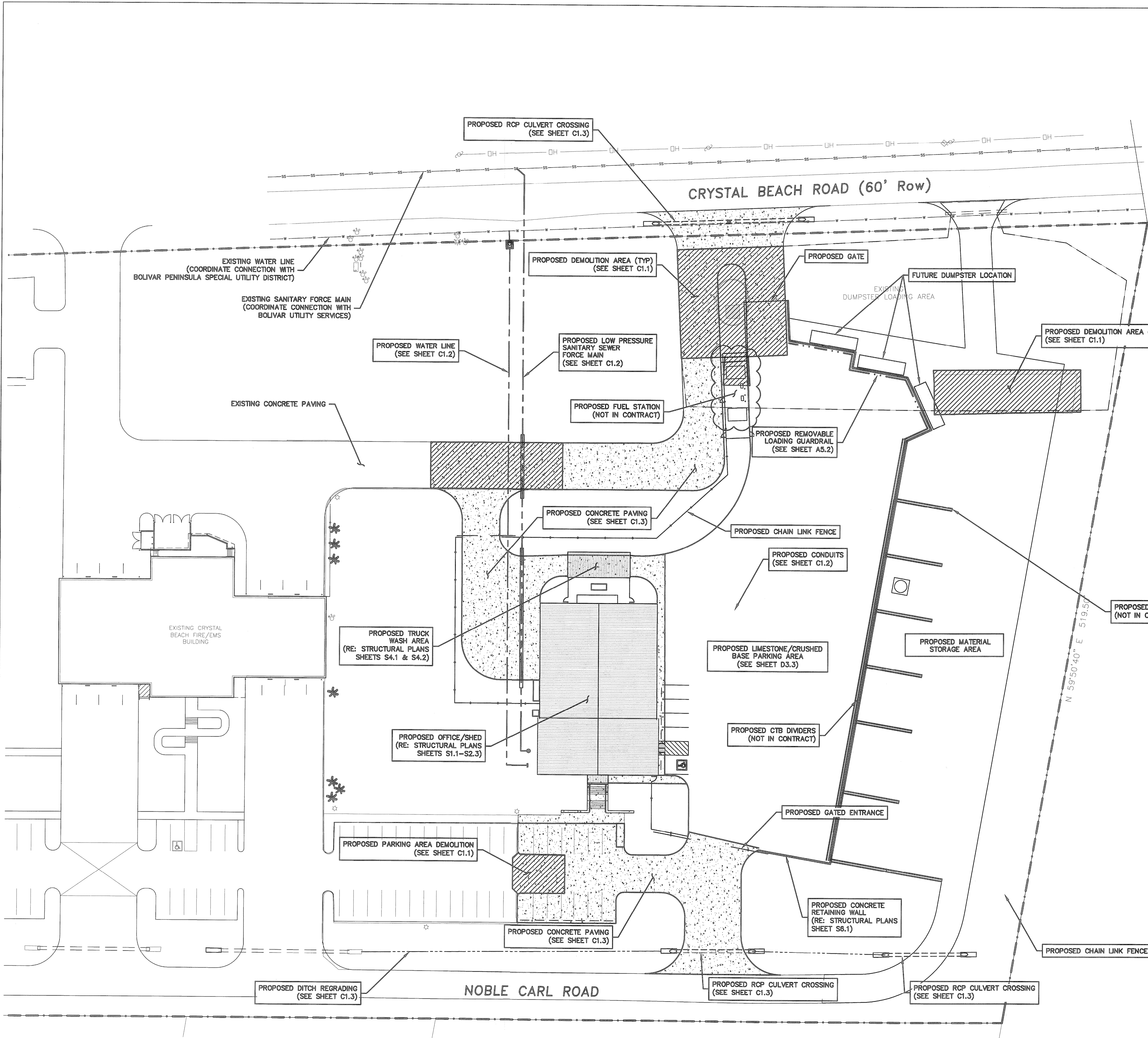

THE AREA OF THIS SURVEY IS IN FIRM 485470 0124E MAP REVISED JULY 5, 1993, ZONE A15 BFE 15.

- SURVEYOR NOTES:**
- 1) THIS PROPERTY DOES LIE WITHIN THE 100 YEAR FLOOD PLAIN AS ESTABLISHED BY THE FEDERAL EMERGENCY MANAGEMENT AGENCY.
 - 2) THIS PROPERTY IS SUBJECT TO ANY RESTRICTIONS OF RECORD AND MAY BE SUBJECT TO SETBACKS FROM POWER LINES AS ESTABLISHED BY OSHA (CALL YOUR POWER COMPANY).
 - 3) GRID BEARINGS BASED ON MONUMENTATION OF WEST R.O.W. LINE OF NOBLE CARL DRIVE.
 - 4) ELEVATIONS ARE SHOWN IN FEET ABOVE MEAN SEA LEVEL NAVD '88 DATUM AS TIED TO NGS MONUMENT HCCSD 64.
 - 5) SURVEYED WITHOUT BENEFIT OF A TITLE REPORT.

**COUNTY ROAD AND BRIDGE
CRYSTAL BEACH FACILITY
BOLIVAR, TEXAS**

BE-Arc LLC Project No : C-13-007.01

SHELMARK ENGINEERING, L.L.C.
CIVIL | MARINE | PLANNING | STRUCTURAL

921 FM 517 Road East | Dickinson, Texas 77539
Tel: 409.742.2115

SME NO. 12-324



DATE	REVISION

ISSUED FOR PROPOSALS

DATE ISSUED:
5/19/14

COPYRIGHT 2013

C1.0



894-K FUEL KEY CONTROLLER

Take control of your fuel operations with the economical FuelForce® system by Multiforce. Proximity keys or cards provide the highest level of security for your vehicles or drivers.

The FuelForce® 894-K fuel controller authorizes and controls the dispensing of products to fleet vehicles from any number of sites while collecting accurate, valuable fuel usage and vehicle data for fleet management.

FuelForce® is unmatched in ease-of-use by both vehicle operators and management personnel. FuelForce® can be implemented in stages, adding sites to gradually replace or supplement your old system.



[Anything less will cost you more.](#)

FUELFORCE® System Features

Web or Software Based – Operate your fuel management system from any computer using FuelServe.net (a secure, password protected web based application). You control vehicle & driver data and have access to your fuel transaction reports. Software options include PC, Server, interactive network and SQL Server versions.

Transaction & Billing Reports – Now you will receive transaction and billing reports that detail time, site, vehicle, odometer, driver, fuel issued and other data that you determine is relevant. The fuel management system flexibility allows you to capture a transactions at any intervals that you select from any fuel controller, or send reports or files to various departments and agencies.

Compliance – FuelForce® integrates with your tank monitoring systems to meet tight federal and state regulations. FuelForce® provides tank reconciliation on every tank in the system and provides reports necessary to assure compliance.

Security – You control all aspects of security including access to fueling sites, access to island terminals, access to sensitive data, and authorization for issuing fuel. Each of these critical areas allows you to authorize fuel in a timely and efficient manner.

FUELFORCE® Your Data At The Controller

Your existing fuel / fleet software or a spreadsheet can be used to load the necessary data. The controller then contains all data elements required to control fuel and produce reports.

FUELFORCE® 894-K Site Controller Specifications



- ◆ Rugged numeric 16 button flat faced keypad
- ◆ Four line, 80 character LCD backlit screen
- ◆ 'Add Products' button for entering oil or fluids
- ◆ Controls up to 4 hoses per controller
- ◆ Functional at -20° to 140°F
- ◆ Solid state disk storage
- ◆ Weather resistant corrosion resistant housing
- ◆ Durable proximity card & key fob reader
- ◆ 50,000 vehicles and 50,000 driver capacity
- ◆ Serial link to Tank Level Sensing equipment
- ◆ Hardwire, network & wireless communication
- ◆ Power and communication line protection
- ◆ Overhanging hood design reduces glare
- ◆ Optional control of gate or carwash devices

FUELSERVE.NET™ Fuel Management Service, Support & Reports

View your fleet fuel usage, vehicle utilization and operating cost information without the daily database administration. Obtain the benefits of on demand polling of your fuel sites, easy access to your vehicle, driver, key and site data. View and download reports when it is convenient for you.

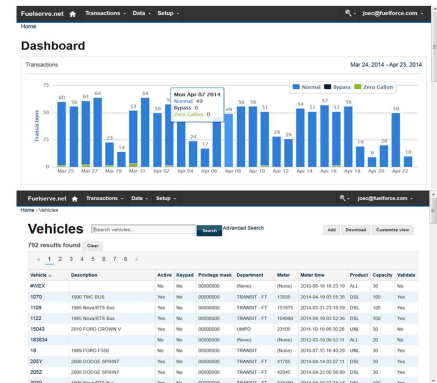

FUELFORCE® System Advantages

Convenience

- No software or training needed at your site
Obtain fuel transaction reports on-line
Transaction data when you want it
- All fuel data in a single database
Positive database at the fuel island
- 800 telephone number for Customer Service

Control

- Virtual elimination of fuel shrinkage
- Automatic odometer checking at your site
- Obtain tank reconciliation reports
- Update vehicle, driver, key & card data
with a simple user interface

Cost Savings

- Simple key system ensures accurate fuel transaction reports
- Reduces end user clerical effort
Multiforce can administer the software for you
Import/Export data capability to 3rd party software
- Identification of off-road fuel tax rebates
Optional reports that facilitate tax rebate applications
- Keypad transactions for low volume or non-key equipment
- System reliability lowers your total cost of ownership
Simple expansion and upgrade paths



PHONE: **(609) 683-4242**
FAX: **(609) 683-4835**
WWW.FUELFORCE.COM

MULTIFORCE
systems corporation

101 WALL STREET PRINCETON, NJ 08540

ConVault

Fire Protection

Seamless, six-inch reinforced concrete provides two-hour fire protection as per U. L. 2085 specification.

Versatility

ConVault can be manufactured and configured for a variety of uses in restricted spaces.

Engineered To Last

ConVault is Engineered to provide decades of rust resistant, low maintenance service.

EPA Compliant

ConVault is compliant with EPA regulations, Spill Prevention, Containment, and Countermeasures plans.

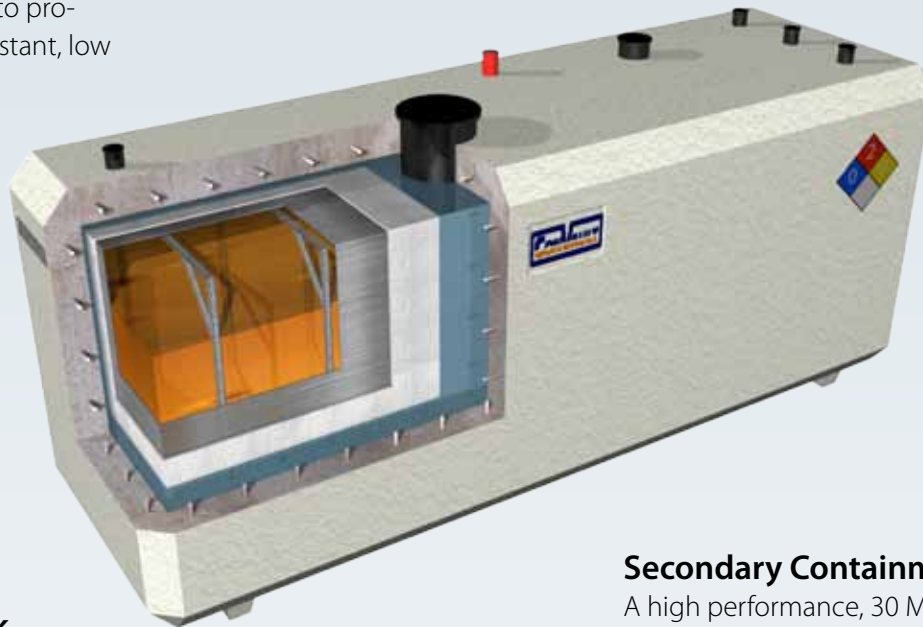

Impact Resistant

Vehicle impact, projectile, and blast resistance exceeds U. L. 2085 specification.

Multiple Size Options

ConVault provides versatile storage solutions with tank sizes ranging from 125 to 12,000 gallons.

Primary Steel Tank

The steel tank is isolated from the concrete encasement to assure corrosion protection.

Secondary Containment

A high performance, 30 MIL high density polyethylene membrane encloses the primary tank and provides secondary containment.

Thermal Protection

ConVault's monolithic concrete enclosure and insulation layers provide thermal protection.

ConVault Benefits

- **UL listed** - ConVault AST is listed in accordance with ULC 142.16, ULC 142.23 and UL Standard 2085 Insulated/Secondary Containment for Above ground Storage Tanks/Protected Type.
- **Meets Safety Regulations** - ConVault tanks meets all safety requirements for primary and secondary containment, leak monitoring, spill containment and overfill protection.
- **Manufactured** to the rigid standards of the Oldcastle quality control program at Oldcastle facilities around the country.
- **Engineering** - Every ConVault tank is designed and engineered to meet or exceed industry requirements for above ground fuel storage.
- **Environmentally Secure** - With multiple layers of containment surrounded by 6" of steel reinforced concrete, ConVault is designed to protect.
- **LEED** - Manufactured locally with recycled material.

**Crystal Beach Fueling Station
Galveston County**

Agreement between Galveston County and Contractor

Agreement for: Galveston County Crystal Beach Fueling Station

This contract is entered into between Galveston County and the Contractor named below pursuant to Sub chapter B, Chapter 271, Texas Local Government Code, and the referenced Request for Design Build Services

Contract No: CM15129

Proposal No: B151018

Contractor: _____

Galveston County Authorized Representative: J. Dudley Anderson, County Architect

Article I.

The Work

Section 1.01 The Contractor and Galveston County agree that the materials and equipment to be furnished and the work to be done by the Contractor are as follows:

This agreement is for design-build services of the fueling system at the new Crystal Beach Road and Bridge Facility on Bolívar Peninsula. It includes a Licensed Engineering Firm with the State of Texas and a Licensed UST Contactor with the TCEQ to provide both engineering services and a fueling system installation compliant with all Federal, State and Local regulations.

This is a turnkey project. It includes all permits and operational training for a fully operating fueling station before it is complete and turned over to Galveston County.

The site has been prepared under a separate contract. This proposer has visited the site to become familiar with the existing conditions.

This fueling station shall be connected to other buildings on the campus (the Eddie Barr Annex and the Road and Bridge Facility) for power and tele communications. Coordination of all electric and tele communication connectivity is the responsibility of this proposal.

The proposal includes the engineering (design) and installation of the following fueling equipment and construction:

- One - ConVault 2,000 Gallon Aboveground Storage Tank for unleaded gasoline service.
- One - connection for future 3,000 Gallon aboveground storage tank for diesel service
- Two – ¾ Horsepower Submersible Pumps

Galveston County Project 09-012a

- One – Fuel Management System – Fuel Force fully coordinated and integrated into the City of Galveston system (the County of Galveston uses the City of Galveston system and this station will be an extension of that program)
- Two – Product Dispensers with pulsars, all stainless steel panels, hose and nozzle assemblies, external filters and internal lighting.
- One – Automatic Tank Gauge System with inventory probes, interstice and sump leak sensors
- One – Building approximately 8 foot square to house and secure the fuel system controllers. The building is to be constructed of painted 8” split face CMU with wood framed roof and overhangs to replace the original structure but at a more flood resistant elevation.
- Double wall fiberglass underground piping and single wall welded steel aboveground piping with dispenser and transition sumps.
- All necessary Tank and Piping apparatuses
- Federal, State and Local Code Compliant Fueling System Design and Installation
- Spill Prevention, Control and Countermeasure (SPCC) Plan
- All Labor, Material and Installation
- Stainless steel doors with card key access integrated with the existing County wide system of card key access.
- Fiber optic connection to the County network hub in the Eddie Barr Annex (approximately 700 lf of underground conduit and necessary length of cable- verify length in the field) - The cabling shall be OSP rated, 12 strand, 62.5 micron, multimode fiber to connect the buildings together. Another contract will provide fiber trays for each end as well as the SC patch ports. Provide a total of four (4) fiber pairs terminated by this contract.
- Fiber Optic connection to Road and Bridge Facility via existing conduit to the tele/data closet in the new Road and Bridge Facility (approximately 300 lf – verify length in the field) - The cabling shall be OSP rated, 12 strand, 62.5 micron, multimode fiber to connect the buildings together. Another contract will provide fiber trays for each end as well as the SC patch ports. Provide a total of four (4) fiber pairs terminated by this contract.
- One Year Warranty from date of acceptance
- Drawing sheets 1 through 4 dated March 28, 2015.
- The agreement includes all information submitted by the Contractor for Proposal B151018

Galveston County Project 09-012a

Section 1.02 The Contractor shall be held accountable for the following Project related responsibilities: furnish all labor and supervision; furnish, supply and install all equipment, material, supplies, tools, scaffolding, hoisting, transportation, unloading and handling; do all things required to complete the work described above on the Project all in accordance with the drawings and Project Manual prepared by the Architect or Engineer; and furnish all necessary information, shop drawings, details, samples, brochures, etc. For Owner/Architect or Engineer approval, as may be required.

Article II.

Time of Commencement and Completion

Section 2.01 The Contractor shall start the work upon notice to proceed and shall execute the work with diligence and dispatch so as to maintain such schedules and milestones as established by Galveston County's authorized Representative. The Contractor agrees to complete portions and the whole of the work by the following anticipated dates: September 18, 2015

Section 2.02 The Contractor is cautioned that schedules and milestones are subject to review and revision, and in such event, such revisions will be made available for the Contractor's information at the office of Galveston County's authorized Representative. In the event the Contractor should fail to maintain Galveston County's authorized Representative's progress schedule or the schedule as established above, Galveston County reserves the right, after 48 hours formal notice, either by letter or telegram to the Contractor, to procure the materials, equipment, and labor necessary to proceed with, or to complete the work, or any portion thereof from other sources and charge the cost thereof to the Contractor.

Section 2.03 Time is of the essence in this Agreement.

Article III.

The Contract Sum

Section 3.01 Galveston County agrees to pay the Contractor for the satisfactory performance of his work the total sum of:

_____ Dollars and xx/100

(\$ _____), payments to be made as described herein in current funds subject to additions and deductions for changes, as may be agreed upon in writing, and to make payments on account thereof as follows:

Section 3.02 On the established day of each month, the Contractor shall deliver to Galveston County through Galveston County's authorized Representative a detailed, quadruplicate statement acceptable to Galveston County's authorized Representative, and if required, supported by receipts, vouchers, etc. showing values of all materials delivered and work completed up to the established billing date for which payment is requested. Monthly and final payments will be made to the Contractor from Galveston County. It is specifically understood and agreed that prior to submission of the first statement, the Contractor will deliver to Galveston County's authorized Representative, for review and approval, a detailed breakdown of this contract sum

Galveston County Project 09-012a

showing a schedule of values for the various parts of the work. Once accepted by Galveston County's authorized Representative, this schedule of values will be used as a basis for checking the Contractor's monthly statement.

Section 3.03 The Contractor shall, with the second and each succeeding monthly request for payment, submit receipts and/or an affidavit and waiver of bond claim showing all payments made for labor and materials and on account for all work covered in the previous months request for payment. Affidavit and waiver of bond claims may be required to be submitted from Contractors, suppliers, and/or Sub-Contractors (all tier). The Contractor shall be required to execute a general release satisfactory to Owner, prior to receiving final payment.

Section 3.04 Five percent (5%) of each payment shall be retained, unless specific provisions to the contrary are indicated in the contract documents.

Section 3.05 No payment made under this Agreement, including the final payment, shall be conclusive evidence of the performance of the work, either wholly or in part, and no payment shall be construed as an acceptance of defective work or improper materials.

Section 3.06 The Contractor shall save and keep Galveston County's authorized Representative, Galveston County and Galveston County's property free from all claims, including bond claims, legal or equitable, arising out of the Contractor's work hereunder. In the event any such claim is filed by anyone claiming by, through, or under the Contractor, the Contractor shall remove and discharge same, by bonding or otherwise, within five (5) days of the filing thereof.

Article IV.

The Contract Documents

Section 4.01 The contract documents consist of this Agreement and any exhibits attached hereto; Proposal Documents, Proposal Form, General Conditions of the Contract, the Project Manual, the Drawings, and all addenda issued prior to and all modifications issued after execution of the Agreement between Galveston County and Galveston County's authorized Representative and agreed upon by the parties.

Section 4.02 The Contractor agrees to perform the work subject to the final approval of the authorized representative of Galveston County, in accordance with the contract documents.

Section 4.03 Contract documents are available, at reasonable times, at the office of Galveston County's authorized Representative for examination by the Contractor.

Section 4.04 No extra work shall be performed under this Agreement, except upon receipt of a written order from Galveston County's authorized Representative or Galveston County.

The Specifications and Drawings are enumerated as follows:

Request for Design Build Services dated March 28, 2015
Proposal Documents submitted by the Contractor.

Galveston County Project 09-012a

Article V.

Insurance and Indemnity

Section 5.01 The Contractor agrees to, at the time of execution of this Agreement, furnish Galveston County's authorized Representative with certificates of insurance from an insurance company (or other source) acceptable to Galveston County. These certificates should certify that the Contractor is protected on the work with worker's compensation and employer's liability, public liability and bodily injury, property damage insurance, and any other insurance as required by the contract documents and in accordance with the attachment to this Agreement. The Contractor will not be permitted to start work at the site until these certificates are filed with Galveston County. Compliance by the Contractor with the foregoing requirements, as to carrying insurance and furnishing certificates, shall not relieve the Contractor of its liabilities and obligations.

Section 5.02 For ten (\$10.00) dollars and other good and valuable consideration, the receipt whereof is hereby acknowledged, and to the fullest extent permitted by law, the Contractor agrees to indemnify and hold harmless Galveston County, Galveston County's authorized Representative, the Architect or Engineer, and all of their agents and employees from and against claims, damages, losses and expenses, including but not limited to attorneys' fees arising out of or resulting from the performance or failure in performance of the Contractor's work under this Agreement provided that any such claim, damage, loss, or expense (1) is attributable to bodily injury, sickness, disease, or death, or to injury to or destruction of tangible property including the loss of use resulting therefrom, (2) is caused, in whole or in part, by any negligent act or omission of the Contractor or anyone directly or indirectly employed by the Contractor, or anyone for whose acts the Contractor may be liable, regardless of whether caused in part by a party indemnified hereunder. Such obligations shall not be construed to negate, abridge, or otherwise reduce any other right or obligation of indemnity which would otherwise exist as to any party or person described in this paragraph. In any and all claims against Galveston County's authorized Representative, or any of its agents or employees, by any employee of the Contractor, or anyone directly or indirectly employed by the Contractor, or anyone for whose acts he may be liable, the indemnification obligation under this paragraph 5.02 shall not be limited in any way by any limitation on the amount or type of damages, compensation, or benefits payable by or for the Contractor under worker's compensation acts, disability benefit acts, or other employee benefit acts.

Section 5.03 The obligations of the Contractor, under paragraph 5.02, shall not extend to the liability of the Architect or Engineer, his agents, or employees, arising out of the preparation or approval of maps, drawings, opinions, reports surveys, change orders, designs, or Project Manual and/or the giving of or failure to give directions or instructions by the Architect or Engineer, his agents or employees, providing such giving or failure to give is the primary cause of the injury or damage

Section 5.04 The Contractor agrees to obtain, maintain, and pay for such contractual liability insurance coverage and endorsements as will insure the indemnification obligation of the Contractor pursuant to paragraph 5.02 above.

Galveston County Project 09-012a

Article VI.

Performance Bond and Labor and Material Payment Bond

Section 6.01 The Contractor agrees to furnish and pay for a 100% Performance Bond and a 100% Labor and Material Payment Bond on the bond forms issued with this Agreement naming the Galveston County as Obligee. Bonds must be issued by a company acceptable to Galveston County and must be accompanied by a Power of Attorney. The bonds are to be delivered with this executed Agreement.

Article VII.

Warranty

Section 7.01 The Contractor agrees to promptly make good, without cost to Galveston County, any and all defects, due to faulty workmanship and/or materials, which may appear within the guarantee or warranty period so established in the contract documents. If no such period is stipulated in the contract documents, then such guarantee shall be for a period of one (1) year from date of substantial completion and acceptance of the work by Galveston County. The Contractor further agrees to provide any and all guarantees as required by the terms of the contract documents, as a condition precedent to final payment

Article VIII.

Changes in the Work

Section 8.01 The Contractor may be ordered in writing by Galveston County, without invalidating this Agreement, to make changes in the work within the general scope of this Agreement. These changes may consist of additions, deletions, or other revisions, the contract sum and the contract time being adjusted accordingly. The Contractor, prior to the commencement of such changed or revised work, shall submit promptly to Galveston County's authorized Representative written copies of any claim for adjustment to the contract sum and contract time for such revised work in a manner consistent with the contract documents

Section 8.02 Where changes in the work involve both additions and deletions, percentages for overhead and profit shall be applied to the net increase of such values for labor and materials.

Section 8.03 The amount to be paid by Galveston County for changes in the work, as outlined in paragraph 8.01 above, shall be made on the basis of one of the following methods:

- a) by mutual acceptance of a lump sum properly itemized and supported by sufficient substantiating data to permit evaluation and agreed upon by Galveston County's authorized Representative and the Contractor, or
- b) by unit prices stated in the contract documents, or
- c) if no such unit prices are set forth and if the parties cannot agree upon a lump sum, then the actual net cost in money to the Contractor of materials and labor (including insurance and applicable taxes) required, plus rental of plant equipment (other than small tools and small equipment) plus compensation for overhead and for profit as noted in Article 12. (Field overhead will not be considered as part of actual net cost), or
- d) by the method provided in subparagraph 8.04.

Galveston County Project 09-012a

Section 8.04 If none of the above methods set forth in clauses 8.03 (a), 8.03 (b), 8.03 (c) is agreed upon, the Contractor, provided he receives a written order signed by Galveston County shall promptly proceed with the work involved. The cost of such work shall be determined by Galveston County's authorized Representative on the basis of reasonable expenditures and savings of those performing the work attributable to the change, including, in the case of an increase in the contract sum, a reasonable allowance for overhead and profit. In such case, and also under clauses 8.03 (c) and 8.03 (d) above, the Contractor shall keep and present, in such form as Galveston County's authorized Representative may prescribe, an itemized accounting together with appropriate supporting data for inclusion in a change order. Unless otherwise provided in the contract documents, cost shall be limited to the following: cost of materials including cost of delivery, cost of labor including social security, old age and unemployment insurance and fringe benefits required by Agreement or custom; workers or workmen's compensation insurance; bond premiums; rental value of equipment and machinery; and the additional costs of supervision and field office personnel directly attributable to the change. Pending final determination of cost, payments, on account shall be made as determined by Galveston County. The amount of credit to be allowed by the Contractor for any deletion or change which results in a net decrease in the contract sum will be the amount of the actual net cost as confirmed by Galveston County. When both additions and credits covering related work or substitutions are involved in any one change, the allowance for overhead and profit shall be figured on the basis of the net increase, if any with respect to that change.

Section 8.05 Owner's Audit

- a) Owner's duly authorized representative shall have access, at all reasonable times, to all Contractor's personnel, books, records, correspondence, instructions, plans, drawings, receipts, vouchers and memoranda of every description pertaining to any change(s) for the purpose of auditing and verifying Contractor's net cost of change or for any other reasonable purpose. Owner's representative shall have the right to reproduce any of the aforesaid documents. Contractor shall preserve, and shall cause its Contractors to preserve all the aforesaid documents for a period of two years after the completion and acceptance or termination of work.

Section 8.06 For work performed by a Sub-Contractor, the Contractor will be allowed to add 5% only and said Sub-Contractor mark-up shall not exceed the agreed upon percentages noted in Article 12 for overhead and profit

Galveston County Project 09-012a

Article IX.

Contractor Responsibilities

Section 9.01 The Contractor shall provide sufficient, safe, and proper facilities at all times for the inspection of the work by Galveston County and Galveston County's authorized Representative, or their authorized representatives. The Contractor shall, within a 24-hour notice from Galveston County's authorized Representative, proceed to take down all portions of the work and remove from the grounds or buildings, all materials, whether worked or un-worked, which Galveston County's authorized Representative, Galveston County, or their authorized representatives shall condemn as unsound or improper, or as in any way failing to conform to the contract documents. The Contractor shall make good at its own expense, all work damaged or destroyed thereby

Section 9.02 The Contractor agrees, in the performance of this Agreement, to comply with all federal, state, municipal, and local laws, ordinances, codes and governing regulations, to pay all costs and expenses required thereby; to pay all fees, charges, assessments, and taxes, and to pay all fringe and other benefits required by Agreement or law.

Section 9.03 The Contractor shall pay all royalties and license fees. He shall defend all suits or claims for infringement of any patent rights and shall save Galveston County, Galveston County's authorized Representative, and Architect or Engineer harmless from loss on account thereof, except that Galveston County shall be responsible for all such loss when a particular design, process or the product of a particular manufacturer or manufacturers is specified, but if the Contractor has reason to believe that the design, process or product specified is an infringement of a patent, he shall be responsible for such loss unless he promptly gives such information to Galveston County.

Section 9.04 Should the Contractor become insolvent, or at any time, refuse or neglect to supply a sufficiency of properly skilled workers, or equipment and materials of the proper quality, or fail in any respect to prosecute the work with promptness and diligence, or fail in the performance of any of the Agreements herein contained, Galveston County shall be at liberty, after 48 hours written notice to the Contractor, to provide any such labor, equipment, and materials and deduct the cost thereof, from any money then due or thereafter to become due to the Contractor, under this Agreement. In the event of such refusal, neglect, or failure Galveston County shall also be at liberty to terminate the employment of the Contractor. Consequently, Galveston County may enter upon the premises to take possession, for the purpose of completing the work included under this Agreement, of all materials, tools, and appliances thereon, and to employ any other person or persons to finish the work and provide the materials therefore. In case of such discontinuance of the employment, the Contractor shall not be entitled to receive any further payment under this Agreement until the said work shall be wholly finished. If the unpaid balance of the amount to be paid under this Agreement shall exceed the expense incurred by Galveston County in finishing the work, such excess shall be paid by Galveston County to the Contractor. If such expense shall exceed such unpaid balance, the Contractor shall pay the difference to Galveston County. The expense incurred by Galveston County, as herein provided, either for furnishing materials, or finishing the work, and any damage incurred through such default, shall be chargeable to the Contractor

Galveston County Project 09-012a

Section 9.05 Notwithstanding the above paragraph, Galveston County reserves the right to terminate this Agreement for its convenience upon written notice to the Contractor. In such instance the Contractor will be paid its share of the contract amount proportionate to the percentage of its work completed and other reasonable cancellation costs incurred as a result of said termination. No payments shall be made for anticipated overhead and profit. Prior to making any payments under this clause, the Owner shall have the right to audit the records of the Contractor

Section 9.06 The Contractor agrees to adhere to the federal Occupational Safety & Health Act, state and local safety regulations and Galveston County's authorized Representative's safety and health program so as to avoid injury or damage to persons or property, and to be directly responsible for damage to persons and property resulting from failure to do so.

Section 9.07 In the event the Contractor after a 24-hour written notice from Galveston County, Galveston County's authorized Representative, or duly authorized representative, fails to take corrective action to insure compliance with said safety regulations or removal of rubbish and debris resulting from his work, Galveston County shall undertake these obligations and charge the cost of same to the Contractor's account without further notice to the Contractor.

Section 9.08 The Contractor agrees to notify Galveston County's authorized Representative's representative on the jobsite of all accidents which may occur to persons or property and shall provide Galveston County's authorized Representative's representative with a copy of all accident reports on appropriate forms. All reports shall be signed by the Contractor or his authorized representative and submitted within five (5) days of occurrence

Section 9.09 The Contractor shall procure its materials from such sources, and employ such labor subject to contract terms and conditions in order to ensure harmonious labor relations on the site and prevent strikes or labor disputes by its employees or other trade employees. The Contractor, in the event of a labor dispute including strikes, shall take whatever action is required in order to prevent the disruption of work on the Project site.

Section 9.10 The Contractor will not assign this Agreement, nor any moneys due or to become due under this Agreement, nor sublet the whole or any part of the work to be performed hereunder, without the written consent of the Owner and Galveston County's authorized Representative. In the event of such a consent, a Sub-Contractor must comply with all the requirements of this Agreement.

Section 9.11 The Contractor agrees that all disputes concerning the jurisdiction of trades shall be adjusted in accordance with any plan for the settlement of jurisdictional disputes which may be in effect either nationally or in the locality in which the work is being done. The Contractor shall be bound by, and shall abide by, all such adjustments and settlements of jurisdictional disputes, whether or not the Contractor is signature bound by the Agreement establishing the impartial jurisdictional disputes board and/or its successors. The Contractor agrees not to cause a work stoppage, due to the jurisdictional assignment of work

Section 9.12 The Contractor shall submit to Galveston County's authorized Representative upon request, copies of orders placed for the various materials required for the Project or authentic stock lists if such material is normally a stock item. Order copies need not reflect

Galveston County Project 09-012a

prices but should indicate type of material, quantity, vendor name, and address, etc. The Contractor shall be required to submit to Galveston County's authorized Representative a monthly material status report, or more often if required by Galveston County's authorized Representative, as a prerequisite for the monthly progress payment. The Contractor shall notify Galveston County's authorized Representative immediately upon learning of a change of status of any material, equipment, or supplies

Section 9.13 The Contractor shall continuously and adequately protect all his work and will immediately replace all damaged and defective work

Section 9.14 The Contractor agrees to maintain an adequate force of experienced workers and the necessary materials, supplies, and equipment to meet the requirements of Galveston County's authorized Representative and other trades in order to maintain construction progress schedules, as established by Galveston County's authorized Representative. In the event that his force is, in the judgment of Galveston County's authorized Representative, inadequate to meet the established schedules during the regular working hours, the Contractor agrees to work sufficient overtime hours or increase his work force to meet such schedules at no extra cost to Galveston County. If for reasons not already stated, Galveston County's authorized Representative requires and directs the Contractor to work overtime, including Saturdays, Sundays or Holidays, the Contractor will be reimbursed the net premium rate only. The net premium rate is understood to mean the actual premium labor cost, including applicable taxes and wage additives required by trade Agreement or by law, but without additives for overhead, labor efficiency, or profit.

Section 9.15 The Contractor agrees to employ competent administrative, supervisory, and field personnel to accomplish the work, including layout and engineering and preparation and checking of shop drawings. If required, the Contractor shall substantiate this employment of competent personnel to Galveston County's authorized Representative's satisfaction before initiating any work

Section 9.16 The Contractor shall insure that all construction tools, equipment, temporary facilities, and other items used in accomplishing the work, whether purchased, rented, or otherwise provided by the Contractor or provided by others, are in a safe, sound, and good condition, must be capable of performing the functions for which they are intended and must be maintained in conformance with applicable laws and regulations

Section 9.17 If the Contractor is delayed at any time in the progress of the work by any act or neglect of the Owner, Galveston County's authorized Representative, or the Architect or Engineer, or by any employee of either, or by any separate contractor employed by the Owner, or by changes ordered in the work, or by labor disputes, fire, unusual delay in transportation, adverse weather conditions not reasonably anticipatable, unavoidable casualties or any causes beyond the Contractor's control, or by delay authorized by the Owner or Galveston County's authorized Representative, or by any other cause which Galveston County's authorized Representative determines may justify the delay, then the contract time shall be extended by amendment for such reasonable time as Galveston County's authorized Representative and Owner may determine.

Section 9.18 Right-To-Know each Contractor is required to implement the provisions of the right-to-know law, if any, as enacted by the state in which the work is being performed. Before

Galveston County Project 09-012a

using on site any material listed in the right-to-know substance list, each Contractor will furnish Galveston County's authorized Representative a copy of the material safety data sheet for that substance

Section 9.19 In the event the Contractor employs independent contractors, as well as payroll labor, to discharge its obligations hereunder, the Contractor acknowledges and understands that it does so at its own risk and that federal, state and/or local agencies may dispute the independent contractor status and assess penalties, fines, and costs should there be a determination to reclassify such workers. In that event, the Contractor agrees that it will defend, indemnify and hold Galveston County harmless from any fines, costs, damages, penalties, attorneys fees, and causes of action, including without limitation, personal injury or property damage, arising out of or relating in any way to such a determination.

Article X.

Galveston County's authorized Representative Responsibilities

Section 10.01 Galveston County's authorized Representative will be the Owner's representative and will administer the contract as described in the contract documents. Galveston County's authorized Representative will advise and consult with the Owner. Galveston County's authorized Representative will have authority to act on behalf of the Owner to the extent provided in the contract documents, as they may be modified by change order in accordance with other provisions of the trade contract

Section 10.02 The Contractor agrees to perform the work under the general direction and coordination of Galveston County's authorized Representative in accordance with the contract documents. Any directive given by Galveston County's authorized Representative shall be binding on the Contractor.

Section 10.03 Galveston County's authorized Representative, acting for the Owner and subject to the Owner's delegation of such authority, may perform all tasks necessary or appropriate to administer and manage the trade contract, and undertake any action with respect to the Contractor, that the Owner is entitled to undertake.

Section 10.04 Galveston County's authorized Representative shall not give instructions or orders directly to employees or workers of the Contractor, except to persons designated as authorized representatives of the Contractor.

Galveston County Project 09-012a

Article XI.

Equal Opportunity

Section 11.01 During the performance of this Agreement, the Contractor agrees not to discriminate against any employee or applicant for employment because of race, color, religion, sex, or national origin. The Contractor will take affirmative action to insure that applicants are employed without regard to their race, color, religion, sex, or national origin. The Contractor will comply with all provisions of Executive Order No. 11246, Section 503 of the Rehabilitation Act of 1973, as Amended, the Vietnam Era Veterans' Readjustment Assistance Act of 1974, as Amended, (38 U.S.C. 4212) and their implementing regulations at 41 CFR Chapter 60.

Article XII.

Alterations

Section 12.01 Refer to the Proposal Form for the overhead and profit allowable under Article 8.03. A, 8.03 B, 8.03 C: _____% Overhead, _____% Profit

Article XIII.

Complete Agreement

Section 13.01 This Agreement, together with all documents, Project Manual, drawings, incorporated herein by reference, constitute the entire Agreement between Galveston County and Contractor. There are no terms, conditions, or provisions, either oral or written, between the parties hereto, other than those contained herein. This Agreement supersedes any and all written representations, inducements, or understandings of any kind or nature between the parties hereto, relating to the particular Project involved herein

Section 13.02 The said parties for themselves, their heirs, successors, executors, administrators and assigns, do hereby agree to the full performance of the covenants herein contained.

Galveston County Project 09-012a

This Contract is issued pursuant to award made by Commissioners' Court on _____, 20__.

EXECUTED this ____ day of _____, 20__.

COUNTY OF GALVESTON, TEXAS

BY:

Mark Henry, County Judge

ATTEST:

Dwight Sullivan, County Clerk

CONTRACTOR

BY:

Signature - Title

Printed Name

**Crystal Beach Fueling Station
Galveston County
GENERAL CONDITIONS OF THE CONTRACT**

- Article
- 1.....CONTRACT DOCUMENTS
 - a.....The Work
 - b.The Project
 - c.....The Proposal Package
 - d.Abbreviations
 - e.....General Definitions
 - 2.....EXECUTION, CORRELATION, AND INTENT
 - 3.....OWNERSHIP AND USE OF DOCUMENTS
 - 4.....OWNER
 - a.....Definition
 - b.Information and Services Furnished by the Owner
 - 5.....ARCHITECT OR ENGINEER
 - a.....Definition
 - b.Architect or Engineer Duties During Construction
 - 6.....CONSTRUCTION MANAGER
 - a.....Definition
 - b.Administration of the Contract
 - 7.....CONTRACTOR
 - a.....Definition
 - b.Review of Contract Documents
 - c.....Supervision and Construction Procedures
 - d.Labor and Materials
 - 8.....WARRANTY
 - 9.....TAXES
 - 10.....SUPERINTENDENT
 - 11.....DRAWINGS AND PROJECT MANUAL AT THE SITE
 - 12.....USE OF SITE
 - 13.....COMMUNICATIONS
 - 14.....SUB-CONTRACTORS
 - a.....Definition
 - b.Award of Sub-Contractors and other portions of the Work
 - c.....Sub-Trade contractual relations
 - 15.....SEPARATE CONTRACTS
 - a.....Mutual responsibility of Contractors
 - 16.....GOVERNING LAW AND VENUE
 - 17.....INDEMNIFICATION
 - 18.....CLAIM FOR DAMAGES
 - 19.....RIGHTS AND REMEDIES
 - 20.....TESTS
 - 21.....INTEREST
 - 22.....TIME
 - a.....Definitions
 - b.Progress and Completion
 - c.....Delays and Extension of Time
 - 23.....PAYMENTS AND COMPLETION
 - a.....Progress Payments
 - b.Payments withheld
 - c.....Failure of Payment
 - d.Substantial Completion
 - e.....Final Completion and Final Payment
 - 24.....PROTECTION OF PERSONS PROPERTY
 - 25.....EMERGENCIES
 - 26.....INSURANCE
 - A.....Contractor Liability Insurance
 - B.....Property Insurance
 - 27.....CHANGES IN THE WORK
 - a.....Change Authorization/Contract Amendments
 - b.Concealed Conditions
 - c.....Claims for Additional Cost
 - 28.....UNCOVERING AND CORRECTION OF WORK
 - a.....Uncovering Work
 - b.Correction of Work

Galveston County Project 09-012a

- 29..... TERMINATION OF THE CONTRACT
 - a.....Termination by the Contractor
 - b.Termination by the Owner or Construction Manager
 - c.....Termination for Convenience
- 30..... TEMPORARY SERVICES AND SYSTEMS
 - a.....Temporary Electric System
 - b.Temporary Heating
 - c.....Temporary Water
 - d.Housekeeping-Cleaning, Rubbish and Trash removal
 - e..... Vehicle Cleaning-Trucking
 - f.Site Security
 - g.Personnel and Property Protection
- 31..... ORDER OF PRECEDENCE
- 32..... WAGE RATES
- 33..... FORCE MAJEURE
- 34..... SALVAGE
- 35..... OPEN RECORDS
- 36..... PERFORMANCE AND PAYMENT BOND(S)

Galveston County Project 09-012a

SECTION 00200 General Terms and Conditions of the Contract

1. Contract Documents

- A. The Work - For the purpose of this document, the term "Work" is the work defined in Article 1 of the Trade Contract
- B. The Project is the total construction to be performed under the Agreement between the Owner and Galveston County's authorized Representative of which the Work is a part.
- C. Proposal Package
1. The project is to be constructed under a multi-contract (Proposal Package) arrangement utilizing multiple contracts. The Scope of Work (description of the portion of work) for each "Proposal Package" including an index of respective Drawings and Project Manual Sections shall be specified in the "Competitive Sealed Proposal Form" which form is a part of each "Proposal Package".
 2. The work to be performed by each separate Contractor shall be as specifically defined in the Proposal Form for each separate Contract (Proposal Package under "Scope of Work") and subsequently inserted in Article 1 of the Agreement. Note: The Scope of Work of a Contract (Proposal Package) may:
 - a. Require work to be performed which is covered under more than one (1) section of the Project Manual; and/or
 - b. Require the performance of one or more items of work which are only a part of the work covered by a section of the Project Manual
 3. Where the Scope of Work of any separate (Proposal Package) requires the performance of an item of work, said item of work shall be performed in full accordance with the requirements of the applicable Sections of the Project Manual, or the applicable part thereof.
- D. Abbreviations
1. The language of the Project Manual and elsewhere in the Contract Documents is of the abbreviated type in certain instances, and implies words and meanings which will be appropriately interpreted.
 2. Actual word abbreviations of a self-explanatory nature have been included in the Project Manual and Drawings. These are generally defined in the Project Manual Sections at the first instance of use of each term so abbreviated.
 3. Singular words will be interpreted as plural and plural words will be interpreted as singular wherever applicable and the full context of the requirements so indicates.
- E. General Definitions
1. The word "County" in this contract refers to the County of Galveston.
 2. The word "Contractor" refers to the person or entity agreeing to perform the work in this contract and is also referred to as the "Contractor"
 3. "Program Administrator" refers to the person designated by County to act on its behalf in administering this contract.
 4. "Provide", or "perform": To supply, install and connect up complete and ready for safe and regular operation of particular work referred to unless specifically noted otherwise.
 5. "Furnish" to supply, deliver to site and transfer to others for installation.
 6. "Install": To receive, unload, distribute, construct, erect, mount, and connect complete with related accessories.
 7. "Supply": To purchase, procure, acquire and deliver complete with related accessories.
 8. "Product": The term "product" shall include materials, equipment and systems.
 9. "As approved": Where used in conjunction with the Galveston County's authorized Representative's or the Architect or Engineer's response to submittals, requests, applications, inquiries, reports and claims by the Contractor, the meaning of the term "approved" shall not exceed the limitations of the Galveston County's authorized Representative's or the Architect or

Galveston County Project 09-012a

- Engineer's responsibilities and duties as established in the contract documents.
- a. In no case shall "approval" by Galveston County's authorized Representative or the Architect or Engineer be interpreted as a release of the Contractor from responsibilities to fulfill the requirements of the Contract Documents.
 - b. "Approval", where required for an item, shall be obtained from the Architect or Engineer through Galveston County's authorized Representative in writing.
10. The term "Indicated" is a cross reference to details, notes, or schedules on the drawings, other paragraphs or schedules in the Project Manual, and similar means of recording requirements in the Contract Documents.
- a. Where terms such as "shown", "noted", "scheduled", and "specified" are used instead of "indicated, it is for purpose of helping the reader accomplish the cross reference, and no limitation of location is intended except as specifically noted.
11. "Directed", "Requested", Etc.: Where not otherwise explained, terms such as "directed", "requested", "authorized", "selected", "approved", "required", "accepted", and "permitted" mean "directed by the Architect or Engineer, Galveston County's authorized Representative or Owner's Representative", "requested by the Architect or Engineer, Galveston County's authorized Representative or Owner's Representative", etc. However, no such implied meaning will be interpreted to extend the Architect or Engineer's or Galveston County's authorized Representative's responsibility in the Contractor's area of construction supervision.
12. "Installer": The person or entity engaged by the Contractor or his or Sub-Contractor for the performance of a particular unit of work at the project site, including installation, erection, application and similar required operations. It is a general requirement that installers be recognized experts in the work they are engaged to perform.
13. "Suitable", "reasonable", "proper", "correct" and "necessary": Such terms shall mean as suitable, reasonable, proper, correct, or necessary for the purpose intended as required by the contract documents, subject to the judgment of the Architect or Engineer or Galveston County's authorized Representative.
14. "Including", "Such as": The terms "including" and "such as" shall always be taken in most inclusive sense, namely, "including, but not limited to", and "such as, but not limited to"
15. "Option": The term "option" shall mean a choice from the specified products or procedures which shall be made by the Contractor. The choice is not "whether" the work is to be performed, but "which" product or "which" procedure is to be used. The product or procedure chosen by the Contractor shall be provided at no increase in the cost to the Owner and with no lessening of the Contractor's responsibility for its performance.
16. "Exposed": The term "exposed" shall mean any item or surface, exterior or interior, which can be seen by a person outside the building, or seen by a person inside any usable space within the building during normal activity.
- a. Mechanical and electrical rooms, air handling rooms, storage rooms and penthouses shall be considered to have exposed surfaces, as shall the mechanical and electrical construction within them.
 - b. The interiors of closets and alcoves shall be considered exposed surfaces, and shall be finished to match the finish of the adjoining room or space, unless another finish is shown.
 - c. The interiors of cabinets shall be considered exposed, but a finish different from that of the exterior may be permitted or required.
 - d. Spaces which are not normally occupied or used by occupants or building staff, such as, shafts, hoist ways, tunnels, ceiling plenums, attics, and crew spaces shall be considered "concealed" spaces, unless finishes are shown or specified for their surfaces
17. "At no additional cost": The term "at no additional cost" shall mean at no additional cost to the Owner, the Architect or Engineer, or Galveston County's authorized Representative.
18. "Testing Laboratory": An independent entity engaged to perform specific inspections or tests of the Work, either at the project site or elsewhere; and to report and interpret the results of those inspections or tests.
19. Where the word "similar" appears on the drawings, it shall be interpreted in its general sense and not as meaning identical and all details shall be worked out in relation to their location and connection with other parts of the Work.

Galveston County Project 09-012a

- a. Where on any drawings a portion of the Work is drawn out and the remainder is indicated in outline, the parts drawn out shall also apply to parts outlined.

2. Executions, Correlation, and Intent

- A. By executing his Agreement, Contractor represents that he has visited the site, familiarized himself with the local conditions under which the Work is to be performed and correlated his observances with the requirements of the Contract Documents. Claims, as a result of failure to do so, will not be considered.
 1. The Contract shall be signed in triplicate by the Owner and Contractor.
- B. The intent of the Contract Documents is to include all items necessary for the proper execution and completion of the Work. The Contract Documents are complementary, and what is required by any one shall be as binding as if required by all. Work not covered in the Contract Documents will not be required unless it is consistent therewith and is reasonably inferable therefrom as being necessary to produce the intended results. Words and abbreviations in the Contract Documents which have well known technical or trade meanings are used in accordance with such recognized meanings
- C. The organization of the Project Manual into divisions, sections and articles, and the arrangements of Drawings shall not control Galveston County's authorized Representative in dividing the Work among Contractors or in establishing the extent of Work to be performed by any trade
- D. Written interpretations necessary for the proper execution or progress of the Work, in the form of drawings or otherwise, will be issued with reasonable promptness by the Architect or Engineer through Galveston County's authorized Representative and in accordance with any schedule agreed upon. The Contractor shall make written request through Galveston County's authorized Representative to the Architect or Engineer for such interpretations. Such interpretations shall be consistent with and reasonably inferable from the Contract Documents. The Contractor shall execute and complete the Work in accordance with such interpretations.

3. Ownership and Use of Documents

- A. Unless otherwise provided in the Contract Documents, the Contractor will be furnished, free of charge, three (3) sets of Working Drawings and Project Manual reasonably necessary for the execution of the Work.
- B. All Drawings, Project Manual and copies thereof furnished by the Architect or Engineer are and shall remain his property. They are to be used only with respect to this Project and are not to be used on any other project. With the exception of one contract set for each party, such documents are to be returned or suitably accounted for to the Architect or Engineer on request at the completion of the Work. Submission or distribution to meet official regulatory requirements or for other purposes in connection with the Project is not to be construed as publication in derogation of the Architect or Engineer's common law copyright or other reserved rights.

4. Owner

- A. The Owner for this project is:

Galveston County
722 Moody, Suite 200
Galveston, Texas 77550

The Owner is the person or entity identified as such in the Agreement between the Owner and Contractor and is referred to throughout the Contract Documents as if singular in number and masculine in gender. The term "Owner" means the Owner or his authorized representative.

- B. Information and Services furnished by the Owner.
 1. The Owner will furnish all surveys describing the physical characteristics, legal limitations and utility locations for the site of the Project, and a legal description of the site.
 2. Except as provided in Article 9.2 of the Trade Contract the Owner will secure and pay for necessary approvals, easements, assessments and charges required for the construction, use, or occupancy of permanent structures or for permanent changes in existing facilities.
 3. Information or services under the Owner's control will be furnished by the Owner with reasonable promptness to avoid delay in the orderly progress of the Work.
 4. The Owner shall forward all instructions to the Contractors through Galveston County's authorized Representative.

Galveston County Project 09-012a

5. Galveston County's authorized Representative

A. Definition

1. Galveston County's authorized Representative or this project is: J. Dudley Anderson, County Architect
2. Galveston County's authorized Representative is the person or entity who has entered into an agreement with the Owner to serve as Galveston County's authorized Representative and is referred to throughout the Contract Documents as if singular in number and masculine in gender.
3. It is the intent of these General Conditions to allow Galveston County's authorized Representative to direct and schedule the performance of all Work and the Contractors are expected to follow all such directions and schedules.

B. Administration of the Contract

1. Galveston County's authorized Representative will provide, as the Owner's authorized representative, the general administration of the Project as described herein and in Article 10 of the Agreement between Galveston County and Contractor.
2. Galveston County's authorized Representative will be the Owner's Construction Representative during construction until final payment and shall have the responsibility to manage the work of all Contractors.
3. Galveston County's authorized Representative shall have the authority to reject Work, which does not conform to the Contract Documents, and to require any Special Inspection and Testing in accordance with Subparagraph 20.B.
4. Galveston County's authorized Representative will prepare and issue Amendments (Changes in the Work) to the Contractors in accordance with Article 27.
5. Galveston County's authorized Representative, along with the Architect or Engineer, will conduct site visits to determine the dates of Substantial Completion and Final Completion, and will receive and review written warranties and related documents required by the Contract and assembled by the Contractor.
6. Galveston County's authorized Representative may call for meetings of the Contractors, Sub-Contractors, and material suppliers, as he deems necessary for the proper coordination of the work. Such meetings shall be held at the jobsite on regular working days during regular working hours. Unless otherwise directed by Galveston County's authorized Representative, attendance shall be mandatory for all parties notified.

6. Contractor

A. Definition

1. Contractor is the person or entity identified as such, and is referred to throughout the Contract Documents as if singular in number and masculine in gender. The term Contractor means the Contractor or his authorized representative.
2. In the Project Manual, the word "contractor" shall mean and shall be interpreted as being the "Contractor" whose "scope of work" and Project Manual index includes that portion of the work. In these General Conditions the word "contractor" and/or "Contractor" shall mean and shall be interpreted as being "individually, each and every Contractor".
3. The Contractor shall at all times be considered to be an independent contractor, and will not hold itself or its employees out to be employees or agents of the County of Galveston.
4. The Contractor will retain full control over this contract and will not assign said contract without the prior written consent of the County.

B. Review of Contract Documents

1. The Contractor shall carefully study and compare the Contract Documents and shall at once report to Galveston County's authorized Representative any error, inconsistency or omission he may discover. If the Contractor performs any work without reporting any such error, inconsistency, or omission to Galveston County's authorized Representative or contrary to any laws, ordinances, rules, or regulations, and without such notice to Galveston County's authorized Representative, he shall assume full responsibility therefore and shall bear all costs attributable thereto.

C. Supervision and Construction Procedures

Galveston County Project 09-012a

1. All work shall be performed and completed in a thorough, workmanlike manner and in accordance with the latest proven practices of the trade by thoroughly skilled and experienced workers.
2. The Contractor shall supervise and direct the Work, using his best skill and attention. He shall be solely responsible for all construction means, methods, techniques, sequences and procedures and for coordinating all portions of the Work under the Contract subject to the overall coordination of Galveston County's authorized Representative.
3. Galveston County's authorized Representative may reject any means, methods, techniques, sequences or procedures proposed by the Contractor, which might constitute or create a hazard to the Work, or to persons or property, or which will not provide Work in accordance with the Contract Documents
4. The Contractor shall be responsible to the Owner for the acts and omissions of his employees and all his Sub-Contractors and their agents and employees and other persons performing any of the Work under a contract with the Contractor.
5. Neither observations nor site visits, tests or approvals by persons other than the Contractor shall relieve the Contractor from his obligations to perform the Work in accordance with the Contract Documents. The Contractor shall do and be responsible for the correct laying out of the Work as per drawings and written instruction of Galveston County's authorized Representative including all necessary leveling and checking. The Contractor shall check the established grades and bench marks, and shall lay out all partition lines and other significant reference lines or points which will enable them to accurately place their boxes, openings, sleeves, conduits, pipe duct, controls, hangers, inserts and other devices. Subcontractors shall be responsible for laying out their Work from these reference points.

D. Labor and Materials

1. The Contractor is encouraged to use local labor, but not at the expense of poor workmanship and higher cost.
2. The Contractor and all Sub-Contractors shall not discriminate against any employee or applicant for employment because of race, color, sex, or national origin.
3. The Contractor shall post in conspicuous places, available to employees and applicants for employment, notices setting forth the policies of non-discrimination.
4. In the event of Contractor's non-compliance with the non-compliance clause of this Contract, the Contract entered into may be canceled in whole or part.
5. The Contractor shall at all times enforce strict discipline and good order among his employees and shall not employ on the Work any unfit person or anyone not skilled in the task assigned to him. Obnoxious behavior, possession, or consumption of alcoholic beverages or drugs on the premises is strictly prohibited. Violators shall be promptly discharged from the site.
6. The Contractor shall accept delivery, unload, store, protect, provide security, distribute and install any materials, systems and equipment furnished by others which are a part of the Work. The Contractor shall document receipt of such materials, systems and equipment on forms acceptable to Galveston County's authorized Representative.
7. Whenever the Contractor has knowledge that any actual or potential labor dispute is delaying or threatens to delay the timely performance of the work of this contract, the Contractor shall immediately give notice thereof to Galveston County's authorized Representative. The Contractor shall then confirm the notice, in writing, within 24 hours of the giving thereof and shall include all relevant information with respect thereto. No claims will be accepted for costs incurred as a result of jurisdictional or labor practices disputes.
8. The County is committed to maintaining an alcohol and drug free workplace. Possession, use or being under the influence of alcohol or controlled substances by the Contractor's employees while in the performance of this Contract is prohibited. Violation of this requirement shall constitute grounds for immediate termination of the Contract.

7. Warranty

- A. The Contractor warrants to the Owner that all materials and equipment furnished under this Contract will be new unless otherwise specified, and that all Work will be of good quality, free from faults and defects and in conformance with the Contract Documents. All Work not so conforming to these requirements, including substitutions not properly approved and authorized, may be considered defective. If required by Galveston County's authorized Representative, the Contractor shall furnish satisfactory evidence as to the

Galveston County Project 09-012a

- kind and quality of materials and equipment. This warranty is not limited by the provisions of Paragraph 28.B
- B. The warranty of materials, equipment and workmanship defined in 8.A is separate from, independent of, and in addition to any other guarantees in this contract or any other warranties required by the Contract Documents.
 - C. The Contractor, prior to or at the time of substantial completion for the Work and during administrative closeout of the project, shall submit one copy of all specified warranties and guarantees to Galveston County's authorized Representative for review, approval and subsequent transmittal to the Architect or Engineer and Owner.
 - D. Warranties and guarantees, including those specified in excess of the general one year guarantee shall be complete for all specific materials, systems, sub-systems, equipment, appliances and products specified and required by the Contract Documents.
 - E. Warranties and guarantees shall clearly define what is to be guaranteed; the extent, terms, conditions, time and effective dates.
 - F. Copies of the same warranties and guarantees shall be included in the "Owner's Maintenance Manual" as specified herein.
 - G. Owner's Maintenance Manual: The Contractor, during the course of the work, shall maintain, coordinate and collect copies of warranties, guarantees, certificates, test results, installation drawings, manufacturer's maintenance and operations manuals, parts lists, and keying schedules and at the acceptance of the project, shall assemble this material into a manual and forward to Galveston County's authorized Representative for incorporation in the Operations and Maintenance Manual for the project..
 - H. Warranties shall not commence to run until the Owner:
 - 1. Accepts the work for beneficial occupancy, and
 - a. is in possession of all the specified guarantee/ warranty documentation, and
 - b. has received the specified training for the operation and maintenance of the system/equipment .
 - I. If prior to the acceptance of the Work the Owner occupies or uses any separate unit of the Work, the guarantee period shall, as to the unit so occupied or used, commence on the date of such occupancy or use, with the further provision that the Owner shall have first agreed in writing that the separate unit is complete to such a degree as to permit its use or occupancy and subject to subparagraph 8.H as applicable. No such separate unit shall be occupied or used by the Owner until such certificate has been given. Equipment and facilities, which have seasonal limitations on their operation, shall be guaranteed for one full year from the date of test and acceptance in writing by the Owner.
 - J. If within any guarantee period, repairs or changes are required in connection with the guaranteed Work, as the result of the use of materials, equipment or workmanship, which are defective, or inferior, or not in accordance with the terms of the Contract, the Contractor shall, promptly, within 48 hours after receipt of notice from Galveston County's authorized Representative or Owner and without expense to the Owner or Construction Manager, commence and continue to effect such repairs or changes and:
 - 1. Place in satisfactory condition, in every particular, all of such guaranteed work and correct all defects therein.
 - 2. Make good all changes to the structure, site, equipment, or contents thereof, which, in the opinion of the Architect or Engineer, and Galveston County's authorized Representative is the result of the use of materials, equipment or workmanship, which are inferior, defective, or not in accordance with the terms of the Contract.
 - K. Notifications by Owner or Galveston County's authorized Representative of defects shall stop the warranty time period. The guarantee or warranty period for that replaced or restored work shall be reinstated for the remaining time period, starting on the date of acceptance of the replaced or restored work.
 - L. In any case, where in fulfilling the requirements of the Contract or of any guarantee embraced in or required thereby, the Contractor disturbs any work guaranteed under another contract, he shall restore such work to a condition satisfactory to the Architect or Engineer, and Galveston County's authorized Representative and guarantee such restored work to the same extent as it was guaranteed under such other contract.
 - M. If the Contractor after notice fails to proceed within 48 hours to commence and continue to comply with the terms of the guarantee, the Owner or Galveston County's authorized Representative may have the defect corrected in which case the Contractor and his surety shall be liable for all expenses incurred.
 - N. All special guarantees or warranties applicable to definite parts of the Work that may be stipulated in the

Galveston County Project 09-012a

Project Manual or other papers forming a part of the Contract shall be subject to the terms of this Article during the first year of the life of such special guarantee.

- O. Nothing contained in this Article shall be construed to establish a period of limitation with respect to any other obligation which the Contractor might have under the Contract Documents.
- P. In the event the Work of the Contractor is to be modified by another Contractor, either before or after inspection, the first Contractor shall remain responsible in all respects under the warranty given in Article 8 and under any other warranties provided in the Company Documents or by law. However, the first Contractor shall not be responsible for any defects in material or workmanship introduced by the Contractor modifying its work. Both the first Contractor and the Contractor making the modifications shall each be responsible solely for the work done by each. The Contractor modifying the earlier work shall be responsible for any damage to or defect introduced into the Work which it is modifying.

8. Taxes

- A. The Contractor shall pay all sales, consumer, use and other similar taxes for the Work or portions thereof provided by the Contractor which are legally required at the time Proposals or proposals are received, whether or not yet effective. Such taxes are included in the trade contract sum.
- B. Any taxes which are the responsibility of the Contractor, but are not paid by the Contractor, and which are subsequently assessed against and paid by the Owner shall be deducted by the Owner as an offset from the unpaid Contract Sum and any other amounts due to the Contractor. If the amount of such unpaid taxes exceeds the total of the unpaid Contract Sum and other amounts due to the Contractor, the Contractor agrees to pay the amount of such excess to the Owner.

9. Superintendent and key Personnel

- A. The Contractor shall employ a competent superintendent and necessary assistants who shall be in attendance at the Project site during the progress of the Work. The superintendent shall be satisfactory to Galveston County's authorized Representative, and shall not be changed except with the consent of Galveston County's authorized Representative, unless the superintendent proves to be unsatisfactory to the Contractor or ceases to be in his employ. The superintendent shall represent the Contractor and all communications given to the superintendent shall be as binding as if given to the Contractor. Important communications shall be confirmed in writing. Other communications shall be so confirmed on written request in each case.
- B. A duly authorized representative of the Contractor shall be available for emergency telephone communication from the Owner or Galveston County's authorized Representative on a 24-hour basis, seven days a week during the performance of the work.
- C. The Contractor shall identify the key personnel he intends to assign to the project, to Galveston County's authorized Representative within 48 hours after the Contractor has been notified to proceed. The Owner, acting through Galveston County's authorized Representative, reserves the right to approve the Contractor's proposed personnel, and anyone not so approved shall be immediately replaced by someone acceptable. If, in the course of construction, Galveston County's authorized Representative feels that it would be in his best interest to request a change in the Contractor's personnel, he may do so; and the Contractor shall immediately assign an acceptable replacement at no additional cost.

10. Drawings and Project manual at the site

- A. The Contractor shall maintain at the site for Galveston County's authorized Representative and Architect or Engineer one copy of all Drawings, Project Manual, Addenda, Bulletins, Amendments, and other Modifications, in good order and marked currently to record all changes made during construction. Including any changes in locations, sizing and arrangement of the various components of the Work or any other variations from the Drawings or Shop Drawings. The Contractor shall mark each drawing as the Work shown thereon is completed in the field, revising any or adding lines, dimensions, elevations, depths, notes or any other information required to accurately record "As-Built" conditions. These drawings, marked to record all changes during construction, and approved Shop Drawings, Product Data and Samples shall be delivered to Galveston County's authorized Representative, for the Owner, upon completion of the Work.
- B. In addition to maintaining and delivering to Galveston County's authorized Representative those record Drawings required by Subparagraph 11.A the Contractor shall also prepare and submit to Galveston County's authorized Representative, upon completion of the Work "As-Built" Reproducible Drawings if

Galveston County Project 09-012a

the Project Manual so requires.

11. Use of Site

- A. The owner does not assume any responsibility for any materials, tools, or equipment stored on or about the site.
- B. The Contractor shall confine operations at the site to areas designated by Galveston County's authorized Representative, permitted by law, ordinances, permits and by the Contract Documents, and shall not unreasonably encumber the site with any materials or equipment. The Contractor shall not use any of the existing Owner's facilities, such as, toilets, cafeteria, parking areas, power hookup, etc., except with the Galveston County's authorized Representative's written approval. The Contractor shall not, at any time, block or restrict access to the site.
- C. The Contractor shall coordinate all of his operations with Galveston County's authorized Representative and obtain his approval before using any portion of the project site and the Contractor shall comply with the Galveston County's authorized Representative's Site Utilization Plan.
- D. The roads, sidings and other transportation facilities at the site, where work under the Contract is being performed, are for the general use and convenience of the Owner. If Contractors are permitted to use them, they must conform to the regulations of the local authorities. If the work of a Contractor requires that such facilities be temporarily discontinued, after obtaining Galveston County's authorized Representative's approval, the work must be done expeditiously and he shall provide and maintain proper warnings and detour signs at all pedestrian and vehicular closures, intersections, and along detours, directing traffic around closed portions of roadways. He shall, at his own expense, wherever necessary or required, provide and maintain fences, temporary roadways, temporary cross signs, watchmen, warning lights and take such other precautions as may be necessary to protect life any way by his act or neglect. All barricades and obstructions shall be illuminated at night, and all lights shall be kept on from one half hour before sunset, until one-half-hour after sunrise.
- E. On-site storage space for Contractor's field office trailer, sheds, materials, tools, equipment, and supplies must be coordinated with and approved by Galveston County's authorized Representative in advance. Contractor's materials, equipment, tools and supplies shall be moved at no cost if their location obstructs or impedes the work of others.
- F. Galveston County's authorized Representative will provide site survey, selected baselines and benchmarks.
- G. The Contractor shall not disturb existing monuments and markers at the site. Should monuments, markers, or both be disturbed by the Contractor, he shall bear the cost of a licensed surveyor engaged by Galveston County's authorized Representative for the purpose of relocating such monuments or markers.
- H. Each Contractor shall lay out his work and shall be responsible for the accuracy of all lines, elevations and measurements, grading, utilities, and other work executed by him under his Trade Contract. He must exercise proper precaution to verify figures shown on drawings before laying out work and will be held responsible for any error resulting from his failure to exercise such precaution.

12. Communications

- A. The Contractor shall forward all communications to the Owner and Architect or Engineer through Galveston County's authorized Representative.
- B. The Contractor shall promptly return telephone calls or respond to any other form of communication initiated by Galveston County's authorized Representative. Failure to promptly do so shall be considered lack of performance on the part of the Contractor.
- C. All written correspondence to Galveston County's authorized Representative shall be dated, and signed by the Contractor or his authorized representative.
- D. Written notice shall be deemed to have been duly served if delivered in person to the individual or member of the firm or entity or to an officer of the corporation for whom it was intended, or if delivered at or sent by registered or certified mail to the last business address known to him who gives the notice.

13. Sub-Contractors

- A. Definition
 - 1. A Sub-Contractor is a person or entity who has a direct or indirect contract with a Contractor to perform any of the Work at the site. The term Sub- Contractor is referred to throughout the Contract Documents as if singular in number and masculine in gender and means a Sub-Contractor or his authorized representative.

Galveston County Project 09-012a

2. Nothing in the contract documents shall create any contractual relationship between the Owner, the Architect or Engineer or Galveston County's authorized Representative and any Sub-Contractor of the Contractor.
- B. Award of Sub-trade Contracts and other Contract for Portions of the Work
1. Unless otherwise required by the Contract Documents the Contractor shall furnish to Galveston County's authorized Representative in writing, for acceptance by the Owner and Galveston County's authorized Representative in writing, the names of the persons or entities (including those who are to furnish materials or equipment fabricated to a special design) proposed for each of the principal portions of the Work. The Contractor is encouraged to use Local vendors wherever possible. Galveston County's authorized Representative will promptly reply to the Contractor in writing if either the Owner or Galveston County's authorized Representative, after due investigation, has reasonable objection to any such proposed person or entity. Failure of the Owner or Galveston County's authorized Representative to reply shall constitute notice of no reasonable objection.
 2. The Contractor shall not contract with any such proposed person or entity to whom the Owner or Galveston County's authorized Representative has made reasonable objection under the provision of Subparagraph 14.B.1. The Contractor shall not be required to contract with anyone to whom he has a reasonable objection.
 3. If the Owner or Galveston County's authorized Representative refuses to accept any person or entity on a list submitted by the Contractor in response to the requirements of the Contract Documents, the Contractor shall submit an acceptable substitute; however, no increase in the Contract Sum shall be allowed for any such substitution.
 4. The Contractor shall make no substitution for any Sub-Contractor, person or entity previously selected if the Owner or Galveston County's authorized Representative makes reasonable objection to such substitution.
- C. Sub-trade Contractual Relations
1. By an appropriate written agreement, the Contractor shall require each Sub-Contractor to the extent of the work to be performed by the Sub-Contractor, to be bound to the Contractor by the terms of the Contract Documents, and to assume toward the Contractor all the obligations and responsibilities which the Contractor, by these documents, assumes toward the Owner, Galveston County's authorized Representative, or the Architect or Engineer. Said agreement shall preserve and protect the rights of the Owner, Galveston County's authorized Representative and the Architect or Engineer under the Contract Documents with respect to the work to be performed by the Sub-Contractor so that the subcontracting thereof will not prejudice such rights, and shall allow to the Sub-Contractor, unless specifically provided otherwise in the Contractor agreement, the benefit of all rights, remedies and redress against the Contractor that the Contractor, by these Documents, has against the Owner.
 2. Where appropriate, the Contractor shall require each Sub- Contractor to enter into similar agreements with his Sub-Contractors. The Contractor shall make available to each proposed Sub-Contractor, prior to the execution of the Sub-trade contract, copies of the Contract Documents to which the Sub- Contractor will be bound by this Paragraph 14.C.1 and shall identify to the Sub-Contractor any terms and conditions of the proposed Sub-trade contract which may be at a variance with the Contract Documents. Each Sub-Contractor shall similarly make copies of such Documents available to his Sub-Contractors.

14. Separate Contractors

- A. The Contractor shall afford Galveston County's authorized Representative and other Contractors reasonable opportunity for the introduction and storage of their materials and equipment and the execution of their work, and shall connect and coordinate his Work with others under the general direction of Galveston County's authorized Representative.
- B. If any part of the Contractor's Work depends, for proper execution or results, upon the work of Galveston County's authorized Representative or any separate Contractor, the Contractor shall, prior to proceeding with the Work, promptly report to Galveston County's authorized Representative any apparent discrepancies of defects in such work that render it unsuitable for such proper execution and results. Failure of the Contractor so to report shall constitute an acceptance of the other Contractor's or Galveston County's authorized Representative's work as fit and proper to receive his Work, except as to latent defects

Galveston County Project 09-012a

- which may subsequently become apparent in such work by others.
- C. Copies of Drawings and Project Manual relating to these separate contracts will be available to the Contractor, upon request, for his information in carrying out the above provisions. The Contractor shall be held responsible for any damage or misfit resulting from his neglect to comply with the foregoing.
 - D. All Contractors on the project shall have equal rights on the premises for the performance of their work, but shall follow the sequence established by the progress schedule and/or instruction issued by Galveston County's authorized Representative.
 - E. If the Contractor notifies Galveston County's authorized Representative, in writing, that another contractor on this project is failing to coordinate his work with the Work of this contract, as directed, Galveston County's authorized Representative will promptly investigate the charge. If he finds it to be true, he will promptly issue such directions to the other contractor with respect thereto as the situation may require. Galveston County's authorized Representative or Owner shall not, however, be liable for any damages suffered by this Contractor by reason of the other contractor's failure to promptly comply with the directions so issued by Galveston County's authorized Representative or by reason of another contractor's default in performance; it being understood that Galveston County's authorized Representative does not guarantee the responsibility or continued efficiency of any contractor. Any costs caused by defective or ill-timed work shall be borne by the party responsible therefore.
 - F. Should the Contractor wrongfully cause damage to the work or property of the Owner, any separate Contractor or other Contractor, the Contractor shall, upon due notice, promptly attempt to settle with the Owner, the separate Contractor or other Contractor by agreement, or otherwise resolve the dispute. If such separate Contractor or other Contractor sues the Owner on account of any damage alleged to have been caused by the Contractor, the Owner shall notify the Contractor who shall defend such proceedings at the Contractor's expense, and if any judgment or award against the Owner arises therefrom, the Contractor shall pay or satisfy it and shall reimburse the Owner for all attorney's fees and court costs which the Owner has incurred.
 - G. Should the Contractor sustain any damage through any act or omission of any other contractor having a contract with the Owner for the performance of work upon the site or of work which may be necessary to be performed for the proper prosecution of the work to be performed hereunder, or through any act or omission of a subcontractor of such contractor, the Contractor shall have no claim against the Owner, Architect or Engineer, Galveston County's authorized Representative or the Owner's consultants for such damage, but shall have a right to recover such damage from the other contractor under the provision similar to the following provisions that have been or will be inserted in the contracts with such other contractors.
 - H. Should any other contractor having or who shall hereafter have a contract with the Owner for the performance of work upon the site sustain any damage through any act or omission of a Sub-Contractor of the Contractor, the Contractor agrees to reimburse such other contractor for all such damages and to indemnify and hold the Owner, Architect or Engineer and Galveston County's authorized Representative harmless from all claims.
 - I. The Contractor shall indemnify and hold the Owner, Architect or Engineer and Galveston County's authorized Representative harmless from any and all claims or judgments for damages and from costs and expenses to which the Owner and/or Galveston County's authorized Representative may be subjected or which either may suffer or incur by reason of the Contractor's failure to comply with the Galveston County's authorized Representative's directions promptly. If the Contractor installs any work prior to proper coordination, or in such manner as to cause interference with work of others, he shall arrange for removal of or arrange for necessary modifications to the work. Any such action is subject to the approval of Galveston County's authorized Representative and shall be at no additional cost.
 - J. The Contractor shall cooperate with the Owner, Architect or Engineer and Galveston County's authorized Representative and other Contractors working on this project in order to avoid interference, inconvenience or damage. To aid in avoiding conflicts, the Contractor, without additional charge, shall make all reasonable modifications in the work as may be directed by Galveston County's authorized Representative. In the event of the Contractor's operations causes any damage, interference, or inconvenience to work being carried out under any other Trade Contract, the Contractor shall restore, replace, rectify, or otherwise make good any damage to the satisfaction of Galveston County's authorized Representative or to the other Contractors. Should the responsible Contractor fail to comply with this provision, the work will be done by others at the expense of the responsible Contractor.
 - K. Contractor agrees that he has become familiar with the site, has reviewed the plans and Project Manual covering the work of his and other trades and thereby accepts responsibility for all necessary coordination

Galveston County Project 09-012a

of his Work with the work of other trades affected.

15. Governing Law and Venue

- A. The Contract shall be governed by the law of the place where the Project is located. Any action arising from or relating from this Contract shall be instituted in a court of competent jurisdiction in Galveston County, Texas.
- B. Contractor shall at all times observe and comply with all Federal, State and Local Laws, ordinances and regulations which in any manner effect the contract or the work.
- C. Contractor shall comply with all city, county, and state codes, laws, and ordinances in force at the time of award of Contract and applicable to such work.
- D. Contractor shall obtain, at Contractor's own expense such permits, certificates, and licenses as may be required in the performance of the specified work.
- E. Contractor shall be responsible for obtaining and furnishing all necessary permits and licenses, City, County, State or Federal as are required for the performance of this Contract.

16. Claims for Damages

- A. Should either party to the Trade Contract suffer injury or damage to person or property because of any act or omission of the other party or of any of his employees, agents or others for whose acts he is legally liable, claim shall be made, in writing, to such other party within a reasonable time after the first observance of such injury or damage.
- B. Notwithstanding the event of any claim, dispute, or other matter in question arising out of or relating to this Agreement or the breach thereof, the Contractor shall carry on the work and maintain the Substantial Completion Date and Galveston County's authorized Representative shall continue to make payments in accordance with this Agreement.
- C. All damage to the work from the action of the elements, or from any unforeseen circumstances in the prosecution of the work shall be repaired by the Contractor at his own costs.

17. Indemnification

The Contractor shall agree to assume all risks and responsibility for, and agrees to indemnify, defend, and save harmless, the County of Galveston, its elected and appointed officials and department heads, and its agents and employees from and against all claims, demands, suits, actions, recoveries, judgments, and costs and expenses including reasonable attorney's fees for the defense thereof in connection therewith on account of the loss of life, property or injury or damage to the person which shall arise from Contractor's operations under this Contract, its use of County facilities and/or equipment or from any other breach on the part of the Contractor, its employees, agents or any person(s) in or about the County's facilities with the expressed or implied consent of the County. Contractor shall pay any judgment with cost which may be obtained against Galveston County resulting from contractor's operations under this Contract.

Contractor agrees to indemnify and hold the County harmless from all claims of subcontractors, laborers incurred in the performance of this contract. Contractor shall furnish satisfactory evidence that all obligations of this nature herein above designated have been paid, discharged or waived. If Contractor fails to do so, then the County reserves the right to pay unpaid bills of which County has written notice direct and withhold from Contractor's unpaid compensation a sum of money reasonably sufficient to liquidate any and all such lawful claims.

18. Rights and Remedies

- A. The duties and obligations imposed by the Contract Documents and the rights and remedies available thereunder shall be in addition to and not a limitation of any duties, obligations, rights and remedies otherwise imposed or available by law.
- B. No action or failure to act by the Owner, Construction Manager, Architect or Engineer or Contractor shall constitute a waiver of any right or duty afforded any of them under the Contract Documents, nor shall any such action or failure to act constitute an approval of or acquiescence in any breach thereunder, except as may be specifically agreed in writing.

19. Tests

- A. If the Contract Documents, laws, ordinances, rules, regulations or order of any public authority having jurisdiction require any portion of the Work to be inspected, tested or approved, the Contractor shall give

Galveston County Project 09-012a

Galveston County's authorized Representative timely notice of its readiness so the Architect or Engineer and Galveston County's authorized Representative may observe such inspection, testing or approval. The Contractor shall bear all costs of such site visits, tests or approvals unless otherwise provided.

- B. If the Architect or Engineer or Galveston County's authorized Representative or Owner determines that any Work requires special inspection, testing or approval which Subparagraph 19.A does not include, he will, through Galveston County's authorized Representative, instruct the Contractor to order such special inspection, testing or approval and the Contractor shall give notice as in Subparagraph 19.A. If such special inspection or testing reveals a failure of the work to comply with the requirements of the Contract Documents, the Contractor shall bear all costs thereof, including compensation for the Architect or Engineer's and Galveston County's authorized Representative's additional services made necessary by such failure. If the Work complies, the Owner shall bear such costs and an appropriate Amendment shall be issued.
- C. Required certificates of inspection, testing or approval shall be secured by the Contractor and promptly delivered by him through Galveston County's authorized Representative to the Architect or Engineer.
- D. If the Architect or Engineer or Galveston County's authorized Representative is to observe the site visits, tests or approvals required by the Contract Documents, he will do so promptly and, where practicable, at the source of supply.
- E. Neither the observations of the Architect or Engineer or Galveston County's authorized Representative, in their Administration of the Construction Contract, nor site visits, test or approvals by persons other than the Contractor, shall relieve the Contractor from his obligation to perform the Work in accordance with the Contract Documents.
- F. The Contractor shall deliver test samples of any of the materials specified in any of the Sections of his Specifications to an independent testing laboratory selected and approved by the Owner and Construction Manager, if so required. This may apply to materials proposed for use, materials already delivered to the job, or materials already incorporated into the construction.
- G. The Contractor shall maintain a file of all test reports. At the completion of the project, these reports will be submitted as an Appendix to the Operations and Maintenance Manual described above.
- H. Any materials, which fail to meet the requirements of these Specifications, shall not be used whether or not previously approved by the Architect or Engineer. If they have been delivered to the job, they shall be removed. If they have already been incorporated into the construction, Galveston County's authorized Representative or the Architect or Engineer may order them removed, or, at the discretion of the Owner, through Galveston County's authorized Representative they may be permitted to remain in place providing the Contractor agrees to a proper deduction from the contract sum.
- I. The services of a testing and inspection engineer selected by the Owner and Architect or Engineer shall be provided and paid for by the Owner for the tests required in the paragraph 20.F unless specifically stated otherwise or due to deficient work.

20. Interest

- A. Payments due and unpaid under the Contract Documents shall bear interest in accordance with applicable law.

21. Time

- A. Definitions
 1. Unless otherwise provided, the Contract Time is the period of time allotted in the Contract Documents for the Substantial Completion of the Work as defined in Subparagraph (22.A.3) including authorized adjustments thereto.
 2. The date of commencement of the Work shall be the date of the Notice to proceed.
 3. The date of Substantial Completion of the Work, for each Contractor, or designated portion thereof is the Date certified by the Architect or Engineer when construction is sufficiently complete, in accordance with the Contract Documents, so the Owner can occupy or utilize the Work or designated portion for the use for which it is intended.
 4. The term day as used in the Contract Documents shall mean calendar day unless otherwise specifically designated.
- B. Progress and Completion
 1. With the Galveston County's authorized Representative's approval, the Contractor shall suspend any work that may be subject to damage by climatic conditions. Under such conditions, the

Galveston County Project 09-012a

Contractor shall take measures to protect his work and to minimize the impact on progress of the work.

C. Delays and Extension of Time

1. If the Contractor is delayed at anytime in the progress of the Work by any act or neglect of the Owner, Construction Manager, or the Architect or Engineer, or by any employee of either, or by any separate contractor employed by the Owner, or by changes ordered in the Work, or by labor disputes, fire, unusual delay in transportation, adverse weather conditions not reasonably anticipatable, unavoidable casualties or any causes beyond the Contractor's control, and without his fault or negligence, or by any other cause which Galveston County's authorized Representative determines may justify the delay, then the Contract Time shall be extended by Contract Amendment for such reasonable time as Galveston County's authorized Representative may determine.
2. Any claim for extension of time shall be made in writing to Galveston County's authorized Representative not more than ten (10) days after the commencement of the delay; otherwise, it shall be waived. Any claim for extension of time shall state the cause of the delay and the number of days extension requested. If the cause of the delay is continuing, only one claim is necessary, but the Contractor shall report the termination of the cause for the delay within ten (10) days after such termination; otherwise, any claim for extension of time based upon that cause shall be waived.
3. In the event of a delay attributable in part to the Contractor and in part to causes or parties for which the Contractor is not responsible, then provided the Contractor has given proper and timely notice hereunder, the delay shall be equitably apportioned among the parties causing the delay and the Contractor shall remain liable for the portion not so excused.
4. If no agreement is made stating the dates upon which interpretations shall be furnished, then no claim for delay shall be allowed on account of failure to furnish such interpretations until fifteen days after written request is made for them, and not then unless such claim is reasonable.
5. No claim for an increase in the Contract Sum for either acceleration or delay will be allowed for extensions of time pursuant to this Paragraph 22.C or for other changes in the Construction Schedules.
6. There are no Liquidated damages for this project.
7. The permitting of the Contractor or the surety on the performance bond to proceed to complete any work or any part of it after the date of completion or after the date to which the time for completion may have been extended, shall in no way operate as a waiver on the part of the Owner of any of its rights hereunder.
8. Neither the Owner nor the Architect or Engineer nor Galveston County's authorized Representative shall have liability to the Contractor or to any other Contractor or Sub-Contractor for delay, hindrance, or interference in the performance of the Work, however caused, except for delay or hindrance resulting from active interference of Owner or its representatives in such Contractor's execution of the Work, and except for delay or hindrance resulting from defective plans and specifications not reasonably discoverable by the Contractor prior to Contract award.
9. The Contractor shall be liable to the Owner for any other damages sustained as the result of the Contractor's refusal or failure to perform the Work, provided, however, that such refusal or failure is not the result of a justifiable delay as defined in Subparagraph 22.C.1.

22. Payments and Completion

A. Progress Payments

1. Contractor shall make application to Owner by submittal of Pay Request to Galveston County's authorized Representative for payment utilizing forms provided by Owner for that purpose. Contractor shall state the percentage or the limits of the work performed and request payment for the amount of acceptable work performed. Applications for payment shall be made monthly by Contractor on a regular date set by Galveston County's authorized Representative.
2. Upon approval of the request for payment by Galveston County's authorized Representative and Architect or Engineer the Owner shall then pay the Contractor on or before 30 days thereafter, the total amount of the request, less 5% of the amount thereof, which 5% shall be retained until final payments, and further less all previous payments, and further less all further sums that may be retained by the County under the terms of this agreement

Galveston County Project 09-012a

3. Upon the attainment of substantial completion, payment will be made so that the sum of all payments made under the contract equals Ninety Five Percent (95%) of the total contract amount
 4. Galveston County's authorized Representative may request As-Built Drawings, schedule updates, payrolls for all labor, and other data supporting payment to subcontractors and/or materials suppliers before processing the requisition..
 5. Except in case of bona fide disputes, or where the Contractor has some other justifiable reason for delay, the Contractor shall pay for all transportation and utility services not later than the end of the calendar month following that in which services are rendered and for all materials, tools and other expendable equipment to the extent of ninety five percent (95) of the cost thereof not later than the end of the calendar month following that in which such materials, tools and equipment are delivered at the site of the Project and in compliance with Texas Law. The Contractor shall pay to each of his Sub-Contractors, not later than the end of the calendar month in which each payment is made to the Contractor, the representative amount allowed the Contractor on account of the work performed by his trade subcontractors, to the extent of each Sub-Contractor's interest therein and in compliance with Texas Law. The Contractor shall, by an appropriate agreement with each Sub-Contractor, also require each Sub-Contractor to make payments to his suppliers and Sub-Contractors in a similar manner.
 6. Materials, equipment and associated components that are in compliance with the approved submittals and will be incorporated into the structure, may be taken into consideration in computing progress payments, provided the material is delivered on the project site, or is delivered to the Contractor and the material is properly stored in a warehouse, storage yard or similar suitable place as may be approved by Galveston County's authorized Representative. The Contractor shall remain responsible for all such stored materials.
 - a. Payment for materials, equipment and associated components stored on-site shall be 100% of a valid invoice less 5% retainage, indicating the unit quantity, description of the material or equipment and cost.
 - b. Payment for materials, equipment and associated components stored off-site shall be 100% percent of a valid invoice, less 5% retainage, indicating the unit quantity, description of the material or equipment and costs. Before such payment is made, the Contractor shall furnish Galveston County's authorized Representative with a certified statement giving the exact location of the materials or equipment, that such material or equipment is properly stored and protected, and that it will not be diverted for use or installation at a different project. The Contractor shall furnish Galveston County's authorized Representative properly executed bills of sale and a certificate of insurance coverage for the material upon which payment is being made.
 7. All material and work covered by payments made shall thereupon become the sole property of the Owner but Contractor shall remain responsible to protect same.
- B. Payments withheld
1. Galveston County's authorized Representative may decline to approve an Application for Payment if in his opinion the application is not adequately supported. If the Contractor and Galveston County's authorized Representative cannot agree on a revised amount, Galveston County's authorized Representative shall process the Application for the amount he deems appropriate. Galveston County's authorized Representative may also decline to approve any Applications for Payment or, because of subsequently discovered evidence or subsequent site visits, he may nullify in whole or in part any approval previously made to such extent as may be necessary in his opinion because of:
 - a. defective work not remedied;
 - b. third party claims filed or reasonable evidence indicating probable filing of such claims;
 - c. failure of the Contractor to make payments properly to Sub-Contractors or for labor, materials or equipment;
 - d. reasonable evidence that the Work cannot be completed for the unpaid balance of the Contract Sum;
 - e. damage to the Owner, or another contractor working at the Project;
 - f. reasonable evidence that the Work will not be completed within the Contract Time; or
 - g. persistent failure to carry out the Work in accordance with the Contract Documents.

Galveston County Project 09-012a

- h. no payment shall be made to the Contractor until certificates of insurance or other evidence of compliance by the Contractor with all the requirements of Article 30 have been filed with the Owner and Galveston County's authorized Representative. Further, no payments on the basis of work performed by a Sub-Contractor shall be paid until copies of all bonds required and any certificates of insurance required of the Sub-Contractors under Article 30 have been filed with the Owner and Construction Manager.
 - i. the filing of a claim against the Project, which claim, is caused by the act or inaction of the Contractor or his Sub-Contractors;
 - j. refusal to follow the Project Safety Program issued as a contract document or Contractors Safety Program;
 - k. failure to maintain record drawings as specified;
 - l. failure to comply with HUB requirements;
 - m. failure to comply with EEO Requirements;
 - n. failure to properly submit a response to an RFP (Request for Proposal) within thirty (30) days of receipt thereof.
2. When the above grounds in subparagraph 22.B.1 are removed, payment shall be made for amounts withheld because of them.
- C. Failure of Payment
- 1. If the Contractor is not paid and is approved for payment by Galveston County's authorized Representative and has become due and payable, then the Contractor may, upon seven additional days written notice to the Owner and Construction Manager, stop the Work until payment of the amount due has been received. The Contract Sum shall be increased by the amount of the Contractor's reasonable costs of shutdown, delay and startup, which shall be effected by appropriate Contract Amendment in accordance with Paragraph 27.C.
- D. Substantial Completion
- 1. On or about the end of the project, the Contractor shall perform the following in order to achieve Substantial Completion.
 - a. When in the opinion of the Contractor the work is substantially complete,.
 - b. The Contractor shall notify Galveston County's authorized Representative, in writing, that the work will be ready for review and test on a definite date.
 - c. Notice shall be given at least fifteen (15) days in advance of said date.
 - d. Galveston County's authorized Representative shall forward the notice to the Architect or Engineer and will attach his endorsement as to whether or not he concurs with the Contractor's statement that the work will be ready for review or test on the date given, but such endorsement shall not relieve the Contractor of his responsibility in the matter.
 - e. If the Architect or Engineer concurs that the Work will be ready for review or test on the date given, the Architect or Engineer and Galveston County's authorized Representative will make such review after Contractor submits a thorough list of items to be completed or corrected (Punch List).
 - f. The Contractor is required to furnish access for the substantial Completion review.
 - g. Contractor shall have all systems fully functional and operational for the review.
 - h. The Architect or Engineer/Engineer and Galveston County's authorized Representative will inspect the project utilizing the Contractor's prepared Punch List, noting completed or incomplete items, and prepare a supplemental list of items that have been omitted or incomplete items that were not previously noted. The Architect or Engineer, at his discretion, may attend and assist in the preparation of the Contractor's punch list.
 - i. Contractor completes corrections, and Architect or Engineer and Galveston County's authorized Representative re-inspect to establish Date of Substantial Completion.
Note: Any items remaining on date of Substantial Completion are appended to Certificate (AIA G-704).
 - j. Architect or Engineer may issue a Certificate of Substantial Completion at this point.
 - k. Certain warranties and insurances are dependent on the date of Substantial Completion from the above certification. No other date of Substantial Completion will be recognized by the Owner or Contractor.

Galveston County Project 09-012a

1. After the Certificate of Substantial Completion has been executed by all parties, it is returned to Galveston County's authorized Representative. Items on the appended Punch List are to be completed or corrected within the time limits established in the Certificate of Substantial Completion.
 2. The project may be considered substantially complete if the work has been completed to the point where the work can be utilized for the general purpose for which it was undertaken and has been certified by the Architect or Engineer.
 3. Progress payment request may not be submitted for more than 95% of the overall contract value at Substantial Completion.
- E. Final Completion and Payment
1. Contractor shall be responsible for and make good without extra charge any defects due to faults in labor or material on all parts of the Contract for one year (and longer where noted) after Substantial Completion of the Work as defined in Article 22 in the General Conditions.
 2. Property not in the Contract but damaged due to defects, shall be repaired or replaced by the Contractor without extra charge.
 3. When notified by the Owner or Architect or Engineer that a defect exists and there is a doubt that the defect might be normal maintenance or a result of lack of normal maintenance, the Owner will send a representative with the Contractor's representative to determine responsibility. Owner will not pay for such service calls if the defect is judged to be normal maintenance or a result of a lack of normal maintenance.
 4. Neither the Final Certificate of Payment or payment of same, nor provision in the Contract Documents shall relieve the Contractor of the responsibility for negligence or faulty materials or workmanship within the extent and period provided by law and upon written notice, he shall remedy any defects due thereto and pay all expenses for any damage to other Work resulting there from. This guarantee of Work shall not relieve the Contractor of obligations of any Work not according to Plans and Specifications regardless of time of discovery.
 5. No final payment will be considered until all deficiencies listed with the Certificate of Substantial Completion have been remedied.
 6. Contractor submits written notice to Galveston County's authorized Representative that work is ready for final review and acceptance, and shall specifically note each item on the Punch List as being complete or the status of any incomplete item.
 7. Notice shall be given at least fifteen (15) days in advance of said date.
 8. Galveston County's authorized Representative shall forward the notice to the Architect or Engineer and will attach his endorsement as to whether or not he concurs with the Contractor's statement that the work will be ready for final review or test on the date given, but such endorsement shall not relieve the Contractor of his responsibility in the matter.
 9. If the Architect or Engineer concurs that the Work will be ready for final review or test on the date given, the Architect or Engineer and Galveston County's authorized Representative will make such review with the Contractor and Owner.
 10. The Contractor is required to furnish access for the final review.
 11. Neither application for final payment nor for the remaining retained percentage shall be made until the Contractor submits to Galveston County's authorized Representative the following:
 - a. an affidavit that all payrolls, bills for materials and equipment, and other indebtedness connected with the Work for which the Owner or his property might in any way be responsible, have been paid or otherwise satisfied,
 - b. consent of surety, if any, to final payment,
 - c. properly executed " General Release and Claim Waiver and General Guarantee" on forms acceptable to Galveston County's authorized Representative,
 - d. specified warranties and guarantees,
 - e. other data establishing payment or satisfaction of all such obligations, such as receipts, releases and waivers of bond claims arising out of the Contract, to the extent and in such form as may be designated by the Owner. If any Sub-Contractor refuses to furnish a release or waiver required by the Owner the Contractor may furnish a bond satisfactory to the Owner to indemnify them against any such claim. If any such claim remains unsatisfied after all payments are made, the Contractor shall refund to the Owner or Galveston County's authorized Representative all moneys that the latter may

Galveston County Project 09-012a

- be compelled to pay in discharging such claim, including all costs and reasonable attorneys' fees.
12. Contractor submits Final Application for Payment and a Certificate of Compliance, which indicates the following:
 - a. All Permit Numbers
 - b. Utility Release Dates
 - c. The building has been duly inspected and found to comply with all code requirements and ordinances.
 - d. A Certificate of Occupancy has been issued.
 - e. Architect and Engineer (with Owner's authorized Representative) make final inspection
 - f. Contractor submits additional final items:
 - g. Consent of Surety to Final Payment (AIA G-707)
 - h. Contractor's Affidavit of Payment of Debts and Claims (AIA G-706)
 - i. Contractor's Affidavit of Release of Liens (AIA G-706A with contractors, subcontractors and suppliers separate releases)
 - j. Contractor's Guarantee
 - k. Subcontractors' Guarantees.
 - l. Maintenance and Instruction Manuals. All manuals will contain an index listing the information submitted. The index sections will be divided and identified by tabbing each section as listed in the index.
 - m. Record Drawings (reproducible sepias)
 - n. Final List of Subcontractors (AIA G-805)
 - o. Affidavits from Contractor, Subcontractors, and suppliers stating that no asbestos products have been installed in this project.
 - p. Furnish written warranties to the Owner including specific items in each product warranty stipulated for individual sections.
 - q. Documents identified as "affidavit" must be notarized.
 - r. Contractor has documented the turnover of spare stock of materials, spare parts accessories and special tools to the Owner through Galveston County's authorized Representative,
 - s. Final Cleaning:
 - a. The work area shall be thoroughly cleaned inside and outside. Cleaning includes removal of smudges, marks, stains, fingerprints, soil, dirt, spots, dust, lint, and other foreign materials from finished and exposed surfaces.
 - b. Remove all temporary facilities.
 13. If the Work is found acceptable under the Contract Documents and the Contract fully performed, and Galveston County's authorized Representative, upon receipt of a correct final Application for Payment, recommends to the Owner that such payment be made.
 14. The making of final payment shall constitute a waiver of all claims by the Owner or Galveston County's authorized Representative except those arising from:
 - a. unsettled claims;
 - b. faulty or defective Work appearing after Substantial Completion;
 - c. failure of the Work to comply with the requirements of the Contract Documents; or
 - d. terms of any special warranties required by the Contract Documents.
 15. The acceptance by the Contractor of the final payment shall be, and operate as, a release to the Owner and to Galveston County's authorized Representative of all claims and of all liability to the Contractor for all things done or furnished in connection with this Trade Contract..
 16. Final Payment to Contractor **does not include** payment of **retainage**. Payment of **retainage will be made after project completion and in accordance** with Article 3 of Agreement between Galveston County and Contractor.
23. **Protection of Persons and Property**
- A. Safety Precautions and Programs
 1. The Contractor expressly undertakes, both directly and through his Sub-Contractors to take every precaution at all times for the protection of persons, including employees and property. The Contractor shall be responsible for initiating, maintaining and supervising all safety precautions and programs in connection with the Work.
 2. If the Contractor fails to maintain the safety precautions required by law or directed by Galveston County's authorized Representative, Galveston County's authorized Representative may take such steps as necessary and charge the Contractor therefore.
 3. The failure of Galveston County's authorized Representative to take any such action shall not relieve the Contractor of his obligations in Subparagraph 24.A.1.
 - B. Safety of Persons and Property

Galveston County Project 09-012a

1. The Contractor shall submit his safety program to Galveston County's authorized Representative prior to mobilizing to the job, and shall be responsible for the safety, efficiency and adequacy of his plant, appliances and methods and for any damage, which might result from failure or improper construction, maintenance, or operation. The Contractor shall provide a safety report to Galveston County's authorized Representative on a weekly basis.
2. The Contractor shall take all reasonable precautions for the safety of, and shall provide all reasonable protection to prevent damage, injury or loss to:
 - a. all employees on the work and all other persons who may be affected thereby;
 - b. all the Work and all materials and equipment to be incorporated therein, whether in storage on or off the site, under the care, custody or control of the Contractor or any of his Sub-Contractors;
 - c. other property at the site or adjacent thereto, including trees, shrubs, lawns, walks, pavements, roadways, structures and utilities not designated for removal, relocation or replacement in the course of construction.
3. Contractor shall not permit any construction technique or activity, which decreases building security or safety. Contractors shall cooperate fully with the Galveston County's authorized Representative's and Owner's requirements regarding security and safety of the building.
4. The Contractor shall give all notices and comply with all applicable laws, ordinances, rules, regulations and lawful orders of any public authority bearing on the safety of persons or property or their protection from damage, injury or loss.
5. The Contractor shall provide, erect, maintain, dismantle and remove, as required by existing conditions and progress of the Work, all reasonable safeguards for safety and protection, including posting danger signs and other warnings against hazards, promulgating safety regulations and notifying the Owners and users of adjacent utilities to the work. He shall protect the Owner's property from injury or loss arising in connection with this Contract. He shall adequately protect adjacent property as provided by law and the Contract Documents. He shall provide and maintain all passageways, guard fences, light and other facilities for protection required by public authority, local conditions, or any of the Contract Documents. At no time remove, alter or render ineffective any barricades, railings or cover on the project without written permission of Galveston County's authorized Representative. Where these safety devices are to be turned over to others, upon completion of the work, the devices shall be repaired or replaced so that they meet the required standards prior to turnover.
6. When the use or storage of explosives or other hazardous materials or equipment is necessary for the execution of the Work, the Contractor shall exercise the utmost care and shall carry on such activities under the supervision of properly qualified personnel. Fuel for cutting and burning torches shall be stored in locations and protected as directed by Galveston County's authorized Representative. No volatile liquids shall be used for cleaning agents or as fuels for motorized equipment or tools within a building except with the express approval of Galveston County's authorized Representative. Bulk storage of volatile liquids shall be outside the building at locations directed by Galveston County's authorized Representative and only so much volatile liquid shall be allowed within the building at any given time.
7. The Contractor shall promptly remedy all damage or loss (other than damage or loss insured under Paragraph 26.B to any property referred to in Clauses 24.B.2.b and 24.B.2.c caused in whole or in part by the Contractor, his Sub-Contractors, or anyone directly or indirectly employed by any of them, or by anyone for whose acts any of them may be liable and for which the Contractor is responsible under Clauses 24.B.2.b and 24.B.2.c except damage or loss attributable to the acts or omissions of the Owner or Architect or Engineer or anyone directly or indirectly employed by either of them or by anyone for whose acts either of them may be liable, and not attributable to the fault or negligence of the Contractor are in addition to his obligations under Article 5 in the Trade Contract.
8. The Contractor shall take all precautions required to prevent fires as a result of his operations. Where flame cutting torches, blow torches, or welding tools are required to be used within an existing building, their use shall be as approved by Galveston County's authorized Representative at the site. When welding tools or torches of any type are in use, the Contractor shall have available, in the immediate vicinity of the work, a fire extinguisher of the CO2 type. The fire extinguisher shall be provided and maintained by the Contractor.

Galveston County Project 09-012a

9. The Contractor shall advise Galveston County's authorized Representative, in writing, of all unusual flammable or toxic materials which the Contractor plans to store and use on site.
10. Shielding or similar precautions will be taken adjacent to welding operations
11. The Contractor shall designate a responsible member of his organization at the site whose duty shall be the prevention of accidents. This person shall be the Contractor's superintendent unless otherwise designated by the Contractor in writing to Galveston County's authorized Representative, and shall attend all project safety meetings scheduled by Galveston County's authorized Representative.
12. Every employee will be dressed for the work he performs. Minimum dress will consist of long pants, tee shirt, hardhat, safety glasses and work shoes. Shorts, cut-offs, "tank-top" shirts or soft-toed shoes will not be permitted.
13. Each Contractor shall, in a readily visible manner, identify all of his tools, equipment and similar materials, either by paint color or label. The Contractor shall provide his employees with a hard hat bearing his first initial, last name, and his Company name. This information shall be clearly visible at all times.
14. The Contractor shall not load or permit any part of the Work to be loaded so as to endanger its safety.
15. Weather protection shall be supplied by the Contractor and shall include any enclosure, supplemental heating, and furnishing and *any* other features (insulation, etc.) for meeting conditions required by Galveston County's authorized Representative or by the Project Manual relative to the Contractor's work.

24. Emergencies

- A. In an emergency affecting the safety or life of individuals, or of the Work, or of adjoining property, the Contractor, without special instruction or authorization from the Owner or Galveston County's authorized Representative or Architect or Engineer, shall act, at his discretion, to prevent such threatened loss or injury. Also, should he, to prevent threatened loss or injury, be instructed or authorized to act by the Owner or Galveston County's authorized Representative or Architect or Engineer he shall so act, without appeal. Any additional compensation or extension of time claimed by the Contractor on account of any emergency work shall be determined as provided by Article 27 - Changes in Work.

25. Insurance

- A. Contractor shall purchase from and maintain in a company lawfully authorized to do business in the State of Texas and which carry a Best's rating of A-VII or higher such insurance as will protect the Contractor from claims set forth below which may arise out of or result from the Contractor's operations under this Agreement and for which the Contractor may be legally liable.
 1. claims under workers compensation, disability benefit and other similar employee benefit acts which are applicable to the operations to be performed;
 2. claims for damages because of bodily injury, occupational sickness or disease, or death of the Contractor's employees or ;
 3. claims for damages because of bodily injury, sickness or disease, or death of any person other than the Contractor's employees;
 4. claims for damages insured by usual personal injury liability coverage which are sustained (1) by a person as a result of an offense directly or indirectly related to employment of such person by the Contractor, or (2) by any other person;
 5. claims for damages, other than to the Work itself, because of injury to or destruction of tangible property, including loss of use resulting therefrom;
 6. claims for damages because of bodily injury, death or property damage arising out of ownership, maintenance or use of a motor vehicle;
 7. claims involving contractual liability insurance applicable to the Contractor's obligations under
- B. Contractors Liability Insurance
 1. Contractor shall keep in full force and effect, a policy of public liability and property damage insurance issued by a casualty company authorized to do business in the State of Texas, and in standard form approved by the Board of Insurance Commissioners' of the State of Texas, with coverage provision insuring the public from any loss or damage that may arise to any person or property by reason of services rendered by successful Proposer and providing that the amount by reason of services limits of not less than the following sums:
 - a. Workmen's Compensation

Galveston County Project 09-012a

- 1) State Statutory limits
- b. Comprehensive General Liability (including Premises – Operations; Independent Contractor’s Protective; Products and Completed Operations; Broad Form Property Damage
 - 1) Bodily Injury
 - i. \$100,000.00 each person, each occurrence
 - ii. \$300,000.00 Aggregate, each occurrence
 - c. Property Damage including loss of use
 - 1) \$100,000.00 Each occurrence
 - d. Products and Completed Operations to be maintained for one (1) year after Final Payment
 - e. Property Damage Liability Insurance will provide X, C or U coverage as applicable
- C. Contractual Liability
 1. Bodily Injury
 - a. \$100,000.00 Each Person
 - b. \$300,000.00 Each occurrence
 2. Property Damage
 - a. \$100,000.00 Each occurrence
- D. Personal injury, with Employment Exclusion deleted:
 - a. \$100,000.00 Each occurrence
- E. Comprehensive Automobile Liability (including owned, non-owned and hired motor vehicles):
 1. Bodily Injury
 - a. \$100,000.00 Each Person
 - b. \$300,000.00 Each occurrence
 2. Property Damage
 - a. \$100,000.00 Each occurrence
- F. Umbrella Liability Coverage:
 1. \$1,000,000.00 to provide excess liability coverages required above.
- G. Professional Liability Coverage:
 2. \$1,000,000.00 to Abatement and Associated work or minimum State law.
- H. Galveston County, Construction Manager, and Architect or Engineer shall be named as “additional insured” on such policies as are specified above and shall be notified of any changes to the policy during the contractual period.
- I. The above requirements do not establish limits of Contractor’s liability.
- J. Such insurance is to be provided at the sole cost of Contractor.
- K. All policies of insurance shall waive all rights of subrogation against Galveston County, its officers, employees and agents.
- L. Galveston County reserves the right to require additional insurance should it be deemed necessary.
- M. This insurance required by Subparagraph 26.B-G shall be written for not less than limits of liability listed or required by law, whichever is greater.
- N. The insurance required by Subparagraph 26.B-G shall include premises operations (including explosion, collapse and underground coverage), elevators, independent contractors, products and/or completed operations, and contractual liability insurance (on a "blanket basis" designating all written contracts), all including broad form property damage coverage. Liability insurance may be arranged under Commercial General Liability policies for the full limits required or by a combination of underlying policies for lesser limits with the remaining limits provided by an Excess or Umbrella Liability Policy.
- O. The insurance required by Subparagraph 26.B-G shall include contractual liability insurance applicable to the Contractor's obligations under Article 5 in the Trade Contract
- P. Property Insurance
 1. Unless otherwise provided, the Owner will purchase and maintain property insurance upon the entire Work at the site to the full insurable value thereof. This insurance shall include the interests of the Owner, Galveston County's authorized Representative, the Contractors and Sub-Contractor in the Work and shall insure against the perils of fire and extended coverage, and shall include "all risk" insurance for physical loss or damage. This coverage carries a deductible per occurrence, which will be paid by the Contractor or Sub-Contractor responsible for each loss. This insurance coverage does not cover the Contractor's or Sub-Contractor's tools and equipment.
 2. The Owner will effect and maintain such boiler and machinery insurance as may be necessary

Galveston County Project 09-012a

- and/or required by law. This insurance shall include the interest of the Owner, Galveston County's authorized Representative, the Contractors, and Sub-Contractors in the Work.
3. Any loss insured under Paragraph 26.B-G is to be adjusted with the Owner and made payable to the Owner as trustees for the insured's, as their interests may appear, subject to the requirements of any applicable mortgage clause.
 4. The Owner, Galveston County's authorized Representative, the Architect or Engineer, the Contractors, and the Sub-Contractors waive all rights against each other and any other contractor or subcontractor engaged in the Project for damages caused by fire or other perils to the extent covered by insurance provided under Paragraph 30.2, or any other property or consequential loss insurance applicable to the project, equipment used in the Project, or adjacent structures, except such rights as they may have to the proceeds of such insurance. If any policy of insurance requires an endorsement to maintain coverage with such waivers, the owner of such policy will cause the policy to be so endorsed. The Owner will require, by appropriate agreement, written where legally required for validity, similar waivers in favor of the Contractors and Sub-Contractors by any separate contractor and his subcontractors.
 5. The Owner shall deposit in a separate account any money received as trustees, and shall distribute it in accordance with such agreement as the parties in interest may reach.
 6. The Owner as trustees shall have power to adjust and settle any loss with the insurers.
 7. If the Owner finds it necessary to occupy or use a portion or portions of the Work prior to Substantial Completion thereof, such occupancy shall not commence prior to a time mutually agreed to by the Owner and Galveston County's authorized Representative and to which the insurance company or companies providing the property insurance have consented by endorsements to the policy or policies. This insurance shall not be cancelled or lapsed on account of such partial occupancy.

26. Changes in the Work

A. Change Authorization/Contract Amendments

1. Changes in the Work may be accomplished after execution of the contract, and without invalidating the Contract, by Change Order, or order for a minor change in the work, subject to the limitations stated in this Article 27 and elsewhere in the contract Documents. A Change Authorization is a written order to the Contractor signed by Owner, in the form of an Agreement Amendment issued after the execution of the Contract, authorizing a Change in the Work or an adjustment in the Contract Sum and/or the Contract Time. The Contract Sum and the Contract Time may be changed only by Written Amendment. An Amendment signed by the Contractor indicates his agreement therewith, including the adjustment in the Contract Sum and/or the Contract Time. Contractor agrees that the dollar amount and time extensions, as applicable, in each Change Order constitutes full compensation to the Contractor for all costs, expenses and damages to the Contractor, whether direct, consequential or otherwise, in anyway incidental to or arising out of, or resulting, directly or indirectly from the work performed or modified by the Contractor. Amendments not formally rejected within ten (10) days after receipt shall be deemed accepted.
2. If unit prices are stated in the Contract Documents or subsequently agreed upon, and if the quantities originally contemplated are so changed in a proposed Change In The Work that application of the agreed unit prices to the quantities of work proposed will cause substantial inequity to the Owner or the Contractor, the applicable unit prices shall be equitably adjusted.

B. Concealed Conditions

1. Should concealed conditions be encountered in the performance of the Work below the surface of the ground or should concealed or unknown conditions in an existing structure be at variance with the conditions indicated by the Contract Documents, or should unknown physical conditions in an existing structure of an unusual nature, differing materially from those ordinarily encountered and generally recognized as inherent in work of the character provided for in this Contract, be encountered, the Contractor must report the conditions to Galveston County's authorized Representative before the conditions are disturbed. Galveston County's authorized Representative shall thereupon notify the Architect or Engineer.
 - a. Upon such notices, or upon his own observation of such conditions, the Architect or Engineer shall promptly make such changes in the Drawings and Project Manual as he

Galveston County Project 09-012a

finds necessary to conform to the different conditions. Any change in the cost of the work or the time needed for completion resulting from concealed conditions shall be determined in accordance with Article 8 in the Trade Contract provided a notice there of is made within ten (10) days after the first observance of the conditions.

C. Claims for Additional Cost

1. A change in the work may be initiated in one of two ways:
 - a. A "Request for Proposal" Form (RFP) from Galveston County's authorized Representative to the Contractor describing the revision to the work desired. Usually, it is accompanied by revised drawings, sketches or other data.
 - b. Formal notification from the Contractor documenting a "concealed condition" requesting investigation by Galveston County's authorized Representative and Architect or Engineer which causes changes in the Drawings and Project Manual (and a subsequent Request for Proposal on the revised documents).
2. If the Contractor claims that any instructions given to him by Galveston County's authorized Representative, by drawings or otherwise, involve extra work not covered by the Contract, he shall give Galveston County's authorized Representative written notice of the additional cost within ten (10) days after the receipt of such instructions and before proceeding to execute the work, except in emergencies endangering life or property, in which case the Contractor shall proceed in accordance with Article 27. Should it not be clear to the Contractor that a change will involve extra work, written notice given within five (5) days that the change may involve extra work will be considered sufficient notice. If it is later determined that the work involved in such instruction shall be recognized as an extra, the amounts of additional compensation to be paid therefore, should be determined in accordance with Article 8 in the Trade Contract. Failure to respond as noted shall waive the Contractor's claim for additional compensation.
3. Timely submittal (Return) of Requests for Proposal is mandatory. RFP's shall be answered and returned within ten (10) days of receipt. Failing to return RFP's within thirty (30) days may constitute basis for withholding progress payments.
4. Galveston County's authorized Representative will inform the Contractors, and the Contractor will inform Galveston County's authorized Representative when either party recognizes a proposed change (RFP) may affect the progress of the work as scheduled.
5. Any claim for damages of any character, delays for which the Owner is liable under the Contract Documents, extra work or extra compensation of any other nature, shall be waived unless notice thereof is given to Galveston County's authorized Representative, in writing, within 10 days after the occurrence of the event which is relied upon to justify the claim or within such time as the event should have reasonably been discovered by the Contractor, and in any event, before extra cost is incurred.

D. Minor Changes in the Work

1. The Architect or Engineer will have authority to order through Galveston County's authorized Representative minor changes in the Work not involving an adjustment in the Contract Sum or an extension of the Contract Time and not inconsistent with the intent of the Contract Documents. Such changes shall be effected by written order and such changes shall be binding on the Owner, Galveston County's authorized Representative, and the Contractor. The Contractor shall carry out such written orders promptly.

27. Uncovering and Corrections of Work

A. Uncovering of Work

1. If any portion of the Work should be covered contrary to the request of Galveston County's authorized Representative or Architect or Engineer, or to requirements specifically expressed in the Contract Documents, it must, if required in writing by Galveston County's authorized Representative, be uncovered for their observation and replaced, at the Contractor's expense.
2. If any other portion of the Work has been covered which neither Galveston County's authorized Representative nor the Architect or Engineer has specifically requested to observe prior to being covered, the Architect or Engineer or Galveston County's authorized Representative may request to see such Work and it shall be uncovered by the Contractor. If such Work be found in accordance with the Contract Documents, the cost of uncovering and replacement shall, by appropriate Change Order, be charged to the Owner or Construction Manager, as the case may

Galveston County Project 09-012a

be. If such Work were found not in accordance with the Contract Documents, the Contractor shall pay such costs unless it is found that this condition was caused by a separate Contractor employed as provided in Article 15, and in that event, the separate Contractor shall be responsible for the payment of such costs.

B. Correction of Work

1. The Contractor shall promptly correct all Work rejected by the Architect or Engineer or Galveston County's authorized Representative as defective or as failing to conform to the Contract Documents whether observed before or after Substantial Completion and whether or not fabricated, installed complete. The Contractor shall bear all costs of correcting such rejected Work, including compensation for the Architect or Engineer's and/or Galveston County's authorized Representative's additional services made necessary thereby.
2. If, within one year after the Date of Substantial Completion of Work or designated portion thereof, or within one year after acceptance by the Owner of designated equipment or within such longer period of time as may be prescribed by law or by the terms of any applicable special warranty required by the Contract Documents, the Contractor is notified of defective work he shall correct it promptly. This obligation shall survive the termination of the Contract. The Owner or Galveston County's authorized Representative shall give such notice promptly after discovery of the condition.
3. The Contractor shall remove from the site all portions of the Work which are defective or nonconforming and which have not been corrected under Subparagraphs 8.1, 28.B.1 and 28.B.2, unless removal has been waived by the Owner.
4. If the Contractor fails to correct defective or nonconforming Work as provided in Subparagraphs 8.1, 28.B.1 and 28.B.2, the Owner or Galveston County's authorized Representative may correct it in accordance with Article 9 in the Trade Contract.
5. If the Contractor does not proceed with the correction of such defective or nonconforming work within a reasonable time fixed by written notice from Galveston County's authorized Representative, the Owner or Galveston County's authorized Representative may remove it and may store the materials or equipment at the expense of the Contractor. If the Contractor does not pay the cost of such removal and storage within ten days thereafter, the Owner or Galveston County's authorized Representative may upon ten additional days' written notice sell such Work at auction or at private sale and shall account for the net proceeds thereof, after deducting all the costs that should have been borne by the Contractor, including compensation for the Galveston County's authorized Representative's additional services made necessary thereby. If such proceeds of sale do not cover all costs, which the Contractor should have borne, the difference shall be charged to the Contractor and an appropriate Contract Amendment shall be issued. If the payments then or thereafter due the Contractor are not sufficient to cover such amount, the Contractor shall pay the difference to the Owner or Galveston County's authorized Representative.
6. The Contractor shall bear the cost of making good all work of other contractors destroyed or damaged by such removal or correction.
7. Nothing contained in this Article shall be construed to establish a period of limitation with respect to any other obligation, which the Contractor might have under the Contract Documents. The establishment of the time period of one year after the Date of Substantial Completion or such longer period of time as may be prescribed by law or by the terms of any warranty required by the Contract Documents, relates only to the specific obligation of the Contractor to correct the Work, and has no relationship to the time within which his obligation to comply with the Contract Documents may be sought to be enforced, nor to the time within which proceedings may be commenced to establish the Contractor's liability with respect to his obligations other than specifically to correct the Work.

28. Termination of the Contract

A. Termination by the Contractor

1. If the Work is stopped, under an order of any court or other public authority having jurisdiction, for a period of three (3) months, through no fault of the Contractor or a Sub-Contractor or their agents or employees or any other persons performing any of the Work under a contract with the Contractor, or if Galveston County should fail to pay the Contractor in accordance with Article 3

Galveston County Project 09-012a

of the Trade contract, the Contractor may, upon thirty (30) additional days written notice terminate the contract and recover from the Owner payment for all Work executed and for any proven loss sustained upon any materials, equipment, tools, construction equipment and machinery.

B. Termination by the Owner

1. If the Contractor is adjudged a bankrupt, or if he makes a general assignment for the benefit of his creditors, or if a receiver is appointed on account of his insolvency, or if he persistently or repeatedly refuses or fails, except in cases for which extension of time is provided, to supply enough properly skilled workmen or proper materials, or if he fails to make prompt payment to Sub-Contractors or suppliers, or persistently disregards laws, ordinances, rules, regulations or orders of any public authority having jurisdiction, or otherwise is guilty of a substantial violation of a provision of the Contract Documents, then the Owner without prejudice to any right or remedy and after giving the Contractor and his surety, if any, ten days written notice, terminate the Contract and take possession of the site and of all materials, equipment, tools, construction equipment and machinery thereon owned by the Contractor and may finish the work by whatever method he may deem expedient. In such case, the Contractor shall not be entitled to receive any further payment until the Work is finished.
2. If the unpaid balance of the Contract Sum exceeds the costs of finishing the Work, including compensation for the Architect or Engineer or Galveston County's authorized Representative's additional services made necessary thereby, such excess shall be paid to the Contractor. If such costs exceed the unpaid balance, the Contractor shall pay the difference to the Owner.

C. Termination for Convenience

1. The Owner reserves the right, for its convenience, to terminate the Work of the Contractor(s), in whole or in part, at any time by providing written or telegraphic notice to the Contractor stating the extent and effective date of such termination; whereupon such Contractor(s) shall: (i) stop all work and place no further orders or subcontracts for materials, services, equipment or supplies, except as may be necessary to complete portions of the Work not terminated; (ii) terminate work orders, purchase orders and subcontracts outstanding to the extent that they relate to the terminated portion of the Work; (iii) take any action necessary to protect property in Contractor's possession in which the Owner has or may acquire an interest; (iv) complete performance of the un-terminated portion of the Work; and (v) take any other action toward termination of the Work which Galveston County's authorized Representative may direct.
2. In the event that all or a portion of the Work of the Contractor(s) is terminated pursuant to Subparagraph 29.C.1 Contractor(s) shall be entitled to payment of those costs relating to the terminated portion of the Work as hereinafter defined. The Owner shall thereafter pay to the Contractor(s), subject to the limitations herein set forth, the sum of the following costs which represent the respective interest of the Contractor(s) to the terminated portion of the Work:
 - a. Portion of the Contract Sum related to the work completed by the Contractor immediately prior to Notice of Termination.
 - b. Expenses incurred or for which the Contractor is liable as the result of termination by Contractor of respective work orders, purchase orders or subcontracts related to the Notice of Termination including overhead and profit or completed work.
 - c. No payment shall be made for work not actually performed. Deductions will be made by Owner for amounts previously paid to Contractor and for any amounts which may be due Owner, or which Owner may offset or withhold by the terms hereof. The total amount of all payments to Contractor shall not exceed in any event, the proportion of the total Contract Sum that the Work actually performed (including materials delivered to the project site minus credits for returned goods or cancelled orders) at the date of termination bears to the entire Work to be performed hereunder.
 - d. After receipt of a Notice of Termination, Contractor shall submit to Galveston County's authorized Representative its written termination claim in the form and with the certification which the Owner or Galveston County's authorized Representative may require. Such claims shall be submitted promptly, but in no event more than ninety (90) days after the effective date of termination.

Galveston County Project 09-012a

A. General

1. Galveston County's authorized Representative will provide temporary toilets, excluding Contractor's trailer hookup.
2. Galveston County's authorized Representative will provide temporary fire safety equipment for general use. Each Contractor shall provide their own fire extinguishers for their trailers, and for use, as required when cutting and burning are performed.
3. Galveston County's authorized Representative will provide rubbish containers and rubbish disposal service unless noted otherwise in the Proposal Form. The Contractor must not use these containers for the disposal of earth, surplus or slop concrete, hazardous materials, and/or steel stock. Each Contractor must dispose of these elements at his own expense.
4. For further description and location of temporary services and system, refer to the Site Utilization Plan and the following paragraphs. Each Contractor shall be responsible for furnishing, installing or otherwise providing any or all of the following temporary facilities, structures or services as they may be necessary or required for or during, performance of the work of his Contract
 - a) Temporary field office facilities complete, including all furniture, heat, cooling, lighting, telephone, plumbing and toilet fixtures as he may require for his exclusive use. (Site location and number are subject to approval of Galveston County's authorized Representative).
 - b) Temporary storage facilities, sheds or buildings as may be required for the proper protection or storage of materials and/or equipment. (Site location and number are subject to approval of Construction Manager).
 - c) Temporary extension from, and hookup to, all temporary utilities which have been provided to a common point for use by the Contractors during construction.
 - d) Maintenance, cleanup and removal of all temporary facilities provided by the Contractor for his exclusive use.
 - e) Furnishing, erection, maintenance and removal of all temporary hoists and scaffolding as may be required by the Contractor for the performance of the work of his Contract.
 - f) Temporary drainage and dewatering measures including all pumping, drainage, erosion control or other work required to protect the work of the Contractor while in progress.
 - g) All temporary facilities, structures, services or items of work specifically required or defined in the Scope of Work of the Contract (Proposal Package) or otherwise required by the Contract Documents for his work.
 - h) Distribution of drinking water for his construction personnel.
 - i) At the end of the day's work, all work subject to damage by adverse weather conditions shall be covered or otherwise protected as required. Weather protection shall be adequate to permit each Contractor to work on a continuous basis without shutdown due to temperature or weather conditions as far as possible.
 - j) No temporary service shall be removed or disconnected until the new parts have been installed to replace them, properly connected and ready for use. The changing over from temporary to permanent work shall be done expeditiously, and if possible so that no part of the building or premises shall be without adequate service. If this is not possible, the procedure must be planned and submitted to Galveston County's authorized Representative for approval.

B. Temporary Electric System

1. Electric power for use in temporary trailers shall be available to the Contractor from a central location in the trailer area. The Contractor shall furnish any required extensions from this location at his own expense.
2. Electric service and distribution. The central service will be installed from the Utility Company's service point to the central distribution point on-site. Distribution from this point to the central connection point in the trailer area will be installed including any transformers, main disconnected switch or switches, any metering, supports, protective enclosure and grounding
 - a. Service will terminate in a panel board equipped with circuit breakers. Service characteristics available will be 120/208 volts, three phase, 4 wire web, unless otherwise specified. Total capacity to be shared shall be 400 amps. Use of electricity for basic heating of trailers will not be allowed

Galveston County Project 09-012a

- b. The distribution will be extended to the designated distribution points within the building. These distribution locations will provide:
 - 1. Panel board for breakers for lighting and hand tool circuits throughout the area served.
 - 2. Panel board and breakers for twenty (20) 20 amp circuits for connection of bench tools, such as, pipe threaders, etc.
 - c. The distribution will be extended upward to other floors of the building as indicated.
 - d. As the work progresses, structure, and decks are constructed, the lighting/hand tool circuits will be installed throughout the building according to the following criteria
 - e. Temporary lighting shall be installed in all areas and rooms, including all platforms, levels and stairways but excluding crawl spaces, duct and riser shafts. Temporary lighting shall be a minimum of 1/4 watt per square foot. For all areas 3,200 square feet or less, 100-watt lamps spaced approximately at 20 foot centers shall be used. Each room or enclosed area shall have, at least, one lighting and one tool outlet. Where 100 watt lights are used, the outlets shall consist of double weatherproof sockets. One (1) socket shall be used for the 100-watt lamp and the other socket shall be used for portable power tools.
 - f. Any temporary lighting required beyond the foregoing shall be provided by the party requiring the same and the work will be paid for by the Contractor.
 - g. Any extension cords will be provided by the Contractor.
 - h. Connecting and disconnecting Contractor tools and equipment to (and from) the above distribution system will be performed by qualified personnel, ALL grounding as required by the National Electrical Code, OSHA or any and all local codes, including approved ground fault interrupters shall be furnished and installed at the Contractors expense.
 - i. All contractors must share the system provided and average usage is anticipated. Any contractor anticipating fabrication area or operations must coordinate his needs through Galveston County's authorized Representative. If additional distribution is required and available at the control service, it will be provided at the Contractor's expense.
- 3. Operations and Maintenance
 - a. The system will be operated during normal work week, defined as five (5) days, including 1/2 hour before regular working hours and 1/2 hour after regular working hours for every trade.
 - b. Maintenance of the electrical service beyond the duration defined above will be at the expense of the Contractor requesting the service. Charges for maintenance of the services will be made from the Operating Contractor to the Contractor and will not involve (nor occur cost to) Galveston County's authorized Representative or Owner.
 - 4. Relocation to allow construction to proceed and removal when permanent power is available will be coordinated with Galveston County's authorized Representative as part of the maintenance service.
 - 5. The Electrical Contractor may be requested in a Proposal Package to include part or all of the above described temporary service and distribution and/or maintenance. (Review Scope of Work carefully).
 - 6. Payment for Electrical Energy
 - a. The Owner will pay for the cost of all energy consumed by all trades during the construction
- C. Temporary heating
- 1. Construction Heating
 - 2. Each Contractor shall be responsible for providing his own temporary heat and weather tight enclosures as required for the satisfactory performance of his work and to comply with the construction schedule. Temporary heat systems must be approved by Galveston County's authorized Representative.
 - 3. Temporary Use of Building System
 - 4. It is not anticipated that the permanent building system will be utilized to provide "temporary heat" during the major portion of construction operations
 - 5. It is anticipated that activation, testing and balancing of the building heating/cooling system will

Galveston County Project 09-012a

be critical to the completion and acceptance of the project and therefore actuation, of the permanent system will be scheduled for the earliest possible time.

6. Within these parameters the Contractor must provide any supplemental heat required to perform his work.
7. In the proposal form, the Contractor may be requested to indicate an amount included for "supplemental heat" (not construction heating) as Galveston County's authorized Representative may request proposals for providing an interim heating system from the Mechanical Contractor. (Review Scope of Work Carefully).

D. Temporary Water

1. Potable water shall be available to the Contractor at a central location. Extensions of the water supply for Contractor's exclusive use shall be the responsibility of the Contractor.
2. Temporary water distribution as indicated on Site Utilization will be provided for the use of all Contractors and to provide a temporary fire protection system.
3. The temporary fire protection system shall be installed using the permanent standpipes and risers, and shall be installed as rapidly as construction permits.
4. Temporary fire standpipe connections, including pipe fittings, and valves shall be provided at the location of each permanent hose rack or station as shown on the contract drawings.
5. At each temporary riser connection shall be provided a temporary hose rack, 100 feet of 1-1/2" UL approved fire hose system with brass couplings and a 1-1/2" nozzle. The system shall also provide 2-1/2" valved, capped connection at each location together with 1-1/2" valved connection with a pair of hose bibs. Hose adapters on the discharge side of the 2-1/2" valve shall be compatible with hose fittings used by the local fire department.
6. All Contractors are responsible for providing their own hoses to bring water from the hose rack location to their work areas. Only heavy-duty 3/4" hose in good conditions will be permitted in use in the interior of the building. The discharge end of each hose shall be equipped with a means of positive shut off. The use of hoses, which leak at connections or elsewhere throughout their length, will not be permitted. All hoses shall be disconnected from hose bibs when not in use and before the end of each work day.
7. When no longer required, as determined by Galveston County's authorized Representative, the temporary systems shall be dismantled and removed.
8. Water will be provided to all Contractors without cost, and any billings therefore will be paid by Galveston County's authorized Representative.
9. The Plumbing Contractor may be requested in the Proposal Package "Scope of Work" to include furnishing installing and dismantling and removing the temporary water/temporary fire protection system described above.
10. In such event the temporary equipment and materials so removed shall become the property of the Plumbing Contractor. (Review Scope of Work Carefully)

E. Housekeeping - Cleaning and Rubbish Removal

1. Each Contractor shall be responsible for daily and final cleanup and continuous removal of all rubbish and debris from the building and site. Galveston County's authorized Representative shall provide, erect, locate, and maintain a rubbish chute and/or rubbish collection dumpster system for use of all trades. Each Contractor shall be responsible to deposit his daily rubbish into these chutes or dumpster locations as designated and provided by Galveston County's authorized Representative. Failure of a Contractor to do so will require that this be done by Galveston County's authorized Representative after proper notice to the Contractor and labor for doing so shall be charged to the responsible Contractor
2. The jobsite shall be maintained in a neat orderly condition and kept free from accumulations of waste materials and rubbish during the entire construction period. Contractor will remove all crates, cartons and other flammable waste materials or trash from the work areas at the end of each working day.
3. Elevator shafts, electrical closets, pipe and duct shafts, chases, furred spaces and similar spaces which are generally unfinished, shall be cleaned and left free from rubbish, loose plaster, mortar drippings, extraneous construction materials, dirt and dust before substantial completion review.
4. Each Contractor shall be responsible for cleaning all surfaces as necessary to make them free of spatters or other deposits of paint, plaster, mortar, concrete, adhesives, roofing, dirt, soil, oil, or any other material foreign to the surface involved. Galveston County's authorized Representative

Galveston County Project 09-012a

- shall back-charge to the guilty party the cost of cleaning which is required by accidental soiling or damage by another Contractor.
5. Each Contractor is responsible to share the task of litter cleanup (e.g., coffee cups, lunch wrappers, etc.).
 6. However, to insure proper cleanup, notwithstanding the Contractor's obligations to cleanup any debris resulting from his own operations, and following proper notices Galveston County's authorized Representative will undertake the cleanup and disposal of litter and other debris whose source is unidentifiable. The cost of this special cleanup detail will be assessed weekly against all Contractors on a per capita basis and invoiced monthly. If any cleanup invoice is not paid within thirty (30) days, it will be back-charged against the respective Contractor's monthly payment application.
 7. The Contractor shall be responsible to maintain his own trailer, storage and work areas in a sanitary condition to minimize the hazard of attracting vermin and breeding mosquitoes. If the Contractor fails to comply, Galveston County's authorized Representative may do so, and the cost thereof shall be charged to the Contractor. Rodent extermination materials shall be those approved by the local health department or other agency having jurisdiction.
 8. Use only cleaning materials and methods recommended by manufacturer of surface to be cleaned. Use cleaning materials only on surfaces recommended by cleaning material manufacturer. Each Contractor shall be responsible for assuring that affected employees are provided with, and required to use, all needed personal protective devices in connection with cleaning.
 9. At completion of work, each Contractor shall remove tools, equipment, machinery, and surplus materials from the project site and perform whatever additional cleaning is specified in the Proposal Form.
- F. Vehicle cleaning - Trucking
1. Galveston County's authorized Representative will designate the wash-down area to be utilized by the Contractors. The "wheel wash station" will be equipped with a hose connection and drainage area. The Contractor shall provide manpower, hose and other supplemental scrapers, brushes, etc., which may be required to satisfactorily clean his vehicles leaving the site. The construction of this temporary facility may be included in the "Scope of Work" of the excavation or site Preparation Proposal Package, Review scope of work carefully.
 2. All vehicles shall be cleaned of all mud and debris before leaving the site. Each Contractor shall be responsible for providing whatever personnel may be required to perform the required vehicle cleaning throughout the progress of his work. The wash-down area shall not be used for cleaning out of concrete mix trucks.
 3. Cleaning of concrete equipment shall be performed at locations designated by Galveston County's authorized Representative. Cleaning shall be conducted in such a manner as to prevent spillage of fluid or concrete to the ground or penetration of existing ground soil. The responsible Contractor shall remove from the site all residues accumulated from the cleaning operations of concrete equipment..
 4. All trucks leaving the site with earthen materials or loose debris shall be loaded in a manner that will prevent dropping of materials on streets, and when necessary, shall have suitable coverings fastened over the load before they enter surrounding paved streets. Trucks bringing earthen materials over paved streets to the site shall be similarly loaded and covered. The Contractor shall conform to all local regulations regarding load limits and be responsible for any costs due to failure to comply with the above.
- G. Site Security, Personnel and Property Protection
1. Contractor shall maintain the security of the worksite and shall restrict access to the site to the following:
 - a. its employees;
 - b. employees of subcontractors;
 - c. representatives of manufacturers whose goods are utilized in the work and are called to the site by either the Contractor or the Program Administrator; and
 - d. agents and/or employees of the County.
 2. Contractor shall provide adequate protection to persons on the worksite, adjacent properties, and utilities as is necessary to keep each free of damage or injury. Contractor shall furnish all barricades,

Galveston County Project 09-012a

warning lights and other safety devices necessary for the safety and protection of the public and shall remove them upon completion of the work performed on those premises under the terms of this Contract.

3. Contractor will have complete control over the work site and shall be fully responsible for any loss of or damage to any County property from any cause and will reimburse County in the event of any loss or damage to County's property from any cause.
4. Contractor shall take proper means to protect adjacent or adjoining properties which might be injured or seriously affected by construction undertaken under this Agreement from any damage or injury by reason of said process of construction. Contractor shall be liable for any and all claims for such damage on account of its failure to fully protect all adjoining properties.
5. At no time remove, alter or render ineffective any barricades, railings or cover on the project without written permission of Galveston County's authorized Representative. Where these safety devices are to be turned over to others, upon completion of the work, the devices shall be repaired or replaced so that they meet the required standards prior to turnover.
6. The Contractor shall provide and maintain proper warnings and detour signs at all pedestrian and vehicular closures, intersections, and along detours, directing traffic around closed portions of roadways. The Contractor shall, at his own expense, wherever necessary or required, provide and maintain fences, temporary roadways, temporary cross signs, watchmen, warning lights and take such other precautions as may be necessary to protect life and property, and shall be responsible for all damages occasioned in any way by his act or neglect. All barricades and obstructions shall be illuminated at night, and all lights shall be kept on from one-half hour before sunset, until one-half hour after sunrise.
7. The Contractor shall provide such openings, channels, chases, flues, etc., if any, and do such cutting, patching, finishing, etc., if any, required by the Contract Documents.
8. Unless otherwise specified, the Contractor shall furnish and install all sleeves, inserts, hangers, etc., required for the execution of his work.
9. When performing any cutting, removal, creating opening or holes, etc., the Contractor, by use of barricades, flagmen, or other means, shall provide protective measures to assure that other workmen or the public are not exposed to potential injury by the operation being conducted.
10. The Contractor shall be responsible for handling and transporting (including lifting) his material and equipment to the location of need in a timely manner.
11. Any vertical lifting device, whether stationary material hoist, mobile crane or other means, a Contractor plans to use will be implemented only after prior coordination and approval of Galveston County's authorized Representative.

30. Order of Precedence

- A. In the event of any conflict or discrepancy in the provisions of the contract documents, the documents shall be interpreted on the basis of the following order or priority:
 1. Agreement between Owner and Contractor
 2. Proposal Form
 3. Addenda, with later date having greater priority
 4. General Conditions
 5. Project Manual
 6. Drawings, large scale details and/or schedules
 7. Drawings, small scale

31. WAGE RATES

This Contract is a Public Works Contract governed by V.T.C.A., Government Code, Chapter 2258. That Act requires Contractor to pay workers not less than the general prevailing rate of per diem wages for work of a similar character in the locality in which the work is performed and not less than the general prevailing rate of per diem wages for legal holiday and overtime work.

Prevailing wage rates determined by the United States Department of Labor in accordance with the Davis-Bacon Act (40 U.S.C. Section 276a et seq) are used in this Contract and are incorporated and made a part hereof.

In the event other crafts or types of workers are required than are listed therein, such workers shall be paid at a rate not less than the prevailing rate for similar workers in the Galveston County area.

Galveston County Project 09-012a

Contractor acknowledges that:

- A. Pursuant to V.T.C.A., Government Code §2258.022, a violation of the obligation to pay workers the prevailing wages shall result in Contractor paying the County the amount of \$60.00 for each worker employed for each calendar day or part of the day that the worker is paid less than the wage rates stipulated in the Contract; and
- B. Contractors and Subcontractors shall be required to keep a record showing the name and occupation of each worker employed by Contractor or Subcontractor in the construction of the work called for in the contract and the actual per diem wages paid to each worker.
- C. **The record shall be submitted weekly on Labor Department forms to the Galveston County Wage Compliance Officer.**
Contractor represents it has read this law and the penalties provided prior to entering into this agreement.
- D. Wage Rates in force for Galveston County are included in Section 01012 Wage Scale.

32. Force Majeure

If by reason of force Majeure either Party shall be rendered unable, wholly or in part, to carry out its responsibilities under this contract by any occurrence by reason of force Majeure, then the Party unable to carry out its responsibility shall give the other Party notice and full particulars of such force Majeure in writing within a reasonable time after the occurrence of the event, and such notice shall suspend the Party's responsibility for the continuance of the forced Majeure claimed, but for no longer period.

Force Majeure means acts of God, floods, hurricanes, tropical storms, tornadoes, earthquakes, or other natural disasters, acts of a public enemy, acts of terrorism, sovereign conduct, riots, civil commotion, strikes or lockouts, and other causes that are not occasioned by either Party's conduct which by the exercise of due diligence the Party is unable to overcome and which substantially interferes with operations.

33. Salvage

Any materials, equipment and fixtures specifically ordered to be salvaged under these specifications shall remain the property of County and will be delivered to the site designated by Galveston County's authorized Representative. All other items shall be disposed of by Contractor in compliance with all applicable laws and regulations.

34. Open Records

Contractor acknowledges that County is a governmental entity and this Agreement is an open record under the Open Records Act and will be discussed and voted upon in a public meeting.

35. Performance and Payment Bond(s)

V.T.C.A., Government Code Chapter 2253, requires a Performance Bond (for contracts in the excess of \$100,000) and a Payment Bond (for contracts in excess of \$25,000), to be provided by the Contractor. Each bond required shall be equal to the total contract price and shall be issued by a satisfactory surety company. The bond(s) will remain in full force and effect until final completion and acceptance of the work.

The bond(s) are to be made payable to the County of Galveston. They shall be written on forms provided by the surety for public works projects in Texas. A surety licensed to do business in the state of Texas must execute the bond.

Proposers should familiarize themselves with the entire provisions of V.T.C.A., Chapter 2253 and the penalties provided for its violation before submitting their Proposal.

**End of
General Terms and Conditions of the Contract**