

Bayside Community Center

Project No: 12-006

2-29-16

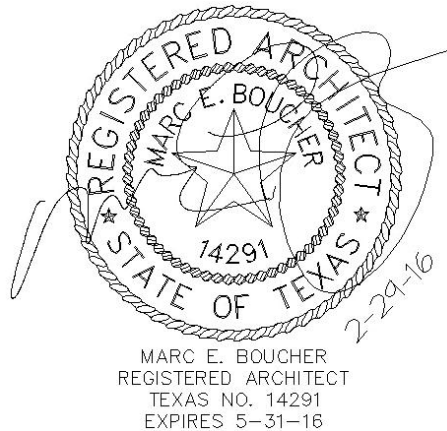

Galveston County, Texas

Commissioners Court

The Honorable Mark HenryCounty Judge
The Honorable Ryan DennardCommissioner Precinct 1
The Honorable Joe GiustiCommissioner Precinct 2
The Honorable Stephen D. HolmesCommissioner Precinct 3
The Honorable Ken ClarkCommissioner Precinct 4

DOCUMENT 00010 - TABLE OF CONTENTS

Bayside Community Center

Bid Number B161012
Bid Date 7-7-16
Bid Time 2:00 P.M.

Addendum 3: Divisions 22, 23, 26 and 28 added.
Plan Revision 1: Section 07311, "Asphalt Shingles", added.
Addendum 6: All Bid Documents revised and reissued.
Sections 00010, 08710, 09260 and 09912 revised and reissued.
Sections 07411 and 12494 added.
Sections 07610, 08332, 09220 and 10706 deleted.

	COVER SHEET	1
00010	TABLE OF CONTENTS	4
00020	PROJECT DIRECTORY	1

BID DOCUMENTS

	INVITATION TO BID	4
	GENERAL PROVISIONS	25
	BID FORM	3
	CONTRACTOR'S QUALIFICATION STATEMENT	1
	NON-COLLUSION AFFIDAVIT	1
	VENDOR QUALIFICATION PACKET	10

AGREEMENT BETWEEN GALVESTON COUNTY AND CONTRACTOR

	AGREEMENT BETWEEN GALVESTON COUNTY AND CONTRACTOR	11
	GENERAL CONDITIONS OF THE AGREEMENT	35

DIVISION 1A – GALVESTON COUNTY REQUIREMENTS

01010	SUMMARY OF THE WORK	1
01012	WAGE SCALE	1
01020	ALLOWANCES	2
01025	SCHEDULE OF VALUES	1
01045	CUTTING AND PATCHING	4
01200	PROJECT MEETINGS	1
01300	SUBMITTALS	3
01310	CONSTRUCTION SCHEDULE	1
01330	SUBMITTAL PROCEDURES	9
01420	NOTIFICATION OF ARCHITECT REQUIREMENTS	2
01500	TEMPORARY FACILITIES AND CONTROLS	7
01630	SUBSTITUTIONS	2
01710	GUARANTEES AND CERTIFICATES AND CLOSE-OUT	2

DIVISION 1B – GENERAL REQUIREMENTS

01250	CONTRACT MODIFICATION PROCEDURES	3
01290	PAYMENT PROCEDURES	4
01310	PROJECT MANAGEMENT AND COORDINATION	4
01320	CONSTRUCTION PROGRESS DOCUMENTATION	5
01360	REQUEST FOR INFORMATION	2
01361	REQUEST FOR INFORMATION FORM	2

01400	QUALITY REQUIREMENTS	7
01421	REFERENCES	2
01600	PRODUCT REQUIREMENTS	7
01700	EXECUTION REQUIREMENTS	6
01770	CLOSEOUT PROCEDURES	8
DIVISION 2- SITE CONSTRUCTION		
02750	CONCRETE PAVING	3
DIVISION 3 - CONCRETE		
03300	CAST-IN-PLACE CONCRETE	13
DIVISION 4 - MASONRY		
04200	UNIT MASONRY	14
DIVISION 5 - METALS		
05400	COLD-FORMED METAL FRAMING	4
05500	METAL FABRICATIONS	3
05910	GALVANIZING	5
DIVISION 6 - WOOD AND PLASTICS		
06100	ROUGH CARPENTRY	5
06600	SOLID POLYMER FABRICATIONS	2
DIVISION 7 - THERMAL AND MOISTURE PROTECTION		
07210	BUILDING INSULATION	3
07260	UNDER-SLAB VAPOR BARRIER	2
07270	AIR BARRIERS	4
07311	ASPHALT SHINGLES	4
07411	MANUFACTURED ROOF PANELS	2
07461	FIBER-CEMENT SIDING, TRIM AND PANELS	5
07620	SHEET METAL FLASHING AND TRIM	8
07920	JOINT SEALANTS	7
DIVISION 8 - DOORS AND WINDOWS		
08110	STEEL DOORS AND FRAMES	4
08161	FIBERGLASS DOORS AND FRAMES	5
08210	PLASTIC LAMINATE CLAD DOORS	2
08410	ALUMINUM-FRAMED ENTRANCES AND STOREFRONTS	8
08710	DOOR HARDWARE	15
08800	GLAZING	8
DIVISION 9 - FINISHES		
09253	GYPSON SHEATHING	3
09260	GYPSON BOARD ASSEMBLIES	10
09310	CERAMIC TILE	6
09511	ACOUSTICAL PANEL CEILINGS	6
09651	RESILIENT FLOOR TILE	5
09680	CARPET	4
09770	FRP WALL PANELS	3
09912	PAINTING	12
DIVISION 10 - SPECIALTIES		
10161	STAINLESS STEEL TOILET PARTITIONS	3

10350	FLAGPOLES	3
10523	FIRE EXTINGUISHERS, CABINETS AND ACCESSORIES	2
10810	TOILET ACCESSORIES	6

DIVISION 11 - EQUIPMENT

11022	LOCK BOXES	1
-------	------------	---

DIVISION 12 – FURNISHINGS

12481	ENTRANCE FLOOR MATS	3
12494	ROLLER SHADES	6

DIVISION 13 - SPECIAL CONSTRUCTION

DIVISION 14 - CONVEYING SYSTEMS

DIVISION 15 - MECHANICAL

DIVISION 16 - ELECTRICAL

NOT USED

Division 22 added with Addendum 3

DIVISION 22 - PLUMBING

220500	COMMON WORK RESULTS FOR PLUMBING	12
220519	METERS AND GAGES FOR PLUMBING PIPING	8
220529	HANGERS AND SUPPORTS FOR PLUMBING PIPING	11
220553	IDENTIFICATION FOR PLUMBING PIPING & EQUIPMENT	6
220700	PLUMBING INSULATION	9
221116	DOMESTIC WATER PIPING	11
221119	DOMESTIC WATER PIPING SPECIALTIES	11
221316	SANITARY WASTE AND VENT PIPING	7
221319	SANITARY WASTE PIPING SPECIALTIES	6
224000	PLUMBING FIXTURES	8

Division 23 added with Addendum 3

DIVISION 23 – HEATING VENTILATING AND AIR CONDITIONING

230500	COMMON WORK RESULTS IN HVAC	22
230513	MOTORS & MOTOR CONTROLLERS & VARIABLE FREQUENCY DRIVES	10
230529	HANGERS AND SUPPORTS FOR HVAC EQUIPMENT	6
230548	VIBRATION CONTROLS FOR HVAC PIPING AND EQUIPMENT	11
230593	TESTING & BALANCING OF HVAC	7
230713	HVAC INSULATION	9
230923	DIRECT DIGITAL CONTROL SYSTEM	29
233100	SHEET METAL DUCT WORK	5
233300	AIR DUCT ACCESSORIES	8
233419	HVAC POWER VENTILATORS	3
233600	AIR TERMINAL UNITS	6
233713	DIFFUSERS, REGISTERS & GRILLES	2
238133	UNITARY SPLIT SYSTEM AIR CONDITIONERS	3

Division 26 added with Addendum 3

DIVISION 26 - ELECTRICAL

260500	COMMON WORK RESULTS FOR ELECTRICAL	16
260519	LOW-VOLTAGE ELECTRICAL POWER CONDUCTORS AND CABLES	7
260526	GROUNDING AND BONDING FOR ELECTRICAL SYSTEMS	6
260529	HANGERS AND SUPPORTS FOR ELECTRICAL SYSTEMS	5

260533	RACEWAY AND BOXES FOR ELECTRICAL SYSTEMS	14
260543	UNDERGROUND DUCTS AND RACEWAYS FOR ELECTRICAL SYSTEMS	14
260553	IDENTIFICATION FOR ELECTRICAL SYSTEMS	8
262200	LOW-VOLTAGE TRANSFORMERS	6
262416	PANELBOARDS	8
262726	WIRING DEVICES	12
262813	FUSES	3
262816	ENCLOSED SWITCHES AND CIRCUIT BREAKERS	6
264313	TRANSIENT-VOLTAGE SUPPRESSION FOR LOW-VOLTAGE ELECTRICAL POWER CIRCUITS	5
265100	INTERIOR LIGHTING	11
269500	FIELD ELECTRICAL TESTING	3

Division 28 added with Addendum 1

DIVISION 28 - ELECTRONIC SAFETY AND SECURITY

283111	DIGITAL, ADDRESSABLE FIRE-ALARM SYSTEM	12
--------	--	----

END OF TABLE OF CONTENTS

DOCUMENT 00020 – PROJECT DIRECTORY

Project Name	Bayside Community Center
Location	Galveston County, Texas
Owner	County of Galveston 722 Moody Avenue, 6th Floor Galveston, Texas 77550
Architect	Boucher Design Group 6802 Mapleridge, Suite 200 Bellaire, Texas 77401 (713) 785-3644
Structural Engineer M.E.P. Engineer Civil Engineer	Infrastructure Associates, Inc. 6117 Richmond Avenue, Suite 200 Houston, Texas 77057 713-622-0120

END OF SECTION

ITB #B161012A
OPEN: 07/07/2016
TIME: 2:00 P.M.

**INVITATION TO BID
COMMUNITY CENTER AT 64 ACRE PARK, BAACLIFF, TX
GALVESTON COUNTY, TEXAS**

Sealed bids in sets of six (6), one (1) original and five (5) copies will be received in the office of the County Purchasing Agent until 2:00 P.M. CST, on Thursday, July 7, 2016 and opened immediately in that office in the presence of the Galveston County Auditor and the Purchasing Agent. Sealed bids are to be delivered to Rufus G. Crowder, CPPO CPPB, Galveston County Purchasing Agent at the Galveston County Courthouse, 722 Moody (21st Street), Floor 5, Purchasing, Galveston, Texas 77550, (409) 770-5372. **The time stamp clock located in the Purchasing Agent's office shall serve as the official time keeping piece for this solicitation process. Any bid received after 2:00 P.M. CST on the specified date will be returned unopened.**

Purpose:

Galveston County is requesting bids for general construction of Bayside Community Center.

All proposals must be marked on the outside of the envelope:

ITB #B161012A

COMMUNITY CENTER AT 64 ACRE PARK, BAACLIFF, TX

Bidders name and return address should be on the outside of the envelope.

Specifications can be obtained by visiting the Galveston County website @
<http://www.galvestoncountytexas.gov/pu/Pages/BidListing.aspx>.

Davis-Bacon rates will apply under this disaster recovery program. Attention is called to the fact that no less than the federally determined prevailing (Davis-Bacon and Related Acts) wage rate, as issued by the Office of Rural Community Affairs and contained in the contract documents, must be paid on this project. In addition, the successful bidder must ensure that employees and applicants for employment are not discriminated against because of race, color, religion, sex, age or national origin.

Bid prices shall be either lump sum or unit prices as shown on the proposal sheet, if applicable. The net price will be delivered to Galveston County, including all freight, shipping, and license fees. Galveston County is tax exempt and no taxes should be included in your proposal pricing. Bids will be completed on the forms and proposal sheets provided.

Upon satisfaction of contractual terms (e.g., goods delivered in promised condition, services rendered as agreed, etc.), contractor shall be paid via Galveston County's normal accounts payable process.

Bond Requirement:

Each bid must be accompanied by a Cashier's Check or acceptable Bidder's Bond in the amount of 5% of bid as a guarantee that, if awarded the contract, within thirty (30) days from the date of bid opening, the bidder will enter into a contract and execute Performance and Payment Bonds statutorily required for public works project. The county intends to award a contract within sixty (60) days.

All contractors/subcontractors that are debarred, suspended or otherwise excluded from or ineligible for participation on federal assistance programs may not undertake any activity in part or in full under this project.

The Galveston County Commissioners' Court reserves the right to waive any informality and to reject any and all bids and to accept the bid or bids which, in its opinion, is most advantageous to Galveston County with total respect the governing laws.

Rufus G. Crowder, CPPO CPPB
Galveston County Purchasing Agent

**GALVESTON COUNTY
PURCHASING DEPARTMENT**



INVITATION TO BID

BID #B161012A

COMMUNITY CENTER AT 64 ACRE PARK, BACLIFF, TX

BID DUE DATE: 07/07/2016

2:00 P.M. CST

***Rufus Crowder, CPPO, CPPB
Purchasing Agent
Galveston County
722 Moody (21st Street)
Fifth (5th) Floor
Galveston, Texas 77550
(409) 770-5372***



ITB #B161012A
OPEN: 07/07/2016
TIME: 2:00 P.M.

INVITATION TO BID
COMMUNITY CENTER AT 64 ACRE PARK, BAACLIFF, TX
GALVESTON COUNTY, TEXAS

Sealed bids in sets of six (6), one (1) original and five (5) copies will be received in the office of the County Purchasing Agent until **2:00 P.M. CST**, on Thursday, July 7, 2017 and opened immediately in that office in the presence of the Galveston County Auditor and the Purchasing Agent. Sealed bids are to be delivered to Rufus G. Crowder, CPPO CPPB, Galveston County Purchasing Agent at the Galveston County Courthouse, 722 Moody (21st Street), Floor 5, Purchasing, Galveston, Texas 77550, (409) 770-5372. **The time stamp clock located in the Purchasing Agent's office shall serve as the official time keeping piece for this solicitation process. Any bid received after 2:00 P.M. CST on the specified date will be returned unopened.**

Purpose:

Galveston County is requesting bids for general construction of Bayside Community Center.

All proposals must be marked on the outside of the envelope:

ITB #B161012A

COMMUNITY CENTER AT 64 ACRE PARK, BAACLIFF, TX

Bidders name and return address should be on the outside of the envelope.

Specifications can be obtained by visiting the Galveston County website @
<http://www.galvestoncountytexas.gov/pu/Pages/BidListing.aspx>.

Davis-Bacon rates will apply under this disaster recovery program. Attention is called to the fact that no less than the federally determined prevailing (Davis-Bacon and Related Acts) wage rate, as issued by the Office of Rural Community Affairs and contained in the contract documents, must be paid on this project. In addition, the successful bidder must ensure that employees and applicants for employment are not discriminated against because of race, color, religion, sex, age or national origin.

Bid prices shall be either lump sum or unit prices as shown on the proposal sheet, if applicable. The net price will be delivered to Galveston County, including all freight, shipping, and license fees. Galveston County is tax exempt and no taxes should be included in your proposal pricing. Bids will be completed on the forms and proposal sheets provided.

Upon satisfaction of contractual terms (e.g., goods delivered in promised condition, services rendered as agreed, etc.), contractor shall be paid via Galveston County's normal accounts payable process.

Bond Requirement:

Each bid must be accompanied by a Cashier's Check or acceptable Bidder's Bond in the amount of 5% of bid as a guarantee that, if awarded the contract, within thirty (30) days from the date of bid opening, the bidder will enter into a contract and execute Performance and Payment Bonds statutorily required for public works project. The county intends to award a contract within sixty (60) days.

All contractors/subcontractors that are debarred, suspended or otherwise excluded from or ineligible for participation on federal assistance programs may not undertake any activity in part or in full under this project.

The Galveston County Commissioners' Court reserves the right to waive any informality and to reject any and all bids and to accept the bid or bids which, in its opinion, is most advantageous to Galveston County with total respect the governing laws.

Rufus G. Crowder, CPPO CPPB
Purchasing Agent
Galveston County

**COMMUNITY CENTER AT 64 ACRE PARK, BACLIFF, TX
GALVESTON COUNTY, TEXAS**

Table of Contents

GENERAL PROVISIONS:

1.	BID PACKAGE	1
2.	BIDDER'S RESPONSIBILITY	1
3.	TIME FOR RECEIVING BIDS	1
4.	COMPETITIVENESS, INTEGRITY, INQUIRIES AND QUESTIONS.....	2
5.	BID OPENING	2
6.	COMMISSIONERS' COURT	2
7.	REJECTION OF BIDS/DISQUALIFICATION	3
	A.Failure to use the Bid form(s) furnished by the County;.....	3
8.	RESTRICTIVE OR AMBIGUOUS SPECIFICATIONS	3
9.	SUBSTITUTES/DESCRIPTION OF MATERIALS AND EQUIPMENT	3
10.	EXCEPTIONS TO BID	3
11.	PRICING	4
12.	PROCUREMENT CARD PROGRAM	4
13.	PASS THROUGH COST ADJUSTMENTS.....	4
14.	MODIFICATION OF BIDS	4
15.	SIGNATURE OF BIDS	5
16.	AWARD OF BIDS – EVALUATION CRITERIA AND FACTORS.....	5
17.	DISPUTE AFTER AWARD/PROTEST	6
18.	PUBLIC INFORMATION ACT	6
19.	BIDDER'S EMAIL ADDRESSES	6
20.	RESULTANT CONTRACT	7
21.	CONTRACT TERM.....	7
22.	TERMINATION FOR DEFAULT	7
23.	TERMINATION FOR CONVENIENCE	7
24.	FORCE MAJEURE.....	8
25.	ESTIMATED QUANTITIES	8

**COMMUNITY CENTER AT 64 ACRE PARK, BAACLIF, TX
GALVESTON COUNTY, TEXAS**

26.	CONTRACTOR INVESTIGATION.....	8
27.	NO COMMITMENT BY COUNTY OF GALVESTON.....	8
28.	BID COSTS BORNE BY BIDDER	8
29.	BEST AND FINAL OFFERS (BAFO)	8
30.	SINGLE BID RESPONSE.....	9
31.	CHANGES IN SPECIFICATIONS.....	9
32.	BID IDEAS AND CONCEPTS	9
33.	BID DISCLOSURES	9
34.	WITHDRAWAL OF BID	9
35.	INDEMNIFICATION	9
36.	REQUIREMENT OF AND PROOF OF INSURANCE	10
37.	BID GUARANTEE	11
38.	PERFORMANCE AND PAYMENT BONDS.....	11
39.	PATENT AND COPYRIGHT PROTECTION	12
40.	CONFLICT OF INTEREST DISCLOSURE REPORTING	12
41.	CERTIFICATION REGARDING DEBARMENT, SUSPENSION, PROPOSED DEBARMENT AND OTHER RESPONSIBILITY MATTERS.....	14
42.	NON-COLLUSION AFFIDAVIT	14
43.	SOVEREIGN IMMUNITY	15
44.	CONTROLLING LAW AND VENUE	15
45.	MERGERS, ACQUISITIONS	15
46.	DELAYS.....	15
47.	ACCURACY OF DATA.....	15
48.	SUBCONTRACTING/ASSIGNMENT.....	15
49.	INDEPENDENT CONTRACTOR.....	16
50.	MONITORING PERFORMANCE	16
51.	PROCUREMENT ETHICS	16
52.	SUBJECT TO APPROPRIATION OF FUNDS	17
53.	NON-DISCRIMINATION.....	18
54.	RECORD RETENTION AND RIGHT TO AUDIT	18

**COMMUNITY CENTER AT 64 ACRE PARK, BAACLIF, TX
GALVESTON COUNTY, TEXAS**

55.	TITLE VI ASSURANCES/TXDOT	19
56.	SECTION 231.006, FAMILY CODE/DELINQUENT CHILD SUPPORT	20
57.	ANTITRUST.....	20
58.	LABOR STANDARDS.....	20
59.	ENTIRETY OF AGREEMENT AND MODICATION.....	20
60.	NOTICES.....	20

**GENERAL PROVISIONS
COMMUNITY CENTER AT 64 ACRE PARK, BAACLIFF, TX
GALVESTON COUNTY, TEXAS**

1. BID PACKAGE:

The Invitation to Bid, general and special provisions, drawings, specifications/line item details, contract documents and the Bid sheet are all part of the Bid package. BIDs must be submitted in sets of six (6), one (1) original and five (5) copies on the forms provided by the County if provided, including the Bid sheets completed in their entirety and signed by an authorized representative by original signature. Failure to complete and sign the Bid sheets/contract page(s) may disqualify the Bid from being considered by the Commissioners' Court. Any individual signing on behalf of the Bidder expressly affirms that he or she is duly authorized to tender this Bid and to sign the Bid sheet/contract under the terms and conditions in this bid. Bidder further understands that the signing of the contract shall be of no effect unless subsequently awarded and the contract properly executed by the Commissioners' Court. All figures must be written in ink or typed. Figures written in pencil or with erasures are not acceptable. However, mistakes may be crossed out, corrections inserted, and initialed in ink by the individual signing the bid. If there are discrepancies between unit prices quoted and extensions, the unit price shall prevail. Each Bidder is required to thoroughly review this entire Bid package to familiarize themselves with the Bid procedures, the plans and specifications for the requested work, as well as the terms, and conditions of the contract the successful Bidder will execute with the County.

2. BIDDER'S RESPONSIBILITY

The Bidder must affirmatively demonstrate its responsibility. The Bidder must also meet the following minimum requirements:

- A. have adequate financial resources or the ability to obtain such resources as required;
- B. be able to comply with all federal, state, and local laws, rules, regulations, ordinances and orders regarding this Request for Bid;
- C. have a satisfactory record of performance;
- D. have a satisfactory record of integrity and ethics;
- E. and be otherwise qualified and eligible to receive an award.

3. TIME FOR RECEIVING BIDS:

Bids may be submitted by mail or hand delivery and must be submitted to the Galveston County Purchasing Agent. If by delivery, the Bidder must deliver to the reception desk in the County Purchasing Agent's Office. The delivery and mailing instructions for the Galveston County Purchasing Agent are the following:

**Rufus Crowder, CPPO CPPB
Galveston County Purchasing Agent
722 Moody, Fifth (5th) Floor
Galveston, Texas 77550**

Bids will **not** be accepted by facsimile transmission or by electronic mail (email) unless superseded by instructions within the Special Provisions of this solicitation. Bids must be received by the County Purchasing Agent on or before the deadline for the opening of the bids. For clarity, mailing date/postmark is **not** sufficient – bids **must be received** by the County Purchasing Agent on or before the deadline. Late bids will not be accepted and will be returned to the bidder unopened. Bids received prior to the submission deadline will be maintained unopened until the specified time for opening.

The County Purchasing Agent will accept bids from 8:00 a.m. to 5:00 p.m. on each business day up to the submission deadline. Business days do not include Saturdays and Sundays, and do not include other days in which the County is closed for business in observance of holidays or for other reasons.

The time-stamp clock within the County Purchasing Agent's Office shall be the official time-clock for the purpose of this solicitation and thus shall be the determinant of whether the bid was timely received.

**GENERAL PROVISIONS
COMMUNITY CENTER AT 64 ACRE PARK, BA CLIFF, TX
GALVESTON COUNTY, TEXAS**

The bidder should prominently identify the procurement number and name on the outside of the envelope/ mailing package. A label shall be provided for this purpose and usage of the label is preferred. If the bidder fails to identify the bid on the outside of the envelop as required, the Purchasing Agent will open the envelope for the sole purpose of identifying the bid number for which the submission was made. The envelope will then be resealed. No liability will attach to a County office or employee for the premature opening of a bid.

If you do not submit a bid, return this Invitation to Bid and state reason, otherwise your name may be removed from the Purchasing Gent's mailing list.

4. COMPETITIVENESS, INTEGRITY, INQUIRIES AND QUESTIONS

To prevent biased evaluations and to preserve the competitiveness and integrity of the procurement, **bidders are to direct all communications regarding this invitation to bid to the Galveston County Purchasing Agent**, unless otherwise specifically noted.

Do not contact the requesting department. Attempts by offering firms to circumvent this requirement will be viewed negatively and may result in rejection of the bid of the firm found to be in non-compliance.

All questions regarding this Invitation to Bid must be submitted in writing to:

**Rufus Crowder, CPPO CPPB, Purchasing Agent
722 Moody
Fifth (5th) Floor
Galveston, Texas 77550
Fax: (409) 621-7997
E-mail: rufus.crowder@co.galveston.tx.us**

All questions received and the responses thereto will be mailed, emailed, or faxed to all prospective bidders. No inquires except clarification of instructions will be addressed by telephone.

Bidder is advised to carefully review this Invitation to Bid – it provides specific information necessary to aid participating firms in formulating a thorough response. Bidder's failure to examine all documents shall not entitle the bidder to any relief from the conditions imposing in the Invitation to Bid and the resultant contract.

An authorized person from the bidder must sign the bid. This signatory must be a person from the submitting firm who is duly authorized to tender and sign the bid on behalf of the bidder and t bind the contract. By this signature, the bidder further acknowledge that the bidder has read the bid documents thoroughly before submitting a bid and will fulfill the obligations in accordance to the terms, conditions, and specifications herein.

5. BID OPENING:

Information read aloud at the bid opening is the sole discretion of the Purchasing Agent. The Purchasing Agent will examine Bids promptly and thoroughly. No Bid may be withdrawn for a period of sixty (60) calendar days of the Bid opening date.

6. COMMISSIONERS' COURT:

No contract is binding on the County until it is properly placed on the Commissioners' Court agenda, approved in open Court, authorized to be executed by the County Judge, and fully executed by both parties.

Department heads and elected officials are not authorized to enter into any type of agreement or contract on behalf of the County. Only the Commissioners' Court acting as a body may enter into a contract on behalf of and contractually

**GENERAL PROVISIONS
COMMUNITY CENTER AT 64 ACRE PARK, BA CLIFF, TX
GALVESTON COUNTY, TEXAS**

bind the County. Additionally, department heads and elected officials are not authorized to agree to any type of supplemental agreements or contracts for goods or services. Supplemental agreements are subject to review by the County Legal Department prior to being accepted and signed by the County's authorized representative.

7. REJECTION OF BIDS/DISQUALIFICATION:

Galveston County, acting through its Commissioners' Court, reserves the right to:

- reject any and all Bids in whole or in part received by reason of this request for bid;
- to waive any informality in the Bids received;
- to disregard the Bid of any Bidder determined to be not responsible and/or;
- to discontinue its efforts for any reason under this Bid package at any time prior to actual execution of contract by the County.

Bidders may be disqualified and rejection of Bids may be recommended to the Commissioners' Court for any of (but not limited to) the following causes:

- A. Failure to use the bid forms furnished by the County, if applicable;
- B. Lack of signature by an authorized representative of bidder;
- C. Failure to properly complete the bid;
- D. Failure to meet the mandatory requirements of this invitation to bid; and/or
- E. Evidence of collusion among bidders.

8. RESTRICTIVE OR AMBIGUOUS SPECIFICATIONS:

It is the responsibility of the prospective Bidder to review the entire Invitation to Bid packet and to notify the Purchasing Department if the specifications are formulated in a manner that would restrict competition or appear ambiguous. Any protest or question(s) regarding the specifications or Bid procedures must be received in the Purchasing Department not less than seventy-two (72) hours prior to the time set for Bid opening. Vendors are to submit Bid as specified herein or propose an approved equal.

9. SUBSTITUTES/DESCRIPTION OF MATERIALS AND EQUIPMENT:

Any brand name or manufacturer reference used herein is intended to be descriptive and not restrictive, unless otherwise noted, and is used to indicate the type and quality of material. The term "or equal" if used, identifies commercially produced items that have the essential performance and salient characteristics of the brand name stated in the item description. All supplies, material, or equipment shall be new and of the most suitable grade for the purpose intended. It is not the County's intent to discriminate against any materials or equipment of equal merit to those specified. However, if Bidder desires to use any substitutions, prior written approval must be obtained from the County Purchasing Agent and sufficiently in advance such that an addendum may be issued. All material supplied must be one hundred percent (100%) asbestos free. Bidder, by submission of its bid, certifies that if awarded any portion of this procurement, the bidder will supply only material and equipment that is 100% asbestos free.

10. EXCEPTIONS TO BID:

The Bidder will list on a separate sheet of paper any exceptions to the conditions of the bid. This sheet will be labeled, "Exceptions to Bid Conditions", and will be attached to the bid. If no exceptions are stated, it will be understood that all general and specific conditions will be complied with, without exception.

The Bidder must specify in its Bid any alternatives it wishes to propose for consideration by the County. Each alternative should be sufficiently described and labeled within the Bid and should indicate its possible or actual advantage to the program being offered.

The County reserves the right to offer these alternatives to other Bidders.

GENERAL PROVISIONS
COMMUNITY CENTER AT 64 ACRE PARK, BAACLIF, TX
GALVESTON COUNTY, TEXAS

11. PRICING:

Bids will be either lump sum or unit prices as shown on the Bid sheet. The net priced items will be delivered to Galveston County, including all freight or shipping charges.

Cash discount must be shown on bid, otherwise prices will be considered net. Unless prices and all information requested are complete, Bid may be disregarded and given no consideration.

In case of default by the contractor, the County of Galveston may procure the articles or services from other sources and may deduct from any monies due, or that may thereafter become due to the contractor, the difference between the price named in the contract of purchase order and the actual cost thereof to the County of Galveston. Prices paid by the County of Galveston shall be considered the prevailing market price at the time such purchase is made. Periods of performance may be extended if the facts as to the cause of delay justify such extension in the opinion of the Purchasing Agent and the Commissioners' Court.

12. PROCUREMENT CARD (P-CARD) PROGRAM:

The County of Galveston participates in a Procurement Card (P-Card) program that allows payments made to a vendor by credit card. This method normally results in substantially faster bill payments, sometimes within three (3) to five (5) days of the actual transaction date. All transaction fees from the card provider are to be paid by the successful contractor. If your company will accept payment via credit card (Visa, MasterCard), please notate this in your Bid submittal.

13. PASS THROUGH COST ADJUSTMENTS:

Except in instances of extreme extenuating circumstances Contractor prices shall remain firm throughout the Contract period and any renewals. Examples of extreme extenuating circumstances include such situations as a nationwide rail strike, oil shortage or oil embargo.

In extreme extenuating circumstances, Contractors may be allowed to temporarily "pass through" additional costs they are forced to incur through no fault of their own. A request for a pass through cost increase will not be considered unless a Contractor's cost for his product exceeds 10% over the original cost for the product. Also, the increase in cost must be nationwide and consistent for a minimum period of sixty (60) days. Costs that historically are anticipated to rise over a period of time (for example only, such as wages or insurance costs) do not qualify for pass through. If a Contractor thinks he will be asking for a pass through cost adjustment during the term of the contract, then the original cost of the product to Contractor must be stated in Contractor's original bid.

A request for a pass through cost does not guarantee that one will be granted. Contractors must submit such information on each request as is required by the County Purchasing Agent. The County Purchasing Agent will review each request on a case-by-case basis and determine the appropriateness of each request as well as amount and duration of increase. Contractors will not be permitted any additional compensation for mark-ups or profits based on the increase in price. Rather, such additional compensation will be limited to the actual increase in original cost to the Contractor as such increase is reflected by the original cost stated in the bid. But in no event will the amount of additional compensation exceed 25% increase in Contractor's original cost for his product as such cost is reflected in Contractor's original Bid or the duration exceed a period of sixty (60) days. In addition, should, during the period of the pass through, cost return to normal or decrease to below pre pass through prices, appropriate downward adjustments will be made. No more than one pass through adjustment will be permitted per year.

14. MODIFICATION OF BIDS:

A Bidder may modify a bid by letter at any time prior to the submission deadline for receipt of Bids. Modification requests must be received prior to the submission deadline. Modifications made before opening time must be initiated by Bidder guaranteeing authenticity. Bids may not be amended or altered after the official opening with the single exception that any product literature and/or supporting data required by the actual specifications, if any, will be accepted at any time prior to the Commissioners' Court considering of same.

**GENERAL PROVISIONS
COMMUNITY CENTER AT 64 ACRE PARK, BACLIF, TX
GALVESTON COUNTY, TEXAS**

15. SIGNATURE OF BIDS:

Each Bid shall give the complete mailing address of the Bidder and be signed by an authorized representative by original signature with the authorized representative's name and legal title typed below the signature line. Each bid shall include the Bidder's Federal Employer Identification Number (FEIN). Failure to sign the Contract page(s) and bid response sheets may disqualify the bid from being considered by the County. The person signing on behalf of the Bidder expressly affirms that the person is duly authorized to tender the bid and to sign the bid sheets and contract under the terms and conditions of this Invitation to Bid and to bind the Bidder thereto and further understands that the signing of the contract shall be of no effect until it is properly placed on the Commissioners' Court agenda, approved in open Court, authorized to be executed by the County Judge, and fully executed by both parties.

16. AWARD OF BIDS – EVALUATION CRITERIA AND FACTORS:

The award will be made to the responsible Bidder whose bid is determined to be the lowest and best evaluated offer demonstrating the best ability to fulfill the requirements set forth in this Invitation to Bid. **The proposed cost to the County will be considered firm and cannot be altered after the submission deadline, unless the County invokes its right to request a best and final offer.**

“Lowest and best” means a bid or offer providing the best value considering associated direct and indirect costs, including transport, maintenance, reliability, life cycle, warranties, and customer service after a sale.

Each Bidder, by submitting a bid, agrees that if their bid is accepted by the Commissioners' Court, such Bidder will furnish all items and services upon which prices have been tendered and upon the terms and conditions in this bid and contract.

The contractor shall commence work only after the transmittal of a fully executed contract and after receiving written notification to proceed from the County Purchasing Agent. The contractor will perform all services indicated in the bid in compliance with this contract.

Neither department heads nor elected officials are authorized to sign any binding contracts or agreements prior to being properly placed on the Commissioners' Court agenda and approved in open court. Department heads and other elected officials are not authorized to enter into any type of agreement or contract on behalf of Galveston County. Only the Commissioners' Court, acting as a body, may enter into a contract on behalf of the County. Additionally, department heads and other elected officials are not authorized to agree to any type of supplemental agreements or contracts for goods or services. Supplemental agreements are subject to review by the County Legal Department prior to being signed by the County's authorized representatives.

The County of Galveston reserves the right to accept bids on individual items listed, or group items, or on the bid as a whole; to reject any and all bids; to waive any informality in the bids; and to accept the bid that appears to be in the best interest of the County. The selection process may, however, include a request for additional information or an oral presentation to support the written bid.

In determining and evaluating the best bid, the pricing may not necessarily be controlling, but quality, equality, efficiency, utility, general terms, delivery, suitability of the service offered, and the reputation of the service in general use will also be considered with any other relevant items. The Commissioners' Court shall be the sole judge in the determination of these matters.

The County reserves the right to reject any or all Bids in whole or in part received by reason of this Invitation to Bid and may discontinue its efforts under this Invitation to Bid for any reason or no reason or solely for the County's convenience at any time prior to actual execution of the contract by the County.

**GENERAL PROVISIONS
COMMUNITY CENTER AT 64 ACRE PARK, BAACLIFF, TX
GALVESTON COUNTY, TEXAS**

A Bidder whose bid does not meet the mandatory requirements set forth in this Invitation to Bid will be considered non-compliant.

The invitation to submit a bid which appears in the newspaper, or other authorized advertising mediums, these general provisions, the specifications which follow, the Bid sheets, and any addenda issued are all considered part of the Bid.

Each Bidder, by submitting a bid, agrees that if its bid is accepted by the Commissioners' Court, such Bidder will furnish all items and services upon the terms and conditions in this Invitation to Bid and the resultant contract.

Notice of contract award will be made within ninety (90) days of opening of Bids to the lowest responsive and responsible contractor, whose bid complies with all the requirements in the Invitation to Bid.

Contractor shall submit to the County, for approval, within ten (10) days from notice of contract award, all Certificates of Insurance evidencing the required coverage as described under Section 36, Requirement of and Proof of Insurance.

The contractor shall not commence work under these terms and conditions of the contract until all applicable Certificates of Insurance, Performance and Payment Bonds, and Irrevocable Letters of Credit (if required) have been approved by the County of Galveston and the Contractor has received notice to proceed in writing and an executed copy of the contract from the County Purchasing Agent.

17. DISPUTE AFTER AWARD/PROTEST:

Any actual or prospective Bidder who is allegedly aggrieved in connection with the solicitation of this Invitation to Bid or award of a contract resulting therefrom may protest. The protest shall be submitted in writing to the Purchasing Agent within seven (7) calendar days after such aggrieved person knows of or should have known of the facts giving rise thereto. If the protest is not resolved by mutual agreement, the Purchasing Agent will promptly issue a decision in writing to the protestant. If the protestant wishes to appeal the decision rendered by the Purchasing Agent, such appeal must be made to the Commissioners' Court through the Purchasing Agent. The decision of the Commissioners' Court will be final. The Commissioners' Court need not consider protests unless this procedure is followed.

18. PUBLIC INFORMATION ACT (f/k/a Open Records Act):

The bidder acknowledges that the County is a government body for purposes of the Public Information Act codified as Chapter 552 of the Texas Government Code, and as such is required to release information in accordance with the provisions of the Public Information Act.

If bidder considers any of its submitted information to be proprietary in nature, trade secret, or otherwise confidential, then it must clearly and conspicuously mark such information as proprietary, trade, secret, or confidential. By the submission of its bid, Bidder expressly affirms that it has clearly and conspicuously marked any information within its submission that is considers to be confidential, proprietary, and/or trade secret.

In the event the County receives a request for information under the Public Information Act seeking information that the Bidder has marked as confidential, proprietary, and /or trade secret, then the County agrees that it shall provide notice to the Bidder of the request for decision process under the Public Information Act – thus, the County will submit initial correspondence to the Texas Attorney General. Bidder is deemed to have knowledge of the Public Information Act. **By the submission of its bid, bidder expressly acknowledges that the burden to withhold its' information from public disclosure lays with the bidder;** thus, bidder further acknowledges and agrees that it shall submit comments to the Texas Attorney General in the request for decision process if bidder wishes to have its information withheld from public disclosure.

**GENERAL PROVISIONS
COMMUNITY CENTER AT 64 ACRE PARK, BAACLIF, TX
GALVESTON COUNTY, TEXAS**

19. BIDDER'S E-MAIL ADDRESSES:

Notwithstanding the foregoing Section 18, Bidder acknowledges and agrees that the confidentiality of any and all email addresses it uses or discloses in communicating with the County are open to the public in accordance with Section 552.137 of the Government Code and consents to the release of its email addresses.

20. RESULTANT CONTRACT:

Bidder shall correctly and fully execute the resultant contract first. After this, the contract shall be set for consideration by the Commissioners' Court. If the Commissioners' Court authorizes the execution of the contract, the resultant contract shall become effective upon the Commissioners' Court execution of same. Contract documents shall consist of the contract, the general and special provisions, the drawings, bid package (including best and final offer(s) if such is utilized), any addenda issued, and any change orders issued during the work. If applicable to the attached bid, bidder must sign three (3) original contracts and return with their bid submittal.

Bidder should submit a proposed contract with its Bid or its sample material terms and conditions.

21. CONTRACT TERM:

The term of the resultant contract will begin on the date of execution by the Commissioners' Court, whichever is later, and will terminate on the date specified in the resultant contract unless terminated earlier as herein set forth.

22. TERMINATION FOR DEFAULT:

Failure of either party in the performance of any of the provisions of this contract shall constitute a breach of contract, in which case either party may require corrective action within ten (10) days from date of receipt of written notice citing the exact nature of such breach. Failure of the party being notified to take corrective action within the prescribed ten (10) days, or failure to provide written reply of why no breach has occurred, shall constitute a Default of Contract.

All notices relating to default by Bidder of the provisions of the contract shall be issued by County by its Legal Department, and all replies shall be made in writing to the County Legal Department. Notices issued by or issued to anyone other than the County Legal Department shall be null and void and shall be considered as not having been issued or received.

Galveston County reserves the right to enforce the performance of this contract in any manner prescribed by law in the event of breach or default of this contract, and may contract with another party, with or without solicitation of bids or further negotiations. At a minimum, Bidder shall be required to pay any difference in service or materials, should it become necessary to contract with another source, plus reasonable administrative costs and attorney fees.

In the event of Termination for Default, Galveston County, its agents or representatives shall not be liable for loss of any profits anticipated to be made by Bidder.

In addition to the remedies stated herein, the County has the right to pursue other remedies permitted by law or in equity.

No waiver by either party of any event of default under this agreement shall operate as a waiver of any subsequent default under the terms of this agreement.

County reserves the right to terminate this contract immediately in the event Bidder:

- A. Fails to meet delivery or completion schedules; and/or
- B. Fails to otherwise perform in accordance with the accepted Bid and the contract.

23. TERMINATION FOR CONVENIENCE:

County may terminate this contract upon at least thirty (30) calendar days prior written notice for its convenience or for any reason deemed by the County to serve the public interest. As well, County may terminate this contract upon

GENERAL PROVISIONS
COMMUNITY CENTER AT 64 ACRE PARK, BAACLIF, TX
GALVESTON COUNTY, TEXAS

thirty (30) calendar days prior written notice for any reason resulting from any governmental law, order, ordinance, regulations, or court order. In no event shall County be liable for loss of any profits anticipated to be made hereunder by Bidder should this contract be terminated early.

24. FORCE MAJEURE:

If by reason of Force Majeure either Party shall be rendered unable, wholly or in part, to carry out its responsibilities under this contract by any occurrence by reason of Force Majeure, then the Party unable to carry out its responsibility shall give the other Party notice and full particulars of such Force Majeure in writing within a reasonable time after the occurrence of the event, and such notice shall suspend the Party's responsibility for the continuance of the Force Majeure claimed, but for no longer period.

Force Majeure means acts of God, floods, hurricanes, tropical storms, tornadoes, earthquakes, or other natural disasters, acts of a public enemy, acts of terrorism, sovereign conduct, riots, civil commotion, strikes or lockouts, and other causes that are not occasioned by either Party's conduct which by the exercise of due diligence the Party is unable to overcome and which substantially interferes with operations.

25. ESTIMATED QUANTITIES:

Any reference to quantities shown in the Invitation to Bid is an estimate only. Since the exact quantities cannot be predetermined, the County reserves the right to adjust quantities as deemed necessary to meet its requirements.

26. CONTRACTOR INVESTIGATION:

Before submitting a bid, each Bidder shall make all investigations and examinations necessary to ascertain all site conditions and requirements affecting the full performance of the contract and to verify any representations made by the County upon which the contractor will rely. If the contractor receives an award as a result of its bid submission, failure to have made such investigations and examinations will in no way relieve the contractor from its obligation to comply in every detail with all provisions and requirements of the contract, nor will a plea of ignorance of such conditions and requirements be accepted as a basis for any claim whatsoever by the contractor for additional compensation and/or for excused nonperformance.

27. NO COMMITMENT BY COUNTY OF GALVESTON:

This Invitation to Bid does not commit the County of Galveston to award any costs or pay any costs, or to award any contract, or to pay any costs associated with or incurred in the preparation of a bid in response to this Invitation to Bid and does not commit the County of Galveston to procure or contract for services or supplies.

28. BID COSTS BORNE BY BIDDER:

Galveston County shall not be liable for any costs incurred by Bidder in preparation, production, or submission of a bid and shall not be liable for any work performed by Bidder prior to issuance of fully executed contract and properly issued notice to proceed. Galveston County shall not be liable for any costs incurred by Bidder by reason of attending a pre-Bid conference. Galveston County shall not be liable for any costs incurred by Bidder by reason of the County invoking use of best and final offers.

29. BEST AND FINAL OFFERS (BAFO):

In acceptance of bids, the County of Galveston reserves the right to negotiate further with one or more of the Bidders as to any features of their bids and to accept modifications of the work and price when such action will be in the best interest of the County. This includes solicitation of a Best and Final Offer from one or more of the Bidders. If invoked, this allows acceptable Bidders the opportunity to amend, change or supplement their original bid. Bidders may be contacted in writing requesting that they submit their Best and Final Offer. Any such Best and Final Offer must include discussed and negotiated changes.

**GENERAL PROVISIONS
COMMUNITY CENTER AT 64 ACRE PARK, BAACLIFF, TX
GALVESTON COUNTY, TEXAS**

30. SINGLE BID RESPONSE:

If only one bid is received in response to the Invitation to Bid, a detailed cost bid may be requested of the single contractor. A cost/price analysis and evaluation and/or audit may be performed of the cost bid in order to determine if the price is fair and reasonable.

31. CHANGES IN SPECIFICATIONS:

If it becomes necessary to revise any part of this bid, a written notice of such revision will be provided to all Bidders in the form of addenda. The County is not bound by any oral representations, clarifications, or changes made in the written specifications by the County's employees, unless such clarification or change is provided to Bidders in a written addendum from the Purchasing Agent. Bidders are advised to inquire prior to the submission deadline as to whether any addenda to this invitation to bid have been issued, as the successful bidder will be required to abide by such addenda.

The County of Galveston reserves the right to revise or amend the specifications up to the time set for opening of bids. Such revisions and amendments, if any, shall be announced by amendments to the solicitation. Copies of such amending or revising addenda (or addendum in the event only one addendum is issued in the procurement) shall be furnished to all prospective contractors. Prospective contractors are defined as those contractors listed on the County's Invitation to Bid list for this material/service or those who have obtained documents subsequent to the advertisement. If revisions and amendments require changes in quantities or prices proposed, or both, the date set for opening of bids may be postponed by such number of days as in the opinion of the County shall enable contractors to revise their bids. In any case, the bid opening shall be at least five (5) business days after the last revising or amendment addendum shall include an announcement of the new date, if applicable, for the opening or bids.

32. BID IDEAS AND CONCEPTS:

The County reserves to itself the right to adopt or use for its benefit, any concept, plan, or idea contained in any bid.

33. BID DISCLOSURES:

The names of those who submitted bids will not be made public information unless in conformity with the County Purchasing Act. No pricing or staffing information will be released. Bidders are requested to withhold all inquiries regarding their bid or other submissions until after an award is made. No communication is to be had with any County employee or official, other than the County Purchasing Agent, regarding whether a bid was received. Violations of this provision may result in the rejection of a bid.

34. WITHDRAWAL OF BID:

Bidders may request withdrawal of a sealed bid prior to the scheduled bid opening time provided the request for withdrawal is submitted to the Purchasing Agent in writing. No bids may be withdrawn for a period of sixty (60) calendar days after opening of the bids.

35. INDEMNIFICATION:

The contractor shall agree to assume all risks and responsibility for, and agrees to indemnify, defend, and save harmless, the County of Galveston, its elected and appointed officials and department heads, and its agents and employees from and against all claims, demands, suits, actions, recoveries, judgments, and costs and expenses including reasonable attorney's fees for the defense thereof in connection therewith on account of the loss of life, property or injury or damage to the person which shall arise from contractor's operations under this contract, its use of County facilities and/or equipment or from any other breach on the part of the contractor, its employees, agents or any person(s), in or about the County's facilities with the expressed or implied consent of the County. Contractor shall pay any judgment with cost which may be obtained against Galveston County resulting from contractor's operations under this contract.

Contractor agrees to indemnify and hold the County harmless from all claims of subcontractors, laborers incurred in the performance of this contract. Contractor shall furnish satisfactory evidence that all obligations

**GENERAL PROVISIONS
COMMUNITY CENTER AT 64 ACRE PARK, BA CLIFF, TX
GALVESTON COUNTY, TEXAS**

of this nature herein above designated have been paid, discharged or waived. If Contractor fails to do so, then the County reserves the right to pay unpaid bills of which County has written notice direct and withhold from Contractor's unpaid compensation a sum of money reasonably sufficient to liquidate any and all such lawful claims.

36. REQUIREMENT OF AND PROOF OF INSURANCE:

The successful Bidder shall furnish evidence of insurance to the County Purchasing Agent and shall maintain such insurance as required hereunder or as may be required in the Special Provisions or resultant contract, if different. Contractor shall obtain and thereafter continuously maintain in full force and effect, commercial general liability insurance, including but not limited to bodily injury, property damage, and contractual liability, with combined single limits as listed below or as may be required by State or Federal law, whichever is greater.

- A. For damages arising out of bodily injury to or death of one person in any one accident :
ONE HUNDRED THOUSAND AND NO/100 (\$100,000.00) DOLLARS.
- B. For damages arising out of bodily injury to or death of two or more persons in any one accident:
THREE HUNDRED THOUSAND AND NO/100 (\$300,000.00) DOLLARS.
- C. For any injury to or destruction of property in any one accident :
ONE HUNDRED THOUSAND AND NO/100 (\$100,000.00) DOLLARS.

Insurance shall be placed with insurers having an A.M. Best's rating of no less than A. Such insurance must be issued by a casualty company authorized to do business in the State of Texas, and in standard form approved by the Board of Insurance Commissioners of the State of Texas, with coverage provisions insuring the public from loss or damage that may arise to any person or property by reason of services rendered by Contractor.

Galveston County shall be listed as the additional insured on policy certificates and shall be provided with no less than thirty (30) calendar days prior notice of any changes to the policy during the contractual period.

Certificates of Insurance, fully executed by a licensed representative of the insurance company written or countersigned by an authorized Texas state agency, shall be filed with the County Purchasing Agent within ten (10) business days of issuance of notification from the County Purchasing Agent to Bidder that the contract is being activated as written proof of such insurance and further provided that Bidder shall not commence work under this contract until it has obtained all insurance required herein, provided written proof as required herein, and received written notice to proceed issued from the County Purchasing Agent.

Proof of renewal/replacement coverage shall be provided upon expiration, termination, or cancellation of any policy. Said insurance shall not be cancelled, permitted to expire, or changed without thirty (30) days prior written notice to the County.

Insurance required herein shall be maintained in full force and effect during the life of this contract and shall be issued on an occurrence basis. Contractor shall require that any and all subcontractors that are not protected under the Contractor's own insurance policies take and maintain insurance of the same nature and in the same amounts as required of Contractor and provide written proof of such insurance to Contractor. Proof of renewed/replacement coverage shall be provided upon expiration, termination, or cancellation of any policy. Contractor shall not allow any subcontractor to commence work on the subcontract until such insurance required for the subcontractor has been obtained and approved.

Workers' Compensation Insurance: Successful Bidder shall carry in full force Workers' Compensation Insurance Policy(ies), if there is more than one employee, for all employees, including but not limited to full time, part time, and emergency employees employed by the successful Bidder. Current insurance certificates certifying that such policies as specified above are in full force and effect shall be furnished by successful Bidder to the County.

**GENERAL PROVISIONS
COMMUNITY CENTER AT 64 ACRE PARK, BACLIFF, TX
GALVESTON COUNTY, TEXAS**

Insurance is to be placed with insurers having a Best rating of no less than A. The Bidder shall furnish the County with certificates of insurance and original endorsements affecting coverage required by these insurance clauses within ten (10) business days of receiving notification from the County Purchasing Agent that the contract is being activated.

The certificates and endorsements for each insurance policy are to be signed by a person authorized by the insurer to bind coverage on its behalf. The Bidder shall be required to submit annual renewals for the term of this contract prior to expiration of any policy.

In addition to the remedies stated herein, the County has the right to pursue other remedies permitted by law or in equity.

The County agrees to provide Bidder with reasonable and timely notice of any claim, demand, or cause of action made or brought against the County arising out of or related to utilization of the property. Bidder shall have the right to defend any such claim, demand, or cause of action at its sole cost and expense and within its sole and exclusive discretion. The County agrees not to compromise or settle any claim or cause of action arising out of or related to the utilization of the property without the prior written consent of the Bidder.

In no event shall the County be liable for any damage to or destruction of any property belonging to the Bidder.

37. BID GUARANTEE:

Unless specified differently within the Special Provisions of this procurement, each Bidder shall be required to submit a bid guarantee with its bid as required within this Section.

Evidencing its firm commitment to engage in contract if Bidder is selected for award of contract, each Bidder is required to furnish with their bid a cashier's check or an acceptable Bidder's bond in the amount of five percent (5%) of the total contract price. If Bidder is using a bond, then the Bidder bond must be executed with a surety company authorized to do business in the State of Texas. Failure to furnish the bid guarantee in the proper form and amount, by the time set for opening of bids may be cause for rejection of the bid.

The cashier's check or Bidder/bid bond (as applicable) will be returned to each respective unsuccessful Bidder(s) subsequent to the Commissioners Court award of contract, and shall be returned to the successful Bidder upon the completion and submission of all contract documents. Provided however, that the cashier's check or Bidder bond will be forfeited to the County as liquidated damages should successful Bidder fail to execute the contract within thirty (30) days after receiving notice of the acceptance of its bid.

38. PERFORMANCE AND PAYMENT BONDS:

Successful Bidder, before beginning work, shall execute a performance bond and a payment bond, each of which must be in the amount of the contract. The required payment and performance bonds must each be executed by a corporate surety authorized to write surety bonds in the State of Texas and in accordance with Chapter 3503 of the Insurance Code (codified in 2005 and originally within Section 1, Chapter 87, Acts of the 56th Leg., R.S., 1959, and in Article 7.19-1, Vernon's Texas Insurance Code).

The performance and payment bonds must each clearly and prominently display on the bond or on an attachment to the bond:

- a.) The name, mailing address, physical address, and telephone number, including the area code, of the surety company to which any notice of claim should be sent; or

**GENERAL PROVISIONS
COMMUNITY CENTER AT 64 ACRE PARK, BAACLIFF, TX
GALVESTON COUNTY, TEXAS**

- b.) The toll-free telephone number maintained by the Texas Department of Insurance under Subchapter B, Chapter 521, Insurance Code, and a statement that the address of the surety company to which any notice of claim should be sent may be obtained from the Texas Department of Insurance by calling the toll free-telephone number.

The performance bond shall be solely for the protection of Galveston County, in the amount of the contract, and conditioned on the faithful performance of the work in accordance with the plans, specifications, and contract documents. The payment bond is solely for the protection and use of payment bond beneficiaries who have a direct contractual relationship with the prime contractor or a subcontractor to supply labor or material, and in the amount of the contract.

The payment and performance bonds required to be furnished herein must be furnished before the contractor begins work and are a requirement for issuance of a Notice to Proceed. Such bonds must be furnished to the Galveston County Purchasing Agent within thirty (30) calendar days after the date of the full execution of the contract or, if applicable, as required under Chapter 2253, Government Code, whichever is earlier. Contractor's failure to provide the required payment and performance bonds within such time period shall constitute an event of default under this contract. Contractor shall not commence work until all applicable certificates of insurance, performance bonds, and payment bonds have been received and approved by the County Purchasing Agent and the Contractor receives notice to proceed in writing that has been issued by the County Purchasing Agent.

Additionally, if this request for bid is for the award of a public works contract, then compliance with Chapter 2253 of the Texas Government Code, which is known as the McGregor Act, is mandatory. Performance and payment bonds are required to be furnished in accordance with Chapter 2253 of the Texas Government Code. Bidder should familiarize itself with the entire provisions of Chapter 2253 of the Texas Government Code.

39. PATENT AND COPYRIGHT PROTECTION:

The Bidder agrees at its sole expense to protect the County from claims involving infringement of patents, copyright, trademark, trade secret, or other intellectual property rights. **Bidder shall indemnify and save harmless the County of Galveston, its officers, employees, and agents, from liability of any nature and kind whatsoever, including without limitation cost and expenses, for or on account of any copyrighted, trademarked, trade secret, patented or un-patented invention, process, or article manufactured or used in the performance of the contract, or other intellectual property rights, including its use by the County.** Bidder also agrees that if Bidder is awarded this contract, that no work performed hereunder shall be subject to patent, copyright, or other intellectual property by Bidder.

40. CONFLICT OF INTEREST DISCLOSURE REPORTING (FORM CIQ):

Bidder may be required under Chapter 176 of the Texas Local Government Code to complete and file a conflict of interest questionnaire (CIQ Form). The CIQ Form pertains to business relationship, gift giving and family relationship reporting. IF bidder is required to file a CIQ Form, then the completed CIQ Form must be filed with the County Clerk of Galveston County, Texas.

Business relationship. If Bidder has an employment or other business relationship with a local government officer of Galveston County work with a family member of a local government officer of Galveston County that results in the officer or family member of the officer receiving taxable income that exceeds \$2,500.00 during the preceding 12-month period, then Bidder **MUST** complete a CIQ Form and file the original of the CIQ Form with the County Clerk of Galveston County.

Gift-giving. If Bidder has given a local government officer of Galveston County or a family member of a local government officer of Galveston County one or more gifts with an aggregate value of more than one-hundred dollars

GENERAL PROVISIONS
COMMUNITY CENTER AT 64 ACRE PARK, BAACLIFF, TX
GALVESTON COUNTY, TEXAS

(\$100.00) during the preceding 12-months, then Bidder **MUST** complete a CIQ Form and file the original of the CIQ Form with the County Clerk of Galveston County.

For purposes of the business relationship and gift giving reporting requirements, a “family member” means a person related to another person with the first degree of consanguinity or affinity, as described by Subchapter B, Chapter 573, Texas Government Code. Examples of persons within the first degree by consanguinity or affinity include a son, daughter, father, mother, spouse, son-in-law, daughter-in-law, father-in-law, mother-in-law, stepson, stepdaughter, stepmother, and stepfather.

Family relationship. If Bidder has a “family relationship” with a local government officer of Galveston County then Bidder **MUST** complete a CIQ Form and file the original of the CIQ Form with the County Clerk of Galveston County, regardless of whether Bidder has a business relationship or has given gifts to the local government office or a family member of the local government officer. For this purpose, “family relationship” means Bidder is related within the third degree by consanguinity or the second degree by affinity, as those terms are defined under Chapter 573 of the Texas Government Code, to a local government officer of Galveston County. Examples of such relationships include a son, daughter, mother, father, brother, sister, grandchild, great-grandchild, grandparent, great-grandparent, niece, nephew, uncle, aunt, spouse, mother-in-law, father-in-law, daughter-in-law, son-in-law, spouse’s grandchild, spouse’s grandparent, grandparent’s spouse, grandchild’s spouse, stepson, stepdaughter, stepmother, and stepfather.

Bidder must file its original CIQ Form with the Galveston County Clerk. The Galveston County Clerk has offices at the following locations:

Galveston County Clerk
Galveston County Justice Center, Suite 2001
600 59th Street
Galveston, Texas 77551

Galveston County Clerk
North County Annex, 1st Floor
174 Calder Road
League City, Texas 77573

Again, if Bidder is required to file a 1295 Form, the original completed form is filed with the Galveston County Clerk (not the Purchasing Agent).

For Bidder’s convenience, a blank CIQ Form is enclosed with this bid package. Blank Form 1295’s may also be obtained by visiting the Purchasing Agent’s website – this website is linked from the Galveston County homepage, at <http://www.co.galveston.tx.us>.

As well, blank Form 1295 may be obtained by visiting the Texas Ethics Commission website, specifically at http://www.ethics.state.tx.us/whatsnew/conflict_forms.htm.

Chapter 176 specifies deadlines for the filing of CIQ Forms (both initial filings and updated filings).

It is Bidder’s sole responsibility to file a true and complete CIQ Form with the Galveston County Clerk if Bidder is required to file by the requirements of Chapter 176 of the Local Government Code. Bidder is advised that it is an offense to fail to comply with the disclosure reporting requirements dictated under Chapter 176 of the Texas Local Government Code, and the failure to file may be grounds to void the contract, if Bidder is awarded a contract.

If bidder has any questions about compliance with Chapter 176, Bidder may wish to consult its’ legal counsel. Compliance is the individual responsibility of each person, business, and agent who is subject to Chapter 176 of the Texas Local Government Code.

**GENERAL PROVISIONS
COMMUNITY CENTER AT 64 ACRE PARK, BAACLIFF, TX
GALVESTON COUNTY, TEXAS**

FORM 1295:

Certificate of Interested Parties (Form 1295):

In 2015, the Texas Legislature adopted House Bill 1295, which added section 2252.908 of the Government Code. The law states that a governmental entity or state agency may not enter into certain contracts with a business entity unless the business entity submits a disclosure of interested parties to the governmental entity or state agency at the time the business entity submits the signed contract to the governmental entity or state agency. The law applies only to a contract of a governmental entity or state agency that either (1) requires an action or vote by the governing body of the entity or agency before the contract may be signed or (2) has a value of at least \$1 million. The disclosure requirement applies to a contract entered into on or after January 1, 2016.

The Texas Ethics Commission was required to adopt rules necessary to implement that law, prescribe the disclosure of interested parties form, and post a copy of the form on the commission's website. The commission adopted the Certificate of Interested Parties form (Form 1295) on October 5, 2015. The commission also adopted new rules (Chapter 46) on November 30, 2015, to implement the law.

For Bidder's convenience, a blank Form 1295 is enclosed with this bid package. Blank Form 1295's may also be obtained by visiting the Purchasing Agent's website – this website is linked from the Galveston County homepage, at <http://www.co.galveston.tx.us>.

As well, blank Form 1295 may be obtained by visiting the Texas Ethics Commission website, specifically at http://www.ethics.state.tx.us/whatsnew/conflict_forms.htm.

41. CERTIFICATION REGARDING DEBARMENT, SUSPENSION, PROPOSED DEBARMENT, AND OTHER RESPONSIBILITY MATTERS:

Bidder certifies that neither it, nor any of its Principals, are presently debarred, suspended, proposed for debarment, disqualified, excluded, or in any way declared ineligible for the award of contracts by any Federal agency. Contractor agrees that it shall refund Galveston County for any payments made to Contractor while ineligible. Contractor acknowledges that Contractor's uncured failure to perform under this Agreement, if such should occur, may result in Contractor being debarred from performing additional work for the County, the GLO, the State, HUD, and other Federal and State entities. Further, Bidder has executed the Certification Regarding Debarment, Suspension, Proposed Debarment, and Other Responsibility Matters and returned the fully completed and executed original certification with the submission of its bid. **The truthful and fully completed and executed original of the Certification Regarding Debarment, Suspension, Proposed Debarment, and Other Responsibility Matters must be included with the submission of Bidder's Bid and is a mandatory requirement of this Invitation to Bid. Bidder's failure to include the fully completed and executed original of this Certification shall be considered non-compliance with the requirements of this Invitation to Bid and grounds for the rejection of Bidder's Bid.**

42. NON-COLLUSION AFFIDAVIT:

Bidder certifies, by signing and submitting a bid, that the bid is not made in the interest of, or on behalf of, any undisclosed person, partnership, company, association, organization, or corporation; that the bid is genuine and not collusive or sham; that the contractor has not directly or indirectly induced or solicited another contractor to put in a false or sham bid, and has not directly or indirectly colluded, conspired, connived, or agreed with any contractor or anyone else to put in a sham Bid or that anyone shall refrain from bidding; that the contractor has not in any manner, directly or indirectly, sought by agreement, communications, or conference with anyone to fix the bid price of the contractor of any other bidder, or to fix any overhead, profit or cost element of the bid price, or that of any other contractor, or to secure any advantage against the public body awarding the contract or anyone interested in the proposed contract; that all statements contained in the bid are true; and further, that the contractor has not, directly or indirectly, submitted his or her bid price or any breakdown thereof, or the contents thereof, or divulged information or

**GENERAL PROVISIONS
COMMUNITY CENTER AT 64 ACRE PARK, BACLIF, TX
GALVESTON COUNTY, TEXAS**

data relative thereto, or paid, and will not pay, any fee to any cooperation, partnership, company association, organization, Bid depository, or to any member or agent thereof to effectuate a collusive or sham bid.

A blank Non-Collusion Affidavit is included with this Bid packet. Bidder must enclose a truthful and fully executed original Non-Collusion Affidavit with the submission of its bid. This is a mandatory requirement of this Invitation to Bid. Failure to include the truthfully and fully executed Non-Collusion Affidavit in the submission of its Bid shall be considered non-compliance with the requirements of this Invitation to Bid by the Bidder and grounds for the rejection of Bidder's submission.

No negotiations, decisions, or actions shall be initiated by any company as a result of any verbal discussion with any County employee prior to the opening of responses to this Invitation to Bid.

No officer or employee of the County of Galveston, and no other public or elected official, or employee, who may exercise any function or responsibilities in the review or approval of this undertaking shall have any personal or financial interest, direct or indirect, in any contract or negotiation process thereof. The above compliance request will be part of all County of Galveston contracts for this service.

43. SOVEREIGN IMMUNITY:

The County specifically reserves any claim it may have to sovereign, qualified, or official immunity as a defense to any action arising in conjunction with this contract.

44. CONTROLLING LAW AND VENUE:

Bidder acknowledges and agrees that the contract is and shall be governed and construed by the laws of the State of Texas and that venue shall lie exclusively in Galveston County, Texas.

45. MERGERS, ACQUISITIONS:

The Bidder shall be required to notify the County of any potential for merger or acquisition of which there is knowledge at the time that a bid is submitted.

If subsequent to the award of any contract resulting from this Invitation to Bid the Bidder shall merge or be acquired by another firm, the following documents must be submitted to the County:

- A. Corporate resolutions prepared by the awarded Bidder and the new entity ratifying acceptance of the original contract, terms, conditions and prices;
- B. New Bidder's Federal Identification Number (FEIN) and;
- C. New Bidder's proposed operating plans.

Moreover, Bidder is required to provide the County with notice of any anticipated merger or acquisition as soon as Bidder has actual knowledge of the anticipated merger or acquisition. The New Bidder's proposed plan of operation must be submitted prior to merger to allow time for submission of such plan to the Commissioners' Court for its approval.

46. DELAYS:

The County reserves the right to delay the scheduled commencement date of the contract if it is to the advantage of the County. There shall be no additional costs attributed to these delays should any occur. Bidder agrees it will make no claims for damages, for damages for lost revenues, for damages caused by breach of contract with third parties, or any other claim by Bidder attributed to these delays, should any occur. In addition, Bidder agrees that any contract it enters into with any third party in anticipation of the commencement of the contract will contain a statement that the third party will similarly make no claim for damages based on delay of the scheduled commencement date of the contract.

GENERAL PROVISIONS
COMMUNITY CENTER AT 64 ACRE PARK, BACLIFF, TX
GALVESTON COUNTY, TEXAS

47. ACCURACY OF DATA:

Information and data provided through this Invitation to Bid are believed to be reasonably accurate.

48. SUBCONTRACTING/ASSIGNMENT:

Bidder shall not assign, sell, or otherwise transfer its contract in whole or in part without prior written permission of Commissioners' Court. Such consent, if granted, shall not relieve the Bidder of any of its responsibilities under this contract.

49. INDEPENDENT CONTRACTOR:

Bidder expressly acknowledges that it is an independent contractor. Nothing in this agreement is intended nor shall be construed to create an agency relationship, an employer/employee relationship, a joint venture relationship, or any other relationship allowing County to exercise control or direction over the manner or method by which Bidder or its subcontractors perform in providing the requirements stated in the Invitation to Bid.

50. MONITORING PERFORMANCE:

The County shall have the unfettered right to monitor and audit the Bidder's work in every respect. In this regard, the Bidder shall provide its full cooperation and insure the cooperation of its employees, agents, assigns, and subcontractors. Further, the Bidder shall make available for inspection and/or copying when requested, original data, records, and accounts relating to the Bidder's work and performance under this contract. In the event any such material is not held by the Bidder in its original form, a true copy shall be provided.

51. PROCUREMENT ETHICS:

Galveston County is committed to the highest ethical standards. Therefore, it is a serious breach of the public trust to subvert the public purchasing process by directing purchases to certain favored vendors, or to tamper with the competitive bidding process, whether it's done for kickbacks, friendship or any other reason. Since misuse of the purchasing power of a local government carries criminal penalties, and many such misuses are from a lack of clear guidelines about what constitutes an abuse of office, the Code of Ethics outlined below must be strictly followed.

Galveston County also requires ethical conduct from those who do business with the County.

CODE OF ETHICS – Statement of Purchasing Policy:

Public employment is a public trust. It is the policy of Galveston County to promote and balance the objective of protecting the County's integrity and the objective of facilitating the recruitment and retention of personnel needed by Galveston County. Such policy is implemented by prescribing essential standards of ethical conduct without creating unnecessary obstacles to entering public office.

Public employees must discharge their duties impartially so as to assure fair competitive access to governmental procurement by responsible contractors. Moreover, they should conduct themselves in such a manner as to foster public confidence in the integrity of the Galveston County procurement organization.

To achieve the purpose of this Article, it is essential that those doing business with Galveston County also observe the ethical standards prescribed herein.

General Ethical Standards:

It shall be a breach of ethics to attempt to realize personal gain through public employment with Galveston County by any conduct inconsistent with the proper discharge of the employee's duties.

It shall be a breach of ethics to attempt to influence any public employee of Galveston County to breach the standards of ethical conduct set forth in this code.

**GENERAL PROVISIONS
COMMUNITY CENTER AT 64 ACRE PARK, BAACLIFF, TX
GALVESTON COUNTY, TEXAS**

It shall be a breach of ethics for any employee of Galveston County to participate directly or indirectly in a procurement when the employee knows that:

- The employee or any member of the employee's immediate family, has a financial interest pertaining to the procurement;
- A business or organization in which the employee or any member of the employee's immediate family, has a financial interest pertaining to the procurement; or
- Any other person, business, or organization with which the employee or any member of the employee's immediate family is negotiating or has an arrangement concerning prospective employment is involved in the procurement.

Gratuities:

It shall be a breach of ethics for any person to offer, give, or agree to give any employee or former employee of Galveston County, or for any employee or former employee of Galveston County to solicit, demand, accept or agree to accept from another person, a gratuity or an offer of employment in connection with any decision, approval, disapproval, recommendation, preparation of any part of a program requirement or a purchase request, influencing the content of any specification or procurement standard, rendering of advice, investigation, auditing, or in any other

advisory capacity in any proceeding or application, request for ruling, determination, claim or controversy, or other particular matter, pertaining to any program requirement or a contract or subcontract, or to any solicitation or bid pending before this government.

Kickbacks:

It shall be a breach of ethics for any payment, gratuity or offer of employment to be made by or on behalf of a subcontractor under a contract to the prime contractor or higher tier subcontractor for any contract for Galveston County, or to any person associated therewith, as an inducement for the award of a subcontract or order.

Contract Clause:

The prohibition against gratuities and kickbacks prescribed above shall be conspicuously set forth in every contract and solicitation by Galveston County.

Confidential Information:

It shall be a breach of ethics for any employee or former employee of Galveston County to knowingly use confidential information for actual or anticipated personal gain, or for the actual or anticipated gain of any other person.

Prohibition against Contingent Fees:

It shall be a breach of ethical standards for a person to be retained, or to retain a person, to solicit or secure a Galveston County contract upon an agreement or understanding for a commission, percentage, brokerage, or contingent fee, except for retention of bona fide employees or bona fide established commercial selling agencies for the purpose of securing business. Failure to abide by this section constitutes a breach of ethical standards.

Representation:

Bidder represents and warrants, by signing and submitting its bid, that it has not retained anyone in violation of this section prohibiting contingent fees.

Contract Clause:

The representation prescribed above shall be conspicuously set forth in every contract and solicitation thereof.

GENERAL PROVISIONS
COMMUNITY CENTER AT 64 ACRE PARK, BACLIFF, TX
GALVESTON COUNTY, TEXAS

52. SUBJECT TO APPROPRIATION OF FUNDS:

State law prohibits the obligation and expenditure of public funds beyond the fiscal year for which a budget has been approved by the Commissioners' Court. Galveston County anticipates this to be an integral part of future budgets to be approved during the periods of this contract, except for unanticipated needs or events which may prevent such payments against this contract. However, Galveston County cannot guarantee the availability of funds, and enters into this contract only to the extent such funds are made available through appropriation (allocation) by the Commissioners' Court. This contract shall not be construed as creating any debt on behalf of the County of Galveston in violation of TEX. CONST. art. XI, § 7, and it is understood that all obligations of Galveston County are subject to the availability of funds.

53. NON-DISCRIMINATION:

- A. **Equal Employment Opportunity:** Bidder will not discriminate against any employee or applicant for employment because of race, color, religion, national origin, sex, disability, genetic information or veteran status. Bidder will take affirmative action to ensure that applicants are employed, and that employees are treated during employment, without regard to their race, color, religion, national origin, sex, disability, genetic information or veteran status. Such action shall include, but not be limited to, the following: employment; upgrading; demotion or transfer; recruitment or recruitment advertising; layoff or termination; rates of pay or other forms of compensation; and selection for training, including apprenticeship. Bidder agrees to post in conspicuous places, available to employees and applicants for employment, notices of employment.

Bidder will, in all solicitation or advertisements for employees placed by or on behalf of Bidder, state that all qualified applicants will receive consideration for employment without regard to race, color, religion, national origin, sex, disability, genetic information, or veteran status.

Bidder will cause the foregoing provisions to be inserted in all subcontracts for any work covered by this Agreement so that such provisions will be binding upon each subcontractor, provided that the foregoing provisions shall not apply to contracts or subcontracts for standard commercial supplies or raw materials.

Bidder will include the provisions herein in every subcontract or purchase order unless exempted.

- B. **Drug Free Work Place Act:** Bidder shall comply with all applicable requirements of the Drug-Free Workplace Act of 1988 and implementing regulations.
- C. **Americans with Disabilities Act:** Bidder shall comply with all applicable provisions of the Americans with Disabilities Act and implementing regulations.
- D. **OSHA Regulations:** Bidder agrees to maintain and to display any applicable materials for its employees in accordance with OSHA regulations.
- E. **Compliance with Immigration Laws and Use of E-Verify:** Bidder agrees to comply with all requirements of the U.S. Immigration Reform and Control Act of 1986, as amended, and any implementing regulations thereto. Bidder further agrees to utilize the E-Verify system through the Department of Homeland Security on its employees. Bidder shall not employ unauthorized aliens, and shall not assign services to be performed to any supplier or subcontractor who are unauthorized aliens. If any personnel performing any services hereunder are discovered to be an unauthorized alien, then Bidder will immediately remove such personnel from performing services hereunder and shall replace such personnel with personnel who are not unauthorized alien(s).

GENERAL PROVISIONS
COMMUNITY CENTER AT 64 ACRE PARK, BACLIF, TX
GALVESTON COUNTY, TEXAS

- F. State and Federal Law Compliance: Bidder agrees to comply with all other State and Federal laws and regulations applicable to the provision of services under this contract.

54. RECORD RETENTION AND RIGHT TO AUDIT:

Bidder shall keep and maintain all records associated with this contract for a minimum of five (5) years from the close of the contract or as required by Federal or State law or regulation, whichever period is longer. If awarded this contract, Bidder shall allow the County reasonable access to the records in Bidder's possession, custody, or control that the County deems necessary to assist it in auditing the services, costs, and payments provided hereunder. If this contract involves the use of Federal or State funds, then Bidder shall also allow reasonable access to representatives of the Office of Inspector General, the General Accounting Office, and the other Federal and/or State agencies overseeing the funds that such entities deem necessary to facilitate review by such agencies and Bidder shall maintain fiscal records and supporting documentation for all expenditures in a manner that conforms with OMB Circular A-87 (relocated to 2 C.F.R. Part 225) and this contract.

55. TITLE VI ASSURANCES/TxDOT:

The County is subject to Title VI of the Civil Rights Act of 1964 and the Federal and State laws and regulations of the United States Department of Transportation and Texas Department of Transportation (TxDOT). Pursuant to these requirements, the County must have its contractors provide required assurances on compliance with non-discrimination by itself and its subcontractors. The Title VI Assurances within this Subsection are not exhaustive – whenever any Federal, State, or Local requirement requires additional clauses, this list shall not be construed as limiting. Contractor agrees as follows:

- A. **Compliance with Regulations:** The Contractor shall comply with the Regulations relative to nondiscrimination in Federally-assisted programs of the Department of Transportation (hereinafter, DOT)

Title 49, Code of Federal Regulations, Part 21, as they may be amended from time to time (hereinafter referred to as the Regulations), which are incorporated herein by reference and made a part of this contract.

- B. **Non-discrimination:** The Contractor, with regard to the work performed by it during the contract, shall not discriminate on the basis of race, color, national origin, religion, sex, age, disability or Veteran status in the selection and retention of subcontractors, including procurements of materials and leases of equipment. The Contractor shall not participate either directly or indirectly in the discrimination prohibited by Section 21.5 of the Regulations, including employment practices when the contract covers a program set forth in Appendix B of the Regulations.
- C. **Solicitations for Subcontractors, Including Procurement of Materials and Equipment:** In all solicitations either by competitive bidding or negotiation made by the Contractor for work to be performed under a subcontract, including procurement of materials or leases of equipment, each potential subcontractor or supplier shall be notified by the Contractor of the Contractor's obligations under this contract and the Regulations relative to nondiscrimination on the grounds of race, color, national origin, religion, sex, age, disability or Veteran status.
- D. **Information and Reports:** The Contractor shall provide all information and reports required by the Regulations or directives issued pursuant thereto, and shall permit access to its books, records, accounts, other sources of information and its facilities as may be determined by the Galveston County or the Texas Department of Transportation to be pertinent to ascertain compliance with such Regulations, orders and instructions. Where any information required of the Contractor is in the exclusive possession of another who fails or refuses to furnish this information the Contractor shall so certify to Galveston County or the Texas Department of Transportation as appropriate, and shall set forth what efforts it has made to obtain the information.

GENERAL PROVISIONS
COMMUNITY CENTER AT 64 ACRE PARK, BACLIFF, TX
GALVESTON COUNTY, TEXAS

E. **Sanctions for Non-compliance:** In the event of the Contractor's noncompliance with the nondiscrimination provisions of this contract, Galveston County shall impose such contract sanctions as it or the Texas Department of Transportation may determine to be appropriate, including, but not limited to:

- 1) withholding of payments to the Contractor under the contract until the Contractor complies, and/or;
- 2) cancellation, termination, or suspension of the contract, in whole or in part.

F **Incorporation of Provisions.** The Contractor shall include the provisions of paragraphs (1) through (6) in every subcontract, including procurement of materials and leases of equipment, unless exempt by the Regulations, or directives issued pursuant thereto. The Contractor shall take such action with respect to any subcontract or procurement as Galveston County or the Texas Department of Transportation may direct as a means of enforcing such provisions including sanctions for non-compliance: Provided, however, that, in the event Contractor becomes involved in, or is threatened with, litigation with a subcontractor or supplier as a

result of such direction, the Contractor may request Galveston County to enter into such litigation to protect the interests of Galveston County, and, in addition, the Contractor may request the United States to enter into such litigation to protect the interests of the United States.

56. SECTION 231.006, FAMILY CODE/DELINQUENT CHILD SUPPORT:

Pursuant to Title 5, Section 231.006 of the Texas Family Code, as applicable, Bidder certifies that it, including all of its principals, is/are current in child support payments and therefore, that it is eligible to receive payments from State funds under a contract for property, materials, or services. Bidder acknowledges and agrees that if it is awarded this contract, then the ensuing agreement may be terminated and payment withheld if this certification is inaccurate. Finally, by the submission of its bid, the Bidder certifies that it has included the names and social security numbers of each person with at least 25% ownership interest in Bidder within its response to the Invitation to Bid and that all such persons are current in child support payments.

57. ANTITRUST:

Pursuant to 15 U.S.C. § 1, et seq., and Texas Business and Commerce Code, Chapter 15, Contractor, by the submission of its bidl, certifies that neither Contractor nor any natural person, proprietorship, firm, corporation, partnership, association, or institution represented by Contractor or anyone acting for such natural person, proprietorship, firm, corporation, partnership, association, or institution has violated any Federal or State antitrust laws or communicated the nature of the offer, directly or indirectly, to any competitor or other person engaged in a similar line of business.

58. LABOR STANDARDS:

Bidder acknowledges that the contract to be awarded pursuant to this solicitation is on a grant program funded with Federal funds. Bidder shall comply with the requirements of 29 CFR Part 5 and CFR Part 30 and shall be in conformity with Executive Order 11246, entitled "Equal Employment Opportunity", Copeland, "Anti-Kickback" Act (29 C.F.R. Part 3), the Davis-Bacon and Related Acts (29 C.F.R. Parts 1,3, and 5), the Contract Work Hours and Safety Standards Act (40 U.S.C. 3701 et seq.), and all other applicable Federal, State, and local laws and regulations pertaining to labor standards, insofar as those acts apply to the performance of this Agreement. Bidder is also responsible for ensuring that all subcontractors comply with the requirements of 29 CFR Part 5 and CFR Part 30 and shall be in conformity with Executive Order 11246, entitled "Equal Employment Opportunity", Copeland "Anti-Kickback" Act, the Davis-Bacon and Related Acts (29 CFR Parts 1, 3 and 5), the Contract Work Hours and Safety Standards Act (40 U.S.C. 3701 et seq.), and all other applicable Federal, State, and local laws and regulations pertaining to labor standards, insofar as those acts apply to the performance of this Agreement.

59. ENTIRETY OF AGREEMENT AND MODIFICATION:

**GENERAL PROVISIONS
COMMUNITY CENTER AT 64 ACRE PARK, BACLIFF, TX
GALVESTON COUNTY, TEXAS**

This contract contains the entire agreement between the parties. Any prior agreement, promise, negotiation or representation not expressly set forth in this contract has no force or effect. Any subsequent modification to this contract must be in writing, signed by both parties.

An official representative, employee, or agent of the County does not have the authority to modify or amend this contract except pursuant to specific authority to do so granted by the Galveston County Commissioners' Court

60. NOTICE:

All notices or other communications required or permitted under this contract shall be in writing and shall be deemed to have been duly given if delivered personally in hand, transmitted by facsimile, or mailed certified mail, return receipt requested with proper postage affixed and addressed to the appropriate party at the following address or at such other address as may have been previously given in writing to the parties (Bidder shall provide its notice information with its Bid submission). If mailed, the notice shall be deemed delivered when actually received, or if earlier, on the third day following deposit in a United States Postal Service post office or receptacle, duly certified, return receipt requested, with proper postage affixed. If delivered in person, notice shall be deemed delivered when receipted for by, or actually received by, the receiving Party. If transmitted by facsimile, notice shall be deemed delivered when receipt of such transmission is acknowledged.

To the County at:

Hon. Mark Henry,
County Judge of Galveston County
722 Moody (21st Street), Second (2nd) Floor
Galveston, Texas 77550
Fax: (409) 765-2653

With copies to:

Rufus Crowder, CPPO CPPB,
Galveston County Purchasing Agent
722 Moody (21st Street), Fifth (5th) Floor
Galveston, Texas 77550
Fax: (409) 621-7997

Robert Boemer, Director,
Galveston County Legal Department
722 Moody (21st Street), Fifth (5th) Floor
Galveston, Texas 77550
Fax: (409) 770-5560

To the Contractor at:

(Bidder to provide its contact name, address, and facsimile number for notice hereunder.)

End of General Provision Section

**GENERAL PROVISIONS
COMMUNITY CENTER AT 64 ACRE PARK, BACLIF, TX
GALVESTON COUNTY, TEXAS**

The remainder of this page intentionally left blank

BID FORM
COMMUNITY CENTER AT 64 ACRE PARK, BACLIFF, TX
COUNTY OF GALVESTON, TEXAS

By signing here, the firm does hereby attest that it has fully read the instructions, conditions and general and special provisions and understands them.

EXCEPTIONS (if no exceptions are taken, state NONE):

THE COMPANY OF: _____

ADDRESS: _____

FEIN (TAX ID): _____

The following shall be returned with your bid. Failure to do so may be ample cause for rejection of bid as non-responsive. It is the responsibility of the Bidder to ensure that bidder has received all addenda.

Items:	Confirmed (X):
1. References (if required)	_____
2. Addenda, if any	#1_____ #2_____ #3_____ #4_____
3. One (1) original and five (5) copies of submittal	_____
4. Bid Form	_____
5. Vendor Qualification Packet	_____
6. Debarment Certification Form	_____
7. Non-Collusion Affidavit	_____
8. Form CIQ	_____
9. Payment Terms:	_____ net 30 _____ Other

Person to contact regarding this bid: _____

Title: _____ Phone: _____ Fax: _____

E-mail address: _____

Name of person authorized to bind the Firm: _____

Signature: _____ Date: _____

Title: _____ Phone: _____ Fax: _____

E-mail address: _____

BID FORM
COMMUNITY AT 64 ACRE PARK, BAACLIFF, TX
GALVESTON COUNTY, TEXAS

Bidder shall use this form to provide the information for notice.

1. Contact information for notice:

Name: _____
Address: _____

Telephone Number: _____ Facsimile number: _____

2. If a copy of notice is requested, please complete below:

Name: _____
Address: _____

Telephone Number: _____ Facsimile number: _____

3. If second or more copies are requested for notice, please supplement this form and clearly mark the supplement as "Supplementary Notice Information."

Bidder to submit reference information. Bidder shall use this form to provide minimum required reference information. If Bidder wishes to provide more than the minimum, Bidder should supplement this form and should clearly mark the supplement as "Supplementary Reference Information."

1. References who can attest to the Bidder's capability to carry out the requirements set forth in this bid:

Business Name of Organization: _____
Name of Person: _____
Title of Individual within Organization, if applicable _____
Business address: _____

Telephone number: _____ Facsimile number: _____

Business Name of Organization: _____
Name of Person: _____
Title of Individual within Organization, if applicable _____
Business address: _____

Telephone number: _____ Facsimile number: _____

Business Name of Organization: _____
Name of Person: _____
Title of Individual within Organization, if applicable _____
Business address: _____

Telephone number: _____ Facsimile number: _____

BID FORM
COMMUNITY CENTER AT 64 ACRE PARK, BACLIFF, TX
GALVESTON COUNTY, TEXAS

References of major supplier of Bidder who can speak to the financial capability of the Bidder to carry out the requirements set forth in this bid:

1. Business Name of Supplier _____
Name of Person: _____
Title of Individual within business: _____
Business address: _____

Telephone number: _____ Facsimile number: _____

2. Business Name of Supplier _____
Name of Person: _____
Title of Individual within business: _____
Business address: _____

Telephone number: _____ Facsimile number: _____

3. Business Name of Supplier _____
Name of Person: _____
Title of Individual within business: _____
Business address: _____

Telephone number: _____ Facsimile number: _____

The remainder of this page intentionally left blank

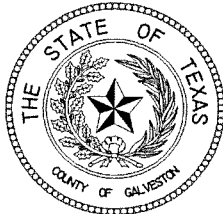

County of Galveston
ACKNOWLEDGMENT AND CERTIFICATION REGARDING DEBARMENT,
SUSPENSION, AND OTHER INELIGIBLE
Executive Orders 12549 & 12689 Certification, Debarment and Suspension

Solicitation Number: BID #B161012A

Solicitation Title: COMMUNITY CENTER AT 64 ACRE PARK, BACLIFF, TX

Contractor hereby CERTIFIES that:

Contractor, and all of its principals, is not presently debarred, suspended, proposed for debarment, proposed for suspension, or declared ineligible under Executive Order 12549 or Executive Order 12689, Debarment and Suspension, and is not in any other way ineligible for participation in Federal or State assistance programs;

Contractor, and all of its principals, were not and have not been debarred, suspended, proposed for debarment, proposed for suspension, or declared ineligible under Executive Order 12549 or Executive Order 12689, Debarment and Suspension, and were not and have not been in any other way ineligible for participation in Federal or State assistance programs at the time its' proposal was submitted in the procurement identified herein and at any time since submission of its' proposal;

Contractor has included, and shall continue to include, this certification in all contracts between itself and any sub-contractors in connection with services performed under this contract; **and**

Contractor shall notify Galveston County in writing immediately, through written notification to the Galveston County Purchasing Agent, if Contractor is not in compliance with Executive Order 12549 or 12689 during the term of its contract with Galveston County.

Contractor **Represents** and **Warrants** that the individual executing this Acknowledgment and Certification on its behalf has the full power and authority to do so and can legally bind the Contractor hereto.

Name of Business

Date

By: _____
Signature

Printed Name & Title

State of Texas

§
§
§

County of Galveston

NON-COLLUSION AFFIDAVIT

Before me, the undersigned notary, on this day personally appeared _____ (Affiant), whom being first duly sworn, deposes and certifies that:

- Affiant is the _____ of _____, that
(Individual, Partner, Corporate Officer) (Name of Proposer)
- submitted the attached Bid/Proposal in **Bid #B161012A Community Center at 64 Acre Park, Bacliff, TX**
- Affiant is a duly authorized representative of Proposer and is authorized to make this Non-Collusion Affidavit;
- The attached Proposal/Bid is genuine and is not a collusive or sham Proposal/Bid;
- The attached Proposal/Bid has been independently arrived at without collusion with any other bidder, proposer, person, firm, competitor, or potential competitor;
- Bidder/Proposer has not colluded, conspired, connived or agreed, directly or indirectly, with any other bidder, proposer, person, firm, competitor, or potential competitor, to submit a collusive or sham bid or that such other bidder, proposer, person, firm, competitor, or potential competitor shall refrain from bidding/proposing;
- Bidder/Proposer has not in any manner, directly or indirectly, sought by agreement or collusion or communication or conference with any other bidder, proposer, person, firm, competitor, or potential competitor to fix the price or prices in the attached Bid/Proposal or of the bid/proposal any other bidder/proposer;
- Bidder/Proposer has not in any manner, directly or indirectly, sought by agreement or collusion or communication or conference with any other bidder, proposer, person, firm, competitor, or potential competitor to fix the overhead, profit or cost element of the Bid/Proposal price or prices of any other bidder/proposer, or to secure through any collusion, conspiracy, connivance, or unlawful agreement any advantage against Galveston County or any person interested in the proposed contract;
- Affiant has not in any manner, directly or indirectly, sought by agreement or collusion or communication or conference with any other bidder, proposer, person, firm, competitor, or potential competitor, paid or agreed to pay any other bidder, proposer, person, firm, competitor, or potential competitor any money or anything of value in return for assistance in procuring or attempting to procure a contract or in return for establishing the price or prices in the attached Bid/Proposal or the bid/proposal of any other Bidder/Proposer; and
- Affiant certifies that Affiant is fully informed regarding the accuracy of the statements contained herein, and under penalties of perjury, certifies and affirms the truth of the statements herein, such penalties being applicable to the Bidder/Proposer as well as to Affiant signing on its behalf.

Signature of Affiant

SWORN TO and SUBSCRIBED before me this _____ day of _____, 2016 .

Notary Public

My Commission Expires: _____

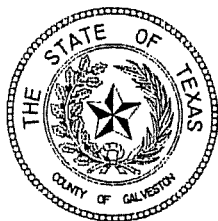

County of Galveston Purchasing Department Vendor Qualification Packet

(rev. 1.2, March 29, 2010)

All interested parties seeking consideration for qualified vendor status with the County of Galveston should complete and return only the following attached forms to:

Galveston County Purchasing Department
722 Moody Avenue, (21st Street), 5th Floor
Galveston, Texas 77550
(409) 770-5371 office
(409) 621-7987 fax

- Form PEID:** Person /Entity Information Data
Form W-9: Request for Taxpayer Identification Number and Certification
(please note that the included form may not be the latest revised form issued by the Internal Revenue Service. Please check the IRS website at <http://www.irs.gov/pub/irs-pdf/fw9.pdf> for the latest revision of this form.)
Form CIQ: Conflict of Interest Questionnaire
(please note that the included form may not be the latest revised form issued by the State of Texas Ethics Commission. Please check the Texas Ethics Commission website at for the latest revision of this form. Please note that Galveston County Purchasing Agent is not responsible for the filing of this form with the Galveston County Clerk per instructions of the State of Texas Ethics Commission).

Certificate(s) of Insurance: If the person or entity seeking qualified vendor status with the County will be performing work at or on any County owned facility and/or property, Certificate(s) of Insurance are required to be submitted prior to performing any work.

Insurance requirements are as follows:

Public Liability and Property Damage Insurance:

Successful vendor agrees to keep in full force and effect, a policy of public liability and property damage insurance issued by a casualty company authorized to do business in the State of Texas, and in standard form approved by the Board of Insurance Commissioners of the State of Texas, with coverage provisions insuring the public from any loss or damage that may arise to any person or property by reason of services rendered by vendor. Vendor shall at its own expense be required to carry the following minimum insurance coverages:

- For damages arising out of bodily injury to or death of one person in any one occurrence – one hundred thousand and no/100 dollars (\$100,000.00);
- For damages arising out of bodily injury to or death of two or more persons in any one occurrence – three hundred thousand and no/100 dollars (\$300,000.00); and
- For injury to or destruction of property in any one occurrence – one hundred thousand and no/100 dollars (\$100,000.00).

This insurance shall be either on an occurrence basis or on a claims made basis. Provided however, that if the coverage is on a claims made basis, then the vendor shall be required to purchase, at the termination of this agreement, tail coverage for the County for the period of the County's relationship with the vendor under this agreement. Such coverage shall be in the amounts set forth in subparagraphs (1), (2), and (3) above.

Worker's Compensation Insurance:

Successful vendor shall also carry in full force Workers' Compensation Insurance policy(ies), if there is more than one employee, for all employees, including but not limited to full time, part time, and emergency employees employed by the vendor. Current insurance certificates certifying that such policies as specified above are in full force and effect shall be furnished by the vendor to the County.

The County of Galveston shall be named as additional insured on policies listed in subparagraphs above and shall be notified of any changes to the policy(ies) during the contractual period. Insurance is to be placed with insurers having a Best rating of no less than A. The vendor shall furnish the County with certificates of insurance and original endorsements affecting coverage required by these insurance clauses. The certificates and endorsements for each insurance policy are to be signed by a person authorized by the insurer to bind coverage on its behalf. The vendor shall be required to submit annual renewals for the term of any contractual agreement, purchase order or term contract, with Galveston County prior to expiration of any policy.

In addition to the remedies stated herein, the County has the right to pursue other remedies permitted by law or in equity.

The County agrees to provide vendor with reasonable and timely notice of any claim, demand, or cause of action made or brought against the County arising out of or related to utilization of the property. Vendor shall have the right to defend any such claim, demand, or cause of action at its sole cost and expense and within its sole and exclusive discretion. The County agrees not to compromise or settle any claim or cause of action arising out of or related to the utilization of the property without the prior written consent of the vendor.

In no event shall the County be liable for any damage to or destruction of any property belonging to the vendor unless specified in writing and agreed upon by both parties.

Procurement Policy - Special Note:

Understand that it is, according to Texas Local Government Code, Section 262.011, Purchasing Agents, subsections (d), (e), and (f), the sole responsibility of the Purchasing Agent to supervise all procurement transactions.

Therefore, be advised that all procurement transactions require proper authorization in the form of a Galveston County purchase order from the Purchasing Agent's office prior to commitment to deliver supplies, materials, equipment, including contracts for repair, service, and maintenance agreements. Any commitments made without proper authorization from the Purchasing Agent's office, pending Commissioners' Court approval, may become the sole responsibility of the individual making the commitment including the obligation of payment.

Code of Ethics - Statement of Purchasing Policy:

Public employment is a public trust. It is the policy of Galveston County to promote and balance the objective of protecting the County's integrity and the objective of facilitating the recruitment and

retention of personnel needed by Galveston County. Such policy is implemented by prescribing essential standards of ethical conduct without creating unnecessary obstacles to entering public office.

Public employees must discharge their duties impartially so as to assure fair competitive access to governmental procurement by responsible contractors. Moreover, they should conduct themselves in such a manner as to foster public confidence in the integrity of the Galveston County procurement organization.

To achieve the purpose of these instructions, it is essential that those doing business with Galveston County also observe the ethical standards prescribed here.

General Ethical Standards: It shall be a breach of ethics to attempt to realize personal gain through public employment with Galveston County by any conduct inconsistent with the proper discharge of the employee's duties.

It shall be a breach of ethics to attempt to influence any public employee of Galveston County to breach the standards of ethical conduct set forth in this code.

It shall be a breach of ethics for any employee of Galveston County to participate directly or indirectly in procurement when the employee knows that:

- The employee or any member of the employee's immediate family has a financial interest pertaining to the procurement.
- A business or organization in which the employee, or any member of the employee's immediate family, has a financial interest pertaining to the procurement.
- Any other person, business or organization with which the employee or any member of the employee's immediate family is negotiating or has an arrangement concerning prospective employment is involved in the procurement.

Gratuities: It shall be a breach of ethics to offer, give or agree to give any employee of Galveston County, or for any employee or former employee of Galveston County to solicit, demand, accept or agree to accept from another person, a gratuity or an offer of employment in connection with any decision, approval, disapproval, recommendation, preparation of any part of a program requirement or purchase request, influencing the content of any specification or procurement standard, rendering of advice, investigation, auditing, or in any other advisory capacity in any program requirement or a contract or subcontract, or to any solicitation or proposal therefore pending before this government.

Kickbacks: It shall be a breach of ethics for any payment, gratuity or offer of employment to be made by or on behalf of a subcontractor under a contract to the prime contractor or higher tier subcontractor for any contract for Galveston County, or any person associated therewith, as an inducement for the award of a subcontract or order.

Contract Clause: The prohibition against gratuities and kickbacks prescribed above shall be conspicuously set forth in every contract and solicitation by Galveston County.

Confidential Information: It shall be a breach of ethics for any employee or former employee of Galveston County to knowingly use confidential information for actual or anticipated personal gain, or for the actual or anticipated gain of any person.

Questions/Concerns:

If you have any questions or concerns regarding the information or instructions contained within this packet, please contact any member of the Purchasing Department staff at (409) 770-5371.

CONFLICT OF INTEREST DISCLOSURE REPORTING

Proposer may be required under Chapter 176 of the Texas Local Government Code to complete and file a conflict of interest questionnaire (CIQ Form). If so, the completed CIQ Form must be filed with the County Clerk of Galveston County, Texas.

If Proposer has an employment or other business relationship with an officer of Galveston County or with a family member of an officer of Galveston County that results in the officer or family member of the officer receiving taxable income that exceeds \$2,500.00 during the preceding 12-month period, then Proposer **MUST** complete a CIQ Form and file the original of the CIQ Form with the County Clerk of Galveston County.

If Proposer has given an officer of Galveston County or a family member of an officer of Galveston County one or more gifts with an aggregate value of more than \$250.00 during the preceding 12-months, then Proposer **MUST** complete a CIQ Form and file the original of the CIQ Form with the County Clerk of Galveston County.

The Galveston County Clerk has offices at the following locations:

Galveston County Clerk
Galveston County Justice Center, Suite 2001
600 59th Street
Galveston, Texas 77551

Galveston County Clerk
North County Annex, 1st Floor
174 Calder Road
League City, Texas 77573

Again, if Proposer is required to file a CIQ Form, the original completed form is filed with the Galveston County Clerk (not the Purchasing Agent).

For Proposer's convenience, a blank CIQ Form is enclosed with this proposal. Blank CIQ Forms may also be obtained by visiting the Galveston County Clerk's website and/or the Purchasing Agent's website – both of these web sites are linked to the Galveston County homepage, at <http://www.co.galveston.tx.us>.

As well, blank CIQ Forms may be obtained by visiting the Texas Ethics Commission website, specifically at http://www.ethics.state.tx.us/whatsnew/conflict_forms.htm.

Chapter 176 specifies deadlines for the filing of CIQ Forms (both initial filings and updated filings).

It is Proposer's sole responsibility to file a true and complete CIQ Form with the Galveston County Clerk if Proposer is required to file by the requirements of Chapter 176. Proposer is advised that it is an offense to fail to comply with the disclosure reporting requirements dictated under Chapter 176 of the Texas Local Government Code.

If you have questions about compliance with Chapter 176, please consult your own legal counsel. Compliance is the individual responsibility of each person, business, and agent who is subject to Chapter 176 of the Texas Local Government Code.

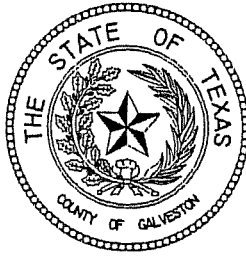

**COUNTY of GALVESTON
Purchasing Department**

rev. 1.3, March 29, 2010

FORM PEID:	Request for Person-Entity Identification Data
-------------------	--

Instructions: Please type or print clearly when completing sections 1 thru 4 and return completed form to:

Galveston County Purchasing Agent
722 Moody Avenue (21st. Street), 5th Floor
Galveston, Texas 77550
(409) 770-5371 office
(409) 621-7987 fax

1.

Business Name:			
Attention Line:			

2.

Physical Address:			
City:		State:	Zip+4:

3.

Billing / Remit Address:			
City:		State:	Zip+4

4.

Main Contact Person:			
Main Phone Number:			
Fax Number:			
E-mail Address:			

Areas below are for County use only.

Requested By:	Phone / Ext. #
Department:	Date:

Action Requested - Check One:	IFAS PEID Vendor Number:	
<input type="checkbox"/> Add New	<input type="checkbox"/> Change Data	<input type="checkbox"/> Re-activate
<input type="checkbox"/> Inactivate	<input type="checkbox"/> Employee	<input type="checkbox"/> Attorney
<input type="checkbox"/> Landlord	<input type="checkbox"/> Foster Parent	<input type="checkbox"/> Refund
<input type="checkbox"/> One Time	<input type="checkbox"/> Foster Child	

Request for Taxpayer Identification Number and Certification

Give form to the
requester. Do not
send to the IRS.

Print or type
See Specific Instructions on page 2.

Name (as shown on your income tax return)	
Business name, if different from above	
Check appropriate box: <input type="checkbox"/> Individual/Sole proprietor <input type="checkbox"/> Corporation <input type="checkbox"/> Partnership <input type="checkbox"/> Limited liability company. Enter the tax classification (D=disregarded entity, C=corporation, P=partnership) ▶ <input type="checkbox"/> Exempt payee <input type="checkbox"/> Other (see instructions) ▶	
Address (number, street, and apt. or suite no.)	Requester's name and address (optional)
City, state, and ZIP code	
List account number(s) here (optional)	

Part I Taxpayer Identification Number (TIN)

Enter your TIN in the appropriate box. The TIN provided must match the name given on Line 1 to avoid backup withholding. For individuals, this is your social security number (SSN). However, for a resident alien, sole proprietor, or disregarded entity, see the Part I Instructions on page 3. For other entities, it is your employer identification number (EIN). If you do not have a number, see *How to get a TIN* on page 3.

Note. If the account is in more than one name, see the chart on page 4 for guidelines on whose number to enter.

Social security number
or
Employer identification number

Part II Certification

Under penalties of perjury, I certify that:

1. The number shown on this form is my correct taxpayer identification number (or I am waiting for a number to be issued to me), and
2. I am not subject to backup withholding because: (a) I am exempt from backup withholding, or (b) I have not been notified by the Internal Revenue Service (IRS) that I am subject to backup withholding as a result of a failure to report all interest or dividends, or (c) the IRS has notified me that I am no longer subject to backup withholding, and
3. I am a U.S. citizen or other U.S. person (defined below).

Certification Instructions. You must cross out item 2 above if you have been notified by the IRS that you are currently subject to backup withholding because you have failed to report all interest and dividends on your tax return. For real estate transactions, item 2 does not apply. For mortgage interest paid, acquisition or abandonment of secured property, cancellation of debt, contributions to an individual retirement arrangement (IRA), and generally, payments other than interest and dividends, you are not required to sign the Certification, but you must provide your correct TIN. See the Instructions on page 4.

Sign Here

Signature of
U.S. person ▶

Date ▶

General Instructions

Section references are to the Internal Revenue Code unless otherwise noted.

Purpose of Form

A person who is required to file an information return with the IRS must obtain your correct taxpayer identification number (TIN) to report, for example, income paid to you, real estate transactions, mortgage interest you paid, acquisition or abandonment of secured property, cancellation of debt, or contributions you made to an IRA.

Use Form W-9 only if you are a U.S. person (including a resident alien), to provide your correct TIN to the person requesting it (the requester) and, when applicable, to:

1. Certify that the TIN you are giving is correct (or you are waiting for a number to be issued),
2. Certify that you are not subject to backup withholding, or
3. Claim exemption from backup withholding if you are a U.S. exempt payee. If applicable, you are also certifying that as a U.S. person, your allocable share of any partnership income from a U.S. trade or business is not subject to the withholding tax on foreign partners' share of effectively connected income.

Note. If a requester gives you a form other than Form W-9 to request your TIN, you must use the requester's form if it is substantially similar to this Form W-9.

Definition of a U.S. person. For federal tax purposes, you are considered a U.S. person if you are:

- An individual who is a U.S. citizen or U.S. resident alien,
- A partnership, corporation, company, or association created or organized in the United States or under the laws of the United States,
- An estate (other than a foreign estate), or
- A domestic trust (as defined in Regulations section 301.7701-7).

Special rules for partnerships. Partnerships that conduct a trade or business in the United States are generally required to pay a withholding tax on any foreign partners' share of income from such business. Further, in certain cases where a Form W-9 has not been received, a partnership is required to presume that a partner is a foreign person, and pay the withholding tax. Therefore, if you are a U.S. person that is a partner in a partnership conducting a trade or business in the United States, provide Form W-9 to the partnership to establish your U.S. status and avoid withholding on your share of partnership income.

The person who gives Form W-9 to the partnership for purposes of establishing its U.S. status and avoiding withholding on its allocable share of net income from the partnership conducting a trade or business in the United States is in the following cases:

- The U.S. owner of a disregarded entity and not the entity,

- The U.S. grantor or other owner of a grantor trust and not the trust, and
- The U.S. trust (other than a grantor trust) and not the beneficiaries of the trust.

Foreign person. If you are a foreign person, do not use Form W-9. Instead, use the appropriate Form W-8 (see Publication 515, Withholding of Tax on Nonresident Aliens and Foreign Entities).

Nonresident alien who becomes a resident alien. Generally, only a nonresident alien individual may use the terms of a tax treaty to reduce or eliminate U.S. tax on certain types of income. However, most tax treaties contain a provision known as a "saving clause." Exceptions specified in the saving clause may permit an exemption from tax to continue for certain types of income even after the payee has otherwise become a U.S. resident alien for tax purposes.

If you are a U.S. resident alien who is relying on an exception contained in the saving clause of a tax treaty to claim an exemption from U.S. tax on certain types of income, you must attach a statement to Form W-9 that specifies the following five items:

1. The treaty country. Generally, this must be the same treaty under which you claimed exemption from tax as a nonresident alien.
2. The treaty article addressing the income.
3. The article number (or location) in the tax treaty that contains the saving clause and its exceptions.
4. The type and amount of income that qualifies for the exemption from tax.
5. Sufficient facts to justify the exemption from tax under the terms of the treaty article.

Example. Article 20 of the U.S.-China Income tax treaty allows an exemption from tax for scholarship income received by a Chinese student temporarily present in the United States. Under U.S. law, this student will become a resident alien for tax purposes if his or her stay in the United States exceeds 5 calendar years. However, paragraph 2 of the first Protocol to the U.S.-China treaty (dated April 30, 1984) allows the provisions of Article 20 to continue to apply even after the Chinese student becomes a resident alien of the United States. A Chinese student who qualifies for this exception (under paragraph 2 of the first protocol) and is relying on this exception to claim an exemption from tax on his or her scholarship or fellowship income would attach to Form W-9 a statement that includes the information described above to support that exemption.

If you are a nonresident alien or a foreign entity not subject to backup withholding, give the requester the appropriate completed Form W-8.

What is backup withholding? Persons making certain payments to you must under certain conditions withhold and pay to the IRS 28% of such payments. This is called "backup withholding." Payments that may be subject to backup withholding include interest, tax-exempt interest, dividends, broker and barter exchange transactions, rents, royalties, nonemployee pay, and certain payments from fishing boat operators. Real estate transactions are not subject to backup withholding.

You will not be subject to backup withholding on payments you receive if you give the requester your correct TIN, make the proper certifications, and report all your taxable interest and dividends on your tax return.

Payments you receive will be subject to backup withholding if:

1. You do not furnish your TIN to the requester,
2. You do not certify your TIN when required (see the Part II instructions on page 3 for details),
3. The IRS tells the requester that you furnished an incorrect TIN,

4. The IRS tells you that you are subject to backup withholding because you did not report all your interest and dividends on your tax return (for reportable interest and dividends only), or

5. You do not certify to the requester that you are not subject to backup withholding under 4 above (for reportable interest and dividend accounts opened after 1983 only).

Certain payees and payments are exempt from backup withholding. See the instructions below and the separate Instructions for the Requester of Form W-9.

Also see *Special rules for partnerships* on page 1.

Penalties

Failure to furnish TIN. If you fail to furnish your correct TIN to a requester, you are subject to a penalty of \$50 for each such failure unless your failure is due to reasonable cause and not to willful neglect.

Civil penalty for false information with respect to withholding. If you make a false statement with no reasonable basis that results in no backup withholding, you are subject to a \$500 penalty.

Criminal penalty for falsifying information. Willfully falsifying certifications or affirmations may subject you to criminal penalties including fines and/or imprisonment.

Misuse of TINs. If the requester discloses or uses TINs in violation of federal law, the requester may be subject to civil and criminal penalties.

Specific Instructions

Name

If you are an individual, you must generally enter the name shown on your income tax return. However, if you have changed your last name, for instance, due to marriage without informing the Social Security Administration of the name change, enter your first name, the last name shown on your social security card, and your new last name.

If the account is in joint names, list first, and then circle, the name of the person or entity whose number you entered in Part I of the form.

Sole proprietor. Enter your individual name as shown on your income tax return on the "Name" line. You may enter your business, trade, or "doing business as (DBA)" name on the "Business name" line.

Limited liability company (LLC). Check the "Limited liability company" box only and enter the appropriate code for the tax classification ("D" for disregarded entity, "C" for corporation, "P" for partnership) in the space provided.

For a single-member LLC (including a foreign LLC with a domestic owner) that is disregarded as an entity separate from its owner under Regulations section 301.7701-3, enter the owner's name on the "Name" line. Enter the LLC's name on the "Business name" line.

For an LLC classified as a partnership or a corporation, enter the LLC's name on the "Name" line and any business, trade, or DBA name on the "Business name" line.

Other entities. Enter your business name as shown on required federal tax documents on the "Name" line. This name should match the name shown on the charter or other legal document creating the entity. You may enter any business, trade, or DBA name on the "Business name" line.

Note. You are requested to check the appropriate box for your status (individual/sole proprietor, corporation, etc.).

Exempt Payee

If you are exempt from backup withholding, enter your name as described above and check the appropriate box for your status, then check the "Exempt payee" box in the line following the business name, sign and date the form.

Generally, individuals (including sole proprietors) are not exempt from backup withholding. Corporations are exempt from backup withholding for certain payments, such as interest and dividends.

Note. If you are exempt from backup withholding, you should still complete this form to avoid possible erroneous backup withholding.

The following payees are exempt from backup withholding:

1. An organization exempt from tax under section 501(a), any IRA, or a custodial account under section 403(b)(7) if the account satisfies the requirements of section 401(f)(2),
2. The United States or any of its agencies or instrumentalities,
3. A state, the District of Columbia, a possession of the United States, or any of their political subdivisions or instrumentalities,
4. A foreign government or any of its political subdivisions, agencies, or instrumentalities, or
5. An international organization or any of its agencies or instrumentalities.

Other payees that may be exempt from backup withholding include:

6. A corporation,
7. A foreign central bank of issue,
8. A dealer in securities or commodities required to register in the United States, the District of Columbia, or a possession of the United States,
9. A futures commission merchant registered with the Commodity Futures Trading Commission,
10. A real estate investment trust,
11. An entity registered at all times during the tax year under the Investment Company Act of 1940,
12. A common trust fund operated by a bank under section 584(a),
13. A financial institution,
14. A middleman known in the investment community as a nominee or custodian, or
15. A trust exempt from tax under section 664 or described in section 4947.

The chart below shows types of payments that may be exempt from backup withholding. The chart applies to the exempt payees listed above, 1 through 15.

IF the payment is for . . .	THEN the payment is exempt for . . .
Interest and dividend payments	All exempt payees except for 9
Broker transactions	Exempt payees 1 through 13. Also, a person registered under the Investment Advisers Act of 1940 who regularly acts as a broker
Barter exchange transactions and patronage dividends	Exempt payees 1 through 5
Payments over \$600 required to be reported and direct sales over \$5,000 ¹	Generally, exempt payees 1 through 7 ²

¹See Form 1099-MISC, Miscellaneous Income, and its instructions.

²However, the following payments made to a corporation (including gross proceeds paid to an attorney under section 6045(f), even if the attorney is a corporation) and reportable on Form 1099-MISC are not exempt from backup withholding: medical and health care payments, attorneys' fees, and payments for services paid by a federal executive agency.

Part I. Taxpayer Identification Number (TIN)

Enter your TIN in the appropriate box. If you are a resident alien and you do not have and are not eligible to get an SSN, your TIN is your IRS individual taxpayer identification number (ITIN). Enter it in the social security number box. If you do not have an ITIN, see *How to get a TIN* below.

If you are a sole proprietor and you have an EIN, you may enter either your SSN or EIN. However, the IRS prefers that you use your SSN.

If you are a single-member LLC that is disregarded as an entity separate from its owner (see *Limited liability company (LLC)* on page 2), enter the owner's SSN (or EIN, if the owner has one). Do not enter the disregarded entity's EIN. If the LLC is classified as a corporation or partnership, enter the entity's EIN.

Note. See the chart on page 4 for further clarification of name and TIN combinations.

How to get a TIN. If you do not have a TIN, apply for one immediately. To apply for an SSN, get Form SS-5, Application for a Social Security Card, from your local Social Security Administration office or get this form online at www.ssa.gov. You may also get this form by calling 1-800-772-1213. Use Form W-7, Application for IRS Individual Taxpayer Identification Number, to apply for an ITIN, or Form SS-4, Application for Employer Identification Number, to apply for an EIN. You can apply for an EIN online by accessing the IRS website at www.irs.gov/businesses and clicking on Employer Identification Number (EIN) under Starting a Business. You can get Forms W-7 and SS-4 from the IRS by visiting www.irs.gov or by calling 1-800-TAX-FORM (1-800-829-3676).

If you are asked to complete Form W-9 but do not have a TIN, write "Applied For" in the space for the TIN, sign and date the form, and give it to the requester. For interest and dividend payments, and certain payments made with respect to readily tradable instruments, generally you will have 60 days to get a TIN and give it to the requester before you are subject to backup withholding on payments. The 60-day rule does not apply to other types of payments. You will be subject to backup withholding on all such payments until you provide your TIN to the requester.

Note. Entering "Applied For" means that you have already applied for a TIN or that you intend to apply for one soon.

Caution: A disregarded domestic entity that has a foreign owner must use the appropriate Form W-8.

Part II. Certification

To establish to the withholding agent that you are a U.S. person, or resident alien, sign Form W-9. You may be requested to sign by the withholding agent even if items 1, 4, and 5 below indicate otherwise.

For a joint account, only the person whose TIN is shown in Part I should sign (when required). Exempt payees, see *Exempt Payee* on page 2.

Signature requirements. Complete the certification as indicated in 1 through 5 below.

1. Interest, dividend, and barter exchange accounts opened before 1984 and broker accounts considered active during 1983. You must give your correct TIN, but you do not have to sign the certification.

2. Interest, dividend, broker, and barter exchange accounts opened after 1983 and broker accounts considered inactive during 1983. You must sign the certification or backup withholding will apply. If you are subject to backup withholding and you are merely providing your correct TIN to the requester, you must cross out item 2 in the certification before signing the form.

3. Real estate transactions. You must sign the certification. You may cross out item 2 of the certification.

4. Other payments. You must give your correct TIN, but you do not have to sign the certification unless you have been notified that you have previously given an incorrect TIN. "Other payments" include payments made in the course of the requester's trade or business for rents, royalties, goods (other than bills for merchandise), medical and health care services (including payments to corporations), payments to a nonemployee for services, payments to certain fishing boat crew members and fishermen, and gross proceeds paid to attorneys (including payments to corporations).

5. Mortgage interest paid by you, acquisition or abandonment of secured property, cancellation of debt, qualified tuition program payments (under section 529), IRA, Coverdell ESA, Archer MSA or HSA contributions or distributions, and pension distributions. You must give your correct TIN, but you do not have to sign the certification.

Secure Your Tax Records from Identity Theft

Identity theft occurs when someone uses your personal information such as your name, social security number (SSN), or other identifying information, without your permission, to commit fraud or other crimes. An identity thief may use your SSN to get a job or may file a tax return using your SSN to receive a refund.

To reduce your risk:

- Protect your SSN,
- Ensure your employer is protecting your SSN, and
- Be careful when choosing a tax preparer.

Call the IRS at 1-800-829-1040 if you think your identity has been used inappropriately for tax purposes.

Victims of identity theft who are experiencing economic harm or a system problem, or are seeking help in resolving tax problems that have not been resolved through normal channels, may be eligible for Taxpayer Advocate Service (TAS) assistance. You can reach TAS by calling the TAS toll-free case intake line at 1-877-777-4778 or TTY/TDD 1-800-829-4059.

Protect yourself from suspicious emails or phishing schemes. Phishing is the creation and use of email and websites designed to mimic legitimate business emails and websites. The most common act is sending an email to a user falsely claiming to be an established legitimate enterprise in an attempt to scam the user into surrendering private information that will be used for identity theft.

The IRS does not initiate contacts with taxpayers via emails. Also, the IRS does not request personal detailed information through email or ask taxpayers for the PIN numbers, passwords, or similar secret access information for their credit card, bank, or other financial accounts.

If you receive an unsolicited email claiming to be from the IRS, forward this message to phishing@irs.gov. You may also report misuse of the IRS name, logo, or other IRS personal property to the Treasury Inspector General for Tax Administration at 1-800-366-4484. You can forward suspicious emails to the Federal Trade Commission at: spam@uce.gov or contact them at www.consumer.gov/idtheft or 1-877-IDTHEFT(438-4338).

Visit the IRS website at www.irs.gov to learn more about identity theft and how to reduce your risk.

What Name and Number To Give the Requester

For this type of account:	Give name and SSN of:
1. Individual	The individual
2. Two or more individuals (joint account)	The actual owner of the account or, if combined funds, the first individual on the account ¹
3. Custodian account of a minor (Uniform Gift to Minors Act)	The minor ²
4. a. The usual revocable savings trust (grantor is also trustee)	The grantor-trustee ¹
b. So-called trust account that is not a legal or valid trust under state law	The actual owner ¹
5. Sole proprietorship or disregarded entity owned by an individual	The owner ¹
For this type of account:	Give name and EIN of:
6. Disregarded entity not owned by an individual	The owner
7. A valid trust, estate, or pension trust	Legal entity ⁴
8. Corporate or LLC electing corporate status on Form 8832	The corporation
9. Association, club, religious, charitable, educational, or other tax-exempt organization	The organization
10. Partnership or multi-member LLC	The partnership
11. A broker or registered nominee	The broker or nominee
12. Account with the Department of Agriculture in the name of a public entity (such as a state or local government, school district, or prison) that receives agricultural program payments	The public entity

¹ List first and circle the name of the person whose number you furnish. If only one person on a joint account has an SSN, that person's number must be furnished.

² Circle the minor's name and furnish the minor's SSN.

³ You must show your individual name and you may also enter your business or "DBA" name on the second name line. You may use either your SSN or EIN (if you have one), but the IRS encourages you to use your SSN.

⁴ List first and circle the name of the trust, estate, or pension trust. (Do not furnish the TIN of the personal representative or trustee unless the legal entity itself is not designated in the account title.) Also see *Special rules for partnerships* on page 1.

Note. If no name is circled when more than one name is listed, the number will be considered to be that of the first name listed.

Privacy Act Notice

Section 6109 of the Internal Revenue Code requires you to provide your correct TIN to persons who must file information returns with the IRS to report interest, dividends, and certain other income paid to you, mortgage interest you paid, the acquisition or abandonment of secured property, cancellation of debt, or contributions you made to an IRA, or Archer MSA or HSA. The IRS uses the numbers for identification purposes and to help verify the accuracy of your tax return. The IRS may also provide this information to the Department of Justice for civil and criminal litigation, and to cities, states, the District of Columbia, and U.S. possessions to carry out their tax laws. We may also disclose this information to other countries under a tax treaty, to federal and state agencies to enforce federal nontax criminal laws, or to federal law enforcement and intelligence agencies to combat terrorism.

You must provide your TIN whether or not you are required to file a tax return. Payers must generally withhold 28% of taxable interest, dividend, and certain other payments to a payee who does not give a TIN to a payer. Certain penalties may also apply.

CONFLICT OF INTEREST QUESTIONNAIRE

FORM CIQ

For vendor doing business with local governmental entity

This questionnaire reflects changes made to the law by H.B. 23, 84th Leg., Regular Session.

This questionnaire is being filed in accordance with Chapter 176, Local Government Code, by a vendor who has a business relationship as defined by Section 176.001(1-a) with a local governmental entity and the vendor meets requirements under Section 176.006(a).

By law this questionnaire must be filed with the records administrator of the local governmental entity not later than the 7th business day after the date the vendor becomes aware of facts that require the statement to be filed. See Section 176.006(a-1), Local Government Code.

A vendor commits an offense if the vendor knowingly violates Section 176.006, Local Government Code. An offense under this section is a misdemeanor.

OFFICE USE ONLY

Date Received

1 Name of vendor who has a business relationship with local governmental entity.

2 Check this box if you are filing an update to a previously filed questionnaire.

(The law requires that you file an updated completed questionnaire with the appropriate filing authority not later than the 7th business day after the date on which you became aware that the originally filed questionnaire was incomplete or inaccurate.)

3 Name of local government officer about whom the information in this section is being disclosed.

Name of Officer

This section (item 3 including subparts A, B, C, & D) must be completed for each officer with whom the vendor has an employment or other business relationship as defined by Section 176.001(1-a), Local Government Code. Attach additional pages to this Form CIQ as necessary.

A. Is the local government officer named in this section receiving or likely to receive taxable income, other than investment income, from the vendor?

Yes No

B. Is the vendor receiving or likely to receive taxable income, other than investment income, from or at the direction of the local government officer named in this section AND the taxable income is not received from the local governmental entity?

Yes No

C. Is the filer of this questionnaire employed by a corporation or other business entity with respect to which the local government officer serves as an officer or director, or holds an ownership interest of one percent or more?

Yes No

D. Describe each employment or business and family relationship with the local government officer named in this section.

4

Signature of vendor doing business with the governmental entity

Date

Bayside Community Center

Agreement between Galveston County and Contractor

Agreement for: Bayside Community Center

This contract is entered into between Galveston County and the Contractor named below pursuant to Sub chapter B, Chapter 271, Texas Local Government Code, and the referenced Request for Design Build Services

Contract No: (to be determined)

Bid No: B161012

Contractor: (to be determined)

Galveston County Authorized Representative: J. Dudley Anderson, County Architect

Article I.

The Work

Section 1.01 The Contractor and Galveston County agree that the materials and equipment to be furnished and the work to be done by the Contractor are as follows:

- General construction to renovate the building and site at 823 Grand Avenue Bacliff, Texas

Section 1.02 The Contractor shall be held accountable for the following Project related responsibilities: furnish all labor and supervision; furnish, supply and install all equipment, material, supplies, tools, scaffolding, hoisting, transportation, unloading and handling; do all things required to complete the work described above on the Project all in accordance with the drawings and Project Manual prepared by the Architect or Engineer; and furnish all necessary information, shop drawings, details, samples, brochures, etc. For Owner/Architect or Engineer approval, as may be required.

Article II.

Time of Commencement and Completion

Section 2.01 The Contractor shall start the work upon notice to proceed and shall execute the work with diligence and dispatch so as to maintain such schedules and milestones as established by Galveston County's authorized Representative. The Contractor agrees to complete portions and the whole of the work by the following anticipated dates: December 31, 2015

Section 2.02 The Contractor is cautioned that schedules and milestones are subject to review and revision, and in such event, such revisions will be made available for the Contractor's information at the office of Galveston County's authorized Representative. In the event the

Galveston County Project 12-006

Contractor should fail to maintain Galveston County's authorized Representative's progress schedule or the schedule as established above, Galveston County reserves the right, after 48 hours formal notice, either by letter or telegram to the Contractor, to procure the materials, equipment, and labor necessary to proceed with, or to complete the work, or any portion thereof from other sources and charge the cost thereof to the Contractor.

Section 2.03 Time is of the essence in this Agreement.

Article III.

The Contract Sum

Section 3.01 Galveston County agrees to pay the Contractor for the satisfactory performance of his work the total sum of:

Amount in words Dollars and 00/100

(\$?.00), payments to be made as described herein in current funds subject to additions and deductions for changes, as may be agreed upon in writing, and to make payments on account thereof as follows:

Section 3.02 On the established day of each month, the Contractor shall deliver to Galveston County through Galveston County's authorized Representative a detailed, quadruplicate statement acceptable to Galveston County's authorized Representative, and if required, supported by receipts, vouchers, etc. showing values of all materials delivered and work completed up to the established billing date for which payment is requested. Monthly and final payments will be made to the Contractor from Galveston County. It is specifically understood and agreed that prior to submission of the first statement, the Contractor will deliver to Galveston County's authorized Representative, for review and approval, a detailed breakdown of this contract sum showing a schedule of values for the various parts of the work. Once accepted by Galveston County's authorized Representative, this schedule of values will be used as a basis for checking the Contractor's monthly statement.

Section 3.03 The Contractor shall, with the second and each succeeding monthly request for payment, submit receipts and/or an affidavit and waiver of bond claim showing all payments made for labor and materials and on account for all work covered in the previous months request for payment. Affidavit and waiver of bond claims may be required to be submitted from Contractors, suppliers, and/or Sub-Contractors (all tier). The Contractor shall be required to execute a general release satisfactory to Owner, prior to receiving final payment.

Section 3.04 Five percent (5%) of each payment shall be retained, unless specific provisions to the contrary are indicated in the contract documents.

Section 3.05 No payment made under this Agreement, including the final payment, shall be conclusive evidence of the performance of the work, either wholly or in part, and no payment shall be construed as an acceptance of defective work or improper materials.

Section 3.06 The Contractor shall save and keep Galveston County's authorized

Galveston County Project 12-006

Representative, Galveston County and Galveston County's property free from all claims, including bond claims, legal or equitable, arising out of the Contractor's work hereunder. In the event any such claim is filed by anyone claiming by, through, or under the Contractor, the Contractor shall remove and discharge same, by bonding or otherwise, within five (5) days of the filing thereof.

Article IV.

The Contract Documents

Section 4.01 The contract documents consist of this Agreement and any exhibits attached hereto; Proposal Documents, Proposal Form, General Conditions of the Contract, the Project Manual, the Drawings, and all addenda issued prior to and all modifications issued after execution of the Agreement between Galveston County and Galveston County's authorized Representative and agreed upon by the parties.

Section 4.02 The Contractor agrees to perform the work subject to the final approval of the authorized representative of Galveston County, in accordance with the contract documents.

Section 4.03 Contract documents are available, at reasonable times, at the office of Galveston County's authorized Representative for examination by the Contractor.

Section 4.04 No extra work shall be performed under this Agreement, except upon receipt of a written order from Galveston County's authorized Representative or Galveston County.

The Project Manual and Drawings are enumerated as follows:

Project Manual	2-29-16
Addenda	
Drawings:	
Full List of Drawings (See Sheet A.001).....	2-29-16

Article V.

Insurance and Indemnity

Section 5.01 The Contractor agrees to, at the time of execution of this Agreement, furnish Galveston County's authorized Representative with certificates of insurance from an insurance company (or other source) acceptable to Galveston County. These certificates should certify that the Contractor is protected on the work with worker's compensation and employer's liability, public liability and bodily injury, property damage insurance, and any other insurance as required by the contract documents and in accordance with the attachment to this Agreement. The Contractor will not be permitted to start work at the site until these certificates are filed with Galveston County. Compliance by the Contractor with the foregoing requirements, as to carrying insurance and furnishing certificates, shall not relieve the Contractor of its liabilities and obligations.

Section 5.02 For ten (\$10.00) dollars and other good and valuable consideration, the receipt whereof is hereby acknowledged, and to the fullest extent permitted by law, the Contractor agrees to indemnify and hold harmless Galveston County, Galveston County's authorized Representative, the Architect or Engineer, and all of their agents and employees from and against

Galveston County Project 12-006

claims, damages, losses and expenses, including but not limited to attorneys' fees arising out of or resulting from the performance or failure in performance of the Contractor's work under this Agreement provided that any such claim, damage, loss, or expense (1) is attributable to bodily injury, sickness, disease, or death, or to injury to or destruction of tangible property including the loss of use resulting therefrom, (2) is caused, in whole or in part, by any negligent act or omission of the Contractor or anyone directly or indirectly employed by the Contractor, or anyone for whose acts the Contractor may be liable, regardless of whether caused in part by a party indemnified hereunder. Such obligations shall not be construed to negate, abridge, or otherwise reduce any other right or obligation of indemnity which would otherwise exist as to any party or person described in this paragraph. In any and all claims against Galveston County's authorized Representative, or any of its agents or employees, by any employee of the Contractor, or anyone directly or indirectly employed by the Contractor, or anyone for whose acts he may be liable, the indemnification obligation under this paragraph 5.02 shall not be limited in any way by any limitation on the amount or type of damages, compensation, or benefits payable by or for the Contractor under worker's compensation acts, disability benefit acts, or other employee benefit acts.

Section 5.03 The obligations of the Contractor, under paragraph 5.02, shall not extend to the liability of the Architect or Engineer, his agents, or employees, arising out of the preparation or approval of maps, drawings, opinions, reports surveys, change orders, designs, or Project Manual and/or the giving of or failure to give directions or instructions by the Architect or Engineer, his agents or employees, providing such giving or failure to give is the primary cause of the injury or damage

Section 5.04 The Contractor agrees to obtain, maintain, and pay for such contractual liability insurance coverage and endorsements as will insure the indemnification obligation of the Contractor pursuant to paragraph 5.02 above.

Article VI.

Performance Bond and Labor and Material Payment Bond

Section 6.01 The Contractor agrees to furnish and pay for a 100% Performance Bond and a 100% Labor and Material Payment Bond on the bond forms issued with this Agreement naming the Galveston County as Obligee. Bonds must be issued by a company acceptable to Galveston County and must be accompanied by a Power of Attorney. The bonds are to be delivered with this executed Agreement.

Article VII.

Warranty

Section 7.01 The Contractor agrees to promptly make good, without cost to Galveston County, any and all defects, due to faulty workmanship and/or materials, which may appear within the guarantee or warranty period so established in the contract documents. If no such period is stipulated in the contract documents, then such guarantee shall be for a period of one (1) year from date of substantial completion and acceptance of the work by Galveston County. The Contractor further agrees to provide any and all guarantees as required by the terms of the contract documents, as a condition precedent to final payment

Galveston County Project 12-006

Article VIII.

Changes in the Work

Section 8.01 The Contractor may be ordered in writing by Galveston County, without invalidating this Agreement, to make changes in the work within the general scope of this Agreement. These changes may consist of additions, deletions, or other revisions, the contract sum and the contract time being adjusted accordingly. The Contractor, prior to the commencement of such changed or revised work, shall submit promptly to Galveston County's authorized Representative written copies of any claim for adjustment to the contract sum and contract time for such revised work in a manner consistent with the contract documents

Section 8.02 Where changes in the work involve both additions and deletions, percentages for overhead and profit shall be applied to the net increase of such values for labor and materials.

Section 8.03 The amount to be paid by Galveston County for changes in the work, as outlined in paragraph 8.01 above, shall be made on the basis of one of the following methods:

- a) by mutual acceptance of a lump sum properly itemized and supported by sufficient substantiating data to permit evaluation and agreed upon by Galveston County's authorized Representative and the Contractor, or
- b) by unit prices stated in the contract documents, or
- c) if no such unit prices are set forth and if the parties cannot agree upon a lump sum, then the actual net cost in money to the Contractor of materials and labor (including insurance and applicable taxes) required, plus rental of plant equipment (other than small tools and small equipment) plus compensation for overhead and for profit as noted in Article 12. (Field overhead will not be considered as part of actual net cost), or
- d) by the method provided in subparagraph 8.04.

Section 8.04 If none of the above methods set forth in clauses 8.03 (a), 8.03 (b), 8.03 (c) is agreed upon, the Contractor, provided he receives a written order signed by Galveston County shall promptly proceed with the work involved. The cost of such work shall be determined by Galveston County's authorized Representative on the basis of reasonable expenditures and savings of those performing the work attributable to the change, including, in the case of an increase in the contract sum, a reasonable allowance for overhead and profit. In such case, and also under clauses 8.03 (c) and 8.03 (d) above, the Contractor shall keep and present, in such form as Galveston County's authorized Representative may prescribe, an itemized accounting together with appropriate supporting data for inclusion in a change order. Unless otherwise provided in the contract documents, cost shall be limited to the following: cost of materials including cost of delivery, cost of labor including social security, old age and unemployment insurance and fringe benefits required by Agreement or custom; workers or workmen's compensation insurance; bond premiums; rental value of equipment and machinery; and the additional costs of supervision and field office personnel directly attributable to the change. Pending final determination of cost, payments, on account shall be made as determined by Galveston County. The amount of credit to be allowed by the Contractor for any deletion or change which results in a net decrease in the contract sum will be the amount of the actual net cost as confirmed by Galveston County. When both additions and credits covering related work or substitutions are involved in any one change, the allowance for overhead and profit shall be figured on the basis of the net increase, if any with respect to that change.

Galveston County Project 12-006

Section 8.05 Owner's Audit

- a) Owner's duly authorized representative shall have access, at all reasonable times, to all Contractor's personnel, books, records, correspondence, instructions, plans, drawings, receipts, vouchers and memoranda of every description pertaining to any change(s) for the purpose of auditing and verifying Contractor's net cost of change or for any other reasonable purpose. Owner's representative shall have the right to reproduce any of the aforesaid documents. Contractor shall preserve, and shall cause its Contractors to preserve all the aforesaid documents for a period of two years after the completion and acceptance or termination of work.

Section 8.06 For work performed by a Sub-Contractor, the Contractor will be allowed to add 5% only and said Sub-Contractor mark-up shall not exceed the agreed upon percentages noted in Article 12 for overhead and profit

Article IX.

Contractor Responsibilities

Section 9.01 The Contractor shall provide sufficient, safe, and proper facilities at all times for the inspection of the work by Galveston County and Galveston County's authorized Representative, or their authorized representatives. The Contractor shall, within a 24-hour notice from Galveston County's authorized Representative, proceed to take down all portions of the work and remove from the grounds or buildings, all materials, whether worked or un-worked, which Galveston County's authorized Representative, Galveston County, or their authorized representatives shall condemn as unsound or improper, or as in any way failing to conform to the contract documents. The Contractor shall make good at its own expense, all work damaged or destroyed thereby

Section 9.02 The Contractor agrees, in the performance of this Agreement, to comply with all federal, state, municipal, and local laws, ordinances, codes and governing regulations, to pay all costs and expenses required thereby; to pay all fees, charges, assessments, and taxes, and to pay all fringe and other benefits required by Agreement or law.

Section 9.03 The Contractor shall pay all royalties and license fees. He shall defend all suits or claims for infringement of any patent rights and shall save Galveston County, Galveston County's authorized Representative, and Architect or Engineer harmless from loss on account thereof, except that Galveston County shall be responsible for all such loss when a particular design, process or the product of a particular manufacturer or manufacturers is specified, but if the Contractor has reason to believe that the design, process or product specified is an infringement of a patent, he shall be responsible for such loss unless he promptly gives such information to Galveston County.

Section 9.04 Should the Contractor become insolvent, or at any time, refuse or neglect to supply a sufficiency of properly skilled workers, or equipment and materials of the proper quality, or fail in any respect to prosecute the work with promptness and diligence, or fail in the performance of any of the Agreements herein contained, Galveston County shall be at liberty, after 48 hours written notice to the Contractor, to provide any such labor, equipment,, and materials and deduct the cost thereof, from any money then due or thereafter to become due to the Contractor, under this Agreement. In the event of such refusal, neglect, or failure Galveston

Galveston County Project 12-006

County shall also be at liberty to terminate the employment of the Contractor. Consequently, Galveston County may enter upon the premises to take possession, for the purpose of completing the work included under this Agreement, of all materials, tools, and appliances thereon, and to employ any other person or persons to finish the work and provide the materials therefore. In case of such discontinuance of the employment, the Contractor shall not be entitled to receive any further payment under this Agreement until the said work shall be wholly finished. If the unpaid balance of the amount to be paid under this Agreement shall exceed the expense incurred by Galveston County in finishing the work, such excess shall be paid by Galveston County to the Contractor. If such expense shall exceed such unpaid balance, the Contractor shall pay the difference to Galveston County. The expense incurred by Galveston County, as herein provided, either for furnishing materials, or finishing the work, and any damage incurred through such default, shall be chargeable to the Contractor

Section 9.05 Notwithstanding the above paragraph, Galveston County reserves the right to terminate this Agreement for its convenience upon written notice to the Contractor. In such instance the Contractor will be paid its share of the contract amount proportionate to the percentage of its work completed and other reasonable cancellation costs incurred as a result of said termination. No payments shall be made for anticipated overhead and profit. Prior to making any payments under this clause, the Owner shall have the right to audit the records of the Contractor

Section 9.06 The Contractor agrees to adhere to the federal Occupational Safety & Health Act, state and local safety regulations and Galveston County's authorized Representative's safety and health program so as to avoid injury or damage to persons or property, and to be directly responsible for damage to persons and property resulting from failure to do so.

Section 9.07 In the event the Contractor after a 24-hour written notice from Galveston County, Galveston County's authorized Representative, or duly authorized representative, fails to take corrective action to insure compliance with said safety regulations or removal of rubbish and debris resulting from his work, Galveston County shall undertake these obligations and charge the cost of same to the Contractor's account without further notice to the Contractor.

Section 9.08 The Contractor agrees to notify Galveston County's authorized Representative's representative on the jobsite of all accidents which may occur to persons or property and shall provide Galveston County's authorized Representative's representative with a copy of all accident reports on appropriate forms. All reports shall be signed by the Contractor or his authorized representative and submitted within five (5) days of occurrence

Section 9.09 The Contractor shall procure its materials from such sources, and employ such labor subject to contract terms and conditions in order to ensure harmonious labor relations on the site and prevent strikes or labor disputes by its employees or other trade employees. The Contractor, in the event of a labor dispute including strikes, shall take whatever action is required in order to prevent the disruption of work on the Project site.

Section 9.10 The Contractor will not assign this Agreement, nor any moneys due or to become due under this Agreement, nor sublet the whole or any part of the work to be performed hereunder, without the written consent of the Owner and Galveston County's authorized Representative. In the event of such a consent, a Sub-Contractor must comply with all the

Galveston County Project 12-006

requirements of this Agreement.

Section 9.11 The Contractor agrees that all disputes concerning the jurisdiction of trades shall be adjusted in accordance with any plan for the settlement of jurisdictional disputes which may be in effect either nationally or in the locality in which the work is being done. The Contractor shall be bound by, and shall abide by, all such adjustments and settlements of jurisdictional disputes, whether or not the Contractor is signature bound by the Agreement establishing the impartial jurisdictional disputes board and/or its successors. The Contractor agrees not to cause a work stoppage, due to the jurisdictional assignment of work

Section 9.12 The Contractor shall submit to Galveston County's authorized Representative upon request, copies of orders placed for the various materials required for the Project or authentic stock lists if such material is normally a stock item. Order copies need not reflect prices but should indicate type of material, quantity, vendor name, and address, etc. The Contractor shall be required to submit to Galveston County's authorized Representative a monthly material status report, or more often if required by Galveston County's authorized Representative, as a prerequisite for the monthly progress payment. The Contractor shall notify Galveston County's authorized Representative immediately upon learning of a change of status of any material, equipment, or supplies

Section 9.13 The Contractor shall continuously and adequately protect all his work and will immediately replace all damaged and defective work

Section 9.14 The Contractor agrees to maintain an adequate force of experienced workers and the necessary materials, supplies, and equipment to meet the requirements of Galveston County's authorized Representative and other trades in order to maintain construction progress schedules, as established by Galveston County's authorized Representative. In the event that his force is, in the judgment of Galveston County's authorized Representative, inadequate to meet the established schedules during the regular working hours, the Contractor agrees to work sufficient overtime hours or increase his work force to meet such schedules at no extra cost to Galveston County. If for reasons not already stated, Galveston County's authorized Representative requires and directs the Contractor to work overtime, including Saturdays, Sundays or Holidays, the Contractor will be reimbursed the net premium rate only. The net premium rate is understood to mean the actual premium labor cost, including applicable taxes and wage additives required by trade Agreement or by law, but without additives for overhead, labor efficiency, or profit.

Section 9.15 The Contractor agrees to employ competent administrative, supervisory, and field personnel to accomplish the work, including layout and engineering and preparation and checking of shop drawings. If required, the Contractor shall substantiate this employment of competent personnel to Galveston County's authorized Representative's satisfaction before initiating any work

Section 9.16 The Contractor shall insure that all construction tools, equipment, temporary facilities, and other items used in accomplishing the work, whether purchased, rented, or otherwise provided by the Contractor or provided by others, are in a safe, sound, and good condition, must be capable of performing the functions for which they are intended and must be maintained in conformance with applicable laws and regulations

Galveston County Project 12-006

Section 9.17 If the Contractor is delayed at any time in the progress of the work by any act or neglect of the Owner, Galveston County's authorized Representative, or the Architect or Engineer, or by any employee of either, or by any separate contractor employed by the Owner, or by changes ordered in the work, or by labor disputes, fire, unusual delay in transportation, adverse weather conditions not reasonably anticipatable, unavoidable casualties or any causes beyond the Contractor's control, or by delay authorized by the Owner or Galveston County's authorized Representative, or by any other cause which Galveston County's authorized Representative determines may justify the delay, then the contract time shall be extended by amendment for such reasonable time as Galveston County's authorized Representative and Owner may determine.

Section 9.18 Right-To-Know each Contractor is required to implement the provisions of the right-to-know law, if any, as enacted by the state in which the work is being performed. Before using on site any material listed in the right-to-know substance list, each Contractor will furnish Galveston County's authorized Representative a copy of the material safety data sheet for that substance

Section 9.19 In the event the Contractor employs independent contractors, as well as payroll labor, to discharge its obligations hereunder, the Contractor acknowledges and understands that it does so at its own risk and that federal, state and/or local agencies may dispute the independent contractor status and assess penalties, fines, and costs should there be a determination to reclassify such workers. In that event, the Contractor agrees that it will defend, indemnify and hold Galveston County harmless from any fines, costs, damages, penalties, attorneys fees, and causes of action, including without limitation, personal injury or property damage, arising out of or relating in any way to such a determination.

Article X.

Galveston County's authorized Representative Responsibilities

Section 10.01 Galveston County's authorized Representative will be the Owner's representative and will administer the contract as described in the contract documents. Galveston County's authorized Representative will advise and consult with the Owner. Galveston County's authorized Representative will have authority to act on behalf of the Owner to the extent provided in the contract documents, as they may be modified by change order in accordance with other provisions of the trade contract

Section 10.02 The Contractor agrees to perform the work under the general direction and coordination of Galveston County's authorized Representative in accordance with the contract documents. Any directive given by Galveston County's authorized Representative shall be binding on the Contractor.

Section 10.03 Galveston County's authorized Representative, acting for the Owner and subject to the Owner's delegation of such authority, may perform all tasks necessary or appropriate to administer and manage the trade contract, and undertake any action with respect to the Contractor, that the Owner is entitled to undertake.

Section 10.04 Galveston County's authorized Representative shall not give instructions or

Galveston County Project 12-006

orders directly to employees or workers of the Contractor, except to persons designated as authorized representatives of the Contractor.

Article XI.

Equal Opportunity

Section 11.01 During the performance of this Agreement, the Contractor agrees not to discriminate against any employee or applicant for employment because of race, color, religion, sex, or national origin. The Contractor will take affirmative action to insure that applicants are employed without regard to their race, color, religion, sex, or national origin. The Contractor will comply with all provisions of Executive Order No. 11246, Section 503 of the Rehabilitation Act of 1973, as Amended, the Vietnam Era Veterans' Readjustment Assistance Act of 1974, as Amended, (38 U.S.C. 4212) and their implementing regulations at 41 CFR Chapter 60.

Article XII.

Alterations

Section 12.01 Refer to the Proposal Form for the overhead and profit allowable under Article 8.03. A, 8.03 B, 8.03 C: 10% Overhead, 15% Profit

Article XIII.

Complete Agreement

Section 13.01 This Agreement, together with all documents, Project Manual, drawings, incorporated herein by reference, constitute the entire Agreement between Galveston County and Contractor. There are no terms, conditions, or provisions, either oral or written, between the parties hereto, other than those contained herein. This Agreement supersedes any and all written representations, inducements, or understandings of any kind or nature between the parties hereto, relating to the particular Project involved herein

Section 13.02 The said parties for themselves, their heirs, successors, executors, administrators and assigns, do hereby agree to the full performance of the covenants herein contained.

Galveston County Project 12-006

This Contract is issued pursuant to award made by Commissioners' Court on September 1, 2015.

EXECUTED this ____ day of (month) and (year).

COUNTY OF GALVESTON, TEXAS

BY:

Mark Henry, County Judge

ATTEST:

Dwight Sullivan, County Clerk

CONTRACTOR

BY:

Signature - Title

Printed Name

Bayside Community Center

Bid Number
Bid Date
Bid Time

B161012
March 29, 2016
10:00 A.M.

GENERAL CONDITIONS OF THE AGREEMENT

Article

- 1.....CONTRACT DOCUMENTS
 - a.....The Work
 - b.The Project
 - c.....The Bid Package
 - d.Abbreviations
 - e.....General Definitions
- 2.....EXECUTION, CORRELATION, AND INTENT
- 3.....OWNERSHIP AND USE OF DOCUMENTS
- 4.....OWNER
 - a.....Definition
 - b.Information and Services Furnished by the Owner
- 5.....ARCHITECT OR ENGINEER
 - a.....Definition
 - b.Architect or Engineer Duties During Construction
- 6.....CONSTRUCTION MANAGER
 - a.....Definition
 - b.Administration of the Contract
- 7.....CONTRACTOR
 - a.....Definition
 - b.Review of Contract Documents
 - c.....Supervision and Construction Procedures
 - d.Labor and Materials
- 8.....WARRANTY
- 9.....TAXES
- 10.....SUPERINTENDENT
- 11.....DRAWINGS AND PROJECT MANUAL AT THE SITE
- 12.....USE OF SITE
- 13.....COMMUNICATIONS
- 14.....SUB-CONTRACTORS
 - a.....Definition
 - b.Award of Sub-Contractors and other portions of the Work
 - c.....Sub-Trade contractual relations
- 15.....SEPARATE CONTRACTS
 - a.....Mutual responsibility of Contractors
- 16.....GOVERNING LAW AND VENUE
- 17.....INDEMNIFICATION
- 18.....CLAIM FOR DAMAGES
- 19.....RIGHTS AND REMEDIES
- 20.....TESTS
- 21.....INTEREST
- 22.....TIME
 - a.....Definitions
 - b.Progress and Completion
 - c.....Delays and Extension of Time
- 23.....PAYMENTS AND COMPLETION
 - a.....Progress Payments
 - b.Payments withheld
 - c.....Failure of Payment
 - d.Substantial Completion
 - e.....Final Completion and Final Payment
- 24.....PROTECTION OF PERSONS PROPERTY
- 25.....EMERGENCIES
- 26.....INSURANCE
 - A.....Contractor Liability Insurance
 - B.....Property Insurance

Bayside Community Center

Bid Number

B161012

Bid Date

March 29, 2016

Bid Time

10:00 A.M.

- 27.....CHANGES IN THE WORK
 - a.....Change Authorization/Contract Amendments
 - b.Concealed Conditions
 - c.....Claims for Additional Cost
- 28.....UNCOVERING AND CORRECTION OF WORK
 - a.....Uncovering Work
 - b.Correction of Work
- 29.....TERMINATION OF THE CONTRACT
 - a.....Termination by the Contractor
 - b.Termination by the Owner or Construction Manager
 - c.....Termination for Convenience
- 30.....TEMPORARY SERVICES AND SYSTEMS
 - a.....Temporary Electric System
 - b.Temporary Heating
 - c.....Temporary Water
 - d.Housekeeping-Cleaning, Rubbish and Trash removal
 - e.....Vehicle Cleaning-Trucking
 - f.Site Security
 - g.Personnel and Property Protection
- 31.....ORDER OF PRECEDENCE
- 32.....WAGE RATES
- 33.....FORCE MAJEURE
- 34.....SALVAGE
- 35.....OPEN RECORDS
- 36.....PERFORMANCE AND PAYMENT BOND(S)

Bayside Community Center

Bid Number B161012
Bid Date March 29, 2016
Bid Time 10:00 A.M.

SECTION 00200 General Terms and Conditions of the Contract

1. Contract Documents

- A. The Work - For the purpose of this document, the term "Work" is the work defined in Article 1 of the Trade Contract
- B. The Project is the total construction to be performed under the Agreement between the Owner and Galveston County's authorized Representative of which the Work is a part.
- C. Bid Package
 - 1. The project is to be constructed under a general contract.
- D. Abbreviations
 - 1. The language of the Project Manual and elsewhere in the Contract Documents is of the abbreviated type in certain instances, and implies words and meanings which will be appropriately interpreted.
 - 2. Actual word abbreviations of a self-explanatory nature have been included in the Project Manual and Drawings. These are generally defined in the Project Manual Sections at the first instance of use of each term so abbreviated.
 - 3. Singular words will be interpreted as plural and plural words will be interpreted as singular wherever applicable and the full context of the requirements so indicates.
- E. General Definitions
 - 1. The word "County" in this contract refers to the County of Galveston.
 - 2. The word "Contractor" refers to the person or entity agreeing to perform the work in this contract and is also referred to as the "Contractor"
 - 3. "Program Administrator" refers to the person designated by County to act on its behalf in administering this contract.
 - 4. "Provide", or "perform": To supply, install and connect up complete and ready for safe and regular operation of particular work referred to unless specifically noted otherwise.
 - 5. "Furnish" to supply, deliver to site and transfer to others for installation.
 - 6. "Install": To receive, unload, distribute, construct, erect, mount, and connect complete with related accessories.
 - 7. "Supply": To purchase, procure, acquire and deliver complete with related accessories.
 - 8. "Product": The term "product" shall include materials, equipment and systems.
 - 9. "As approved": Where used in conjunction with the Galveston County's authorized Representative's or the Architect or Engineer's response to submittals, requests, applications, inquiries, reports and claims by the Contractor, the meaning of the term "approved" shall not exceed the limitations of the Galveston County's authorized Representative's or the Architect or Engineer's responsibilities and duties as established in the contract documents.
 - a. In no case shall "approval" by Galveston County's authorized Representative or the Architect or Engineer be interpreted as a release of the Contractor from responsibilities to fulfill the requirements of the Contract Documents.
 - b. "Approval", where required for an item, shall be obtained from the Architect or Engineer through Galveston County's authorized Representative in writing.
 - 10. The term "Indicated" is a cross reference to details, notes, or schedules on the drawings, other paragraphs or schedules in the Project Manual, and similar means of recording requirements in the Contract Documents.
 - a. Where terms such as "shown", "noted", "scheduled", and "specified" are used instead of "indicated, it is for purpose of helping the reader accomplish the cross reference, and

Bayside Community Center

Bid Number B161012
Bid Date March 29, 2016
Bid Time 10:00 A.M.

no limitation of location is intended except as specifically noted.

11. "Directed", "Requested", Etc.: Where not otherwise explained, terms such as "directed", "requested", "authorized", "selected", "approved", "required", "accepted", and "permitted" mean "directed by the Architect or Engineer, Galveston County's authorized Representative or Owner's Representative", "requested by the Architect or Engineer, Galveston County's authorized Representative or Owner's Representative", etc. However, no such implied meaning will be interpreted to extend the Architect or Engineer's or Galveston County's authorized Representative's responsibility in the Contractor's area of construction supervision.
12. "Installer": The person or entity engaged by the Contractor or his or Sub-Contractor for the performance of a particular unit of work at the project site, including installation, erection, application and similar required operations. It is a general requirement that installers be recognized experts in the work they are engaged to perform.
13. "Suitable", "reasonable", "proper", "correct" and "necessary": Such terms shall mean as suitable, reasonable, proper, correct, or necessary for the purpose intended as required by the contract documents, subject to the judgment of the Architect or Engineer or Galveston County's authorized Representative.
14. "Including", "Such as": The terms "including" and "such as" shall always be taken in most inclusive sense, namely, "including, but not limited to", and "such as, but not limited to"
15. "Option": The term "option" shall mean a choice from the specified products or procedures which shall be made by the Contractor. The choice is not "whether" the work is to be performed, but "which" product or "which" procedure is to be used. The product or procedure chosen by the Contractor shall be provided at no increase in the cost to the Owner and with no lessening of the Contractor's responsibility for its performance.
16. "Exposed": The term "exposed" shall mean any item or surface, exterior or interior, which can be seen by a person outside the building, or seen by a person inside any usable space within the building during normal activity.
 - a. Mechanical and electrical rooms, air handling rooms, storage rooms and penthouses shall be considered to have exposed surfaces, as shall the mechanical and electrical construction within them.
 - b. The interiors of closets and alcoves shall be considered exposed surfaces, and shall be finished to match the finish of the adjoining room or space, unless another finish is shown.
 - c. The interiors of cabinets shall be considered exposed, but a finish different from that of the exterior may be permitted or required.
 - d. Spaces which are not normally occupied or used by occupants or building staff, such as, shafts, hoist ways, tunnels, ceiling plenums, attics, and crew spaces shall be considered "concealed" spaces, unless finishes are shown or specified for their surfaces
17. "At no additional cost": The term "at no additional cost" shall mean at no additional cost to the Owner, the Architect or Engineer, or Galveston County's authorized Representative.
18. "Testing Laboratory": An independent entity engaged to perform specific inspections or tests of the Work, either at the project site or elsewhere; and to report and interpret the results of those inspections or tests.
19. Where the word "similar" appears on the drawings, it shall be interpreted in its general sense and not as meaning identical and all details shall be worked out in relation to their location and connection with other parts of the Work.
 - a. Where on any drawings a portion of the Work is drawn out and the remainder is indicated in outline, the parts drawn out shall also apply to parts outlined.

2. Executions, Correlation, and Intent

- A. By executing his Agreement, Contractor represents that he has visited the site, familiarized himself with the local conditions under which the Work is to be performed and correlated his observances with the requirements of the Contract Documents. Claims, as a result of failure to do so, will not be considered.
 1. The Contract shall be signed in triplicate by the Owner and Contractor.

Bayside Community Center

Bid Number B161012
Bid Date March 29, 2016
Bid Time 10:00 A.M.

- B. The intent of the Contract Documents is to include all items necessary for the proper execution and completion of the Work. The Contract Documents are complementary, and what is required by any one shall be as binding as if required by all. Work not covered in the Contract Documents will not be required unless it is consistent therewith and is reasonably inferable therefrom as being necessary to produce the intended results. Words and abbreviations in the Contract Documents which have well known technical or trade meanings are used in accordance with such recognized meanings
- C. The organization of the Project Manual into divisions, sections and articles, and the arrangements of Drawings shall not control Galveston County's authorized Representative in dividing the Work among Contractors or in establishing the extent of Work to be performed by any trade
- D. Written interpretations necessary for the proper execution or progress of the Work, in the form of drawings or otherwise, will be issued with reasonable promptness by the Architect or Engineer through Galveston County's authorized Representative and in accordance with any schedule agreed upon. The Contractor shall make written request through Galveston County's authorized Representative to the Architect or Engineer for such interpretations. Such interpretations shall be consistent with and reasonably inferable from the Contract Documents. The Contractor shall execute and complete the Work in accordance with such interpretations.

3. Ownership and Use of Documents

- A. Unless otherwise provided in the Contract Documents, the Contractor will be furnished, free of charge, three (3) sets of Working Drawings and Project Manual reasonably necessary for the execution of the Work.
- B. All Drawings, Project Manual and copies thereof furnished by the Architect or Engineer are and shall remain his property. They are to be used only with respect to this Project and are not to be used on any other project. With the exception of one contract set for each party, such documents are to be returned or suitably accounted for to the Architect or Engineer on request at the completion of the Work. Submission or distribution to meet official regulatory requirements or for other purposes in connection with the Project is not to be construed as publication in derogation of the Architect or Engineer's common law copyright or other reserved rights.

4. Owner

- A. The Owner for this project is:

Galveston County
722 Moody, Suite 200
Galveston, Texas 77550

The Owner is the person or entity identified as such in the Agreement between the Owner and Contractor and is referred to throughout the Contract Documents as if singular in number and masculine in gender. The term "Owner" means the Owner or his authorized representative.

- B. Information and Services furnished by the Owner.
 - 1. The Owner will furnish all surveys describing the physical characteristics, legal limitations and utility locations for the site of the Project, and a legal description of the site.
 - 2. Except as provided in Article 9.2 of the Trade Contract the Owner will secure and pay for necessary approvals, easements, assessments and charges required for the construction, use, or occupancy of permanent structures or for permanent changes in existing facilities.
 - 3. Information or services under the Owner's control will be furnished by the Owner with reasonable promptness to avoid delay in the orderly progress of the Work.
 - 4. The Owner shall forward all instructions to the Contractors through Galveston County's authorized Representative.

5. Architect or Engineer

- A. Definition
 - 1. The Architect or Engineer for this project is: J. Dudley Anderson, County Architect
 - 2. The Architect or Engineer is the person lawfully licensed to practice Architecture or Engineering

Bayside Community Center

Bid Number	B161012
Bid Date	March 29, 2016
Bid Time	10:00 A.M.

or an entity lawfully practicing Architecture or Engineering identified as such in the Agreement between the Owner and Galveston County's authorized Representative and is referred to throughout the Contract Documents as if singular in number and masculine in gender. The term Architect or Engineer means the Architect or Engineer or his authorized representative.

3. Nothing contained in the Contract Documents shall create any contractual relationship between the Architect or Engineer and any Contractor.

B. Architect or Engineer Duties during Construction

1. The Architect or Engineer will be the interpreter of the requirements of the Drawings and Project Manual. The Architect or Engineer will, within a reasonable time, render such interpretations as are necessary for the proper execution of the progress of the work.
2. The Architect or Engineer shall interpret the requirements of Changes to the Work, and he shall decide all other questions of design intent in connection with the work.
3. The Architect or Engineer will recommend suspension of the Work whenever such suspension may be necessary to ensure proper execution of the Work.
4. All interpretations of the Architect or Engineer shall be consistent with the intent of and reasonably inferable from the Contract Documents and will be in writing or in the form of drawings. All requests for interpretations shall be directed through Galveston County's authorized Representative.
5. It shall be the responsibility of the Architect or Engineer to make interpretations and render opinions in regard to all claims of the Owner or Galveston County's authorized Representative involving questions of interpretation of the intent of the drawings and Project Manual.
6. Neither the Contractor, Galveston County's authorized Representative, nor the Owner shall be bound by any determination, interpretation or opinion of the Architect or Engineer if it is later determined that such is not in accord with the true intent of the contract documents. The party taking issue with the determination, interpretation or decision of the Architect or Engineer shall give the other party or parties, as the case may be, written notice of such fact within ten (10) days after the determination, interpretation or opinion is rendered by the Architect or Engineer. However, it is the intent of this paragraph that in the actual performance of the Work, the Contractor and/or Galveston County's authorized Representative shall, in the first instance, proceed in accordance with the instruction given by the Architect or Engineer unless the Owner and Galveston County's authorized Representative mutually agree that the Contractor and/or Galveston County's authorized Representative shall proceed otherwise.
7. The Architect or Engineer's decision in matters relating to artistic effect will be final if consistent with the Contract Documents.
8. The Architect or Engineer will have authority to reject Work which does not conform to the Contract Documents. Whenever, in his opinion, he considers it necessary or advisable for the implementation of the Contract Documents, he will have authority to require special inspection or testing of the Work in accordance with Subparagraph 19.B whether or not such Work be then fabricated, installed or completed. However, neither the Architect or Engineer's authority to act under this Subparagraph nor any decision made by him in good faith either to exercise or not to exercise such authority, shall give rise to any duty or responsibility of the Architect or Engineer to the Contractor, any Sub-Contractor, any of their agents or employees, or any other person performing any of the Work.
9. The Architect or Engineer will be the judge of the performance of the Work and will use his powers under the contract to enforce its faithful performance. The Architect or Engineer will determine the amount, quality, acceptability and fitness of all part of the work.
10. The Architect or Engineer will review or take other appropriate action upon Contractor's submittals such as Shop Drawings, Product Data and Samples, but only for conformance with the design concept of the Work and with the information given in the Contract Documents. Such action shall be taken with reasonable promptness so as to cause no delay. The Architect or Engineer's review of a specific item shall not indicate approval of an assembly of which the item is a component.

Bayside Community Center

Bid Number B161012
Bid Date March 29, 2016
Bid Time 10:00 A.M.

11. The Architect or Engineer along with Galveston County's authorized Representative will conduct site visits to determine the dates of Substantial Completion and final completion, will receive written warranties and related documents required by the Contract and assembled by the Contractor.
12. The Architect or Engineer will communicate with the Contractor through Galveston County's authorized Representative.

6. Galveston County's authorized Representative

A. Definition

1. Galveston County's authorized Representative or this project is: J. Dudley Anderson, County Architect.
2. It is the intent of these General Conditions to allow Galveston County's authorized Representative to direct and schedule the performance of all Work and the Contractors are expected to follow all such directions and schedules.

B. Administration of the Contract

1. Galveston County's authorized Representative will provide, as the Owner's authorized representative, the general administration of the Project as described herein and in Article 10 of the Agreement between Galveston County and Contractor.
2. Galveston County's authorized Representative will be the Owner's Construction Representative during construction until final payment and shall have the responsibility to manage the work of all Contractors.
3. Galveston County's authorized Representative shall have the authority to reject Work, which does not conform to the Contract Documents, and to require any Special Inspection and Testing in accordance with Subparagraph 20.B.
4. Galveston County's authorized Representative will prepare and issue Amendments (Changes in the Work) to the Contractors in accordance with Article 27.
5. Galveston County's authorized Representative, along with the Architect or Engineer, will conduct site visits to determine the dates of Substantial Completion and Final Completion, and will receive and review written warranties and related documents required by the Contract and assembled by the Contractor.

7. Contractor

A. Definition

1. Contractor is the person or entity identified as such, and is referred to throughout the Contract Documents as if singular in number and masculine in gender. The term Contractor means the Contractor or his authorized representative.
2. In the Project Manual, the word "contractor" shall mean and shall be interpreted as being the "Contractor" whose "scope of work" and Project Manual index includes that portion of the work. In these General Conditions the word "contractor" and/or "Contractor" shall mean and shall be interpreted as being "individually, each and every Contractor".
3. The Contractor shall at all times be considered to be an independent contractor, and will not hold itself or its employees out to be employees or agents of the County of Galveston.
4. The Contractor will retain full control over this contract and will not assign said contract without the prior written consent of the County.

B. Review of Contract Documents

1. The Contractor shall carefully study and compare the Contract Documents and shall at once report to Galveston County's authorized Representative any error, inconsistency or omission he may discover. If the Contractor performs any work without reporting any such error, inconsistency, or omission to Galveston County's authorized Representative or contrary to any laws, ordinances, rules, or regulations, and without such notice to Galveston County's authorized Representative, he shall assume full responsibility therefore and shall bear all costs attributable thereto.

C. Supervision and Construction Procedures

Bayside Community Center

Bid Number B161012
Bid Date March 29, 2016
Bid Time 10:00 A.M.

1. All work shall be performed and completed in a thorough, workmanlike manner and in accordance with the latest proven practices of the trade by thoroughly skilled and experienced workers.
2. The Contractor shall supervise and direct the Work, using his best skill and attention. He shall be solely responsible for all construction means, methods, techniques, sequences and procedures and for coordinating all portions of the Work under the Contract.
3. Galveston County's authorized Representative may reject any means, methods, techniques, sequences or procedures proposed by the Contractor, which might constitute or create a hazard to the Work, or to persons or property, or which will not provide Work in accordance with the Contract Documents
4. The Contractor shall be responsible to the Owner for the acts and omissions of his employees and all his Sub-Contractors and their agents and employees and other persons performing any of the Work under a contract with the Contractor.
5. Neither observations nor site visits, tests or approvals by persons other than the Contractor shall relieve the Contractor from his obligations to perform the Work in accordance with the Contract Documents. The Contractor shall do and be responsible for the correct laying out of the Work as per drawings and written instruction of Galveston County's authorized Representative including all necessary leveling and checking. The Contractor shall check the established grades and bench marks, and shall lay out all partition lines and other significant reference lines or points which will enable them to accurately place their boxes, openings, sleeves, conduits, pipe duct, controls, hangers, inserts and other devices. Subcontractors shall be responsible for laying out their Work from these reference points.

D. Labor and Materials

1. The Contractor is encouraged to use local labor, but not at the expense of poor workmanship and higher cost.
2. The Contractor and all Sub-Contractors shall not discriminate against any employee or applicant for employment because of race, color, sex, or national origin.
3. The Contractor shall post in conspicuous places, available to employees and applicants for employment, notices setting forth the policies of non-discrimination.
4. In the event of Contractor's non-compliance with the non-compliance clause of this Contract, the Contract entered into may be canceled in whole or part.
5. The Contractor shall at all times enforce strict discipline and good order among his employees and shall not employ on the Work any unfit person or anyone not skilled in the task assigned to him. Obnoxious behavior, possession, or consumption of alcoholic beverages or drugs on the premises is strictly prohibited. Violators shall be promptly discharged from the site.
6. The Contractor shall accept delivery, unload, store, protect, provide security, distribute and install any materials, systems and equipment furnished by others which are a part of the Work. The Contractor shall document receipt of such materials, systems and equipment on forms acceptable to Galveston County's authorized Representative.
7. Whenever the Contractor has knowledge that any actual or potential labor dispute is delaying or threatens to delay the timely performance of the work of this contract, the Contractor shall immediately give notice thereof to Galveston County's authorized Representative. The Contractor shall then confirm the notice, in writing, within 24 hours of the giving thereof and shall include all relevant information with respect thereto. No claims will be accepted for costs incurred as a result of jurisdictional or labor practices disputes.
8. The County is committed to maintaining an alcohol and drug free workplace. Possession, use or being under the influence of alcohol or controlled substances by the Contractor's employees while in the performance of this Contract is prohibited. Violation of this requirement shall constitute grounds for immediate termination of the Contract.

8. Warranty

- A. The Contractor warrants to the Owner that all materials and equipment furnished under this Contract will be new unless otherwise specified, and that all Work will be of good quality, free from faults and defects and in conformance with the Contract Documents. All Work not so conforming to these requirements,

Bayside Community Center

Bid Number B161012
Bid Date March 29, 2016
Bid Time 10:00 A.M.

including substitutions not properly approved and authorized, may be considered defective. If required by Galveston County's authorized Representative, the Contractor shall furnish satisfactory evidence as to the kind and quality of materials and equipment. This warranty is not limited by the provisions of Paragraph 28.B

- B. The warranty of materials, equipment and workmanship defined in 8.A is separate from, independent of, and in addition to any other guarantees in this contract or any other warranties required by the Contract Documents.
- C. The Contractor, prior to or at the time of substantial completion for the Work and during administrative closeout of the project, shall submit one copy of all specified warranties and guarantees to Galveston County's authorized Representative for review, approval and subsequent transmittal to the Architect or Engineer and Owner.
- D. Warranties and guarantees, including those specified in excess of the general one year guarantee shall be complete for all specific materials, systems, sub-systems, equipment, appliances and products specified and required by the Contract Documents.
- E. Warranties and guarantees shall clearly define what is to be guaranteed; the extent, terms, conditions, time and effective dates.
- F. Copies of the same warranties and guarantees shall be included in the "Owner's Maintenance Manual" as specified herein.
- G. Owner's Maintenance Manual: The Contractor, during the course of the work, shall maintain, coordinate and collect copies of warranties, guarantees, certificates, test results, installation drawings, manufacturer's maintenance and operations manuals, parts lists, and keying schedules and at the acceptance of the project, shall assemble this material into a manual and forward to Galveston County's authorized Representative for incorporation in the Operations and Maintenance Manual for the project..
- H. Warranties shall not commence to run until the Owner:
 - 1. Accepts the work for beneficial occupancy, and
 - a. is in possession of all the specified guarantee/ warranty documentation, and
 - b. has received the specified training for the operation and maintenance of the system/equipment .
- I. If prior to the acceptance of the Work the Owner occupies or uses any separate unit of the Work, the guarantee period shall, as to the unit so occupied or used, commence on the date of such occupancy or use, with the further provision that the Owner shall have first agreed in writing that the separate unit is complete to such a degree as to permit its use or occupancy and subject to subparagraph 8.H as applicable. No such separate unit shall be occupied or used by the Owner until such certificate has been given. Equipment and facilities, which have seasonal limitations on their operation, shall be guaranteed for one full year from the date of test and acceptance in writing by the Owner.
- J. If within any guarantee period, repairs or changes are required in connection with the guaranteed Work, as the result of the use of materials, equipment or workmanship, which are defective, or inferior, or not in accordance with the terms of the Contract, the Contractor shall, promptly, within 48 hours after receipt of notice from Galveston County's authorized Representative or Owner and without expense to the Owner or Construction Manager, commence and continue to effect such repairs or changes and:
 - 1. Place in satisfactory condition, in every particular, all of such guaranteed work and correct all defects therein.
 - 2. Make good all changes to the structure, site, equipment, or contents thereof, which, in the opinion of the Architect or Engineer, and Galveston County's authorized Representative is the result of the use of materials, equipment or workmanship, which are inferior, defective, or not in accordance with the terms of the Contract.
- K. Notifications by Owner or Galveston County's authorized Representative of defects shall stop the warranty time period. The guarantee or warranty period for that replaced or restored work shall be reinstated for the remaining time period, starting on the date of acceptance of the replaced or restored work.
- L. In any case, where in fulfilling the requirements of the Contract or of any guarantee embraced in or required thereby, the Contractor disturbs any work guaranteed under another contract, he shall restore such work to a condition satisfactory to the Architect or Engineer, and Galveston County's authorized Representative and guarantee such restored work to the same extent as it was guaranteed under such other

Bayside Community Center

Bid Number B161012
Bid Date March 29, 2016
Bid Time 10:00 A.M.

contract.

- M. If the Contractor after notice fails to proceed within 48 hours to commence and continue to comply with the terms of the guarantee, the Owner or Galveston County's authorized Representative may have the defect corrected in which case the Contractor and his surety shall be liable for all expenses incurred.
- N. All special guarantees or warranties applicable to definite parts of the Work that may be stipulated in the Project Manual or other papers forming a part of the Contract shall be subject to the terms of this Article during the first year of the life of such special guarantee.
- O. Nothing contained in this Article shall be construed to establish a period of limitation with respect to any other obligation which the Contractor might have under the Contract Documents.
- P. In the event the Work of the Contractor is to be modified by another Contractor, either before or after inspection, the first Contractor shall remain responsible in all respects under the warranty given in Article 8 and under any other warranties provided in the Company Documents or by law. However, the first Contractor shall not be responsible for any defects in material or workmanship introduced by the Contractor modifying its work. Both the first Contractor and the Contractor making the modifications shall each be responsible solely for the work done by each. The Contractor modifying the earlier work shall be responsible for any damage to or defect introduced into the Work which it is modifying.

9. Taxes

- A. The Contractor shall pay all sales, consumer, use and other similar taxes for the Work or portions thereof provided by the Contractor which are legally required at the time Bids are received, whether or not yet effective. Such taxes are included in the contract sum.
- B. Any taxes which are the responsibility of the Contractor, but are not paid by the Contractor, and which are subsequently assessed against and paid by the Owner shall be deducted by the Owner as an offset from the unpaid Contract Sum and any other amounts due to the Contractor. If the amount of such unpaid taxes exceeds the total of the unpaid Contract Sum and other amounts due to the Contractor, the Contractor agrees to pay the amount of such excess to the Owner.

10. Superintendent and key Personnel

- A. The Contractor shall employ a competent superintendent and necessary assistants who shall be in attendance at the Project site during the progress of the Work. The superintendent shall be satisfactory to Galveston County's authorized Representative, and shall not be changed except with the consent of Galveston County's authorized Representative, unless the superintendent proves to be unsatisfactory to the Contractor or ceases to be in his employ. The superintendent shall represent the Contractor and all communications given to the superintendent shall be as binding as if given to the Contractor. Important communications shall be confirmed in writing. Other communications shall be so confirmed on written request in each case.
- B. A duly authorized representative of the Contractor shall be available for emergency telephone communication from the Owner or Galveston County's authorized Representative on a 24-hour basis, seven days a week during the performance of the work.
- C. The Contractor shall identify the key personnel he intends to assign to the project, to Galveston County's authorized Representative within 48 hours after the Contractor has been notified to proceed. The Owner, acting through Galveston County's authorized Representative, reserves the right to approve the Contractor's proposed personnel, and anyone not so approved shall be immediately replaced by someone acceptable. If, in the course of construction, Galveston County's authorized Representative feels that it would be in his best interest to request a change in the Contractor's personnel, he may do so; and the Contractor shall immediately assign an acceptable replacement at no additional cost.

11. Drawings and Project manual at the site

- A. The Contractor shall maintain at the site for Galveston County's authorized Representative and Architect or Engineer one copy of all Drawings, Project Manual, Addenda, Bulletins, Amendments, and other Modifications, in good order and marked currently to record all changes made during construction. Including any changes in locations, sizing and arrangement of the various components of the Work or any other variations from the Drawings or Shop Drawings. The Contractor shall mark each drawing as the

Bayside Community Center

Bid Number B161012
Bid Date March 29, 2016
Bid Time 10:00 A.M.

Work shown thereon is completed in the field, revising any or adding lines, dimensions, elevations, depths, notes or any other information required to accurately record "As-Built" conditions. These drawings, marked to record all changes during construction, and approved Shop Drawings, Product Data and Samples shall be delivered to Galveston County's authorized Representative, for the Owner, upon completion of the Work.

- B. In addition to maintaining and delivering to Galveston County's authorized Representative those record Drawings required by Subparagraph 11.A the Contractor shall also prepare and submit to Galveston County's authorized Representative, upon completion of the Work "As-Built" Reproducible Drawings.

12. Use of Site

- A. The owner does not assume any responsibility for any materials, tools, or equipment stored on or about the site.
- B. The Contractor shall confine operations at the site to areas designated by Galveston County's authorized Representative, permitted by law, ordinances, permits and by the Contract Documents, and shall not unreasonably encumber the site with any materials or equipment. The Contractor shall not use any of the existing Owner's facilities, such as, toilets, cafeteria, parking areas, power hookup, etc., except with the Galveston County's authorized Representative's written approval. The Contractor shall not, at any time, block or restrict access to the site.
- C. The Contractor shall coordinate all of his operations with Galveston County's authorized Representative and obtain his approval before using any portion of the project site and the Contractor shall comply with the Galveston County's authorized Representative's Site Utilization Plan.
- D. The roads, sidings and other transportation facilities at the site, where work under the Contract is being performed, are for the general use and convenience of the Owner. If Contractors are permitted to use them, they must conform to the regulations of the local authorities. If the work of a Contractor requires that such facilities be temporarily discontinued, after obtaining Galveston County's authorized Representative's approval, the work must be done expeditiously and he shall provide and maintain proper warnings and detour signs at all pedestrian and vehicular closures, intersections, and along detours, directing traffic around closed portions of roadways. He shall, at his own expense, wherever necessary or required, provide and maintain fences, temporary roadways, temporary cross signs, watchmen, warning lights and take such other precautions as may be necessary to protect life any way by his act or neglect. All barricades and obstructions shall be illuminated at night, and all lights shall be kept on from one half hour before sunset, until one-half-hour after sunrise.
- E. On-site storage space for Contractor's field office trailer, sheds, materials, tools, equipment, and supplies must be coordinated with and approved by Galveston County's authorized Representative in advance. Contractor's materials, equipment, tools and supplies shall be moved at no cost if their location obstructs or impedes the work of others.
- F. Galveston County's authorized Representative will provide site survey, selected baselines and benchmarks.
- G. The Contractor shall not disturb existing monuments and markers at the site. Should monuments, markers, or both be disturbed by the Contractor, he shall bear the cost of a licensed surveyor engaged by Galveston County's authorized Representative for the purpose of relocating such monuments or markers.
- H. Each Contractor shall lay out his work and shall be responsible for the accuracy of all lines, elevations and measurements, grading, utilities, and other work executed by him under his Trade Contract. He must exercise proper precaution to verify figures shown on drawings before laying out work and will be held responsible for any error resulting from his failure to exercise such precaution.

13. Communications

- A. The Contractor shall forward all communications to the Owner and Architect or Engineer through Galveston County's authorized Representative.
- B. The Contractor shall promptly return telephone calls or respond to any other form of communication initiated by Galveston County's authorized Representative. Failure to promptly do so shall be considered lack of performance on the part of the Contractor.
- C. All written correspondence to Galveston County's authorized Representative shall be dated, and signed by the Contractor or his authorized representative.

Bayside Community Center

Bid Number B161012
Bid Date March 29, 2016
Bid Time 10:00 A.M.

- D. Written notice shall be deemed to have been duly served if delivered in person to the individual or member of the firm or entity or to an officer of the corporation for whom it was intended, or if delivered at or sent by registered or certified mail to the last business address known to him who gives the notice.

14. Sub-Contractors

A. Definition

1. A Sub-Contractor is a person or entity who has a direct or indirect contract with a Contractor to perform any of the Work at the site. The term Sub- Contractor is referred to throughout the Contract Documents as if singular in number and masculine in gender and means a Sub-Contractor or his authorized representative.
2. Nothing in the contract documents shall create any contractual relationship between the Owner, the Architect or Engineer or Galveston County's authorized Representative and any Sub-Contractor of the Contractor.

B. Award of Sub-trade Contracts and other Contract for Portions of the Work

1. Unless otherwise required by the Contract Documents the Contractor shall furnish to Galveston County's authorized Representative in writing, for acceptance by the Owner and Galveston County's authorized Representative in writing, the names of the persons or entities (including those who are to furnish materials or equipment fabricated to a special design) proposed for each of the principal portions of the Work. The Contractor is encouraged to use Local vendors wherever possible. Galveston County's authorized Representative will promptly reply to the Contractor in writing if either the Owner or Galveston County's authorized Representative, after due investigation, has reasonable objection to any such proposed person or entity. Failure of the Owner or Galveston County's authorized Representative to reply shall constitute notice of no reasonable objection.
2. The Contractor shall not contract with any such proposed person or entity to whom the Owner or Galveston County's authorized Representative has made reasonable objection under the provision of Subparagraph 14.B.1. The Contractor shall not be required to contract with anyone to whom he has a reasonable objection.
3. If the Owner or Galveston County's authorized Representative refuses to accept any person or entity on a list submitted by the Contractor in response to the requirements of the Contract Documents, the Contractor shall submit an acceptable substitute; however, no increase in the Contract Sum shall be allowed for any such substitution.
4. The Contractor shall make no substitution for any Sub-Contractor, person or entity previously selected if the Owner or Galveston County's authorized Representative makes reasonable objection to such substitution.

C. Sub-trade Contractual Relations

1. By an appropriate written agreement, the Contractor shall require each Sub-Contractor to the extent of the work to be performed by the Sub-Contractor, to be bound to the Contractor by the terms of the Contract Documents, and to assume toward the Contractor all the obligations and responsibilities which the Contractor, by these documents, assumes toward the Owner, Galveston County's authorized Representative, or the Architect or Engineer. Said agreement shall preserve and protect the rights of the Owner, Galveston County's authorized Representative and the Architect or Engineer under the Contract Documents with respect to the work to be performed by the Sub-Contractor so that the subcontracting thereof will not prejudice such rights, and shall allow to the Sub-Contractor, unless specifically provided otherwise in the Contractor agreement, the benefit of all rights, remedies and redress against the Contractor that the Contractor, by these Documents, has against the Owner.
2. Where appropriate, the Contractor shall require each Sub- Contractor to enter into similar agreements with his Sub-Contractors. The Contractor shall make available to each proposed Sub-Contractor, prior to the execution of the Sub-trade contract, copies of the Contract Documents to which the Sub- Contractor will be bound by this Paragraph 14.C.1 and shall identify to the Sub-Contractor any terms and conditions of the proposed Sub-trade contract which may be at a

Bayside Community Center

Bid Number	B161012
Bid Date	March 29, 2016
Bid Time	10:00 A.M.

variance with the Contract Documents. Each Sub-Contractor shall similarly make copies of such Documents available to his Sub-Contractors.

15. Separate Contractors

- A. The Contractor shall afford Galveston County's authorized Representative and other Contractors reasonable opportunity for the introduction and storage of their materials and equipment and the execution of their work, and shall connect and coordinate his Work with others under the general direction of Galveston County's authorized Representative.
- B. If any part of the Contractor's Work depends, for proper execution or results, upon the work of Galveston County's authorized Representative or any separate Contractor, the Contractor shall, prior to proceeding with the Work, promptly report to Galveston County's authorized Representative any apparent discrepancies of defects in such work that render it unsuitable for such proper execution and results. Failure of the Contractor so to report shall constitute an acceptance of the other Contractor's or Galveston County's authorized Representative's work as fit and proper to receive his Work, except as to latent defects which may subsequently become apparent in such work by others.
- C. Copies of Drawings and Project Manual relating to these separate contracts will be available to the Contractor, upon request, for his information in carrying out the above provisions. The Contractor shall be held responsible for any damage or misfit resulting from his neglect to comply with the foregoing.
- D. All Contractors on the project shall have equal rights on the premises for the performance of their work, but shall follow the sequence established by the progress schedule and/or instruction issued by Galveston County's authorized Representative.
- E. If the Contractor notifies Galveston County's authorized Representative, in writing, that another contractor on this project is failing to coordinate his work with the Work of this contract, as directed, Galveston County's authorized Representative will promptly investigate the charge. If he finds it to be true, he will promptly issue such directions to the other contractor with respect thereto as the situation may require. Galveston County's authorized Representative or Owner shall not, however, be liable for any damages suffered by this Contractor by reason of the other contractor's failure to promptly comply with the directions so issued by Galveston County's authorized Representative or by reason of another contractor's default in performance; it being understood that Galveston County's authorized Representative does not guarantee the responsibility or continued efficiency of any contractor. Any costs caused by defective or ill-timed work shall be borne by the party responsible therefore.
- F. Should the Contractor wrongfully cause damage to the work or property of the Owner, any separate Contractor or other Contractor, the Contractor shall, upon due notice, promptly attempt to settle with the Owner, the separate Contractor or other Contractor by agreement, or otherwise resolve the dispute. If such separate Contractor or other Contractor sues the Owner on account of any damage alleged to have been caused by the Contractor, the Owner shall notify the Contractor who shall defend such proceedings at the Contractor's expense, and if any judgment or award against the Owner arises therefrom, the Contractor shall pay or satisfy it and shall reimburse the Owner for all attorney's fees and court costs which the Owner has incurred.
- G. Should the Contractor sustain any damage through any act or omission of any other contractor having a contract with the Owner for the performance of work upon the site or of work which may be necessary to be performed for the proper prosecution of the work to be performed hereunder, or through any act or omission of a subcontractor of such contractor, the Contractor shall have no claim against the Owner, Architect or Engineer, Galveston County's authorized Representative or the Owner's consultants for such damage, but shall have a right to recover such damage from the other contractor under the provision similar to the following provisions that have been or will be inserted in the contracts with such other contractors.
- H. Should any other contractor having or who shall hereafter have a contract with the Owner for the performance of work upon the site sustain any damage through any act or omission of a Sub-Contractor of the Contractor, the Contractor agrees to reimburse such other contractor for all such damages and to indemnify and hold the Owner, Architect or Engineer and Galveston County's authorized Representative harmless from all claims.
- I. The Contractor shall indemnify and hold the Owner, Architect or Engineer and Galveston County's authorized Representative harmless from any and all claims or judgments for damages and from costs and

Bayside Community Center

Bid Number B161012
Bid Date March 29, 2016
Bid Time 10:00 A.M.

expenses to which the Owner and/or Galveston County's authorized Representative may be subjected or which either may suffer or incur by reason of the Contractor's failure to comply with the Galveston County's authorized Representative's directions promptly. If the Contractor installs any work prior to proper coordination, or in such manner as to cause interference with work of others, he shall arrange for removal of or arrange for necessary modifications to the work. Any such action is subject to the approval of Galveston County's authorized Representative and shall be at no additional cost.

- J. The Contractor shall cooperate with the Owner, Architect or Engineer and Galveston County's authorized Representative and other Contractors working on this project in order to avoid interference, inconvenience or damage. To aid in avoiding conflicts, the Contractor, without additional charge, shall make all reasonable modifications in the work as may be directed by Galveston County's authorized Representative. In the event of the Contractor's operations causes any damage, interference, or inconvenience to work being carried out under any other Trade Contract, the Contractor shall restore, replace, rectify, or otherwise make good any damage to the satisfaction of Galveston County's authorized Representative or to the other Contractors. Should the responsible Contractor fail to comply with this provision, the work will be done by others at the expense of the responsible Contractor.
- K. Contractor agrees that he has become familiar with the site, has reviewed the plans and Project Manual covering the work of his and other trades and thereby accepts responsibility for all necessary coordination of his Work with the work of other trades affected.

16. Governing Law and Venue

- A. The Contract shall be governed by the law of the place where the Project is located. Any action arising from or relating from this Contract shall be instituted in a court of competent jurisdiction in Galveston County, Texas.
- B. Contractor shall at all times observe and comply with all Federal, State and Local Laws, ordinances and regulations which in any manner effect the contract or the work.
- C. Contractor shall comply with all city, county, and state codes, laws, and ordinances in force at the time of award of Contract and applicable to such work.
- D. Contractor shall obtain, at Contractor's own expense such permits, certificates, and licenses as may be required in the performance of the specified work.
- E. Contractor shall be responsible for obtaining and furnishing all necessary permits and licenses, City, County, State or Federal as are required for the performance of this Contract.

17. Claims for Damages

- A. Should either party to the Trade Contract suffer injury or damage to person or property because of any act or omission of the other party or of any of his employees, agents or others for whose acts he is legally liable, claim shall be made, in writing, to such other party within a reasonable time after the first observance of such injury or damage.
- B. Notwithstanding the event of any claim, dispute, or other matter in question arising out of or relating to this Agreement or the breach thereof, the Contractor shall carry on the work and maintain the Substantial Completion Date and Galveston County's authorized Representative shall continue to make payments in accordance with this Agreement.
- C. All damage to the work from the action of the elements, or from any unforeseen circumstances in the prosecution of the work shall be repaired by the Contractor at his own costs.

18. Indemnification

The Contractor shall agree to assume all risks and responsibility for, and agrees to indemnify, defend, and save harmless, the County of Galveston, its elected and appointed officials and department heads, and its agents and employees from and against all claims, demands, suits, actions, recoveries, judgments, and costs and expenses including reasonable attorney's fees for the defense thereof in connection therewith on account of the loss of life, property or injury or damage to the person which shall arise from Contractor's operations under this Contract, its use of County facilities and/or equipment or from any other breach on the part of the Contractor, its employees, agents or any person(s) in or about the County's facilities with the expressed or

Bayside Community Center

Bid Number B161012
Bid Date March 29, 2016
Bid Time 10:00 A.M.

implied consent of the County. Contractor shall pay any judgment with cost which may be obtained against Galveston County resulting from contractor's operations under this Contract.

Contractor agrees to indemnify and hold the County harmless from all claims of subcontractors, laborers incurred in the performance of this contract. Contractor shall furnish satisfactory evidence that all obligations of this nature herein above designated have been paid, discharged or waived. If Contractor fails to do so, then the County reserves the right to pay unpaid bills of which County has written notice direct and withhold from Contractor's unpaid compensation a sum of money reasonably sufficient to liquidate any and all such lawful claims.

19. Rights and Remedies

- A. The duties and obligations imposed by the Contract Documents and the rights and remedies available thereunder shall be in addition to and not a limitation of any duties, obligations, rights and remedies otherwise imposed or available by law.
- B. No action or failure to act by the Owner, Construction Manager, Architect or Engineer or Contractor shall constitute a waiver of any right or duty afforded any of them under the Contract Documents, nor shall any such action or failure to act constitute an approval of or acquiescence in any breach thereunder, except as may be specifically agreed in writing.

20. Tests

- A. If the Contract Documents, laws, ordinances, rules, regulations or order of any public authority having jurisdiction require any portion of the Work to be inspected, tested or approved, the Contractor shall give Galveston County's authorized Representative timely notice of its readiness so the Architect or Engineer and Galveston County's authorized Representative may observe such inspection, testing or approval. The Contractor shall bear all costs of such site visits, tests or approvals unless otherwise provided.
- B. If the Architect or Engineer or Galveston County's authorized Representative or Owner determines that any Work requires special inspection, testing or approval which Subparagraph 19.A does not include, he will, through Galveston County's authorized Representative, instruct the Contractor to order such special inspection, testing or approval and the Contractor shall give notice as in Subparagraph 19.A. If such special inspection or testing reveals a failure of the work to comply with the requirements of the Contract Documents, the Contractor shall bear all costs thereof, including compensation for the Architect or Engineer's and Galveston County's authorized Representative's additional services made necessary by such failure. If the Work complies, the Owner shall bear such costs and an appropriate Amendment shall be issued.
- C. Required certificates of inspection, testing or approval shall be secured by the Contractor and promptly delivered by him through Galveston County's authorized Representative to the Architect or Engineer.
- D. If the Architect or Engineer or Galveston County's authorized Representative is to observe the site visits, tests or approvals required by the Contract Documents, he will do so promptly and, where practicable, at the source of supply.
- E. Neither the observations of the Architect or Engineer or Galveston County's authorized Representative, in their Administration of the Construction Contract, nor site visits, test or approvals by persons other than the Contractor, shall relieve the Contractor from his obligation to perform the Work in accordance with the Contract Documents.
- F. The Contractor shall deliver test samples of any of the materials specified in any of the Sections of his Specifications to an independent testing laboratory selected and approved by the Owner and Construction Manager, if so required. This may apply to materials proposed for use, materials already delivered to the job, or materials already incorporated into the construction.
- G. The Contractor shall maintain a file of all test reports. At the completion of the project, these reports will be submitted as an Appendix to the Operations and Maintenance Manual described above.
- H. Any materials, which fail to meet the requirements of these Specifications, shall not be used whether or not previously approved by the Architect or Engineer. If they have been delivered to the job, they shall be removed. If they have already been incorporated into the construction, Galveston County's authorized Representative or the Architect or Engineer may order them removed, or, at the discretion of the Owner, through Galveston County's authorized Representative they may be permitted to remain in place providing

Bayside Community Center

Bid Number B161012
Bid Date March 29, 2016
Bid Time 10:00 A.M.

the Contractor agrees to a proper deduction from the contract sum.

- I. The services of a testing and inspection engineer selected by the Owner and Architect or Engineer shall be provided and paid for by the Owner for the tests required in the paragraph 20.F unless specifically stated otherwise or due to deficient work.

21. Interest

- A. Payments due and unpaid under the Contract Documents shall bear interest in accordance with applicable law.

22. Time

- A. Definitions
1. Unless otherwise provided, the Contract Time is the period of time allotted in the Contract Documents for the Substantial Completion of the Work as defined in Subparagraph (22.A.3) including authorized adjustments thereto.
 2. The date of commencement of the Work shall be the date of the Notice to proceed.
 3. The date of Substantial Completion of the Work, for each Contractor, or designated portion thereof is the Date certified by the Architect or Engineer when construction is sufficiently complete, in accordance with the Contract Documents, so the Owner can occupy or utilize the Work or designated portion for the use for which it is intended.
 4. The term day as used in the Contract Documents shall mean calendar day unless otherwise specifically designated.
- B. Progress and Completion
1. With the Galveston County's authorized Representative's approval, the Contractor shall suspend any work that may be subject to damage by climatic conditions. Under such conditions, the Contractor shall take measures to protect his work and to minimize the impact on progress of the work.
- C. Delays and Extension of Time
1. If the Contractor is delayed at anytime in the progress of the Work by any act or neglect of the Owner, Construction Manager, or the Architect or Engineer, or by any employee of either, or by any separate contractor employed by the Owner, or by changes ordered in the Work, or by labor disputes, fire, unusual delay in transportation, adverse weather conditions not reasonably anticipatable, unavoidable casualties or any causes beyond the Contractor's control, and without his fault or negligence, or by any other cause which Galveston County's authorized Representative determines may justify the delay, then the Contract Time shall be extended by Contract Amendment for such reasonable time as Galveston County's authorized Representative may determine.
 2. Any claim for extension of time shall be made in writing to Galveston County's authorized Representative not more than ten (10) days after the commencement of the delay; otherwise, it shall be waived. Any claim for extension of time shall state the cause of the delay and the number of days extension requested. If the cause of the delay is continuing, only one claim is necessary, but the Contractor shall report the termination of the cause for the delay within ten (10) days after such termination; otherwise, any claim for extension of time based upon that cause shall be waived.
 3. In the event of a delay attributable in part to the Contractor and in part to causes or parties for which the Contractor is not responsible, then provided the Contractor has given proper and timely notice hereunder, the delay shall be equitably apportioned among the parties causing the delay and the Contractor shall remain liable for the portion not so excused.
 4. If no agreement is made stating the dates upon which interpretations shall be furnished, then no claim for delay shall be allowed on account of failure to furnish such interpretations until fifteen days after written request is made for them, and not then unless such claim is reasonable.
 5. No claim for an increase in the Contract Sum for either acceleration or delay will be allowed for extensions of time pursuant to this Paragraph 22.C or for other changes in the Construction Schedules.

Bayside Community Center

Bid Number B161012
Bid Date March 29, 2016
Bid Time 10:00 A.M.

6. There are no Liquidated damages for this project.
7. The permitting of the Contractor or the surety on the performance bond to proceed to complete any work or any part of it after the date of completion or after the date to which the time for completion may have been extended, shall in no way operate as a waiver on the part of the Owner of any of its rights hereunder.
8. Neither the Owner nor the Architect or Engineer nor Galveston County's authorized Representative shall have liability to the Contractor or to any other Contractor or Sub-Contractor for delay, hindrance, or interference in the performance of the Work, however caused, except for delay or hindrance resulting from active interference of Owner or its representatives in such Contractor's execution of the Work, and except for delay or hindrance resulting from defective plans and specifications not reasonably discoverable by the Contractor prior to Contract award.
9. The Contractor shall be liable to the Owner for any other damages sustained as the result of the Contractor's refusal or failure to perform the Work, provided, however, that such refusal or failure is not the result of a justifiable delay as defined in Subparagraph 22.C.1.

23. **Payments and Completion**

A. **Progress Payments**

1. Contractor shall make application to Owner by submittal of Pay Request to Galveston County's authorized Representative for payment utilizing forms provided by Owner for that purpose. Contractor shall state the percentage or the limits of the work performed and request payment for the amount of acceptable work performed. Applications for payment shall be made monthly by Contractor on a regular date set by Galveston County's authorized Representative.
2. Upon approval of the request for payment by Galveston County's authorized Representative and Architect or Engineer the Owner shall then pay the Contractor on or before 30 days thereafter, the total amount of the request, less 5% of the amount thereof, which 5% shall be retained until final payments, and further less all previous payments, and further less all further sums that may be retained by the County under the terms of this agreement
3. Upon the attainment of substantial completion, payment will be made so that the sum of all payments made under the contract equals Ninety Five Percent (95%) of the total contract amount
4. Galveston County's authorized Representative may request As-Built Drawings, schedule updates, payrolls for all labor, and other data supporting payment to subcontractors and/or materials suppliers before processing the requisition..
5. Except in case of bona fide disputes, or where the Contractor has some other justifiable reason for delay, the Contractor shall pay for all transportation and utility services not later than the end of the calendar month following that in which services are rendered and for all materials, tools and other expendable equipment to the extent of ninety five percent (95) of the cost thereof not later than the end of the calendar month following that in which such materials, tools and equipment are delivered at the site of the Project and in compliance with Texas Law. The Contractor shall pay to each of his Sub-Contractors, not later than the end of the calendar month in which each payment is made to the Contractor, the representative amount allowed the Contractor on account of the work performed by his trade subcontractors, to the extent of each Sub-Contractor's interest therein and in compliance with Texas Law. The Contractor shall, by an appropriate agreement with each Sub-Contractor, also require each Sub-Contractor to make payments to his suppliers and Sub-Contractors in a similar manner.
6. Materials, equipment and associated components that are in compliance with the approved submittals and will be incorporated into the structure, may be taken into consideration in computing progress payments, provided the material is delivered on the project site, or is delivered to the Contractor and the material is properly stored in a warehouse, storage yard or similar suitable place as may be approved by Galveston County's authorized Representative. The Contractor shall remain responsible for all such stored materials.
 - a. Payment for materials, equipment and associated components stored on-site shall be 100% of a valid invoice less 5% retainage, indicating the unit quantity, description of the material or equipment and cost.

Bayside Community Center

Bid Number B161012
Bid Date March 29, 2016
Bid Time 10:00 A.M.

- b. Payment for materials, equipment and associated components stored off-site shall be 100% percent of a valid invoice, less 5% retainage, indicating the unit quantity, description of the material or equipment and costs. Before such payment is made, the Contractor shall furnish Galveston County's authorized Representative with a certified statement giving the exact location of the materials or equipment, that such material or equipment is properly stored and protected, and that it will not be diverted for use or installation at a different project. The Contractor shall furnish Galveston County's authorized Representative properly executed bills of sale and a certificate of insurance coverage for the material upon which payment is being made.
 7. All material and work covered by payments made shall thereupon become the sole property of the Owner but Contractor shall remain responsible to protect same.
- B. Payments withheld
1. Galveston County's authorized Representative may decline to approve an Application for Payment if in his opinion the application is not adequately supported. If the Contractor and Galveston County's authorized Representative cannot agree on a revised amount, Galveston County's authorized Representative shall process the Application for the amount he deems appropriate. Galveston County's authorized Representative may also decline to approve any Applications for Payment or, because of subsequently discovered evidence or subsequent site visits, he may nullify in whole or in part any approval previously made to such extent as may be necessary in his opinion because of:
 - a. defective work not remedied;
 - b. third party claims filed or reasonable evidence indicating probable filing of such claims;
 - c. failure of the Contractor to make payments properly to Sub-Contractors or for labor, materials or equipment;
 - d. reasonable evidence that the Work cannot be completed for the unpaid balance of the Contract Sum;
 - e. damage to the Owner, or another contractor working at the Project;
 - f. reasonable evidence that the Work will not be completed within the Contract Time; or
 - g. persistent failure to carry out the Work in accordance with the Contract Documents.
 - h. no payment shall be made to the Contractor until certificates of insurance or other evidence of compliance by the Contractor with all the requirements of Article 30 have been filed with the Owner and Galveston County's authorized Representative. Further, no payments on the basis of work performed by a Sub-Contractor shall be paid until copies of all bonds required and any certificates of insurance required of the Sub-Contractors under Article 30 have been filed with the Owner and Construction Manager.
 - i. the filing of a claim against the Project, which claim, is caused by the act or inaction of the Contractor or his Sub-Contractors;
 - j. refusal to follow the Project Safety Program issued as a contract document or Contractors Safety Program;
 - k. failure to maintain record drawings as specified;
 - l. failure to comply with HUB requirements;
 - m. failure to comply with EEO Requirements;
 - n. failure to properly submit a response to an RFP (Request for Proposal) within thirty (30) days of receipt thereof.
 2. When the above grounds in subparagraph 22.B.1 are removed, payment shall be made for amounts withheld because of them.
- C. Failure of Payment
1. If the Contractor is not paid and is approved for payment by Galveston County's authorized Representative and has become due and payable, then the Contractor may, upon seven additional days written notice to the Owner and Construction Manager, stop the Work until payment of the amount due has been received. The Contract Sum shall be increased by the amount of the

Bayside Community Center

Bid Number B161012
Bid Date March 29, 2016
Bid Time 10:00 A.M.

Contractor's reasonable costs of shutdown, delay and startup, which shall be effected by appropriate Contract Amendment in accordance with Paragraph 27.C.

D. Substantial Completion

1. On or about the end of the project, the Contractor shall perform the following in order to achieve Substantial Completion.
 - a. When in the opinion of the Contractor the work is substantially complete,.
 - b. The Contractor shall notify Galveston County's authorized Representative, in writing, that the work will be ready for review and test on a definite date.
 - c. Notice shall be given at least fifteen (15) days in advance of said date.
 - d. Galveston County's authorized Representative shall forward the notice to the Architect or Engineer and will attach his endorsement as to whether or not he concurs with the Contractor's statement that the work will be ready for review or test on the date given, but such endorsement shall not relieve the Contractor of his responsibility in the matter.
 - e. If the Architect or Engineer concurs that the Work will be ready for review or test on the date given, the Architect or Engineer and Galveston County's authorized Representative will make such review after Contractor submits a thorough list of items to be completed or corrected (Punch List).
 - f. The Contractor is required to furnish access for the substantial Completion review.
 - g. Contractor shall have all systems fully functional and operational for the review.
 - h. The Architect or Engineer/Engineer and Galveston County's authorized Representative will inspect the project utilizing the Contractor's prepared Punch List, noting completed or incomplete items, and prepare a supplemental list of items that have been omitted or incomplete items that were not previously noted. The Architect or Engineer, at his discretion, may attend and assist in the preparation of the Contractor's punch list.
 - i. Contractor completes corrections, and Architect or Engineer and Galveston County's authorized Representative re-inspect to establish Date of Substantial Completion.
Note: Any items remaining on date of Substantial Completion are appended to Certificate (AIA G-704).
 - j. Architect or Engineer may issue a Certificate of Substantial Completion at this point.
 - k. Certain warranties and insurances are dependent on the date of Substantial Completion from the above certification. No other date of Substantial Completion will be recognized by the Owner or Contractor.
 - l. After the Certificate of Substantial Completion has been executed by all parties, it is returned to Galveston County's authorized Representative. Items on the appended Punch List are to be completed or corrected within the time limits established in the Certificate of Substantial Completion.
2. The project may be considered substantially complete if the work has been completed to the point where the work can be utilized for the general purpose for which it was undertaken and has been certified by the Architect or Engineer.
3. Progress payment request may not be submitted for more than 95% of the overall contract value at Substantial Completion.

E. Final Completion and Payment

1. Contractor shall be responsible for and make good without extra charge any defects due to faults in labor or material on all parts of the Contract for one year (and longer where noted) after Substantial Completion of the Work as defined in Article 22 in the General Conditions.
2. Property not in the Contract but damaged due to defects, shall be repaired or replaced by the Contractor without extra charge.
3. When notified by the Owner or Architect or Engineer that a defect exists and there is a doubt that the defect might be normal maintenance or a result of lack of normal maintenance, the Owner will send a representative with the Contractor's representative to determine responsibility. Owner will not pay for such service calls if the defect is judged to be normal maintenance or a result of a lack of normal maintenance.

Bayside Community Center

Bid Number B161012
Bid Date March 29, 2016
Bid Time 10:00 A.M.

4. Neither the Final Certificate of Payment or payment of same, nor provision in the Contract Documents shall relieve the Contractor of the responsibility for negligence or faulty materials or workmanship within the extent and period provided by law and upon written notice, he shall remedy any defects due thereto and pay all expenses for any damage to other Work resulting there from. This guarantee of Work shall not relieve the Contractor of obligations of any Work not according to Plans and Specifications regardless of time of discovery.
5. No final payment will be considered until all deficiencies listed with the Certificate of Substantial Completion have been remedied.
6. Contractor submits written notice to Galveston County's authorized Representative that work is ready for final review and acceptance, and shall specifically note each item on the Punch List as being complete or the status of any incomplete item.
7. Notice shall be given at least fifteen (15) days in advance of said date.
8. Galveston County's authorized Representative shall forward the notice to the Architect or Engineer and will attach his endorsement as to whether or not he concurs with the Contractor's statement that the work will be ready for final review or test on the date given, but such endorsement shall not relieve the Contractor of his responsibility in the matter.
9. If the Architect or Engineer concurs that the Work will be ready for final review or test on the date given, the Architect or Engineer and Galveston County's authorized Representative will make such review with the Contractor and Owner.
10. The Contractor is required to furnish access for the final review.
11. Neither application for final payment nor for the remaining retained percentage shall be made until the Contractor submits to Galveston County's authorized Representative the following:
 - a. an affidavit that all payrolls, bills for materials and equipment, and other indebtedness connected with the Work for which the Owner or his property might in any way be responsible, have been paid or otherwise satisfied,
 - b. consent of surety, if any, to final payment,
 - c. properly executed " General Release and Claim Waiver and General Guarantee" on forms acceptable to Galveston County's authorized Representative,
 - d. specified warranties and guarantees,
 - e. other data establishing payment or satisfaction of all such obligations, such as receipts, releases and waivers of bond claims arising out of the Contract, to the extent and in such form as may be designated by the Owner. If any Sub-Contractor refuses to furnish a release or waiver required by the Owner the Contractor may furnish a bond satisfactory to the Owner to indemnify them against any such claim. If any such claim remains unsatisfied after all payments are made, the Contractor shall refund to the Owner or Galveston County's authorized Representative all moneys that the latter may be compelled to pay in discharging such claim, including all costs and reasonable attorneys' fees.
12. Contractor submits Final Application for Payment and a Certificate of Compliance, which indicates the following:
 - a. All Permit Numbers
 - b. Utility Release Dates
 - c. The building has been duly inspected and found to comply with all code requirements and ordinances.
 - d. A Certificate of Occupancy has been issued.
 - e. Architect and Engineer (with Owner's authorized Representative) make final inspection
 - f. Contractor submits additional final items:
 - g. Consent of Surety to Final Payment (AIA G-707)
 - h. Contractor's Affidavit of Payment of Debts and Claims (AIA G-706)
 - i. Contractor's Affidavit of Release of Liens (AIA G-706A with contractors, subcontractors and suppliers separate releases)
 - j. Contractor's Guarantee
 - k. Subcontractors' Guarantees.
 - l. Maintenance and Instruction Manuals. All manuals will contain an index listing the information submitted. The index sections will be divided and identified by tabbing each section as listed in the index.

Bayside Community Center

Bid Number B161012
Bid Date March 29, 2016
Bid Time 10:00 A.M.

- m. Record Drawings (reproducible sepias)
 - n. Final List of Subcontractors (AIA G-805)
 - o. Affidavits from Contractor, Subcontractors, and suppliers stating that no asbestos products have been installed in this project.
 - p. Furnish written warranties to the Owner including specific items in each product warranty stipulated for individual sections.
 - q. Documents identified as "affidavit" must be notarized.
 - r. Contractor has documented the turnover of spare stock of materials, spare parts accessories and special tools to the Owner through Galveston County's authorized Representative,
 - s. Final Cleaning:
 - a. The work area shall be thoroughly cleaned inside and outside. Cleaning includes removal of smudges, marks, stains, fingerprints, soil, dirt, spots, dust, lint, and other foreign materials from finished and exposed surfaces.
 - b. Remove all temporary facilities.
13. If the Work is found acceptable under the Contract Documents and the Contract fully performed, and Galveston County's authorized Representative, upon receipt of a correct final Application for Payment, recommends to the Owner that such payment be made.
14. The making of final payment shall constitute a waiver of all claims by the Owner or Galveston County's authorized Representative except those arising from:
- a. unsettled claims;
 - b. faulty or defective Work appearing after Substantial Completion;
 - c. failure of the Work to comply with the requirements of the Contract Documents; or
 - d. terms of any special warranties required by the Contract Documents.
15. The acceptance by the Contractor of the final payment shall be, and operate as, a release to the Owner and to Galveston County's authorized Representative of all claims and of all liability to the Contractor for all things done or furnished in connection with this Contract.
16. Final Payment to Contractor **does not include** payment of **retainage**. Payment of **retainage will be made after project completion and in accordance** with Article 3 of Agreement between Galveston County and Contractor.
- 24. Protection of Persons and Property**
- A. Safety Precautions and Programs
- 1. The Contractor expressly undertakes, both directly and through his Sub-Contractors to take every precaution at all times for the protection of persons, including employees and property. The Contractor shall be responsible for initiating, maintaining and supervising all safety precautions and programs in connection with the Work.
 - 2. If the Contractor fails to maintain the safety precautions required by law or directed by Galveston County's authorized Representative, Galveston County's authorized Representative may take such steps as necessary and charge the Contractor therefore.
 - 3. The failure of Galveston County's authorized Representative to take any such action shall not relieve the Contractor of his obligations in Subparagraph 24.A.1.
- B. Safety of Persons and Property
- 1. The Contractor shall submit his safety program to Galveston County's authorized Representative prior to mobilizing to the job, and shall be responsible for the safety, efficiency and adequacy of his plant, appliances and methods and for any damage, which might result from failure or improper construction, maintenance, or operation. The Contractor shall provide a safety report to Galveston County's authorized Representative on a weekly basis.
 - 2. The Contractor shall take all reasonable precautions for the safety of, and shall provide all reasonable protection to prevent damage, injury or loss to:
 - a. all employees on the work and all other persons who may be affected thereby;
 - b. all the Work and all materials and equipment to be incorporated therein, whether in storage on or off the site, under the care, custody or control of the Contractor or any of his Sub-Contractors;
 - c. other property at the site or adjacent thereto, including trees, shrubs, lawns, walks, pavements, roadways, structures and utilities not designated for removal, relocation or

Bayside Community Center

Bid Number	B161012
Bid Date	March 29, 2016
Bid Time	10:00 A.M.

replacement in the course of construction.

3. Contractor shall not permit any construction technique or activity, which decreases building security or safety. Contractors shall cooperate fully with the Galveston County's authorized Representative's and Owner's requirements regarding security and safety of the building.
4. The Contractor shall give all notices and comply with all applicable laws, ordinances, rules, regulations and lawful orders of any public authority bearing on the safety of persons or property or their protection from damage, injury or loss.
5. The Contractor shall provide, erect, maintain, dismantle and remove, as required by existing conditions and progress of the Work, all reasonable safeguards for safety and protection, including posting danger signs and other warnings against hazards, promulgating safety regulations and notifying the Owners and users of adjacent utilities to the work. He shall protect the Owner's property from injury or loss arising in connection with this Contract. He shall adequately protect adjacent property as provided by law and the Contract Documents. He shall provide and maintain all passageways, guard fences, light and other facilities for protection required by public authority, local conditions, or any of the Contract Documents. At no time remove, alter or render ineffective any barricades, railings or cover on the project without written permission of Galveston County's authorized Representative. Where these safety devices are to be turned over to others, upon completion of the work, the devices shall be repaired or replaced so that they meet the required standards prior to turnover.
6. When the use or storage of explosives or other hazardous materials or equipment is necessary for the execution of the Work, the Contractor shall exercise the utmost care and shall carry on such activities under the supervision of properly qualified personnel. Fuel for cutting and burning torches shall be stored in locations and protected as directed by Galveston County's authorized Representative. No volatile liquids shall be used for cleaning agents or as fuels for motorized equipment or tools within a building except with the express approval of Galveston County's authorized Representative. Bulk storage of volatile liquids shall be outside the building at locations directed by Galveston County's authorized Representative and only so much volatile liquid shall be allowed within the building at any given time.
7. The Contractor shall promptly remedy all damage or loss (other than damage or loss insured under Paragraph 26.B to any property referred to in Clauses 24.B.2.b and 24.B.2.c caused in whole or in part by the Contractor, his Sub-Contractors, or anyone directly or indirectly employed by any of them, or by anyone for whose acts any of them may be liable and for which the Contractor is responsible under Clauses 24.B.2.b and 24.B.2.c except damage or loss attributable to the acts or omissions of the Owner or Architect or Engineer or anyone directly or indirectly employed by either of them or by anyone for whose acts either of them may be liable, and not attributable to the fault or negligence of the Contractor are in addition to his obligations under Article 5 in the Trade Contract.
8. The Contractor shall take all precautions required to prevent fires as a result of his operations. Where flame cutting torches, blow torches, or welding tools are required to be used within an existing building, their use shall be as approved by Galveston County's authorized Representative at the site. When welding tools or torches of any type are in use, the Contractor shall have available, in the immediate vicinity of the work, a fire extinguisher of the CO₂ type. The fire extinguisher shall be provided and maintained by the Contractor.
9. The Contractor shall advise Galveston County's authorized Representative, in writing, of all unusual flammable or toxic materials which the Contractor plans to store and use on site.
10. Shielding or similar precautions will be taken adjacent to welding operations
11. The Contractor shall designate a responsible member of his organization at the site whose duty shall be the prevention of accidents. This person shall be the Contractor's superintendent unless otherwise designated by the Contractor in writing to Galveston County's authorized Representative, and shall attend all project safety meetings scheduled by Galveston County's authorized Representative.

Bayside Community Center

Bid Number B161012
Bid Date March 29, 2016
Bid Time 10:00 A.M.

12. Every employee will be dressed for the work he performs. Minimum dress will consist of long pants, tee shirt, hardhat, safety glasses and work shoes. Shorts, cut-offs, "tank-top" shirts or soft-toed shoes will not be permitted.
13. Each Contractor shall, in a readily visible manner, identify all of his tools, equipment and similar materials, either by paint color or label. The Contractor shall provide his employees with a hard hat bearing his first initial, last name, and his Company name. This information shall be clearly visible at all times.
14. The Contractor shall not load or permit any part of the Work to be loaded so as to endanger its safety.
15. Weather protection shall be supplied by the Contractor and shall include any enclosure, supplemental heating, and furnishing and *any* other features (insulation, etc.) for meeting conditions required by Galveston County's authorized Representative or by the Project Manual relative to the Contractor's work.

25. Emergencies

- A. In an emergency affecting the safety or life of individuals, or of the Work, or of adjoining property, the Contractor, without special instruction or authorization from the Owner or Galveston County's authorized Representative or Architect or Engineer, shall act, at his discretion, to prevent such threatened loss or injury. Also, should he, to prevent threatened loss or injury, be instructed or authorized to act by the Owner or Galveston County's authorized Representative or Architect or Engineer he shall so act, without appeal. Any additional compensation or extension of time claimed by the Contractor on account of any emergency work shall be determined as provided by Article 27 - Changes in Work.

26. Insurance

- A. Contractor shall purchase from and maintain in a company lawfully authorized to do business in the State of Texas and which carry a Best's rating of A-VII or higher such insurance as will protect the Contractor from claims set forth below which may arise out of or result from the Contractor's operations under this Agreement and for which the Contractor may be legally liable.
 1. claims under workers compensation, disability benefit and other similar employee benefit acts which are applicable to the operations to be performed;
 2. claims for damages because of bodily injury, occupational sickness or disease, or death of the Contractor's employees or ;
 3. claims for damages because of bodily injury, sickness or disease, or death of any person other than the Contractor's employees;
 4. claims for damages insured by usual personal injury liability coverage which are sustained (1) by a person as a result of an offense directly or indirectly related to employment of such person by the Contractor, or (2) by any other person;
 5. claims for damages, other than to the Work itself, because of injury to or destruction of tangible property, including loss of use resulting therefrom;
 6. claims for damages because of bodily injury, death or property damage arising out of ownership, maintenance or use of a motor vehicle;
 7. claims involving contractual liability insurance applicable to the Contractor's obligations under
- B. Contractors Liability Insurance
 1. Contractor shall keep in full force and effect, a policy of public liability and property damage insurance issued by a casualty company authorized to do business in the State of Texas, and in standard form approved by the Board of Insurance Commissioners' of the State of Texas, with coverage provision insuring the public from any loss or damage that may arise to any person or property by reason of services rendered by successful Proposer and providing that the amount by reason of services limits of not less than the following sums:
 - a. Workmen's Compensation
 - 1) State Statutory limits
 - b. Comprehensive General Liability (including Premises – Operations; Independent Contractor's Protective; Products and Completed Operations; Broad Form Property Damage
 - 1) Bodily Injury

Bayside Community Center

Bid Number

B161012

Bid Date

March 29, 2016

Bid Time

10:00 A.M.

- i. \$100,000.00 each person, each occurrence
 - ii. \$300,000.00 Aggregate, each occurrence
 - c. Property Damage including loss of use
 - 1) \$100,000.00 Each occurrence
 - d. Products and Completed Operations to be maintained for one (1) year after Final Payment
 - e. Property Damage Liability Insurance will provide X, C or U coverage as applicable
- C. Contractual Liability
 1. Bodily Injury
 - a. \$100,000.00 Each Person
 - b. \$300,000.00 Each occurrence
 2. Property Damage
 - a. \$100,000.00 Each occurrence
- D. Personal injury, with Employment Exclusion deleted:
 - a. \$100,000.00 Each occurrence
- E. Comprehensive Automobile Liability (including owned, non-owned and hired motor vehicles):
 1. Bodily Injury
 - a. \$100,000.00 Each Person
 - b. \$300,000.00 Each occurrence
 2. Property Damage
 - a. \$100,000.00 Each occurrence
- F. Umbrella Liability Coverage:
 1. \$1,000,000.00 to provide excess liability coverages required above.
- G. Professional Liability Coverage:
 2. \$1,000,000.00 to Abatement and Associated work or minimum State law.
- H. Galveston County, Construction Manager, and Architect or Engineer shall be named as "additional insured" on such policies as are specified above and shall be notified of any changes to the policy during the contractual period.
- I. The above requirements do not establish limits of Contractor's liability.
- J. Such insurance is to be provided at the sole cost of Contractor.
- K. All policies of insurance shall waive all rights of subrogation against Galveston County, its officers, employees and agents.
- L. Galveston County reserves the right to require additional insurance should it be deemed necessary.
- M. This insurance required by Subparagraph 26.B-G shall be written for not less than limits of liability listed or required by law, whichever is greater.
- N. The insurance required by Subparagraph 26.B-G shall include premises operations (including explosion, collapse and underground coverage), elevators, independent contractors, products and/or completed operations, and contractual liability insurance (on a "blanket basis" designating all written contracts), all including broad form property damage coverage. Liability insurance may be arranged under Commercial General Liability policies for the full limits required or by a combination of underlying policies for lesser limits with the remaining limits provided by an Excess or Umbrella Liability Policy.
- O. The insurance required by Subparagraph 26.B-G shall include contractual liability insurance applicable to the Contractor's obligations under Article 5 in the Trade Contract
- P. Property Insurance
 1. Unless otherwise provided, the Owner will purchase and maintain property insurance upon the entire Work at the site to the full insurable value thereof. This insurance shall include the interests of the Owner, Galveston County's authorized Representative, the Contractors and Sub-Contractor in the Work and shall insure against the perils of fire and extended coverage, and shall include "all risk" insurance for physical loss or damage. This coverage carries a deductible per occurrence, which will be paid by the Contractor or Sub-Contractor responsible for each loss. This insurance coverage does not cover the Contractor's or Sub-Contractor's tools and equipment.
 2. The Owner will effect and maintain such boiler and machinery insurance as may be necessary and/or required by law. This insurance shall include the interest of the Owner, Galveston County's authorized Representative, the Contractors, and Sub-Contractors in the Work.

Bayside Community Center

Bid Number	B161012
Bid Date	March 29, 2016
Bid Time	10:00 A.M.

3. Any loss insured under Paragraph 26.B-G is to be adjusted with the Owner and made payable to the Owner as trustees for the insured's, as their interests may appear, subject to the requirements of any applicable mortgage clause.
4. The Owner, Galveston County's authorized Representative, the Architect or Engineer, the Contractors, and the Sub-Contractors waive all rights against each other and any other contractor or subcontractor engaged in the Project for damages caused by fire or other perils to the extent covered by insurance provided under Paragraph 30.2, or any other property or consequential loss insurance applicable to the project, equipment used in the Project, or adjacent structures, except such rights as they may have to the proceeds of such insurance. If any policy of insurance requires an endorsement to maintain coverage with such waivers, the owner of such policy will cause the policy to be so endorsed. The Owner will require, by appropriate agreement, written where legally required for validity, similar waivers in favor of the Contractors and Sub-Contractors by any separate contractor and his subcontractors.
5. The Owner shall deposit in a separate account any money received as trustees, and shall distribute it in accordance with such agreement as the parties in interest may reach.
6. The Owner as trustees shall have power to adjust and settle any loss with the insurers.
7. If the Owner finds it necessary to occupy or use a portion or portions of the Work prior to Substantial Completion thereof, such occupancy shall not commence prior to a time mutually agreed to by the Owner and Galveston County's authorized Representative and to which the insurance company or companies providing the property insurance have consented by endorsements to the policy or policies. This insurance shall not be cancelled or lapsed on account of such partial occupancy.

27. Changes in the Work

A. Change Authorization/Contract Amendments

1. Changes in the Work may be accomplished after execution of the contract, and without invalidating the Contract, by Change Order, or order for a minor change in the work, subject to the limitations stated in this Article 27 and elsewhere in the contract Documents. A Change Authorization is a written order to the Contractor signed by Owner, in the form of an Agreement Amendment issued after the execution of the Contract, authorizing a Change in the Work or an adjustment in the Contract Sum and/or the Contract Time. The Contract Sum and the Contract Time may be changed only by Written Amendment. An Amendment signed by the Contractor indicates his agreement therewith, including the adjustment in the Contract Sum and/or the Contract Time. Contractor agrees that the dollar amount and time extensions, as applicable, in each Change Order constitutes full compensation to the Contractor for all costs, expenses and damages to the Contractor, whether direct, consequential or otherwise, in anyway incidental to or arising out of, or resulting, directly or indirectly from the work performed or modified by the Contractor. Amendments not formally rejected within ten (10) days after receipt shall be deemed accepted.
2. If unit prices are stated in the Contract Documents or subsequently agreed upon, and if the quantities originally contemplated are so changed in a proposed Change In The Work that application of the agreed unit prices to the quantities of work proposed will cause substantial inequity to the Owner or the Contractor, the applicable unit prices shall be equitably adjusted.

B. Concealed Conditions

1. Should concealed conditions be encountered in the performance of the Work below the surface of the ground or should concealed or unknown conditions in an existing structure be at variance with the conditions indicated by the Contract Documents, or should unknown physical conditions in an existing structure of an unusual nature, differing materially from those ordinarily encountered and generally recognized as inherent in work of the character provided for in this Contract, be encountered, the Contractor must report the conditions to Galveston County's authorized Representative before the conditions are disturbed. Galveston County's authorized Representative shall thereupon notify the Architect or Engineer.
 - a. Upon such notices, or upon his own observation of such conditions, the Architect or

Bayside Community Center

Bid Number B161012
Bid Date March 29, 2016
Bid Time 10:00 A.M.

Engineer shall promptly make such changes in the Drawings and Project Manual as he finds necessary to conform to the different conditions. Any change in the cost of the work or the time needed for completion resulting from concealed conditions shall be determined in accordance with Article 8 in the Trade Contract provided a notice there of is made within ten (10) days after the first observance of the conditions.

C. Claims for Additional Cost

1. A change in the work may be initiated in one of two ways:
 - a. A "Request for Proposal" Form (RFP) from Galveston County's authorized Representative to the Contractor describing the revision to the work desired. Usually, it is accompanied by revised drawings, sketches or other data.
 - b. Formal notification from the Contractor documenting a "concealed condition" requesting investigation by Galveston County's authorized Representative and Architect or Engineer which causes changes in the Drawings and Project Manual (and a subsequent Request for Proposal on the revised documents).
2. If the Contractor claims that any instructions given to him by Galveston County's authorized Representative, by drawings or otherwise, involve extra work not covered by the Contract, he shall give Galveston County's authorized Representative written notice of the additional cost within ten (10) days after the receipt of such instructions and before proceeding to execute the work, except in emergencies endangering life or property, in which case the Contractor shall proceed in accordance with Article 27. Should it not be clear to the Contractor that a change will involve extra work, written notice given within five (5) days that the change may involve extra work will be considered sufficient notice. If it is later determined that the work involved in such instruction shall be recognized as an extra, the amounts of additional compensation to be paid therefore, should be determined in accordance with Article 8 in the Trade Contract. Failure to respond as noted shall waive the Contractor's claim for additional compensation.
3. Timely submittal (Return) of Requests for Proposal is mandatory. RFP's shall be answered and returned within ten (10) days of receipt. Failing to return RFP's within thirty (30) days may constitute basis for withholding progress payments.
4. Galveston County's authorized Representative will inform the Contractors, and the Contractor will inform Galveston County's authorized Representative when either party recognizes a proposed change (RFP) may affect the progress of the work as scheduled.
5. Any claim for damages of any character, delays for which the Owner is liable under the Contract Documents, extra work or extra compensation of any other nature, shall be waived unless notice thereof is given to Galveston County's authorized Representative, in writing, within 10 days after the occurrence of the event which is relied upon to justify the claim or within such time as the event should have reasonably been discovered by the Contractor, and in any event, before extra cost is incurred.

D. Minor Changes in the Work

1. The Architect or Engineer will have authority to order through Galveston County's authorized Representative minor changes in the Work not involving an adjustment in the Contract Sum or an extension of the Contract Time and not inconsistent with the intent of the Contract Documents. Such changes shall be effected by written order and such changes shall be binding on the Owner, Galveston County's authorized Representative, and the Contractor. The Contractor shall carry out such written orders promptly.

28. Uncovering and Corrections of Work

A. Uncovering of Work

1. If any portion of the Work should be covered contrary to the request of Galveston County's authorized Representative or Architect or Engineer, or to requirements specifically expressed in the Contract Documents, it must, if required in writing by Galveston County's authorized Representative, be uncovered for their observation and replaced, at the Contractor's expense.
2. If any other portion of the Work has been covered which neither Galveston County's authorized Representative nor the Architect or Engineer has specifically requested to observe prior to being

Bayside Community Center

Bid Number B161012
Bid Date March 29, 2016
Bid Time 10:00 A.M.

covered, the Architect or Engineer or Galveston County's authorized Representative may request to see such Work and it shall be uncovered by the Contractor. If such Work be found in accordance with the Contract Documents, the cost of uncovering and replacement shall, by appropriate Change Order, be charged to the Owner or Construction Manager, as the case may be. If such Work were found not in accordance with the Contract Documents, the Contractor shall pay such costs unless it is found that this condition was caused by a separate Contractor employed as provided in Article 15, and in that event, the separate Contractor shall be responsible for the payment of such costs.

B. Correction of Work

1. The Contractor shall promptly correct all Work rejected by the Architect or Engineer or Galveston County's authorized Representative as defective or as failing to conform to the Contract Documents whether observed before or after Substantial Completion and whether or not fabricated, installed complete. The Contractor shall bear all costs of correcting such rejected Work, including compensation for the Architect or Engineer's and/or Galveston County's authorized Representative's additional services made necessary thereby.
2. If, within one year after the Date of Substantial Completion of Work or designated portion thereof, or within one year after acceptance by the Owner of designated equipment or within such longer period of time as may be prescribed by law or by the terms of any applicable special warranty required by the Contract Documents, the Contractor is notified of defective work he shall correct it promptly. This obligation shall survive the termination of the Contract. The Owner or Galveston County's authorized Representative shall give such notice promptly after discovery of the condition.
3. The Contractor shall remove from the site all portions of the Work which are defective or nonconforming and which have not been corrected under Subparagraphs 8.1, 28.B.1 and 28.B.2, unless removal has been waived by the Owner.
4. If the Contractor fails to correct defective or nonconforming Work as provided in Subparagraphs 8.1, 28.B.1 and 28.B.2, the Owner or Galveston County's authorized Representative may correct it in accordance with Article 9 in the Trade Contract.
5. If the Contractor does not proceed with the correction of such defective or nonconforming work within a reasonable time fixed by written notice from Galveston County's authorized Representative, the Owner or Galveston County's authorized Representative may remove it and may store the materials or equipment at the expense of the Contractor. If the Contractor does not pay the cost of such removal and storage within ten days thereafter, the Owner or Galveston County's authorized Representative may upon ten additional days' written notice sell such Work at auction or at private sale and shall account for the net proceeds thereof, after deducting all the costs that should have been borne by the Contractor, including compensation for the Galveston County's authorized Representative's additional services made necessary thereby. If such proceeds of sale do not cover all costs, which the Contractor should have borne, the difference shall be charged to the Contractor and an appropriate Contract Amendment shall be issued. If the payments then or thereafter due the Contractor are not sufficient to cover such amount, the Contractor shall pay the difference to the Owner or Galveston County's authorized Representative.
6. The Contractor shall bear the cost of making good all work of other contractors destroyed or damaged by such removal or correction.
7. Nothing contained in this Article shall be construed to establish a period of limitation with respect to any other obligation, which the Contractor might have under the Contract Documents. The establishment of the time period of one year after the Date of Substantial Completion or such longer period of time as may be prescribed by law or by the terms of any warranty required by the Contract Documents, relates only to the specific obligation of the Contractor to correct the Work, and has no relationship to the time within which his obligation to comply with the Contract Documents may be sought to be enforced, nor to the time within which proceedings may be commenced to establish the Contractor's liability with respect to his obligations other than specifically to correct the Work.

Bayside Community Center

Bid Number B161012
Bid Date March 29, 2016
Bid Time 10:00 A.M.

29. Termination of the Contract

A. Termination by the Contractor

1. If the Work is stopped, under an order of any court or other public authority having jurisdiction, for a period of three (3) months, through no fault of the Contractor or a Sub-Contractor or their agents or employees or any other persons performing any of the Work under a contract with the Contractor, or if Galveston County should fail to pay the Contractor in accordance with Article 3 of the Trade contract, the Contractor may, upon thirty (30) additional days written notice terminate the contract and recover from the Owner payment for all Work executed and for any proven loss sustained upon any materials, equipment, tools, construction equipment and machinery.

B. Termination by the Owner

1. If the Contractor is adjudged a bankrupt, or if he makes a general assignment for the benefit of his creditors, or if a receiver is appointed on account of his insolvency, or if he persistently or repeatedly refuses or fails, except in cases for which extension of time is provided, to supply enough properly skilled workmen or proper materials, or if he fails to make prompt payment to Sub-Contractors or suppliers, or persistently disregards laws, ordinances, rules, regulations or orders of any public authority having jurisdiction, or otherwise is guilty of a substantial violation of a provision of the Contract Documents, then the Owner without prejudice to any right or remedy and after giving the Contractor and his surety, if any, ten days written notice, terminate the Contract and take possession of the site and of all materials, equipment, tools, construction equipment and machinery thereon owned by the Contractor and may finish the work by whatever method he may deem expedient. In such case, the Contractor shall not be entitled to receive any further payment until the Work is finished.
2. If the unpaid balance of the Contract Sum exceeds the costs of finishing the Work, including compensation for the Architect or Engineer or Galveston County's authorized Representative's additional services made necessary thereby, such excess shall be paid to the Contractor. If such costs exceed the unpaid balance, the Contractor shall pay the difference to the Owner.

C. Termination for Convenience

1. The Owner reserves the right, for its convenience, to terminate the Work of the Contractor(s), in whole or in part, at any time by providing written or telegraphic notice to the Contractor stating the extent and effective date of such termination; whereupon such Contractor(s) shall: (i) stop all work and place no further orders or subcontracts for materials, services, equipment or supplies, except as may be necessary to complete portions of the Work not terminated; (iii) terminate work orders, purchase orders and subcontracts outstanding to the extent that they relate to the terminated portion of the Work; (iv) take any action necessary to protect property in Contractor's possession in which the Owner has or may acquire an interest; (v) complete performance of the un-terminated portion of the Work; and (vi) take any other action toward termination of the Work which Galveston County's authorized Representative may direct.
2. In the event that all or a portion of the Work of the Contractor(s) is terminated pursuant to Subparagraph 29.C.1 Contractor(s) shall be entitled to payment of those costs relating to the terminated portion of the Work as hereinafter defined. The Owner shall thereafter pay to the Contractor(s), subject to the limitations herein set forth, the sum of the following costs which represent the respective interest of the Contractor(s) to the terminated portion of the Work:
 - a. Portion of the Contract Sum related to the work completed by the Contractor immediately prior to Notice of Termination.
 - b. Expenses incurred or for which the Contractor is liable as the result of termination by Contractor of respective work orders, purchase orders or subcontracts related to the Notice of Termination including overhead and profit or completed work.
 - c. No payment shall be made for work not actually performed. Deductions will be made by Owner for amounts previously paid to Contractor and for any amounts which may be due Owner, or which Owner may offset or withhold by the terms hereof. The total amount of all payments to Contractor shall not exceed in any event, the proportion of

Bayside Community Center

Bid Number	B161012
Bid Date	March 29, 2016
Bid Time	10:00 A.M.

the total Contract Sum that the Work actually performed (including materials delivered to the project site minus credits for returned goods or cancelled orders) at the date of termination bears to the entire Work to be performed hereunder.

- d. After receipt of a Notice of Termination, Contractor shall submit to Galveston County's authorized Representative its written termination claim in the form and with the certification which the Owner or Galveston County's authorized Representative may require. Such claims shall be submitted promptly, but in no event more than ninety (90) days after the effective date of termination.

30. Temporary Services and Systems

A. General

1. Galveston County's authorized Representative will provide temporary toilets, excluding Contractor's trailer hookup.
2. Galveston County's authorized Representative will provide temporary fire safety equipment for general use. Each Contractor shall provide their own fire extinguishers for their trailers, and for use, as required when cutting and burning are performed.
3. Galveston County's authorized Representative will provide rubbish containers and rubbish disposal service unless noted otherwise in the Proposal Form. The Contractor must not use these containers for the disposal of earth, surplus or slop concrete, hazardous materials, and/or steel stock. Each Contractor must dispose of these elements at his own expense.
4. For further description and location of temporary services and system, refer to the Site Utilization Plan and the following paragraphs. Each Contractor shall be responsible for furnishing, installing or otherwise providing any or all of the following temporary facilities, structures or services as they may be necessary or required for or during, performance of the work of his Contract
 - a) Temporary field office facilities complete, including all furniture, heat, cooling, lighting, telephone, plumbing and toilet fixtures as he may require for his exclusive use. (Site location and number are subject to approval of Galveston County's authorized Representative).
 - b) Temporary storage facilities, sheds or buildings as may be required for the proper protection or storage of materials and/or equipment. (Site location and number are subject to approval of Construction Manager).
 - c) Temporary extension from, and hookup to, all temporary utilities which have been provided to a common point for use by the Contractors during construction.
 - d) Maintenance, cleanup and removal of all temporary facilities provided by the Contractor for his exclusive use.
 - e) Furnishing, erection, maintenance and removal of all temporary hoists and scaffolding as may be required by the Contractor for the performance of the work of his Contract.
 - f) Temporary drainage and dewatering measures including all pumping, drainage, erosion control or other work required to protect the work of the Contractor while in progress.
 - g) All temporary facilities, structures, services or items of work specifically required or defined in the Scope of Work of the Contract (Proposal Package) or otherwise required by the Contract Documents for his work.
 - h) Distribution of drinking water for his construction personnel.
 - i) At the end of the day's work, all work subject to damage by adverse weather conditions shall be covered or otherwise protected as required. Weather protection shall be adequate to permit each Contractor to work on a continuous basis without shutdown due to temperature or weather conditions as far as possible.
 - j) No temporary service shall be removed or disconnected until the new parts have been installed to replace them, properly connected and ready for use. The changing over from temporary to permanent work shall be done expeditiously, and if possible so that no part of the building or premises shall be without adequate service. If this is not possible, the procedure must be planned and submitted to Galveston County's

Bayside Community Center

Bid Number B161012
Bid Date March 29, 2016
Bid Time 10:00 A.M.

authorized Representative for approval.

- B. Temporary Electric System
1. Electric power for use in temporary trailers shall be available to the Contractor from a central location in the trailer area. The Contractor shall furnish any required extensions from this location at his own expense.
 2. Electric service and distribution. The central service will be installed from the Utility Company's service point to the central distribution point on-site. Distribution from this point to the central connection point in the trailer area will be installed including any transformers, main disconnected switch or switches, any metering, supports, protective enclosure and grounding
 - a. Service will terminate in a panel board equipped with circuit breakers. Service characteristics available will be 120/208 volts, three phase, 4 wire web, unless otherwise specified. Total capacity to be shared shall be 400 amps. Use of electricity for basic heating of trailers will not be allowed
 - b. The distribution will be extended to the designated distribution points within the building. These distribution locations will provide:
 1. Panel board for breakers for lighting and hand tool circuits throughout the area served.
 2. Panel board and breakers for twenty (20) 20 amp circuits for connection of bench tools, such as, pipe threaders, etc.
 - c. The distribution will be extended upward to other floors of the building as indicated.
 - d. As the work progresses, structure, and decks are constructed, the lighting/hand tool circuits will be installed throughout the building according to the following criteria
 - e. Temporary lighting shall be installed in all areas and rooms, including all platforms, levels and stairways but excluding crawl spaces, duct and riser shafts. Temporary lighting shall be a minimum of 1/4 watt per square foot. For all areas 3,200 square feet or less, 100-watt lamps spaced approximately at 20 foot centers shall be used. Each room or enclosed area shall have, at least, one lighting and one tool outlet. Where 100 watt lights are used, the outlets shall consist of double weatherproof sockets. One (1) socket shall be used for the 100-watt lamp and the other socket shall be used for portable power tools.
 - f. Any temporary lighting required beyond the foregoing shall be provided by the party requiring the same and the work will be paid for by the Contractor.
 - g. Any extension cords will be provided by the Contractor.
 - h. Connecting and disconnecting Contractor tools and equipment to (and from) the above distribution system will be performed by qualified personnel, ALL grounding as required by the National Electrical Code, OSHA or any and all local codes, including approved ground fault interrupters shall be furnished and installed at the Contractors expense.
 - i. All contractors must share the system provided and average usage is anticipated. Any contractor anticipating fabrication area or operations must coordinate his needs through Galveston County's authorized Representative. If additional distribution is required and available at the control service, it will be provided at the Contractor's expense.
 3. Operations and Maintenance
 - a. The system will be operated during normal work week, defined as five (5) days, including 1/2 hour before regular working hours and 1/2 hour after regular working hours for every trade.
 - b. Maintenance of the electrical service beyond the duration defined above will be at the expense of the Contractor requesting the service. Charges for maintenance of the services will be made from the Operating Contractor to the Contractor and will not involve (nor occur cost to) Galveston County's authorized Representative or Owner.
 4. Relocation to allow construction to proceed and removal when permanent power is available will be coordinated with Galveston County's authorized Representative as part of the maintenance service.

Bayside Community Center

Bid Number B161012
Bid Date March 29, 2016
Bid Time 10:00 A.M.

5. The Electrical Contractor may be requested in a Proposal Package to include part or all of the above described temporary service and distribution and/or maintenance. (Review Scope of Work carefully).
 6. Payment for Electrical Energy
 - a. The Owner will pay for the cost of all energy consumed by all trades during the construction
- C. Temporary heating
1. Construction Heating
 2. Each Contractor shall be responsible for providing his own temporary heat and weather tight enclosures as required for the satisfactory performance of his work and to comply with the construction schedule. Temporary heat systems must be approved by Galveston County's authorized Representative.
 3. Temporary Use of Building System
 4. It is not anticipated that the permanent building system will be utilized to provide "temporary heat" during the major portion of construction operations
 5. It is anticipated that activation, testing and balancing of the building heating/cooling system will be critical to the completion and acceptance of the project and therefore actuation, of the permanent system will be scheduled for the earliest possible time.
 6. Within these parameters the Contractor must provide any supplemental heat required to perform his work.
 7. In the proposal form, the Contractor may be requested to indicate an amount included for "supplemental heat" (not construction heating) as Galveston County's authorized Representative may request proposals for providing an interim heating system from the Mechanical Contractor. (Review Scope of Work Carefully).
- D. Temporary Water
1. Potable water shall be available to the Contractor at a central location. Extensions of the water supply for Contractor's exclusive use shall be the responsibility of the Contractor.
 2. Temporary water distribution as indicated on Site Utilization will be provided for the use of all Contractors and to provide a temporary fire protection system.
 3. The temporary fire protection system shall be installed using the permanent standpipes and risers, and shall be installed as rapidly as construction permits.
 4. Temporary fire standpipe connections, including pipe fittings, and valves shall be provided at the location of each permanent hose rack or station as shown on the contract drawings.
 5. At each temporary riser connection shall be provided a temporary hose rack, 100 feet of 1-1/2" UL approved fire hose system with brass couplings and a 1-1/2" nozzle. The system shall also provide 2-1/2" valved, capped connection at each location together with 1-1/2" valved connection with a pair of hose bibs. Hose adapters on the discharge side of the 2-1/2" valve shall be compatible with hose fittings used by the local fire department.
 6. All Contractors are responsible for providing their own hoses to bring water from the hose rack location to their work **areas**. Only heavy-duty 3/4" hose in good conditions will be permitted in use in the interior of the building. The discharge end of each hose shall be equipped with a means of positive shut off. The use of hoses, which leak at connections or elsewhere throughout their length, will not be permitted. All hoses shall be disconnected from hose bibs when not in use and before the end of each work day.
 7. When no longer required, as determined by Galveston County's authorized Representative, the temporary systems shall be dismantled and removed.
 8. Water will be provided to all Contractors without cost, and any billings therefore will be paid by Galveston County's authorized Representative.
 9. The Plumbing Contractor may be requested in the Proposal Package "Scope of Work" to include furnishing installing and dismantling and removing the temporary water/temporary fire protection system described above.
 10. In such event the temporary equipment and materials so removed shall become the property of the Plumbing Contractor. (Review Scope of Work Carefully)

Bayside Community Center

Bid Number B161012
Bid Date March 29, 2016
Bid Time 10:00 A.M.

- E. Housekeeping - Cleaning and Rubbish Removal
1. Each Contractor shall be responsible for daily and final cleanup and continuous removal of all rubbish and debris from the building and site. Galveston County's authorized Representative shall provide, erect, locate, and maintain a rubbish chute and/or rubbish collection dumpster system for use of all trades. Each Contractor shall be responsible to deposit his daily rubbish into these chutes or dumpster locations as designated and provided by Galveston County's authorized Representative. Failure of a Contractor to do so will require that this be done by Galveston County's authorized Representative after proper notice to the Contractor and labor for doing so shall be charged to the responsible Contractor
 2. The jobsite shall be maintained in a neat orderly condition and kept free from accumulations of waste materials and rubbish during the entire construction period. Contractor will remove all crates, cartons and other flammable waste materials or trash from the work areas at the end of each working day.
 3. Elevator shafts, electrical closets, pipe and duct shafts, chases, furred spaces and similar spaces which are generally unfinished, shall be cleaned and left free from rubbish, loose plaster, mortar drippings, extraneous construction materials, dirt and dust before substantial completion review.
 4. Each Contractor shall be responsible for cleaning all surfaces as necessary to make them free of spatters or other deposits of paint, plaster, mortar, concrete, adhesives, roofing, dirt, soil, oil, or any other material foreign to the surface involved. Galveston County's authorized Representative shall back-charge to the guilty party the cost of cleaning which is required by accidental soiling or damage by another Contractor.
 5. Each Contractor is responsible to share the task of litter cleanup (e.g., coffee cups, lunch wrappers, etc.).
 6. However, to insure proper cleanup, notwithstanding the Contractor's obligations to cleanup any debris resulting from his own operations, and following proper notices Galveston County's authorized Representative will undertake the cleanup and disposal of litter and other debris whose source is unidentifiable. The cost of this special cleanup detail will be assessed weekly against all Contractors on a per capita basis and invoiced monthly. If any cleanup invoice is not paid within thirty (30) days, it will be back-charged against the respective Contractor's monthly payment application.
 7. The Contractor shall be responsible to maintain his own trailer, storage and work areas in a sanitary condition to minimize the hazard of attracting vermin and breeding mosquitoes. If the Contractor fails to comply, Galveston County's authorized Representative may do so, and the cost thereof shall be charged to the Contractor. Rodent extermination materials shall be those approved by the local health department or other agency having jurisdiction.
 8. Use only cleaning materials and methods recommended by manufacturer of surface to be cleaned. Use cleaning materials only on surfaces recommended by cleaning material manufacturer. Each Contractor shall be responsible for assuring that affected employees are provided with, and required to use, all needed personal protective devices in connection with cleaning.
 9. At completion of work, each Contractor shall remove tools, equipment, machinery, and surplus materials from the project site and perform whatever additional cleaning is specified in the Proposal Form.
- F. Vehicle cleaning - Trucking
1. Galveston County's authorized Representative will designate the wash-down area to be utilized by the Contractors. The "wheel wash station" will be equipped with a hose connection and drainage area. The Contractor shall provide manpower, hose and other supplemental scrapers, brushes, etc., which may be required to satisfactorily clean his vehicles leaving the site. The construction of this temporary facility may be included in the "Scope of Work" of the excavation or site Preparation Proposal Package, Review scope of work carefully.
 2. All vehicles shall be cleaned of all mud and debris before leaving the site. Each Contractor shall be responsible for providing whatever personnel may be required to perform the required vehicle cleaning throughout the progress of his work. The wash-down area shall not be used for cleaning

Bayside Community Center

Bid Number B161012
Bid Date March 29, 2016
Bid Time 10:00 A.M.

- out of concrete mix trucks.
3. Cleaning of concrete equipment shall be performed at locations designated by Galveston County's authorized Representative. Cleaning shall be conducted in such a manner as to prevent spillage of fluid or concrete to the ground or penetration of existing ground soil. The responsible Contractor shall remove from the site all residues accumulated from the cleaning operations of concrete equipment..
 4. All trucks leaving the site with earthen materials or loose debris shall be loaded in a manner that will prevent dropping of materials on streets, and when necessary, shall have suitable coverings fastened over the load before they enter surrounding paved streets. Trucks bringing earthen materials over paved streets to the site shall be similarly loaded and covered. The Contractor shall conform to all local regulations regarding load limits and be responsible for any costs due to failure to comply with the above.
- G. Site Security, Personnel and Property Protection
1. Contractor shall maintain the security of the worksite and shall restrict access to the site to the following:
 - a. its employees;
 - b. employees of subcontractors;
 - c. representatives of manufacturers whose goods are utilized in the work and are called to the site by either the Contractor or the Program Administrator; and
 - d. agents and/or employees of the County.
 2. Contractor shall provide adequate protection to persons on the worksite, adjacent properties, and utilities as is necessary to keep each free of damage or injury. Contractor shall furnish all barricades, warning lights and other safety devices necessary for the safety and protection of the public and shall remove them upon completion of the work performed on those premises under the terms of this Contract.
 3. Contractor will have complete control over the work site and shall be fully responsible for any loss of or damage to any County property from any cause and will reimburse County in the event of any loss or damage to County's property from any cause.
 4. Contractor shall take proper means to protect adjacent or adjoining properties which might be injured or seriously affected by construction undertaken under this Agreement from any damage or injury by reason of said process of construction. Contractor shall be liable for any and all claims for such damage on account of its failure to fully protect all adjoining properties.
 5. At no time remove, alter or render ineffective any barricades, railings or cover on the project without written permission of Galveston County's authorized Representative. Where these safety devices are to be turned over to others, upon completion of the work, the devices shall be repaired or replaced so that they meet the required standards prior to turnover.
 6. The Contractor shall provide and maintain proper warnings and detour signs at all pedestrian and vehicular closures, intersections, and along detours, directing traffic around closed portions of roadways. The Contractor shall, at his own expense, wherever necessary or required, provide and maintain fences, temporary roadways, temporary cross signs, watchmen, warning lights and take such other precautions as may be necessary to protect life and property, and shall be responsible for all damages occasioned in any way by his act or neglect. All barricades and obstructions shall be illuminated at night, and all lights shall be kept on from one-half hour before sunset, until one-half hour after sunrise.
 7. The Contractor shall provide such openings, channels, chases, flues, etc., if any, and do such cutting, patching, finishing, etc., if any, required by the Contract Documents.
 8. Unless otherwise specified, the Contractor shall furnish and install all sleeves, inserts, hangers, etc., required for the execution of his work.
 9. When performing any cutting, removal, creating opening or holes, etc., the Contractor, by use of barricades, flagmen, or other means, shall provide protective measures to assure that other workmen or the public are not exposed to potential injury by the operation being conducted.
 10. The Contractor shall be responsible for handling and transporting (including lifting) his material and equipment to the location of need in a timely manner.

Bayside Community Center

Bid Number B161012
Bid Date March 29, 2016
Bid Time 10:00 A.M.

11. Any vertical lifting device, whether stationary material hoist, mobile crane or other means, a Contractor plans to use will be implemented only after prior coordination and approval of Galveston County's authorized Representative.

31. Order of Precedence

- A. In the event of any conflict or discrepancy in the provisions of the contract documents, the documents shall be interpreted on the basis of the following order or priority:
 1. Agreement between Owner and Contractor
 2. Proposal Form
 3. Addenda, with later date having greater priority
 4. General Conditions
 5. Project Manual
 6. Drawings, large scale details and/or schedules
 7. Drawings, small scale

32. WAGE RATES

This Contract is a Public Works Contract governed by V.T.C.A., Government Code, Chapter 2258. That Act requires Contractor to pay workers not less than the general prevailing rate of per diem wages for work of a similar character in the locality in which the work is performed and not less than the general prevailing rate of per diem wages for legal holiday and overtime work.

Prevailing wage rates determined by the United States Department of Labor in accordance with the Davis-Bacon Act (40 U.S.C. Section 276a et seq) are used in this Contract and are incorporated and made a part hereof.

In the event other crafts or types of workers are required than are listed therein, such workers shall be paid at a rate not less than the prevailing rate for similar workers in the Galveston County area.

Contractor acknowledges that:

- A. Pursuant to V.T.C.A., Government Code §2258.022, a violation of the obligation to pay workers the prevailing wages shall result in Contractor paying the County the amount of \$60.00 for each worker employed for each calendar day or part of the day that the worker is paid less than the wage rates stipulated in the Contract; and
- B. Contractors and Subcontractors shall be required to keep a record showing the name and occupation of each worker employed by Contractor or Subcontractor in the construction of the work called for in the contract and the actual per diem wages paid to each worker.
- C. **The record shall be submitted weekly on Labor Department forms to the Galveston County Wage Compliance Officer.**

Contractor represents it has read this law and the penalties provided prior to entering into this agreement.

- D. Wage Rates in force for Galveston County are included in Section 01012 Wage Scale.

33. Force Majeure

If by reason of force Majeure either Party shall be rendered unable, wholly or in part, to carry out its responsibilities under this contract by any occurrence by reason of force Majeure, then the Party unable to carry out its responsibility shall give the other Party notice and full particulars of such force Majeure in writing within a reasonable time after the occurrence of the event, and such notice shall suspend the Party's responsibility for the continuance of the forced Majeure claimed, but for no longer period.

Force Majeure means acts of God, floods, hurricanes, tropical storms, tornadoes, earthquakes, or other natural disasters, acts of a public enemy, acts of terrorism, sovereign conduct, riots, civil commotion, strikes or lockouts, and other causes that are not occasioned by either Party's conduct which by the exercise of due diligence the Party is unable to overcome and which substantially interferes with operations.

34. Salvage

Any materials, equipment and fixtures specifically ordered to be salvaged under these specifications shall remain the

Bayside Community Center

Bid Number	B161012
Bid Date	March 29, 2016
Bid Time	10:00 A.M.

property of County and will be delivered to the site designated by Galveston County's authorized Representative. All other items shall be disposed of by Contractor in compliance with all applicable laws and regulations.

35. Open Records

Contractor acknowledges that County is a governmental entity and this Agreement is an open record under the Open Records Act and will be discussed and voted upon in a public meeting.

36. Performance and Payment Bond(s)

V.T.C.A., Government Code Chapter 2253, requires a Performance Bond (for contracts in the excess of \$100,000) and a Payment Bond (for contracts in excess of \$25,000), to be provided by the Contractor. Each bond required shall be equal to the total contract price and shall be issued by a satisfactory surety company. The bond(s) will remain in full force and effect until final completion and acceptance of the work.

The bond(s) are to be made payable to the County of Galveston. They shall be written on forms provided by the surety for public works projects in Texas. A surety licensed to do business in the state of Texas must execute the bond.

Proposers should familiarize themselves with the entire provisions of V.T.C.A., Chapter 2253 and the penalties provided for its violation before submitting their Proposal.

**End of
General Terms and Conditions of the Contract**

SECTION 01010 - SUMMARY OF THE WORK

CONDITIONS OF THE CONTRACT AND DIVISION 1, as indexed, apply to this Section

PART 1 - GENERAL

1.01 SECTION INCLUDES

A. A brief description of the project:

The Work includes the construction of a single story building near 10th Street and Avenue E in Bacliff, Texas. The Work includes related building systems and site paving.

B. Work by Owner: None anticipated other than tele/data.

C. Contractor use of site and premises - there are no limitations on the contractor's use of the site.

END OF SECTION

SECTION 01012 - WAGE SCALE

CONDITIONS OF THE CONTRACT AND DIVISION 1, as indexed, apply to this Section.

1.1 APPLICABILITY

- A. The Contract is a Public Work and is governed by V.T.C.A., Government Code, Chapter 2258. Proposers are advised that in accordance with the Act's terms, a Contractor is required to pay workers not less than the general prevailing rate of per diem wages for work of similar character in the locality in which the work is performed and not less than the general prevailing rate of per diem wages for legal holiday and overtime work. A copy of the prevailing wages to be paid in the performance of the work called for herein is attached hereto and by reference, made a part hereof. The County's determination of the General Prevailing Rate of per diem wages is final.

Prevailing wage rates determined by the United States Department of Labor in accordance with the Davis-Bacon Act (40 U.S.C. Section 276a et seq) are used in this Contract and are incorporated and made a part hereof.

In the event other crafts or types of workers are required than are listed therein, such workers shall be paid at a rate not less than the prevailing rate for similar workers in the Galveston County area.

- B. Pursuant to V.T.C.A., Government Code 2258.022, a violation of the obligation to pay workers the prevailing wages shall result in the Contractor paying the County the amount of \$60.00 for each worker employed for each calendar day or part of the day that the worker is paid less than the wage rates stipulated in the Contract; and.
- C. Trade Contractors and Subcontractors shall be required to keep a record showing the name and occupation of each worker employed by the Contractor or Subcontractor in the construction of the work called for in the Contract and the actual per diem wages paid to each worker. The record shall be open at all reasonable hours to inspection by the officers and agents of the County.
- D. Contractors and Subcontractors shall submit Certified Payroll Reports on U. S. Department of Labor forms (WH-327 or latest edition). The reports must be submitted weekly **to the Galveston County Wage Compliance Officer** by the Trade Contractor and Subcontractors. Trade Contractor's request for Payments will not be processed or checks issued until all reports are current.
- E. Davis-Bacon Wage Determinations - Texas - Galveston County

END OF GENERAL DECISION

SECTION 01020
ALLOWANCES

CONDITIONS OF THE CONTRACT AND DIVISION 1, as indexed, apply to this Section.

PART 1 - GENERAL

A. SCOPE

1. The Contractor shall include in his proposal the allowances stated in this and following Sections of the Project Manual. Allowance may pertain to purchase and delivery only, or to purchase, delivery, and installation, or to services only, or to contingency fund.
2. **All of the Contractor's overhead and profit (includes bond, insurance, etc) shall be included in the base proposal for listed allowance items whether such sums are used in the completion of the project or not. (example - if the allowance price is \$1,000.00 and OH&P as determined by the Contractor is 14%, the 14% (\$140.00) would be included in the base price and a full \$1,000.00 in the allowance fund. If the \$1,000.00 is not spent the \$140.00 remains part of the Contractor's remuneration.)**
3. If the allowance is stated for purchase and delivery only, all of the Contractor's handling costs on site and other expenses contemplated for the allowance material and equipment shall be included in the allowance.
4. If the allowance is stated for purchase, delivery, and installation, all of the Contractor's handling costs on site and other expenses contemplated for the allowance material and equipment shall be included in the allowance.
5. If the allowance is stated for services only, all of the Contractor's handling costs on site and other expenses contemplated for the services shall be included in the allowance.
6. If the allowance is stated for contingency, all of the handling costs on site and other expenses contemplated for the allowance material and equipment shall be included in the allowance.
7. The Contractor shall purchase the allowance materials and equipment as directed by the Architect in writing. If the actual cost of the required work is more or less than all the allowance estimates, the Contract Sum will be adjusted accordingly by Change Order at the conclusion of the project.
8. The Architect cannot certify applications for payment of any allowance item unless a fully executed Allowance Authorization is on file with the Owner, Architect, and Contractor.

PART 2 – ALLOWANCES

B. ITEMS

1. Tele/Data Allowance:

Contractor shall include in the Base Proposal the sum listed. Contractor shall proceed with the work in question only after receiving written directions executed by the Owner and the Architect. Owner will not be obligated to pay the cost of any work performed without prior written authorization.

Sum of Tele/Data Allowance \$35,000

2. Contingency Allowance:

Contractor shall include in the Base Proposal the sum listed as a contingency to cover the cost of items not shown on the Contract Documents. Contractor shall proceed with the work in question only after receiving written directions executed by the Owner and the Architect. Owner will not be obligated to pay the cost of any work performed without prior written authorization.

Sum of Contingency Allowance..... 5% of the Base Proposal Sum

3. Testing Allowance:

Contractor shall include in the Base Proposal the sum listed to cover the cost of testing during construction. Contractor shall proceed with the testing work only after receiving written directions executed by the Owner and the Architect. Owner will not be obligated to pay the cost of any work performed without prior written authorization.

Sum of Testing Allowance \$25,000

4. Building Pad Allowance:

Contractor shall include in the Base Proposal the sum listed to cover the cost of the building pad. The soils investigation is not complete at bid time therefore the specification of the building pad is not known at this time. This allowance assumes there will be at least 18 inches of existing soil removed and 3 foot of select fill placed to create the pad. Contractor shall proceed with the work in question only after receiving written directions executed by the Owner and the Architect. Owner will not be obligated to pay the cost of any work performed without prior written authorization.

Sum of Building Pad Allowance..... \$40,000

END OF SECTION

SECTION 01025 - SCHEDULE OF VALUES

CONDITIONS OF THE CONTRACT AND DIVISION 1, as indexed, apply to this Section.

PART 1 – GENERAL

1.1 SCOPE

Provide a detailed breakdown of the agreed Contract Sum showing values allocated to each of the various parts of the work, as specified herein and in other provisions of the Contract Documents. The schedule of values is to be prepared in conformance with this section in order to assist the Architect with timely processing of all Application for Payments.

Related Work: Documents affecting work of this section include, but are not necessarily limited to, General Conditions and Sections in Division 1 of these Specifications.

1.2 SUBMITTALS

1. Prior to the first Application for Payment, submit a proposed schedule of values to the Architect, as outlined below:
 1. Meet with the Architect and determine additional data, if any, required to be submitted.
 2. Secure the Architect's approval of the schedule of values prior to submitting the first Application for Payment. This will allow the Architect to certify the Application for Payment in the timeliest manner.

1.3 SCHEDULE OF VALUES

The Schedule of Values shall be broken down into item costs for each specification section as labor and materials as a minimum.

A. Schedule of Values - Items in addition to Specification sections.

- Mobilization
- Submittals and shop drawings
- Temporary Facilities
- Clean Up
- Building Permit
- Bonds, Insurance
- General Contractors Fee
- Misc. Mechanical Accessories
- Demolition
- Rough-In Labor (Electrical, Plumbing, Mechanical)
- Rough-In Material (Electrical, Plumbing, Mechanical)
- Finish Labor (Electrical, Plumbing, Mechanical)
- Finish Material (Electrical, Plumbing, Mechanical)
- Allowances (each listed separately)
- Project Close-out Documents and O&M Manuals

B. The Schedule of Values must be submitted on AIA Document G703

END OF SECTION

SECTION 01045 - CUTTING AND PATCHING

CONDITIONS OF THE CONTRACT AND DIVISION 1, as indexed, apply to this Section.

PART 1 - GENERAL

1.1 SCOPE

- A. Furnish all labor, materials, equipment and services necessary or incidental to completion of "Cutting and patching" includes cutting into existing construction to provide for the installation or performance of other work and subsequent fitting, and patching required to restore surfaces to their original condition.
1. Cutting and patching is performed for coordination of the work, to uncover work for access or inspection, to obtain samples for testing, to permit alterations to be performed, to remove and replace work not conforming to Contract requirements, or for other similar purposes.
 2. Cutting and patching performed during the manufacture of products, or during the initial fabrication, erection, or installation processes is not considered to be "cutting and patching" under this definition. Drilling of holes to install fasteners and similar operations is also not considered to be cutting and patching.

1.2 SUBMITTALS

- A. Submit written request in advance of cutting or alteration which affects:
1. Structural integrity of any element of the project
 2. Integrity of weather-exposed or moisture-resistant element
 3. Efficiency, maintenance, or safety of any operational element
 4. Visual qualities of sight-exposed elements
 5. Work of Owner or separate contractor
 6. Any work in or around any known or potential area in which asbestos or lead based products exist.
- B. Procedural Proposal for Cutting and Patching: Where prior consent for cutting and patching is required, submit proposed procedures for this work well in advance of the time work will be performed, and request consent to proceed. Include the following information, as applicable, in the submittal:
1. Describe the nature of the work and how it is to be performed, indicating why cutting and patching cannot be avoided. Describe anticipated results of the work in terms of changes to and effects upon existing work, including structural, operational and visual changes, as well as other significant elements.
 2. List products to be used and firms that will perform work.
 3. Give dates when work is expected to be performed.
 4. List utilities that will be disturbed or otherwise be affected by work, including those that will be relocated and those that will be temporarily out of service. Indicate how long utility services will be disrupted.
 5. Where cutting and patching of structural work involves the additional reinforcement, submit details and engineering calculations to show how that reinforcement is integrated with the original structure to satisfy requirements.
 6. Consent by the Architect to proceed with cutting and patching work does not waive the Architect's right to later require complete removal and replacement of work found to be cut and patched in an unsatisfactory manner.

1.4 QUALITY ASSURANCE

- A. Requirements for Structural Work: Do not cut and/or patch structural work without the written direction of the structural engineer.

- B. Operational and Safety Limitations: Do not cut and patch operational elements or safety related components in a manner that would result in a reduction of their capacity, to perform in the manner intended, including energy performances, or that would result in increased maintenance, or decreased operational life, or decreasing safety. Before cutting and patching the following elements of work, and similar work elements where directed, obtain the Architect's consent to proceed with cutting and patching.
1. Shoring, bracing, and sheeting
 2. Primary operational systems and equipment
 3. Water/moisture vapor/air/smoke barriers, membranes and flashings
 4. Noise and vibration control elements and systems
 5. Control, communication, conveying, and electrical wiring systems
- C. Visual Requirements: Do not cut and patch work exposed on the building's exterior or in its occupied spaces, in a manner that would, in the Architect's opinion, result in lessening the building's aesthetic qualities. Do not cut and patch work in a manner that would result in substantial visual evidence of cut and patch work. Remove and replace work judged by the Architect to be cut or patched in a visually unsatisfactory manner. If possible, retain the original installer or fabricator, or another recognized, experienced and specialized firm to cut and patch the following categories of exposed work:
1. Architectural concrete finishes
 2. Brick and concrete unit masonry
 3. Ornamental metal
 4. Roofing
 5. Preformed metal panels
 6. Window system
 7. Gypsum or cement plaster
 8. Acoustical ceilings
 9. Carpeting
 10. Wall covering
 11. HVAC enclosure, cabinets or covers

1.5 PAYMENT FOR COSTS

- A. Cost for work necessary to accommodate installation of new work shall be borne by the Contractor or subcontractor responsible for installing new work.
- B. Costs caused by ill-timed or defective work, or work not conforming to contract documents, including costs for additional services of the Architect and other Design Consultants shall be borne by the party responsible in the judgment of Architect, for ill-timed, rejected or non-conforming work.
- C. Costs for work performed on instruction of Owner, other than the correction of defective or non-conforming work shall be responsibility of the Owner, who shall issue an appropriate Change Order for the increase in costs.

PART 2 - PRODUCTS

2.1 MATERIALS

- A. General: Except as otherwise indicated, or as directed by the Architect, use materials for cutting and patching that are identical to existing materials. If identical materials are not available or cannot be used, use materials that match existing adjacent surfaces to the fullest extent possible, with regard to visual effect. Use materials for cutting and patching that will result in equal-or-better performance characteristics.

- B. For any change in material, submit a request for substitution under the provisions of the General Conditions.

PART 3 - EXECUTION

3.1 GENERAL

- A. Execute cutting, fitting, and patching to complete work, and to:
 - 1. Fit several parts together which will integrate with other work.
 - 2. Uncover work to install ill-timed work.
 - 3. Remove and replace defective and non-conforming work.
 - 4. Remove samples of installed work for testing.
 - 5. Provide openings in elements of work for penetrations of mechanical and electrical work.
 - 6. Fill and refinish existing holes and damaged areas.

3.2 INSPECTION

- A. Before cutting, examine the surface to be cut and patched and the conditions under which the work is to be performed. If unsafe or otherwise unsatisfactory conditions are encountered, take corrective action before proceeding with the work.

3.3 PREPARATION

- A. To prevent failure, provide temporary support of work to be cut.
- B. Protect other work during cutting and patching to prevent damage. Provide protection from adverse weather conditions for that part of the project that may be exposed during cutting and patching operations.
- C. Take precautions not to cut existing pipe, conduit or duct serving the building, but scheduled to be relocated until provisions have been made to bypass them.

3.4 PERFORMANCE

- A. Employ skilled workmen to perform cutting and patching work. Except as otherwise indicated or as approved by the Architect, proceed with cutting and patching at the earliest feasible time and complete work without delay.
- B. Cut the work using methods that are least likely to damage work to be retained or adjoining work. Where possible, review the proposed procedures with the original installer; comply with original installer's recommendations.
 - 1. In general, where cutting is required, use hand or small power tools designed for sawing or grinding, not hammering and chipping. Cut through concrete and masonry using a cutting machine such as a carborundum saw or core drill to ensure a neat hole. To avoid marring existing finished surfaces, cut or drill from the exposed or finished side into concealed surfaces. Temporarily cover the opening when not in use.
 - 2. Comply with requirements of applicable sections of Division 2 when cutting and patching, excavating and backfilling.
 - 3. Bypass utility services such as pipe and conduit, before cutting, where such utility services are shown or required to be removed, relocated or abandoned. Cut-off conduit and pipe in walls or partitions to be removed. After bypassing and cutting, cap, valve or plug, and seal tight the remaining portion of pipe and conduit to prevent entrance of moisture or other foreign matter.

- C. Patching: Patch with seams that are durable and as visible as possible. Comply with specified tolerances for the work.
 - 1. Where feasible, inspect and test patched areas to demonstrate integrity of work.
 - 2. Restore exposed finishes of patched areas, and where necessary, extend finish restoration into retained adjoining work in a manner that will eliminate evidence of patching and refinishing.
 - 3. Where removal of walls or partitions extend one finished area into another finished area, patch and repair floor and wall surfaces in the new space to provide an even surface of uniform color and appearance. If necessary to achieve uniform color and appearance, remove the existing floor and wall coverings and replace with new materials.
 - a. Where a patch occurs in a smooth painted surface, extend final paint coat over the entire unbroken surface containing the patch, after the patched area has received prime and base coat.
 - 4. Patch, repair or rehang existing ceilings as necessary to provide an even plane surface of uniform appearance.
- D. Fit work airtight to pipes, sleeves, ducts, conduit, and other penetrations through surfaces.
- E. At penetrations of fire-rated wall, ceiling, or floor construction, completely seal voids with fire-rated material, full thickness of the construction element.
- F. Refinish surfaces to match adjacent finishes. For continuous surfaces, refinish to nearest intersection; for an assembly, refinish entire unit.

3.5 CLEANING

- A. Thoroughly clean areas and spaces where work is performed or used as access to work. Completely remove paint, mortar, oils, putty and items of similar nature. Thoroughly clean piping, conduit and similar features before painting or other finish is applied. Restore damaged pipe covering to its original condition.

END OF SECTION

SECTION 01200 - PROJECT MEETINGS

CONDITIONS OF THE CONTRACT AND DIVISION 1, as indexed, apply to this Section.

PART 1 - GENERAL

1.1 SCOPE

- A. Contractor is required to participate in a series of regular project meetings. These meetings are scheduled by the Construction Manager for the benefit of the Owner and the project.
- B. These meetings include pre-construction conferences, progress meetings, pre-installation conferences, and close-out meetings.

1.2 PRECONSTRUCTION CONFERENCE

- A. Construction Manager will administer site mobilization conference at project site for clarification of Owner and Contractor responsibilities, in use of site and for review of administration procedures.

1.3 PROGRESS MEETINGS

- A. Construction Manager shall schedule and administer all project meetings after mobilization conference throughout progress of the work at weekly intervals, plus any special called meetings, and all pre-installation conferences. Contractor is required to participate in this regular meeting.
- B. Construction Manager shall make physical arrangements for meetings, preside at meetings, record minutes, and distribute copies of minutes within two days to Owner, Architect, participants, and those affected by decisions made at meetings. Contractor is required to participate in this regular meeting.
- C. Required Attendance: Job Superintendent, Project Coordinator, Owner, and Architect as appropriate to agenda topics for each meeting.
- D. Suggested Agenda: Review of work progress, status of progress schedule and adjustments thereto, delivery schedules, submittals, maintenance of quality standards, pending changes and substitutions, and other items affecting progress of the work.

1.5 INSTALLATION CONFERENCES

- A. When required in individual Specification section, Contractor shall convene installation conferences prior to commencing work of the section.
- B. Require attendance of entities directly affecting, or affected by, work of the section.
- C. Review conditions of installation, preparation and installation procedures, and coordinate with related work.

END OF SECTION

SECTION 01300 - SUBMITTALS

CONDITIONS OF THE CONTRACT AND DIVISION 1, as indexed, apply to this Section.

PART 1 - GENERAL

1.1 SCOPE

- A. Contractor is required to provide shop drawings, submittals, or manufacturer's data to allow the Architect to review them. The Contractor may also submit request for information (RFI). All submittals will be submitted to the Construction Manager.
- B. Each project manual section has submittal requirements listed and the time required for submittal.
- C. Contractor is required to list submittals as a separate item on their Schedule of Values and Application for Payment.
- D. The Architect cannot certify payment to the Contractor for submittals if the submittal review process is not complete in the time frame listed in the project manual or a time frame mutually agreed by the Architect, and Owner.

1.2 PROCEDURES

- A. Contractor creates shop drawings, product data, or samples as required by specific sections of the specifications. The Contractor is responsible for confirming and correcting all quantities and dimensions, selecting fabrication processes and techniques of construction, coordinating the work with that of all trades, and performing all work in a safe and satisfactory manner.
- B. Apply Contractor's stamp, signed, to each item submitted, certifying that review and verification of products, field dimensions, adjacent construction work and coordination of information is in accordance with the requirements of the work and Contract Documents.
- C. Trade Contractor transmits each item to the Construction Manager agent with approved form identifying project, contractor, subcontractor, major supplier; identify pertinent drawing sheet and detail number and specification section number, as appropriate. Identify any deviations from Contract Documents. No deviations will be allowed without prior approval through the substitution process.
- D. The CMA will not review submittals that have not been thoroughly reviewed by the Trade Contractor. If the documents have obvious errors that have not been noted by those reviews the documents will be returned to the Trade Contractor with a request to revise and resubmit from the CMA.
- E. Within 2 weeks of receipt of submittal the CMA will review the submittal for compliance with contract documents and transmit them to the Architect for review.
- F. The Architect will not review submittals that have not been thoroughly reviewed by the CMA and Trade Contractor. If the documents have obvious errors that have not been noted by those reviews the documents will be returned to the CMA with a request to revise and resubmit from the Architect. There will be no partial payments considered for submittals in the review process.
- G. Within 2 weeks of receipt of submittal the Architect and/or Engineer will review the submittal for compliance with contract documents and notify the CMA that the submittal is ready to be picked up.
- H. The CMA will notify the Trade Contractor that the review has been completed and the submittal may be picked up.

- I. The CMA will retain 1 copy of the submittals on site. The Architect will retain 2 file copies of the submittal. The Engineers will retain 1 copy of any submittals that they are required to review.
- J. One copy of the submittals retained by the Architect will be delivered to the Owner at the conclusion of the project.
- K. Contractor will revise and resubmit submittals requested to be revised and resubmitted. He will identify all changes made since the previous submittal. The process will then start over. The Architect will not certify applications for payment of submittals that are in the review process.
- L. The CMA and Architect are not obligated to review submittals that are requested to be revised and resubmitted a second time and may request additional funding from the Owner to do so. The Architect and CMA may request that the Owner claim the expense of repeated re-submittals to the Architect and CMA from the Trade Contractor for submittals resubmitted more than once.
- M. Note that most submittals are required within a short period of time of signing the contract. Refer to the specification Section to determine the exact time.

1.3 SHOP DRAWINGS AND PRODUCT DATA

- A. Provide 4 copies to be retained for the CMA, Architect, and Owner's files and any number required for the Contractor to complete his work.
- B. Manufacturer's Instructions:
When work is specified to comply with manufacturer's printed instructions, obtain and distribute copies of such instructions to parties involved in the installation, at least two weeks prior to start of such work.
- C. All dimensions indicated on the drawings are based on the specific models and manufacturers of products, equipment, fixtures and miscellaneous items specified. If the Contractor uses an approved product by another listed manufacturer which is different than the specific model and manufacturer listed in these specifications, then the Contractor shall be solely responsible for the coordination of any dimensional changes required, including structural, relocation of walls, equipment, fixtures, ceilings and miscellaneous items. When dimensional changes are required in these situations, the Contractor shall submit a proposed modification drawing to the Architect for review prior to proceeding with the work. All causes and effects of the dimensional change shall be indicated on the Contractor's drawing submittal.

1.4 SAMPLES

- A. Submit a full range of requested manufacturer's colors, textures, and patterns for Architect's selection. Submit samples for selection of finishes in accordance with approved schedule, and in such sequence as to cause no delay in the work or in the work of any other Contractor.
- B. Submit samples to illustrate functional characteristics of the product, with integral parts and attachment devices. Coordinate submittal of different categories for interfacing work.
- C. Submittals shall contain:
 - 1. Date of submission and dates of any previous submissions
 - 2. Project title and number
 - 3. Contract identification
 - 4. Names of Contractor, Supplier, Manufacturer
 - 5. Identification of sample, with specification section number
- D. Resubmission Requirements for Samples:
 - 1. Make any corrections or changes in the submittals required by the Architect and resubmit until approved. Refer to paragraph 1.2.I above.
 - 2. Submit new samples as required for initial submittal.

- E. Submit the number specified in the respective Specification section; minimum of two, one will be retained by Architect. Reviewed samples may be used in the work if so indicated in the specification section.

1.5 MANUFACTURER'S CERTIFICATES AND WARRANTIES

- A. Submit required certificates and warranties in duplicate.

END OF SECTION

SECTION 01310 - CONSTRUCTION SCHEDULE

CONDITIONS OF THE CONTRACT AND DIVISION 1, as indexed, apply to this Section.

PART 1 - GENERAL

1.1 SCOPE

- A. The construction schedule is of critical importance to Galveston County.
- B. Immediately after award of a contract the Construction Manager will work with each Contractor on the project to develop a critical path schedule. The Contractor is required to participate in and cooperate with this effort and to comply with the developed schedule.
- C. The Contractor shall coordinate his schedule with the Construction Manager Agent so that the entire work proceeds smoothly and without interruption. Refer to Article 2 of the Contract for Construction.
- D. The Contractor shall start the work upon notice to proceed and shall execute the work with diligence and dispatch so as to maintain such schedules and milestones as established in cooperation with the Construction Manager.
- E. Galveston County does not have any restrictions on the days or hours of work that are allowed or required to comply with the schedule except that the Construction Manager, Project Superintendent, or designated representative must be present whenever a Contractor is performing work on the project.
- F. The Contractor shall report progress critical to maintaining the schedule at the weekly project meeting held by the Construction Manager.
- G. If it is determined by the Construction Manager that the Contractor is falling behind schedule he will notify the Contractor at the weekly meeting and the Contractor must provide a plan of action to maintain the previously agreed schedule.
- H. The Contractor is cautioned that schedules and milestones are subject to review and revision, and in such event, such revisions will be made available for the Contractor's information at the jobsite office of the Construction Manager.
- I. It is the responsibility of the Contractor to attend regular project meetings, keep itself informed of any revisions to the schedule, and conform to any such revisions to the schedule.

END OF SECTION

SECTION 01420 - NOTIFICATION OF ARCHITECT REQUIREMENTS

CONDITIONS OF THE CONTRACT AND DIVISION 1, as indexed, apply to this Section.

PART 1 - GENERAL

1.1 SCOPE

- A. The Architect and Consulting Engineers generally require 48 hours notice to plan their work and will be appreciative of your cooperation.
- B. In general, the Contractor shall notify the Architect whenever there is need of clarification or interpretation of the Contract Documents. This may be done without notice however, the Architect and/or Engineer may not be available immediately so plan ahead.
- C. The Contractor shall notify the Architect 48 hours in advance of certain stages of construction. The Contractors' Project Superintendent shall notify the Contractor on a regular basis of the ongoing work. These stages shall include, but not necessarily be limited to the following:
 - 1. 02225 - Demolition
 - 2. 03300 - Placing of all concrete
 - 3. 07100 - Concealment of flashing
 - 4. 07200 - Concealment of insulation
 - 5. 07500 - Roofing and sheet metal work
 - 6. 07900, 08800 - Installation of building and glazing sealants
 - 7. 09500 - Installation of ceiling grid
 - 8. 09900 - Painting and staining (each coat)
 - 9. 09600 - Installation of flooring
 - 10. 15000, 16000 - Completion of roughing-in of plumbing, heating, air conditioning and electrical work (prior to concealment)
 - 11. 16000 - Installation of all electrical fixtures
 - 12. 15000 - Installation of heating, ventilating and air conditioning
 - 13. 15000 - Installation of plumbing fixtures
 - 14. 15000, 16000 - Any and all testing specified for equipment, mechanical, electrical and plumbing systems

PART 2 - PROJECT MEETINGS

2.1 PRECONSTRUCTION CONFERENCE

- A. The Contractor shall contact the Architect at least ten (10) days prior to commencing construction, in order to schedule a pre-construction meeting with the Architect and Owner. This meeting must occur prior to commencement of any construction.

2.2 PROGRESS MEETINGS

- A. Contractor shall schedule and administer project meetings throughout progress of the work.
- B. Contractor will make physical arrangements for meetings, preside at meetings, record minutes, and distribute copies within two (2) days to the Architect, participants, and those affected by decisions made at meetings.
- C. Required Attendance: Contractor's Project Superintendent, Contractor's Project Manager, Owner, and Architect as appropriate to agenda topics for each meeting.
- D. Suggested Agenda: Review of work progress, status of progress schedule and adjustments thereto, delivery schedules, submittals, maintenance of quality standards, pending changes and substitutions, and other items affecting progress of work. This is a good time to review the upcoming Application for Payment.

2.3 PREINSTALLATION CONFERENCES

- A. For each individual Specification section or each subcontractor, convene a pre-installation conference prior to commencing work of that Section.
- B. Require attendance of entities directly affecting or affected by work of that section.
- C. Review conditions of installation, preparation and installation procedures, and coordinate with related work.

END OF SECTION

SECTION 01500 - TEMPORARY FACILITIES AND CONTROLS

CONDITIONS OF THE CONTRACT AND DIVISION 1, as indexed, apply to this Section.

PART 1 - GENERAL

1.1 QUALITY ASSURANCE

- A. Environmental Protection: Provide environmental protection as required by authorities having jurisdiction and as indicated in Contract Documents.

1.2 GENERAL TRADE CONTRACTOR REQUIREMENTS Contractor shall be responsible for furnishing, installing or otherwise providing any or all of the following temporary facilities, structures or services as they may be necessary or required for or during, performance of the work of his Contract

1. Temporary field office facilities complete, including all furniture, heat, cooling, lighting, telephone, plumbing and toilet fixtures as he may require for his exclusive use. (Site location and number are subject to approval of the Construction Manager).
2. Temporary storage facilities, sheds or buildings as may be required for the proper protection or storage of materials and/or equipment. (Site location and number are subject to approval of Construction Manager).
3. Temporary extension from, and hookup to, all temporary utilities during construction.
4. Maintenance, cleanup and removal of all temporary facilities.
5. Furnishing, erection, maintenance and removal of all temporary hoists and scaffolding as may be required for the performance of the work of his Contract.
6. All temporary facilities, structures, services or items of work specifically required or defined in the Scope of Work or otherwise required by the Contract Documents for his work.
7. Distribution of drinking water for his construction personnel.
8. At the end of the day's work, all work subject to damage by adverse weather conditions shall be covered or otherwise protected as required. Weather protection shall be adequate to permit Contractor to work on a continuous basis without shutdown due to temperature or weather conditions as far as possible.
9. No temporary service shall be removed or disconnected until the new parts have been installed to replace them, properly connected and ready for use. The changing over from temporary to permanent work shall be done expeditiously, and if possible so that no part of the building or premises shall be without adequate service.

1.3 TEMPORARY ELECTRICITY AND LIGHTING Owner will pay cost of energy used directly to utility. Exercise measures to conserve energy. Utilize Owner's existing power service.

- B. Provide temporary electric feeder from existing building electrical service at location as directed. Do not disrupt Owner's use of service.
- C. Complement existing power service capacity and characteristics as required.

- D. Connecting and disconnecting Contractor tools and equipment to (and from) the distribution system will be performed by qualified personnel, ALL grounding as required by the National Electrical Code, OSHA or any and all local codes, including approved ground fault interrupters shall be furnished and installed at the Contractors expense.
- E. The Contract will install temporary lighting in all areas and rooms. Temporary lighting shall be a minimum of 2 watt per square foot. For all areas 3,200 or less, 100-watt lamps spaced approximately at 20 foot centers shall be used. Each room or enclosed area shall have, at least, one lighting and one tool outlet. Where 100 watt lights are used, the outlets shall consist of double weatherproof sockets. One (1) socket shall be used for the 100-watt lamp and the other socket shall be used for portable power tools. Any temporary lighting required beyond the foregoing shall be provided by the party requiring the same and the work will be paid for by the Trade Contractor.

1.4 **TEMPORARY HEATING**

- A. It is not anticipated that the permanent building system will be utilized to provide "temporary heat" during the major portion of construction operations.
- B. Within these parameters the Trade Contractor must provide any supplemental heat required to perform his work
- C. Maintain minimum ambient temperature of 50 degrees F in areas where construction is in progress, unless indicated otherwise in product sections.
- D. It is anticipated that activation, testing and balancing of the building heating/cooling system will be critical to the completion and acceptance of the project and therefore actuation, of the permanent system will be scheduled for the earliest possible time

1.5 **TEMPORARY COOLING**

- A. Will not be provided.
- B. It is anticipated that activation, testing and balancing of the building heating/cooling system will be critical to the completion and acceptance of the project and therefore actuation, of the permanent system will be scheduled for the earliest possible time

1.6 **TEMPORARY VENTILATION**

- A. Ventilate enclosed areas to achieve curing of materials, to dissipate humidity, and to prevent accumulation of dust, fumes, vapors, or gases.
- B. Utilize existing ventilation equipment. Extend and supplement equipment with temporary fan units as required to maintain clean air for construction operations.

1.7 **TEMPORARY WATER SERVICE**

- A. Owner will pay cost of temporary water. Exercise measures to conserve energy. Utilize Owner's existing water system, extend and supplement with temporary devices as needed to maintain specified conditions for construction operations.
- B. Extend branch piping with outlets located so water is available by hoses with threaded connections. Provide temporary pipe insulation to prevent freezing.
- C. Potable water is available to the Contractor at a central location. Extensions of the water supply for Contractor's exclusive use shall be the responsibility of the Contractor.

1.8 **TEMPORARY SANITARY FACILITIES**

- A. The Construction Manager will provide temporary toilets, excluding Contractor's trailer hookup.
- B. The Contract will provide rubbish containers and rubbish disposal service.

1.9 **FIELD OFFICES AND SHEDS**

- A. Designated existing spaces may be used for field offices and for storage:
- B. Provide space for Project meetings, with table and chairs to accommodate 6 persons.
- C. Storage Areas And Sheds: Size to storage requirements for products of individual Sections, allowing for access and orderly provision for maintenance and for inspection of products to requirements of Section 01600.
- D. Maintenance And Cleaning: Daily janitorial services for offices; periodic cleaning and maintenance for office and storage areas. Maintain approach walks free of mud, water, and snow.
- E. Removal: At completion of Work remove buildings, foundations, utility services, and debris. Restore areas.

1.10 **VEHICULAR ACCESS**

- A. Provide unimpeded access for emergency vehicles. Maintain 20-foot width driveways with turning space between and around combustible materials.
- B. Provide and maintain access to fire hydrants and control valves free of obstructions.

1.11 **PARKING**

- A. Use of designated existing on-site streets and driveways used for construction traffic is permitted. Tracked vehicles not allowed on paved areas.
- B. Use of designated areas of existing parking facilities used by construction personnel is permitted.
- C. Do not allow heavy vehicles or construction equipment in parking areas.
- D. Maintenance:
 - 1. Maintain traffic and parking areas in a sound condition free of excavated material, construction equipment, products, mud, snow, and ice.
 - 2. Maintain existing and permanent paved areas used for construction; promptly repair breaks, potholes, low areas, standing water, and other deficiencies, to maintain paving and drainage in original, or specified, condition.
- E. Removal, Repair:
 - 1. Repair existing facilities damaged by use, to original condition.

1.12 **PROGRESS CLEANING AND WASTE REMOVAL**

- A. Salvage nonhazardous demolition and construction waste and recycle.

- B. **Maintain areas free of waste materials, debris, and rubbish on a daily basis. Maintain site in a clean and orderly condition on a daily basis.**
- C. Remove debris and rubbish from pipe chases, plenums, attics, crawl spaces, and other closed or remote spaces, on a daily basis and prior to enclosing the space.
- D. Broom and vacuum clean interior areas prior to start of surface finishing, and continue cleaning to eliminate dust.
- E. **Collect and remove waste materials, debris, and rubbish from site daily and dispose off-site.**

1.13 **TRAFFIC REGULATION**

- A. Signs, Signals, And Devices:
 - 1. Post Mounted and Wall Mounted Traffic Control and Informational Signs: As approved by local jurisdictions.
 - 2. Automatic Traffic Control Signals: As approved by local jurisdictions.
 - 3. Traffic Cones and Drums, Flares and Lights: As approved by local jurisdictions.
 - 4. Flag-person Equipment: As required by local jurisdictions.
- B. Flag Persons: Provide trained and equipped flag persons to regulate traffic when construction operations or traffic encroach on public traffic lanes.
- C. Flares and Lights: Use flares and lights during hours of low visibility to delineate traffic lanes and to guide traffic.
- D. Haul Routes: Consult with authority having jurisdiction, establish public thoroughfares to be used for haul routes and site access.

1.14 **BARRIERS**

- A. Protect non-owned vehicular traffic, stored materials, site, and structures from damage.

1.15 **ENCLOSURES AND FENCING**

- A. Contractor may provide fence around construction site; equipped with vehicular and pedestrian gates with locks.

1.16 **SECURITY**

- A. Security Program:
 - 1. Protect work, existing premises, and Owner's operations from theft, vandalism, and unauthorized entry.
 - 2. Maintain program throughout construction period until Owner acceptance precludes the need for Contractor security.
- B. Entry Control:
 - 1. Restrict entrance of persons and vehicles into Project site and existing facilities.

2. Allow entrance only to authorized persons with proper identification.
3. Maintain log of workers and visitors, make available to Owner on request.
4. Coordinate access of Owner's personnel to site in coordination with Owner's security forces.

C. Restrictions:

1. Do not allow cameras on site or photographs taken except by written approval of Owner.
The Contractor will provide temporary fire safety equipment for general use.

D. Site Security, Personnel and Property Protection

1. Contractor shall maintain the security of the worksite and shall restrict access to the site to the following:
 - a. its employees;
 - b. employees of subcontractors;
 - c. representatives of manufacturers whose goods are utilized in the work and are called to the site by either the Contractor or the Program Administrator; and
 - d. agents and/or employees of the County.
2. Contractor shall provide adequate protection to persons on the worksite, adjacent properties, and utilities as is necessary to keep each free of damage or injury.
3. Contractor shall take proper means to protect adjacent or adjoining properties which might be injured or seriously affected by construction undertaken under this Agreement from any damage or injury by reason of said process of construction. Contractor shall be liable for any and all claims for such damage on account of its failure to fully protect all adjoining properties.
4. When performing any cutting, removal, creating opening or holes, etc., the Contractor, by use of barricades, flagmen, or other means, shall provide protective measures to assure that other workmen or the public are not exposed to potential injury by the operation being conducted.
5. The Contractor shall be responsible for handling and transporting (including lifting) his material and equipment to the location of need in a timely manner.

1.17 **DUST CONTROL**

- A. Execute Work by methods to minimize raising dust from construction operations.
- B. Provide positive means to prevent air-borne dust from dispersing into atmosphere.

1.18 **NOISE CONTROL**

- A. Provide methods, means, and facilities to minimize noise from noise produced by construction operations.

1.19 **PEST CONTROL**

- A. Provide methods, means, and facilities to prevent pests and insects from entering the facility.

1.20 **POLLUTION CONTROL**

- A. Provide methods, means, and facilities to prevent contamination of soil, water, and atmosphere from discharge of noxious, toxic substances, and pollutants produced by construction operations.

1.21 **RODENT CONTROL**

- A. Provide methods, means, and facilities to prevent rodents from accessing or invading premises.

1.22 **HOUSEKEEPING - CLEANING AND RUBBISH REMOVAL**

- A. **Contractor shall be responsible for daily and final cleanup and continuous removal of all rubbish and debris from the building and site.**
- B. The jobsite shall be maintained in a neat orderly condition and kept free from accumulations of waste materials and rubbish during the entire construction period. Contractor will remove all crates, cartons and other flammable waste materials or trash from the work areas at the end of each working day.
- C. Electrical closets, pipe and duct shafts, chases, furred spaces and similar spaces which are generally unfinished, shall be cleaned and left free from rubbish, loose plaster, mortar drippings, extraneous construction materials, dirt and dust before substantial completion review.
- D. Contractor shall be responsible for cleaning all surfaces as necessary to make them free of spatters or other deposits of paint, plaster, mortar, concrete, adhesives, roofing, dirt, soil, oil, or any other material foreign to the surface involved.
- E. The Contractor shall be responsible to maintain his own trailer, storage and work areas in a sanitary condition to minimize the hazard of attracting vermin and breeding mosquitoes. Rodent extermination materials shall be those approved by the local health department or other agency having jurisdiction.
- F. Use only cleaning materials and methods recommended by manufacturer of surface to be cleaned. Use cleaning materials only on surfaces recommended by cleaning material manufacturer. Each Contractor shall be responsible for assuring that affected employees are provided with, and required to use, all needed personal protective devices in connection with cleaning.
- G. At completion of work, Contractor shall remove tools, equipment, machinery, and surplus materials from the project site and perform whatever additional cleaning is required.
- B. Vehicle cleaning - Trucking
 - 1. Cleaning of concrete equipment shall be performed off site. Cleaning shall be conducted in such a manner as to prevent spillage of fluid or concrete to the ground or penetration of existing ground soil.

1.23 **REMOVAL OF UTILITIES, FACILITIES, AND CONTROLS**

- A. Remove temporary utilities, equipment, facilities, materials, prior to Substantial Completion inspection.

- B. Clean and repair damage caused by installation or use of temporary work.
- C. Restore existing and permanent facilities used during construction to original condition. Restore permanent facilities used during construction to specified condition.

END OF SECTION

SECTION 01630 - SUBSTITUTIONS

CONDITIONS OF THE CONTRACT AND DIVISION 1, as indexed, apply to this Section

PART 1 – GENERAL

1.1 SCOPE

- A. Comply with all requirements of the Contract Documents, including, but not limited to, specified sizes, dimensions, materials, finishes, products, manufacturers, suppliers, brands, processes, procedures, tolerances, sequences, etc.
- B. If, for some reason, all the multiple requirements cannot be met and the Bidder wishes to request a substitution of products in place of those specified, the Bidder may make a formal request to the Architect for consideration.
- C. Substitution of products considered and accepted by the Owner and Architect will be included in addenda prior to the proposal date. Request must be made at least ten (10) days prior to the proposal date to be included in addenda.

1.2 BIDDER

- A. By making requests for substitutions the Bidder represents that he has personally investigated the proposed substitute product and determined that it is equal or superior in all respects to that specified.
- B. The Bidder represents that he will provide the same warranty for the substitute product that would have provided for the specified product.
- C. The Bidder certifies that the cost data presented is complete and includes all related costs under this Contract except the Architect's redesign cost and waives all claims for additional costs related to the substitution that subsequently become apparent.
- D. The Bidder will coordinate the installation of the accepted substitute and make such changes as may be required for the Work to be completed in all respects.
- E. The Bidder will notify the Architect of any space accommodations required by a substitution.
- F. The Bidder will notify the Architect of any known disadvantage as compared to the specified item.
- G. The Bidder will submit justifying data on which the Architect can base a decision.

1.3 ARCHITECTS DUTIES AND RESPONSIBILITIES

- A. The Architect has no obligation to entertain any proposed substitution unless the Contract can not be fulfilled under the original requirements.
- B. The Architect will analyze only proposed substitutions that he perceives likely to benefit the Owner by lower costs, improved quality or saving time.

1.4 PROPOSED SUBSTITUTIONS DURING BID PERIOD

- A. Request must be submitted to the Architect in sufficient time before the proposal date to permit evaluation and notifying Bidder, if approved. This time is a minimum of ten (10) day prior to proposal date.
- B. Substitutions, if approved, will be by written Addenda to all Bidders. No oral, telephonic, or other method will be used to acknowledge accepted substitutions. If it is not in addenda it is not acceptable to include it in a bid.

1.5 PROPOSED SUBSTITUTIONS AFTER CONTRACT AWARD

- A. Must be submitted so as not to interfere with the completion of the Work, and within 30 days after the Contract Date, except for emergencies.
- B. Substitutions, if approved, will be by Change Order.

1.6 VOLUNTARY ALTERNATE BID SUBSTITUTIONS

- A. Will not be accepted. Additions of such voluntary alternate bids may make the bid void.

END OF SECTION

SECTION 01710 - GUARANTEES, CERTIFICATES AND CLOSE-OUT

CONDITIONS OF THE CONTRACT AND DIVISION 1, as indexed, apply to this Section.

PART 1 - GENERAL

1.1 SCOPE

- A. Contractor shall be responsible for and make good without extra charge any defects due to faults in labor or material on all parts of the Contract for one year (and longer where noted) after Substantial Completion of the Work as defined in the General Conditions.
- B. Property not in the Contract but damaged due to defects, shall be repaired or replaced by the Contractor without extra charge.
- C. When notified by the Owner or Architect that a defect exists and there is a doubt that the defect might be normal maintenance or a result of lack of normal maintenance, the Owner will send a representative with the Contractor's representative to determine responsibility. Owner will not pay for such service calls if the defect is judged to be normal maintenance or a result of a lack of normal maintenance.
- D. Neither the Final Certificate of Payment or payment of same, nor provision in the Contract Documents shall relieve the Contractor of the responsibility for negligence or faulty materials or workmanship within the extent and period provided by law and upon written notice, he shall remedy any defects due thereto and pay all expenses for any damage to other Work resulting there from. This guarantee of Work shall not relieve the Contractor of obligations of any Work not according to Plans and Specifications regardless of time of discovery.

1.2 WARRANTY

- A. In addition to the General Contractor's one-year warranty, guarantees shall be submitted to the Architect in duplicate prior to application for final payment. Unless specified otherwise in their respective sections, all guarantees shall be for a period of one year from the date of Substantial Completion as evidenced by the Architect's Certificate of Substantial Completion. All guarantees shall include all labor, material and delivery costs required to correct defective material or installation. Guarantees include but are not limited to:
 - 2. Custom Hollow Metal
 - 3. Dampproofing and waterproofing (2-year)
 - 4. Sealants (2-year)
- B. Refer to Section 01630 for substitutions.

1.3 SUBSTANTIAL COMPLETION AND CLOSE-OUT

- A. On or about the end of the project, the following items shall be performed in order to achieve Substantial Completion and project close-out:
 - 1. Contractor submits a thorough list of items to be completed or corrected (Punch List), along with a written request for Substantial Completion and inspection of the work.
 - 2. The Architect and Engineer will inspect the project utilizing the Contractor's prepared Punch List, noting completed or incomplete items, and prepare a supplemental list of items that have been omitted or incomplete items that were not previously noted. The Architect's Project Representative, at his discretion, may attend and assist in the preparation of the Contractor's punch list.
 - 3. Contractor completes corrections, and Architect and Engineer re-inspect (with Owner) to establish Date of Substantial Completion. **Note:** Any items remaining on date of Substantial Completion are appended to Certificate (AIA G-704).
 - 4. After the Certificate of Substantial Completion has been executed by all parties, it is returned to the Architect. Items on the appended Punch List are to be completed or corrected within the time limits established in the Certificate of Substantial Completion.

5. Final Change Order executed (including allowance adjustments).
 6. Contractor submits written notice that work is ready for final inspection and acceptance, and shall specifically note each item on the Punch List as being complete or the status of any incomplete item.
 7. Contractor submits Final Application for Payment and a Certificate of Compliance, which indicates the following:
 - a. All Permit Numbers
 - b. Utility Release Dates
 - c. The building has been duly inspected and found to comply with all code requirements and ordinances.
 - d. A Certificate of Occupancy has been issued.
 8. A-E (with Owner) make final inspection
 9. Contractor submits additional final items:
 - a. Consent of Surety to Final Payment (AIA G-707)
 - b. Contractor's Affidavit of Payment of Debts and Claims (AIA G-706)
 - c. Contractor's Affidavit of Release of Liens (AIA G-706A with contractors, subcontractors and suppliers separate releases)
 - d. General Contractor's Guarantee
 - e. Subcontractors' Guarantees.
 - f. Maintenance and Instruction Manuals. All manuals will contain an index listing the information submitted. The index sections will be divided and identified by tabbing each section as listed in the index.
 - g. Record Drawings (reproducible sepias)
 - h. Final List of Subcontractors (AIA G-805)
 - i. Affidavits from Contractor Subcontractors and suppliers stating that no asbestos products have been installed in this project.
 - j. Furnish written warranties to the Owner including specific items in each product warranty stipulated for individual sections.
 - k. Documents identified as "affidavit" must be notarized.
 10. Final Cleaning:
 - a. The work area shall be thoroughly cleaned inside and outside. Cleaning includes removal of smudges, marks, stains, fingerprints, soil, dirt, spots, dust, lint, and other foreign materials from finished and exposed surfaces.
 - b. Remove all temporary facilities.
- B. All close-out documents shall be submitted in three ring binders with index tabs, detailed Table of Contents and page numbers. The close-out documents must be neatly organized and easily useable, as determined by the Architect and Owner.
- C. Final release of retainage will not be certified by the Architect until the Contractor completes all of the above mentioned requirements.
- D. Terminal Inspection:
1. Immediately prior to expiration of the one-year guarantee period, the Contractor shall make an inspection of the work in the company of the Architect and the Owner. The Architect and the Owner shall be given not less than ten (10) days notice prior to the anticipated date of terminal inspection.
 2. Where any portion of the work has proven to be defective and requires replacement, repair or adjustment, the Contractor shall immediately provide materials and labor necessary to remedy such defective work, and shall execute such work without delay until completed to the satisfaction of the Architect and the Owner, even though the date of completion of the corrective work may extend beyond the expiration date of the guarantee period.
 3. The Contractor shall not be responsible for correction of work which has been damaged because of neglect or abuse by the Owner, nor the replacement of parts necessitated by normal wear in use.

END OF SECTION

SECTION 01250 - CONTRACT MODIFICATION PROCEDURES

PART 1 - GENERAL

1.01 RELATED DOCUMENTS

- A. Drawings and general provisions of the Contract, including General and Supplementary Conditions and other Division 1 Specification Sections, apply to this Section.

1.02 SUMMARY

- A. Section specifies administrative and procedural requirements for handling and processing Contract modifications.
- B. Related Sections include:
 - 1. Division 1 Section "Allowances" for procedural requirements for handling and processing allowances.
 - 2. Division 1 Section "Product Requirements" for administrative procedures for handling requests for substitutions made after Contract award.

1.03 MINOR CHANGES IN THE WORK

- A. Architect will issue supplemental instructions authorizing Minor Changes in the Work, not involving adjustment to the Contract Sum or the Contract Time, on AIA Document G710, "Architect's Supplemental Instructions."

1.04 PROPOSAL REQUESTS

- A. Owner-Initiated Proposal Requests: The Architect will issue a detailed description of proposed changes in the Work that may require adjustment to the Contract Sum or the Contract Time. If necessary, the description will include supplemental or revised Drawings and Specifications.
 - 1. Proposal Requests issued by the Architect are for information only. Do not consider them instructions either to stop work in progress or to execute the proposed change.
 - 2. Within time specified in Proposal Request after receipt of Proposal Request, submit a quotation estimating cost adjustments to the Contract Sum and the Contract Time necessary to execute the change.
 - a. Include a list of quantities of products required or eliminated and unit costs, with total amount of purchases and credits to be made. If requested, furnish survey data to substantiate quantities.
 - b. Indicate applicable taxes, delivery charges, equipment rental, and amounts of trade discounts.
 - c. Include an updated Contractor's Construction Schedule that indicates the effect of the change, including, but not limited to, changes in activity duration, start and finish times, and activity relationship. Use available total float before requesting an extension of the Contract Time.
- B. Contractor-Initiated Proposals: If latent or unforeseen conditions require modifications to the Contract, Contractor may propose changes by submitting a request for a change.
 - 1. Include a statement outlining reasons for the change and the effect of the change on the Work. Provide a complete description of the proposed change. Indicate the effect of the proposed change on the Contract Sum and the Contract Time.

2. Include a list of quantities of products required or eliminated and unit costs, with total amount of purchases and credits to be made. If requested, furnish survey data to substantiate quantities.
 3. Indicate applicable taxes, delivery charges, equipment rental, and amounts of trade discounts.
 4. Include an updated Contractor's Construction Schedule that indicates the effect of the change, including, but not limited to, changes in activity duration, start and finish times, and activity relationship. Use available total float before requesting an extension of the Contract Time.
 5. Comply with requirements in Division 1 Section "Product Requirements" if the proposed change requires substitution of one product or system for product or system specified.
- C. Proposal Request Form: Use AIA Document G709 for Proposal Requests.

1.05 ALLOWANCES

- A. Allowance Adjustment: To adjust allowance amounts, base each Change Order proposal on the difference between purchase amount and the allowance, multiplied by final measurement of work-in-place. If applicable, include reasonable allowances for cutting losses, tolerances, mixing wastes, normal product imperfections, and similar margins.
1. Include installation costs in purchase amount only where indicated as part of the allowance.
 2. If requested, prepare explanation and documentation to substantiate distribution of overhead costs and other margins claimed.
 3. Submit substantiation of a change in scope of work, if any, claimed in Change Orders related to unit-cost allowances.
 4. Owner reserves the right to establish the quantity of work-in-place by independent quantity survey, measure, or count.
- B. Submit claims for increased costs because of a change in scope or nature of the allowance described in the Contract Documents, whether for the Purchase Order amount or Contractor's handling, labor, installation, overhead, and profit. Submit claims within 21 days of receipt of the Change Order or Construction Change Directive authorizing work to proceed. Owner will reject claims submitted later than 21 days after such authorization.
1. Do not include Contractor's or subcontractor's indirect expense in the Change Order cost amount unless it is clearly shown that the nature or extent of work has changed from what could have been foreseen from information in the Contract Documents.
 2. No change to Contractor's indirect expense is permitted for selection of higher- or lower-priced materials or systems of the same scope and nature as originally indicated.

1.06 CHANGE ORDER PROCEDURES

- A. On Owner's approval of a Proposal Request, Architect will issue a Change Order for signatures of Owner and Contractor on AIA Document G701.

1.07 CONSTRUCTION CHANGE DIRECTIVE

- A. Construction Change Directive: Architect may issue a Construction Change Directive on AIA Document G714. Construction Change Directive instructs Contractor to proceed with a change in the Work, for subsequent inclusion in a Change Order.
1. Construction Change Directive contains a complete description of change in the Work. It also designates method to be followed to determine change in the Contract Sum or the Contract Time.

- B. Documentation: Maintain detailed records on a time and material basis of work required by the Construction Change Directive.
1. After completion of change, submit an itemized account and supporting data necessary to substantiate cost and time adjustments to the Contract.

END OF SECTION

SECTION 01290 - PAYMENT PROCEDURES

PART 1 - GENERAL

1.01 RELATED DOCUMENTS

- A. Drawings and general provisions of the Contract, including General and Supplementary Conditions and other Division 1 Specification Sections, apply to this Section.

1.02 SUMMARY

- A. Section specifies administrative and procedural requirements necessary to prepare and process Applications for Payment.
- B. Related Sections include:
 - 1. Division 1 Section "Allowances" for procedural requirements governing handling and processing of allowances.
 - 2. Division 1 Section "Contract Modification Procedures" for administrative procedures for handling changes to the Contract.
 - 3. Division 1 Section "Construction Progress Documentation" for administrative requirements governing preparation and submittal of Contractor's Construction Schedule and Submittals Schedule.

1.03 DEFINITIONS

- A. Schedule of Values: A statement furnished by Contractor allocating portions of the Contract Sum to various portions of the Work and used as the basis for reviewing Contractor's Applications for Payment.

1.04 SCHEDULE OF VALUES

- A. Coordination: Coordinate preparation of the Schedule of Values with preparation of Contractor's Construction Schedule.
 - 1. Correlate line items in the Schedule of Values with other required administrative forms and schedules, including the following:
 - a. Application for Payment forms with Continuation Sheets.
 - b. Submittals Schedule.
 - 2. Submit the Schedule of Values to Architect at earliest possible date but no later than 7 days before the date scheduled for submittal of initial Applications for Payment.
 - 3. Subschedules: Where the Work is separated into phases requiring separately phased payments, provide subschedules showing values correlated with each phase of payment.
- B. Format and Content: Use the Project Manual table of contents as a guide to establish line items for the Schedule of Values.
 - 1. Identification: Include the following Project identification on the Schedule of Values:
 - a. Project name and location.
 - b. Name of Architect.
 - c. Architect's project number.
 - d. Contractor's name and address.
 - e. Date of submittal.

2. Arrange the Schedule of Values in tabular form with separate columns to indicate the following for each item listed:
 - a. Related Specification Section or Division.
 - b. Description of the Work.
 - c. Name of subcontractor.
 - d. Name of manufacturer or fabricator.
 - e. Name of supplier.
 - f. Change Orders (numbers) that affect value.
 - g. Dollar value. Round amounts to nearest whole dollar; total shall equal the Contract Sum.
 - h. Percentage of the Contract Sum to nearest one-hundredth percent, adjusted to total 100 percent.
3. Breakdown of Contract Sum: Provide enough detail to facilitate continued evaluation of Applications for Payment and progress reports. Coordinate with the Project Manual table of contents. Provide several line items for principal subcontract amounts, where appropriate.
 - a. Provide at least one line item for each Specification Section or major subcontract.
4. Provide a separate line item in the Schedule of Values for each part of the Work where Applications for Payment may include materials or equipment purchased or fabricated and stored, but not yet installed.
 - a. Differentiate between items stored on-site and items stored off-site. Include evidence of insurance or bonded warehousing if required.
5. Provide separate line items in the Schedule of Values for initial cost of materials, for each subsequent stage of completion, and for total installed value of that part of the Work.
6. Allowances: Provide a separate line item in the Schedule of Values for each allowance. Show line-item value of unit-cost allowances, as a product of the unit cost, multiplied by measured quantity. Use information indicated in the Contract Documents to determine quantities.
7. Each item in the Schedule of Values and Applications for Payment shall be complete. Include total cost and proportionate share of general overhead and profit for each item.
 - a. Temporary facilities and other major cost items that are not direct cost of actual work-in-place may be shown either as separate line items in the Schedule of Values or distributed as general overhead expense, at Contractor's option.
8. Schedule Updating: Update and resubmit the Schedule of Values before the next Applications for Payment when Change Orders or Construction Change Directives result in a change in the Contract Sum.

1.05 APPLICATIONS FOR PAYMENT

- A. Each Application for Payment shall be consistent with previous applications and payments as certified by Architect and Construction Manager and paid for by Owner.
 1. Initial Application for Payment, Application for Payment at time of Substantial Completion, and final Application for Payment involve additional requirements.
- B. Payment Application Times: The date for each progress payment is indicated in the Agreement between Owner and Contractor. The period of construction Work covered by each Application for Payment is the period indicated in the Agreement.

- C. Payment Application Forms: Use AIA Document G702 and AIA Document G703 Continuation Sheets as form for Applications for Payment.
- D. Application Preparation: Complete every entry on form. Notarize and execute by a person authorized to sign legal documents on behalf of Contractor. Architect will return incomplete applications without action.
 - 1. Entries shall match data on the Schedule of Values and Contractor's Construction Schedule. Use updated schedules if revisions were made.
 - 2. Include amounts of Change Orders and Construction Change Directives issued before last day of construction period covered by application.
- E. Transmittal: Submit 3 signed and notarized original copies of each Application for Payment to Architect by a method ensuring receipt (within 24 hours). All copies shall include waivers of lien and similar attachments if required.
 - 1. Transmit each copy with a transmittal form listing attachments and recording appropriate information about application.
- F. Waivers of Mechanic's Lien: With each Application for Payment, submit waivers of mechanic's liens from subcontractors, sub-subcontractors, and suppliers for construction period covered by the previous application.
 - 1. Submit partial waivers on each item for amount requested, before deduction for retainage, on each item.
 - 2. When an application shows completion of an item, submit final or full waivers.
 - 3. Owner reserves the right to designate which entities involved in the Work must submit waivers.
 - 4. Waiver Delays: Submit each Application for Payment with Contractor's waiver of mechanic's lien for construction period covered by the application.
 - a. Submit final Application for Payment with or preceded by final waivers from every entity involved with performance of the Work covered by the application who is lawfully entitled to a lien.
 - 5. Waiver Forms: Submit waivers of lien on forms, executed in a manner acceptable to Owner.
- G. Initial Application for Payment: Administrative actions and submittals that must precede or coincide with submittal of first Application for Payment include the following:
 - 1. List of subcontractors.
 - 2. Schedule of Values.
 - 3. Contractor's Construction Schedule (preliminary if not final).
 - 4. Products list.
 - 5. Schedule of unit prices.
 - 6. Submittals Schedule (preliminary if not final).
 - 7. List of Contractor's staff assignments.
 - 8. List of Contractor's principal consultants.
 - 9. Copies of building permits.
 - 10. Copies of authorizations and licenses from authorities having jurisdiction for performance of the Work.
 - 11. Initial progress report.
 - 12. Report of preconstruction conference.

13. Certificates of insurance and insurance policies.
 14. Performance and payment bonds.
 15. Data needed to acquire Owner's insurance.
 16. Initial settlement survey and damage report if required.
- H. Application for Payment at Substantial Completion: After issuing the Certificate of Substantial Completion, submit an Application for Payment showing 100 percent completion for portion of the Work claimed as substantially complete.
1. Include documentation supporting claim that the Work is substantially complete and a statement showing an accounting of changes to the Contract Sum.
 2. This application shall reflect Certificates of Partial Substantial Completion issued previously for Owner occupancy of designated portions of the Work.
- I. Final Payment Application: Submit final Application for Payment with releases and supporting documentation not previously submitted and accepted, including, but not limited, to the following:
1. Evidence of completion of Project closeout requirements.
 2. Insurance certificates for products and completed operations where required and proof that taxes, fees, and similar obligations were paid.
 3. Updated final statement, accounting for final changes to the Contract Sum.
 4. AIA Document G706, "Contractor's Affidavit of Payment of Debts and Claims."
 5. AIA Document G706A, "Contractor's Affidavit of Release of Liens."
 6. AIA Document G707, "Consent of Surety to Final Payment."
 7. Evidence that claims have been settled.
 8. Final meter readings for utilities, and similar data as of date of Substantial Completion or when Owner took possession of and assumed responsibility for corresponding elements of the Work.
 9. Final, liquidated damages settlement statement.

END OF SECTION

SECTION 01310 - PROJECT MANAGEMENT AND COORDINATION

PART 1 - GENERAL

1.01 RELATED DOCUMENTS

- A. Drawings and general provisions of the Contract, including General and Supplementary Conditions and other Division 1 Specification Sections, apply to this Section.

1.02 SUMMARY

- A. Section includes administrative provisions for coordinating construction operations on Project including:
 - 1. General project coordination procedures.
 - 2. Conservation.
 - 3. Coordination Drawings.
 - 4. Administrative and supervisory personnel.
 - 5. Project meetings.
- B. Related Sections include:
 - 1. Division 1 Section "Construction Progress Documentation" for preparing and submitting the Contractor's Construction Schedule.
 - 2. Division 1 Section "Execution Requirements" for procedures for coordinating general installation and field-engineering services, including establishment of benchmarks and control points.
 - 3. Division 1 Section "Closeout Procedures" for coordinating Contract closeout.

1.03 COORDINATION

- A. Coordinate construction operations included in various Sections of the Specifications to ensure efficient and orderly installation of each part of the Work. Coordinate construction operations, included in different Sections, that depend on each other for proper installation, connection, and operation.
 - 1. Schedule construction operations in sequence required to obtain the best results where installation of one part of the Work depends on installation of other components, before or after its own installation.
 - 2. Coordinate installation of different components with other contractors to ensure maximum accessibility for required maintenance, service, and repair.
 - 3. Make adequate provisions to accommodate items scheduled for later installation.
- B. If necessary, prepare memoranda for distribution to each party involved, outlining special procedures required for coordination. Include such items as required notices, reports, and list of attendees at meetings.
 - 1. Prepare similar memoranda for Owner and separate contractors if coordination of their Work is required.
- C. Coordinate scheduling and timing of required administrative procedures with other construction activities and activities of other contractors to avoid conflicts and to ensure orderly progress of the Work. Such administrative activities include, but are not limited to, the following:
 - 1. Preparation of Contractor's Construction Schedule.

2. Preparation of the Schedule of Values.
 3. Installation and removal of temporary facilities and controls.
 4. Delivery and processing of submittals.
 5. Progress meetings.
 6. Preinstallation conferences.
 7. Project closeout activities.
- D. Coordinate construction activities to ensure that operations are carried out with consideration given to conservation of energy, water, and materials.
1. Salvage materials and equipment involved in performance of, but not actually incorporated into, the Work.

1.04 SUBMITTALS

- A. Coordination Drawings: Prepare Coordination Drawings if limited space availability necessitates maximum utilization of space for efficient installation of different components or if coordination is required for installation of products and materials fabricated by separate entities.
1. Indicate relationship of components shown on separate Shop Drawings.
 2. Indicate required installation sequences.
 3. Refer to Division 15 Section "Basic Mechanical Materials and Methods" and Division 16 Section "Basic Electrical Materials and Methods" for specific Coordination Drawing requirements for mechanical and electrical installations.

1.05 PROJECT MEETINGS

- A. General: Schedule and conduct meetings and conferences at Project site, unless otherwise indicated.
1. Attendees: Inform participants and others involved, and individuals whose presence is required, of date and time of each meeting. Notify Owner and Architect of scheduled meeting dates and times.
 2. Agenda: Prepare the meeting agenda. Distribute the agenda to all invited attendees.
 3. Record significant discussions and agreements achieved. Distribute the meeting minutes to everyone concerned, including Owner and Architect, within 3 days of the meeting.
- B. Schedule a preconstruction conference before starting construction, at a time convenient to Owner and Architect, but no later than 15 days after execution of the Agreement. Hold the conference at Project site or another convenient location. Conduct the meeting to review responsibilities and personnel assignments.
1. Attendees: Authorized representatives of Owner, Architect, and their consultants; Contractor and its superintendent; major subcontractors; manufacturers; suppliers; and other concerned parties shall attend the conference. All participants at the conference shall be familiar with Project and authorized to conclude matters relating to the Work.
 2. Agenda: Discuss items of significance that could affect progress, including the following:
 - a. Tentative construction schedule.
 - b. Phasing.
 - c. Critical work sequencing.
 - d. Designation of responsible personnel.
 - e. Procedures for processing field decisions and Change Orders.

- f. Procedures for processing Applications for Payment.
 - g. Distribution of the Contract Documents.
 - h. Submittal procedures.
 - i. Preparation of Record Documents.
 - j. Use of the premises.
 - k. Responsibility for temporary facilities and controls.
 - l. Parking availability.
 - m. Office, work, and storage areas.
 - n. Equipment deliveries and priorities.
 - o. First aid.
 - p. Security.
 - q. Progress cleaning.
 - r. Working hours.
- C. Preinstallation Conferences: Conduct a preinstallation conference at Project site before each construction activity that requires coordination with other construction.
1. Attendees: Installer and representatives of manufacturers and fabricators involved in or affected by the installation and its coordination or integration with other materials and installations that have preceded or will follow, shall attend the meeting. Advise Architect of scheduled meeting dates.
 2. Agenda: Review progress of other construction activities and preparations for the particular activity under consideration, including requirements for the following:
 - a. Contract Documents.
 - b. Options.
 - c. Related Change Orders.
 - d. Purchases.
 - e. Deliveries.
 - f. Submittals.
 - g. Review of mockups.
 - h. Possible conflicts.
 - i. Compatibility problems.
 - j. Time schedules.
 - k. Weather limitations.
 - l. Manufacturer's written recommendations.
 - m. Warranty requirements.
 - n. Compatibility of materials.
 - o. Acceptability of substrates.
 - p. Temporary facilities and controls.
 - q. Space and access limitations.
 - r. Regulations of authorities having jurisdiction.
 - s. Testing and inspecting requirements.
 - t. Required performance results.
 - u. Protection of construction and personnel.

3. Record significant conference discussions, agreements, and disagreements.
 4. Do not proceed with installation if the conference cannot be successfully concluded. Initiate whatever actions are necessary to resolve impediments to performance of the Work and reconvene the conference at earliest feasible date.
- D. Progress Meetings: Conduct progress meetings at regular intervals. Coordinate dates of meetings with preparation of payment requests.
1. Attendees: In addition to representatives of Owner and Architect, each contractor, subcontractor, supplier, and other entity concerned with current progress or involved in planning, coordination, or performance of future activities shall be represented at these meetings. All participants at the conference shall be familiar with Project and authorized to conclude matters relating to the Work.
 2. Agenda: Review and correct or approve minutes of previous progress meeting. Review other items of significance that could affect progress. Include topics for discussion as appropriate to status of Project.
 - a. Contractor's Construction Schedule: Review progress since the last meeting. Determine whether each activity is on time, ahead of schedule, or behind schedule, in relation to Contractor's Construction Schedule. Determine how construction behind schedule will be expedited; secure commitments from parties involved to do so. Discuss whether schedule revisions are required to ensure that current and subsequent activities will be completed within the Contract Time.
 - b. Review present and future needs of each entity present, including the following:
 - (1) Interface requirements.
 - (2) Sequence of operations.
 - (3) Status of submittals.
 - (4) Deliveries.
 - (5) Off-site fabrication.
 - (6) Access.
 - (7) Site utilization.
 - (8) Temporary facilities and controls.
 - (9) Work hours.
 - (10) Hazards and risks.
 - (11) Progress cleaning.
 - (12) Quality and work standards.
 - (13) Change Orders.
 - (14) Documentation of information for payment requests.
 3. Reporting: Distribute minutes of the meeting to each party present and to parties who should have been present. Include a brief summary, in narrative form, of progress since the previous meeting and report.
 - a. Schedule Updating: Revise Contractor's Construction Schedule after each progress meeting where revisions to the schedule have been made or recognized. Issue revised schedule concurrently with the report of each meeting.

END OF SECTION

SECTION 01320 - CONSTRUCTION PROGRESS DOCUMENTATION

PART 1 - GENERAL

1.01 RELATED DOCUMENTS

- A. Drawings and general provisions of the Contract, including General and Supplementary Conditions and other Division 1 Specification Sections, apply to this Section.

1.02 SUMMARY

- A. Section includes administrative and procedural requirements for documenting the progress of construction during performance of the Work, including:
 - 1. Preliminary Construction Schedule.
 - 2. Contractor's Construction Schedule.
 - 3. Submittals Schedule.
- B. Related Sections include:
 - 1. Division 1 Section "Payment Procedures" for submitting the Schedule of Values.
 - 2. Division 1 Section "Project Management and Coordination" for submitting and distributing meeting and conference minutes.
 - 3. Division 1 Section "Submittal Procedures" for submitting schedules and reports.
 - 4. Division 1 Section "Quality Requirements" for submitting a schedule of tests and inspections.

1.03 DEFINITIONS

- A. Activity: A discrete part of a project that can be identified for planning, scheduling, monitoring, and controlling the construction project. Activities included in a construction schedule consume time and resources.
 - 1. Critical activities are activities on the critical path. They must start and finish on the planned early start and finish times.
 - 2. Predecessor activity is an activity that must be completed before a given activity can be started.
- B. CPM: Critical path method, which is a method of planning and scheduling a construction project where activities are arranged based on activity relationships. Network calculations determine when activities can be performed and the critical path of Project.
- C. Critical Path: The longest continuous chain of activities through the network schedule that establishes the minimum overall Project duration and contains no float.
- D. Event: The starting or ending point of an activity.
- E. Float: The measure of leeway in starting and completing an activity.
 - 1. Float time is not for the exclusive use or benefit of either Owner or Contractor, but is a jointly owned, expiring Project resource available to both parties as needed to meet schedule milestones and Contract completion date.
 - 2. Free float is the amount of time an activity can be delayed without adversely affecting the early start of the following activity.
 - 3. Total float is the measure of leeway in starting or completing an activity without adversely affecting the planned Project completion date.

- F. Fragnet: A partial or fragmentary network that breaks down activities into smaller activities for greater detail.
- G. Major Area: A story of construction, a separate building, or a similar significant construction element.
- H. Milestone: A key or critical point in time for reference or measurement.

1.04 SUBMITTALS

- A. Qualification Data: For firms and persons specified in “Quality Assurance” Article to demonstrate their capabilities and experience. Include lists of completed projects with project names and addresses, names and addresses of architects and owners, and other information specified.
- B. Submittals Schedule: Submit three copies of schedule. Arrange the following information in a tabular format:
 - 1. Scheduled date for first submittal.
 - 2. Specification Section number and title.
 - 3. Submittal category (action or informational).
 - 4. Name of subcontractor.
 - 5. Description of the Work covered.
 - 6. Scheduled date for final release or approval.
- C. Preliminary Construction Schedule: Submit two printed copies; one a single sheet of reproducible media, and one a print.
- D. Contractor's Construction Schedule: Submit two printed copies of initial schedule, one a reproducible print and one a blue- or black-line print, large enough to show entire schedule for entire construction period.

1.05 QUALITY ASSURANCE

- A. Prescheduling Conference: Conduct conference at Project site to comply with requirements in Division 1 Section “Project Management and Coordination.” Review methods and procedures related to the Preliminary Construction Schedule and Contractor's Construction Schedule, including, but not limited to, the following:
 - 1. Review software limitations and content and format for reports.
 - 2. Verify availability of qualified personnel needed to develop and update schedule.
 - 3. Discuss constraints, including phasing, work stages, area separations, interim milestones, and partial Owner occupancy.
 - 4. Review delivery dates for Owner-furnished products.
 - 5. Review schedule for work of Owner's separate contracts.
 - 6. Review time required for review of submittals and resubmittals.
 - 7. Review requirements for tests and inspections by independent testing and inspecting agencies.
 - 8. Review time required for completion and startup procedures.
 - 9. Review and finalize list of construction activities to be included in schedule.
 - 10. Review submittal requirements and procedures.
 - 11. Review procedures for updating schedule.

1.06 COORDINATION

- A. Coordinate preparation and processing of schedules and reports with performance of construction activities and with scheduling and reporting of separate contractors.
- B. Coordinate Contractor's Construction Schedule with the Schedule of Values, list of subcontracts, Submittals Schedule, progress reports, payment requests, and other required schedules and reports.
 - 1. Secure time commitments for performing critical elements of the Work from parties involved.
 - 2. Coordinate each construction activity in the network with other activities and schedule them in proper sequence.

PART 2 - PRODUCTS

2.01 SUBMITTALS SCHEDULE

- A. Preparation: Submit a schedule of submittals, arranged in chronological order by dates required by construction schedule. Include time required for review, resubmittal, ordering, manufacturing, fabrication, and delivery when establishing dates.
 - 1. Coordinate Submittals Schedule with list of subcontracts, the Schedule of Values, and Contractor's Construction Schedule.
 - 2. Initial Submittal: Submit concurrently with preliminary bar-chart schedule. Include submittals required during the first 60 days of construction. List those required to maintain orderly progress of the Work and those required early because of long lead time for manufacture or fabrication.
 - a. At Contractor's option, show submittals on the Preliminary Construction Schedule, instead of tabulating them separately.
 - 3. Final Submittal: Submit concurrently with the first complete submittal of Contractor's Construction Schedule.

2.02 CONTRACTOR'S CONSTRUCTION SCHEDULE, GENERAL

- A. Procedures: Comply with procedures contained in AGC's "Construction Planning & Scheduling."
- B. Time Frame: Extend schedule from date established for the Notice to Proceed to date of Substantial Completion and Final Completion.
 - 1. Contract completion date shall not be changed by submission of a schedule that shows an early completion date, unless specifically authorized by Change Order.
- C. Activities: Treat each story or separate area as a separate numbered activity for each principal element of the Work. Comply with the following:
 - 1. Activity Duration: Define activities so no activity is longer than 20 days, unless specifically allowed by Owner.
 - 2. Procurement Activities: Include procurement process activities for long lead items and major items, requiring a cycle of more than 60 days, as separate activities in schedule. Procurement cycle activities include, but are not limited to, submittals, approvals, purchasing, fabrication, and delivery.
 - 3. Submittal Review Time: Include review and resubmittal times indicated in Division 1 Section "Submittal Procedures" in schedule. Coordinate submittal review times in Contractor's Construction Schedule with Submittals Schedule.
 - 4. Startup and Testing Time: Include not less than 5 days for startup and testing.

5. Substantial Completion: Indicate completion in advance of date established for Substantial Completion, and allow time for administrative procedures necessary for certification of Substantial Completion.
- D. Constraints: Include constraints and work restrictions indicated in the Contract Documents and as follows in schedule, and show how the sequence of the Work is affected.
1. Owner-Furnished Products: Include a separate activity for each product. Include delivery date indicated in Division 1 Section "Summary." Delivery dates indicated stipulate the earliest possible delivery date.
 2. Work Restrictions: Show the effect of the following items on the schedule:
 - a. Coordination with existing construction.
 - b. Limitations of continued occupancies.
 - c. Uninterruptible services.
 - d. Partial occupancy before Substantial Completion.
 - e. Use of premises restrictions.
 - f. Provisions for future construction.
 - g. Seasonal variations.
 - h. Environmental control.
 3. Area Separations: Identify each major area of construction for each major portion of the Work. Indicate where each construction activity within a major area must be sequenced or integrated with other construction activities to provide for the following:
 - a. Structural completion.
 - b. Permanent space enclosure.
 - c. Completion of mechanical installation.
 - d. Completion of electrical installation.
 - e. Substantial Completion.
- E. Milestones: Include milestones indicated in the Contract Documents in schedule, including, but not limited to, the Notice to Proceed, interim milestones indicated below, Substantial Completion, and Final Completion.
- F. Contract Modifications: For each proposed contract modification and concurrent with its submission, prepare a time-impact analysis using fragnets to demonstrate the effect of the proposed change on the overall project schedule.
- G. Computer Software:
1. Prepare schedules using a program that has been developed specifically to manage construction schedules.
 2. Microsoft Projects 98, for Windows 95, Windows 98, Windows NT, Window 2000, or Windows XP operating system.

2.03 CONTRACTOR'S CONSTRUCTION SCHEDULE (GANTT CHART)

- A. Gantt-Chart Schedule: Submit a comprehensive, fully developed, horizontal Gantt-chart-type, Contractor's Construction Schedule within 20 days of date established for the Notice to Proceed. Base schedule on the Preliminary Construction Schedule and whatever updating and feedback was received since the start of Project.
- B. Preparation:

1. Indicate each significant construction activity separately. Identify first workday of each week with a continuous vertical line.
2. For construction activities that require 3 months or longer to complete, indicate an estimated completion percentage in 10 percent increments within time bar.

PART 3 - EXECUTION

3.01 CONTRACTOR'S CONSTRUCTION SCHEDULE

- A. Contractor's Construction Schedule Updating: At monthly intervals, update schedule to reflect actual construction progress and activities. Issue schedule one week before each regularly scheduled progress meeting.
 1. Revise schedule immediately after each meeting or other activity where revisions have been recognized or made. Issue updated schedule concurrently with the report of each such meeting.
 2. Include a report with updated schedule that indicates every change, including, but not limited to, changes in logic, durations, actual starts and finishes, and activity durations.
 3. As the Work progresses, indicate Actual Completion percentage for each activity.
- B. Distribution: Distribute copies of approved schedule to Owner, testing and inspecting agencies, and other parties identified by Contractor with a need-to-know schedule responsibility.
 1. Post copies in Project meeting rooms and temporary field offices.
 2. When revisions are made, distribute updated schedules to the same parties and post in the same locations. Delete parties from distribution when they have completed their assigned portion of the Work and are no longer involved in performance of construction activities.

END OF SECTION

SECTION 01360 – REQUEST FOR INFORMATION

PART 1 - GENERAL

1.01 RELATED DOCUMENTS

- A. Drawings and general provisions of the Contract, including General and Supplementary Conditions and other Division 1 Specification Sections, apply to this Section.

1.02 SUMMARY

- A. Section includes administrative and procedural requirements governing Request for Interpretation.
- B. Related Sections include:
 - 1. Division 1 Section “Submittal Procedure” for procedure for submitting Action and Information Submittals.
 - 2. Division 1 Section “Contract Modifications Procedures” for procedural requirements for implementing changes in the Work.
 - 3. Division 1 Section “Quality Requirements” for quality-assurance and quality control requirements and for submitting test and inspection reports.
 - 4. Division 1 Section “Product Requirements” for administrative and procedural requirements for material and equipment product selection and handling, warranties, and product substitution.
 - 5. Division 1 Section “Product Requirements” for administrative procedures for handling requests for substitutions made after Contract Documents.

1.03 DEFINITIONS

- A. Request for Interpretation:
 - 1. A written request from the Contractor to the Architect seeking an interpretation or clarification of some requirement of the Contract Documents.
 - 2. The following are not Requests for Interpretation:
 - a. Substitution Request.
 - b. Non-Conformance Notice.
 - c. Action Submittals.
 - d. Information Submittals.
 - e. Shop Drawings, Product Data, and Samples required by the Contract Documents.
 - f. Schedule Submittals.
 - g. Project Memos and Letters.
- B. Drawing/Specification Clarification: A response from the Architect, in response to an inquiry from the Contractor, intended to make some requirement of the drawings or specifications more clearly understood. Drawings/Specification clarification may be sketches, drawings, or in narrative form and will not change any requirements of the Drawings or Specifications.

1.04 REQUEST FOR INTERPRETATION

- A. In the event the Contract Documents require clarification or interpretation, submit a “Request for Interpretation” in writing to the Architect using one of the following:

1. Form provided by the Architect (Section 01361 "Request for Interpretation Form).
 2. AIA G716 "Request for Interpretation."
 3. CSI Form 13.2A "Request for Interpretation."
 4. Contractor's form to which the Architect has no objection.
- B. Clearly and concisely state the issue for which clarification or interpretation is required and why a response from the Architect is needed.
1. State interpretation or understanding of the Contract Document's requirements along with reasons for reaching the understanding.
 2. Response from the Architect will not change requirements of the Contract Documents.
- C. The Architect will review Requests for Interpretation to determine if they are valid within the meaning of the term. If the Architect determines the document is not a Request for Interpretation, he will return the document to the Contractor for resubmission in the proper form.
- D. Responses to Request for Interpretation will be issued within the 5 days of receipt of the request from the Contractor unless the Architect determines that a longer time is necessary to provide an adequate response.
1. If a longer time is determined necessary, the Architect will notify the Contractor within the 5 days of the anticipated response time.
 2. If the Contractor submits a Request for Interpretation on an activity with 5 days or less float on the current Project Schedule, the Contractor shall not be entitled to any time extension due to the time it takes the Architect to respond to the request, provided that the Architect responds within the 5 days set forth above.
- E. A Drawing/Specification Clarification issued by the Architect does not constitute a change to any requirement of the Contract Documents.
1. If the Contractor believes that a Drawing/Specification Clarification to a Request for Interpretation will cause a change to the requirements of the Contract Document, the Contractor shall immediately give written notice to the Architect stating that the Contractor considers the response to be a modification to the Contract.
 2. Failure on the part of the Contractor to give such written notice immediately shall waive Contractor's right to seek additional time or cost under Division 1 Section "Contract Modifications Procedures."
- F. Where a response to a Request for Clarification constitutes a modification to contract requirements, the Architect will follow administrative procedures under Division 1 Section "Contract Modifications Procedures."

END OF SECTION

REQUEST FOR INFORMATION FORM

RFI NO.:

PROJECT:

PROJECT NO.:

TO: **Boucher Design Group LLC**
Architect

FROM: _____
Contractor

Contractor requests clarification or interpretation of the following contract document condition as an RFI following requirements of Division 1 Section "Request For Interpretation":

General Description:

Drawing/Detail No. _____

Specification Section No.: _____ Paragraph No.: _____

We request information or clarification because:

A response from the Architect is required because:

Our interpretation or understanding of the requirements of the Contract Documents is:

We base our understanding on:

By: _____
Contractor

Signature

Date

ARCHITECT'S REVIEW AND ACTION:

_____ Your interpretation of the Contract Documents is correct.

_____ This document is not an RFI and therefore is being returned without a response. This document has not been entered into the Project's RFI Log. This is a _____ . Please resubmit the document on the proper form for timely processing.

_____ This RFI will require more than five (5) days to respond to and will be answered by _____ .

Architect's clarification:

Architect's Signature

Date

SECTION 01400 - QUALITY REQUIREMENTS

PART 1 - GENERAL

1.01 RELATED DOCUMENTS

- A. Drawings and general provisions of the Contract, including General and Supplementary Conditions and other Division 1 Specification Sections, apply to this Section.

1.02 SUMMARY

- A. Section includes administrative and procedural requirements for quality assurance and quality control.
- B. Testing and inspecting services are required to verify compliance with requirements specified or indicated. These services do not relieve Contractor of responsibility for compliance with the Contract Document requirements.
 - 1. Specific quality-control requirements for individual construction activities are specified in the Sections that specify those activities. Requirements in those Sections may also cover production of standard products.
 - 2. Specified tests, inspections, and related actions do not limit Contractor's quality-control procedures that facilitate compliance with the Contract Document requirements.
 - 3. Requirements for Contractor to provide quality-control services required by Architect, Owner, or authorities having jurisdiction are not limited by provisions of this Section.
- C. Related Sections include:
 - 1. Division 1 Section "Allowances" for testing and inspecting allowances.
 - 2. Division 1 Section "Construction Progress Documentation" for developing a schedule of required tests and inspections.
 - 3. Division 1 Section "Cutting and Patching" for repair and restoration of construction disturbed by testing and inspecting activities.
 - 4. Divisions 2 through 14 Sections for specific test and inspection requirements.

1.03 DEFINITIONS

- A. Quality-Assurance Services: Activities, actions, and procedures performed before and during execution of the Work to guard against defects and deficiencies and ensure that proposed construction complies with requirements.
- B. Quality-Control Services: Tests, inspections, procedures, and related actions during and after execution of the Work to evaluate that completed construction complies with requirements. Services do not include contract enforcement activities performed by Architect.
- C. Mockups: Full-size, physical example assemblies to illustrate finishes and materials. Mockups are used to verify selections made under Sample submittals, to demonstrate aesthetic effects and, where indicated, qualities of materials and execution, and to review construction, coordination, testing, or operation; they are not Samples.
- D. Testing Agency: An entity engaged to perform specific tests, inspections, or both. Testing laboratory shall mean the same as testing agency.

1.04 DELEGATED DESIGN

- A. Where professional design services or certifications by a design professional are specifically required of Contractor by the Contract Documents, provide products and systems complying with specific performance and design criteria indicated.
 - 1. If criteria indicated are not sufficient to perform services or certification required, submit a written request for additional information to Architect.

1.05 SUBMITTALS

- A. Submit qualification data for testing agencies specified in "Quality Assurance" Article to demonstrate their capabilities and experience. Include proof of qualifications in the form of a recent report on the inspection of the testing agency by a recognized authority.
- B. In addition to Shop Drawings, Product Data, and other required submittals, submit a statement, signed and sealed by the responsible design professional, for each product and system specifically assigned to Contractor to be designed or certified by a design professional, indicating that the products and systems are in compliance with performance and design criteria indicated. Include list of codes, loads, and other factors used in performing these services.
- C. Submit schedule of tests and inspections. Prepare in tabular form and include the following:
 - 1. Specification Section number and title.
 - 2. Description of test and inspection.
 - 3. Identification of applicable standards.
 - 4. Identification of test and inspection methods.
 - 5. Number of tests and inspections required.
 - 6. Time schedule or time span for tests and inspections.
 - 7. Entity responsible for performing tests and inspections.
 - 8. Requirements for obtaining samples.
 - 9. Unique characteristics of each quality control service.

1.06 REQUIRED TESTING:

- A. Excavation, Site Fill and Grading:
 - 1. When fill is required, Soils Engineering firm shall document that the proposed fill material is acceptable and percentages of compaction are being maintained. Submit copies of test reports to the Architect for review. Do not proceed with building construction until written approval of the fill is given by the Architect.
- B. Soils Tests:
 - 1. Soil Analysis Method:
 - a. Liquid Limit.
 - b. Plastic Limit.
 - c. Plasticity Index.
 - d. Maximum Laboratory Density (Proctor) Tests.
 - 2. Number of Analysis: One for each type of soil used under structure or pavement.
 - 3. Field Density Tests: Not less than one set for each 10,000 square feet. Perform at least 3 tests per set.
- C. Concrete:

1. Aggregate Tests: Check the proposed aggregate in accordance with ASTM C33.
2. Mix Design: Check the proposed mixed for proportions, water-cement ratio and slump in accordance with ACI 613 and 318 and with PDA T-12.
3. Slump Tests: Take at the beginning of each day's pouring operations and when water adjustments or noticeable change of slump occurs, ASTM C 143.
4. Sampling: Take 4 standard cylinders at the beginning of each pour and 4 additional cylinders for additional 50 cubic yards or fraction thereof. Take extra samples at any noticeable change in the make-up of the concrete. Perform all sampling in compliance with ASTM C 172.
5. Testing: Cure cylinders in accordance with ASTM C 31. Test 2 cylinders at 7 days and 2 cylinders at 28 days (ATMC C 39). Average the results of the tests.

1.07 DOCUMENTATION

- A. Prepare and submit certified written reports that include the following:
 1. Date of issue.
 2. Project title and number.
 3. Name, address, and telephone number of testing agency.
 4. Dates and locations of samples and tests or inspections.
 5. Names of individuals making tests and inspections.
 6. Description of the Work and test and inspection method.
 7. Identification of product and Specification Section.
 8. Complete test or inspection data.
 9. Test and inspection results and an interpretation of test results.
 10. Ambient conditions at time of sample taking and testing and inspecting.
 11. Comments or professional opinion on whether tested or inspected Work complies with the Contract Document requirements.
 12. Name and signature of laboratory inspector.
 13. Recommendations on retesting and reinspecting.
- B. For Owner's records, submit copies of permits, licenses, certifications, inspection reports, releases, jurisdictional settlements, notices, receipts for fee payments, judgments, correspondence, records, and similar documents, established for compliance with standards and regulations bearing on performance of the Work.

1.08 QUALITY ASSURANCE

- A. Fabricator shall be a firm experienced in producing products similar to those indicated for this Project and with a record of successful in-service performance, as well as sufficient production capacity to produce required units.
- B. Factory-Authorized Service Representative shall be an authorized representative of manufacturer who is trained and approved by manufacturer to inspect installation of manufacturer's products that are similar in material, design, and extent to those indicated for this Project.
- C. Installer shall be a firm or individual experienced in installing, erecting, or assembling work similar in material, design, and extent to that indicated for this Project, whose work has resulted in construction with a record of successful in-service performance.

- D. Manufacturer shall be a firm experienced in manufacturing products or systems similar to those indicated for this Project and with a record of successful in-service performance.
- E. Professional Engineer shall be legally qualified to practice in jurisdiction where Project is located and who is experienced in providing engineering services of the kind indicated. Engineering services are defined as those performed for installations of the system, assembly, or product that are similar to those indicated for this Project in material, design, and extent.
- F. Certain sections of the Specifications require that specific construction activities shall be performed by entities who are recognized experts in those operations. Specialists shall satisfy qualification requirements indicated and shall be engaged for the activities indicated.
 - 1. Requirement for specialists shall not supersede building codes and similar regulations governing the Work, nor interfere with local trade-union jurisdictional settlements and similar conventions.
- G. Testing Agency shall be an agency with the experience and capability to conduct testing and inspecting indicated, as documented by ASTM E 548, and that specializes in types of tests and inspections to be performed.
- H. Testing agency shall perform preconstruction testing for compliance with specified requirements for performance and test methods.
 - 1. Contractor responsibilities include the following:
 - a. Provide test specimens and assemblies representative of proposed materials and construction. Provide sizes and configurations of assemblies to adequately demonstrate capability of product to comply with performance requirements.
 - b. Submit specimens in a timely manner with sufficient time for testing and analyzing results to prevent delaying the Work.
 - c. Fabricate and install test assemblies using installers who will perform the same tasks for Project.
 - d. When testing is complete, remove assemblies; do not reuse materials on Project.
 - 2. Testing Agency Responsibilities: Promptly issue a certified written report of each test, inspection, and similar quality-assurance service to Architect, Owner, Structural Engineer and Contractor. Interpret tests and inspections and state in each report whether tested and inspected work complies with or deviates from the Contract Documents.
- I. Before installing portions of the Work requiring mockups, build mockups required to comply with the following requirements, using materials indicated for the completed Work:
 - 1. Construct integrated mockup composed of exterior finishes and materials and constructed to conform to indicated details. Mockup drawing indicates
 - a. Materials and material finishes to be included.
 - b. Sizes of material/finish components.
 - 2. Mockup size shall be as indicated on the Drawings, but not more than 10 feet by 10 feet.

3. Conform to the details on the Drawings for construction. Demonstrate the proposed range of aesthetic effects and workmanship.
4. Notify Architect seven days in advance of dates and times when mockups will be constructed.
5. Demonstrate the proposed range of aesthetic effects and workmanship.
6. Obtain Architect's approval of mockups before starting work, fabrication, or construction. Architect's approval will be for quality will be for quality of workmanship, material finish, and detailed integration of materials.
7. Maintain mockups during construction in an undisturbed condition as a standard for judging the completed Work.
8. Demolish and remove mockups when directed, unless otherwise indicated.

1.09 QUALITY CONTROL

- A. Owner will engage a qualified testing agency to perform some of these services.
 1. Owner will furnish Contractor with names, addresses, and telephone numbers of testing agencies engaged and a description of the types of testing and inspecting they are engaged to perform.
 2. Payment for these services will be made from testing and inspecting allowances, as authorized by Change Orders.
 3. Costs for retesting and reinspecting construction that replaces or is necessitated by work that failed to comply with the Contract Documents will be charged to Contractor.
- B. Contractor Responsibilities: Unless otherwise indicated, provide quality-control services specified and required by authorities having jurisdiction.
 1. Where services are indicated as Contractor's responsibility, engage a qualified testing agency to perform these quality-control services.
 - a. Contractor shall not employ the same entity engaged by Owner.
 2. Notify testing agencies at least 24 hours in advance of time when Work that requires testing or inspecting will be performed.
 3. Where quality-control services are indicated as Contractor's responsibility, submit a certified written report, in duplicate, of each quality-control service.
 4. Testing and inspecting requested by Contractor and not required by the Contract Documents are Contractor's responsibility.
 5. Submit additional copies of each written report directly to authorities having jurisdiction, when they so direct.
 6. The absence of Owner Provided Testing Services during construction shall not relieve the Contractor from constructing the project in accordance with the Construction Documents. The Contractor shall be responsible for proving and payment of testing services necessary to assure this conformance.
- C. Owner will engage a testing agency to conduct special tests and inspections required by authorities having jurisdiction as the responsibility of Owner.
 1. Testing agency will notify Architect and Contractor promptly of irregularities and deficiencies observed in the Work during performance of its services.
 2. Testing agency will submit a certified written report of each test, inspection, and similar quality-control service to Architect with copy to Contractor and to authorities having jurisdiction.

3. Testing agency will submit a final report of special tests and inspections at Substantial Completion, which includes a list of unresolved deficiencies.
 4. Testing agency will interpret tests and inspections and state in each report whether tested and inspected work complies with or deviates from the Contract Documents.
 5. Testing agency will retest and reinspect corrected work.
- D. Where indicated, engage a factory-authorized service representative to inspect field-assembled components and equipment installation, including service connections. Report results in writing.
- E. Regardless of whether original tests or inspections were Contractor's responsibility, provide quality-control services, including retesting and reinspecting, for construction that revised or replaced Work that failed to comply with requirements established by the Contract Documents.
- F. Cooperate with Architect and Contractor in performance of duties. Provide qualified personnel to perform required tests and inspections.
1. Notify Architect and Contractor promptly of irregularities or deficiencies observed in the Work during performance of its services.
 2. Interpret tests and inspections and state in each report whether tested and inspected work complies with or deviates from requirements.
 3. Submit a certified written report, in duplicate, of each test, inspection, and similar quality-control service through Contractor.
 4. Do not release, revoke, alter, or increase requirements of the Contract Documents or approve or accept any portion of the Work.
 5. Do not perform any duties of Contractor.
- G. Cooperate with agencies performing required tests, inspections, and similar quality-control services, and provide reasonable auxiliary services as requested. Notify agency sufficiently in advance of operations to permit assignment of personnel. Provide the following:
1. Access to the Work.
 2. Incidental labor and facilities necessary to facilitate tests and inspections.
 3. Adequate quantities of representative samples of materials that require testing and inspecting. Assist agency in obtaining samples.
 4. Facilities for storage and field-curing of test samples.
 5. Preliminary design mix proposed for use for material mixes that require control by testing agency.
 6. Security and protection for samples and for testing and inspecting equipment at Project site.
- H. Coordinate sequence of activities to accommodate required quality-assurance and quality-control services with a minimum of delay and to avoid necessity of removing and replacing construction to accommodate testing and inspecting.
1. Schedule times for tests, inspections, obtaining samples, and similar activities.
- I. Prepare a schedule of tests, inspections, and similar quality-control services required by the Contract Documents. Submit schedule within 14 days of date established for commencement of the Work.

1. Distribution: Distribute schedule to Owner, Architect, testing agencies, and each party involved in performance of portions of the Work where tests and inspections are required.

PART 2 - EXECUTION

2.01 REPAIR AND PROTECTION

- A. On completion of testing, inspecting, sample taking, and similar services, repair damaged construction and restore substrates and finishes.
 1. Provide materials and comply with installation requirements specified in other Sections of these Specifications. Restore patched areas and extend restoration into adjoining areas in a manner that eliminates evidence of patching.
 2. Comply with the Contract Document requirements for Division 1 Section "Cutting and Patching."
- B. Protect construction exposed by or for quality-control service activities.
- C. Repair and protection are Contractor's responsibility, regardless of the assignment of responsibility for quality-control services.

END OF SECTION

SECTION 01421 – REFERENCES

PART 1 - GENERAL

1.01 RELATED DOCUMENTS

- A. Drawings and general provisions of the Contract, including General and Supplementary Conditions and other Division 1 Specification Sections, apply to this Section.

1.02 DEFINITIONS

- A. General: Basic Contract definitions are included in the Conditions of the Contract.
- B. Unless otherwise indicated, the following definitions apply to this project:
 - 1. “Approved”: The term “approved,” when used to convey Architect's action on Contractor's submittals, applications, and requests, is limited to Architect's duties and responsibilities as stated in the Conditions of the Contract.
 - 2. “Directed”: Terms such as “directed,” “requested,” “authorized,” “selected,” “approved,” “required,” and “permitted” mean directed by Architect, requested by Architect, and similar phrases.
 - 3. “Indicated”: The term “indicated” refers to graphic representations, notes, or schedules on Drawings or to other paragraphs or schedules in Specifications and similar requirements in the Contract Documents. Terms such as “shown,” “noted,” “scheduled,” and “specified” are used to help the user locate the reference.
 - 4. “Regulations”: The term “regulations” includes laws, ordinances, statutes, and lawful orders issued by authorities having jurisdiction, as well as rules, conventions, and agreements within the construction industry that control performance of the Work.
 - 5. “Furnish”: The term “furnish” means to supply and deliver to Project site, ready for unloading, unpacking, assembly, installation, and similar operations.
 - 6. “Install”: The term “install” describes operations at Project site including unloading, temporarily storing, unpacking, assembling, erecting, placing, anchoring, applying, working to dimension, finishing, curing, protecting, cleaning, and similar operations.
 - 7. “Provide”: The term “provide” means to furnish and install, complete and ready for the intended use.
 - 8. “Installer”: An installer is the Contractor or another entity engaged by Contractor as an employee, Subcontractor, or Sub-subcontractor, to perform a particular construction operation, including installation, erection, application, and similar operations.
 - 9. The term “experienced,” when used with an entity, means having successfully completed a minimum of 3 previous projects similar in size and scope to this Project; being familiar with special requirements indicated; and having complied with requirements of authorities having jurisdiction.
 - a. Using a term such as “carpentry” does not imply that certain construction activities must be performed by accredited or unionized individuals of a corresponding generic name, such as “carpenter.” It also does not imply that requirements specified apply exclusively to tradespeople of the corresponding generic name.

1.03 INDUSTRY STANDARDS

- A. Applicability of Standards: Unless the Contract Documents include more stringent requirements, applicable construction industry standards have the same force and effect as if

bound or copied directly into the Contract Documents to the extent referenced. Such standards are made a part of the Contract Documents by reference.

- B. Publication Dates: Comply with standards in effect as of date of the Contract Documents, unless otherwise indicated.
- C. Conflicting Requirements:
 - 1. If compliance with two or more standards is specified and the standards establish different or conflicting requirements for minimum quantities or quality levels, comply with the most stringent requirement. Refer uncertainties and requirements that are different, but apparently equal, to Architect for a decision before proceeding.
 - 2. Minimum Quantity or Quality Levels: The quantity or quality level shown or specified shall be the minimum provided or performed. The actual installation may comply exactly with the minimum quantity or quality specified, or it may exceed the minimum within reasonable limits. To comply with these requirements, indicated numeric values are minimum or maximum, as appropriate, for the context of requirements. Refer uncertainties to Architect for a decision before proceeding.
- D. Copies of Standards:
 - 1. Each entity engaged in construction on Project must be familiar with industry standards applicable to its construction activity. Copies of applicable standards are not bound with the Contract Documents.
 - 2. Where copies of standards are needed to perform a required construction activity, obtain copies directly from publication source and make them available on request.
- E. Abbreviations and Acronyms: Where abbreviations and acronyms are used in Specifications or other Contract Documents, they shall mean the name of entities generally recognized in the construction industry. The Architect will make a complete list available by the to the Contractor upon written request. Types of entities include:
 - 1. Industry Organizations.
 - 2. Code Agencies.
 - 3. Federal Government Agencies.
 - 4. State Government Agencies.

END OF SECTION

SECTION 01600 - PRODUCT REQUIREMENTS

PART 1 - GENERAL

1.01 RELATED DOCUMENTS

- A. Drawings and general provisions of the Contract, including General and Supplementary Conditions and other Division 1 Specification Sections, apply to this Section.

1.02 SUMMARY

- A. Section includes the following administrative and procedural requirements:
 - 1. Selection of products for use in Project.
 - 2. Delivery, storage, and handling.
 - 3. Manufacturers' standard warranties on products and special warranties.
 - 4. Product options, substitutions, and comparable products.
- B. Related Sections include:
 - 1. Division 1 Section "Alternates" for products selected under an alternate.
 - 2. Division 1 Section "References" for applicable industry standards for products specified.
 - 3. Division 1 Section "Closeout Procedures" for submitting warranties for contract closeout.
 - 4. Divisions 2 through 16 Sections for specific requirements for warranties on products and installations specified to be warranted.

1.03 DEFINITIONS

- A. Products: Items purchased for incorporating into the Work, whether purchased for Project or taken from previously purchased stock. The term "product" includes the terms "material," "equipment," "system," and terms of similar intent.
 - 1. Named Products: Items identified by manufacturer's product name, including make or model number or other designation, shown or listed in manufacturer's published product literature, that is current as of date of the Contract Documents.
 - 2. New Products: Items that have not previously been incorporated into another project or facility, except that products consisting of recycled-content materials are allowed, unless explicitly stated otherwise. Products salvaged or recycled from other projects are not considered new products.
 - 3. Comparable Product: Product that is demonstrated and approved through submittal process, or where indicated as a product substitution, to have the indicated qualities related to type, function, dimension, in-service performance, physical properties, appearance, and other characteristics that equal or exceed those of specified product.
- B. Substitutions: Changes in products, materials, equipment, and methods of construction from those required by the Contract Documents and proposed by Contractor.
- C. Basis-of-Design Product Specification: Where a specific manufacturer's product is named and accompanied by the words "basis of design," including make or model number or other designation, to establish the significant qualities related to type, function, dimension, in-service performance, physical properties, appearance, and other characteristics for purposes of evaluating comparable products of other named manufacturers.

- D. Manufacturer's Warranty: Preprinted written warranty published by individual manufacturer for a particular product and specifically endorsed by manufacturer to Owner.
- E. Special Warranty: Written warranty required by or incorporated into the Contract Documents, either to extend time limit provided by manufacturer's warranty or to provide more rights for Owner.

1.04 SUBMITTALS

- A. Substitution Requests: Submit three copies of each request for consideration. Identify product or fabrication or installation method to be replaced. Include Specification Section number and title and Drawing numbers and titles.
 - 1. Substitution Request Form: Use CSI Form 13.1A. Sample form provided at end of Section.
 - 2. Documentation: Show compliance with requirements for substitutions and the following, as applicable:
 - a. Statement indicating why specified material or product cannot be provided.
 - b. Coordination information, including a list of changes or modifications needed to other parts of the Work and to construction performed by Owner and separate contractors, that will be necessary to accommodate proposed substitution.
 - c. Detailed comparison of significant qualities of proposed substitution with those of the Work specified. Significant qualities may include attributes such as performance, weight, size, durability, visual effect, and specific features and requirements indicated.
 - d. Product Data, including drawings and descriptions of products and fabrication and installation procedures.
 - e. Samples, where applicable or requested.
 - f. List of similar installations for completed projects with project names and addresses and names and addresses of architects and owners.
 - g. Material test reports from a qualified testing agency indicating and interpreting test results for compliance with requirements indicated.
 - h. Research/evaluation reports evidencing compliance with building code in effect for Project, from a model code organization acceptable to authorities having jurisdiction.
 - i. Detailed comparison of Contractor's Construction Schedule using proposed substitution with products specified for the Work, including effect on the overall Contract Time. If specified product or method of construction cannot be provided within the Contract Time, include letter from manufacturer, on manufacturer's letterhead, stating lack of availability or delays in delivery.
 - j. Cost information, including a proposal of change, if any, in the Contract Sum.
 - k. Contractor's certification that proposed substitution complies with requirements in the Contract Documents and is appropriate for applications indicated.
 - l. Contractor's waiver of rights to additional payment or time that may subsequently become necessary because of failure of proposed substitution to produce indicated results.
 - 3. Architect's Action: If necessary, Architect will request additional information or documentation for evaluation within one week of receipt of a request for substitution. Architect will notify Contractor of acceptance or rejection of proposed substitution within 15 days of receipt of request, or 7 days of receipt of additional information or documentation, whichever is later.
 - a. Form of Acceptance: Change Order.

- b. Use product specified if Architect cannot make a decision on use of a proposed substitution within time allocated.
- B. Product List: Submit a list, in tabular form, showing specified products. Include generic names of products required. Include manufacturer's name and proprietary product names for each product.
 - 1. Coordinate product list with Contractor's Construction Schedule and the Submittals Schedule.
 - 2. Form: Tabulate information for each product under the following column headings:
 - a. Specification Section number and title.
 - b. Generic name used in the Contract Documents.
 - c. Proprietary name, model number, and similar designations.
 - d. Manufacturer's name and address.
 - e. Supplier's name and address.
 - f. Installer's name and address.
 - g. Projected delivery date or time span of delivery period.
 - h. Identification of items that require early submittal approval for scheduled delivery date.
 - 3. Completed List: Within 60 days after date of commencement of the Work, submit 3 copies of completed product list. Include a written explanation for omissions of data and for variations from Contract requirements.
 - 4. Architect's Action: Architect will respond in writing to Contractor within 15 days of receipt of completed product list. Architect's response will include a list of unacceptable product selections and a brief explanation of reasons for this action. Architect's response, or lack of response, does not constitute a waiver of requirement that products comply with the Contract Documents.
- C. Basis-of-Design Product Specification Submittal: Comply with requirements in Division 1 Section "Submittal Procedures." Show compliance with requirements.

1.05 QUALITY ASSURANCE

- A. Compatibility of Options: If Contractor is given option of selecting between two or more products for use on Project, product selected shall be compatible with products previously selected, even if previously selected products were also options.

1.06 PRODUCT DELIVERY, STORAGE, AND HANDLING

- A. Deliver, store, and handle products using means and methods that will prevent damage, deterioration, and loss, including theft. Comply with manufacturer's written instructions.
 - 1. Schedule delivery to minimize long-term storage at Project site and to prevent overcrowding of construction spaces.
 - 2. Coordinate delivery with installation time to ensure minimum holding time for items that are flammable, hazardous, easily damaged, or sensitive to deterioration, theft, and other losses.
 - 3. Deliver products to Project site in an undamaged condition in manufacturer's original sealed container or other packaging system, complete with labels and instructions for handling, storing, unpacking, protecting, and installing.
 - 4. Inspect products on delivery to ensure compliance with the Contract Documents and to ensure that products are undamaged and properly protected.
 - 5. Store products to allow for inspection and measurement of quantity or counting of units.

6. Store materials in a manner that will not endanger Project structure.
 7. Store products that are subject to damage by the elements, under cover in a weathertight enclosure above ground, with ventilation adequate to prevent condensation.
 8. Comply with product manufacturer's written instructions for temperature, humidity, ventilation, and weather-protection requirements for storage.
 9. Protect stored products from damage.
- B. Storage: Provide a secure location and enclosure at Project site for storage of materials and equipment by Owner's construction forces. Coordinate location with Owner.

1.07 PRODUCT WARRANTIES

- A. Warranties specified in other Sections shall be in addition to, and run concurrent with, other warranties required by the Contract Documents. Manufacturer's disclaimers and limitations on product warranties do not relieve Contractor of obligations under requirements of the Contract Documents.
- B. Special Warranties: Prepare a written document that contains appropriate terms and identification, ready for execution. Submit a draft for approval before final execution.
1. Manufacturer's Standard Form: Modified to include Project-specific information and properly executed.
 2. Specified Form: Forms are included with the Specifications. Prepare a written document using appropriate form properly executed.
 3. Refer to Divisions 2 through 16 Sections for specific content requirements and particular requirements for submitting special warranties.
- C. Submittal Time: Comply with requirements in Division 1 Section "Closeout Procedures."

PART 2 - PRODUCTS

2.01 PRODUCT OPTIONS

- A. General Product Requirements: Provide products that comply with the Contract Documents, that are undamaged, and unless otherwise indicated, that are new at time of installation.
1. Provide products complete with accessories, trim, finish, fasteners, and other items needed for a complete installation and indicated use and effect.
 2. Standard Products: If available, and unless custom products or nonstandard options are specified, provide standard products of types that have been produced and used successfully in similar situations on other projects.
 3. Owner reserves the right to limit selection to products with warranties not in conflict with requirements of the Contract Documents.
 4. Where products are accompanied by the term "as selected," Architect will make selection.
 5. Where products are accompanied by the term "match sample," sample to be matched is Architect's.
 6. Descriptive, performance, and reference standard requirements in the Specifications establish "salient characteristics" of products.
 7. Or Equal: Where products are specified by name and accompanied by the term "or equal" or "or approved equal" or "or approved," comply with provisions in "Comparable Products" Article to obtain approval for use of an unnamed product.
- B. Product Selection Procedures: Procedures for product selection include the following:
1. Product:

- a. Where Specification paragraphs or subparagraphs titled “Product” name a single product and manufacturer, provide the product named.
 - b. Substitutions may be considered, unless otherwise indicated.
2. Manufacturer/Source:
 - a. Where Specification paragraphs or subparagraphs titled “Manufacturer” or “Source” name single manufacturers or sources, provide a product by the manufacturer or from the source named that complies with requirements.
 - b. Substitutions may be considered, unless otherwise indicated.
 3. Products:
 - a. Where Specification paragraphs or subparagraphs titled “Products” introduce a list of names of both products and manufacturers, provide one of the products listed that complies with requirements.
 - b. Substitutions may be considered, unless otherwise indicated.
 4. Manufacturers:
 - a. Where Specification paragraphs or subparagraphs titled “Manufacturers” introduce a list of manufacturers' names, provide a product by one of the manufacturers listed that complies with requirements.
 - b. Substitutions may be considered, unless otherwise indicated.
 5. Available Products: Where Specification paragraphs or subparagraphs titled “Available Products” introduce a list of names of both products and manufacturers, provide one of the products listed or another product that complies with requirements. Comply with provisions in “Comparable Products” Article to obtain approval for use of an unnamed product.
 6. Available Manufacturers: Where Specification paragraphs or subparagraphs titled “Available Manufacturers” introduce a list of manufacturers' names, provide a product by one of the manufacturers listed or another manufacturer that complies with requirements. Comply with provisions in “Comparable Products” Article to obtain approval for use of an unnamed product.
 7. Product Options: Where Specification paragraphs titled “Product Options” indicate that size, profiles, and dimensional requirements on Drawings are based on a specific product or system, provide either the specific product or system indicated or a comparable product or system by another manufacturer. Comply with provisions in “Product Substitutions” Article.
 8. Basis-of-Design Products:
 - a. Where Specification paragraphs or subparagraphs titled “Basis-of-Design Product[s]” are included and also introduce or refer to a list of manufacturers' names, provide either the specified product or a comparable product by one of the other named manufacturers. Drawings and Specifications indicate sizes, profiles, dimensions, and other characteristics that are based on the product named. Comply with provisions in “Comparable Products” Article to obtain approval for use of an unnamed product.
 - b. Substitutions may be considered, unless otherwise indicated.
 9. Visual Matching Specification:
 - a. Where Specifications require matching an established Sample, select a product (and manufacturer) that complies with requirements and matches Architect's sample. Architect's decision will be final on whether a proposed product matches satisfactorily.

- b. If no product available within specified category matches satisfactorily and complies with other specified requirements, comply with provisions of the Contract Documents on “substitutions” for selection of a matching product.
10. Visual Selection Specification:
- a. Where Specifications include the phrase “as selected from manufacturer's colors, patterns, textures” or a similar phrase, select a product (and manufacturer) that complies with other specified requirements.
 - b. Standard Range: Where Specifications include the phrase “standard range of colors, patterns, textures” or similar phrase, Architect will select color, pattern, or texture from manufacturer's product line that does not include premium items.
 - c. Full Range: Where Specifications include the phrase “full range of colors, patterns, textures” or similar phrase, Architect will select color, pattern, or texture from manufacturer's product line that includes both standard and premium items.

2.02 PRODUCT SUBSTITUTIONS

- A. Timing: Architect will consider requests for substitution if received within 15 days after the Notice to Proceed. Requests received after that time may be considered or rejected at discretion of Architect.
- B. Conditions: Architect will consider Contractor's request for substitution when the following conditions are satisfied. If the following conditions are not satisfied, Architect will return requests without action, except to record noncompliance with these requirements:
 - 1. Requested substitution offers Owner a substantial advantage in cost, time, energy conservation, or other considerations, after deducting additional responsibilities Owner must assume. Owner's additional responsibilities may include compensation to Architect for redesign and evaluation services, increased cost of other construction by Owner, and similar considerations.
 - 2. Requested substitution does not require extensive revisions to the Contract Documents.
 - 3. Requested substitution is consistent with the Contract Documents and will produce indicated results.
 - 4. Substitution request is fully documented and properly submitted.
 - 5. Requested substitution will not adversely affect Contractor's Construction Schedule.
 - 6. Requested substitution has received necessary approvals of authorities having jurisdiction.
 - 7. Requested substitution is compatible with other portions of the Work.
 - 8. Requested substitution has been coordinated with other portions of the Work.
 - 9. Requested substitution provides specified warranty.
 - 10. If requested substitution involves more than one contractor, requested substitution has been coordinated with other portions of the Work, is uniform and consistent, is compatible with other products, and is acceptable to all contractors involved.

2.03 COMPARABLE PRODUCTS

- A. Where products or manufacturers are specified by name, submit the following, in addition to other required submittals, to obtain approval of an unnamed product:
 - 1. Evidence that the proposed product does not require extensive revisions to the Contract Documents, that it is consistent with the Contract Documents and will produce the indicated results, and that it is compatible with other portions of the Work.

2. Detailed comparison of significant qualities of proposed product with those named in the Specifications. Significant qualities include attributes such as performance, weight, size, durability, visual effect, and specific features and requirements indicated.
3. Evidence that proposed product provides specified warranty.
4. List of similar installations for completed projects with project names and addresses and names and addresses of architects and owners, if requested.
5. Samples, if requested.

END OF SECTION

SECTION 01700 - EXECUTION REQUIREMENTS

PART 1 - GENERAL

1.01 RELATED DOCUMENTS

- A. Drawings and general provisions of the Contract, including General and Supplementary Conditions and other Division 1 Specification Sections, apply to this Section.

1.02 SUMMARY

- A. Section includes general procedural requirements governing execution of the Work including, but not limited to, the following:
 - 1. Construction layout.
 - 2. Field engineering and surveying.
 - 3. General installation of products.
 - 4. Coordination of Owner-installed products.
 - 5. Progress cleaning.
 - 6. Starting and adjusting.
 - 7. Protection of installed construction.
 - 8. Correction of the Work.
- B. Related Sections include the following:
 - 1. Division 1 Section "Project Management and Coordination" for procedures for coordinating field engineering with other construction activities.
 - 2. Division 1 Section "Submittal Procedures" for submitting surveys.
 - 3. Division 1 Section "Closeout Procedures" for submitting final property survey with Project Record Documents, recording of Owner-accepted deviations from indicated lines and levels, and final cleaning.

1.03 SUBMITTALS

- A. Qualification Data: For land surveyor or professional engineer to demonstrate their capabilities and experience. Include lists of completed projects with project names and addresses, names and addresses of architects and owners, and other information specified.
- B. Certificates: Submit certificate signed by land surveyor or professional engineer certifying that location and elevation of improvements comply with requirements.
- C. Certified Surveys: Submit 2 copies signed by land surveyor or professional engineer.
- D. Final Property Survey: Submit 2 reproducible copies showing the Work performed and record survey data.

1.04 QUALITY ASSURANCE

- A. Land Surveyor Qualifications: A professional land surveyor who is legally qualified to practice in jurisdiction where Project is located and who is experienced in providing land-surveying services of the kind indicated.

PART 2 - EXECUTION

2.01 EXAMINATION

- A. Existing Utilities: The existence and location of underground and other utilities and construction indicated as existing are not guaranteed. Before beginning sitework, investigate and verify the existence and location of underground utilities and other construction affecting the Work.
 - 1. Before construction, verify the location and invert elevation at points of connection of sanitary sewer, storm sewer, and water-service piping; and underground electrical services.
 - 2. Furnish location data for work related to Project that must be performed by public utilities serving Project site.
- B. Acceptance of Conditions: Examine substrates, areas, and conditions, with Installer or Applicator present where indicated, for compliance with requirements for installation tolerances and other conditions affecting performance. Record observations.
 - 1. Written Report: Where a written report listing conditions detrimental to performance of the Work is required by other Sections, include the following:
 - a. Description of the Work.
 - b. List of detrimental conditions, including substrates.
 - c. List of unacceptable installation tolerances.
 - d. Recommended corrections.
 - 2. Verify compatibility with and suitability of substrates, including compatibility with existing finishes or primers.
 - 3. Examine roughing-in for mechanical and electrical systems to verify actual locations of connections before equipment and fixture installation.
 - 4. Examine walls, floors, and roofs for suitable conditions where products and systems are to be installed.
 - 5. Proceed with installation only after unsatisfactory conditions have been corrected. Proceeding with the Work indicates acceptance of surfaces and conditions.

2.02 PREPARATION

- A. Existing Utility Information: Furnish information to local utility Owner that is necessary to adjust, move, or relocate existing utility structures, utility poles, lines, services, or other utility appurtenances located in or affected by construction. Coordinate with authorities having jurisdiction.
- B. Existing Utility Interruptions: Do not interrupt utilities serving facilities occupied by Owner or others unless permitted under the following conditions and then only after arranging to provide temporary utility services according to requirements indicated:
 - 1. Notify Architect and Owner not less than (2) two days in advance of proposed utility interruptions.
 - 2. Do not proceed with utility interruptions without Owner's written permission.
- C. Field Measurements: Take field measurements as required to fit the Work properly. Recheck measurements before installing each product. Where portions of the Work are indicated to fit to other construction, verify dimensions of other construction by field measurements before fabrication. Coordinate fabrication schedule with construction progress to avoid delaying the Work.

- D. Space Requirements: Verify space requirements and dimensions of items shown diagrammatically on Drawings.
- E. Review of Contract Documents and Field Conditions: Immediately on discovery of the need for clarification of the Contract Documents, submit a request for information to Architect. Include a detailed description of problem encountered, together with recommendations for changing the Contract Documents.

2.03 CONSTRUCTION LAYOUT

- A. Verification: Before proceeding to lay out the Work, verify layout information shown on Drawings, in relation to the property survey and existing benchmarks. If discrepancies are discovered, notify Architect promptly.
- B. General: Engage a land surveyor or professional engineer to lay out the Work using accepted surveying practices.
 - 1. Establish benchmarks and control points to set lines and levels at each story of construction and elsewhere as needed to locate each element of Project.
 - 2. Establish dimensions within tolerances indicated. Do not scale Drawings to obtain required dimensions.
 - 3. Inform installers of lines and levels to which they must comply.
 - 4. Check the location, level and plumb, of every major element as the Work progresses.
 - 5. Notify Architect when deviations from required lines and levels exceed allowable tolerances.
 - 6. Close site surveys with an error of closure equal to or less than the standard established by authorities having jurisdiction.
- C. Site Improvements: Locate and lay out site improvements, including pavements, grading, fill and topsoil placement, utility slopes, and invert elevations.
- D. Building Lines and Levels: Locate and lay out control lines and levels for structures, building foundations, column grids, and floor levels, including those required for mechanical and electrical work. Transfer survey markings and elevations for use with control lines and levels. Level foundations and piers from two or more locations.
- E. Record Log: Maintain a log of layout control work. Record deviations from required lines and levels. Include beginning and ending dates and times of surveys, weather conditions, name and duty of each survey party member, and types of instruments and tapes used. Make the log available for reference by Architect.

2.04 FIELD ENGINEERING

- A. Identification: Owner will identify existing benchmarks, control points, and property corners.
- B. Reference Points: Locate existing permanent benchmarks, control points, and similar reference points before beginning the Work. Preserve and protect permanent benchmarks and control points during construction operations.
 - 1. Do not change or relocate existing benchmarks or control points without prior written approval of Architect. Report lost or destroyed permanent benchmarks or control points promptly. Report the need to relocate permanent benchmarks or control points to Architect before proceeding.
 - 2. Replace lost or destroyed permanent benchmarks and control points promptly. Base replacements on the original survey control points.

- C. Benchmarks: Establish and maintain a minimum of (2) two permanent benchmarks on Project site, referenced to data established by survey control points. Comply with authorities having jurisdiction for type and size of benchmark.
 - 1. Record benchmark locations, with horizontal and vertical data, on Project Record Documents.
 - 2. Where the actual location or elevation of layout points cannot be marked, provide temporary reference points sufficient to locate the Work.
 - 3. Remove temporary reference points when no longer needed. Restore marked construction to its original condition.
- D. Certified Survey: On completion of foundation walls, major site improvements, and other work requiring field-engineering services, prepare a certified survey showing dimensions, locations, angles, and elevations of construction and sitework.
- E. Final Property Survey: Prepare a final property survey showing significant features (real property) for Project. Include on the survey a certification, signed by land surveyor or professional engineer, that principal metes, bounds, lines, and levels of Project are accurately positioned as shown on the survey.
 - 1. Show boundary lines, monuments, streets, site improvements and utilities, existing improvements and significant vegetation, adjoining properties, acreage, grade contours, and the distance and bearing from a site corner to a legal point.
 - 2. Recording: At Substantial Completion, have the final property survey recorded by or with authorities having jurisdiction as the official "property survey."

2.05 INSTALLATION

- A. General: Locate the Work and components of the Work accurately, in correct alignment and elevation, as indicated.
 - 1. Make vertical work plumb and make horizontal work level.
 - 2. Where space is limited, install components to maximize space available for maintenance and ease of removal for replacement.
 - 3. Conceal pipes, ducts, and wiring in finished areas, unless otherwise indicated.
 - 4. Maintain minimum headroom clearance of 8 feet in spaces without a suspended ceiling.
- B. Comply with manufacturer's written instructions and recommendations for installing products in applications indicated.
- C. Install products at the time and under conditions that will ensure the best possible results. Maintain conditions required for product performance until Substantial Completion.
- D. Conduct construction operations so no part of the Work is subjected to damaging operations or loading in excess of that expected during normal conditions of occupancy.
- E. Tools and Equipment: Do not use tools or equipment that produce harmful noise levels.
- F. Anchors and Fasteners: Provide anchors and fasteners as required to anchor each component securely in place, accurately located and aligned with other portions of the Work.
 - 1. Mounting Heights: Where mounting heights are not indicated, mount components at heights directed by Architect.
 - 2. Allow for building movement, including thermal expansion and contraction.
- G. Joints: Make joints of uniform width. Where joint locations in exposed work are not indicated, arrange joints for the best visual effect. Fit exposed connections together to form hairline joints.

- H. Hazardous Materials: Use products, cleaners, and installation materials that are not considered hazardous.

2.06 PROGRESS CLEANING

- A. General: Clean Project site and work areas daily, including common areas. Coordinate progress cleaning for joint-use areas where more than one installer has worked. Enforce requirements strictly. Dispose of materials lawfully.
 - 1. Comply with requirements in NFPA 241 for removal of combustible waste materials and debris.
 - 2. Do not hold materials more than 7 days during normal weather or 3 days if the temperature is expected to rise above 80 deg F.
 - 3. Containerize hazardous and unsanitary waste materials separately from other waste. Mark containers appropriately and dispose of legally, according to regulations.
- B. Site: Maintain Project site free of waste materials and debris.
- C. Work Areas: Clean areas where work is in progress to the level of cleanliness necessary for proper execution of the Work.
 - 1. Remove liquid spills promptly.
 - 2. Where dust would impair proper execution of the Work, broom-clean or vacuum the entire work area, as appropriate.
- D. Installed Work: Keep installed work clean. Clean installed surfaces according to written instructions of manufacturer or fabricator of product installed, using only cleaning materials specifically recommended. If specific cleaning materials are not recommended, use cleaning materials that are not hazardous to health or property and that will not damage exposed surfaces.
- E. Concealed Spaces: Remove debris from concealed spaces before enclosing the space.
- F. Exposed Surfaces: Clean exposed surfaces and protect as necessary to ensure freedom from damage and deterioration at time of Substantial Completion.
- G. Cutting and Patching: Clean areas and spaces where cutting and patching are performed. Completely remove paint, mortar, oils, putty, and similar materials.
 - 1. Thoroughly clean piping, conduit, and similar features before applying paint or other finishing materials. Restore damaged pipe covering to its original condition.
- H. Waste Disposal: Burying or burning waste materials on-site will not be permitted. Washing waste materials down sewers or into waterways will not be permitted.
- I. During handling and installation, clean and protect construction in progress and adjoining materials already in place. Apply protective covering where required to ensure protection from damage or deterioration at Substantial Completion.
- J. Clean and provide maintenance on completed construction as frequently as necessary through the remainder of the construction period. Adjust and lubricate operable components to ensure operability without damaging effects.
- K. Limiting Exposures: Supervise construction operations to assure that no part of the construction, completed or in progress, is subject to harmful, dangerous, damaging, or otherwise deleterious exposure during the construction period.

2.07 STARTING AND ADJUSTING

- A. Start equipment and operating components to confirm proper operation. Remove malfunctioning units, replace with new units, and retest.
- B. Adjust operating components for proper operation without binding. Adjust equipment for proper operation.
- C. Test each piece of equipment to verify proper operation. Test and adjust controls and safeties. Replace damaged and malfunctioning controls and equipment.
- D. Manufacturer's Field Service: If a factory-authorized service representative is required to inspect field-assembled components and equipment installation, comply with qualification requirements in Division 1 Section "Quality Requirements."

2.08 PROTECTION OF INSTALLED CONSTRUCTION

- A. Provide final protection and maintain conditions that ensure installed Work is without damage or deterioration at time of Substantial Completion.
- B. Comply with manufacturer's written instructions for temperature and relative humidity.

2.09 CORRECTION OF THE WORK

- A. Repair or remove and replace defective construction. Restore damaged substrates and finishes. Comply with requirements in Division 1 Section "Cutting and Patching."
 - 1. Repairing includes replacing defective parts, refinishing damaged surfaces, touching up with matching materials, and properly adjusting operating equipment.
- B. Restore permanent facilities used during construction to their specified condition.
- C. Remove and replace damaged surfaces that are exposed to view if surfaces cannot be repaired without visible evidence of repair.
- D. Repair components that do not operate properly. Remove and replace operating components that cannot be repaired.
- E. Remove and replace chipped, scratched, and broken glass or reflective surfaces.

END OF SECTION

SECTION 01770 - CLOSEOUT PROCEDURES

PART 1 - GENERAL

1.01 RELATED DOCUMENTS

- A. Drawings and general provisions of the Contract, including General and Supplementary Conditions and other Division 1 Specification Sections, apply to this Section.

1.02 SUMMARY

- A. Section includes administrative and procedural requirements for contract closeout, including, but not limited to, the following:
 - 1. Inspection procedures.
 - 2. Project Record Documents.
 - 3. Operation and maintenance manuals.
 - 4. Warranties.
 - 5. Instruction of Owner's personnel.
 - 6. Final cleaning.
- B. Related Sections include the following:
 - 1. Division 1 Section Payment Procedures for requirements for Applications for Payment for Substantial and Final Completion.
 - 2. Division 1 Section Execution Requirements for progress cleaning of Project site.
 - 3. Divisions 2 through 16 Sections for specific closeout and special cleaning requirements for products of those Sections.

1.03 SUBSTANTIAL COMPLETION

- A. Preliminary Procedures: Before requesting inspection for determining date of Substantial Completion, complete the following. List items below that are incomplete in request.
 - 1. Prepare a list of items to be completed and corrected (punch list), the value of items on the list, and reasons why the Work is not complete.
 - 2. Advise Owner of pending insurance changeover requirements.
 - 3. Submit specific warranties, workmanship bonds, maintenance service agreements, final certifications, and similar documents.
 - 4. Obtain and submit releases permitting Owner unrestricted use of the Work and access to services and utilities. Include occupancy permits, operating certificates, and similar releases.
 - a. Apply for and obtain from the Building Official a Certificate of Occupancy in the Owner's name.
 - b. The Certificate is to be obtained and posted as required by the Building Official prior to the final inspection by the Owner.
 - c. Temporary Certificate in lieu of a Certificate of Occupancy will be sufficient, as the Owner's prerequisite for his final inspection, only when his specific written approval has been obtained.

5. Prepare and submit Project Record Documents, operation and maintenance manuals, Final Completion construction photographs, damage or settlement surveys, property surveys, and similar final record information.
 6. Deliver tools, spare parts, extra materials, and similar items to location designated by Owner. Label with manufacturer's name and model number where applicable.
 7. Make final changeover of permanent locks and deliver keys to Owner. Advise Owner's personnel of changeover in security provisions.
 8. Complete startup testing of systems.
 9. Submit test/adjust/balance records.
 10. Terminate and remove temporary facilities from Project site, along with mockups, construction tools, and similar elements.
 11. Advise Owner of changeover in heat and other utilities.
 12. Submit changeover information related to Owner's occupancy, use, operation, and maintenance.
 13. Complete final cleaning requirements, including touchup painting.
 14. Touch up and otherwise repair and restore marred exposed finishes to eliminate visual defects.
- B. Inspection: Submit a written request for inspection for Substantial Completion. On receipt of request, Architect will either proceed with inspection or notify Contractor of unfulfilled requirements. Architect will prepare the Certificate of Substantial Completion after inspection or will notify Contractor of items, either on Contractor's list or additional items identified by Architect, that must be completed or corrected before certificate will be issued.
1. Re-inspection: Request re-inspection when the Work identified in previous inspections as incomplete is completed or corrected.
 2. Results of completed inspection will form the basis of requirements for Final Completion.

1.04 FINAL COMPLETION

- A. Preliminary Procedures: Before requesting final inspection for determining date of Final Completion, complete the following:
1. Submit a final Application for Payment according to Division 1 Section Payment Procedures.
 2. Submit certified copy of Architect's Substantial Completion inspection list of items to be completed or corrected (punch list), endorsed and dated by Architect. The certified copy of the list shall state that each item has been completed or otherwise resolved for acceptance.
 3. Submit evidence of final, continuing insurance coverage complying with insurance requirements.
 4. Submit pest-control final inspection report and warranty.
 5. Instruct Owner's personnel in operation, adjustment, and maintenance of products, equipment, and systems.
- B. Inspection:
1. Submit a written request for final inspection for acceptance. On receipt of request, Architect will either proceed with inspection or notify Contractor of unfulfilled requirements. Architect will prepare a final Certificate for Payment after inspection or will notify Contractor of construction that must be completed or corrected before certificate will be issued.

2. Re-inspection: Request re-inspection when the Work identified in previous inspections as incomplete is completed or corrected.

1.05 TERMINAL INSPECTION

- A. Immediately prior to expiration of the one-year correction period, conduct an inspection of the Work in the company of the Owner's Representative and the Owner. Notify the Owner's Representative and the Owner not less than 5 days notice prior to the anticipated date of terminal inspection.
- B. Where any portion of the Work has proven to be defective and required replacement, repair or adjustment,
- C. Provide materials and labor necessary to remedy such defective Work and shall prosecute such Work without delay until completed to the satisfaction of the Owner's Representative and the Owner, even though the date of completion of corrective Work may extend beyond the expiration date of the guarantee period.
- D. The Contractor shall not be responsible for:
 1. Correcting Work which has been damaged because of neglect or abuse by the Owner.
 2. Replacing parts necessitated by normal wear in use.

1.06 LIST OF INCOMPLETE ITEMS (PUNCH LIST)

- A. Preparation: Submit three copies of list. Include name and identification of each space and area affected by construction operations for incomplete items and items needing correction including, if necessary, areas disturbed by Contractor that are outside the limits of construction.
 1. Organize list of spaces in sequential order, starting with exterior areas first and proceeding from lowest floor to highest floor, where applicable.
 2. Organize items applying to each space by major element, including categories for ceiling, individual walls, floors, equipment, and building systems.
 3. Include the following information at the top of each page:
 - a. Project name.
 - b. Date.
 - c. Name of Architect.
 - d. Name of Contractor.
 - e. Page number.

1.07 PROJECT RECORD DOCUMENTS

- A. General: Do not use Project Record Documents for construction purposes. Protect Project Record Documents from deterioration and loss. Provide access to Project Record Documents for Architect's reference during normal working hours.
- B. Record Drawings: Maintain and submit one set of black-line white prints of Contract Drawings and Shop Drawings.
 1. Mark Record prints to show the actual installation where installation varies from that shown originally. Require individual or entity who obtained record data, whether individual or entity is Installer, subcontractor, or similar entity, to prepare the marked-up Record Prints.
 - a. Give particular attention to information on concealed elements that cannot be readily identified and recorded later.
 - b. Accurately record information in an understandable drawing technique.

- c. Record data as soon as possible after obtaining it. Record and check the markup before enclosing concealed installations.
- d. Mark Contract Drawings or Shop Drawings, whichever is most capable of showing actual physical conditions, completely and accurately. Where Shop Drawings are marked, show cross-reference on Contract Drawings.
- e. Each sheet of the prints shall be certified as to correctness by the Contractor, and where any major portion of the Work is performed by a Subcontractor, the tracings reflecting said subcontract Work shall be properly countersigned by the Subcontractor. Certify record drawing prints as follows:

**CERTIFIED CORRECT (3/8-inch high letters)
(Name of Subcontractor)**

By: _____

Date: _____

- f. After all corrections, changes and deviations have been transferred to the prints, the Contractor shall submit the prints to the Architect for review and comments. If additional information is required, or if the drawings are incomplete, the Architect will return the prints to the Contractor for required action. If the record drawings are complete, the Contractor shall, upon notice by the Architect, submit the record drawing prints to the Architect for delivery to the Owner.
2. Mark record sets with erasable, red-colored pencil. Use other colors to distinguish between changes for different categories of the Work at the same location.
 3. Mark important additional information that was either shown schematically or omitted from original Drawings.
 4. Note Construction Change Directive numbers, Change Order numbers, alternate numbers, and similar identification where applicable.
 5. Identify and date each Record Drawing; include the designation PROJECT RECORD DRAWING in a prominent location. Organize into manageable sets; bind each set with durable paper cover sheets. Include identification on cover sheets.
- C. Record Specifications: Submit one copy of Project's Specifications, including addenda and contract modifications. Mark copy to indicate the actual product installation where installation varies from that indicated in Specifications, addenda, and contract modifications.
1. Give particular attention to information on concealed products and installations that cannot be readily identified and recorded later.
 2. Mark copy with the proprietary name and model number of products, materials, and equipment furnished, including substitutions and product options selected.
 3. Note related Change Orders, Record Drawings, and Product Data, where applicable.
- D. Miscellaneous Record Submittals: Assemble miscellaneous records required by other Specification Sections for miscellaneous record keeping and submittal in connection with actual performance of the Work. Bind or file miscellaneous records and identify each, ready for continued use and reference.

1.08 OPERATION AND MAINTENANCE MANUALS

- A. Assemble a complete set of operation and maintenance data indicating the operation and maintenance of each system, subsystem, and piece of equipment not part of a system. Include operation and maintenance data required in individual Specification Sections and as follows:
 - 1. Operation Data:
 - a. Emergency instructions and procedures.
 - b. System, subsystem, and equipment descriptions, including operating standards.
 - c. Operating procedures, including startup, shutdown, seasonal, and weekend operations.
 - d. Description of controls and sequence of operations.
 - e. Piping diagrams.
 - 2. Maintenance Data:
 - a. Manufacturer's information, including list of spare parts.
 - b. Name, address, and telephone number of Installer or supplier.
 - c. Maintenance procedures.
 - d. Maintenance and service schedules for preventive and routine maintenance.
 - e. Maintenance record forms.
 - f. Sources of spare parts and maintenance materials.
 - g. Copies of maintenance service agreements.
 - h. Copies of warranties and bonds.
- B. Organize operation and maintenance manuals into suitable sets of manageable size. Bind and index data in heavy-duty, 3-ring, vinyl-covered, loose-leaf binders, in thickness necessary to accommodate contents, with pocket inside the covers to receive folded oversized sheets. Identify each binder on front and spine with the printed title OPERATION AND MAINTENANCE MANUAL, Project name, and subject matter of contents.

1.09 WARRANTIES

- A. General:
 - 1. Execute warranties required by the Contract Documents in the Owner's name.
 - 2. Warranties for materials, appliances, and equipment furnished by others and incorporated in the Work must be transferable/assignable to the Owner in such manner that warranty provisions will be enforceable by the Owner.
 - 3. Prior to making application for final payment, collect and deliver all required warranties to the Architect for review and transmittal to the Owner.
- B. Submittal Time: Submit written warranties on request of Architect for designated portions of the Work where commencement of warranties other than date of Substantial Completion is indicated.
- C. Partial Occupancy: Submit properly executed warranties within 15 days of completion of designated portions of the Work that are completed and occupied or used by Owner during construction period by separate agreement with Contractor.
- D. Organize warranty documents into an orderly sequence based on the table of contents of the Project Manual.
 - 1. Bind warranties and bonds in heavy-duty, 3-ring, vinyl-covered, loose-leaf binders, thickness as necessary to accommodate contents, and sized to receive 8-1/2-by-11-inch paper.

2. Provide heavy paper dividers with plastic-covered tabs for each separate warranty. Mark tab to identify the product or installation. Provide a typed description of the product or installation, including the name of the product and the name, address, and telephone number of Installer.
 3. Identify each binder on the front and spine with the typed or printed title WARRANTIES, Project name, and name of Contractor.
- E. Provide additional copies of each warranty to include in operation and maintenance manuals.

PART 2 - PRODUCTS

2.01 MATERIALS

- A. Cleaning Agents: Use cleaning materials and agents recommended by manufacturer or fabricator of the surface to be cleaned. Do not use cleaning agents that are potentially hazardous to health or property or that might damage finished surfaces.

PART 3 - EXECUTION

3.01 DEMONSTRATION AND TRAINING

- A. Instruction: Instruct Owner's personnel to adjust, operate, and maintain systems, subsystems, and equipment not part of a system.
1. Provide instructors experienced in operation and maintenance procedures.
 2. Provide instruction at mutually agreed-on times. For equipment that requires seasonal operation, provide similar instruction at the start of each season.
 3. Schedule training with Owner, through Architect, with at least seven days' advance notice.
 4. Coordinate instructors, including providing notification of dates, times, length of instruction, and course content.
- B. Program Structure: Develop an instruction program that includes individual training modules for each system and equipment not part of a system, as required by individual Specification Sections. For each training module, develop a learning objective and teaching outline. Include instruction for the following:
1. System design and operational philosophy.
 2. Review of documentation.
 3. Operations.
 4. Adjustments.
 5. Troubleshooting.
 6. Maintenance.
 7. Repair.

3.02 FINAL CLEANING

- A. General: Provide final cleaning. Conduct cleaning and waste-removal operations to comply with local laws and ordinances and Federal and local environmental and anti-pollution regulations.
- B. Cleaning:
1. Employ experienced workers or professional cleaners for final cleaning. Clean each surface or unit to condition expected in an average commercial building cleaning and maintenance program. Comply with manufacturer's written instructions.

2. Complete the following cleaning operations before requesting inspection for certification of Substantial Completion for entire Project or for a portion of Project:
 - a. Clean Project site, yard, and grounds, in areas disturbed by construction activities, including landscape development areas, of rubbish, waste material, litter, and other foreign substances.
 - b. Sweep paved areas broom clean. Remove petrochemical spills, stains, and other foreign deposits.
 - c. Rake grounds that are neither planted nor paved to a smooth, even-textured surface.
 - d. Remove tools, construction equipment, machinery, and surplus material from Project site.
 - e. Remove snow and ice to provide safe access to building.
 - f. Clean exposed exterior and interior hard-surfaced finishes to a dirt-free condition, free of stains, films, and similar foreign substances. Avoid disturbing natural weathering of exterior surfaces. Restore reflective surfaces to their original condition.
 - g. Remove debris and surface dust from limited access spaces, including roofs, plenums, shafts, trenches, equipment vaults, manholes, attics, and similar spaces.
 - h. Sweep concrete floors broom clean in unoccupied spaces.
 - i. Vacuum carpet and similar soft surfaces, removing debris and excess nap; shampoo if visible soil or stains remain.
 - j. Clean transparent materials, including mirrors and glass in doors and windows. Remove glazing compounds and other noticeable, vision-obscuring materials. Replace chipped or broken glass and other damaged transparent materials. Polish mirrors and glass, taking care not to scratch surfaces.
 - k. Remove labels that are not permanent.
 - l. Touch up and otherwise repair and restore marred, exposed finishes and surfaces. Replace finishes and surfaces that cannot be satisfactorily repaired or restored or that already show evidence of repair or restoration.
 - (1) Do not paint over UL and similar labels, including mechanical and electrical nameplates.
 - m. Wipe surfaces of mechanical and electrical equipment, elevator equipment, where applicable and similar equipment. Remove excess lubrication, paint and mortar droppings, and other foreign substances.
 - n. Replace parts subject to unusual operating conditions.
 - o. Clean plumbing fixtures to a sanitary condition, free of stains, including stains resulting from water exposure.
 - p. Replace disposable air filters and clean permanent air filters. Clean exposed surfaces of diffusers, registers, and grills.
 - q. Clean ducts, blowers, and coils if units were operated without filters during construction.
 - r. Clean light fixtures, lamps, globes, and reflectors to function with full efficiency. Replace burned-out bulbs, and those noticeably dimmed by hours of use, and defective and noisy starters in fluorescent and mercury vapor fixtures to comply with requirements for new fixtures.
 - s. Leave Project clean and ready for occupancy.

- C. Pest Control: Engage an experienced, licensed exterminator to make a final inspection and rid Project of rodents, insects, and other pests. Prepare a report.
- D. Comply with safety standards for cleaning. Do not burn waste materials. Do not bury debris or excess materials on Owner's property. Do not discharge volatile, harmful, or dangerous materials into drainage systems. Remove waste materials from Project site and dispose of lawfully.

END OF SECTION

SECTION 02750 – CONCRETE PAVING

PART 1 - GENERAL

1.01 RELATED DOCUMENTS

- A. Drawings and general provisions of the Contract, including General and Supplementary Conditions and Division 1 Specification Sections, apply to this Section.

1.02 SUMMARY

- A. Section includes Portland cement concrete pavement on prepared subgrades constructed to designated thickness and line grade, and typical cross section, as shown.

1.03 SUBMITTALS

- A. Submit manufacturer's acknowledgement letter. Follow Division 1 Section "Submittal Procedures."
- B. Submit product data. Include installation instructions, recommendations for each product, and data substantiating that materials comply with specified requirements.

1.04 WARRANTY

- A. Warrant concrete pavement for 2 years against becoming unserviceable as a result of faulty materials of improper workmanship.

PART 2 - PRODUCTS

2.01 MATERIALS

- A. Cement: Portland cement, ASTM C 150, Type I.
- B. Water: Clean and free from injurious amount of oils, acids, alkalis or other deleterious substances.
- C. Aggregates: ASTM C33. Maximum coarse aggregate size shall be 1-1/2 inches or less, and fine aggregate shall be clean, washed sand, free of injurious matter.
- D. Air Entraining Agent: ASTM C-260.
- E. Retardant: Retardant is required when the temperature exceeds 85 degrees F. Use the same brand as used for the air entraining agent.
- F. Reinforcing Steel:
 - 1. Billet Steel: ASTM A 615, grade 40.
 - 2. Wire Fabric: ASTM A 82 in gauge and facing indicated.
- G. Curing Compound: White liquid membrane forming type; conform to ASTM C 309.

2.02 PROPORTIONING

- A. Concrete Mix Design: Select proportion of ingredients to produce concrete having proper placability, durability, strength, appearance, and other required properties. Proportioning of the concrete mix is the responsibility of the Contractor subject to specified requirements.
 - 1. Minimum Compressive Strength: 2,100 psi at 7 days and 3,000 psi at 28 days.
 - 2. Cement Content: 470 lb. per cubic yard (5.0 U.S. bags) minimum.
 - 3. Entrained Air Content: 3 percent of air by volume of concrete.

4. Maximum Water Content: 6.0 gallons of water per U.S. bag of cement.
5. Maximum Allowable Slump: 4 inches when gauged by standard slump test.

2.03 EXPANSION JOINTS

- A. Load Transfer Unit: As manufactured by Shepler's, Houston, Texas or approved equal.
 1. Steel Dowels: 3/4-inch dia. by 10 inches long with plastic dowel tube on one side.
 2. Spacing dowels at the same spacing as the paving reinforcing.
 3. Locations:
 - a. At maximum 40 feet apart each way.
 - b. Where Work abuts other permanent construction.
- B. Tooled Joints:
 1. Size: 1/2-inch by 1/2-inch.
 2. Locations: Maximum 20'-0" on center each way between expansion joints.
- C. Concrete Paving Joint Sealant: Provide sealants complying with ASTM C920, Type M, Grade P, Class 25, Use T, M and O
 1. Multicomponent Nonsag Urethane Sealant: Use one of the following Products or a comparable product approved by the Architect:
 - a. Sika Corporation, Inc.; Sikaflex - 2c NS TG.
 - b. Sonneborn, Division of ChemRex Inc.; NP 2.
 - c. Tremco; Vulkem 227.
 2. Single-Component Pourable Urethane Sealant: Use one of the following Products or a comparable product approved by the Architect:
 - a. Sika Corporation, Inc.; Sikaflex - 1CSL.
 - b. Sonneborn, Division of ChemRex Inc.; SL 1.

PART 3 - EXECUTION

3.01 SUBGRADE

- A. Preparation:
 1. Comply with recommendations published in the Geotechnical Report (issued separately and available from Architect).

3.02 JOINTS

- A. Place joints of the type shown on drawings at required locations and at spacings shown. Contractor shall provide a layout for Architect's approval.
- B. If type of joints, locations or spacings is not shown on the plans, submit a joint layout plan with joint details prior to construction for approval.

3.03 WEATHER CONDITIONS

- A. Place concrete only when the air temperature is above 35 degree F. The Contractor is responsible for the quality and strength of concrete placed under any weather conditions.

3.04 REINFORCING STEEL

- A. Accurately place Reinforcing Steel in accordance with details. Wire reinforcing bars securely together at intersections and splices. Place all reinforcing steel and secure to chairs.

3.05 CONCRETE PLACEMENT

- A. Ready-mixed concrete hauled in truck mixers or truck agitators shall be deposited in place within 90 minutes from the time the water is added to the mix. Retempering concrete by adding water or by other means shall not be permitted. Concrete that is unsuitable for placement as delivered shall be rejected.
 - 1. Before placing concrete shall be placed, struck off, and consolidated with a mechanical finishing machine, vibrating screed, or by hand-finishing methods when approved by the Engineer. If a screed is used, a depth of at least 2 inches of concrete should be carried in front of the screed for the full width of the pavement.
 - 2. The concrete shall be placed, struck off and consolidated with a mechanical finishing machine, vibrating screed, or by hand-finishing methods when approved by the Engineer. If a screed is used, a depth of at least 2 inches of concrete should be carried in front of the screed for the full width of the pavement.
- B. Construct concrete paving using Portland Cement Concrete Pavement which conforms to City of Houston Standard Specification Item 103. Provide following minimum thickness of concrete, using locations shown on site plan:
 - 1. 5 inches for light traffic.
 - 2. 7 inches for heavy traffic.
- C. Finishing:
 - 1. After concrete has been struck off and consolidated, a bullfloat may be used to remove any high or low spots. Bullfloat use shall be confined to a minimum.
 - 2. Provide final skid-resistant finish with a burlap drag or broom.
- D. Curing:
 - 1. Concrete shall be cured by protecting it against loss of moisture, rapid temperature change, and mechanical injury for at least 3 days after placement. After all free water has disappeared from the surface, a liquid membrane-forming compound shall be uniformly sprayed on all exposed surfaces.
 - 2. Provision shall be made to protect the freshly cast concrete from damage due to intermittent precipitation by providing plastic sheeting or other suitable material along the line of Work.
 - 3. Concrete injured by frost action shall be removed and replaced at the Contractor's expense.
- E. Testing:
 - 1. Use a commercial laboratory to make slump test, and cylinders for compressive strengths.
 - 2. The laboratory will promptly furnish written reports covering results of tests and inspections to the Engineer and the Contractor.
- F. Protection and Opening Pavement to Traffic:
 - 1. Do not open pavement to pedestrian traffic for at least 72 hours during the curing period.
 - 2. Do not open pavement to traffic until concrete is at least 14 days old.
 - 3. Opening of pavement to traffic in no way relieves the Contractor from his responsibility for the Work.

END OF SECTION

SECTION 03300 - CAST-IN-PLACE CONCRETE

PART 1 - GENERAL

1.01 RELATED DOCUMENTS

- A. Drawings and general provisions of the Contract, including General and Supplementary Conditions and Division 1 Specification Sections, apply to this Section.

1.02 SUMMARY

- A. Section Includes: Cast-In-Place Concrete, including formwork, reinforcing, mix design, placement procedures, and finishes.
- B. Related Work: Concrete paving and walks are specified in Division 2.

1.03 SUBMITTALS

- A. Submit manufacturer's acknowledgement letter. Follow Division 1 Section "Submittal Procedures."
- B. Submit Manufacturer's Technical Product Data, installation instructions, and recommendations for each product. Include data substantiating that materials comply with specified requirements.
 - 1. Product data for proprietary materials and items, including reinforcement and forming accessories, admixtures, patching compounds, joint systems, curing compounds, and others as requested by Architect.
- C. Submit shop drawings for reinforcement to show fabrication, bending, and placement of concrete reinforcement. Comply with ACI SP-66 (88), "*ACI Detailing Manual*," showing bar schedules, stirrup spacing, diagrams of bent bars, and arrangement of concrete reinforcement. Include special reinforcement required for openings through concrete structures.
- D. Laboratory test reports for concrete materials and mix design test.
- E. Materials Certificates in lieu of Material Laboratory Test Reports when permitted by Architect. Materials Certificates shall be signed by Manufacturer and Contractor, certifying that each material item complies with or exceeds specified requirements. Provide certification from admixture manufacturers that chloride content complies with specification requirements.

1.04 QUALITY ASSURANCE

- A. Codes and Standards: Comply with provisions of following codes, specifications, and standards, except where more stringent requirements are shown or specified:
 - 1. ACI 318, "Building Code Requirements for Reinforced Concrete."
 - 2. Concrete Reinforcing Steel Institute (CRSI), "*Manual of Standard Practice*."
- B. Materials and installed Work may require testing and retesting at any time during progress of Work. Tests, including retesting of rejected materials for installed Work, shall be done at Contractor's expense.

PART 2 - PRODUCTS

2.01 FORM MATERIALS

- A. Forms for Exposed Finish Concrete: Plywood, metal, metal-framed plywood faced, or other acceptable panel-type materials, to provide continuous, straight, smooth, exposed surfaces. Furnish in largest practicable sizes to minimize number of joints and to conform to joint system shown on drawings.
 - 1. Use plywood complying with U.S. Product Standard PS-1 "B-B (Concrete Form) Plywood," Class I, Exterior Grade or better, mill-oiled and edge-sealed, with each piece bearing legible inspection trademark.
- B. Forms for Unexposed Finish Concrete: Plywood, lumber, metal, or other acceptable material. Provide lumber dressed on at least 2 edges and one side for tight fit. Stain, or adversely affect concrete surfaces and will not impair subsequent treatments of concrete surfaces.

2.02 REINFORCING MATERIALS

- A. Reinforcing Bars: ASTM A 615, Grade 60 unless indicated otherwise on Drawings. All bars shall be deformed.
- B. Welded Wire Fabric: ASTM A 185, welded steel wire fabric.
- C. Supports for Reinforcement: Bolsters, chairs, spacers, and other devices for spacing, supporting, and fastening reinforcing bars and welded wire fabric in place. Use wire-bar-type supports complying with CRSI specifications.
 - 1. For slabs-on-grade, use supports with sand plates or horizontal runners where base material will not support chair legs.
 - 2. For exposed-to-view concrete surfaces, where legs of supports are in contact with forms, provide supports with legs that are plastic protected (CRSI, Class 1).

2.03 CONCRETE MATERIALS

- A. Portland Cement: ASTM C 150, Type I.
 - 1. Use one brand of cement throughout the project, unless otherwise acceptable to the Architect.
- B. Fly Ash: See Structural drawings.
- C. Normal Weight Aggregates: ASTM C 33 and as herein specified. Provide aggregates from a single source for exposed concrete.
 - 1. For exterior exposed surfaces, do not use fine or coarse aggregates containing spalling-causing deleterious substances.
- D. Water: Drinkable.
- E. Admixtures, General: Provide admixtures for concrete that contain not more than 0.1 percent chloride ions.
- F. Air-Entraining Admixture: ASTM C 260, certified by manufacturer to be compatible with other required admixtures.
 - 1. Available Products: Subject to compliance with requirements, products that may be incorporated in the Work include, but are not limited to the following:
 - a. "Air-Mix", Euclid Chemical Co.
 - b. "Darex AEA" or "Daravair", W.R. Grace & Co.
 - c. "MB-VR" or "Micro-Air", Master Builders, Inc.
 - d. "Sealtight AEA", W.R. Meadows, Inc.

- e. “Sika AER”, Sika Corp.
- G. Water-Reducing Admixture: ASTM C 494, Type A.
 - 1. Available Products: Subject to compliance with requirements, products that may be incorporated in the Work include, but are not limited to the following:
 - a. “Eucon WR-75 or WR-89”, Euclid Chemical Co.
 - b. “Pozzolith 200-N”, Master Builders, Inc.
 - c. “Plastocrete 160”, Sika Corp.
- H. Water Reducing, Retarding Admixture: The admixture shall conform to ASTM C494, Type D and not contain more chloride ions than are present in municipal drinking water.
 - 1. Available Products: Subject to compliance with requirements, products that may be incorporated in the Work include, but are not limited to the following:
 - a. “Eucon Retarder-75:”, The Euclid Chemical Company
 - b. “Pozzolith 100XR”; Master Builders
 - c. “Plastiment”; Sika Chemical Co.
 - d. “WRDA w/Hycol”; W.R. Grace & Co.
- I. High-Range Water-Reducing Admixture (Super Plasticizer): ASTM C494, Type F or G and not contain more chloride ions than are present in municipal drinking water.
 - 1. Available Products: Subject to compliance with requirements, products that may be incorporated in the Work include, but are not limited to, the following:
 - a. “Eucon 37”, Euclid Chemical Co.
 - b. “Rheobuild 1000”, Master Builders, Inc.
 - c. “Sikament 300”, Sika Corp.
- J. Non-Corrosive, Non-Chloride Accelerating Admixture: The admixture shall conform to ASTM C494, Type C or E, and not contain more chloride ions than are present in municipal drinking water. The admixture manufacturer shall have long-term non-corrosive test data from an independent testing laboratory (of at least a year's duration) using acceptable accelerated corrosion test method such as that using electrical potential measures.
 - 1. Available Products: Subject to compliance with requirements, products that may be incorporated in the Work include, but are not limited to the following:
 - a. “Accelguard 80”, Euclid Chemical Co.
 - b. “Daraset”, W.R. Grace & Co.
- K. Prohibited Admixtures: Calcium chloride, thiocyanates, or admixtures containing more than 0.05% chloride ions are not permitted. No admixture shall cause an increase in shrinkage when tested in accordance with ASTM C494 and ASTM C157.
- L. Certification: Written conformance to the above mentioned requirements and the chloride ion content of the admixture will be required from the admixture manufacturer prior to mix design review by the Architect.

2.04 RELATED MATERIALS

- A. Underslab Vapor Retarder: Per Division 7 Section “Underslab Vapor Barrier”
- B. Moisture-Retaining Cover: One of the following, complying with ASTM C 171.
 - 1. Waterproof paper.
 - 2. Polyethylene film.
 - 3. Polyethylene-coated burlap.
- C. Underlayment Compound: Free-flowing, self-leveling, pumpable, cement-based compound for applications from one inch thick to feathered edges.

1. Available Products: Subject to compliance with requirements, products that may be incorporated in the Work include, but are not limited to the following:
 - a. "K-15," Ardex, Inc.
 - b. "Thoro Underlayment Self-Leveling", Thoro System Products.
- D. Bonding Compound: Polyvinyl acetate or acrylic base.
 1. Available Products: Subject to compliance with requirements, products that may be incorporated in the Work include, but are not limited to, the following:
 - a. Polyvinyl Acetate (Interior Only):
 - (1) "Superior Concrete Bonder", Dayton Superior Corp.
 - (2) "Euco Weld", Euclid Chemical Co.
 - (3) "Weld-Crete", Larsen Products Corp.
 - (4) "Everweld", L&M Construction Chemicals, Inc.
 - b. Acrylic or Styrene Butadiene:
 - (1) "Acrylic Bondcrete", The Burke Co.
 - (2) "Strongbond", Conspec Marketing and Mfg. Co.
 - (3) "Day-Chem Ad Bond", Dayton Superior Corp.
 - (4) "SBR Latex", Euclid Chemical Co.
 - (5) "Daraweld C", W.R. Grace & Co.
 - (6) "Hornweld", A.C. Horn, Inc.
 - (7) "Everbond," L & M Construction Chemicals, Inc.
 - (8) "Acryl-Set", Master Builders Inc.
 - (9) "Intralok", W.R. Meadows, Inc.
 - (10) "Sonocrete", Sonneborn-Rexnord.
 - (11) "Stonlock LB2", Stonhard, Inc.
- E. Epoxy Adhesive: ASTM C 881, two-component material suitable for use on dry or damp surfaces. Provide material "Type," "Grade," and "Class" to suit project requirements.
 1. Available Products: Subject to compliance with requirements, products that may be incorporated in the Work include, but are not limited to the following:
 - a. "Burke Epoxy M.V.," The Burke Co.
 - b. "Spec-Bond 100", Conspec Marketing and Mfg. Co.
 - c. "Euco Epoxy System #452 or #620," Euclid Chemical Co.
 - d. "Epoxite Binder 2390," A.C. Horn, Inc.
 - e. "Epabond", L&M Construction Chemicals, Inc.
 - f. "Concresive 1001", Master Builders, Inc.
 - g. "Sikadur 32 Hi-Mod", Sika Corp.

2.05 PROPORTIONING AND DESIGN OF MIXES

- A. Prepare design mixes for each type and strength of concrete by either laboratory trial batch, or field experience methods as specified in ACI 301.
- B. Submit written reports to Architect of each proposed mix for each class of concrete at least 15 days prior to the start of Work. Do not begin concrete production until proposed mix designs have been reviewed by Architect.
- C. Design mixes to provide normal weight concrete with the following properties, as indicated on drawings and schedules:
 1. As shown on Structural drawings.
- D. Adjustment to Concrete Mixes: Mix design adjustments may be requested by Contractor when characteristics of materials, job conditions, weather, test results, or other circumstances

warrant, as accepted by Architect. Laboratory test data for revised mix design and strength results must be submitted to and accepted by Architect before using in Work.

2.06 ADMIXTURES

- A. Use the specified water-reducing admixture or high-range, water-reducing admixture in concrete for placement and workability.
- B. Use non-chloride accelerating admixture in concrete slabs placed at ambient temperatures below 50 deg F.
- C. Use high-range water-reducing admixture (HRWR) in synthetic fiber pumped concrete, concrete for industrial slabs, concrete required to be watertight, and concrete with water/cement ratios below 0.50.
- D. Use air-entraining admixture in exterior exposed concrete unless otherwise indicated. Add air-entraining admixture at manufacturer's prescribed rate to result in concrete at point of placement having total air content with a tolerance of plus or minus 1-1/2 percent within following limits:
 - 1. Concrete structures and slabs exposed to freezing and thawing, deicer chemicals, or hydraulic pressure:
 - a. 4.5 percent (moderate exposure); 5.5 percent (severe exposure) 1-1/2-inch max. Aggregate.
 - b. 4.5 percent (moderate exposure); 6.0 percent (severe exposure) 1-inch max. Aggregate.
 - c. 5.0 percent (moderate exposure); 6.0 percent (severe exposure) 3/4-inch max. Aggregate.
 - d. 5.5 percent (moderate exposure); 7.0 percent (severe exposure) 1/2-inch max. Aggregate.
 - 2. Other concrete (not exposed to freezing, thawing, or hydraulic pressure) air content is optional. All interior slabs subject to vehicular abrasion shall have a maximum air content of 3%.
 - 3. Use admixtures for water reduction and set control in strict compliance with manufacturer's directions.
- E. Water-Cement Ratio: Provide concrete for following conditions with maximum water-cement (W/C) ratios as follows:
 - 1. Subjected to freezing and thawing; W/C 0.50.
 - 2. Subjected to deicers/watertight; W/C 0.45.
 - 3. Reinforced concrete subjected to brackish water, salt spray, or deicers: W/C 0.40.
- F. Slump Limits: Proportion and design mixes to result in concrete slump at point of placement as follows:
 - 1. Ramps, slabs, and sloping surfaces: Not more than 3 inches.
 - 2. Reinforced foundation systems: Not less than 3 inch and not more than 5 inches.
- G. Concrete containing HRWR admixture (Superplasticizer): Not more than 9 inches unless otherwise approved by the Architect. The concrete shall arrive at the job site at a slump of 2 inches to 3 inches (3 inches to 4 inches for concrete receiving "shake-on hardener"), be verified, the high-range water-reducing admixture added to increase the slump to the approved level.
 - 1. Other concrete: Not more than 4 inches.

2.07 CONCRETE MIXING

- A. Ready-Mix Concrete: Comply with requirements of ASTM C 94, and as specified.

1. When air temperature is between 85 deg F and 90 deg F, reduce mixing and delivery time from 1-1/2 hours to 75 minutes, and when air temperature is above 90 deg F, reduce mixing and delivery time to 60 minutes.

PART 3 - EXECUTION

3.01 GENERAL

- A. Coordinate the installation of joint materials and vapor retarders with placement of forms and reinforcing steel.

3.02 FORMS

- A. General: Design, erect, support, brace, and maintain formwork to support vertical and lateral, static and dynamic loads that might be applied until concrete structure can support such loads. Construct formwork so concrete members and structures are of correct size, shape, alignment, elevation, and position. Maintain formwork construction tolerances complying with ACI 347.
 1. Construct forms to sizes, shapes, lines, and dimensions shown to obtain accurate alignment, location, grades, level, and plumb Work in finished structures. Provide for openings, offsets, sinkages, keyways, recesses, moldings, rustications, reglets, chamfers, blocking, screeds, bulkheads, anchorages and inserts, and other features required in Work. Use selected materials to obtain required finishes. Solidly butt joints and provide backup at joints to prevent leakage of cement paste.
 2. Fabricate forms for easy removal without hammering or prying against concrete surfaces. Provide crush plates or wrecking plates where stripping may damage cast concrete surfaces. Provide top forms for inclined surfaces where slope is too steep to place concrete with bottom forms only. Kerf wood inserts for forming keyways, reglets, recesses, and the like, for easy removal.
 3. Provide temporary openings where interior area of formwork is inaccessible for clean-out, for inspection before concrete placement, and for placement of concrete. Securely brace temporary openings and set tightly to forms to prevent loss of concrete mortar. Locate temporary openings in forms at inconspicuous locations.
 4. Chamfer exposed corners and edges as indicated, using wood, metal, PVC, or rubber chamfer strips fabricated to produce uniform smooth lines and tight edge joints.
- B. Provisions for Other Trades: Provide openings in concrete formwork to accommodate Work of other trades. Determine size and location of openings, recesses, and chases from trades providing such items. Accurately place and securely support items built into forms.
- C. Cleaning and Tightening: Thoroughly clean forms and adjacent surfaces to receive concrete. Remove chips, wood, sawdust, dirt, or other debris just before concrete is placed. Re-tighten forms and bracing before concrete placement as required to prevent mortar leaks and maintain proper alignment.

3.03 VAPOR RETARDER/BARRIER INSTALLATION

- A. Comply with division 7 section "Underslab Vapor Retarder"

3.04 PLACING REINFORCEMENT

- A. General: Comply with Concrete Reinforcing Steel Institute's recommended practice for "Placing Reinforcing Bars," for details and methods of reinforcement placement and supports and as herein specified.

1. Avoiding cutting or puncturing vapor retarder during reinforcement placement and concreting operations.
2. Clean reinforcement of loose rust and mill scale, earth, ice, and other materials that reduce or destroy bond with concrete.
3. Accurately position, support, and secure reinforcement against displacement. Locate and support reinforcing by metal chairs, runners, bolsters, spacers, and hangers, as approved by Architect.
4. Place reinforcement to obtain at least minimum coverages for concrete protection. Arrange, space, and securely tie bars and bar supports to hold reinforcement in position during concrete placement operations. Set wire ties so ends are directed into concrete, not toward exposed concrete surfaces.
5. Install welded wire fabric in as long lengths as practicable. Lap adjoining pieces at least one full mesh and lace splices with wire. Offset laps of adjoining widths to prevent continuous laps in either direction.

3.05 JOINTS

- A. Construction Joints: Locate and install construction joints as indicated, or if not indicated, locate so as not to impair strength and appearance of the structure, as acceptable to Architect.
 1. Place construction joints perpendicular to main reinforcement. Continue reinforcement across construction joints except as otherwise indicated. Do not continue reinforcement through sides of strip placements.
 2. Use bonding agent or epoxy adhesive on existing concrete surfaces that will be joined with fresh concrete.
- B. Isolation Joints in Slabs-on-Ground: Construct isolation joints in slabs-on-ground at points of contact between slabs-on-ground and vertical surfaces, such as column pedestals, foundation walls, grade beams, and elsewhere as indicated.
 1. Joint filler and sealant materials are specified in Division 7 Sections of these specifications.
- C. Contraction (Control) Joints in Slabs-on-Ground: Unless indicated otherwise on Drawings, the Soff-Cut saw shall be used immediately after final finishing and to a depth of 1-1/4 inches. A conventional saw shall be used as soon as possible without dislodging aggregate and to a depth of 1/4 the slab thickness.
 1. If joint spacing is not shown, maximum joint spacing shall be 36 times the slab thickness to bay spacing wherever possible (at column center lines, half bays, third bays).
 2. Contraction joints in unexposed floor slabs may be formed by saw cuts as soon as possible after slab finishing as may be safely done without dislodging aggregate.

3.06 INSTALLATION OF EMBEDDED ITEMS

- A. General: Set and build into Work anchorage devices and other embedded items required for other Work that is attached to, or supported by cast-in-place concrete. Use setting drawings, diagrams, instructions, and directions provided by suppliers of items to be attached thereto.
- B. Forms for Slabs: Set edge forms, bulkheads, and intermediate screed strips for slabs to obtain required elevations and contours in finished surfaces. Provide and secure units to support screed strips using strike-off templates or compacting-type screeds.

3.07 PREPARATION OF FORM SURFACES

- A. General: Coat contact surfaces of forms with an approved, nonresidual, low-VOC, form-coating compound before reinforcement is placed.

1. Do not allow excess form-coating material to accumulate in forms or to come into contact with in-place concrete surfaces against which fresh concrete will be placed. Apply in compliance with manufacturer's instructions.

3.08 CONCRETE PLACEMENT

- A. Inspection: Before placing concrete, inspect and complete formwork installation, reinforcing steel, and items to be embedded or cast in. Notify other crafts to permit installation of their Work; cooperate with other trades in setting such Work.
- B. General: Comply with ACI 304, "Recommended Practice for Measuring, Mixing, Transporting, and Placing Concrete," and as herein specified.
 1. Deposit concrete continuously or in layers of such thickness that no concrete will be placed on concrete that has hardened sufficiently to cause the formation of seams or planes of weakness. If a section cannot be placed continuously, provide construction joints as herein specified. Deposit concrete to avoid segregation at its final location.
- C. Placing Concrete in Forms: Deposit concrete in forms in horizontal layers not deeper than 24 inches and in a manner to avoid inclined construction joints. Where placement consists of several layers, place each layer while preceding layer is still plastic to avoid cold joints.
 1. Consolidate placed concrete by mechanical vibrating equipment supplemented by hand-spading, rodding, or tamping. Use equipment and procedures for consolidation of concrete in accordance with ACI 309.
 2. Do not use vibrators to transport concrete inside forms. Insert and withdraw vibrators vertically at uniformly spaced locations not farther than visible effectiveness of machine. Place vibrators to rapidly penetrate placed layer and at least 6 inches into preceding layer. Do not insert vibrators into lower layers of concrete that have begun to set. At each insertion limit duration of vibration to time necessary to consolidate concrete and complete embedment of reinforcement and other embedded items without causing segregation of mix.
- D. Placing Concrete Slabs: Deposit and consolidate concrete slabs in a continuous operation, within limits of construction joints, until the placing of a panel or section is completed.
 1. Consolidate concrete during placing operations so that concrete is thoroughly worked around reinforcement and other embedded items and into corners.
 2. Bring slab surfaces to correct level with straightedge and strike off. Use highway straightedges, bull floats, or darbies to smooth surface, free of humps or hollows. Do not disturb slab surfaces prior to beginning finishing operations.
 3. Maintain reinforcing in proper position during concrete placement.
- E. Cold-Weather Placing: Comply with provisions of ACI 306 and as follows. Protect concrete Work from physical damage or reduced strength that could be caused by frost, freezing actions, or low temperatures.
 1. When air temperature has fallen to or is expected to fall below 40 deg F, uniformly heat water and aggregates before mixing to obtain a concrete mixture temperature of not less than 50 deg F and not more than 80 deg F at point of placement.
 - a. Do not use frozen materials or materials containing ice or snow. Do not place concrete on frozen sub-grade or on subgrade containing frozen materials.
 - b. Use only the specified non-corrosive non-chloride accelerator. Calcium chloride, thiocyanates, or admixtures containing more than 0.05% chloride ions are not permitted.

- F. Hot-Weather Placing: When hot weather conditions exist that would seriously impair quality and strength of concrete, place concrete in compliance with ACI 305 and as herein specified.
1. Cool ingredients before mixing to maintain concrete temperature at time of placement below 90 deg F. Mixing water may be chilled, or chopped ice may be used to control temperature provided water equivalent of ice is calculated to total amount of mixing water. Use of liquid nitrogen to cool concrete is Contractor's option.
 2. Cover reinforcing steel with water-soaked burlap if it becomes too hot, so that steel temperature will not exceed the ambient air temperature immediately before embedment in concrete.
 3. Fog spray forms, reinforcing steel, and subgrade just before concrete is placed.
 4. Use water-reducing retarding admixture when required by high temperatures, low humidity, or other adverse placing conditions, when acceptable to Architect.

3.09 FINISH OF FORMED SURFACES

- A. Rough Form Finish: For formed concrete surfaces not exposed to view in the finish Work or concealed by other construction. This is the concrete surface having texture imparted by form-facing material used, with tie holes and defective areas repaired and patched, and fins and other projections exceeding 1/4 inch in height rubbed down or chipped off.
- B. Smooth Rubbed Finish: Provide smooth rubbed finish to scheduled concrete surfaces, which have received smooth form finish treatment, not later than one day after form removal.
1. Moisten concrete surfaces and rub with carborundum brick or other abrasive until a uniform color and texture is produced. Do not apply cement grout other than that created by the rubbing process.
- C. Related Unformed Surfaces: At tops of walls, horizontal offsets, and similar unformed surfaces occurring adjacent to formed surfaces, strike-off, smooth and finish with a texture matching adjacent formed surfaces. Continue final surface treatment of formed surfaces uniformly across adjacent unformed surfaces, unless otherwise indicated.

3.10 MONOLITHIC SLAB FINISHES

- A. Scratch Finish: Apply scratch finish to monolithic slab surfaces to receive concrete floor topping or mortar setting beds for tile, Portland cement terrazzo, and other bonded applied cementitious finish flooring material, and as otherwise indicated.
1. After placing slabs, plane surface to tolerances for floor flatness (Ff) of 15 and floor levelness (Fl) of 13. Slope surfaces uniformly to drains where required. After leveling, roughen surface before final set with stiff brushes, brooms or rakes.
- B. Float Finish: Apply float finish to monolithic slab surfaces to receive trowel finish and other finishes as hereinafter specified; slab surfaces to be covered with membrane or elastic waterproofing membrane, elastic roofing, or sand-bed terrazzo; and as otherwise indicated.
1. After screeding, consolidating, and leveling concrete slabs, do not work surface until ready for floating. Begin floating, using float blades or float shoes only, when surface water has disappeared, when concrete has stiffened sufficiently to permit operation of power-driven floats, or both. Consolidate surface with power-driven floats or by hand-floating if area is small or inaccessible to power units. Check and level surface plane. Cut down high spots and fill low spots. Uniformly slope surfaces to drains. Immediately after leveling, re-float surface to a uniform, smooth, granular texture and a tolerance of Ff 20 - Fl 17.

- C. Trowel Finish: Apply trowel finish to monolithic slab surfaces to be exposed to view and slab surfaces to be covered with resilient flooring, carpet, ceramic or quarry tile, paint, or other thin film finish coating system.
 - 1. After floating, begin first trowel finish operation using a power-driven trowel. Begin final troweling when surface produces a ringing sound as trowel is moved over surface. Consolidate concrete surface by final hand-troweling operation, free of trowel marks, uniform in texture and appearance, and with surface leveled to tolerances of Ff 20 - Fl 17. Grind smooth surface defects that would telegraph through applied floor covering system.
- D. Trowel and Fine Broom Finish: Where ceramic or quarry tile is to be installed with thin-set mortar, apply trowel finish as specified, then immediately follow with slightly scarifying surface by fine brooming.
- E. Non-Slip Broom Finish: Apply non-slip broom finish to exterior concrete platforms, steps, and ramps, and elsewhere as indicated.
 - 1. Immediately after float finishing, slightly roughen concrete surface by brooming with fiber-bristle broom perpendicular to main traffic route. Coordinate required final finish with Architect before application.

3.11 CONCRETE CURING AND PROTECTION

- A. General: Protect freshly placed concrete from premature drying and excessive cold or hot temperatures. In hot, dry, and windy weather, protect concrete from rapid moisture loss before and during finishing operations with an evaporation-control material. Apply in accordance with manufacturer's instructions after screeding and bull floating, but before power floating and troweling.
 - 1. Start initial curing as soon as free water has disappeared from concrete surface after placing and finishing. Weather permitting, keep continuously moist for not less than 7 days.
- B. Curing Methods: Perform curing of concrete by curing and sealing compound, by moist curing, by moisture-retaining cover curing, and by combinations thereof, as herein specified.
 - 1. Provide moisture curing by following methods.
 - a. Keep concrete surface continuously wet by covering with water.
 - b. Use continuous water-fog spray.
 - c. Cover concrete surface with specified absorptive cover, thoroughly saturate cover with water, and keep continuously wet. Place absorptive cover to provide coverage of concrete surfaces and edges, with 4-inch lap over adjacent absorptive covers.
 - 2. Provide moisture-cover curing as follows:
 - a. Cover concrete surfaces with moisture-retaining cover for curing concrete, placed in widest practicable width with sides and ends lapped at least 3 inches and sealed by waterproof tape or adhesive. Immediately repair any holes or tears during curing period using cover material and waterproof tape.
 - 3. Provide curing and sealing compound to exposed interior slabs and to exterior slabs, walks, and curbs as follows:
 - a. Apply specified curing and sealing compound for all exposed interior slabs and trowelled slabs receiving mastic applied adhesives or "shake-on" hardeners. Exterior slabs, sidewalks, curbs and Architectural concrete not receiving a penetrating sealer, shall be cured with the specified clear, non-yellowing curing and sealing compound.

- b. Use membrane curing compounds that will not affect surfaces to be covered with finish materials applied directly to concrete.
- C. Curing Formed Surfaces: Cure formed concrete surfaces, including underside of beams, supported slabs, and other similar surfaces, by moist curing with forms in place for full curing period or until forms are removed. If forms are removed, continue curing by methods specified above, as applicable.
- D. Curing Unformed Surfaces: Cure unformed surfaces, such as slabs, floor topping, and other flat surfaces, by application of appropriate curing method.

3.12 REMOVAL OF FORMS

- A. General: Formwork not supporting weight of concrete, such as sides of beams, walls, columns and similar parts of the Work, may be removed after cumulatively curing at not less than 50 deg F for 24 hours after placing concrete, provided concrete is sufficiently hard to not be damaged by form-removal operations, and provided curing and protection operations are maintained.
 - 1. Formwork supporting weight of concrete, such as beam soffits, joists, slabs, and other structural elements, may not be removed in less than 7 days and until concrete has attained at least 75 percent of design minimum compressive strength at 28 days. Determine potential compressive strength of in-place concrete by testing field-cured specimens representative of concrete location or members.
 - 2. Form-facing material may be removed 4 days after placement only if shores and other vertical supports have been arranged to permit removal of form-facing material without loosening or disturbing shores and supports.

3.13 REUSE OF FORMS

- A. Clean and repair surfaces of forms to be re-used in Work. Split, frayed, delaminated, or otherwise damaged form-facing material will not be acceptable for exposed surfaces. Apply new form-coating compound as specified for new formwork.
- B. When forms are extended for successive concrete placement, thoroughly clean surfaces, remove fins and laitance, and tighten forms to close joints. Align and secure joint to avoid offsets. Do not use "patched" forms for exposed concrete surfaces except as acceptable to Architect.

3.14 MISCELLANEOUS CONCRETE ITEMS

- A. Filling In: Fill in holes and openings left in concrete structures for passage of Work by other trades, unless otherwise shown or directed, after Work of other trades is in place. Mix, place, and cure concrete as herein specified, to blend with in-place construction. Provide other miscellaneous concrete filling shown or required to complete Work.
- B. Curbs: Provide monolithic finish to interior curbs by stripping forms while concrete is still green and steel-troweling surfaces to a hard, dense finish with corners, intersections, and terminations slightly rounded.
- C. Equipment Bases and Foundations: Provide machine and equipment bases and foundations, as shown on drawings. Set anchor bolts for machines and equipment to template at correct elevations, complying with certified diagrams or templates of manufacturer furnishing machines and equipment.

3.15 CONCRETE SURFACE REPAIRS

- A. Patching Defective Areas: Repair and patch defective areas with cement mortar immediately after removal of forms, when acceptable to Architect.
1. Cut out honeycomb, rock pockets, voids over 1/4 inch in any dimension, and holes left by tie rods and bolts, down to solid concrete, but in no case to a depth of less than 1 inch. Make edges of cuts perpendicular to the concrete surface. Thoroughly clean, dampen with water, and brush-coat the area to be patched with specified bonding agent. Place patching mortar before bonding compound has dried or while the epoxy adhesive is still tacky.
 2. For exposed-to-view surfaces, blend white portland cement and standard portland cement so that, when dry, patching mortar will match color surrounding. Provide test areas at inconspicuous location to verify mixture and color match before proceeding with patching. Compact mortar in place and strike-off slightly higher than surrounding surface.
- B. Repair of Formed Surfaces: Remove and replace concrete having defective surfaces if defects cannot be repaired to satisfaction of Architect. Surface defects, as such, include color and texture irregularities, cracks, spalls, air bubbles, honeycomb, rock pockets, fins and other projections on surface, and stains and other discolorations that cannot be removed by cleaning. Flush out form tie holes, fill with dry-pack mortar, or pre-cast cement cone plugs secured in place with bonding agent.
1. Repair concealed formed surfaces, where possible, that contain defects that affect the durability of concrete. If defects cannot be repaired, remove and replace concrete.
- C. Repair of Unformed Surfaces: Test unformed surfaces, such as monolithic slabs, for smoothness and verify surface plane to tolerances specified for each surface and finish. Correct low and high areas as herein specified. Test unformed surfaces sloped to drain for trueness of slope and smoothness by using a template having required slope.
1. Repair finished unformed surfaces that contain defects that affect durability of concrete. Surface defects, as such, include crazing and cracks in excess of 0.01 inch wide or that penetrate to reinforcement or completely through non-reinforced sections regardless of width, spalling, pop-outs, honeycomb, rock pockets, and other objectionable conditions.
 2. Correct high areas in unformed surfaces by grinding after concrete has cured at least 14 days.
 3. Correct low areas in unformed surfaces during or immediately after completion of surface finishing operations by cutting out low areas and replacing with patching compound. Finish repaired areas to blend into adjacent concrete. The specified underlayment compound or repair topping may be used when acceptable to Architect.
 4. Repair defective areas, except random cracks and single holes not exceeding 1 inch in diameter, by cutting out and replacing with fresh concrete. Remove defective areas to sound concrete with clean, square cuts and expose reinforcing steel with at least 3/4-inch clearance all around. Dampen concrete surfaces in contact with patching concrete and apply bonding compound. Mix patching concrete of same materials to provide concrete of same type or class as original concrete. Place, compact, and finish to blend with adjacent finished concrete. Cure in same manner as adjacent concrete.
 5. Repair isolated random cracks and single holes not over 1 inch in diameter by dry-pack method. Groove top of cracks and cut out holes to sound concrete and clean of dust, dirt, and loose particles. Dampen cleaned concrete surfaces and apply bonding compound. Mix dry-pack, consisting of one part portland cement to 2- 1/2

parts fine aggregate passing a No. 16 mesh sieve, using only enough water as required for handling and placing. Place dry-pack before bonding compound has dried. Compact dry-pack mixture in place and finish to match adjacent concrete. Keep patched area continuously moist for not less than 72 hours.

6. All structural repairs shall be made with prior approval of the Architect, as to method and procedure, using the specified epoxy adhesive and/or epoxy mortar. Where epoxy injection procedures must be used, an approved low viscosity epoxy made by the manufacturers previously specified shall be used.
7. Leveling of floor for subsequent finishes shall be achieved by use of the specified underlayment material.
8. All exposed floors shall be leveled, where required, with the specified self-leveling repair topping.
9. Repair methods not specified above may be used, subject to acceptance of Architect.

END OF SECTION

SECTION 04200 - UNIT MASONRY

PART 1 - GENERAL

1.01 RELATED DOCUMENTS

- A. Drawings and general provisions of Contract, including General and Supplementary Conditions and Division 1 Specification Sections, apply to this Section.

1.02 SUMMARY

- A. Section includes:
 - 1. Clay Unit Masonry in the form of brick.
 - 2. Concrete Unit Masonry.
 - 3. Mortar
 - 4. Mortar trap
 - 5. Veneer ties
 - 6. Joint reinforcement
- B. Related Sections:
 - 1. Division 7 Section "Flashing and Sheet Metal" for exposed sheet metal flashing installed in masonry.
- C. Products installed but not furnished under this Section include the following:
 - 1. Wood nailers and blocking built into unit masonry are specified in Division 6 Section "Rough Carpentry".
 - 2. Reglets in masonry joints for metal flashing are specified in Division 7 Section "Flashing and Sheet Metal".
 - 3. Hollow metal frames in unit masonry openings are specified in Division 8 Section "Steel Doors and Frames".

1.03 SUBMITTALS

- A. Submit Manufacturer's Acknowledgement Letter. Follow Division 1 Section "Submittal Procedures."
- B. Submit Product Data. Include installation instructions, recommendations for each product, and data substantiating that materials comply with specified requirements.
- C. Submit samples for verification purposes of the following:
 - 1. Full-size units for each different exposed masonry unit required showing full range of exposed color, texture, and dimensions to be expected in completed construction.
 - 2. Include size variation data verifying that actual range of sizes for brick falls within ASTM C 216 dimension tolerances for brick where modular dimensioning is indicated.
 - 3. Colored masonry mortar samples for each color required showing the full range of colors expected in the finished construction. Label samples to indicate type and amount of colorant used.
 - 4. Accessories embedded in the masonry.

- D. Submit material certificates for the following signed by Manufacturer and Contractor certifying that each material complies with requirements.
 - 1. Each different cement product required for mortar and grout including name of manufacturer, brand, type, and weight slips at time of delivery.
 - 2. Each material and grade indicated for reinforcing bars.
 - 3. Each type and size of joint reinforcement.
 - 4. Each type and size of anchors, ties, and metal accessories.
- E. Submit material test reports from a qualified independent testing laboratory employed and paid by the Contractor indicating and interpreting test results relative to compliance of the following proposed masonry materials with requirements indicated:
 - 1. Mortar complying with property requirements of ASTM C 270.
 - 2. Grout mixes: Include description of type and proportions of grout ingredients.
 - 3. Masonry units.
 - 4. Cold-weather construction procedures evidencing compliance with requirements specified in referenced unit masonry standard.
 - 5. Hot-weather construction procedures evidencing compliance with requirements specified in referenced unit masonry standard.
 - 6. Qualification data for firms and persons specified in "Quality Assurance" Article to demonstrate their capabilities and experience. Include list of completed projects with project names, addresses, telephone numbers, names of Architects and Owners, and other information specified.
 - 7. Results from tests and inspections performed by Owner's representatives will be reported promptly and in writing to Architect and Contractor.

1.04 QUALITY ASSURANCE

- A. To qualify for employment in performing tests and inspection specified in this Section, an independent testing laboratory must demonstrate to Architect's satisfaction, based on evaluation of laboratory-submitted criteria conforming to ASTM C 1093, that it has the experience and capability to conduct satisfactorily the testing indicated without delaying the progress of the Work.
- B. Where indicated, provide materials and construction identical to those of assemblies whose fire resistance has been determined per ASTM E 119 by a testing and inspecting organization, by equivalent concrete masonry thickness, or by another means, as acceptable to authorities having jurisdiction.
- C. Obtain exposed masonry units of uniform texture and color, or a uniform blend within the ranges accepted for these characteristics, from one manufacturer for each different product required for each continuous surface or visually related surfaces.
- D. Obtain mortar ingredients of uniform quality, including color for exposed masonry, from one manufacturer for each cementitious component and from one source and producer for each aggregate.
- E. Prior to installation of unit masonry, erect sample wall panels to further verify selections made under sample submittals and to demonstrate aesthetic effects as well as qualities of materials and execution. Build mock-ups to comply with the following requirements using materials indicated for final unit of Work:
 - 1. Where masonry is to match existing, erect panels parallel to existing surface.

2. Notify Architect one week in advance of the dates and times when mock-ups will be erected.
3. Protect mock-ups from the elements with weather-resistant membrane.
4. Retain and maintain mock-ups during construction in undisturbed condition as standard for judging completed unit masonry construction.
5. When directed, demolish and remove mock-ups from Project site.

1.05 DELIVERY, STORAGE, AND HANDLING

- A. Deliver masonry materials to project in undamaged condition.
1. Store and handle masonry units off the ground, undercover, and in a dry location to prevent their deterioration or damage due to moisture, temperature changes, contaminants, corrosion, and other causes. If units become wet, do not place until units are in an air-dried condition.
 2. Store cementitious materials off the ground, under cover, and in dry location.
 3. Store aggregates where grading and other required characteristics can be maintained and contamination avoided.
 4. Store masonry accessories including metal items to prevent corrosion and accumulation of dirt and oil.

1.06 PROJECT CONDITIONS

- A. During erection, cover tops of walls, projections, and sills with waterproof sheeting at end of each day's work. Cover partially completed masonry when construction is not in progress.
1. Extend cover a minimum of 24 inches down both sides and hold cover securely in place.
 2. Where one wythe of multiwythe masonry walls is completed in advance of other wythes, secure cover a minimum of 24 inches down face next to unconstructed wythe and hold cover in place.
- B. Prevent grout, mortar, and soil from staining the face of masonry to be left exposed or painted. Remove immediately any grout, mortar, and soil that come in contact with such masonry.
1. Protect base of walls from rain-splashed mud and mortar splatter by means of coverings spread on ground and over wall surface.
 2. Protect sills, ledges, and projections from mortar droppings.
 3. Protect surfaces of window and door frames, as well as similar products with painted and integral finishes from mortar droppings.
- C. Comply with referenced unit masonry standard for cold-weather construction and the following:
1. Do not lay masonry units that are wet or frozen.
 2. Remove masonry damaged by freezing conditions.
- D. Hot-Weather Construction: Comply with referenced unit masonry standard.

PART 2 - PRODUCTS

2.01 MATERIALS, GENERAL

- A. Comply with referenced unit masonry standard and other requirements specified in this Section applicable to each material indicated.

2.02 CLAY MASONRY UNITS

- A. Comply with the following requirements applicable to each form of clay masonry unit required:
 - 1. Face Brick Standard: ASTM C 216.
 - a. Brick selection as shown on Drawings.

2.03 CONCRETE MASONRY UNITS

- A. Comply with requirements indicated below applicable to each form of concrete masonry unit required.
 - 1. Provide special shapes where indicated and as follows:
 - a. For lintels, corners, jambs, sash, control joints, headers, bonding, and other special conditions.
 - b. Bullnose units for outside corners unless otherwise indicated.
- B. Section includes integral water-repellent admixture for concrete masonry units.
- C. Provide concrete masonry units complying with requirements indicated below for size that are manufactured to specified face dimensions within tolerances specified in the applicable referenced ASTM specification for concrete masonry units.
 - 1. Concrete Masonry Units: Manufactured to specified dimensions of 3/8 inch less than nominal widths by nominal heights by nominal lengths indicated on drawings.
 - 2. Provide Type I, moisture-controlled units.
 - 3. Exposed Faces: Manufacturer's standard color and texture, unless otherwise indicated.
- D. Hollow Load-Bearing Concrete Masonry Units: ASTM C 90, Grade N and as follows:
 - 1. Provide units with minimum average net area compressive strength indicated below:
 - a. 1,900 psi.
 - b. Not less than the unit compressive strengths required to produce concrete unit masonry construction of compressive strength indicated.
 - 2. Weight Classification: Medium weight.
- E. Integral Water Repellent: Provide units made with liquid polymeric, integral water-repellent admixture that does not reduce flexural bond strength. Units made with integral water repellent, when tested as a wall assembly made with mortar containing integral water-repellent manufacturer's mortar additive according to ASTM E 514, with test period extended to 24 hours, show no visible water or leaks on the back of the test specimen.
 - 1. Subject to compliance with requirements, provide one of the following:
 - a. Block Plus W-10; Addiment Inc.
 - b. Dry-Block; W. R. Grace & Co., Construction Products Division.

- c. Rheopel; Master Builders.

2.04 PREGLAZED CONCRETE MASONRY UNITS

- A. Manufacturer shall be licensed or authorized in writing by The Spectra Group through Spectra Industrial Licensing Corporation, Baltimore, Maryland.
 - 1. Alternate products will be considered.
- B. Facing ingredients shall be Spectra-Glaze Compound made with Spectra-Glaze polymers, supplied to approved manufacturers by Spectra Materials Corporation, a Spectra Sciences, LLC Company, and other ingredients as required to meet or exceed Spectra-Glaze Block product standards including ASTM C 744.
- C. Pre-faced surfaces for interior use shall be smooth, colored satin finish conforming to the most up-to-date official Spectra-Glaze product standards published by Spectra Industrial Licensing Corporation and the Spectra Group and ASTM C 744.
- D. Pre-faced surfaces for exterior use shall be smooth, satin finish, conforming to ASTM C 744, ASTM C 67, paragraph 8 (freeze-thaw) and Thermal Shock Test B100JL, 24P.
- E. Colors shall be selected from Manufacturer's established or custom colors. All Standard, Vari-tone, or Special Colors Series shall conform to ASTM C 744.
- F. Surface Burning Characteristics of Facing: ASTM E 84; flame spread less than 25; fuel contribution 0; smoke density less than 50. Products of combustion considered non-toxic as determined by BRC 4690 (toxicity testing).
- G. Unit Sizes & Joints: as shown on Drawings.
- H. Concrete Block for Glazing: ASTM C 90 for hollow and solid load-bearing units; Type 1 (moisture controlled) for exterior use requires Block-Rite integral efflorescence control system.
- I. Provide shapes to suit the condition shown.
- J. Jointing Tools: Use glass 5/8" for concave joints; clean, non-staining metal tools elsewhere. Replace worn tools promptly.
- K. Integral Water Repellent: Provide units made with liquid polymeric, integral water-repellent admixture that does not reduce flexural bond strength. Units made with integral water repellent, when tested as a wall assembly made with mortar containing integral water-repellent manufacturer's mortar additive according to ASTM E 514, with test period extended to 24 hours, show no visible water or leaks on the back of the test specimen.
 - 1. Subject to compliance with requirements, provide one of the following:
 - a. Block Plus W-10; Addiment Inc.
 - b. Dry-Block; W. R. Grace & Co., Construction Products Division.
 - c. Rheopel; Master Builders.

2.05 MORTAR AND GROUT MATERIALS

- A. Portland Cement: ASTM C 150, Type II, except Type III may be used for cold-weather construction. Provide white cement to produce required mortar color.
- B. Ready-Mixed Mortar: Cementitious materials, water, and aggregate complying with requirements specified in this article, combined with set-controlling admixtures to produce a ready-mixed mortar complying with ASTM C 1142.
- C. Hydrated Lime: ASTM C 207, Type S.

- D. Water: Clean and potable.
- E. Aggregate for Mortar: ASTM C 144, except for joints less than 1/4 inch use aggregate graded with 100 percent passing the No. 16 sieve.
- F. Aggregate for Grout: ASTM C 404.
- G. Colored Mortar Pigments: Natural and synthetic iron oxides and chromium oxides, compounded for use in mortar mixes. Use only pigments with record of satisfactory performance in masonry mortars.
- H. Color shall be as selected by Architect. Contractor shall include in the Bid the Cost related to "light" colored mortar using white cement.
- I. Subject to compliance with requirements, products that may be incorporated in the Work include, but are not limited to, the following:
 - 1. Colored Mortar Pigments:
 - a. "Centurion Pigments," Centurion.
 - b. "True Tone Mortar Colors," Davis Colors, a Subsidiary of Rockwood Industries, Inc.
 - c. "SGS Mortar Colors," Solomon Grind-Chem Services, Inc.

2.06 REINFORCING STEEL

- A. Provide reinforcing steel complying with requirements of referenced unit masonry standard and this article.
- B. Steel Reinforcing Bars: Material and grade as follows:
 - 1. Grade 40 for No. 3 Bars and Grade 60 for all others.

2.07 MORTAR TRAP

- A. High-density polyethylene panels which trap mortar but allow water to flow freely to weeps.
- B. Size: 10" high x maximum length available
- C. Thickness: Maximum width available to fit cavity.
- D. Acceptable manufacturer/product:
 - 1. Hohmann and Barnard "Mortar Trap"
 - 2. Mortar Net Solutions "Mortar Net"

2.08 JOINT REINFORCEMENT

- A. Provide joint reinforcement complying with requirements of referenced unit masonry standard and this article, formed from the following:
 - 1. Galvanized carbon steel wire, coating class as required by referenced unit masonry standard for application indicated.
- B. Welded-wire units shall be prefabricated with deformed continuous side rods and plain cross rods into straight lengths of not less than 10 feet, with prefabricated corner and tee units, and complying with requirements indicated below:
 - 1. Wire Diameter for Side Rods: 0.1483 inch (9 gauge).
 - 2. Wire Diameter for Cross Rods: 0.1483 inch (9 gauge).
 - 3. Wire Diameter for Cross Rods: 0.1875 inch.
 - 4. For single-wythe masonry provide type as follows with single pair of side rods:

- a. Truss design with continuous diagonal cross rods spaced not more than 16 inches o.c.
- 5. For multiwythe masonry provide type as follows:
 - a. Ladder design with perpendicular cross rods spaced not more than 16 inches o.c. and number of side rods as follows:
 - (1) For Multiwythe Concrete Masonry: One side rod for each face shell of hollow masonry units more than 4 inches in nominal width plus one side rod for each wythe of masonry 4 inches or less in nominal width.
 - (2) Tab design with single pair of side rods and rectangular box-type cross ties spaced not more than 16 inches o.c.; with side rods spaced for embedment within each face shell of backup wythe and ties extended to engage the outer wythe by at least 1-1/2 inches.
 - (3) Use units with adjustable 2-piece rectangular ties where horizontal joints of facing wythe do not align with those of backup by more than and where indicated.
- C. Subject to compliance with requirements, manufacturers offering joint reinforcement that may be incorporated in the Work include, but are not limited to, the following:
 - 1. AA Wire Products Co.
 - 2. Dur-O-Wal, Inc.
 - 3. Heckman Building Products, Inc.
 - 4. Hohmann & Barnard, Inc.
 - 5. National Wire Products Industries.

2.09 TIES AND ANCHORS, GENERAL

- A. Provide ties and anchors specified in subsequent articles that comply with requirements for metal and size of referenced unit masonry standard and of this article.
- B. Galvanized Carbon Steel Wire: ASTM A 82, coating class as required by referenced unit masonry standard for application indicated.
- C. Wire Diameter: 0.1875 inch.
- D. Galvanized Steel Sheet: As follows:
 - 1. ASTM A 526 (commercial quality), Coating Designation G60, steel sheet zinc-coated by hot-dip process on continuous lines prior to fabrication, for sheet metal ties and anchors completely embedded in mortar.
 - a. Galvanized Steel Sheet Thickness: For steel sheet hot-dip galvanized by continuous process prior to fabrication:
 - (1) 0.0635 inch (16 gauge).
 - (2) 0.0785 inch (14 gauge).
 - (3) 0.1084 inch (12 gauge).
- E. Subject to compliance with requirements, manufacturers offering products that may be incorporated in the Work include, but are not limited to the following:
 - 1. AA Wire Products Co.
 - 2. Dur-O-Wal, Inc.
 - 3. Heckman Building Products, Inc.

4. Hohmann & Barnard, Inc.
5. National Wire Products Industries.

2.10 BENT WIRE TIES

- A. Individual units prefabricated from bent wire to comply with requirements indicated below:
1. Tie Shape for Hollow Masonry Units Laid with Cells Vertical: Rectangular with closed ends and not less than 4 inches wide.
 2. Type for Masonry Where Coursing Between Wythes Align: Unit ties bent from one piece of wire.
 3. Type for Masonry Where Coursing Between Wythes Does Not Align: Adjustable ties composed of two parts, one with pintles, the other with eyes, maximum misalignment 1-1/4 inches.

2.11 WEEPS

- A. Aluminum weep hole
1. Painted aluminum, with louvers.
 2. Color: grey
 3. Size: 2-1/4" high
 4. Acceptable manufacturer/product (or approved alternate):
 - a. Hohmann and Barnard #343W

2.12 EMBEDDED FLASHING MATERIALS

- A. Sheet Metal Flashing and Reglets: Fabricate from the following metal complying with requirements specified in Division 7 Section "Flashing and Sheet Metal" and below:
1. Fabricate reglets and through-wall metal flashings embedded in masonry as follows:
 - a. With ribs formed in dovetail pattern at 3-inch intervals along length of flashing to provide a three-way integral mortar bond and weep-hole drainage.
 - b. With ribs formed in sawtooth pattern at 3-inch intervals along length of flashing to provide a three-way integral mortar bond and weep-hole drainage.
 2. Fabricate metal expansion joint strips from sheet metal indicated above, formed to shape indicated.
 3. Solder and Sealants for Sheet Metal Flashings: As specified in Division 7 section "Flashing and Sheet Metal."
 4. Application: Use where flashing is fully or partly concealed in masonry wall.
- B. Flexible Laminated Flashing: Manufacturer's standard laminated flashing of type indicated below:
1. Asphalt-Coated Copper Flashing: Manufacturer's standard product consisting of sheet copper of weight per sq. ft. indicated below coated with flexible asphalt.
 - a. Weight: 5 oz.
 2. Application: Use where flexible flashing is fully concealed in masonry, lintels, through wall applications.

3. Available Products: Subject to compliance with requirements, asphalt-coated copper flashing that may be incorporated in the Work include, but are not limited to, the following:
 - a. "Cop-A-Cote," Afco Products Inc.
 - b. "Type ACC-Asphalt Bituminous Coated," Phoenix Building Products.
"Coated Copper Flashing," Sandell Manufacturing Co., Inc.
 - c. "Copperseal," York Manufacturing, Inc.

2.13 MISCELLANEOUS MASONRY ACCESSORIES

- A. Nonmetallic Expansion Joint Strips: Premolded filler strips complying with ASTM D 1056, Type 2 (closed cell), Class A (cellular rubber and rubber-like materials with specific resistance to petroleum base oils), Grade 1 (compression-deflection range of 2-5 psi), compressible up to 35 percent, of width and thickness indicated, formulated from the following material:
 1. Neoprene.
- B. Preformed Control Joint Gaskets: Material as indicated below, designed to fit standard sash block and to maintain lateral stability in masonry wall; size and configuration as indicated.
 1. Styrene-Butadiene Rubber Compound: ASTM D 2000, Designation 2AA-805.
- C. Bond Breaker Strips: Asphalt-saturated organic roofing felt complying with ASTM D 226, Type I (No. 15 asphalt felt).

2.14 MASONRY CLEANERS

- A. Proprietary Acidic Cleaner: Manufacturer's standard-strength, general-purpose cleaner designed for removing mortar/grout stains, efflorescence, and other new construction stains from new masonry surfaces of type indicated below without discoloring or damaging masonry surfaces; expressly approved for intended use by manufacturer of masonry units being cleaned:
 1. For masonry not subject to metallic oxidation stains, use formulation consisting of a concentrated blend of surface-acting acids, chelating, and wetting agents.
 2. Available Products: Subject to compliance with requirements, a product that may be used to clean unit masonry surfaces includes, but is not limited to, the following:
 - a. "Sure Klean No. 600 Detergent," ProSoCo, Inc.

2.15 MORTAR AND GROUT MIXES

- A. Do not add admixtures including coloring pigments, air-entraining agents, accelerators, retarders, water repellent agents, antifreeze compounds, or other admixtures, unless otherwise indicated.
 1. Do not use calcium chloride in mortar or grout.
- B. Mortar for Unit Masonry: Comply with ASTM C 270, Property Specification for job-mixed mortar and ASTM C 1142 for ready-mixed mortar, of types indicated below:
 1. Limit cementitious materials in mortar to portland cement-lime.
 2. For masonry below grade and in contact with earth, and where indicated, use type indicated below:
 - a. Type S.
 3. For reinforced masonry and where indicated, use type indicated below:

- a. Type S.
- 4. For exterior, above-grade load-bearing and nonload-bearing walls and parapet walls; for interior loadbearing walls; for interior nonloadbearing partitions, and for other applications where another type is not indicated, use type indicated below:
 - a. Type N.
- C. Colored Pigmented Mortar: Select and proportion pigments with other ingredients to produce color required.
- D. Grout for Unit Masonry: Comply with ASTM C 476 and referenced unit masonry standard.

2.16 SOURCE QUALITY CONTROL

- A. Brick Tests: For each type and grade of brick indicated, units will be tested by qualified independent testing laboratory per ASTM C 67 except 5 bricks will be selected at random for each 100,000 units or fraction thereof installed.
- B. Concrete Masonry Unit Tests: For each type, class, and grade of concrete masonry unit indicated, units will be tested by qualified independent testing laboratory for strength, absorption, and moisture content per ASTM C 140.

PART 3 - EXECUTION

3.01 EXAMINATION

- A. Examine conditions, with Installer present, for compliance with requirements for installation tolerances and other specific conditions, and other conditions affecting performance of unit masonry.
 - 1. For the record, prepare written report, endorsed by Installer, listing conditions detrimental to performance of unit masonry.
 - 2. Examine rough-in and built-in construction to verify actual locations of piping connections prior to installation.

3.02 INSTALLATION, GENERAL

- A. Comply with referenced unit masonry standard and other requirements indicated applicable to each type of installation included in Project.
 - 1. Build cavity and composite walls and other masonry construction to the full thickness shown. Build single-wythe walls to the actual thickness of the masonry units, using units of nominal thickness indicated.
 - 2. Build chases and recesses as shown or required to accommodate items specified in this and other Sections of the Specifications. Provide not less than 8 inches of masonry between chase or recess and jamb of openings and between adjacent chases and recesses.
 - 3. Leave openings for equipment to be installed before completion of masonry. After installation of equipment, complete masonry to match construction immediately adjacent to the opening.
 - 4. Cut masonry units with motor-driven saws to provide clean, sharp, unchipped edges. Cut units as required to provide continuous pattern and to fit adjoining construction. Use full-size units without cutting where possible.

3.03 CONSTRUCTION TOLERANCES

- A. Comply with construction tolerances of Brick Institute of America and the National Concrete Masonry Association.

3.04 LAYING MASONRY WALLS

- A. Lay out walls in advance for accurate spacing of surface bond patterns with uniform joint widths and for accurate locating of openings, movement-type joints, returns, and offsets. Avoid the use of less than half size units at corners, jambs, and where possible at other locations.
 - 1. Lay up walls to comply with specified construction tolerances, with courses accurately spaced and coordinated with other construction.
- B. Bond Pattern for Exposed Masonry: Lay exposed masonry in the following bond pattern; do not use units with less than nominal 4-inch horizontal face dimensions at corners or jambs.
 - 1. Running 1/2 bond.
 - 2. Lay concealed masonry with all units in a wythe in running bond or bonded by lapping not less than 2 inches. Bond and interlock each course of each wythe at corners. Do not use units with less than nominal 4-inch horizontal face dimensions at corners or jambs.
- C. Stopping and Resuming Work: In each course, rack back 1/2-unit length for one-half running bond or 1/3-unit length for one-third running bond; do not tooth. Clean exposed surfaces of set masonry, wet clay masonry units lightly (if required), and remove loose masonry units and mortar prior to laying fresh masonry.
- D. Built-In Work: As construction progresses, build-in items specified under this and other Sections of the Specifications. Fill in solidly with masonry around built-in items.
 - 1. Fill space between hollow metal frames and masonry solidly with mortar, unless otherwise indicated.
 - 2. Where built-in items are to be embedded in cores of hollow masonry units, place a layer of metal lath in the joint below and rod mortar or grout into core.
 - 3. Fill cores in hollow concrete masonry units with grout 3 courses (24 inches) under bearing plates, beams, lintels, posts, and similar items, unless otherwise indicated.

3.05 MORTAR BEDDING AND JOINTING

- A. Typical joint profile: concave.
- B. Lay hollow concrete masonry units as follows:
 - 1. With full mortar coverage on horizontal and vertical face shells.
 - 2. Bed webs in mortar in starting course on footings and in all courses of piers, columns, and pilasters, and where adjacent to cells or cavities to be filled with grout.
 - 3. Cut joints flush for masonry walls to be concealed or to be covered by other materials, unless otherwise indicated.
- C. Lay hollow brick as follows:
 - 1. Lay vertical cell units with full head joints, unless otherwise noted. Provide full bed mortar coverage on face shells and webs.

2. Maintain joint widths indicated, except for minor variations required to maintain bond alignment. If not indicated, lay walls with 3/8 inch joints.

3.06 CAVITIES/AIR SPACES

- A. Keep cavities/air spaces clean of mortar droppings and other materials during construction. Strike joints facing cavities/air spaces flush.
 1. Tie exterior wythe to backup with specified ties or anchors.

3.07 HORIZONTAL JOINT REINFORCEMENT

- A. Provide continuous horizontal joint reinforcement as indicated. Install longitudinal side rods in mortar for their entire length with a minimum cover of 5/8 inch on exterior side of walls, 1/2 inch elsewhere. Lap reinforcing a minimum of 6 inches.
 1. Cut or interrupt joint reinforcement at control and expansion joints, unless otherwise indicated.
 2. Provide continuity at corners and wall intersections by use of prefabricated "L" and "T" sections. Cut and bend reinforcement units as directed by manufacturer for continuity at returns, offsets, column fireproofing, pipe enclosures, and other special conditions.

3.08 ANCHORING SINGLE-WYTHE MASONRY VENEER

- A. Anchor single-wythe masonry veneer to metal studs with masonry veneer anchors to comply with the following requirements:
 1. Fasten each anchor section through sheathing to wood or metal studs with 2 metal fasteners of type indicated.
 2. Embed tie section in masonry joints. Provide not less than 2-inch air space between back of masonry veneer wythe and face of sheathing.
 3. Locate anchor section relative to course in which tie section is embedded to allow maximum vertical differential movement of tie up and down.
 4. Space anchors as indicated but not more than 24 inches o.c. vertically and 16 inches o.c. horizontally with not less than one anchor for each 2 sq. ft. of wall area. Install additional anchors within 1'-0" of openings and at intervals around perimeter not exceeding 8 inches.

3.09 MOVEMENT (CONTROL AND EXPANSION) JOINTS

- A. Install control and expansion joints in unit masonry where indicated. Build in related items as the masonry progresses. Do not form a continuous span through movement joints unless provisions are made to prevent in-plane restraint of wall or partition movement.
- B. Form control joints in concrete masonry as follows:
 1. Fit bond breaker strips into hollow contour in ends of block units on one side of control joint. Fill the resultant core with grout and rake joints in exposed faces.
 2. Install preformed control joint gaskets designed to fit standard sash block.
 3. Install special shapes designed for control joints. Install bond breaker strips at joint. Keep head joints free and clear of mortar or rake joint.
- C. Form expansion joints in brick made from clay or shale as follows:
 1. Build in joint fillers where indicated.

2. Form open joint of width indicated but not less than 3/8 inch for installation of sealant and backer rod specified in Division 7 Section "Joint Sealers." Maintain joint free and clear of mortar.

3.10 FLASHING/WEEP HOLES

- A. Install embedded flashing and weep holes in masonry at shelf angles, lintels, ledges, other obstructions to the downward flow of water in the wall, and where indicated.
- B. Prepare masonry surfaces so that they are smooth and free from projections that could puncture flashing. Place through-wall flashing on sloping bed of mortar and cover with mortar. Seal penetrations in flashing with adhesive/sealant/tape as recommended by flashing manufacturer before covering with mortar.
- C. Install flashings as follows:
 1. At lintels and shelf angles, extend flashing a minimum of 4 inches into masonry at each end. Extend flashing from exterior face of outer wythe of masonry, through the outer wythe, turned up a minimum of 4 inches, and through the inner wythe to within 1/2 inches of the interior face of the wall in exposed masonry. Where interior surface of inner wythe is concealed by furring, carry flashing completely through the inner wythe and turn up approximately 2 inches, unless otherwise indicated.
 2. At heads and sills, extend flashing as specified above unless otherwise indicated but turn up ends not less than 2 inches to form a pan.
 3. Install flashing in masonry veneer walls as specified above but carry flashing up face of sheathing at least 8 inches.
- D. Install weep holes in the head joints in exterior wythes of the first course of masonry immediately above embedded flashings and as follows:
 1. Form weep holes by keeping head joints free and clear of mortar.
 2. Space weep holes as shown on the drawings.
- E. Install reglets and nailers for flashing and other related construction where shown to be built into masonry.

3.11 INSTALLATION OF REINFORCED UNIT MASONRY

- A. Install reinforced unit masonry to comply with requirements of referenced unit masonry standard.
- B. Temporary Formwork: Construct formwork and shores to support reinforced masonry elements during construction.
 1. Construct formwork to conform to shape, line, and dimensions shown. Make sufficiently tight to prevent leakage of mortar and grout. Brace, tie, and support forms to maintain position and shape during construction and curing of reinforced masonry.
 2. Do not place grout until entire height of masonry to be grouted has attained sufficient strength to resist grout pressure.
 3. Do not remove forms and shores until reinforced masonry members have hardened sufficiently to carry their own weight and other temporary loads that may be placed on them during construction.

3.12 FIELD QUALITY CONTROL

- A. Testing Frequency: Tests and evaluations listed in this article will be performed during construction for each 5000 sq. ft. of wall area or portion thereof.
 - 1. Mortar properties will be tested per property specification of ASTM C 270.
 - 2. Mortar composition and properties will be evaluated per ASTM C 780.
 - 3. Grout compressive strength will be sampled and tested per ASTM C 1019.
- B. Evaluation of Quality Control Tests: In absence of other indications of noncompliance with requirements, masonry will be considered satisfactory if results from construction quality control tests comply with minimum requirements indicated.

3.13 REPAIRING, POINTING, AND CLEANING

- A. Remove and replace masonry units that are loose, chipped, broken, stained, or otherwise damaged or if units do not match adjoining units. Install new units to match adjoining units and in fresh mortar or grout, pointed to eliminate evidence of replacement.
- B. Pointing: During the tooling of joints, enlarge any voids or holes, except weep holes, and completely fill with mortar. Point-up all joints including corners, openings, and adjacent construction to provide a neat, uniform appearance, prepared for application of sealants.
- C. Final Cleaning: After mortar is thoroughly set and cured, clean exposed masonry as follows:
 - 1. Remove large mortar particles by hand with wooden paddles and nonmetallic scrape hoes or chisels.
 - 2. Test cleaning methods on sample wall panel; leave 1/2 panel uncleaned for comparison purposes. Obtain Architect's approval of sample cleaning before proceeding with cleaning of masonry.
 - 3. Protect adjacent stone and non-masonry surfaces from contact with cleaner by covering them with liquid strippable masking agent, polyethylene film, or waterproof masking tape.
 - 4. Wet wall surfaces with water prior to application of cleaners; remove cleaners promptly by rinsing thoroughly with clear water.
 - 5. Clean brick by means of bucket and brush hand-cleaning method described in BIA "Technical Note No. 20 Revised" using the following masonry cleaner:
 - a. Proprietary acidic cleaner; apply in compliance with directions of acidic cleaner manufacturer.
 - 6. Clean concrete masonry by means of cleaning method indicated in NCMA TEK 45 applicable to type of stain present on exposed surfaces.
- D. Provide final protection and maintain conditions, in a manner acceptable to Installer, that ensure unit masonry is without damage and deterioration at time of Substantial Completion.

END OF SECTION

SECTION 05400 - COLD-FORMED METAL FRAMING

PART 1 - GENERAL

1.01 RELATED DOCUMENTS

- A. Documents and general provisions of Contract, including General and Supplementary Conditions and Division 1 Specification Sections, apply to this Section.

1.02 SUMMARY

- A. Section includes C-shaped load-bearing steel studs and track.
- B. Related Sections include Division 9 Section "Gypsum Board Assemblies" for non-load bearing and interior steel studs.

1.03 SUBMITTALS

- A. Submit manufacturer's acknowledgement letter. Follow Division 1 Section "Submittal Procedures."
- B. Submit Manufacturer's Technical Product Data, installation instructions, and recommendations for each product. Include data substantiating that materials comply with specified requirements and installation instructions for each item of cold-formed metal framing and accessories.
- C. Submit shop drawings for special components and installations not fully dimensioned or detailed in manufacturer's product data.
 - 1. Include placing drawings for framing members showing size and gauge designations, number, type, location, and spacing. Indicate supplemental strapping, bracing, splices, bridging, accessories, and details required for proper installation.
 - 2. Indicate component details, framed openings, bearing, anchorage, loading, welds, type and location of fasteners, and accessories or items required of related work.
 - 3. Indicate stud layout.
 - 4. Describe method for securing studs to tracks for bolted or welded framing connections.
 - 5. Provide calculations for loadings and stresses of specialty fabricated framing under the seal of a Professional Structural Engineer registered in the state of Texas.

1.04 QUALITY ASSURANCE

- A. Calculate structural properties of studs and joists in accordance with American Iron and Steel Institute (AISI) "Specification for Design of Cold-Formed Steel Structural Members", MFMA – Guidelines for the use of metal Framing and AWS D1.3 requirements.
 - 1. Maximum allowable deflection: 1:600 of span.
 - 2. Form, fabricate, install and connect components in accordance with ML/SFA 540 – Lightweight Steel Framing Systems manual.

- B. Welding: Use qualified welders and comply with American Welding Society (AWS) D1.3, "Structural Welding Code - Sheet Steel."

PART 2 - PRODUCTS

2.01 MANUFACTURERS

- A. Available Manufacturers: Subject to compliance with requirements, manufacturers offering products that may be incorporated in the Work include, but are not limited to the following:
 - 1. Alabama Metal Industries Corp.
 - 2. Dale Industries, Inc.
 - 3. Dietrich Industries, Inc.
 - 4. Marino Industries, Inc.
 - 5. Superior Steel Studs, Inc.
 - 6. United States Steel.
 - 7. Wheeling Corrugating Co.

2.02 METAL FRAMING

- A. Furnish manufacturers' standard load-bearing steel studs of type, size, shape, and gauge as indicated. With each type of metal framing required, provide manufacturer's standard steel runners (tracks), blocking, lintels, clip angles, shoes, reinforcements, fasteners, and accessories for applications indicated, as needed to provide a complete metal framing system.
- B. For 16-gauge and heavier units, fabricate metal framing components of structural quality steel sheet with a minimum yield point of 40,000 psi; ASTM A 446, A 570, or A 611.
 - 1. For 18-gauge and lighter units, fabricate metal framing components of commercial quality steel sheet with a minimum yield point of 33,000 psi; ASTM A 446, A 570, or A 611.
 - 2. Provide galvanized finish to metal framing components complying with ASTM A 525 for minimum G 60 coating.
- C. Provide nuts, bolts, washers, screws, and other fasteners with corrosion-resistant plated finish.
- D. Electrodes for welding shall comply with AWS Code and as recommended by stud manufacturer.
- E. Where galvanized surfaces are damaged, prepare surfaces and repair in accordance with procedures specified in ASTM A 780.

2.03 FABRICATION

- A. Framing components may be prefabricated into assemblies before erection. Fabricate panels plumb, square, true to line, and braced against racking with joints welded. Perform lifting of prefabricated units to prevent damage or distortion.
 - 1. Fabricate units in jig templates to hold members in proper alignment, position and to assure consistent component placement.
- B. Attach similar components by welding. Attach dissimilar components by welding, bolting, or screw fasteners, as standard with manufacturer.
 - 1. Wire tying of framing components is not permitted.

- C. Fabricate units to a maximum allowable tolerance variation from plumb, level, and true to line of 1/8 inch in 10 feet.

2.04 MISCELLANEOUS MATERIALS

- A. Sill-Sealer gaskets shall be closed-cell neoprene foam, 3/16 inch thick, selected from manufacturer's standard widths to suit width of sill members indicated.
 - 1. Use widest width possible which will not exceed width of sill.
 - 2. Acceptable manufacturer/product (or approved alternate): Owens Corning "FoamSealR"

PART 3 - EXECUTION

3.01 INSTALLATION

- A. Install metal framing systems in accordance with manufacturer's printed or written instructions and recommendations.
- B. Install continuous runner tracks sized to match studs. Align tracks accurately to layout at base and tops of studs. Secure tracks as recommended by stud manufacturer for type of construction involved and as shown on the Structural Drawings, except do not exceed 24 inches o.c. spacing for nail or power-driven fasteners or 16 inches o.c. for other types of attachment. Provide fasteners at corners and ends of tracks.
- C. Secure studs to top and bottom runner tracks by either welding or screw fastening at both inside and outside flanges.
 - 1. Set studs plumb, except as needed for diagonal bracing or required for nonplumb walls or warped surfaces and similar requirements.
 - 2. Where stud system abuts structural columns or walls, including masonry walls, anchor ends of stiffeners to supporting structure.
 - 3. Install supplementary framing, blocking, and bracing in metal framing system wherever walls or partitions are indicated to support fixtures, equipment, services, casework, heavy trim and furnishings, and similar Work requiring attachment to the wall or partition. Where type of supplementary support is not otherwise indicated, comply with stud manufacturer's recommendations and industry standards in each case, considering weight or loading resulting from item supported.
 - 4. Frame wall openings larger than 2 feet square with double stud at each jamb of frame except where more than two are either shown or indicated in manufacturer's instructions. Install runner tracks and jack studs above and below wall openings. Anchor tracks to jamb studs with stud shoes or by welding, and space jack studs same as full-height studs of wall. Secure stud system wall opening frame in manner indicated.
 - 5. Frame both sides of expansion and control joints with separate studs; do not bridge the joint with components of stud system.
 - 6. Install horizontal stiffeners in stud system, spaced (vertical distance) at not more than 54 inches o.c. Weld at each intersection.
- D. Erection Tolerances:
 - 1. Bolt or weld wall panels (at both horizontal and vertical junctures) to produce flush, even, true-to-line joints.

2. Maximum variation in plane and true position between prefabricated assemblies should not exceed 1/16 inch.
- E. Touch-up damaged shop-applied protective coatings. Use compatible primer for prime-coated surfaces; use galvanized repair system for galvanized surfaces.

END OF SECTION

SECTION 05500 - METAL FABRICATIONS

PART 1 - GENERAL

1.01 RELATED DOCUMENTS

- A. Drawings and general provisions of the Contract, including General and Supplementary Conditions and Division 1 Specification Sections, apply to this Section.

1.02 SUMMARY

- A. Section includes:
 - 1. Pipe bollards.
- B. Related Sections:
 - 1. Division 5 Section "Galvanizing".

1.03 QUALITY ASSURANCE

- A. Fabricator shall be a firm experienced in producing metal fabrications similar to those indicated for this Project and with a record of successful in-service performance, as well as sufficient production capacity to produce required units.
- B. Qualify welding procedures and personnel according to the following:
 - 1. AWS D1.1, "Structural Welding Code--Steel."
 - 2. Certify that each welder has satisfactorily passed AWS qualification tests for welding processes involved and, if pertinent, has undergone recertification.

PART 2 - PRODUCTS

2.01 METALS

- A. Metal Surfaces, General: For metal fabrications exposed to view in the completed Work, provide materials with smooth, flat surfaces without blemishes. Do not use materials with exposed pitting, seam marks, roller marks, rolled trade names, or roughness.
- B. Ferrous Metals:
 - 1. Steel Pipe: ASTM A 53, standard weight (Schedule 40), unless another weight is indicated or required by structural loads.
- C. Welding Rods and Bare Electrodes: Select according to AWS specifications for metal alloy welded.

2.02 PAINT

- A. Galvanizing Repair Paint: High-zinc-dust-content paint for regalvanizing welds in steel, complying with SSPC-Paint 20.

2.03 CONCRETE FILL

- A. Concrete Materials and Properties: Comply with requirements in Division 3 Section "Cast-in-Place Concrete" for normal-weight, air-entrained, ready-mix concrete with a minimum 28-day compressive strength of 3000 psi, unless otherwise indicated.

2.04 FABRICATION

- A. Preassemble items in shop to greatest extent possible.

1. Ease exposed edges to a radius of approximately 1/32 inch, unless otherwise indicated. Form bent-metal corners to smallest radius possible without causing grain separation or otherwise impairing work.
 2. Remove sharp or rough areas on exposed traffic surfaces.
- B. Pipe Bollards:
1. Fabricate pipe bollards from Schedule 40 steel pipe unless otherwise indicated.
 2. Fabricate sleeves for bollard anchorage from steel pipe with 1/4-inch thick steel plate welded to bottom of sleeve.

2.05 FINISHES

- A. Comply with NAAMM's "Metal Finishes Manual for Architectural and Metal Products" for recommendations for applying and designating finishes.
1. Finish metal fabrications after assembly.
- B. Steel And Iron Finishes:
1. Hot-dip galvanize items as indicated to comply with applicable standard listed below:
 - a. ASTM A 123, for galvanizing steel and iron products.
 - b. ASTM A 153/A 153M, for galvanizing steel and iron hardware.
 2. Prepare uncoated ferrous-metal surfaces to comply with minimum requirements indicated below for SSPC surface-preparation specifications and environmental exposure conditions of installed metal fabrications:
 - a. Exteriors (SSPC Zone 1B): SSPC-SP 6/NACE No. 3, "Commercial Blast Cleaning."
 3. Apply shop primer to uncoated surfaces of metal fabrications, except those with galvanized finishes and those to be embedded in concrete, sprayed-on fireproofing, or masonry, unless otherwise indicated. Comply with SSPC-PA 1, "Paint Application Specification No. 1," for shop painting.

PART 3 - EXECUTION

3.01 INSTALLATION

- A. Provide temporary bracing or anchors in formwork for items that are to be built into concrete, masonry, or similar construction.
1. Field Welding: Comply with the following requirements:
 - a. Use materials and methods that minimize distortion and develop strength and corrosion resistance of base metals.
 - b. Obtain fusion without undercut or overlap.
 - c. Remove welding flux immediately.
 - d. At exposed connections, finish exposed welds and surfaces smooth and blended so no roughness shows after finishing and contour of welded surface matches that of adjacent surface.
- B. Installing Pipe Bollards:
1. Anchor bollards in concrete in formed or core-drilled holes not less than 8 inches deep and 3/4 inch greater than OD of bollard. After bollards have been inserted into holes, fill annular space surrounding bollard solidly with nonshrink,

nonmetallic grout, mixed and placed to comply with grout manufacturer's written instructions. Slope grout up approximately 1/8 inch toward bollard.

2. Fill bollards solidly with concrete, mounding top surface.

3.02 ADJUSTING AND CLEANING

- A. Galvanized Surfaces: Clean field welds, bolted connections, and abraded areas and repair galvanizing to comply with ASTM A 780.

END OF SECTION

SECTION 05910 - GALVANIZING

PART 1 - GENERAL

1.01 RELATED DOCUMENTS

- A. Drawings and general provisions of the Contract, including General and Supplementary Conditions and Division 1 Specification Sections, apply to this Section.

1.02 RELATED DOCUMENTS

- A. Drawings and general provisions of the Contract, including General and Supplementary Conditions and other Division 1 Specification Sections, apply to this Section.

1.03 DESCRIPTION

- A. Work of this Section includes hot dip galvanizing of structural steel members, assemblies and metal fabrications.

1.04 RELATED WORK

- A. Electrodeposited zinc coatings (electrogalvanized) on steel materials is specified in other specification Sections.

1.05 DEFINITIONS

- A. Hot dip galvanizing is the dipping of steel members and assemblies into molten zinc for lasting or long term corrosion protection. The resultant zinc coating fuses permanently with the base steel material.
- B. Electrogalvanizing is the electrodepositing or electroplating with zinc by electrolysis for limited corrosion protection. Electrogalvanized materials are suitable primarily for interior applications.
- C. Passivating is the chemical treatment of freshly galvanized steel materials to prevent humid storage stain (white rust or white corrosion). This treatment consists of quenching freshly galvanized steel in water to which chromate or a chromic-acid solution or other proprietary solution, has been added.

1.06 APPLICABLE REFERENCE STANDARDS

- A. Requirements, abbreviations and acronyms for reference standards are defined in Section 01090.
- B. American Hot Dip Galvanizers Association Inc. (AHDGA):
 - 1. "Inspection Manual for Hot Dip Galvanized Products."
- C. "The Design and Fabrication of Galvanized Products."
- D. American Society of Testing and Materials (ASTM)
 - 1. A90 Weight of Coating on Zinc-Coated (Galvanized) Iron or Steel Articles
 - 2. A120 Pipe, Steel, Black and Hot Dipped Zinc Coated Galvanized Welded and Seamless for Ordinary Uses.
 - 3. A123 Zinc (Hot Galvanized) Coatings on Products Fabricated from Rolled, Pressed, and Forged Steel Shapes, Plates, Bars, and Strips.
 - 4. A143 Safeguarding against embrittlement of hot dip galvanized structural steel

products and procedure for detecting embrittlement.

5. A153 Zinc Coating Hot Dip on Iron and Steel Hardware.
 6. A239 Locating the Thinnest Spot in a Zinc Coating in Iron or Steel Articles by the Preece Test.
 7. A325 High-Strength Bolts for Structural Steel Joints. Including Suitable Nuts and Plain Hardened Washers.
 8. A361 Steel Sheet, Zinc Coated by the Hot Dip Process for Roofing and Siding.
 9. A384 Safeguarding Against Warpage and Distortion During Hot Dip Galvanizing of Steel Assemblies
 10. A384 Safeguarding Against Warpage and Distortion During Hot Dip Galvanizing of Steel Assemblies
 11. A385 Providing High Quality Zinc Coatings
 12. A386 Zinc Coating on Assembled Steel Products.
 13. A444 Steel Sheet, Zinc-Coated by the Hot Dip Process, for Culverts and Undergrounds
 14. A446 Steel Sheet, Zinc-Coated by the Hot Dip Process, Structural Quality.
 15. A525 Steel Sheet, Zinc coated by the Hot Dip Process, General Requirements
 16. A526 Steel Sheet, Zinc-Coated Galvanized by the Hot Dip Process, Commercial Quality
 17. A527 Steel Sheet, Zinc-Coated by the Hot Dip Process, Lock Forming Quality.
 18. A528 Steel Sheet, Zinc-Coated by the Hot Dip Process Drawing Quality.
 19. A563 Carbon Steel Nuts
 20. A642 Steel Sheet, Zinc Coated Galvanized by the Hot Dip Process, Drawing Quality, Special Killed
 21. B6 Zinc (Slab Zinc)
 22. D2092 Preparation of Zinc-Coated Steel Surfaces for Painting
 23. E376 Measuring Coating Thickness by Magnetic Field or Eddy Current Test Methods
- E. American Association of State Highway and Transportation Officials (AASHTO):
1. M36 Zinc Coated Galvanized Corrugated Iron or Steel Culverts and Underdrains
 2. M111 Zinc hot galvanized coatings on products fabricated from rolled, pressed, and forged steel shapes, plates, bars, and strips.
 3. M120 Zinc Metal Slab Zinc
 4. M218 Zinc Coated galvanized iron or steel sheets for culverts and underdrains.
 5. M232 Zinc coating hot dip on iron and steel hardware
- F. American Welding Society (AWS):
1. D19.0 Welding Zinc-Coated Steel
- G. Canadian Standards Association CSA:
1. G164 Hot Dip Galvanizing of Irregularly Shaped Articles

1.07 QUALITY ASSURANCE

- A. Furnish Certificates of Compliance with ASTM Specifications and Standards specified herein. Each certificate shall be signed by Contractor and Galvanizer certifying that steel materials, bolts, nuts, washers, and items of iron and steel hardware conform to

specified requirements.

- B. Inspections, test and samples shall conform to ASTM Specifications and Standards. Inspection rights and privileges, procedures, and acceptance or rejection of galvanized steel materials shall conform to ASTM A123. Inspections and tests may include the following:
 - 1. Visual examination of samples and finished products
 - 2. Tests to determine weight or mass of zinc coating per square foot of steel surface.
 - 3. Tests to determine distribution and uniformity of zinc coating.

1.08 SUBMITTALS

- A. Furnish Certificates of Compliance, with certified original and two copies forwarded to Architect.

1.09 PRODUCT DELIVERY, STORAGE AND HANDLING

- A. Packaging shall be of type to prevent damage to galvanized surfaces and distortion of steel materials and components.
- B. Handling and storage shall conform to ASTM A123. Handle and protect galvanized materials from damage to zinc coating. To avoid humid storage stain, space surfaces of galvanized materials to permit free circulation of air.
- C. Repair material showing evidence of damage to zinc coating. If not repairable, material with damaged coating will be subject to rejection.

PART 2 - PRODUCTS

2.01 STEEL MATERIALS

- A. Materials shall be chemically suitable for galvanizing: Notify galvanizer of need for special processing techniques for steel items containing carbon above 0.25 percent, phosphorous above 0.05 percent, and manganese above 1.35 percent, either individually or in combination, and providing silicon content is 0.05 or more.

2.02 IRON AND STEEL HARDWARE

- A. Bolts, nuts, washers, and items of iron and steel hardware furnished for galvanizing shall be suitable for hot dip galvanizing.
- B. Inspect iron and steel hardware before galvanizing and ascertain whether suitable for galvanizing. Replace items which are not suitable for galvanizing.

2.03 ZINC

- A. Zinc for galvanizing shall conform to ASTM B6 as specified in ASTM A123.

2.04 GALVANIZING

- A. Steel members, fabrications, and assemblies shall be galvanized after fabrication by hot dip process in accordance with ASTM A123. Weight of zinc coating shall conform to requirements specified under Weight of Coating in ASTM A123 or ASTM A386, as applicable.
- B. Safeguard against steel embrittlement in conformance with ASTM A143.

- C. Safeguard against warpage or distortion of steel members in accordance with ASTM A384. Notify Architect of potential warpage problems which may require modification in design, before proceeding with steel fabrications.
- D. Finish and uniformity of zinc coating and adherence of coating shall conform to ASTM A123.
- E. Bolts, nuts, and washers, and iron and steel hardware components shall be galvanized in accordance with ASTM A153. Weight of zinc coating shall conform to requirements specified under Weight of Coating in ASTM A153. Nuts shall be tapped after galvanized to minimum diametral amounts specified in ASTM A563. Coat nuts with waterproof lubricant, clean and dry to touch. High strength bolts for structural steel joints shall be galvanized in accordance with ASTM A325.

2.05 PASSIVATING

- A. Galvanizing materials subject to extended periods of storage in open, exterior locations shall be given passivating treatment or light oiling to prevent humid storage stain. Treatment, solution and process shall be subject to review and acceptance by Architect.

2.06 PRESERVATIVE OILS

- A. Do not treat freshly galvanized or passivated surfaces with oils, grease, or chemicals which might interfere with adhesion of subsequent paint primers and coatings.

2.07 PAINTING

- A. Prepare galvanized metal surfaces to be field painted in accordance with ASTM D2092.
- B. Shop coat galvanized metal surfaces with approved galvanized primer.

PART 3 - EXECUTION

3.01 INSTALLATION OF STEEL MATERIALS

- A. Installation of steel materials, fabrications, and assemblies is specified in various other specification Sections.

3.02 FIELD INSPECTION

- A. Inspect the installed galvanized materials, fabrications, and assemblies to conform to applicable requirements of ADHGA Inspection Manual for Hot Dip Galvanized Products.

3.03 TOUCHUP AND REPAIR

- A. Repair damaged galvanized surfaces by one of the following methods.
 1. For sprayed zinc surfaces, clean and preheat to assure freedom from loose material, moisture, oil, grease, or other foreign matter before applying zinc. Apply zinc coating by metallizing spray to clean and dry surfaces.
 2. Clean zinc-based solders and wire to remove loose material and contaminants, and heat to approximately 572 degrees F (300 degrees C). Apply zinc-alloy repair compound by spreading material over heated surface in accordance with compound manufacturer's instructions. Remove the repair compound residues with damp cloth or by rising with water.
- B. Dry film thickness of applied repair materials shall be not less than galvanized coating thickness required by ASTM A120, A123, or A153, as applicable.

- C. Touch up prime-painted surfaces with the same galvanized primer applied in shop. Clean the damaged surfaces first to assure proper paint adhesion.

END OF SECTION

SECTION 06100 - ROUGH CARPENTRY

PART 1 - GENERAL

1.01 RELATED DOCUMENTS

- A. Drawings and general provisions of the Contract, including General and Supplementary Conditions and Division 1 Specification Sections, apply to this Section.

1.02 SUMMARY

- A. Section includes:
 - 1. Wood blocking and nailers.
 - 2. Plywood backing panels for telephone and electrical panel backboards.
- B. Related Section includes Division 9 Section "Sheathing" for gypsum sheathing.

1.03 DEFINITIONS

- A. Rough Carpentry: Carpentry work not specified in other Sections and not exposed, unless otherwise indicated.
- B. Lumber grading agencies, and the abbreviations used to reference them, include the following:
 - 1. SPIB - Southern Pine Inspection Bureau.
 - 2. WCLIB - West Coast Lumber Inspection Bureau.
 - 3. WWPA - Western Wood Products Association.

1.04 SUBMITTALS

- A. Submit Manufacturer's Acknowledgement Letter. Follow Division 1 Section "Submittal Procedures."
- B. Submit product data for each type of process and factory-fabricated product. Indicate component materials and dimensions and include construction and application details.
 - 1. Include data for wood-preservative treatment from chemical treatment manufacturer and certification by treating plant that treated materials comply with requirements. Indicate type of preservative used, net amount of preservative retained, and chemical treatment manufacturer's written instructions for handling, storing, installing, and finishing treated material.
 - 2. For products receiving a waterborne treatment, include statement that moisture content of treated materials was reduced to levels specified before shipment to Project site.
 - 3. Include copies of warranties from chemical treatment manufacturers for each type of treatment.
- C. Submit Research/Evaluation Reports for the following, showing compliance with building code in effect for Project:
 - 1. Preservative-treated wood.
 - 2. Power-driven fasteners.
 - 3. Powder-actuated fasteners.
 - 4. Expansion anchors.

5. Metal framing anchors.

1.05 DELIVERY, STORAGE, AND HANDLING

- A. Stack lumber, plywood, and other panels; place spacers between each bundle to provide air circulation. Provide for air circulation around stacks and under coverings.

PART 2 - PRODUCTS

2.01 WOOD PRODUCTS, GENERAL

- A. Lumber shall comply with DOC PS 20 and applicable rules of lumber grading agencies certified by the American Lumber Standards Committee Board of Review.
 1. Factory mark each piece of lumber with grade stamp of grading agency.
 2. Where nominal sizes are indicated, provide actual sizes required by DOC PS 20 for moisture content specified. Where actual sizes are indicated, they are minimum dressed sizes for dry lumber.
 3. Provide dressed lumber, S4S, unless otherwise indicated.
 4. Provide dry lumber with 19 percent maximum moisture content at time of dressing for 2-inch nominal thickness or less, unless otherwise indicated.
- B. Wood Structural Panels:
 1. Plywood shall be either DOC PS 1 or DOC PS 2, unless otherwise indicated.
 2. Thickness shall be as needed to comply with requirements specified but not less than thickness indicated.
 3. Factory mark panels according to indicated standard.

2.02 WOOD-PRESERVATIVE-TREATED MATERIALS

- A. Preservative Treatment by Pressure Process: AWPAC2 (lumber) and AWPAC9 (plywood), except that lumber that is not in contact with the ground and is continuously protected from liquid water may be treated according to AWPAC31 with inorganic boron (SBX).
 1. Preservative Chemicals: Acceptable to authorities having jurisdiction and one of the following:
 - a. Chromated copper arsenate (CCA).
 - b. Ammoniacal copper citrate (CC).
 - c. Copper azole, Type A (CBA-A).
- B. Kiln-dry material after treatment to a maximum moisture content indicated. Do not use material that is warped or does not comply with requirements for untreated material.
 1. Lumber: 19 percent for lumber.
 2. Plywood: 15 percent.
- C. Mark each treated item with the treatment quality mark of an inspection agency approved by the American Lumber Standards Committee Board of Review.
- D. Treat all rough carpentry, unless otherwise indicated.
- E. Treat items indicated on Drawings, and the following:
 1. Wood cants, nailers, curbs, equipment support bases, blocking, stripping, and similar members in connection with roofing, flashing, vapor barriers, and waterproofing.
 2. Wood sleepers, blocking, furring, stripping, and similar concealed members in contact with masonry or concrete.

2.03 DIMENSION LUMBER

- A. Provide dimension lumber of grades indicated according to the American Lumber Standards Committee National Grading Rule provisions of the grading agency indicated.
- B. Walkboards for Attic Access: Construction or No. 2 grade and any of the following species:
 - 1. Hem-fir; WCLIB or WWPA.
 - 2. Mixed southern pine; SPIB.

2.04 MISCELLANEOUS LUMBER

- A. Provide lumber for support or attachment of other construction, including the following:
 - 1. Blocking.
 - 2. Nailers.
 - 3. Furring.
 - 4. Grounds.
- B. For items of dimension lumber size, provide Construction, Stud, or No. 2 grade lumber with 19 percent maximum moisture content and the following species:
 - 1. Mixed southern pine; SPIB.
 - 2. Western woods; WCLIB or WWPA.
- C. For concealed boards, provide lumber with 19 percent maximum moisture content and any of the following species and grades:
 - 1. Mixed southern pine, No. 2 grade; SPIB.
- D. For furring strips for installing plywood or hardboard paneling, select boards with no knots capable of producing bent-over nails and damage to paneling.

2.05 PLYWOOD BACKING PANELS

- A. Telephone and electrical equipment backing panels shall be DOC PS 1, Exposure 1, C-D Plugged, fire-retardant treated, in thickness indicated or, if not indicated, not less than 1/2 inch thick.

2.06 FASTENERS

- A. Provide fasteners of size and type indicated that comply with requirements specified in this Article for material and manufacture.
 - 1. Where rough carpentry is exposed to weather, in ground contact, or in area of high relative humidity, provide fasteners of Type 304 stainless steel complying with ASTM A 153M.
- B. Nails, Brads, and Staples: ASTM F 1667.
- C. Power-Driven Fasteners: CABO NER-272.
- D. Wood Screws: ASME B18.6.1.
- E. Screws for Fastening to Cold-Formed Metal Framing: ASTM C 954, except with wafer heads and reamer wings, length as recommended by screw manufacturer for material being fastened.
- F. Lag Bolts: ASME B18.2.1.
- G. Bolts: Steel bolts complying with ASTM A 307, Grade A; with ASTM A 563 hex nuts and, where indicated, flat washers.

- H. Expansion Anchors: Anchor bolt and sleeve assembly of material indicated below with capability to sustain, without failure, a load equal to 6 times the load imposed when installed in unit masonry assemblies and equal to 4 times the load imposed when installed in concrete as determined by testing per ASTM E 488 conducted by a qualified independent testing and inspecting agency.
1. Material: Stainless steel with bolts and nuts complying with ASTM F 593 and ASTM F 594, Alloy Group 1 or 2.

2.07 MISCELLANEOUS MATERIALS

- A. Sill-Sealer Gaskets: Closed-cell neoprene foam, 1/4 inch thick, selected from manufacturer's standard widths to suit width of sill members indicated.
- B. Adhesives for Field Gluing Panels to Framing: Formulation complying with APA AFG-01 that is approved for use with type of construction panel indicated by both adhesive and panel manufacturers.
- C. Water-Repellent Preservative: NWWDA-tested and -accepted formulation containing 3-iodo-2-propynyl butyl carbamate, combined with an insecticide containing chloropyrifos as its active ingredient.

PART 3 - EXECUTION

3.01 INSTALLATION, GENERAL

- A. Set rough carpentry to required levels and lines, with members plumb, true to line, cut, and fitted. Fit rough carpentry to other construction; scribe and cope as needed for accurate fit. Locate furring, nailers, blocking, grounds and similar supports to comply with requirements for attaching other construction.
- B. Do not use materials with defects that impair quality of rough carpentry or pieces that are too small to use with minimum number of joints or optimum joint arrangement.
- C. Apply field treatment complying with AWWPA M4 to cut surfaces of preservative-treated lumber and plywood.
- D. Securely attach rough carpentry work to substrate by anchoring and fastening as indicated, complying with the following:
1. CABO NER-272 for power-driven fasteners.
 2. Published requirements of metal framing anchor manufacturer.
 3. Table 23-II-B-1, "Nailing Schedule," and Table 23-II-B-2, "Wood Structural Panel Roof Sheathing Nailing Schedule," in the Uniform Building Code.
 4. Table 2304.9.1, "Fastening Schedule," International Building Code.
- E. Use common wire nails, unless otherwise indicated. Select fasteners of size that will not fully penetrate members where opposite side will be exposed to view or will receive finish materials. Make tight connections between members. Install fasteners without splitting wood; predrill as required.
- F. Use finishing nails for exposed work, unless otherwise indicated. Countersink nail heads and fill holes with wood filler.

3.02 WOOD SLEEPER, BLOCKING, AND NAILER INSTALLATION

- A. Install where indicated and where required for attaching other work. Form to shapes indicated and cut as required for true line and level of attached work. Coordinate locations with other work involved.

- B. Attach items to substrates to support applied loading. Recess bolts and nuts flush with surfaces, unless otherwise indicated. Build anchor bolts into masonry during installation of masonry work. Where possible, secure anchor bolts to formwork before concrete placement.

END OF SECTION

SECTION 06660 - SOLID POLYMER FABRICATIONS

PART 1 - GENERAL

1.01 RELATED DOCUMENTS

- A. Drawings and general provisions of the Contract, including General and Supplementary Conditions and Division 1 Specification Sections, apply to this Section.

1.02 WORK INCLUDED

- A. Window sills.

1.03 SUBMITTALS

- A. Submit shop drawings indicating dimensions, component sizes, fabrication details, attachment provisions and coordination requirements with adjacent work.
- B. Submit minimum 6" X 6" samples. Indicate full range of color and pattern variation. Approved samples will be retained as a standard for work.
- C. Submit product data. Indicate product description, fabrication information and compliance with specified performance requirements.
- D. Submit manufacturer's care and maintenance data, including repair and cleaning instructions. Include in project closeout documents.

1.04 DELIVERY, STORAGE AND HANDLING

- A. Deliver no components to project site until areas are ready for installation. Store indoors.
- B. Handle materials to prevent damage to finished surfaces. Provide protective coverings to prevent physical damage or staining following installation for duration of project.

1.05 QUALITY CONTROL

- A. Allowable tolerances:
 - 1. Variation in component size: plus or minus 1/8".
 - 2. Location of openings: plus or minus 1/8" from indicated location.

1.06 WARRANTY

- A. Provide transferable manufacturer's warranty that manufacturer will repair or replace, without charge, their product if it fails due to a manufacturing defect during the first 10 years after initial installation. This includes reasonable labor charges needed to repair or replace the product covered hereunder.

PART 2 - PRODUCTS

2.01 SOLID POLYMER FABRICATIONS

- A. Material: Cast homogenous polymer alloy, filled, acrylic; not coated, laminated or of composite construction, meeting ANSI Z124-1980, Type Six, and Fed. Spec. WW-P-541E/GEN dated August 1, 1980
 - 1. Material shall have minimum physical and performance properties specified.

2. Superficial damage to a depth of 0.10" shall be repairable by sanding or polishing.
- B. Manufacturer/products
 1. E.I. du Pont de Nemours & Co., Inc., Wilmington, DE, "Corian"
 2. Nevamar Corporation, Odenton, MD, "Fountainhead"
 - C. Window sills: 3/4" thick solid polymer, adhesively joined with no exposed seams, having edge details as indicated on Drawings.

2.02 ACCESSORY PRODUCTS

- A. Joint Adhesive: Manufacturer's standard two-part adhesive kit to create inconspicuous, non-porous joints.
- B. Sealant: Manufacturer's standard mildew-resistant, FDA/UL recognized silicone sealant in colors matching components.

2.03 FABRICATION

- A. Factory fabricate components to greatest extent practicable to sizes and shapes indicated, in accordance with approved shop drawings.
- B. Form joints between component using manufacturer's standard joint adhesive; without conspicuous joints.
- C. Provide factory cutouts for plumbing fittings and bath accessories as indicated on the drawings
- D. Cut and finish component edges with clean, sharp returns. Route radii and contours to template. Repair or reject defective and inaccurate work.

PART 3 - EXECUTION

3.01 INSTALLATION

- A. Install components plumb and level, scribed to adjacent finishes, in accordance with shop drawings and product installation data.
- B. Form field joints using manufacturer's recommended adhesive, with joints inconspicuous in finished work. Keep components and hands clean when making joints.
- C. Provide backsplashes and sidesplashes as indicated on the drawings. Adhere to countertops using manufacturer's standard color-matched silicone sealant.
- D. Keep component and hands clean during installation. Remove adhesives, sealants and other stains. Replace stained components.
- E. Protect surfaces from damage and keep clean until Date of Substantial Completion. Repair work or replace damaged work that cannot be repaired to architect's satisfaction.

END OF SECTION

SECTION 07210 – THERMAL INSULATION

PART 1 - GENERAL

1.01 RELATED DOCUMENTS

- A. Drawings and general provisions of the Contract, including General and Supplementary Conditions and Division 1 Specification Sections, apply to this Section.

1.02 SUMMARY

- A. Section includes concealed building insulation.

1.03 SUBMITTALS

- A. Submit manufacturer's acknowledgment letter. Comply with Division 1 Section "Submittal Procedures".
- B. Submit product data for each type of product indicated.

1.04 QUALITY ASSURANCE

- A. Obtain each type of building insulation through one source.
- B. Provide insulation and related materials with the fire-test-response characteristics indicated, as determined by testing identical products per test method indicated below by UL or another testing and inspecting agency acceptable to authorities having jurisdiction. Identify materials with appropriate markings of applicable testing and inspecting agency.
 - 1. Surface-Burning Characteristics: ASTM E 84.
 - 2. Fire-Resistance Ratings: ASTM E 119.
 - 3. Combustion Characteristics: ASTM E 136.

1.05 DELIVERY, STORAGE, AND HANDLING

- A. Protect insulation materials from physical damage and from deterioration by moisture, soiling, and other sources. Store inside and in a dry location. Comply with manufacturer's written instructions for handling, storing, and protecting during installation.
 - 1. Complete installation and concealment of plastic materials as rapidly as possible in each area of construction.

PART 2 - PRODUCTS

2.01 MANUFACTURERS

- A. Subject to compliance with requirements, manufacturers offering products that may be incorporated into the Work include, but are not limited to, the following:
 - 1. Glass-Fiber Insulation:
 - a. CertainTeed Corporation.
 - b. Johns Manville Corporation.
 - c. Owens Corning.

2.02 INSULATING MATERIALS

- A. Provide insulating materials that comply with requirements and with referenced standards.

1. Provide preformed units in sizes to fit applications indicated; selected from manufacturer's standard thicknesses, widths, and lengths.
- B. Unfaced Mineral-Fiber Blanket Insulation: ASTM C 665, Type I (blankets without membrane facing); consisting of fibers manufactured from glass; with maximum flame-spread and smoke-developed indices of 25 and 50, respectively; passing ASTM E 136 for combustion characteristics.

2.03 AUXILIARY INSULATING MATERIALS

- A. Adhesive for bonding insulation shall be product with demonstrated capability to bond insulation securely to substrates indicated without damaging insulation and substrates.
- B. Eave ventilation troughs shall be preformed, rigid fiberboard or plastic sheets designed and sized to fit between roof framing members and to provide cross ventilation between insulated attic spaces and vented eaves.

PART 3 - EXECUTION

3.01 EXAMINATION

- A. Examine substrates and conditions, with Installer present, for compliance with requirements for Sections in which substrates and related work are specified and other conditions affecting performance.
- B. Proceed with installation only after unsatisfactory conditions have been corrected.

3.02 PREPARATION

- A. Clean substrates of substances harmful to insulations or vapor retarders, including removing projections capable of puncturing vapor retarders or of interfering with insulation attachment.

3.03 GENERAL INSTALLATION

- A. Comply with insulation manufacturer's written instructions applicable to products and application indicated.
- B. Install insulation that is undamaged, dry, and unsoiled and that has not been left exposed at any time to ice and snow.
- C. Extend insulation in thickness indicated to envelop entire area to be insulated. Cut and fit tightly around obstructions and fill voids with insulation. Remove projections that interfere with placement.
- D. Water-Piping Coordination: If water piping is located on inside of insulated exterior walls, coordinate location of piping to ensure that it is placed on warm side of insulation and insulation encapsulates piping.
- E. Apply single layer of insulation to produce thickness indicated, unless multiple layers are otherwise shown or required to make up total thickness.

3.04 INSTALLATION OF GENERAL BUILDING INSULATION:

- A. Apply insulation units to substrates by method indicated, complying with manufacturer's written instructions. If no specific method is indicated, bond units to substrate with adhesive or use mechanical anchorage to provide permanent placement and support of units.
- B. Install mineral-fiber blankets in cavities formed by framing members according to the following requirements:
1. Use blanket widths and lengths that fill the cavities formed by framing members. If more than one length is required to fill cavity, provide lengths that will produce a snug fit between ends.

2. Place blankets in cavities formed by framing members to produce a friction fit between edges of insulation and adjoining framing members.
- C. Stuff glass-fiber, loose-fill insulation into miscellaneous voids and cavity spaces where shown. Compact to approximately 40 percent of normal maximum volume equaling a density of approximately 2.5 lb/cu. ft..

3.05 PROTECTION

- A. Protect installed insulation from damage due to harmful weather exposures, physical abuse, and other causes. Provide temporary coverings or enclosures where insulation is subject to abuse and cannot be concealed and protected by permanent construction immediately after installation.

END OF SECTION

SECTION 07260 - UNDER-SLAB VAPOR BARRIER

PART 1 - GENERAL

1.01 RELATED DOCUMENTS

- A. Drawings and general provisions of the Contract, including General and Supplementary Conditions and Division 1 Specification Sections, apply to this Section.

1.02 SUMMARY

- A. Products supplied under this section include vapor barrier and installation accessories for installation under concrete slabs.
- B. Related sections:
 - 1. Division 3 Section "Cast-in-Place Concrete".

1.03 REFERENCES

- A. American Society for Testing and Materials (ASTM):
 - 1. ASTM E1745- Standard Specification for Plastic Water Vapor Retarders Used in Contact with Soil or Granular Fill Under Concrete Slabs.
 - 2. ASTM E1643- 11 Selection, Design, Installation, and Inspection of Water Vapor Retarders Used in Contact with Earth or Granular Fill Under Concrete Slabs.
- B. Technical Reference - American Concrete Institute (ACI):
 - 1. ACI 302.2R-06 Guide for Concrete Slabs that Receive Moisture-Sensitive Flooring Materials.

1.04 SUBMITTALS

- A. For quality control and assurance, submit the following:
 - 1. Summary of test results per paragraph 9.3 of ASTM E 1745.
 - 2. Manufacturer's samples and literature.
 - 3. Manufacturer's installation instructions for placement, seaming and penetration repair instructions.
 - 4. All mandatory ASTM E1745 testing must be performed on a single production roll per ASTM E1745 Section 8.1.

PART 2 - PRODUCTS

2.01 MATERIALS

- A. Vapor barrier shall have all of the following qualities:
 - 1. Maintain permeance of less than 0.01 Perms [grains/(ft² hr inHg)] as tested in accordance with mandatory conditioning tests per ASTM E1745 Section 7.1 (7.1.1-7.1.5).
 - 2. Other performance criteria:
 - a. Strength: ASTM E1745 Class A.
 - b. Thickness: 15 mils minimum
- B. Vapor barrier products:
 - 1. Basis of Design: Stego Wrap Vapor Barrier (15-mil) and accessories by Stego Industries LLC., (877) 464-7834 www.stegoindustries.com.

2. Approved Alternates:
 - a. Vaporguard by Reef Industries, 713-507-4250. www.reefindustries.com.
 - b. Sundance 15 mil Vapor Barrier by Sundance Inc., (855) 300-7156
www.sundancepolymertech.com.

2.02 ACCESSORIES

- A. For seams:
 1. Stego Tape by Stego Industries LLC, (877) 464-7834 www.stegoindustries.com.
- B. For penetrations of Vapor barrier:
 1. Stego Mastic by Stego Industries LLC, (877) 464-7834
www.stegoindustries.com.
 2. Stego Tape by Stego Industries LLC, (877) 464-7834 www.stegoindustries.com.
- C. For perimeter/edge seal:
 1. Stego Crete Claw by Stego Industries LLC, (887)464-7834
www.stegoindustries.com.
 2. Stego Term Barby Stego Industries LLC, (877) 464-7834
www.stegoindustries.com.
 3. StegoTack Tape (double sided) by Stego Industries LLC, (877) 464-7834
www.stegoindustries.com.

PART 3 - EXECUTION

3.01 PREPARATION

- A. Ensure that subsoil is approved by Architect or Geotechnical Engineer.
 1. Level and compact base material.

3.02 INSTALLATION

- A. Install vapor barrier in accordance ASTM E1643.
 1. Unroll vapor barrier with the longest dimension parallel with the direction of the concrete placement and face laps away from the expected direction of the placement whenever possible.
 2. Extend vapor barrier over footings and grade beams to a distance acceptable to the structural engineer or stop at impediments such as dowels and waterstops.
 3. Seal vapor barrier to slab perimeter/edge using Stego Crete Claw and remove dirt, debris, and mud from Crete Claw prior to concrete placement.
 4. Overlap joints 6 inches and seal with manufacturer's tape.
 5. Apply tape/Crete Claw to a clean and dry vapor barrier.
 6. Seal all penetrations (including pipes) per manufacturer's instructions.
 7. No penetration of the vapor barrier is allowed except for reinforcing steel and permanent utilities.
 8. Repair damaged areas by cutting patches of vapor barrier, overlapping damaged area 6 inches and taping all sides with tape.

END OF SECTION

SECTION 07270 - AIR BARRIERS

PART 1 - GENERAL

1.01 RELATED DOCUMENTS

- A. Drawings and general provisions of the Contract, including General and Supplementary Conditions and Division 1 Specification Sections, apply to this Section.

1.02 SUMMARY

- A. Section includes air/vapor barrier membrane system.
- B. Related Sections:
 - 1. Division 4 section "Unit Masonry"
 - 2. Division 7 section "Thermal Insulation"
 - 3. Division 7 section "Joint Sealants"
 - 4. Division 8 section "Steel Door and Frames"
 - 5. Division 9 section "Gypsum Sheathing"

1.03 SUBMITTALS

- A. Submit a complete set of standard details for the air/vapor barrier membrane systems showing a continuous plane of air tightness throughout the building envelope.
- B. Submit 8 inch square sample of air barrier sheet.
- C. Submit Installer Certificates signed by manufacturers certifying that installers comply with requirements.

1.04 QUALITY ASSURANCE

- A. Installer shall be a qualified installer who is acceptable to air barrier manufacturer to install manufacturer's products.
- B. At the beginning of the Work and at all times during the execution of the Work, allow access to Work site by the air barrier membrane manufacturers' representative.
- C. Obtain air barrier materials, primers, and accessories through one source from a single manufacturer.
- D. Conduct preinstallation conference at Project site to comply with requirements in Division 1 Section "Project Management and Coordination." Review requirements for installing air barriers, including surface preparation specified under other Sections, substrate condition and pretreatment, forecasted weather conditions, special details and sheet flashings, installation procedures, testing and inspection procedures, and protection and repairs.
- E. Mock-Up:
 - 1. Where directed, construct typical exterior wall panel incorporating substrate, window frame, attachment of insulation, and showing air barrier membrane application details.
 - 2. Allow 24 hours for inspection of mock-up before proceeding with air barrier Work. Mock-up may remain as part of the Work.

1.05 DELIVERY, STORAGE AND HANDLING

- A. Storage:
 - 1. Store rolls according to manufacturer's written instructions.
 - 2. Store air/vapor barrier membranes, adhesives and primers at temperatures of 40°F and above to facilitate handling.
- B. Protect rolls from direct sunlight until ready for use.

1.06 PROJECT CONDITIONS

- A. Apply air barrier within the range of ambient and substrate temperatures recommended by manufacturer. Do not apply air barrier to a damp or wet substrate.

PART 2 - PRODUCTS

2.01 MATERIALS

- A. Primary Membrane
 - 1. Air/Vapor Barrier: SBS modified bitumen, self-adhering type, integrally laminated to a cross laminated polyethylene film, and having the following physical properties:
 - a. Thickness: 0.0394 inch (40 mils)
 - b. Air leakage: 0.0001 CFM/sq. ft. at 1.6 lbs/sq. ft. to ASTM E283 and no change in air leakage when tested at 62.8 lbs/sq. ft.2 to ASTM E330-90
 - c. Vapor permeance: 0.05 perms to ASTM E96.
 - d. Low temperature flexibility: Pass at 22°deg F to CGSB 37-GP-56M;
 - e. Elongation: 200 percent min. to ASTM D412;
 - 2. Acceptable manufacturer/product (or approved alternate): Blueskin SA as manufactured by Henry Company, El Segundo, CA 90245, <http://us.henry.com/>.
- B. Primer
 - 1. Sheet Membrane Primer:
 - a. Synthetic rubber based adhesive type, quick setting, having the following physical properties:
 - (1) Color: Blue;
 - (2) Weight: 6.7 lbs./gal.
 - (3) Solids by weight: 35 percent;
 - (4) Drying time (initial set): 30 minutes.
 - b. Acceptable manufacturer/product (or approved alternate): Blueskin Primer as manufactured by Henry Company.
 - 2. Sheet Membrane Primer: polymer emulsion type, quick setting, non-flammable during application, low VOC, having the following physical properties:
 - a. Color: Aqua;
 - b. Weight: 1.0 kg/l;
 - c. Solids by weight: 53%;
 - d. Water based, no solvent odors
 - e. Drying time (initial set): 30 minutes at 50% RH and 70°F;
 - f. Acceptable manufacturer/product (or approved alternate): Aquatac Primer as manufactured by Henry Company

- C. Through-wall flashing membrane and dampproof course (Self-Adhering):
 - 1. SBS modified bitumen, self-adhering sheet membrane complete with a cross-laminated polyethylene film, having the following physical properties:
 - a. Thickness: 40 mils.
 - b. Film Thickness: 9.0 mils
 - c. Puncture Resistance: 40 lbf to ASTM E154;
 - d. Tensile Strength (film): 34500 kPa (5000 psi) ASTN D882
 - e. Tear Resistance: 13lbs. to ASTM D1004;
 - f. Low temperature flexibility: -22°F to CGSB 37-GP-56M;
 - 2. Acceptable manufacturer/product (or approved alternate): Blueskin TWF as manufactured by Henry Company.
- D. Liquid air seal mastic and insulation adhesive:
 - 1. Synthetic, trowel applied, rubber based adhesive type, having the following characteristics:
 - a. Compatibility: With air/vapor barrier membrane, substrate and insulation.
 - b. Air leakage: 0.0026 CFM/sq. ft. at 2.1 lbs/sq. ft. to ASTM E283;
 - c. Water vapor permeance: 0.03 perms to ASTM E96
 - d. Long term flexibility: CGSB 71-GP-24M;
 - e. Chemical resistance: Alkalis and salt.
 - 2. Acceptable manufacturer/product (or approved alternate): Air-Bloc 21 insulation adhesive as manufactured by Henry.

PART 3 - EXECUTION

3.01 EXAMINATION

- A. Verify that surfaces and conditions are ready to accept the Work of this section. Notify contractor in writing of any discrepancies. Commencement of the work or any parts thereof shall mean acceptance of the prepared substrate.

3.02 PREPARATION

- A. All surfaces must be sound, dry, clean and free of oil, grease, dirt, excess mortar or other contaminants. Fill spalled areas in substrate to provide an even plane.
- B. New concrete should be cured for a minimum of 14 days and must be dry before air/vapor barrier membranes are applied.

3.03 INSTALLATION

- A. Primer for Air/Vapor Barrier and Through-wall Flashing Membrane (Self-Adhering Type only)
 - 1. Apply primer for self-adhering membranes at rate recommended by manufacturer.
 - 2. Apply primer to all areas to receive air/vapor barrier sheet and/or through-wall flashing membrane, as indicated on drawings by roller or spray and allow minimum 30 minute open time. Primed surfaces not covered by Blueskin SA membrane or Blueskin TWF through-wall flashing membrane during the same working day must be re-primed.
- B. Air/Vapor Barrier membrane:

1. Position Blueskin SA for alignment and remove protective film. Press firmly into place.
 2. Ensure minimum 2 inches overlap at all end and side laps. Promptly roll all laps with a counter top roller to effect seal. When installed horizontally, do so in a shingle fashion.
 3. Tie-in to window frames, door frames, roofing system and at the interface of dissimilar materials as indicated in drawings. Refer to manufacturers standard details.
 4. Ensure all projections, including wall ties, are properly sealed with a trowel or caulk application of Air-Bloc 21.
 5. Inspection: Notify contractor when sections of work are complete so as to allow for review prior to installing insulation.
- C. Through-wall Flashing Membrane (Self-Adhering Type)
1. Align and position the leading edge of Blueskin TWF self-adhering through-wall flashing membrane with the front horizontal edge of the foundation walls or self angles, partially remove protective film and roll membrane over surface and up vertically.
 2. Press firmly into place. Ensure minimum 2-inch overlap at all end and side laps.
 3. Promptly roll all laps and membrane to effect the seal.
 4. Ensure through-wall flashing membrane extends fully to the exterior face of the exterior masonry veneer. Trim off excess as directed by the consultant.
 5. Apply through-wall flashing membrane along the base of masonry veneer walls, over windows, doors and all other wall openings. Membrane shall form continuous flashing and shall extend up a minimum of 8" up the back-up wall.

END OF SECTION

SECTION 07311 - ASPHALT SHINGLES

Issued as part of Plan Revision 1

PART 1 - GENERAL

1.01 RELATED DOCUMENTS

- A. Drawings and general provisions of the Contract, including General and Supplementary Conditions and Division 1 Specification Sections, apply to this Section.

1.02 WORK INCLUDED

- A. Asphalt roofing shingles.
- B. Leak barrier and roof deck protection.
- C. Metal flashing associated with shingle roofing.
- D. Attic ventilation.

1.03 RELATED WORK SPECIFIED ELSEWHERE

- A. Division 6 Section "Rough Carpentry" for wood sheathing and framing.
- B. Division 7 Section "Flashing and Sheet Metal" for step flashing, drip edges, and other sheet metal work.

1.04 SUBMITTALS

- A. Submit each item in this Article according to the Conditions of the Contract and Division 1 Specification Sections.
- B. Submit product data for each type of product specified, including details of construction relative to materials, dimensions of individual components, profiles, textures, and colors.
- C. Submit samples for initial selection in the form of manufacturer's sample finishes showing the full range of colors and profiles available for each type of asphalt shingle indicated.
- D. Submit samples for verification in the form of 2 full-size units of each type of asphalt shingle indicated showing the full range of variations expected in these characteristics.

1.05 QUALITY ASSURANCE

- A. Where products with a fire-test-response classification are specified, provide asphalt shingles identical to those tested according to ASTM E 108 or UL 790 and listed by UL or another testing and inspecting agency acceptable to authorities having jurisdiction. Identify each bundle of asphalt shingles with appropriate markings indicating fire-test-response classification of applicable testing and inspecting agency.
- B. Where wind-resistant asphalt shingles are indicated, provide products identical to those tested according to ASTM D 3161 or UL 997 and passed. Identify each bundle of asphalt shingles with appropriate markings of applicable testing and inspecting agency.

1.06 DELIVERY, STORAGE, AND HANDLING

- A. Deliver materials to Project site in manufacturer's unopened bundles or containers with labels intact.

- B. Handle and store materials at Project site to prevent water damage, staining, or other physical damage. Store roll goods on end. Comply with manufacturer's recommendations for job-site storage, handling, and protection.

1.07 PROJECT CONDITIONS

- A. Proceed with installing asphalt shingles only when existing and forecasted weather conditions will permit work to be performed according to manufacturers' recommendations and warranty requirements, and when substrate is completely dry.

1.08 WARRANTY

- A. The special warranty specified in this Article shall not deprive the Owner of other rights the Owner may have under other provisions of the Contract Documents and shall be in addition to, and run concurrent with, other warranties made by the Contractor under requirements of the Contract Documents.
- B. Submit a written warranty signed by manufacturer agreeing to repair or replace asphalt shingles that fail in materials or workmanship within the specified warranty period. Failures include, but are not limited to, deformation or deterioration of asphalt shingles beyond normal weathering.
 - 1. Warranty Period: Manufacturer's standard but not less than 40 years after date of Substantial Completion.

1.09 EXTRA MATERIALS

- A. Furnish extra materials described below that match products installed, are packaged with protective covering for storage, and are identified with labels clearly describing contents.
 - 1. Furnish 1 square (100 s.f.) coverage of asphalt shingles, identical to those to be installed, in unbroken bundles.

PART 2 - PRODUCTS

2.01 MANUFACTURERS/PRODUCTS

- A. Provide GAF "Timberline American Harvest" fiberglass asphalt shingles
 - 1. Fire rating: Class A.
 - 2. With GAF "StainGuard" protection.
 - 3. ASTM D7158, Class H
 - 4. ASTM D3161 Type 1, Class F
 - 5. ASTM D3018 Type 1
 - 6. ASTM D3462
 - 7. Texas Department of Insurance approved
- B. Hip and Ridge Shingles: Manufacturer's standard, factory-precut units to match asphalt shingles.
- C. Subject to compliance with requirements, products that may be incorporated in the Work include, but are not limited to, the following:
 - 1. Ridge Vents: Air Vent, Inc. "Shinglevent II Class A"
 - 2. Waterproof Underlayment:
 - a. WinterGuard; CertainTeed Corporation.
 - b. Bituthene Ice and Water Shield; Grace: W.R. Grace & Co.

- c. Nordshield Ice and WaterGard; Nord Bitumi US, Inc.
- d. F210; Northern Elastomeric, Inc.
- e. Polyguard Deck Guard; Polyguard Products, Inc.
- f. Polyken 640 Underlayment Membrane; Polyken Technologies; Kendall Co. Division.
- g. QSC-707, Quaker Construction Products, Inc.
- h. Moisture Guard, Tamko Asphalt Products, Inc.
- i. Weather Watch, GAF Building Materials Corporation.
- j. Jiffy Seal Ice and Water Guard, Protecto Wrap Co.
- k. Ice Guard Membrane No. 108-AG, Royston Laboratories, Inc.

2.02 METAL TRIM AND FLASHING

- A. Galvanized-Steel Sheets: ASTM A 526, G 90 (ASTM A 526M, Z 275) hot-dip galvanized steel with coating designation according to ASTM A 525 (ASTM A 525M), mill phosphatized where indicated for painting; 0.0217 inch (0.55 mm) thick, unless otherwise indicated.
- B. Metal Drip Edge: Brake-formed sheet metal with at least a 2-inch (50-mm) roof deck flange and a 1-1/2-inch (38-mm) fascia flange with a 3/8-inch (9.6-mm) drip at lower edge. Furnish the following material in lengths of 8 or 10 feet (2.5 to 3 m).
 - 1. Material: Galvanized-steel sheets.
- C. Metal Flashing: Job-cut to sizes and configurations required.
 - 1. Material: Galvanized-steel sheets.
- D. Vent Pipe Flashing: Lead conforming to ASTM B 749, Type L51121, at least 1/16 inch (1.6 mm) thick, unless otherwise indicated. Provide lead sleeve sized to slip over and turn down into pipe, soldered to skirt at slope of roof extending at least 4 inches (100 mm) from pipe onto roof.

2.03 ACCESSORIES

- A. Ridge Vent: High-density polypropylene, nonwoven modified polyester, or other UV-stabilized plastic designed to be installed under asphalt shingles at ridge.
- B. Asphalt Plastic Cement: Nonasbestos fibrated asphalt cement, complying with ASTM D 4586.
- C. Nails: Aluminum or hot-dip galvanized steel, 0.120-inch-diameter barbed shank, sharp-pointed, conventional roofing nails with a minimum 3/8-inch-diameter head and of sufficient length to penetrate 3/4 inch into solid decking or at least 1/8 inch through plywood sheathing.
 - 1. Where nails are in contact with flashing, prevent galvanic action by providing nails made from the same metal as that of the flashing.

PART 3 - EXECUTION

3.01 EXAMINATION

- A. Examine substrate for compliance with requirements for substrates, installation tolerances, and other conditions affecting performance of asphalt shingles. Do not proceed with installation until unsatisfactory conditions have been corrected.

3.02 PREPARATION

- A. Clean substrates of projections and substances detrimental to application. Cover knotholes or other minor voids in substrate with sheet metal flashing secured with noncorrosive roofing nails.
- B. Coordinate installation with flashings and other adjoining work to ensure proper sequencing. Do not install roofing materials until all vent stacks and other penetrations through roof sheathing have been installed and are securely fastened against movement.

3.03 INSTALLATION

- A. Comply with manufacturer's instructions and recommendations but not less than those recommended by ARMA's "Residential Asphalt Roofing Manual" or "The NRCA Steep Roofing Manual."
 - 1. Fasten asphalt shingles to roof sheathing with nails.
- B. Apply 1 layer of underlayment horizontally over entire surface to receive asphalt shingles, lapping succeeding courses a minimum of 2 inches (50 mm), end laps a minimum of 4 inches (100 mm), and hips and valleys a minimum of 6 inches (150 mm). Fasten underlayment with sufficient number of roofing nails or noncorrosive staples to hold in place until asphalt shingle installation.
- C. Center a 36-inch-wide strip of underlayment in valley and secure with only enough nails to hold in place until asphalt shingles are installed. Lap roof underlayment over valley underlayment at least 6 inches.
- D. Woven and Closed-Cut Valleys: Comply with ARMA and NRCA recommendations.
- E. Install metal flashing and trim as indicated and according to details and recommendations of the "Asphalt Roofing" section of "The NRCA Steep Roofing Manual" and ARMA's "Residential Asphalt Roofing Manual."
- F. Install asphalt shingles, beginning at roof's lower edge, with a starter strip of roll roofing or inverted asphalt shingles with tabs removed. Fasten asphalt shingles in the desired weather exposure pattern; use number of fasteners per shingle as recommended by manufacturer. Use vertical and horizontal chalk lines to ensure straight coursing.
 - 1. Cut and fit asphalt shingles at valleys, ridges, and edges to provide maximum weather protection. Provide same weather exposure at ridges as specified for roof. Lap asphalt shingles at ridges to shed water away from direction of prevailing wind.
 - 2. Use fasteners at ridges of sufficient length to penetrate sheathing as specified.
 - 3. Pattern: 1/3 shingle spacing offset at succeeding courses.
- G. Ridge Vents: Install ridge vents according to manufacturer's instructions.

3.04 ADJUSTING

- A. Replace any damaged materials installed under this Section with new materials that meet specified requirements.

END OF SECTION

SECTION 07411 – MANUFACTURED ROOF PANELS

This section issued with Addendum 6

PART 1 - GENERAL

1.01 RELATED DOCUMENTS

- A. Drawings and general provisions of the Contract, including General and Supplementary Conditions and Division 1 Specifications Sections, apply to this Section.

1.02 DESCRIPTION OF WORK

- A. Extent of each type of prefinished roofing and siding is indicated on the drawings and by provisions of this section. Prefinished roofing/siding is hereby defined to include panels which are structurally capable of spanning between supports spaced as indicated.
- B. Types of panels required include the following:
 - 1. Prefinished prefinished "PBR" utility siding, 24 ga. intended for lapped-seam installation.

1.03 SUBMITTALS

- A. Submit manufacturer's acknowledgement letter. Follow Division 1 Section "Submittal Procedures."
- B. Submit product data. Include installation instructions, recommendations for each product, and data substantiating that materials comply with specified requirements.
 - 1. Certification by waterproofing contractor that products supplied comply with regulations control
- C. Submit large-scale detail of edge conditions, joints, corners, custom profiles, supports anchorages, trim, flashings, closures, and special details.

1.04 QUALITY ASSURANCE

- A. Prior to fabrication of prefabricated panels, take field measurements of structure or substrates to receive panel systems. Allow for trimming panel units where final dimensions cannot be established prior to fabrication.

PART 2 - PRODUCTS

2.01 MANUFACTURERS

- A. Subject to compliance with requirements, manufacturers offering prefinished roofing and siding include, but are not limited to the following:
 - 1. Metal Building Components, Inc.

2.02 SHEET MATERIALS

- A. Steel for Prefinishing: Hot dipped galvanized sheet steel, ASTM 446, G-90 zinc coating.

2.03 METAL FINISHES

- A. Fluoropolymer Coating: Prefinish panels with full strength coating baked-on for 15 minutes at 450 degrees Fahrenheit, in a dry film thickness of 0.9 mil, 30% reflective gloss (ASTM D523), over min. 0.25 mil baked-on modified epoxy primer.
- B. Fasteners: Manufacturer's standard noncorrosive types, with gasketed heads for exposed fasteners.
- C. Color: As selected by the Architect, from "Dexstar 500". Color charts, and galvalume finish as indicated in interior elevations.

2.04 PANEL FABRICATION

- A. Fabricate and finish panels and accessories at the factory to greatest extent possible. Comply with indicated profiles and dimensional requirements, and with structural requirements.
- B. Panels shall be 24 gauge.
- C. Water Penetration: No significant, uncontrolled leakage at 4 lbs. per square foot pressure with spray test.

PART 3 - EXECUTION

3.01 INSTALLATION

- A. Comply with panel fabricator's and material manufacturers' instructions and recommendations for installation, as applicable to project conditions and supporting substrates. Anchor panels and components of the work securely in place, with provisions for thermal/structural movement.
- B. Install panels with exposed or concealed fasteners as required by panel type.

END OF SECTION

SECTION 07461- FIBER-CEMENT SIDING, TRIM AND PANELS

PART 1 - GENERAL

1.01 RELATED DOCUMENTS

- A. Drawings and general provisions of the Contract, including General and Supplementary Conditions and Division 1 Specification Sections, apply to this Section.

1.02 SECTION INCLUDES

- A. Fiber cement lap siding, vertical siding, trim, baten boards, soffit panels and accessories.

1.03 RELATED SECTIONS

- A. Division 5 Section "Cold-Formed Metal Framing" for wall framing and bracing.
- B. Division 6 Section "Rough Carpentry" for wood framing and bracing.
- C. Division 7 Section "Insulation" for exterior wall insulation.

1.04 REFERENCES

- A. ASTM C1186 - Standard Specification for Flat Fiber-Cement Sheets
- B. ASTM D3359 - Standard Test Method for Measuring Adhesion by Tape Test, Tool and Tape.
- C. ASTM E136 - Standard Test Method for Behavior of Materials in a Vertical Tube Furnace at 750 degrees C.

1.05 SUBMITTALS

- A. Submit under provisions of Division 1 section "Submittal Procedures".
- B. Submit Manufacturer's data sheets on each product to be used, including:
 - 1. Preparation instructions and recommendations.
 - 2. Storage and handling requirements and recommendations.
 - 3. Installation methods.
- C. Submit shop Drawings. Provide detailed drawings of atypical non-standard applications of cementitious siding materials which are outside the scope of the standard details and specifications provided by the manufacturer.
- D. Submit verification samples for each finish product specified, two samples, minimum size 4 by 6 inches, representing actual product, color, and patterns.

1.06 QUALITY ASSURANCE

- A. Installer shall have a minimum of 2 years experience with installation of similar products.
- B. Provide a mock-up for evaluation of surface preparation techniques and application workmanship.
 - 1. Finish areas designated by Architect.
 - 2. Do not proceed with remaining work until workmanship, color, and sheen are approved by Architect.
 - 3. Refinish mock-up area as required to produce acceptable work.

1.07 DELIVERY, STORAGE, AND HANDLING

- A. Store products in manufacturer's unopened packaging until ready for installation.
- B. Store siding on edge or lay flat on a smooth level surface. Protect edges and corners from chipping. Store sheets under cover and keep dry prior to installing.
- C. Store and dispose of solvent-based materials, and materials used with solvent-based materials, in accordance with requirements of local authorities having jurisdiction.

1.08 PROJECT CONDITIONS

- A. Maintain environmental conditions (temperature, humidity, and ventilation) within limits recommended by manufacturer for optimum results. Do not install products under environmental conditions outside manufacturer's absolute limits.

1.09 WARRANTY

- A. Provide limited, non-pro-rated product warranty.
 - 1. Siding and panels: 30 years.
 - 2. Trim boards: 15 years.
- B. Workmanship Warranty: Application limited warranty for 2 years.

PART 2 - PRODUCTS

2.01 MANUFACTURERS

- A. Acceptable Manufacturer: James Hardie Building Products, Inc., which is located at: 26300 La Alameda Suite 400 ; Mission Viejo, CA 92691; Toll Free Tel: 866-274-3464; Tel: 949-367-4980; Fax: 949-367-4981; Email: [request info \(info@jameshardie.com\)](mailto:info@jameshardie.com); Web: www.jameshardiecommercial.com
- B. Requests for approval of equal substitutions will be considered in accordance with provisions of Section 01600.

2.02 PRODUCTS

- A. Materials shall meet the requirements listed below.
 - 1. Fiber-cement Siding - complies with ASTM C 1186 Type A Grade II.
 - 2. Fiber-cement Siding - complies with ASTM E 136 as a noncombustible material.
 - 3. Fiber-cement Siding - complies with ASTM E 84 Flame Spread Index of 0, Smoke Developed Index of 5.
 - 4. CAL-FIRE, Fire Engineering Division Building Materials Listing - Wildland Urban Interface (WUI) Listed Product.
 - 5. National Evaluation Report No. NER 405 (BOCA, ICBO, SBCCI, IBC, IRC).
 - 6. City of Los Angeles, Research Report No. 24862.
 - 7. Miami Dade County, Florida Notice of Acceptance 07-0418.04.
 - 8. US Department of Housing and Urban Development Materials Release 1263d.
 - 9. California DSA PA-019.
 - 10. City of New York M EA 223-93-M.
 - 11. Florida State Product Approval FL889.
 - 12. Texas Department of Insurance Product Evaluation EC-23.
- B. Lap siding: Artisan HZ5 Lap Siding.

- C. Vertical siding: HardiePanel HZ5 siding.
- D. Trim: HardieTrim HZ5 boards and Hardie Trim HZ5 Fascia boards.
- E. Soffit panels: Hardie Beaded Porch Panel boards.
- F. Battens: HardieTrim Batten Boards
- G. Type, size and finish of all products shall be as shown on Drawings.

2.03 FASTENERS

- A. Cold Formed Metal Framing: stainless steel.

2.04 FINISHES

- A. Factory Primer: Provide factory applied universal primer.
 - 1. Primer: Factory primed by James Hardie.
 - 2. Topcoat: Refer to Division 9 Section "Painting" and Exterior Finish Schedule.

PART 3 - EXECUTION

3.01 EXAMINATION

- A. Do not begin installation until substrates have been properly prepared.
- B. If framing preparation is the responsibility of another installer, notify Architect of unsatisfactory preparation before proceeding.
- C. Repair any punctures or tears in the water-resistive barrier prior to the installation of the siding.
- D. Protect siding from other trades.

3.02 PREPARATION

- A. Clean surfaces thoroughly prior to installation.
- B. Prepare surfaces using the methods recommended by the manufacturer for achieving the best result for the substrate under the project conditions.

3.03 INSTALLATION OF HORIZONTAL SIDING

- A. Install materials in strict accordance with manufacturer's installation instructions.
- B. Starting: Install a minimum 1/4 inch (6 mm) thick lath starter strip at the bottom course of the wall. Apply planks horizontally with minimum 1-1/4 inches (32 mm) wide laps at the top. The bottom edge of the first plank overlaps the starter strip.
- C. Allow minimum vertical clearance between the edge of siding and any other material in strict accordance with the manufacturer's installation instructions.
- D. Align vertical joints of the planks over framing members.
- E. Maintain clearance between siding and adjacent finished grade.
- F. Locate splices at least one stud cavity away from window and door openings.
- G. Wind Resistance: Where a specified level of wind resistance is required Hardieplank lap siding is installed to framing members and secured with fasteners described in Table No. 2 in National Evaluation Service Report No. NER-405.
- H. Locate splices at least 12 inches (305 mm) away from window and door openings.

3.04 INSTALLATION OF VERTICAL SIDING

- A. Install materials in strict accordance with manufacturer's installation instructions.
- B. Block framing between studs where HardiePanel siding horizontal joints occur.
- C. Install metal Z flashing and provide a 1/4 inch (6 mm) gap at horizontal panel joints.
- D. Place fasteners no closer than 3/8 inch (9.5 mm) from panel edges and 2 inches (51 mm) from panel corners.
- E. Allow minimum vertical clearance between the edge of siding and any other material in strict accordance with the manufacturer's installation instructions.
- F. Maintain clearance between siding and adjacent finished grade.
- G. Specific framing and fastener requirements refer to Tables 2 and 3 in National Evaluation Service Report No. NER-405.

3.05 INSTALLATION OF TRIM BOARDS

- A. Install materials in strict accordance with manufacturer's installation instructions. Install flashing around all wall openings.
- B. Fasten through trim into structural framing or code complying sheathing. Fasteners must penetrate minimum 3/4 inch (19 mm) or full thickness of sheathing. Additional fasteners may be required to ensure adequate security.
- C. Place fasteners no closer than 3/4 inch (19 mm) and no further than 2 inches (51 mm) from side edge of trim board and no closer than 1 inch (25 mm) from end. Fasten maximum 16 inches (406 mm) on center.
- D. Maintain clearance between trim and adjacent finished grade.
- E. Trim inside corner with a single board trim both side of corner.
- F. Outside Corner Board Attach Trim on both sides of corner with 16 gage corrosion resistant finish nail 1/2 inch (13 mm) from edge spaced 16 inches (406 mm) apart, weather cut each end spaced minimum 12 inches (305 mm) apart.
- G. Allow 1/8 inch gap between trim and siding.
- H. Seal gap with high quality, paint-able caulk.
- I. Shim frieze board as required to align with corner trim..
- J. Fasten through overlapping boards. Do not nail between lap joints.
- K. Overlay siding with single board of outside corner board then align second corner board to outside edge of first corner board. Do not fasten HardieTrim boards to HardieTrim boards.
- L. Shim frieze board as required to align with corner trim.
- M. Install HardieTrim Fascia boards to rafter tails or to sub fascia.

3.06 FINISHING

- A. Finish factory primed siding with a minimum of one coat of high quality 100 percent acrylic or latex or oil based exterior grade paint within 180 days of installation. Follow paint manufacturer's written product recommendation and written application instructions.

3.07 PROTECTION

- A. Protect installed products until completion of project.
- B. Touch-up, repair or replace damaged products before Substantial Completion.

END OF SECTION

07620 - SHEET METAL FLASHING AND TRIM

PART 1 - GENERAL

1.01 RELATED DOCUMENTS

- A. Drawings and general provisions of the Contract, including General and Supplementary Conditions and Division 1 Specification Sections, apply to this Section.

1.02 SUMMARY

- A. Section includes the following sheet metal flashing and trim:
 - 1. Formed roof drainage system.
 - 2. Formed low-slope roof flashing and trim.
 - 3. Formed wall flashing and trim.
- B. Related Sections include:
 - 1. Division 6 Section "Rough Carpentry" for wood nailers, curbs, and blocking.
 - 2. Division 7 Section "Sheet Metal Roofing" for custom-formed sheet metal roofing and flashing and trim not part sheet metal flashing and trim.
 - 3. Division 7 Section "Joint Sealants" for field-applied sheet metal flashing and trim sealants.

1.03 PERFORMANCE REQUIREMENTS

- A. Install sheet metal flashing and trim to withstand wind loads, structural movement, thermally induced movement, and exposure to weather without failing, rattling, leaking, and fastener disengagement.
- B. Fabricate and install roof edge flashing capable of resisting the following forces according to recommendations in FMG Loss Prevention Data Sheet 1-49:
 - 1. Wind Zone 2: For velocity pressures of 21 to 30 lbf/sq. ft.: 60-lbf/sq. ft. perimeter uplift force, 90-lbf/sq. ft. corner uplift force, and 30-lbf/sq. ft. outward force.
- C. Provide sheet metal flashing and trim that allow for thermal movements resulting from the following maximum change (range) in ambient and surface temperatures by preventing buckling, opening of joints, hole elongation, overstressing of components, failure of joint sealants, failure of connections, and other detrimental effects. Provide clips that resist rotation and avoid shear stress as a result of sheet metal and trim thermal movements. Base engineering calculation on surface temperatures of materials due to both solar heat gain and nighttime-sky heat loss.
 - 1. Temperature Change (Range): 120 deg F, ambient; 180 deg F, material surfaces.
- D. Provide sheet metal flashing and trim that do not allow water infiltration to building interior.

1.04 SUBMITTALS

- A. Submit Manufacturer's Acknowledgement Letter. Follow Division 1 Section "Submittal Procedures."
- B. Submit product data for each type of product indicated. Include construction details, material descriptions, dimensions of individual components and profiles, and finishes.

- C. Samples for Verification: For each type of exposed finish required, prepared on Samples of size indicated below:
1. Sheet Metal Flashing: 12 inches long. Include fasteners, cleats, clips, closures, and other attachments.
 2. Trim: 12 inches long. Include fasteners and other exposed accessories.
 3. Accessories: Full-size Sample.

1.05 QUALITY ASSURANCE

- A. Comply with SMACNA's "Architectural Sheet Metal Manual." Conform to dimensions and profiles shown unless more stringent requirements are indicated.
- B. Before beginning sheet metal work, install required sheet metal items on mockup to comply with Division 1 "Quality Requirements" in location indicated on the Drawings. Mockups are intended to demonstrate aesthetic effects and set quality standards for materials and execution.

1.06 DELIVERY, STORAGE, AND HANDLING

- A. Deliver sheet metal flashing materials and fabrications undamaged. Protect sheet metal flashing and trim materials and fabrications during transportation and handling.
- B. Unload, store, and install sheet metal flashing materials and fabrications in a manner to prevent bending, warping, twisting, and surface damage.
- C. Stack materials on platforms or pallets, covered with suitable weathertight and ventilated covering. Do not store sheet metal flashing and trim materials in contact with other materials that might cause staining, denting, or other surface damage.

1.07 COORDINATION

- A. Coordinate installation of sheet metal flashing and trim with interfacing and adjoining construction to provide a leakproof, secure, and noncorrosive installation.

PART 2 - PRODUCTS

2.01 SHEET METALS

- A. Zinc-Coated (Galvanized) Steel Sheet: ASTM A 653/A 653M, G90 coating designation; structural quality, mill phosphatized for field painting.
- B. Prepainted, Metallic-Coated Steel Sheet: Steel sheet metallic coated by the hot-dip process and prepainted by the coil-coating process to comply with ASTM A 755/A 755M.
1. Zinc-Coated (Galvanized) Steel Sheet: ASTM A 653/A 653M, G90 coating designation; structural quality.
 2. Exposed Finishes: Apply high-performance organic finish. Prepare, pretreat, and apply coating to exposed metal surfaces to comply with coating and resin manufacturers' written instructions.
 - a. Fluoropolymer 2-Coat System: Manufacturer's standard 2-coat, thermocured system consisting of specially formulated inhibitive primer and fluoropolymer color topcoat containing not less than 70 percent polyvinylidene fluoride resin by weight; complying with physical properties and coating performance requirements of AAMA 2605, except as modified below:
 - (1) Humidity Resistance: 2000 hours.

(2) Salt-Spray Resistance: 2000 hours.

b. Color: As selected by Architect from manufacturer's full range.

C. Lead Sheet: ASTM B 749, Type L51121, copper-bearing lead sheet.

2.02 UNDERLAYMENT MATERIALS

A. Felts: ASTM D 226, Type II (No. 30), asphalt-saturated organic felt, nonperforated.

2.03 MISCELLANEOUS MATERIALS

A. Provide materials and types of fasteners, solder, welding rods, protective coatings, separators, sealants, and other miscellaneous items as required for complete sheet metal flashing and trim installation.

B. Fasteners: Wood screws, annular threaded nails, self-tapping screws, self-locking rivets and bolts, and other suitable fasteners designed to withstand design loads.

1. Unless indicated otherwise, all fasteners shall be stainless steel or aluminum.

2. Exposed Fasteners: Heads matching color of sheet metal by means of plastic caps or factory-applied coating.

3. Fasteners for Flashing and Trim: Blind fasteners or self-drilling screws, gasketed, with hex washer head.

4. Blind Fasteners: High-strength aluminum or stainless-steel rivets.

5. Spikes and Ferrules: Same material as gutter; with spike with ferrule matching internal gutter width.

C. Solder for Stainless Steel: ASTM B 32, Grade Sn60, with acid flux of type recommended by stainless-steel sheet manufacturer.

D. Solder for Lead: ASTM B 32, Grade Sn50, 50 percent tin and 50 percent lead.

E. Sealing Tape: Pressure-sensitive, 100 percent solids, polyisobutylene compound sealing tape with release-paper backing. Provide permanently elastic, nonsag, nontoxic, nonstaining tape.

F. Elastomeric Sealant: ASTM C 920, elastomeric silicone polymer sealant; of type, grade, class, and use classifications required to seal joints in sheet metal flashing and trim and remain watertight.

G. Epoxy Seam Sealer: Two-part, noncorrosive, aluminum seam-cementing compound, recommended by aluminum manufacturer for exterior nonmoving joints, including riveted joints.

H. Asphalt Roofing Cement: ASTM D 4586, asbestos free, of consistency required for application.

2.04 FABRICATION, GENERAL

A. Custom fabricate sheet metal flashing and trim to comply with recommendations in SMACNA's "Architectural Sheet Metal Manual" that apply to design, dimensions, metal, and other characteristics of item indicated. Shop fabricate items where practicable. Obtain field measurements for accurate fit before shop fabrication.

B. Fabricate sheet metal flashing and trim in thickness or weight needed to comply with performance requirements, but not less than that specified for each application and metal.

- C. Fabricate sheet metal flashing and trim without excessive oil canning, buckling, and tool marks and true to line and levels indicated, with exposed edges folded back to form hems.
 - 1. Fabricate nonmoving seams in accessories with flat-lock seams.
 - 2. Tin edges to be seamed, form seams, and solder.
- D. Sealed Joints: Form nonexpansion but movable joints in metal to accommodate elastomeric sealant to comply with SMACNA recommendations.
- E. Expansion Provisions: Where lapped or bayonet-type expansion provisions in the Work cannot be used, form expansion joints of intermeshing hooked flanges, not less than 1 inch deep, filled with elastomeric sealant concealed within joints.
- F. Conceal fasteners and expansion provisions where possible on exposed-to-view sheet metal flashing and trim, unless otherwise indicated.
- G. Fabricate cleats and attachment devices from same material as accessory being anchored or from compatible, noncorrosive metal.
 - 1. Thickness: As recommended by SMACNA's "Architectural Sheet Metal Manual" and FMG Loss Prevention Data Sheet 1-49 for application but not less than thickness of metal being secured.

2.05 ROOF DRAINAGE SHEET METAL FABRICATIONS

- A. Hanging Gutters: Fabricate to cross section indicated, complete with end pieces, outlet tubes, and other accessories as required. Fabricate in minimum 96-inch- long sections. Furnish flat-stock gutter spacers and gutter brackets fabricated from same metal as gutters, of size recommended by SMACNA but not less than twice the gutter thickness. Fabricate expansion joints, expansion-joint covers, gutter bead reinforcing bars, and gutter accessories from same metal as gutters.
 - 1. Expansion Joints: Lap type.
 - 2. Accessories: Wire ball downspout strainer.
 - 3. Gutters with Girth up to 15 Inches: Fabricate from the following material:
 - a. Fabricate from galvanized steel, 0.0217 inch thick.
 - b. Prepainted, Metallic-Coated Steel: 0.0217 inch thick.
 - 4. Gutters with Girth 16 to 20 Inches: Fabricate from the following material:
 - a. Galvanized Steel: 0.0276 inch thick.
 - b. Prepainted, Metallic-Coated Steel: 0.0276 inch thick.
 - 5. Gutters with Girth 21 to 25 Inches: Fabricate from the following material:
 - a. Galvanized Steel: 0.0336 inch thick.
 - b. Prepainted, Metallic-Coated Steel: 0.0336 inch thick.
- B. Downspouts: Fabricate rectangular downspouts complete with mitered elbows. Furnish with metal hangers, from same material as downspouts, and anchors.
 - 1. Fabricate downspouts from the following material:
 - a. Prepainted, Metallic-Coated Steel: 0.0217 inch thick.

2.06 LOW-SLOPE ROOF SHEET METAL FABRICATIONS

- A. Counterflashing: Fabricate from the following material:
 - 1. Prepainted, Metallic-Coated Steel: 0.0276 inch (24 ga.) thick.

- B. Flashing Receivers: Fabricate from the following material:
 - 1. Prepainted, Metallic-Coated Steel: 0.0276 inch thick.
- C. Roof-Penetration Flashing: Fabricate from the following material:
 - 1. Prepainted, Metallic-Coated Steel: 0.0276 inch (24 ga.) thick.

2.07 MISCELLANEOUS SHEET METAL FABRICATIONS

- A. Equipment Support Flashing: Fabricate from the following material:
 - 1. Prepainted, Metallic-Coated Steel: 0.0276 inch (24 ga.) thick.

2.08 FINISHES

- A. Comply with NAAMM's "Metal Finishes Manual for Architectural and Metal Products" for recommendations for applying and designating finishes.
- B. Protect mechanical and painted finishes on exposed surfaces from damage by applying a strippable, temporary protective covering before shipping.
- C. Appearance of Finished Work: Variations in appearance of abutting or adjacent pieces are acceptable if they are within one-half of the range of approved Samples. Noticeable variations in the same piece are not acceptable. Variations in appearance of other components are acceptable if they are within the range of approved Samples and are assembled or installed to minimize contrast.

PART 3 - EXECUTION

3.01 EXAMINATION

- A. Examine substrates, areas, and conditions, with Installer present, to verify actual locations, dimensions and other conditions affecting performance of work.
 - 1. Verify that substrate is sound, dry, smooth, clean, sloped for drainage, and securely anchored.
 - 2. Proceed with installation only after unsatisfactory conditions have been corrected.

3.02 INSTALLATION, GENERAL

- A. Anchor sheet metal flashing and trim and other components of the Work securely in place, with provisions for thermal and structural movement. Use fasteners, solder, welding rods, protective coatings, separators, sealants, and other miscellaneous items as required to complete sheet metal flashing and trim system.
 - 1. Torch cutting of sheet metal flashing and trim is not permitted.
- B. Metal Protection: Where dissimilar metals will contact each other or corrosive substrates, protect against galvanic action by painting contact surfaces with bituminous coating or by other permanent separation as recommended by fabricator or manufacturers of dissimilar metals.
 - 1. Underlayment: Where installing metal flashing directly on cementitious or wood substrates, install a course of felt underlayment and cover with a slip sheet or install a course of polyethylene underlayment.
 - 2. Bed flanges in thick coat of asphalt roofing cement where required for waterproof performance.
- C. Install exposed sheet metal flashing and trim without excessive oil canning, buckling, and tool marks.

- D. Install sheet metal flashing and trim true to line and levels indicated. Provide uniform, neat seams with minimum exposure of solder, welds, and elastomeric sealant.
- E. Install sheet metal flashing and trim to fit substrates and to result in watertight performance. Verify shapes and dimensions of surfaces to be covered before fabricating sheet metal.
 - 1. Space cleats not more than 12 inches apart. Anchor each cleat with two fasteners. Bend tabs over fasteners.
- F. Expansion Provisions: Provide for thermal expansion of exposed flashing and trim. Space movement joints at a maximum of 10 feet with no joints allowed within 24 inches of corner or intersection. Where lapped or bayonet-type expansion provisions cannot be used or would not be sufficiently watertight, form expansion joints of intermeshing hooked flanges, not less than 1 inch deep, filled with elastomeric sealant concealed within joints.
- G. Fasteners: Use fasteners of sizes that will penetrate substrate not less than 1-1/4 inches for nails and not less than 3/4 inch for wood screws.
 - 1. Galvanized or Prepainted, Metallic-Coated Steel: Use stainless-steel fasteners.
 - 2. Copper Use copper or stainless-steel fasteners.
 - 3. Stainless Steel: Use stainless-steel fasteners.
- H. Seal joints with elastomeric sealant as required for watertight construction.
 - 1. Where sealant-filled joints are used, embed hooked flanges of joint members not less than 1 inch into sealant. Form joints to completely conceal sealant. When ambient temperature at time of installation is moderate, between 40 and 70 deg F, set joint members for 50 percent movement either way. Adjust setting proportionately for installation at higher ambient temperatures. Do not install sealant-type joints at temperatures below 40 deg F.
 - 2. Prepare joints and apply sealants to comply with requirements in Division 7 Section "Joint Sealants."
- I. Soldered Joints: Clean surfaces to be soldered, removing oils and foreign matter. Pretin edges of sheets to be soldered to a width of 1-1/2 inches except where pretinned surface would show in finished Work.
 - 1. Do not solder prepainted, metallic-coated steel sheet.
 - 2. Pretinning is not required for lead.
 - 3. Stainless-Steel Soldering: Pretin edges of uncoated sheets to be soldered using solder recommended for stainless steel and phosphoric acid flux. Promptly wash off acid flux residue from metal after soldering.
 - 4. Where surfaces to be soldered are lead coated, do not tin edges, but wire brush lead coating before soldering.
 - 5. Do not use open-flame torches for soldering. Heat surfaces to receive solder and flow solder into joints. Fill joints completely. Completely remove flux and spatter from exposed surfaces.

3.03 ROOF DRAINAGE SYSTEM INSTALLATION

- A. Install sheet metal roof drainage items to produce complete roof drainage system according to SMACNA recommendations and as indicated. Coordinate installation of roof perimeter flashing with installation of roof drainage system.

- B. Hanging Gutters: Join sections with riveted and soldered joints or with lapped joints sealed with elastomeric sealant. Provide for thermal expansion. Attach gutters at eave or fascia to firmly anchored straps spaced not more than 36 inches apart. Provide end closures and seal watertight with sealant. Slope to downspouts.
 - 1. Fasten gutter spacers to front and back of gutter.
 - 2. Loosely lock straps to front gutter bead and anchor to roof deck.
 - 3. Anchor and loosely lock back edge of gutter to continuous cleat, eave or apron flashing.
 - 4. Anchor back of gutter that extends onto roof deck with cleats spaced not more than 24 inches apart.
 - 5. Install gutter with expansion joints at locations indicated but not exceeding 50 feet apart. Install expansion joint caps.
- C. Downspouts: Join sections with 1-1/2-inch telescoping joints. Provide fasteners designed to hold downspouts securely 1 inch away from walls; locate fasteners at top and bottom and at approximately 60 inches o.c. in between.
 - 1. Connect downspouts to underground drainage system indicated.
- D. Expansion-Joint Covers: Install expansion-joint covers at locations and of configuration indicated. Lap joints a minimum of 4 inches in direction of water flow.

3.04 ROOF FLASHING INSTALLATION

- A. Install sheet metal roof flashing and trim to comply with performance requirements and SMACNA's "Architectural Sheet Metal Manual." Provide concealed fasteners where possible, set units true to line, and level as indicated. Install work with laps, joints, and seams that will be permanently watertight.
- B. Roof Edge Flashing: Anchor to resist uplift and outward forces according to recommendations in FMG Loss Prevention Data Sheet 1-49 for specified wind zone and as indicated.
 - 1. Interlock bottom edge of roof edge flashing with continuous cleats anchored to substrate at 16-inch centers.
- C. Pipe or Post Counterflashing: Install counterflashing umbrella with close-fitting collar with top edge flared for elastomeric sealant, extending a minimum of 4 inches over base flashing. Install stainless-steel draw band and tighten.
- D. Counterflashing: Coordinate installation of counterflashing with installation of base flashing. Insert counterflashing in reglets or receivers and fit tightly to base flashing. Extend counterflashing 4 inches over base flashing. Lap counterflashing joints a minimum of 4 inches and bed with elastomeric sealant.
 - 1. Secure in a waterproof manner by means of snap-in installation and sealant or lead wedges and sealant.
 - 2. Secure in a waterproof manner by means of interlocking folded seam or blind rivets and sealant.
 - 3. Secure in a waterproof manner by means of anchor and washer at 36-inch centers.
- E. Coordinate installation of roof-penetration flashing with installation of roofing and other items penetrating roof. Install flashing as follows:
 - 1. Turn lead flashing down inside vent piping, being careful not to block vent piping with flashing.

2. Seal with elastomeric sealant and clamp flashing to pipes penetrating roof except for lead flashing on vent piping.

3.05 CLEANING AND PROTECTION

- A. Clean exposed metal surfaces of substances that interfere with uniform oxidation and weathering.
- B. Clean and neutralize flux materials. Clean off excess solder and sealants.
- C. Remove temporary protective coverings and strippable films as sheet metal flashing and trim are installed. On completion of installation, clean finished surfaces, including removing unused fasteners, metal filings, pop rivet stems, and pieces of flashing. Maintain in a clean condition during construction.
- D. Replace sheet metal flashing and trim that have been damaged or that have deteriorated beyond successful repair by finish touchup or similar minor repair procedures.

END OF SECTION

SECTION 07920 - JOINT SEALANTS

PART 1 - GENERAL

1.01 RELATED DOCUMENTS

- A. Drawings and general provisions of the Contract, including General and Supplementary Conditions and Division 1 Specification Sections, apply to this Section.

1.02 SUMMARY

- A. Section includes sealants for the following applications, including those specified by reference to this Section:
- B. Section includes sealants for the following applications:
 - 1. Exterior joints in the following vertical surfaces and nontraffic horizontal surfaces:
 - a. Control and expansion joints in tilt-up concrete.
 - b. Control and expansion joints in unit masonry.
 - c. Joints in exterior insulation and finish systems (EIFS).
 - d. Joints between different materials listed above.
 - e. Perimeter joints between materials listed above and frames of doors and windows.
 - f. Control and expansion joints in overhead surfaces.
 - g. Other joints as indicated.
- C. Related Sections include:
 - 1. Division 8 Section "Glazing" for glazing sealants.

1.03 PERFORMANCE REQUIREMENTS

- A. Provide elastomeric joint sealants that establish and maintain watertight and airtight continuous joint seals without staining or deteriorating joint substrates.
- B. Provide joint sealants for interior applications that establish and maintain airtight and water-resistant continuous joint seals without staining or deteriorating joint substrates.

1.04 SUBMITTALS

- A. Submit Manufacturer's Acknowledgement Letter. Follow Division 1 Section "Submittal Procedures."
- B. Submit product data for each joint-sealant product indicated.
- C. Submit samples for verification for each type and color of joint sealant required. Install joint sealants in 1/2-inch-wide joints formed between two 6-inch-long strips of material matching the appearance of exposed surfaces adjacent to joint sealants.
- D. Submit product certificates signed by manufacturers of joint sealants certifying that products furnished comply with requirements and are suitable for the use indicated.
- E. Submit qualification data for firms and persons specified in "Quality Assurance" Article to demonstrate their capabilities and experience. Include lists of completed projects with project names and addresses, names and addresses of architects and owners, and other information specified.

- F. Submit Compatibility and Adhesion Test Reports from sealant manufacturer indicating the following:
 - 1. Materials forming joint substrates and joint-sealant backings have been tested for compatibility and adhesion with joint sealants.
 - 2. Interpretation of test results and written recommendations for primers and substrate preparation needed for adhesion.
- G. Submit product test reports from a qualified testing agency indicating sealants comply with requirements, based on comprehensive testing of current product formulations.

1.05 QUALITY ASSURANCE

- A. Installer Qualifications: An experienced installer who has specialized in installing joint sealants similar in material, design, and extent to those indicated for this Project and whose work has resulted in joint-sealant installations with a record of successful in-service performance.
- B. Source Limitations: Obtain each type of joint sealant through one source from a single manufacturer.
- C. Mockups: Before installing joint sealants, apply elastomeric sealants as follows to verify selections made under sample Submittals and to demonstrate aesthetic effects and qualities of materials and execution:
 - 1. Joints in mockups of assemblies specified in other Sections that are indicated to receive elastomeric joint sealants, which are specified by reference to this Section.
- D. Preinstallation Conference: Conduct conference at Project site to comply with requirements in Division 1 Section "Project Meetings."

1.06 DELIVERY, STORAGE, AND HANDLING

- A. Deliver materials to Project site in original unopened containers or bundles with labels indicating manufacturer, product name and designation, color, expiration date, pot life, curing time, and mixing instructions for multicomponent materials.
- B. Store and handle materials in compliance with manufacturer's written instructions to prevent their deterioration or damage due to moisture, high or low temperatures, contaminants, or other causes.

1.07 PROJECT CONDITIONS

- A. Environmental Limitations: Do not proceed with installation of joint sealants under the following conditions:
 - 1. When ambient and substrate temperature conditions are outside limits permitted by joint sealant manufacturer or are below 40 deg F.
 - 2. When joint substrates are wet.
- B. Joint-Width Conditions: Do not proceed with installation of joint sealants where joint widths are less than those allowed by joint sealant manufacturer for applications indicated.
- C. Joint-Substrate Conditions: Do not proceed with installation of joint sealants until contaminants capable of interfering with adhesion are removed from joint substrates.

PART 2 - PRODUCTS

2.01 PRODUCTS AND MANUFACTURERS

- A. Subject to compliance with requirements, products that may be incorporated into the Work include, but are not limited to, the products specified in Part 4.

2.02 MATERIALS, GENERAL

- A. Provide joint sealants, backings, and other related materials that are compatible with one another and with joint substrates under conditions of service and application, as demonstrated by sealant manufacturer based on testing and field experience.
- B. Colors of exposed joint sealants shall be as selected by Architect from manufacturer's full range for this characteristic.

2.03 ELASTOMERIC JOINT SEALANTS

- A. Elastomeric Sealant Standard: Comply with ASTM C 920 and other requirements indicated for each liquid-applied chemically curing sealant in the Elastomeric Joint-Sealant Schedule at the end of Part 3, including those referencing ASTM C 920 classifications for type, grade, class, and uses.
- B. Additional Movement Capability: Where additional movement capability is specified in the Elastomeric Joint-Sealant Schedule, provide products with the capability, when tested for adhesion and cohesion under maximum cyclic movement per ASTM C 719, to withstand the specified percentage change in the joint width existing at the time of installation and remain in compliance with other requirements of ASTM C 920 for uses indicated.

2.04 LATEX JOINT SEALANTS

- A. Latex Sealant Standard: Comply with ASTM C 834 for each product of this description indicated in the Latex Joint-Sealant Schedule at the end of Part 3.

2.05 JOINT-SEALANT BACKING

- A. Provide sealant backings of material and type that are nonstaining; are compatible with joint substrates, sealants, primers, and other joint fillers; and are approved for applications indicated by sealant manufacturer based on field experience and laboratory testing.
- B. Cylindrical Sealant Backings: ASTM C 1330, of type indicated below and of size and density to control sealant depth and otherwise contribute to producing optimum sealant performance:
 - 1. Type C: Closed-cell material with a surface skin.
 - 2. Type O: Open-cell material.
 - 3. Type B: Bicellular material with a surface skin.
 - 4. Type: Any material indicated above.
- C. Elastomeric Tubing Sealant Backings: Neoprene, butyl, EPDM, or silicone tubing complying with ASTM D 1056, nonabsorbent to water and gas, and capable of remaining resilient at temperatures down to minus 26 deg F. Provide products with low compression set and of size and shape to provide a secondary seal, to control sealant depth, and otherwise contribute to optimum sealant performance.
- D. Bond-Breaker Tape: Polyethylene tape or other plastic tape recommended by sealant manufacturer for preventing sealant from adhering to rigid, inflexible joint-filler materials

or joint surfaces at back of joint where such adhesion would result in sealant failure. Provide self-adhesive tape where applicable.

2.06 MISCELLANEOUS MATERIALS

- A. Primer: Material recommended by joint sealant manufacturer where required for adhesion of sealant to joint substrates indicated, as determined from preconstruction joint-sealant-substrate tests and field tests.
- B. Cleaners for Nonporous Surfaces: Chemical cleaners acceptable to manufacturers of sealants and sealant backing materials, free of oily residues or other substances capable of staining or harming joint substrates and adjacent nonporous surfaces in any way, and formulated to promote optimum adhesion of sealants with joint substrates.
- C. Masking Tape: Nonstaining, nonabsorbent material compatible with joint sealants and surfaces adjacent to joints.

PART 3 - EXECUTION

3.01 EXAMINATION

- A. Examine joints indicated to receive joint sealants, with Installer present, for compliance with requirements for joint configuration, installation tolerances, and other conditions affecting joint-sealant performance.
- B. Proceed with installation only after unsatisfactory conditions have been corrected.

3.02 PREPARATION

- A. Surface Cleaning of Joints: Clean out joints immediately before installing joint sealants to comply with joint sealant manufacturer's written instructions and the following requirements:
 - 1. Remove all foreign material from joint substrates that could interfere with adhesion of joint sealant, including dust, paints (except for permanent, protective coatings tested and approved for sealant adhesion and compatibility by sealant manufacturer), old joint sealants, oil, grease, waterproofing, water repellents, water, surface dirt, and frost.
 - 2. Clean porous joint substrate surfaces by brushing, grinding, blast cleaning, mechanical abrading, or a combination of these methods to produce a clean, sound substrate capable of developing optimum bond with joint sealants. Remove loose particles remaining from above cleaning operations by vacuuming or blowing out joints with oil-free compressed air. Porous joint surfaces include the following:
 - a. Concrete.
 - b. Masonry.
 - 3. Remove laitance and form-release agents from concrete.
 - 4. Clean nonporous surfaces with chemical cleaners or other means that do not stain, harm substrates, or leave residues capable of interfering with adhesion of joint sealants.
 - a. Metal.
 - b. Glass.
- B. Joint Priming: Prime joint substrates where recommended in writing by joint sealant manufacturer, based on preconstruction joint-sealant-substrate tests or prior experience. Apply primer to comply with joint sealant manufacturer's written instructions. Confine

primers to areas of joint-sealant bond; do not allow spillage or migration onto adjoining surfaces.

- C. Masking Tape: Use masking tape where required to prevent contact of sealant with adjoining surfaces that otherwise would be permanently stained or damaged by such contact or by cleaning methods required to remove sealant smears. Remove tape immediately after tooling without disturbing joint seal.

3.03 MIXING AND APPLICATION OF POLYURETHANE SEALANT

- A. Pour out entire contents of Component B into pail of Component A. Add entire contents of Color-pak into pail and mix with low-speed drill (400-600 rpm) and approved paddle. Mix for 3-5 minutes to achieve a uniform color and consistency. Avoid entrapment of air during mixing.
- B. Joints:
 - 1. Placement Procedure: Prime all substrates as required based upon the recommendations of the manufacturer of the specified product, when field testing indicates need, and when the joints will be subject to immersion after cure, as approved by the Architect.
 - 2. Install approved backer rod or bond breaker tape in all joints subject to thermal movement to prevent three-sided bonding and to set the depth of the sealant at a maximum of 1/2 in., measured at the center point of the joint width. Approval of the backer rod or bond breaker tape shall be made by the Architect.
 - 3. Joints shall be masked to prevent discoloration or application on unwanted areas, as directed by the Architect. If masking tape is used, it shall not be removed before tooling, yet must be removed before the initial cure of the sealant. Do not apply the masking tape until just prior to the sealant application.
 - 4. Install sealant into prepared joints when the joint is at mid-point of its expansion and contraction cycle.
 - a. Self-leveling sealant: Pour or extrude the sealant into the prepared joint in one direction and allow it to flow and level as necessary. Avoid overlapping the sealant to eliminate the entrapment of air.
 - b. Tool as required to properly fill the joint.
 - 5. Adhere to all limitations and cautions for the polyurethane sealant in the manufacturer's printed literature.
- C. Cracks
 - 1. Self-leveling sealant: Pour or extrude the sealant into the prepared crack in one direction and allow it to flow and level as necessary. Avoid overlapping the sealant to eliminate the entrapment of air. Tool as required to properly fill the crack.
 - 2. Adhere to all limitations and cautions for the polyurethane sealant as stated in the manufacturers printed literature.

3.04 INSTALLATION OF JOINT SEALANTS

- A. Comply with joint sealant manufacturer's written installation instructions for products and applications indicated, unless more stringent requirements apply.
- B. Sealant Installation Standard: Comply with recommendations of ASTM C 1193 for use of joint sealants as applicable to materials, applications, and conditions indicated.

- C. Install sealant backings of type indicated to support sealants during application and at position required to produce cross-sectional shapes and depths of installed sealants relative to joint widths that allow optimum sealant movement capability.
 - 1. Do not leave gaps between ends of sealant backings.
 - 2. Do not stretch, twist, puncture, or tear sealant backings.
 - 3. Remove absorbent sealant backings that have become wet before sealant application and replace them with dry materials.
- D. Install bond-breaker tape behind sealants where sealant backings are not used between sealants and back of joints.
- E. Install sealants by proven techniques to comply with the following and at the same time backings are installed:
 - 1. Place sealants so they directly contact and fully wet joint substrates.
 - 2. Completely fill recesses provided for each joint configuration.
 - 3. Produce uniform, cross-sectional shapes and depths relative to joint widths that allow optimum sealant movement capability.
- F. Tooling of Nonsag Sealants: Immediately after sealant application and before skinning or curing begins, tool sealants according to requirements specified below to form smooth, uniform beads of configuration indicated; to eliminate air pockets; and to ensure contact and adhesion of sealant with sides of joint.
 - 1. Remove excess sealants from surfaces adjacent to joint.
 - 2. Use tooling agents that are approved in writing by sealant manufacturer and that do not discolor sealants or adjacent surfaces.
 - 3. Provide concave joint configuration per Figure 5A in ASTM C 1193, unless otherwise indicated.
 - 4. Provide flush joint configuration, per Figure 5B in ASTM C 1193, where indicated.
 - 5. Provide recessed joint configuration, per Figure 5C in ASTM C 1193, of recess depth and at locations indicated.
 - a. Use masking tape to protect adjacent surfaces of recessed tooled joints.

3.05 CLEANING

- A. Clean off excess sealants or sealant smears adjacent to joints as the Work progresses by methods and with cleaning materials approved in writing by manufacturers of joint sealants and of products in which joints occur.

3.06 PROTECTION

- A. Protect joint sealants during and after curing period from contact with contaminating substances and from damage resulting from construction operations or other causes so sealants are without deterioration or damage at time of Substantial Completion. If, despite such protection, damage or deterioration occurs, cut out and remove damaged or deteriorated joint sealants immediately so installations with repaired areas are indistinguishable from the original work.
- B. Uncured polyurethane sealant can be cleaned with an approved solvent. Cured polyurethane sealant can only be removed mechanically.
- C. Leave work area in a neat, clean condition without evidence of spillovers onto adjacent areas.

PART 4 - SEALANT SCHEDULE

4.01 SINGLE-COMPONENT NONSAG URETHANE SEALANT

- A. Where joint sealants of this type are indicated, provide products complying with the following:
1. Products: Provide one of the following
 - a. Sikaflex - 1a; Sika Corporation.
 - b. NP 1; Sonneborn Building Products Div., ChemRex Inc.
 2. Type and Grade: S (single component) and NS (nonsag).
 3. Class: 25.
 4. Uses Related to Exposure: T (traffic) and NT (nontraffic).
 5. Uses Related to Joint Substrates: M, G, A, and, as applicable to joint substrates indicated, O.
 - a. Use O Joint Substrates: Color anodic aluminum, galvanized steel, brick, and ceramic tile
 6. Applications:
 - a. Exterior control and expansion joints in tilt-up concrete.
 - b. Exterior control and expansion joints in unit masonry.
 - c. Joints in glass-fiber-reinforced precast concrete (GFRC).
 - d. Joints in exterior insulation and finish systems (EIFS).
 - e. Exterior window and door perimeters.
 - f. Other exterior joints as indicated.

4.02 LATEX SEALANT

- A. Where joint sealants of this type are indicated, provide products complying with the following:
1. Products: Available products include the following:
 - a. AC-20; Pecora Corporation.
 - b. Sonolac; Sonneborn Building Products Div., ChemRex, Inc.
 - c. Tremflex 834; Tremco.
 2. Applications:
 - a. Interior window and door perimeters.
 - b. Other interior joints as indicated.

END OF SECTION

SECTION 08110 - STEEL DOORS AND FRAMES

PART 1 - GENERAL

1.01 RELATED DOCUMENTS

- A. Drawings and general provisions of the Contract, including General and Supplementary Conditions and Division 1 Specification Sections, apply to this Section.

1.02 SUMMARY

- A. Section includes:
 - 1. Steel doors.
 - 2. Steel door frames.
- B. Related Sections include :
 - 1. Division 8 Section "Door Hardware for door hardware and weather stripping.
 - 2. Division 9 Section "Gypsum Board Assemblies" for spot-grouting frames installed in steel-framed gypsum board partitions.
 - 3. Division 9 Section "Painting" for field painting factory-primed doors and frames.

1.03 DEFINITIONS

- A. Steel Sheet Thicknesses: Thickness dimensions, including those referenced in ANSI A250.8, are minimums as defined in referenced ASTM standards for both uncoated steel sheet and the uncoated base metal of metallic-coated steel sheets.

1.04 SUBMITTALS

- A. Submit manufacturer's acknowledgement letter. Follow Division 1 Section "Submittal Procedures."
- B. Submit product data for each type of door and frame indicated, include door designation, type, level and model, material description, core description, construction details, label compliance, sound ratings, finishes, elevations of each door design, details of doors including vertical and horizontal edge details, frame details for each frame type including dimensioned profiles, details and locations of reinforcement and preparations for hardware, details of each different wall opening condition, details of anchorages, accessories, joints, and connections, coordination of glazing frames and stops with glass and glazing requirements.
- C. Submit door schedule. Use same reference designations indicated on Drawings in preparing schedule for doors and frames.

1.05 QUALITY ASSURANCE

- A. Steel Door and Frame Standard: Comply with ANSI A 250.8, unless more stringent requirements are indicated.

1.06 DELIVERY, STORAGE, AND HANDLING

- A. Deliver doors and frames cardboard-wrapped or crated to provide protection during transit and job storage. Provide additional protection to prevent damage to finish of factory-finished doors and frames.

- B. Inspect doors and frames on delivery for damage, and notify shipper and supplier if damage is found. Minor damages may be repaired provided refinished items match new work and are acceptable to Architect. Remove and replace damaged items that cannot be repaired as directed.
- C. Store doors and frames at building site under cover. Place units on minimum 4-inch-high wood blocking. Avoid using nonvented plastic or canvas shelters that could create a humidity chamber. If door packaging becomes wet, remove cartons immediately. Provide minimum 1/4-inch spaces between stacked doors to permit air circulation.

PART 2 - PRODUCTS

2.01 MANUFACTURERS

- A. Available Manufacturers: Subject to compliance with requirements, manufacturers offering steel doors and frames that may be incorporated into the Work include, but are not limited to, the following:
 - 1. Amweld Building Products, Inc. (972) 231-7448; (800) 333-9914
 - 2. Ceco Door Products; a United Dominion Company (888) 264-7474
 - 3. Republic Builders Products. (800) 733-3667
 - 4. Door Pro (713) 880-8488
 - 5. Pearland Industries (713) 434-9898.
 - 6. Steelcraft; an Ingersoll-Rand Company.

2.02 MATERIALS

- A. Hot-Rolled Steel Sheets: ASTM A 569/A 569M, Commercial Steel (CS), Type B; free of scale, pitting, or surface defects; pickled and oiled.
- B. Cold-Rolled Steel Sheets: ASTM A 366/A 366M, Commercial Steel (CS), or ASTM A 620/A 620M, Drawing Steel (DS), Type B; stretcher-leveled standard of flatness.
- C. Metallic-Coated Steel Sheets: ASTM A 653/A 653M, Commercial Steel (CS), Type B, with an A40 zinc-iron-alloy (galvannealed) coating; stretcher-leveled standard of flatness.
- D. Electrolytic Zinc-Coated Steel Sheet: ASTM A 591/A 591M, Commercial Steel (CS), Class B coating; mill phosphatized; suitable for unexposed applications; stretcher-leveled standard of flatness where used for face sheets.

2.03 DOORS

- A. Provide doors complying with requirements indicated below by referencing ANSI A250.8 for level and model and ANSI A250.4 for physical-endurance level:
 - 1. Level 2 and Physical Performance Level B (Heavy Duty), Model 1 (Full Flush), interlocking seamed edges.

2.04 FRAMES

- A. Provide steel frames for doors that comply with ANSI A250.8 and with details indicated for type and profile. Conceal fastenings, unless otherwise indicated.
- B. Frames of 0.053-inch-thick steel sheet for:
 - 1. Door openings wider than 48 inches.

2. Level 2 steel doors.
- C. Door Silencers: Except on weather-stripped frames, fabricate stops to receive three silencers on strike jambs of single-door frames and two silencers on heads of double-door frames.
 - D. Plaster Guards: Provide 0.016-inch-thick, steel sheet plaster guards or mortar boxes to close off interior of openings; place at back of hardware cutouts where mortar or other materials might obstruct hardware operation.
 - E. Supports and Anchors: Fabricated from not less than 0.042-inch-thick, electrolytic zinc-coated or metallic-coated steel sheet.
 1. Wall Anchors in Masonry Construction: 0.177-inch-diameter, steel wire complying with ASTM A 510 may be used in place of steel sheet.
 - F. Inserts, Bolts, and Fasteners: Manufacturer's standard units. Where zinc-coated items are to be built into exterior walls, comply with ASTM A 153/A 153M, Class C or D as applicable.

2.05 FABRICATION

- A. Fabricate steel door and frame units to comply with ANSI A250.8 and to be rigid, neat in appearance, and free from defects including warp and buckle. Where practical, fit and assemble units in manufacturer's plant. Clearly identify work that cannot be permanently factory assembled before shipment, to assure proper assembly at Project site.
- B. For exterior locations and elsewhere as indicated, fabricate doors, panels, and frames from galvanized metallic-coated steel sheet. Close top and bottom edges of doors flush as an integral part of door construction or by addition of 0.053-inch-thick, metallic-coated steel channels with channel webs placed even with top and bottom edges.
- C. Core Construction: One of the following manufacturer's standard core materials that produce a door complying with SDI standards:
 1. Resin-impregnated kraft/paper honeycomb.
 2. Polyurethane.
 3. Polystyrene.
 4. Vertical steel stiffeners.
 5. Rigid mineral-fiber board.
- D. Clearances for Non-Fire-Rated Doors: Not more than 1/8 inch at jambs and heads, not more than 1/4 inch between pairs of doors and not more than 3/4 inch at bottom.
- E. Single-Acting, Door-Edge Profile: Beveled edge.
- F. Tolerances: Comply with SDI 117, "Manufacturing Tolerances for Standard Steel Doors and Frames."
- G. Fabricate concealed stiffeners, reinforcement, edge channels, louvers, and moldings from either cold- or hot-rolled steel sheet.
- H. Exposed Fasteners: Unless otherwise indicated, provide countersunk flat or oval heads for exposed screws and bolts.
- I. Thermal-Rated (Insulating) Assemblies: At exterior locations and elsewhere as shown or scheduled, provide doors fabricated as thermal-insulating door and frame assemblies and tested according to ASTM C 236 or ASTM C 976 on fully operable door assemblies.
 1. Unless otherwise indicated, provide thermal-rated assemblies with U-value of 0.41 Btu/sq. ft. x h x deg F or better.

- J. Hardware Preparation: Prepare doors and frames to receive mortised and concealed hardware according to final door hardware schedule and templates provided by hardware supplier. Comply with applicable requirements in ANSI A250.6 and ANSI A115 Series specifications for door and frame preparation for hardware.
- K. Frame Construction: Fabricate frames to shape shown.
 - 1. Provide welded frames with temporary spreader bars.
- L. Reinforce doors and frames to receive surface-applied hardware. Drilling and tapping for surface-applied hardware may be done at Project site.
- M. Locate hardware as indicated on Shop Drawings or, if not indicated, according to ANSI A250.8.

2.06 FINISHES

- A. Prime Finish: Manufacturer's standard, factory-applied coat of rust-inhibiting primer complying with ANSI A250.10 for acceptance criteria.

PART 3 - EXECUTION

3.01 INSTALLATION

- A. Install steel doors, frames, and accessories according to Shop Drawings, manufacturer's data, and as specified.
- B. Placing Frames: Comply with provisions in SDI 105, unless otherwise indicated. Set frames accurately in position, plumbed, aligned, and braced securely until permanent anchors are set. After wall construction is completed, remove temporary braces and spreaders, leaving surfaces smooth and undamaged.
 - 1. Except for frames located in existing walls or partitions, place frames before construction of enclosing walls and ceilings.
 - 2. In wood-stud partitions, provide at least three wall anchors per jamb; install adjacent to hinge location on hinge jamb and at corresponding heights on strike jamb. Attach wall anchors to studs with screws.
 - 3. For openings 90 inches or more in height, install an additional anchor at hinge and strike jambs.
- C. Door Installation: Comply with ANSI A250.8. Fit hollow-metal doors accurately in frames, within clearances specified in ANSI A250.8. Shim as necessary to comply with SDI 122 and ANSI/DHI A115.1G.

3.02 ADJUSTING AND CLEANING

- A. Prime-Coat Touchup: Immediately after installation, sand smooth any rusted or damaged areas of prime coat and apply touch up of compatible air-drying primer.
- B. Protection Removal: Immediately before final inspection, remove protective wrappings from doors and frames.

END OF SECTION

SECTION 08161 - FIBERGLASS DOORS AND FRAMES

PART 1 - GENERAL

1.01 RELATED DOCUMENTS

- A. Drawings and general provisions of the Contract, including General and Supplementary Conditions and Division 1 Specification Sections, apply to this Section.

1.02 SCOPE AND DEFINITIONS

- A. Furnish and install doors and frames of FRP composite construction in accordance with details and schedule shown on the Drawings and as specified herein. Door and frame products of aluminum, steel or wood constructions that use FRP face sheets are strictly excluded.
- B. FRP is defined as "Fiberglass Reinforced Polyester"

1.03 RELATED SECTIONS

- A. Division 4 Section "Unit Masonry"
- B. Division 8 Section "Door Hardware"

1.04 QUALITY ASSURANCE

- A. Referenced Standards
 - 1. American Society for Testing and Materials (ASTM)
 - 2. Society of Automotive Engineers (SAE)
 - 3. International Building Code, Plastics (Chapter 26)
- B. Manufacturer shall be ISO 9001 certified and been engaged in the manufacture of FRP door and frame systems for a minimum of five (5) years documented experience prior to the start of this work, and who has a history of successful production acceptable to the Architect.
- C. Certify that FRP doors are manufactured via F.L.O.A.T. method of assembly.
- D. Provide limited written guarantee for FRP doors and frames as follows:
 - 1. Commercial Duty doors shall be guaranteed for the life of the product against failure due to corrosion from the specific chemical environment named at the time of purchase. Furthermore, all products shall be inspected prior to shipment and guaranteed against defective workmanship for a period of ten (10) calendar years after the date of purchase.

1.05 SUBMITTALS

- A. Provide catalog cut of FRP door detailing internal construction and reinforcements, materials used and description of assembly process.
- B. Submit shop drawings to include the following specific information:
 - 1. Specifications relating to FRP door thickness, resin type, core material, method of construction, finish color, type of glass and glazing, anchor systems, joint construction and complete warranty information.
 - 2. Complete schedules or drawings of FRP doors and frames (and associated Builders Hardware) showing identifying mark numbers, door and frame types,

- typical elevations, nominal sizes, handing, actual dimensions and clearances, and required hardware preps and reinforcements.
3. Supporting reference drawings pertaining to frame mounting details, door lite or louver installation, hardware locations, and factory hardware cutouts and reinforcements.
- C. Submit a complete set of available finish colors from the manufacturer for color selection.
 - D. Submit installation instructions. Include manufacturer's specific information describing procedures, sequence and required fasteners for frame and door installation.
 - E. Production of FRP doors and frames shall not proceed until final approval of submittals and all necessary manufacturing information is received from customer.

1.06 DELIVERY, STORAGE AND HANDLING

- A. FRP doors and frames shall be delivered to jobsite in boxes with foam sheet separations.
- B. Upon receipt of shipment, remove and inspect the doors and frames for damage. Note any damage on the shipping papers prior to accepting. If there is any noted (visible or concealed) damage, notify the manufacturer immediately.
- C. Store doors indoors in a vertical position, clear of the floor, with blocking between the doors to permit air circulation between the doors and prevent damage to the door faces. Do not allow rain water or condensation to collect or lay between stored doors. Do not wrap in plastic sheeting.
- D. Use care in handling FRP doors and frames to prevent damage to factory finishes. Wear protective gloves and do not slide or drag doors or frames against one another.

PART 2 - PRODUCTS

2.01 MANUFACTURER

- A. Commercial Duty FRP Doors and Frames shall be as manufactured by Overly/Tiger Door, 574 West Otterman Street, Greensburg, PA 15601, 800-979-7300, fax 724-830-2871, www.tigerdoor.com.
 1. Alternates will be considered.

2.02 FRP DOORS

- A. Commercial Duty Non-fire rated FRP Doors
 1. FRP doors shall be of seamless construction. Laminated FRP face sheets shall be bonded to an internal door stile and rail channel subframe/core assembly. The composite door panel must be bonded over its entire surface area, not just adhesive-bonded at perimeter stiles and rails.
 2. A 1-3/4" wide x 1-1/2" deep x 5/8" web pultruded FRP Channel subframe is to be provided within the door. All connections shall be chemically welded. No mechanical fasteners will be allowed. The use or inclusion of aluminum, steel, gypsum or wood into stile and rail construction is not permitted.
 3. Core shall be a triangular shaped 3/8" cell phenolic resin impregnated kraft paper honeycomb. Molding pressure and adhesive gel time shall be sufficient to allow for penetration of resin into the cellular structure of the core to maximize shear and peel strengths at the skin/core interface. The honeycomb is to be completely

enclosed within the stile and rail subframe. Use of foam or balsa wood is not permitted.

4. Internal reinforcement shall be high-density polymer compression blocks, or plastic compression blocking at all hardware locations. No wood blocking, steel or aluminum reinforcing plates, ribs or fittings shall be used. A minimum of 900 lbs of pullout strength is required for each factory supplied hinge screw.
5. Door facings shall utilize a chemical resistant modified polyester copolymer resin system with fiber reinforcing layers. Supplier shall furnish door faces as shown on the drawings and in the door elevations. Structural reinforcement of the face skin shall be in the form of random chopped fiberglass roving.
6. Exposed FRP door faces shall have a 3-4 mils (wet) factory applied two-part aliphatic polyurethane fully cured coating of industrial urethane. Coating shall have a minimum hardness of H to 2H. Finish shall be slightly textured semi-gloss.

2.03 FRP FRAMES

A. FRP Frames:

1. FRP Door frames shall utilize a high-modulus pultruded structural FRP shape. The frame section shall be standard double rabbeted 5-3/4" deep x 2" face, 3/16" thick, with integral 5/8" doorstop with 1 15/16" soffits, to match typical hollow metal configurations.
2. Frame jambs and header shall be joined at corners via miter connections with hidden FRP angle clips and associated fasteners. Post and beam corners will not be acceptable. Exposed fasteners for miter connections will not be acceptable except for wrap wall applications.
3. FRP reinforcing shall be chemically welded to door frame material at required locations. Minimum screw pullout strength of 1100 lb per #12 x 1" sheet metal screw is required. Mechanically fastened reinforcements are not permitted.
4. Anchors:
 - a. Bolt-In: Provide manufacturer's required number of 3/8" diameter x 4" long flat head stainless steel sleeve anchors for masonry openings, 3/8" diameter x 4" machine screw with nut and washers for structural steel openings, #14 x 4" stainless steel flat head sheet metal screws for wood or steel stud openings. Include extra anchors for additional frame height in two foot increments above 8'-0". Provide single bolt anchor at center of all headers over four feet in nominal width. Stainless Steel fasteners shall be furnished by the factory.
 - b. Grout-In: Provide manufacturer's required number of wire or strap type masonry anchors for installation into block wall. Fill frame cavity with grout.
5. Frames shall have a 3-4 mils (wet) factory applied two-part aliphatic polyurethane fully cured coating of industrial urethane. Industrial urethane chemical coating color topcoat, to match the color and sheen of the doors, for superior weatherability. Gelcoat may not be sprayed onto the frame as a secondary coating.

2.04 MECHANICAL PROPERTIES AND TEST PERFORMANCE

- A. Pultruded structural shapes for stiles; rails, frames, and astragals shall exhibit the following minimum longitudinal coupon properties (per ASTM):
1. Tensile strength (D638) 30,000 psi
 2. Comprehensive strength (D695) 30,000 psi
 3. Flexural strength (D790) 30,000 psi
 4. Flexural modulus (D790) 1,600,000 psi
 5. Shear strength (D2846) 4,500 psi
 6. Impact, notched (D256) 25 ft-lb/in
 7. Barcol hardness (D2853) 50
- B. Core material shall exhibit the following minimum coupon properties (per ASTM):
1. Core material must comply with the International Building Code (IBC) chapter 26 requirements for use with a plastic skin.
 2. Shear strength, longitudinal direction (C273) 68.2 psi
 3. Shear strength, transverse direction (C273) 25.8 psi
 4. Shear modulus, longitudinal direction (C273) 6940 psi
 5. Shear modulus, transverse direction (C273) 1878 psi
 6. Shear elongation, longitudinal direction (C393 short beam) 1.79%
 7. Shear elongation, transverse direction (C393 short beam) 2.72%
 8. Maximum facing stress, longitudinal direction (C393 short beam) 735 psi
 9. Maximum facing stress, transverse direction (C393 short beam) 289 psi
 10. Maximum core shear stress, longitudinal direction (C393 short beam) 63.8 psi
 11. Maximum core shear stress, transverse direction (C393 short beam) 24.9 psi
 12. Modulus of elasticity (EI) per 1" width, longitudinal direction (C393 short beam) 4.92E+04 psi
 13. Modulus of elasticity (EI) per 1" width, transverse direction (C393 short beam) 1.97E+04 psi
 14. Maximum facing stress, longitudinal direction (C393 long beam) 9011 psi
 15. Maximum facing stress, transverse direction (C393 long beam) 4727 psi
 16. Maximum core shear stress, longitudinal direction (C393 long beam) 48.3 psi
 17. Maximum core shear stress, transverse direction (C393 long beam) 23.5psi
 18. Modulus of elasticity (EI) per 1" width, longitudinal direction (C393 long beam) 1.14E+05 psi
 19. Modulus of elasticity (EI) per 1" width, transverse direction (C393 long beam) 7.23E+05 psi
 20. Stiffness "D", longitudinal direction (C393 long beam) 379,270 psi
 21. Stiffness "D", longitudinal direction (C393 long beam) 260,608 psi
 22. Compressive strength (C365) 53 psi
 23. Compressive modulus (C365) 2110 psi
 24. Density (C271) 2.42 lb/ft³
- C. Adhesive for bonding pultrusions shall exhibit the following minimum coupon properties (per SAE)

1. Tensile Strength (D882-83A modified) minimum 2000 psi
2. 8 day 25° C at 100% humidity Cross Peel (SAE J1553) minimum 330 psi
3. 7 day immersion in seawater Cross Peel (SAE J1553) minimum 330 psi
4. 30 day immersion in saltwater Cross Peel (SAE J1553) minimum 330 psi
5. 72 hour immersion in gasoline Cross Peel (SAE J1553) minimum 330 psi
6. 72 hour immersion in 20% sulfuric acid Cross Peel (SAE J1553) minimum 300 psi

2.05 FASTENERS

- A. All fasteners for all hardware shall be type 304 CRSS (18-8 series corrosion resistant stainless steel). No carbon steel or aluminum components shall be used.

2.06 HARDWARE

- A. Doors shall be factory mortised and drilled for mortise template butt hinges, with #12x2" long stainless steel screws provided by Tiger for hinge attachment. Provide 161 cylindrical lock bore, rim deadbolt, ANSI 86 mortise lock edge prep and pocket, or flush bolt cutouts as required.
- B. Frames shall be factory machined and drilled for all hardware requiring mortises, with #12x1" long stainless steel screws pre-installed for hinge attachment.
- C. Hardware shall be furnished per Division 8 Section "Door Hardware" and as shown on Drawings. Hardware shall be installed by experienced installer.
- D. Obtain manufacturer's standard templates, installation instructions, or full size approved door and frame preparation instructions from installer prior to manufacturing doors and frames.

PART 3 - EXECUTION

3.01 IDENTIFICATION

- A. Factory mark all doors and frames using a chemical resistant plastic tag or indelible marker with identifying number, keyed to shop drawings, prior to shipment.

3.02 INSTALLATION

- A. Install frames in strict accordance with manufacturer's printed instructions. Set plumb and square, using shims for bolt-in of existing openings, or wood bracing prior to grouting of jambs. Use at least two 2x6 wood spreaders inside frame to maintain critical opening dimensions during grouting.
- B. Install doors per manufacturer's printed instructions using special screws provided for hinge attachment. Install doors to swing freely and to stand open at any angle. After installation make final adjustments to hardware to allow for proper door operation and latching. All surface applied hardware shall be thru bolted.

3.03 CLEANING

- A. Clean exposed surfaces of FRP doors and frames with a mild, non-abrasive cleaner and water.

END OF SECTION

SECTION 08210 - PLASTIC LAMINATE CLAD WOOD DOORS

PART 1 - GENERAL

1.01 RELATED DOCUMENTS

- A. Drawings and general provisions of the Contract, including General and Supplementary Conditions and Division 1 Specification Sections, apply to this Section.

1.02 SUMMARY

- A. Section includes:
 - 1. Solid-core doors with plastic-laminate faces.
 - 2. Factory fitting flush wood doors to frames and factory machining for hardware.
- B. Related Sections include the following:
 - 1. Division 8 Section "Steel Doors and Frames"
 - 2. Division 8 Section "Door Hardware."
 - 3. Division 8 Section "Glazing" for glass view panels in flush wood doors.

1.03 SUBMITTALS

- A. Submit Manufacturer's Acknowledgement Letter. Follow Division 1 Section "Submittal Procedures".
- B. Submit product data. Include installation instructions, and recommendations for each product and data substantiating that materials comply with specified requirements.
- C. Submit shop drawings. Indicate material type, finish and thickness, door size and installation procedures. Provide color samples for architects selection from manufacturing standard finishes and colors unless instructed otherwise.
- D. Submit maintenance manuals. Provide adequate directions to service and maintain doors as necessary.

1.04 WARRANTY

- A. The work of this Section shall be warranted for one year after erection against becoming unserviceable or objectionable in appearance as a result of being defective or non-conforming. Warrant against defective material and workmanship.
- B. Doors clad with plastic laminate shall be guaranteed against defects in materials and workmanship, including warpage, for the life of the installation.

PART 2 - PRODUCTS

2.01 GENERAL

- A. All doors as indicated, shall be clad with Pionite, Formica or equal brand laminate. These doors shall meet or exceed the quality as specified by National Woodwork Manufacturer's Association industry standards for plastic faced doors. They shall also conform to Architectural Woodwork Institute (AWI) specifications PC-HPDL for Particle Core - High Pressure Laminate Doors.

2.02 MATERIALS AND CONSTRUCTION

- A. Solid Core - Particle Board: Manufactured from a formed flat panel consisting of wood particles bonded together with synthetic resins or other added binder, with a density of 28-32 lbs. per cubic foot. The material shall meet or exceed the requirements of Grade "1-L-1" Particle Board as described in the latest edition of ANSI A208.1, "Mat Formed Wood Particle Board". Cores shall be securely bonded to the stiles and rails. Stiles shall be 1 3/8" and rails shall be 1 1/8" top and bottom. Entire unit shall be sanded to eliminate telegraphing through the veneers.
- B. Stile thickness is a minimum and shall be carefully coordinated with the hardware requirements for the individual doors.
- C. Door edges shall be a closed grain hardwood finished by the manufacturer in a color that matches the laminate on the door face.

2.03 FABRICATION

- A. Light openings and louver openings shall all be made at the factory, and shall be of sizes and locations as indicated on the drawings. All cutouts shall allow a 5" minimum distance to the stile or rail edges of doors. Anodized aluminum glass stops shall be furnished for light openings. Louvers as specified, shall be installed at the factory.
- B. All cutouts for mortise hardware shall be made at the factory from hardware manufacturer templates and physical samples as furnished. Hardware and door frame schedules shall be furnished to door manufacturer as required. Door manufacturer to submit shop drawing for approval.
 - 1. Doors shall be individually cartoned at the factory for protection in transit and shall be marked and tagged with tag numbers of the door per approved shop drawings.

PART 3 - EXECUTION

3.01 STORAGE

- A. Store flat on a level surface in a clean, dry well ventilated area protected from sunlight.
- B. Door should not be stored in areas where humidity exceeds 60% or is less than 30%.
- C. Allow doors to become acclimated to finished building heat and humidity prior to hanging.

END OF SECTION

SECTION 08410 - ALUMINUM-FRAMED ENTRANCES AND STOREFRONTS

PART 1 - GENERAL

1.01 RELATED DOCUMENTS

- A. Drawings and general provisions of the Contract, including General and Supplementary Conditions and Division 1 Specification Sections, apply to this Section.

1.02 SUMMARY

- A. Section includes:
 - 1. Interior and exterior aluminum-framed storefronts where glazing is retained mechanically with gaskets on four sides.
 - 2. Exterior manual-swing aluminum doors.
- B. Related Sections include:
 - 1. Division 7 Section "Joint Sealants" for installation of joint sealants installed with aluminum-framed systems and for sealants to the extent not specified in this Section.
 - 2. Division 8 Section "Door Hardware" for hardware to the extent not specified in this Section.
 - 3. Division 8 Section "Glazing" for glazing requirements to the extent not specified in this Section.

1.03 PERFORMANCE REQUIREMENTS

- A. Provide aluminum-framed systems, including anchorage, capable of withstanding, without failure, the effects of the following:
 - 1. Structural loads.
 - 2. Thermal movements.
 - 3. Movements of supporting structure indicated on Drawings including, but not limited to, story drift and deflection from uniformly distributed and concentrated live loads.
 - 4. Dimensional tolerances of building frame and other adjacent construction.
 - 5. Failure includes the following:
 - a. Deflection exceeding specified limits.
 - b. Thermal stresses transferred to building structure.
 - c. Framing members transferring stresses, including those caused by thermal and structural movements, to glazing.
 - d. Noise or vibration created by wind and thermal and structural movements.
 - e. Loosening or weakening of fasteners, attachments, and other components.
 - f. Sealant failure.
 - g. Failure of operating units to function properly.
 - 6. Wind Loads: 30 lbs. per sq. ft.
- B. Deflection of Framing Members:

1. Deflection normal to wall plane shall be limited to:
 - a. 1/175 of clear span for spans up to 13 feet 6 inches.
 - b. 1/240 of clear span plus 1/4 inch for spans greater than 13 feet 6 inches.
 - c. Or an amount that restricts edge deflection of individual glazing lites to 3/4 inch, whichever is less.
 2. Deflection parallel to glazing plane shall be limited to amount not exceeding that which reduces glazing bite to less than 75 percent of design dimension and that which reduces edge clearance between framing members and glazing or other fixed components directly below to less than 1/8 inch and clearance between members and operable units directly below to less than 1/16 inch.
- C. Structural-Test Performance: Provide aluminum-framed systems tested according to ASTM E 330 as follows:
1. When tested at positive and negative wind-load design pressures, systems do not evidence deflection exceeding specified limits.
 2. When tested at 150 percent of positive and negative wind-load design pressures, systems, including anchorage, do not evidence material failures, structural distress, and permanent deformation of main framing members exceeding 0.2 percent of span.
 3. Test Durations: As required by design wind velocity but not less than 10 seconds.
- D. Thermal Movements: Provide aluminum-framed systems that allow for thermal movements resulting from the following maximum change (range) in ambient and surface temperatures. Base engineering calculation on surface temperatures of materials due to both solar heat gain and nighttime-sky heat loss.
1. Temperature Change (Range): 120 deg F, ambient; 180 deg F, material surfaces.
- E. Air Infiltration: Provide aluminum-framed systems with maximum air leakage as follows:
1. Through Fixed Glazing and Framing Areas: 0.06 cfm/sq. ft. of fixed wall area when tested according to ASTM E 283 at a minimum static-air-pressure difference of 1.57 lbf/sq. ft.
 2. Through Entrance Areas: 1.75 cfm/sq. ft. of fixed wall area when tested according to ASTM E 283 at a minimum static-air-pressure difference of 1.57 lbf/sq. ft.
- F. Water Penetration Under Static Pressure: Provide aluminum-framed systems that do not evidence water penetration through fixed glazing and framing areas when tested according to ASTM E 331 at a minimum static-air-pressure difference of 20 percent of positive wind-load design pressure, but not less than 6.24 lbf/sq. ft.
- G. Average Thermal Conductance: Provide aluminum-framed systems with fixed glazing and framing areas having average U-factor of not more than 0.69 Btu/sq. ft. x h x deg F when tested according to AAMA 1503.

1.04 SUBMITTALS

- A. Submit product data. Include construction details, material descriptions, dimensions of individual components and profiles, and finishes for each type of product indicated.
- B. Submit shop drawings. Include plans, elevations, sections, details, and attachments to other work.

1. Include structural analysis data signed and sealed by the qualified professional engineer responsible for their preparation.
 2. Include details of provisions for system expansion and contraction and for draining moisture occurring within the system to the exterior.
 3. For entrances, include hardware schedule and indicate operating hardware types, functions, quantities, and locations.
- C. Submit samples for verification for each type of exposed finish required, in manufacturer's standard sizes.
- D. Submit fabrication sample of each vertical-to-horizontal intersection of systems, made from 12-inch lengths of full-size components and showing details of the following:
1. Joinery.
 2. Anchorage.
 3. Expansion provisions.
 4. Glazing.
 5. Flashing and drainage.
- E. Submit product test reports based on evaluation of comprehensive tests performed by a qualified testing agency, for aluminum-framed systems.
- F. Submit maintenance data for aluminum-framed systems to include in maintenance manuals.
- G. Submit special warranties specified in this Section.

1.05 QUALITY ASSURANCE

- A. Installer Qualifications: Capable of assuming engineering responsibility and performing work of this Section and who is acceptable to manufacturer.
1. Engineering Responsibility: Preparation of data for aluminum-framed systems including Shop Drawings based on testing and engineering analysis of manufacturer's standard units in assemblies similar to those indicated for this Project and submission of reports of tests performed on manufacturer's standard assemblies.
- B. Product Options: Information on Drawings and in Specifications establishes requirements for systems' aesthetic effects and performance characteristics. Aesthetic effects are indicated by dimensions, arrangements, alignment, and profiles of components and assemblies as they relate to sightlines, to one another, and to adjoining construction. Performance characteristics are indicated by criteria subject to verification by one or more methods including preconstruction testing, field testing, and in-service performance.
1. Do not modify intended aesthetic effects, as judged solely by Architect, except with Architect's approval. If modifications are proposed, submit comprehensive explanatory data to Architect for review.
- C. Source Limitations: Obtain framing systems and entrances (doors) through one source from a single manufacturer.
- D. Entrances shall comply with "Texas Accessibility Standards (TAS).

1.06 PROJECT CONDITIONS

- A. Field Measurements: Verify actual locations of structural supports for aluminum-framed systems by field measurements before fabrication and indicate measurements on Shop Drawings.

1.07 WARRANTY

- A. Special Assembly Warranty: Manufacturer's standard form in which manufacturer agrees to repair or replace components of aluminum-framed systems that do not comply with requirements or that deteriorate as defined in this Section within specified warranty period.
 - 1. Failures include, but are not limited to, the following:
 - a. Structural failures including, but not limited to, excessive deflection.
 - b. Noise or vibration caused by thermal movements.
 - c. Deterioration of metals, metal finishes, and other materials beyond normal weathering.
 - d. Water leakage through fixed glazing and framing areas.
 - e. Failure of operating components to function properly.
 - 2. Warranty Period: Two years from date of Substantial Completion.

PART 2 - PRODUCTS

2.01 MANUFACTURERS

- A. Basis-of-Design Product:
 - 1. Aluminum-Framed Systems with Insulated Glazing Units: Design is based on "IR 501" by Kawneer. Subject to compliance with requirements, provide the named product or a comparable product by one of the following:
 - a. Vistawall Architectural Products.
 - b. YKK AP America Inc.

2.02 MATERIALS

- A. Aluminum: Alloy and temper recommended by manufacturer for type of use and finish indicated.
 - 1. Sheet and Plate: ASTM B 209.
 - 2. Extruded Bars, Rods, Profiles, and Tubes: ASTM B 221.
 - 3. Extruded Structural Pipe and Tubes: ASTM B 429.
 - 4. Structural Profiles: ASTM B 308/B 308M.
 - 5. Welding Rods and Bare Electrodes: AWS A5.10/A5.10M.
- B. Steel Reinforcement: With manufacturer's standard corrosion-resistant primer complying with SSPC-PS Guide No. 12.00 applied immediately after surface preparation and pretreatment. Select surface preparation methods according to recommendations in SSPC-SP COM and prepare surfaces according to applicable SSPC standard.
 - 1. Structural Shapes, Plates, and Bars: ASTM A 36/A 36M.
 - 2. Cold-Rolled Sheet and Strip: ASTM A 1008/A 1008M.
 - 3. Hot-Rolled Sheet and Strip: ASTM A 1011/A 1011M.

2.03 FRAMING SYSTEMS

- A. Framing Members: Manufacturer's standard extruded-aluminum framing members of thickness required and reinforced as required to support imposed loads.
 - 1. Construction: Thermal break; high-performance plastic connectors separate framing members exposed to the exterior from members exposed to the interior.
 - 2. Provide high-performance sills with end dams.
- B. Brackets and Reinforcements: Manufacturer's standard high-strength aluminum with nonstaining, nonferrous shims for aligning system components.
- C. Fasteners and Accessories: Manufacturer's standard corrosion-resistant, nonstaining, nonbleeding fasteners and accessories compatible with adjacent materials.
 - 1. Where fasteners are subject to loosening or turning out from thermal and structural movements, wind loads, or vibration, use self-locking devices.
 - 2. Reinforce members as required to receive fastener threads.
- D. Flashing: Manufacturer's standard corrosion-resistant, nonstaining, nonbleeding flashing compatible with adjacent materials. Form exposed flashing from sheet aluminum finished to match framing and of sufficient thickness to maintain a flat appearance without visible deflection.
- E. Framing System Gaskets and Sealants: Manufacturer's standard recommended by manufacturer for joint type.

2.04 GLAZING SYSTEMS

- A. Glazing: Glazing units indicated as specified in Division 8 Section "Glazing."
- B. Glazing Gaskets: Manufacturer's standard compression types, replaceable, molded or extruded, that maintain uniform pressure and watertight seal.
- C. Spacers and Setting Blocks: Manufacturer's standard elastomeric types.

2.05 DOORS

- A. Provide manufacturer's standard glazed doors, for manual swing operation.
 - 1. Door Construction: 1-3/4-inch overall thickness, with minimum 0.125-inch-thick, extruded-aluminum tubular rail and stile members. Mechanically fasten corners with reinforcing brackets that are deep penetration and fillet welded.
 - a. Basis of Design: Kawneer "350 Standard Aluminum Entrance."
 - b. Doors shall be smooth surfaced for width of door in area within 10 inches above floor or ground plane.
 - 2. Glazing: 1/4-inch tempered glass as specified in Division 8 Section "Glazing."
 - 3. Glazing Stops and Gaskets: Square, snap-on, extruded-aluminum stops and preformed gaskets.

2.06 DOOR HARDWARE

- A. Door hardware is specified in Division 8 Section "Door Hardware."

2.07 ACCESSORY MATERIALS

- A. Joint Sealants: For installation at perimeter of aluminum-framed systems, as specified in Division 7 Section "Joint Sealants."
- B. Bituminous Paint: Cold-applied asphalt-mastic paint complying with SSPC-Paint 12 requirements except containing no asbestos, formulated for 30-mil thickness per coat.

2.08 FABRICATION

- A. Form aluminum shapes before finishing.
- B. Weld in concealed locations to greatest extent possible to minimize distortion or discoloration of finish. Remove weld spatter and welding oxides from exposed surfaces by descaling or grinding.
- C. Fabricate components that, when assembled, have the following characteristics:
 - 1. Profiles that are sharp, straight, and free of defects or deformations.
 - 2. Accurately fitted joints with ends coped or mitered.
 - 3. Means to drain water passing joints, condensation occurring within framing members, and moisture migrating within the system to exterior.
 - 4. Physical and thermal isolation of glazing from framing members.
 - 5. Accommodations for thermal and mechanical movements of glazing and framing to maintain required glazing edge clearances.
 - 6. Provisions for field replacement of glazing from exterior.
 - 7. Fasteners, anchors, and connection devices that are concealed from view to greatest extent possible.
- D. Mechanically Glazed Framing Members: Fabricate for flush glazing (without projecting stops).
- E. Door Frames: Reinforce as required to support loads imposed by door operation and for installing hardware.
 - 1. At exterior doors, provide compression weather stripping at fixed stops.
- F. Doors: Reinforce doors as required for installing hardware.
 - 1. At pairs of exterior doors, provide sliding weather stripping retained in adjustable strip mortised into door edge.
 - 2. At exterior doors, provide weather sweeps applied to door bottoms.
- G. Hardware Installation: Factory install hardware to the greatest extent possible. Cut, drill, and tap for factory-installed hardware before applying finishes.
- H. After fabrication, clearly mark components to identify their locations in Project according to Shop Drawings.

2.09 ALUMINUM FINISHES

- A. Comply with NAAMM's "Metal Finishes Manual for Architectural and Metal Products" for recommendations for applying and designating finishes.
- B. Finish designations prefixed by AA comply with the system established by the Aluminum Association for designating aluminum finishes.
- C. Class I, Clear Anodic Finish: AA-M12C22A41 (Mechanical Finish: nonspecular as fabricated; Chemical Finish: etched, medium matte; Anodic Coating: Architectural Class I, clear coating 0.018 mm or thicker) complying with AAMA 611.

PART 3 - EXECUTION

3.01 EXAMINATION

- A. Examine areas, with Installer present, for compliance with requirements for installation tolerances and other conditions affecting performance of work.

- B. Proceed with installation only after unsatisfactory conditions have been corrected.

3.02 INSTALLATION

A. General:

1. Comply with manufacturer's written instructions.
2. Do not install damaged components.
3. Fit joints to produce hairline joints free of burrs and distortion.
4. Rigidly secure nonmovement joints.
5. Install anchors with separators and isolators to prevent metal corrosion and electrolytic deterioration.
6. Seal joints watertight, unless otherwise indicated.

B. Metal Protection:

1. Where aluminum will contact dissimilar metals, protect against galvanic action by painting contact surfaces with primer or by applying sealant or tape or installing nonconductive spacers as recommended by manufacturer for this purpose.
2. Where aluminum will contact concrete or masonry, protect against corrosion by painting contact surfaces with bituminous paint.

- C. Install components to drain water passing joints, condensation occurring within framing members, and moisture migrating within the system to exterior.

- D. Set continuous sill members and flashing in full sealant bed as specified in Division 7 Section "Joint Sealants" and to produce weathertight installation.

- E. Install components plumb and true in alignment with established lines and grades, without warp or rack.

- F. Install glazing as specified in Division 8 Section "Glazing."

- G. Entrances: Install to produce smooth operation and tight fit at contact points.

1. Exterior Entrances: Install to produce tight fit at weather stripping and weathertight closure.
2. Set thresholds in full sealant bed as specified in Division 7 Section "Joint Sealants" and to produce weathertight installation.
3. Field-Installed Hardware: Install surface-mounted hardware according to hardware manufacturers' written instructions using concealed fasteners to greatest extent possible.

- H. Install perimeter joint sealants as specified in Division 7 Section "Joint Sealants" and to produce weathertight installation.

- I. Erection Tolerances: Install aluminum-framed systems to comply with the following maximum tolerances:

1. Location and Plane: Limit variation from true location and plane to 1/8 inch in 12 feet; 1/4 inch over total length.
2. Alignment:
 - a. Where surfaces abut in line, limit offset from true alignment to 1/16 inch.
 - b. Where surfaces meet at corners, limit offset from true alignment to 1/32 inch.
3. Diagonal Measurements: Limit difference between diagonal measurement to 1/8 inch.

3.03 FIELD QUALITY CONTROL

- A. Testing Agency: Owner will engage a qualified independent testing and inspecting agency to perform field tests and inspections and prepare test reports.
- B. Repair or remove work where test results and inspections indicate that it does not comply with specified requirements.
- C. Additional testing and inspecting, at Contractor's expense, will be performed to determine compliance of replaced or additional work with specified requirements.

3.04 ADJUSTING

- A. Entrances: Adjust operating hardware for smooth operation according to hardware manufacturers' written instructions.
 - 1. Adjust closers to provide a 3-second closer sweep period for doors to move from a 70-degree open position to 3 inches from the latch measured to the leading door edge.

END OF SECTION

SECTION 08710 – DOOR HARDWARE

*This section revised and reissued with Addendum 1. Hardware sets #01 and #02 revised.
This section revised and reissued with Addendum 6. Hardware sets #02 and #104 revised.*

PART 1 - GENERAL

1.01 RELATED DOCUMENTS

- A. Drawings and general provisions of the Contract, including General and Supplementary Conditions and Division 1 Specification Sections, apply to this Section.

1.02 SUMMARY:

- A. Section Includes: Finish Hardware for door openings, except as otherwise specified herein.
 - 1. Door hardware for steel (hollow metal) doors.
 - 2. Door hardware for aluminum doors.
 - 3. Door hardware for wood doors.
 - 4. Door hardware for other doors indicated.
 - 5. Keyed cylinders as indicated.
- B. Intent of Hardware Groups
 - 1. Should items of hardware not definitely specified be required for completion of the Work, furnish such items of type and quality comparable to adjacent hardware and appropriate for service required.
 - 2. Where items of hardware aren't definitely or correctly specified, are required for completion of the Work, a written statement of such omission, error, or other discrepancy to Architect, prior to date specified for receipt of bids for clarification by addendum; or, furnish such items in the type and quality established by this specification, and appropriate to the service intended.

1.03 SUBSTITUTIONS

- A. Comply with Division 1.

1.04 SUBMITTALS

- A. Comply with Division 1.
- B. Special Submittal Requirements: Combine submittals of this Section with Sections listed below to ensure the "design intent" of the system/assembly is understood and can be reviewed together.
- C. Product Data: Manufacturer's specifications and technical data including the following:
 - 1. Detailed specification of construction and fabrication.
 - 2. Manufacturer's installation instructions.
 - 3. Wiring diagrams for each electric product specified. Coordinate voltage with electrical before submitting.
 - 4. Submit 6 copies of catalog cuts with hardware schedule.
- D. Shop Drawings - Hardware Schedule: Submit 6 complete reproducible copy of detailed hardware schedule in a vertical format.

1. List groups and suffixes in proper sequence.
 2. Completely describe door and list architectural door number.
 3. Manufacturer, product name, and catalog number.
 4. Function, type, and style.
 5. Size and finish of each item.
 6. Mounting heights.
 7. Explanation of abbreviations and symbols used within schedule.
 8. Detailed wiring diagrams, specially developed for each opening, indicating all electric hardware, security equipment and access control equipment, and door and frame rough-ins required for specific opening.
- E. Templates: Submit templates and "reviewed Hardware Schedule" to door and frame supplier and others as applicable to enable proper and accurate sizing and locations of cutouts and reinforcing.
1. Templates, wiring diagrams and "reviewed Hardware Schedule" of electrical terms to electrical for coordination and verification of voltages and locations.
- F. Samples: (If requested by the Architect)
1. 1 sample of Lever and Rose/Escutcheon design, (pair).
 2. 3 samples of metal finishes
- G. Contract Closeout Submittals: Comply with Division 1 including specific requirements indicated.
1. Operating and maintenance manuals: Submit 3 sets containing the following.
 - a. Complete information in care, maintenance, and adjustment, and data on repair and replacement parts, and information on preservation of finishes.
 - b. Catalog pages for each product.
 - c. Name, address, and phone number of local representative for each manufacturer.
 - d. Parts list for each product.
 2. Copy of final hardware schedule, edited to reflect, "As installed".
 3. Copy of final keying schedule
 4. As installed "Wiring Diagrams" for each piece of hardware connected to power, both low voltage and 110 volts.
 5. One set of special tools required for maintenance and adjustment of hardware, including changing of cylinders.

1.05 QUALITY ASSURANCE

- A. Comply with Division 1.
1. Exterior Openings Severe Windstorm Components testing: Listed and labeled by a testing and inspecting agency acceptable to authority having jurisdiction, based on testing according to ANSI A250.13. Further compliance with Florida Building Codes for Hurricane (NOA) for Exterior Openings.
 2. Statement of qualification for distributor and installers.
 3. Statement of compliance with regulatory requirements and single source responsibility.

4. Distributor's Qualifications: Firm with 3 years experience in the distribution of commercial hardware.
 - a. Distributor to employ full time Architectural Hardware Consultants (AHC) for the purpose of scheduling and coordinating hardware and establishing keying schedule.
 - b. Hardware Schedule shall be prepared and signed by an AHC.
 5. Installer's Qualifications: Firm with 3 years experienced in installation of similar hardware to that required for this Project, including specific requirements indicated.
 6. Regulatory Label Requirements: Provide testing agency label or stamp on hardware for labeled openings.
 - a. Provide UL listed hardware for labeled and 20 minute openings in conformance with requirements for class of opening scheduled.
 - b. Underwriters Laboratories requirements have precedence over this specification where conflict exists.
 7. Single Source Responsibility: Except where specified in hardware schedule, furnish products of only one manufacturer for each type of hardware.
- B. Review Project for extent of finish hardware required to complete the Work. Where there is a conflict between these Specifications and the existing hardware, notify the Architect in writing and furnish hardware in compliance with the Specification unless otherwise directed in writing by the Architect.

1.06 DELIVERY, STORAGE, AND HANDLING

- A. Packing and Shipping: Comply with Division 1.
1. Deliver products in original unopened packaging with legible manufacturer's identification.
 2. Package hardware to prevent damage during transit and storage.
 3. Mark hardware to correspond with "reviewed hardware schedule".
 4. Deliver hardware to door and frame manufacturer upon request.
- B. Storage and Protection: Comply with manufacturer's recommendations.

1.07 PROJECT CONDITIONS:

- A. Coordinate hardware with other work. Furnish hardware items of proper design for use on doors and frames of the thickness, profile, swing, security and similar requirements indicated, as necessary for the proper installation and function, regardless of omissions or conflicts in the information on the Contract Documents.
- B. Review Shop Drawings for doors and entrances to confirm that adequate provisions will be made for the proper installation of hardware.

1.08 WARRANTY:

- A. Refer to Conditions of the Contract
- B. Manufacturer's Warranty:
1. Closers: Ten years
 2. Exit Devices: Three Years
 3. Locksets & Cylinders: Three years
 4. All other Hardware: Two years.

1.09 OWNER'S INSTRUCTION:

A. Instruct Owner's personnel in operation and maintenance of hardware units.

1.10 MAINTENANCE:

- A. Extra Service Materials: Deliver to Owner extra materials from same production run as products installed. Package products with protective covering and identify with descriptive labels. Comply with Division 1 Closeout Submittals Section.
 - 1. Special Tools: Provide special wrenches and tools applicable to each different or special hardware component.
 - 2. Maintenance Tools: Provide maintenance tools and accessories supplied by hardware component manufacturer.
 - 3. Delivery, Storage and Protection: Comply with Owner's requirements for delivery, storage and protection of extra service materials.
- B. Maintenance Service: Submit for Owner's consideration maintenance service agreement for electronic products installed.

PART 2 - PRODUCTS

2.01 MANUFACTURERS:

A. The following manufacturers are approved subject to compliance with requirements of the Contract Documents. Approval of manufacturers other than those listed shall be in accordance with Division 1.

<u>Item:</u>	<u>Manufacturer:</u>	<u>Approved:</u>
Hinges	Stanley	Bommer, Hager
Continuous Hinges	Stanley	Select, Pemko
Locksets and Cylinders	Best	No Substitution
Exit Devices	Precision	No Substitution
Closers	Stanley	No Substitution
Push/Pull Plates	Trimco	Hager, Rockwood
Push/Pull Bars	Trimco	Hager, Rockwood
Protection Plates	Trimco	Hager, Rockwood
Overhead Stops	ABH	Rixson
Door Stops	Trimco	Hager, Rockwood
Flush Bolts	Trimco	Hager Rockwood
Threshold & Gasketing	National Guard	Hager, Pemko

2.02 MATERIALS:

- A. Hinges:
 - 1. Template screw hole locations
 - 2. Minimum of 2 permanently lubricated non-detachable bearings
 - 3. Equip with easily seated, non-rising pins
 - 4. Sufficient size to allow 180-degree swing of door
 - 5. Furnish hinges with five knuckles and flush concealed bearings
 - 6. Provide hinge type as listed in schedule.
 - 7. Furnish 3 hinges per leaf to 7 foot 6 inch height. Add one for each additional 30 inches in height or fraction thereof.

8. Tested and approved by BHMA for all applicable ANSI Standards for type, size, function and finish
 9. UL10C listed for Fire
- B. Geared Continuous Hinges:
1. Tested and approved by BHMA for ANSI A156.26-1996 Grade 1
 2. Anti-spinning through fastener
 3. UL10C listed for 3 hour Fire rating
 4. Non-handed
 5. Lifetime warranty
 6. Provide Fire Pins for 3-hour fire ratings
 7. Sufficient size to permit door to swing 180 degrees
- C. Mortise Type Locks and Latches:
1. Tested and approved by BHMA for ANSI A156.13, Series 1000, Operational Grade 1, Extra-Heavy Duty, Security Grade 2 and be UL10C
 2. Fit ANSI A115.1 door preparation
 3. Functions and design as indicated in the hardware groups
 4. Solid, one-piece, 3/4-inch (19mm) throw, anti-friction latchbolt made of self-lubricating stainless steel
 5. Deadbolt functions shall have 1 inch (25mm) throw bolt made of hardened stainless steel
 6. Latchbolt and Deadbolt are to extend into the case a minimum of 3/8 inch (9.5mm) when fully extended
 7. Auxiliary deadlatch to be made of one piece stainless steel, permanently lubricated
 8. Provide sufficient curved strike lip to protect door trim
 9. Lever handles must be of forged or cast brass, bronze or stainless steel construction and conform to ANSI A117.1. Levers that contain a hollow cavity are not acceptable
 10. Lock shall have self-aligning, thru-bolted trim
 11. Levers to operate a roller bearing spindle hub mechanism
 12. Mortise cylinders of lock shall have a concealed internal setscrew for securing the cylinder to the lockset. The internal setscrew will be accessible only by removing the core, with the control key, from the cylinder body.
 13. Spindle to be designed to prevent forced entry from attacking of lever
 14. Provide locksets with 7-pin removable and interchangeable core cylinders
 15. Each lever to have independent spring mechanism controlling it
 16. Core face must be the same finish as the lockset
- D. Exit Devices shall:
1. Tested and approved by BHMA for ANSI 156.3, Grade 1
 2. Provide a deadlocking latchbolt
 3. Non-fire rated exit devices shall have cylinder dogging.
 4. Touchpad shall be "T" style
 5. Exposed components shall be of architectural metals and finishes.

6. Lever design shall match lockset lever design
 7. Provide strikes as required by application.
 8. Fire exit devices to be listed for UL10C
 9. UL listed for Accident Hazard
 10. Provide vandal resistant or breakaway trim
 11. Aluminum vertical rod assemblies are acceptable only when provide with the manufacturers optional top and bottom stainless steel rod guard protectors
- E. Cylinders:
1. Provide the necessary cylinder housings, collars, rings & springs as recommended by the manufacturer for proper installation.
 2. Provide the proper cylinder cams or tail piece as required to operate all locksets and other keyed hardware items listed in the hardware sets.
 3. Coordinate and provide as required for related sections.
- F. Door Closers shall:
1. Tested and approved by BHMA for ANSI 156.4, Grade 1
 2. UL10C certified
 3. Closer shall have extra-duty arms and knuckles
 4. Conform to ANSI 117.1
 5. Maximum 2 7/16 inch case projection with non-ferrous cover
 6. Separate adjusting valves for closing and latching speed, and backcheck
 7. Provide adapter plates, shim spacers and blade stop spacers as required by frame and door conditions
 8. Full rack and pinion type closer with 1½" minimum bore
 9. Mount closers on non-public side of door, unless otherwise noted in specification
 10. Closers shall be non-handed, non-sized and multi-sized.
- G. Door Stops: Provide a dome floor or wall stop for every opening as listed in the hardware sets.
1. Wall stop and floor stop shall be wrought bronze, brass or stainless steel.
 2. Provide fastener suitable for wall construction.
 3. Coordinate reinforcement of walls where wall stop is specified.
 4. Provide dome stops where wall stops are not practical. Provide spacers or carpet riser for floor conditions encountered
- H. Over Head Stops: Provide a Surface mounted or concealed overhead when a floor or wall stop cannot be used or when listed in the hardware set.
1. Concealed overhead stops shall be heavy duty bronze or stainless steel.
 2. Surface overhead stops shall be heavy duty bronze or stainless steel.
- I. Push Plates: Provide with four beveled edges ANSI J301, .050 thickness, size as indicated in hardware set. Furnish oval-head countersunk screws to match finish.
- J. Pulls with plates: Provide with four beveled edges ANSI J301, .050 thickness Plate s with ANSI J401 Pull as listed in hardware set. Provide proper fasteners for door construction.

- K. Push Pull Bars: Provide ANSI J504, .1" Dia. Pull and push bar model and series as listed in hardware set. Provide proper fasteners for door construction.
- L. Kickplates: Provide with four beveled edges ANSI J102, 10 inches high by width less 2 inches on single doors and 1 inch on pairs of doors. Furnish oval-head countersunk screws to match finish.
- M. Mop plates: Provide with four beveled edges ANSI J103, 4 inches high by width less 1 inch on single doors and 1 inch on pairs of doors. Furnish oval-head countersunk screws to match finish.
- N. Armor Plates: Provide ANSI J101 with four beveled edges, 34 inches high by width less 1 inch on single or pairs of doors. Furnish oval-head countersunk screws to match finish.
- O. Provide cutouts for hardware as listed in the hardware sets.
 - 1. Provide Warnock Hersey labeled plates for 3 hour metal fire doors where allowed by local authority.
- P. Door Bolts: Flush bolts for wood or metal doors.
- Q. Provide a set of Automatic bolts ANSI/BHMA 156.3 Type 25 for hollow metal label doors.
 - 1. Provide a set of Automatic bolts ANSI/BHMA 156.3 Type 27 at wood label doors.
 - 2. Manual flush bolts ANSI/BHMA 156.16 at openings where allowed local authority.
 - 3. Provide Dust Proof Strike ANSI/BHMA 156.16 at doors with flush bolts without thresholds.
- R. Coordinator and Brackets: Provide a surface mounted coordinator when automatic bolts are used in the hardware set.
- S. Coordinator shall comply with ANSI/BHMA A1156.3 Type 21A full width of the opening.
 - 1. Provide mounting brackets for soffit applied hardware.
 - 2. Provide hardware preparation (cutouts) for latches as necessary.
- T. Quick Connect Power Transfer: Power transfer device shall be a steel housing and flexible tube. Secure and inconspicuous channel is to bring power from the frame to the door.
 - 1. Precision EPT-12C
 - 2. Tube shall contain 12 Wire bundle with Stanley Quick Connect Connectors one 4 wire connector consisting of two 18AWG wires and 2 24AWG wires and one 8 wire connector with 8 24AWG wires.
- U. Quick Connect plug-in connectors: Stanley quick connect plug-in must be used with a combination of the following components to work as a complete plug and play system.
 - 1. Best locks series 45HW, 45HM, 8KW, 9KW, 9KM
 - 2. To include Quick connectors to Best lock products Suffix "C" Example (45HW-7DEL14H DS **C**)
 - 3. Precision Exit Devices 2000 Series, DE, DS, TS, TDS, LDS, ELR
 - 4. To include Quick connectors to Precision Electric Exit device products Prefix "C" Example (**C** ELR 2108 x V4908A TS)
 - 5. Precision 12 Conductor Electric Power Transfer EPT-12C
 - 6. Stanley 12 Hinges Conductor Hinge CECB179-12C

- V. Quick Connect Wire Harnesses: The Quick Connect wire harness shall have of one four wire connector and one eight wire connector. The four wire connector has two 18AWG and two 24AWG wires. The eight wire connector has eight 24AWG wires Stanley quick connect wire harnesses are available in various length's, 3" (76mm), 6" (152mm), 12" (304mm), 26" (660mm) 32" (812mm) 38" (965mm), 44" (1117mm), 50" (1270mm) and 192" (4876mm).
1. Wire Harness that is terminated at both ends is specified as WH-size (Example WH-3).
 2. Wire Harness that is terminated at one end with exposed pin head at the other is specified as WH-size P (Example WH-3P).
 3. Wire Harness 6" (152mm) terminated at one end with bray leads on the other is specified as WH-6E.
 4. Notes: The Wire harnesses with suffix "E" has brae wire ends, is used to connect the quick connect harness to a hardwired connection. Wire harnesses of different lengths may be combined to form a desired length
- W. The maximum size hole needed to pass through the quick connect plug is 1" (25MM).
- X. Power Supply: Provide power supply for (ELR) Electric Latch Retraction exit devices
1. Motherboard will accept up to four plug-in Control Modules. Provide the appropriate necessary control module to operate the number of ELR exit devices used at each opening. The Control Module shall include a Time delay Feature, variable (0-4 minuets) latch retraction period in response to a momentary input.
 2. UL Listed for class II output
 3. Include circuit breakers for protection of motherboard
 4. 115 or 230 Volt user selectable switch, with AC input= 115 Volt at 1 Amp
 5. Control module shall include Fire alarm terminal and Auxiliary contacts for remote signaling.
 6. Optional card for Battery Backup (BT) power tap module to operate a Card reader by Security provider or when ELR devices require battery backup (Lead Acid Batteries are not included and is to be furnished by others)
 7. Precision ELR150 Series with the required modules.
- Y. Power Transfer: Power transfer device shall be a steel housing and flexible tube. Secure and inconspicuous channel is to bring power from the frame to the door.
1. Precision EPT-12C
 2. Tube shall accept up to 5/16" wire bundle and accommodate a door swing of 120 Deg.
 3. Wires as required by others
- Z. Seals: All seals shall be finished to match adjacent frame color. Seals shall be furnished as listed in schedule. Material shall be UL listed for labeled openings.
- AA. Weatherstripping: Provide at head and jambs only those units where resilient or flexible seal strip is easily replaceable. Where bar-type weatherstrip is used with parallel arm mounted closers install weatherstrip first.
1. Weatherstrip shall be resilient seal of (Neoprene, Polyurethane, Vinyl, Pile, Nylon Brush, Silicone)
 2. UL10C Positive Pressure rated seal set when required.

- BB. Door Bottoms/Sweeps: Surface mounted or concealed door bottom where listed in the hardware sets.
1. Door seal shall be resilient seal of (Neoprene, Polyurethane, Nylon Brush, Silicone)
 2. UL10C Positive Pressure rated seal set when required.
- CC. Thresholds: Thresholds shall be aluminum beveled type with maximum height of ½" for conformance with ADA requirements. Furnish as specified and per details. Provide fasteners and screws suitable for floor conditions.
- DD. Key Control: Provide one wall mounted key cabinet complete with hooks, index and tags with hook quantity 50% over lock quantity.
- EE. Key Control Software: Provide one, Keystone® 600N key management control software. S hall include general features
1. Password restricted logins.
 2. List all keys and items currently due back (or due back by any day designated)
 3. Lists all cores and their location, building and doors, and cross-references people to cores, doors, building they access.
 4. Comprehensive list of reports available as an on-screen menu.
 5. Built-in easy to use backup program.
 6. Program always displays date of last backup.
 7. Dynamic searching capabilities for all records.
 8. On-screen indicator shows when historical info. Is present for a record.
 9. On-screen indicator appears when notes are present on a record.
 10. Able to operate in an NTFS network environment with TCPIP protocol
 11. Multiple users can access program at the same time.
 12. Software shall include a "Best" Automated Pin Segment Calculator and a Manual Pin Segment Calculator for authorized "Best" building lock shop facilities.
 13. Software program is to be compatible with Windows NT, 2000 or XP with TCPIP protocol.
- FF. Silencers: Furnish silencers on all interior frames, 3 for single doors, 2 for pairs. Omit where any type of seals occur.

2.03 FINISH:

- A. Designations used in Schedule of Finish Hardware - 3.5, and elsewhere to indicate hardware finishes are those listed in ANSI/BHMA A156.18 including coordination with traditional U.S. finishes shown by certain manufacturers for their products
- B. Powder coat door closers to match other hardware, unless otherwise noted.
- C. Aluminum items shall be finished to match predominant adjacent material. Seals to coordinate with frame color.

2.04 KEYS AND KEYING:

- A. Provide keyed brass construction cores and keys during the construction period. Construction control and operating keys and core shall not be part of the Owner's permanent keying system or furnished in the same keyway (or key section) as the Owner's permanent keying system. Permanent cores and keys (prepared according to the accepted keying schedule) will be furnished to the Owner.

- B. Cylinders, removable and interchangeable core system: Best Standard 7-pin.
- C. Permanent keys and cores: Stamped with the applicable key mark for identification. These visual key control marks or codes will not include the actual key cuts. Permanent keys will also be stamped "Do Not Duplicate."
- D. Transmit Grand Masterkeys, Masterkeys and other Security keys to Owner by Registered Mail, return receipt requested.
- E. Furnish keys in the following quantities:
 - 1. 3 each Grand Masterkeys
 - 2. 6 each Masterkeys
 - 3. 2 each Control keys
 - 4. 3 each Change keys each keyed core
 - 5. 15 each Construction masterkeys
 - 6. 2 each Construction Control keys
- F. The Owner, or the Owner's agent, will install permanent cores and return the construction cores to the Hardware Supplier. Construction cores and keys remain the property of the Hardware Supplier.
- G. Keying Schedule: Arrange for a keying meeting, and programming meeting with Architect Owner and hardware supplier, and other involved parties to ensure locksets and locking hardware, are functionally correct and keying and programming complies with project requirements. Furnish 3 typed copies of keying and programming schedule to Architect.

PART 3 - EXECUTION

3.01 EXAMINATION

- A. Verification of conditions: Examine doors, frames, related items and conditions under which Work is to be performed and identify conditions detrimental to proper and or timely completion.
 - 1. Do not proceed until unsatisfactory conditions have been corrected.

3.02 HARDWARE LOCATIONS:

- A. Mount hardware units at heights indicated in the following publications except as specifically indicated or required to comply with the governing regulations.
 - 1. Recommended Locations for Builder's Hardware for Standard Steel Doors and Frames, by the Door and Hardware Institute (DHI).
 - 2. Recommended locations for Architectural Hardware for flush wood doors (DHI).
 - 3. WDMA Industry Standard I.S.-1A-04, Industry Standard for Architectural wood flush doors.

3.03 INSTALLATION:

- A. Install each hardware item per manufacturer's instructions and recommendations. Do not install surface mounted items until finishes have been completed on the substrate. Set units level, plumb and true to line and location. Adjust and reinforce the attachment substrate as necessary for proper installation and operation.
- B. Conform to local governing agency security ordinance.
- C. Install Conforming to ICC/ANSI A117.1 Accessible and Usable Building and Facilities.

- D. Installed hardware using the manufacturers fasteners provided. Drill and tap all screw holes located in metallic materials. Do not use “Riv-Nuts” or similar products.

3.04 FIELD QUALITY CONTROL AND FINAL ADJUSTMENT

- A. Contractor/Installers, Field Services: After installation is complete, contractor shall inspect the completed door openings on site to verify installation of hardware is complete and properly adjusted, in accordance with both the Contract Documents and final shop drawings.
 - 1. Check and adjust closers to ensure proper operation.
 - 2. Check latchset, lockset, and exit devices are properly installed and adjusted to ensure proper operation.
 - a. Verify levers are free from binding.
 - b. Ensure latchbolts and dead bolts are engaged into strike and hardware is functioning.
 - 3. Report findings, in writing, to architect indicating that all hardware is installed and functioning properly. Include recommendations outlining corrective actions for improperly functioning hardware is required.

3.05 SCHEDULE OF FINISH HARDWARE:

Manufacturer List

<u>Code</u>	<u>Name</u>
AB	ABH Manufacturing Inc.
BE	Best Access Systems
BY	By Other related Trades-Contractor to coordinate
NG	National Guard
PR	Precision
ST	Stanley
TR	Trimco

Option List

<u>Code</u>	<u>Description</u>
B4E	Bevel 4 edges
CD	CYLINDER DOGGING
C	Quick connect wires
CE	CONC. WIRES
DE	DELAYED EGRESS
DS	DOOR POSITION SWITCH
HC	Hurricane Code Device
M1	BRONZE CHAIN
SN	Sex Nuts (Pkg. of 4)
TS	TOUCHBAR MONITORING SWITCH (RQE)
WC	PADLOCK WEATHER COVERS
B4E	BEVELED 4 EDGES
ELR	ELECTRIC LATCH RETRACTION
RQE	Request To Exit concealed switch
SNB (6)	SEX NUTS & BOLTS (6)
SN	Sex Nuts and Bolts
EPT Prep	EPT Prep (full mortise)
CSK	COUNTER SINKING

Finish List

<u>Code</u>	<u>Description</u>
628	Aluminum
626	Satin Chromium Plated
628	Satin Aluminum, Clear Anodized
630	Satin Stainless Steel
689	Aluminum Painted
600	Spray Primed
GRE	Grey
630	Stainless Steel, Dull

EXTERIOR HARDWARE SETS

Hardware Set #01 revised with Addendum 1. Card reader and related components deleted.

SET #01 - Entry Alum Pair

2	Continuous Hinges	661HD	Alum	ST
1	Key Removable mullion	HCKR822	689	PR
1	Elect. Exit Device – RHR leaf	HC 2103 CD x C03	630	PR
1	Exit Device – LHR leaf	HC 2101 CD	630	PR
1	Rim Cylinder	1E-72 PATD	626	BE
2	Mortise Cylinder	1E-74 PATD	626	BE
2	Offset Pulls	1171-24" x TYPE C MTG.	630	TR
2	Closers w/ HO Stop	D4550 HCS x SN x P45HD-110 x P45HD-112	689	ST
2	Drop Plate mounted on Door	P45-180	689	ST
2	Ext Floor stops	1209		TR
1	Threshold	896		NA
2	Door Bottoms	By Alum Door Supplier		BY
1	Set Seal including Center	By Alum. Door Supplier		BY
1	Conc Door Position Switch	By Security Supplier		BY

Hardware Set #02 revised with Addendum 1. Exit Device for LHR leaf revised.

Hardware Set #02 revised with Addendum 5. Door changed to FRP.

SET #02 - Entry FRP Pair

2	Continuous Hinges	661HD	Alum	ST
1	Exit Device – RHR leaf	HC 2103 CD x C03	630	PR
1	Exit Device – LHR leaf	HC 2101 CD	630	PR
1	Rim Cylinder	1E-72 PATD	626	BE
2	Mortise Cylinder	1E-74 PATD	626	BE
2	Offset Pulls	1171-24" x TYPE C MTG.	630	TR
2	Closers w/ HO Stop	D4550 HCS x SN x P45HD-110 x P45HD-112	689	ST
2	Drop Plate mounted on Door	P45-180	689	ST
2	Ext Floor stops	1209		TR
1	Threshold	896		NA
2	Door Bottoms	By Alum Door Supplier		BY
1	Set Seal including Center	By Alum. Door Supplier		BY

SET #03 – Kitchen Exit HM 4'-0" wide Door

1	Continuous Hinges	661HD	Alum	ST
1	Exit Device	HC 2108 CD x V4908D x SNB	630	PR
1	Rim Cylinder	1E-72 PATD	626	BE
1	Mortise Cylinder	1E-74 PATD	626	BE
1	Closer w/ HO stop	D4550 HCS X TB	AL	ST
1	Kick Plate	K1050 10" x 2" LDW CSK B4E	630	RO
2	Ext Floor stops	1209		TR
1	Threshold	896		NG
1	Weatherstrip SET	700SA (Head & jambs)		NG
1	Door Sweep/rain drip	95WH		NG
1	Rain Drip	16A x 4" over Dr. Width		NG

SET #04 – Assembly Exit door

1	Continuous Hinges	661HD	Alum	ST
1	Exit Device	HC 2103 CD x V4903D x SNB	630	PR
1	Rim Cylinder	1E-72 PATD	626	BE
1	Mortise Cylinder	1E-74 PATD	626	BE
1	Closer w/ HO stop	D4550 HCS X TB	AL	ST
2	Ext Floor stops	1209		TR
1	Threshold	896		NG
1	Weatherstrip SET	700SA (Head & jambs)		NG
1	Door Sweep/rain drip	95WH		NG
1	Rain Drip	16A x 4" over Dr. Width		NG

SET #05 – Mechanical Equipment Room PAIR

2	Continuous Hinges	661HD	Alum	ST
1	Flush Bolt SET-LHR leaf	3915 x 3915	626	TR
1	Dust Proof Strike	3911	630	TR
1	Exit Device	HC 2103 CD x V4903D x SNB	630	PR
1	Rim Cylinder	1E-72 PATD	626	BE
1	Mortise Cylinder	1E-74 PATD	626	BE
1	Closer w/ HO stop	D4550 HCS X TB	AL	ST
2	Ext Floor stops	1209		TR
1	Threshold	896		NG
1	Weatherstrip SET	700SA (Head & jambs)		NG
1	Door Sweep/rain drip	95WH		NG
1	Rain Drip	16A x 4" over Dr. Width		NG

SET #06 – Exterior Single Restroom Single Door

1	Continuous Hinges	661HD	Alum	ST
1	Lock w/ Privacy	45H-7TD14N VIN VIT PATD	630	BE
1	Closer	D4550 REG/PA X TB	AL	ST
1	Mop Plate	KOO50 -6" X 1" LDW CSK B4E	630	TR
1	Floor Stop	1211	626	TR
1	Threshold	896		NG
1	Weatherstrip SET	700SA (Head & jambs)		NG
1	Door Sweep/rain drip	95WH		NG
1	Rain Drip	16A x 4" over Dr. Width		NG

INTERIOR HARDWARE SETS

SET #100 – Office Lock - 20Min UL

3	Hinges	CB191 4 1/2 x 4 1/2	630	ST
1	Office Lock	93K-7AB14C PATD	630	BE
1	Closer	D4551 Reg/PA x SN	689	ST
1	Floor Stop	1211	626	TR
1	Cold Smoke Seal set	5020CL	Clear	NG
1	Intumescent Hot Smoke Seal	Provided by door supplier in the door		BY

SET #101 – Storeroom Lock- 20Min UL

3	Hinges	CB191 4 1/2 x 4 1/2	630	ST
1	Storeroom Lock	93K-7D14C PATD	630	BE
1	Closer	D4550 Reg/PA X TB	AL	ST
1	Floor Stop	1211	626	TR
1	Cold Smoke Seal set	5020CL	Clear	NG
1	Intumescent Hot Smoke Seal	Provided by door supplier in the door		BY

SET #102 Entry/EXIT Pair 20Min UL

2	Continuous Hinges	661HD	Alum	ST
1	Key Removable mullion	KR822	689	PR
1	Exit Device – RHR leaf	2108 CD x V4908D	630	PR
1	Exit Device – LHR leaf	2102 CD x 4902D	630	PR
1	Rim Cylinder	1E-72 PATD	626	BE
2	Mortise Cylinder (CD)	1E-74 PATD	626	BE
2	Closers w/ Stop	D4550 CS x SN	689	ST
1	Cold Smoke Seal set	5020CL	Clear	NG
1	Intumescent Hot Smoke Seal	Provided by door supplier in the door		BY
1	Mullion Seal	5100S		NG
1	Meeting style Astragal Seal	SET 115NA		NG

SET #103 – Toilet w/ Passage Set - 20 Min UL

3	Hinges	CB191 4 1/2 x 4 1/2	630	ST
1	Passage Set	93K-0N14C	630	BE
1	Closer	D4551 Reg/PA X TB	689	ST
1	Floor Stop	1211	626	TR
1	Cold Smoke Seal set	5020CL	Clear	NG
1	Intumescent Hot Smoke Seal	Provided by door supplier in the door		BY

Hardware Set #104 revised with Addendum 5. Storeroom lock revised.

SET #104 – Storeroom Lock- 20 Min UL

3	Hinges	CB191 4 1/2 x 4 1/2	630	ST
1	Storeroom Lock	9K3-7D14C PATD	630	BE
1	Closer	D4550 Reg/PA X TB	AL	ST
1	Floor Stop	1211	626	TR
1	Cold Smoke Seal set	5020CL	Clear	NG
1	Intumescent Hot Smoke Seal	Provided by door supplier in the door		BY

SET #105 – Office Lock - Not Rated

3	Hinges	CB191 4 1/2 x 4 1/2	630	ST
1	Office/Deadbolt Lock	93K-7AB14C PATD	630	BE
1	Floor Stop	1211	626	TR
3	Door Silencers	1229A	GREY	TR

SET #106 – Storeroom Lock- Not Rated

3	Hinges CB191 4 1/2 x 4 1/2	630		ST
1	Storeroom Lock	93K-7D14C PATD	630	BE
1	Floor Stop	1211	626	TR
3	Door Silencers	1229A		GREY TR

SET #107 – Storeroom Lock- Dry Storage - Not Rated

3	Hinges CB191 4 1/2 x 4 1/2	630		ST
1	Storeroom Lock	93K-7D14C PATD	630	BE
1	Kick Plate	KOO50 -10" X 2" LDW CSK B4E	630	TR
1	Floor Stop	1211	626	TR
1	Cold Smoke Seal set	5020CL		Clear NG
1	Auto Door Bottom	229SSS	630	NG

SET #108 – Kitchen-Office Lock w/ DB - Not Rated

3	Hinges CB191 4 1/2 x 4 1/2	630		ST
1	Office/Deadbolt Lock	93K-7AB14C PATD	630	BE
1	Kick Plate	KOO50 -10" X 2" LDW CSK B4E	630	TR
1	Floor Stop	1211	626	TR
1	Cold Smoke Seal set	5020CL		Clear NG
1	Auto Door Bottom	229SSS	630	NG

SET #109 – Storeroom Lock- Furniture Storage

3	Hinges CB191 4 1/2 x 4 1/2	630		ST
1	Flush Bolt SET-LHR leaf	3915 x 3915	626	TR
1	Dust Proof Strike	3911	630	TR
1	Storeroom Lockw/DB	93K-7TD14C PATD	630	BE
1	Closer w/ HO stop	D4550 HCS X TB	689	ST
2	Kick Plate	KOO50 -10" X 2" LDW CSK B4E	630	TR
1	Seal set-dirt	5020CL		Clear NG
2	Auto Door Bottom	229SSS	630	NG
1	Overlapping Astragal-RHR	158SA mount on Outside Active leaf		AL NG

END OF SECTION

SECTION 08800 - GLAZING

PART 1 - GENERAL

1.01 RELATED DOCUMENTS

- A. Drawings and general provisions of the Contract, including General and Supplementary Conditions and Division 1 Specification Sections, apply to this Section.

1.02 SUMMARY

- A. Section includes glazing for the following products and applications, including those specified in other Sections where glazing requirements are specified by reference to this Section:
 - 1. Storefront framing.
 - 2. Glazed entrances.
 - 3. Doors.
- B. Related Sections include:
 - 1. Division 8 Section "Aluminum-Framed Entrances and Storefront."

1.03 DEFINITIONS

- A. Manufacturers of Glass Products: Firms that produce primary glass, fabricated glass, or both, as defined in referenced glazing publications.
- B. Glass Thicknesses: Indicated by thickness designations in nominal inches according to ASTM C 1036.
- C. Interspace: Space between lites of an insulating-glass unit that contains dehydrated air or a specified gas.
- D. Deterioration of Coated Glass: Defects developed from normal use that are attributed to the manufacturing process and not to causes other than glass breakage and practices for maintaining and cleaning coated glass contrary to manufacturer's written instructions. Defects include peeling, cracking, and other indications of deterioration in metallic coating.
- E. Deterioration of Insulating Glass: Failure of hermetic seal under normal use that is attributed to the manufacturing process and not to causes other than glass breakage and practices for maintaining and cleaning insulating glass contrary to manufacturer's written instructions. Evidence of failure is the obstruction of vision by dust, moisture, or film on interior surfaces of glass.
- F. Deterioration of Laminated Glass: Defects developed from normal use that are attributed to the manufacturing process and not to causes other than glass breakage and practices for maintaining and cleaning laminated glass contrary to manufacturer's written instructions. Defects include edge separation, delamination materially obstructing vision through glass, and blemishes exceeding those allowed by referenced laminated-glass standard.

1.04 PERFORMANCE REQUIREMENTS

- A. Provide glazing systems capable of withstanding normal thermal movement and wind and impact loads (where applicable) without failure, including loss or glass breakage

attributable to the following: defective manufacture, fabrication, and installation; failure of sealants or gaskets to remain watertight and airtight; deterioration of glazing materials; or other defects in construction.

- B. Glass thickness designations indicated are minimums and are for detailing only. Confirm glass thicknesses by analyzing Project loads and in-service conditions. Provide glass lites in the thickness designations indicated for various size openings, but not less than thicknesses and in strengths (annealed or heat treated) required to meet or exceed the following criteria:
1. Glass Thicknesses: Select minimum glass thicknesses to comply with ASTM E 1300, according to the following requirements:
 - a. Specified Design Wind Loads: 45 psf (132 mph).
 - b. Maximum Lateral Deflection: For the following types of glass supported on all 4 edges, provide thickness required that limits center deflection at design wind pressure to 1/50 times the short side length or 1 inch, whichever is less.
 - (1) Monolithic-glass lites heat treated to resist wind loads.
 - (2) Insulating glass units.
 - (3) Laminated-glass lites.
- C. Provide glazing that allows for thermal movements resulting from the following maximum change (range) in ambient and surface temperatures acting on glass framing members and glazing components. Base engineering calculation on surface temperatures of materials due to both solar heat gain and nighttime-sky heat loss.
1. Temperature Change (Range): 120 deg F, ambient; 180 deg F, material surfaces.
- D. Provide glass with performance properties specified based on manufacturer's published test data, as determined according to procedures indicated below:
1. Monolithic-Glass Lites: Based on units with lites of thickness indicated.
 2. Laminated- Glass Lites: Based on products of construction indicated.
 3. Insulating- Glass Lites, Based on units of thickness indicated for overall unit and for each lite.
 4. Center-of-Glass Values: Based on using LBL-44789 WINDOW 5.0 computer program for the following methodologies:
 - a. U-Factors: NFRC 100 expressed as Btu/ sq. ft. x h x deg F.
 - b. Solar Heat Gain Coefficient: NFRC 200.
 - c. Solar Optical Properties: NFRC 300.

1.05 SUBMITTALS

- A. Submit manufacturer's acknowledgement letter. Follow Division 1 Section "Submittal Procedures."
- B. Submit product data for each glass product and glazing material indicated.
- C. Submit glazing schedule. Use same designations indicated on Drawings for glazed openings in preparing a schedule listing glass types and thicknesses for each size opening and location.
- D. Submit product certificates signed by manufacturers of glass and glazing products certifying that products furnished comply with requirements.

1. For solar-control low-e-coated glass, provide documentation demonstrating that manufacturer of coated glass is certified by coating manufacturer.
- E. Submit qualification data for installers.
- F. Submit special warranties specified in this Section.

1.06 QUALITY ASSURANCE

- A. Installer Qualifications: An experienced installer who has completed glazing similar in material, design, and extent to that indicated for this Project; whose work has resulted in glass installations with a record of successful in-service performance.
- B. Obtain the following through one source from a single manufacturer for each glass type: clear float glass, laminated glass, and insulating glass.
- C. Obtain glazing accessories through one source from a single manufacturer for each product and installation method indicated.
- D. Safety Glazing Products: Comply with testing requirements in 16 CFR 1201.
1. Subject to compliance with requirements, obtain safety glazing products permanently marked with certification label of the Safety Glazing Certification Council or another certification agency or manufacturer acceptable to authorities having jurisdiction.
 2. Where glazing units, including Kind FT glass and laminated glass, are specified in Part 2 articles for glazing lites more than 9 sq. ft. in area, provide glazing products that comply with Category II materials, and for lites 9 sq. ft. or less in area, provide glazing products that comply with Category I or II materials.
- E. Subject to compliance with requirements, obtain exterior glazing products with manufacturer's certification label affixed to the interior of the glazing acceptable to authorities having jurisdiction stating product's thermal and optical performance properties. Do not remove label until authorized to do so by authorities.
- F. Comply with published recommendations of glass product manufacturers and organizations below, unless more stringent requirements are indicated. Refer to these publications for glazing terms not otherwise defined in this Section or in referenced standards.
1. GANA Publications:
 - a. "Glazing Manual."
 - b. Laminated Division's "Laminated Glass Design Guide."
 2. IGMA Publication for Insulating Glass: SIGMA TM-3000, "Glazing Guidelines for Sealed Insulating Glass Units."

1.07 DELIVERY, STORAGE, AND HANDLING

- A. Protect glazing materials according to manufacturer's written instructions and as needed to prevent damage to glass and glazing materials from condensation, temperature changes, direct exposure to sun, or other causes.

1.08 PROJECT CONDITIONS

- A. Environmental Limitations: Do not proceed with glazing when ambient and substrate temperature conditions are outside limits permitted by glazing material manufacturers and when glazing channel substrates are wet from rain, frost, condensation, or other causes.

1.09 WARRANTY

- A. Manufacturer's Special Warranty on Laminated Glass:
 - 1. Manufacturer's standard form, made out to Owner and signed by laminated-glass manufacturer agreeing to replace laminated-glass units that deteriorate as defined in "Definitions" Article, f.o.b. the nearest shipping point to Project site, within specified warranty period indicated below.
 - 2. Warranty Period: Five years from date of Substantial Completion.
- B. Manufacturer's Special Warranty on Insulating Glass:
 - 1. Manufacturer's standard form, made out to Owner and signed by insulating-glass manufacturer agreeing to replace insulating-glass units that deteriorate as defined in "Definitions" Article, f.o.b. the nearest shipping point to Project site, within specified warranty period indicated below.
 - 2. Warranty Period: 10 years from date of Substantial Completion.

PART 2 - PRODUCTS

2.01 MANUFACTURERS

- A. In other Part 2 articles where titles below introduce lists, the following requirements apply to product selection:
 - 1. Basis-of-Design Product: The design for each glazing product is based on the product named. Subject to compliance with requirements, provide either the named product or a comparable product by one of the other manufacturers specified.

2.02 VISION GLASS PRODUCTS

- A. Annealed Float Glass: ASTM C 1036, Type I (transparent flat glass), Quality-Q3; of class indicated.
- B. Heat-Treated Float Glass: ASTM C 1048; Type I (transparent flat glass); Quality-Q3; of class, kind, and condition indicated.
 - 1. Fabrication Process: By horizontal (roller-hearth) process with roll-wave distortion parallel to bottom edge of glass as installed, unless otherwise indicated.
 - 2. For uncoated glass, comply with requirements for Condition A.
 - 3. For coated vision glass, comply with requirements for Condition C (other uncoated glass).
 - 4. Provide Kind FT (fully tempered) float glass in place of annealed or Kind HS (heat-strengthened) float glass where safety glass is indicated.
- C. Sputter-Coated Float Glass: ASTM C 1376, float glass with metallic-oxide or -nitride coating deposited by vacuum deposition process after manufacture and heat treatment (if any), and complying with other requirements specified.
- D. Laminated Glass: ASTM C 1172, and complying with other requirements specified and with the following:
 - 1. Interlayer: Polyvinyl butyral of thickness indicated with a proven record of no tendency to bubble, discolor, or lose physical and mechanical properties after laminating glass lites and installation.

2. Laminating Process: Laminate lites in autoclave with heat plus pressure. Fabricate laminated glass to produce glass free of foreign substances and air or glass pockets.
- E. Insulating-Glass Units, General: Factory-assembled units consisting of sealed lites of glass separated by a dehydrated interspace, and complying with ASTM E 774 for Class CBA units and with requirements specified in this Article and in Part 2 "Insulating-Glass Units" Article.
1. Overall Unit Thickness and Thickness of Each Lite: Dimensions indicated for insulating-glass units are nominal and the overall thicknesses of units are measured perpendicularly from outer surfaces of glass lites at unit's edge.
 2. Sealing System: Dual seal, with manufacturer's standard primary and secondary sealants.
 3. Spacer Specifications: Manufacturer's standard spacer material and construction.

2.03 GLAZING GASKETS

- A. Dense Compression Gaskets: Molded or extruded gaskets of material indicated below, complying with standards referenced with name of elastomer indicated below, and of profile and hardness required to maintain watertight seal:
1. EPDM, ASTM C 864.
 2. Silicone, ASTM C 1115.
 3. Thermoplastic polyolefin rubber, ASTM C 1115.
 4. Any material indicated above.
- B. Soft Compression Gaskets: Extruded or molded, closed-cell, integral-skinned gaskets of material indicated below; complying with ASTM C 509, Type II, black; and of profile and hardness required to maintain watertight seal:
1. EPDM.
 2. Silicone.
 3. Thermoplastic polyolefin rubber.
 4. Any material indicated above.

2.04 MISCELLANEOUS GLAZING MATERIALS

- A. Provide products of material, size, and shape complying with referenced glazing standard, requirements of manufacturers of glass and other glazing materials for application indicated, and with a proven record of compatibility with surfaces contacted in installation.
- B. Cleaners, Primers, and Sealers: Types recommended by sealant or gasket manufacturer.
- C. Setting Blocks: Elastomeric material with a Shore, Type A durometer hardness of 85, plus or minus 5.
- D. Spacers: Elastomeric blocks or continuous extrusions with a Shore, Type A durometer hardness required by glass manufacturer to maintain glass lites in place for installation indicated.
- E. Edge Blocks: Elastomeric material of hardness needed to limit glass lateral movement (side walking).

2.05 FABRICATION OF GLAZING UNITS

- A. Fabricate glazing units in sizes required to glaze openings indicated for Project, with edge and face clearances, edge and surface conditions, and bite complying with written instructions of product manufacturer and referenced glazing publications, to comply with system performance requirements.

2.06 MONOLITHIC FLOAT-GLASS UNITS

- A. Uncoated Clear Float-Glass Units:
 - 1. Class 1 (clear) annealed or Kind HS (heat-strengthened) float glass where heat strengthening is required to resist thermal stresses induced by differential shading of individual glass lites and to comply with system performance requirements.
 - 2. Thickness: 1/4 inch (6.0 mm) unless otherwise indicated.
- B. Uncoated Clear Tempered Glass Units:
 - 1. Class 1 (clear), Kind FT (fully tempered) float glass.
 - 2. Thickness: 1/4 inch (6.0 mm) unless otherwise indicated.

2.07 LAMINATED INSULATING GLASS UNITS

- A. Impact Resistant Passive Solar Low-E Insulating-Glass Units:
 - 1. Basis-of-Design Product: "Laminated Insulating" by Viracon or approved equal.
 - 2. Thicknesses:
 - a. Overall Unit 1-5/16 inch.
 - b. Exterior Lite: 2 plies of 1/4 inch glass laminated together with a .060" interlayer.
 - c. Interior lite: 1/4"
 - 3. Interspace Content: Air.
 - 4. Exterior Lites: Class 1 (clear), Kind FT (fully tempered).
 - 5. Indoor Lite:
 - a. Class 1 (clear), float glass.
 - b. Typical: Annealed
 - c. Provide Kind FT (fully tempered) where safety glazing is indicated.
 - 6. Low-E Coating: On #4 surface.
 - 7. Performance Requirements:
 - a. Visible Light Transmittance: 36 percent minimum.
 - b. Winter Nighttime U-Factor: 0.30 maximum.
 - c. Summer Daytime U-Factor: 0.28 maximum.
 - d. Solar Heat Gain Coefficient: 0.29 maximum.

PART 3 - EXECUTION

3.01 EXAMINATION

- A. Examine framing glazing, with Installer present, for compliance with the following:
 - 1. Manufacturing and installation tolerances, including those for size, squareness, and offsets at corners.
 - 2. Presence and functioning of weep system.
 - 3. Minimum required face or edge clearances.

- 4. Effective sealing between joints of glass-framing members.
- B. Proceed with installation only after unsatisfactory conditions have been corrected.

3.02 PREPARATION

- A. Clean glazing channels and other framing members receiving glass immediately before glazing. Remove coatings not firmly bonded to substrates.

3.03 GLAZING, GENERAL

- A. Comply with combined written instructions of manufacturers of glass, sealants, gaskets, and other glazing materials, unless more stringent requirements are indicated, including those in referenced glazing publications.
- B. Glazing channel dimensions, as indicated on Drawings, provide necessary bite on glass, minimum edge and face clearances, and adequate sealant thicknesses, with reasonable tolerances. Adjust as required by Project conditions during installation.
- C. Protect glass edges from damage during handling and installation. Remove damaged glass from Project site and legally dispose of off Project site. Damaged glass is glass with edge damage or other imperfections that, when installed, could weaken glass and impair performance and appearance.
- D. Apply primers to joint surfaces where required for adhesion of sealants, as determined by preconstruction sealant-substrate testing.
- E. Install setting blocks in sill rabbets, sized and located to comply with referenced glazing publications, unless otherwise required by glass manufacturer. Set blocks in thin course of compatible sealant suitable for heel bead.
- F. Do not exceed edge pressures stipulated by glass manufacturers for installing glass lites.
- G. Provide spacers for glass lites where length plus width is larger than 50 inches as follows:
 - 1. Locate spacers directly opposite each other on both inside and outside faces of glass. Install correct size and spacing to preserve required face clearances, unless gaskets are used that have demonstrated ability to maintain required face clearances and to comply with system performance requirements.
- H. Provide edge blocking where indicated or needed to prevent glass lites from moving sideways in glazing channel, as recommended in writing by glass manufacturer and according to requirements in referenced glazing publications.
- I. Set glass lites in each series with uniform pattern, draw, bow, and similar characteristics.

3.04 GASKET GLAZING (DRY)

- A. Fabricate compression gaskets in lengths recommended by gasket manufacturer to fit openings exactly, with allowance for stretch during installation.
- B. Insert soft compression gasket between glass and frame or fixed stop so it is securely in place with joints miter cut and bonded together at corners.
- C. Center glass lites in openings on setting blocks and press firmly against soft compression gasket by inserting dense compression gaskets formed and installed to lock in place against faces of removable stops. Start gasket applications at corners and work toward centers of openings. Compress gaskets to produce a weathertight seal

without developing bending stresses in glass. Seal gasket joints with sealant recommended by gasket manufacturer.

- D. Install gaskets so they protrude past face of glazing stops.

3.05 CLEANING AND PROTECTION

- A. Protect exterior glass from damage immediately after installation by attaching crossed streamers to framing held away from glass. Do not apply markers to glass surface. Remove nonpermanent labels, and clean surfaces.
- B. Protect glass from contact with contaminating substances resulting from construction operations, including weld splatter. If, despite such protection, contaminating substances do come into contact with glass, remove substances immediately as recommended by glass manufacturer.
- C. Examine glass surfaces adjacent to or below exterior concrete and other masonry surfaces at frequent intervals during construction, but not less than once a month, for buildup of dirt, scum, alkaline deposits, or stains; remove as recommended in writing by glass manufacturer.
- D. Remove and replace glass that is broken, chipped, cracked, or abraded or that is damaged from natural causes, accidents, and vandalism, during construction period.
- E. Wash glass on both exposed surfaces in each area of Project not more than four days before date scheduled for inspections that establish date of Substantial Completion. Wash glass as recommended in writing by glass manufacturer.

END OF SECTION

SECTION 09253 - GYPSUM SHEATHING

PART 1 - GENERAL

1.01 RELATED DOCUMENTS

- A. Drawings and general provisions of the Contract, including General and Supplementary Conditions and Division 1 Specification Sections, apply to this Section.
- B. Gypsum Association document GA-253 "Application of Gypsum Sheathing", most current edition.

1.02 SUMMARY

- A. Section includes glass-mat gypsum sheathing board.
- B. Related Sections include:
 - 1. Division 6 Section "Wood Frame Construction" for wood studs subject to gravity or wind loading.
 - 2. Division 7 Section "Sheet Metal Flashing and Trim" for flashing installed with gypsum sheathing.

1.03 DEFINITIONS

- A. Gypsum Board Construction Terminology Standard: Refer to ASTM C 11 for definitions of terms for gypsum sheathing board construction not defined in this Section or in other referenced standards.

1.04 SUBMITTALS

- A. Product Data: For each type of product indicated.

1.05 DELIVERY, STORAGE, AND HANDLING

- A. Store materials protected against damage from weather, direct sunlight, surface contamination, corrosion, construction traffic, or other causes. Stack sheathing flat on leveled supports off the ground, under cover, and fully protected from weather.

1.06 COORDINATION

- A. Glass-Mat Gypsum Sheathing Board: Do not leave exposed to weather for more than 180 days.

PART 2 - PRODUCTS

2.01 GYPSUM SHEATHING

- A. Glass-Mat Gypsum Sheathing Board: ASTM C 1177/C 1177M.
 - 1. Product: Subject to compliance with requirements, provide "Dens-Glass Gold" by G-P Gypsum Corporation or a comparable product approved by the Architect.
 - 2. Type and Thickness: Regular, 1/2 inch thick.
 - 3. Size: 48" wide by maximum length available.
 - 4. Performance Properties:
 - a. Resistance to Mold Growth (ASTM D 3273): 10 (indicates no mold detected).

- b. Permeance (ASTM E 96): 26 perms (maximum) for 1/2 inch thickness.
- c. "R" Value (ASTM C 518): [0.50 (minimum) for 1/2 inch thickness.

2.02 SHEATHING JOINT-AND-PENETRATION TREATMENT MATERIALS

- A. Sheathing Tape: Self-adhering permanent self-adhering, reinforced elastomeric tape for use on the joints of glass-mat gypsum sheathing board, recommended in writing by sheathing and tape manufacturers for use in sealing joints in glass-mat gypsum sheathing board and with a history of successful in-service use.
 - 1. Width: 2 inches (minimum).
 - 2. Physical Properties:
 - a. Thickness: 30 mils (minimum)
 - b. Water Absorption: Less than 0.6%, ASTM D 570
 - c. Water Vapor Transmission: Less than 0.05 perms
 - d. Salt Spray Test: No corrosion, ASTM D 1000
 - e. Peel Strength: Greater than 10 psi
 - 3. Primer for Sheathing Tape: Product recommended by manufacturer of sheathing tape for substrate.
 - 4. Product: Subject to compliance with requirements, provide "Universal Tape" by Roof Guardian Technologies or a comparable product approved by the Architect.

2.03 ACCESSORY MATERIALS

- A. Screws for Fastening Gypsum Sheathing to Wood Framing: Steel drill screws, in length recommended by sheathing manufacturer for thickness of sheathing board to be attached, with organic-polymer or other corrosion-protective coating having a salt-spray resistance of more than 800 hours according to ASTM B 117.

PART 3 - EXECUTION

3.01 GYPSUM SHEATHING INSTALLATION

- A. Comply with GA-253 and with manufacturer's written instructions.
 - 1. Fasten gypsum sheathing to cold-formed metal framing with screws.
 - 2. Install boards with a 3/8-inch gap where non-load-bearing construction abuts structural elements.
 - 3. Install boards with a 1/4-inch gap where they abut masonry or similar materials that might retain moisture, to prevent wicking.
- B. Apply fasteners so heads bear tightly against face of sheathing boards but do not cut into facing.
- C. Install fiberglass tape over joints between sheathing and at sheathing edges, per manufacturer's recommendations.
- D. Horizontal Installation: Install sheathing with V-grooved edge down and tongue edge up. Interlock tongue with groove to bring long edges in contact with edges of adjacent boards without forcing. Abut ends of boards over centers of studs, and stagger end joints of adjacent boards not less than one stud spacing. Attach boards at perimeter and within field of board to each stud.
 - 1. Space fasteners approximately 8 inches o.c. and set back a minimum of 3/8 inch from edges and ends of boards.

2. For sheathing under stucco cladding, boards may be initially tacked in place with screws if overlying self-furring metal lath is screw-attached through sheathing to studs immediately after sheathing is installed.
- E. Vertical Installation: Install board vertical edges centered over studs. Abut ends and edges of each board with those of adjacent boards. Attach boards at perimeter and within field of board to each stud.
1. Space fasteners approximately 8 inches o.c. and set back a minimum of 3/8 inch from edges and ends of boards.
 2. For sheathing under stucco cladding, boards may be initially tacked in place with screws if overlying self-furring metal lath is screw-attached through sheathing to studs immediately after sheathing is installed.

3.02 SHEATHING JOINT-AND-PENETRATION TREATMENT

- A. Seal sheathing joints according to written recommendations of sheathing board manufacturer and sheathing tape manufacturer.
1. Tape and Sealant Application:
 - a. Apply silicone sealant to joints and fasteners and trowel flat. Apply sufficient quantity of sealant to completely cover joints and fasteners after troweling.
 - b. Apply glass-fiber sheathing tape to glass-mat gypsum sheathing board joints, and apply and trowel silicone emulsion sealant to embed entire face of tape in sealant.
 2. Self-Adhering Tape Application:
 - a. If required by manufacturer, prime the substrate
 - b. Apply and firmly adhere 2-inch or 4-inch wide joint tape, per manufacturer's recommendation, using a 2-inch steel or hard rubber roller.
 - c. Apply tape to exposed fasteners so fasteners are completely covered.
- B. Seal other penetrations and openings.

END OF SECTION

SECTION 09260 - GYPSUM BOARD ASSEMBLIES

Section revised and reissued with Addendum 6. Tile backing panels added.

PART 1 - GENERAL

1.01 RELATED DOCUMENTS

- A. Drawings and general provisions of the Contract, including General and Supplementary Conditions and Division 1 Specification Sections, apply to this Section.

1.02 SUMMARY

- A. Section includes:
 - 1. Interior gypsum wallboard.
 - 2. Tile backing panels.
 - 3. Non-load-bearing steel framing.
- B. Related Sections include:
 - 1. Division 9 Section "Gypsum Sheathing" for installations over steel framing.

1.03 DEFINITIONS

- A. Gypsum Board Terminology: Refer to ASTM C 11 for definitions of terms for gypsum board assemblies not defined in this Section or in other referenced standards.

1.04 PERFORMANCE REQUIREMENTS

- A. Steel Framing: Metal thickness indicated are minimum thickness selected to meet structural design criteria for non-load-bearing, interior partitions. Where metal framing manufacturer's published Product Data recommends a greater thickness for the condition indicated, provide metal framing in recommended thickness.
 - 1. Lateral Load: 10 lbs/sq. ft.
 - 2. Maximum Allowable Deflection:
 - a. Typical Partitions: L/240.
 - b. Partitions to Receive Tile Finish: L/360.

1.05 SUBMITTALS

- A. Submit manufacturer's acknowledgement letter. Follow Division 1 Section "Submittal Procedures."
- B. Submit product data for each type of product indicated.
- C. Submit manufacturer's structural data for each type of metal framing required with charts indicating manufacturer's recommendations for limiting heights in accordance with specified performance.

1.06 QUALITY ASSURANCE

- A. Fire-Test-Response Characteristics:
 - 1. For gypsum board assemblies with fire-resistance ratings, provide materials and construction identical to those tested in assembly indicated according to ASTM E 119 by an independent testing and inspecting agency acceptable to authorities having jurisdiction.

2. Fire-Resistance-Rated Assemblies: Indicated by design designations from UL's "Fire Resistance Directory."

1.07 DELIVERY, STORAGE, AND HANDLING

- A. Deliver materials in original packages, containers, or bundles bearing brand name and identification of manufacturer or supplier.
- B. Store materials inside under cover and keep them dry and protected against damage from weather, direct sunlight, surface contamination, corrosion, construction traffic, and other causes. Stack gypsum panels flat to prevent sagging.

1.08 PROJECT CONDITIONS

- A. Environmental Limitations: Comply with ASTM C 840 requirements or gypsum board manufacturer's written recommendations, whichever are more stringent.

PART 2 - PRODUCTS

2.01 STEEL FRAMING

- A. Suspended Ceiling and Soffit Framing
 1. Components shall comply with ASTM C 754 for conditions indicated.
 2. Tie Wire: ASTM A 641/A 641M, Class 1 zinc coating, soft temper, 0.0625-inch-diameter wire, or double strand of 0.0475-inch-diameter wire.
 3. Hangers:
 - a. Wire Hangers: ASTM A 641/A 641M, Class 1 zinc coating, soft temper, 0.162-inch diameter.
 - b. Rod Hangers: ASTM A 510, mild carbon steel.
 - (1) Diameter: 7/32-inch, unless otherwise indicated.
 - (2) Protective Coating: Corrosion-resistant paint.
 - c. Flat Hangers: Commercial-steel sheet, ASTM A 366/A 366M, with corrosion-resistant paint finish.
 - (1) Size: 1 by 3/16 inch by length indicated, unless otherwise indicated.
 4. Carrying Channels: Cold-rolled, commercial-steel sheet with a base metal thickness of 0.0538 inch (16 ga.), a minimum 1/2-inch-wide flange, with manufacturer's standard corrosion-resistant zinc coating.
 - a. Depth: 1-1/2 inches, unless otherwise indicated.
 5. Furring Channels (Furring Members): Commercial-steel sheet with manufacturer's standard corrosion-resistant zinc coating.
 - a. Cold Rolled Channels: 0.0538-inch (16 ga.) bare steel thickness, with minimum 1/2-inch-wide flange, 3/4 inch deep.
 - b. Steel Studs: ASTM C 645.
 - (1) Minimum Base Metal Thickness: 0.0312 inch (20 ga.), unless otherwise indicated.
 - (2) Depth: As indicated.
 - c. Hat-Shaped, Rigid Furring Channels: ASTM C 645, 7/8 inch deep.
 - (1) Minimum Base Metal Thickness: 0.0179 inch (25 ga.), unless otherwise indicated.

6. Grid Suspension System for Interior Ceilings: ASTM C 645, direct-hung system composed of main beams and cross-furring members that interlock.
 - a. Available Products: Subject to compliance with requirements, products that may be incorporated into the Work include, but are not limited to, the following:
 - (1) Armstrong World Industries, Inc.; Furring Systems/Drywall.
 - (2) Chicago Metallic Corporation; Drywall Furring 640 System.
 - (3) USG Interiors, Inc.; Drywall Suspension System.
- B. Steel Partition And Soffit Framing:
 1. Components shall be as follows:
 - a. Comply with ASTM C 754 for conditions indicated.
 - b. Steel Sheet Components: Complying with ASTM C 645 requirements for metal and with manufacturer's standard corrosion-resistant zinc coating.
 2. Steel Studs and Runners: ASTM C 645.
 - a. Minimum Base Metal Thickness: 0.027 inch (22 ga.) 0.0312 inch (20 ga.), unless otherwise indicated.
 - b. Depth: As indicated.
 3. Deep-Leg Deflection Track: ASTM C 645 top runner with 2-inch-deep flanges.
 4. Proprietary Firestop Track: Top runner manufactured to allow partition heads to expand and contract with movement of the structure while maintaining continuity of fire-resistance-rated assembly indicated; in thickness not less than indicated for studs and in width to accommodate depth of studs.
 - a. Subject to compliance with requirements, products that may be incorporated into the Work include, but are not limited to, the following:
 - (1) Fire Trak Corp.; Fire Trak attached to studs with Fire Trak Slip Clip.
 - (2) Metal-Lite, Inc.; The System.
 5. Flat Strap and Backing Plate: Steel sheet for blocking and bracing in length and width indicated.
 - a. Minimum Base Metal Thickness: 0.0312 inch (20 ga.), unless otherwise indicated..
 6. Cold-Rolled Channel Bridging: 0.0538-inch (16 ga.) bare steel thickness, with minimum 1/2-inch-wide flange.
 - a. Depth: 1-1/2 inches, unless otherwise indicated.
 - b. Clip Angle: 1-1/2 by 1-1/2 inch, 0.068-inch-thick, galvanized steel.
 7. Hat-Shaped, Rigid Furring Channels: ASTM C 645.
 - a. Minimum Base Metal Thickness: 0.0179 inch (25 ga.), unless otherwise indicated.
 - b. Depth: 7/8 inch, unless otherwise indicated..
 8. Cold-Rolled Furring Channels: 0.0538-inch (16 ga.) bare steel thickness, with minimum 1/2-inch- wide flange.
 - a. Depth: 3/4 inch.
 - b. Furring Brackets: Adjustable, corrugated-edge type of steel sheet with minimum bare steel thickness of 0.0312 inch (20 ga.).

- c. Tie Wire: ASTM A 641/A 641M, Class 1 zinc coating, soft temper, 0.0625-inch-diameter wire, or double strand of 0.0475-inch-diameter wire.
- 9. Z-Shaped Furring: With slotted or nonslotted web, face flange of 1-1/4 inches, wall attachment flange of 7/8 inch, minimum bare metal thickness of 0.0179 inch (25 ga.), and depth required to fit insulation thickness indicated.
- 10. Fasteners for Metal Framing: Of type, material, size, corrosion resistance, holding power, and other properties required to fasten steel members to substrates.

2.02 INTERIOR GYPSUM WALLBOARD

- A. Panel Size: Provide in maximum lengths and widths available that will minimize joints in each area and correspond with support system indicated.
- B. Gypsum Wallboard: ASTM C 1396.
 - 1. Regular Type:
 - a. Thickness: 5/8 inch, unless otherwise indicated.
 - b. Long Edges: Tapered and featured (rounded or beveled) for prefilling.
 - c. Location: Vertical surfaces, unless otherwise indicated.
 - 2. Type X:
 - a. Thickness: 5/8 inch, unless otherwise indicated.
 - b. Long Edges: Tapered and featured (rounded or beveled) for prefilling.
 - c. Location: Where required for fire-resistance-rated assembly.
- C. Sag-Resistant Gypsum Wallboard: ASTM C 36, manufactured to have more sag resistance than regular-type gypsum board.
 - 1. Thickness: 1/2 inch.
 - 2. Long Edges: Tapered.
 - 3. Location: Ceiling surfaces.
- D. Proprietary, Special Fire-Resistive Type: ASTM C 36, having improved fire resistance over standard Type X.
 - 1. Subject to compliance with requirements, products that may be incorporated into the Work include, but are not limited to, the following:
 - a. G-P Gypsum Corp.; Firestop Type C.
 - b. National Gypsum Company; Gold Bond Fire-Shield G.
 - c. United States Gypsum Co.; SHEETROCK Brand Gypsum Panels, FIRECODE C Core.
 - 2. Thickness: 5/8 inch, unless otherwise indicated.
 - 3. Long Edges: Tapered and featured (rounded or beveled) for prefilling.
 - 4. Location: Where required for specific fire-resistance-rated assembly indicated.

2.03 TILE BACKING PANELS

- A. Provide in maximum lengths and widths available that will minimize joints in each area and correspond with support system indicated.
- B. Water-resistant gypsum board with fiberglass mat face.
 - 1. Acceptable manufacturer/product (or approved alternate): Georgia-Pacific "DensShield" tile backer board.

2.04 TRIM ACCESSORIES

- A. Interior Trim: ASTM C 1047.
 - 1. Material: Galvanized or aluminum-coated steel sheet or rolled zinc.
 - 2. Shapes:
 - a. Cornerbead: Use at outside corners.
 - b. LC-Bead: J-shaped; exposed long flange receives joint compound; use at exposed panel edges.
 - c. L-Bead: L-shaped; exposed long leg receives joint compound; use where indicated.
 - d. Expansion (Control) Joint: Use where indicated.
- B. Aluminum Trim: Extruded accessories of profiles and dimensions indicated.
 - 1. Available Manufacturers: Subject to compliance with requirements, manufacturers offering products that may be incorporated into the Work include, but are not limited to, the following:
 - a. Fry Reglet Corp.
 - b. Gordon, Inc.
 - c. MM Systems Corporation.
 - d. Pittcon Industries.
 - 2. Aluminum: Alloy and temper with not less than the strength and durability properties of ASTM B 221, alloy 6063-T5.
 - 3. Finish: Corrosion-resistant primer compatible with joint compound and finish materials specified.

2.05 JOINT TREATMENT MATERIALS

- A. Comply with ASTM C 475.
- B. Joint Tape:
 - 1. Interior Gypsum Wallboard: Paper.
 - 2. Tile Backing Panels: As recommended by panel manufacturer.
- C. Joint Compound for Interior Gypsum Wallboard: For each coat use formulation that is compatible with other compounds applied on previous or for successive coats.
 - 1. Prefilling: At open joints, rounded or beveled panel edges, and damaged surface areas, use setting-type taping compound.
 - 2. Embedding and First Coat: For embedding tape and first coat on joints, fasteners, and trim flanges, use setting-type taping compound.
 - 3. Fill Coat: For second coat, use setting-type, sandable topping compound.
 - 4. Finish Coat: For third coat, use setting-type, sandable topping compound.
- D. Joint Compound for Water-Resistant Gypsum Backing Board: Use setting-type taping and setting-type, sandable topping compounds.

2.06 ACOUSTICAL SEALANT

- A. Subject to compliance with requirements, products that may be incorporated into the Work include, but are not limited to, the following:
 - 1. Acoustical Sealant for Exposed and Concealed Joints:
 - a. Pecora Corp.; AC-20 FTR Acoustical and Insulation Sealant.

- b. United States Gypsum Co.; SHEETROCK Acoustical Sealant.
- B. Acoustical Sealant for Exposed and Concealed Joints: Nonsag, paintable, nonstaining, latex sealant complying with ASTM C 834 that effectively reduces airborne sound transmission through perimeter joints and openings in building construction as demonstrated by testing representative assemblies according to ASTM E 90.

2.07 AUXILIARY MATERIALS

- A. Provide auxiliary materials that comply with referenced installation standards and manufacturer's written recommendations.
- B. Laminating Adhesive: Adhesive or joint compound recommended for directly adhering gypsum panels to continuous substrate.
- C. Steel Drill Screws: ASTM C 1002, unless otherwise indicated.
 - 1. Use screws complying with ASTM C 954 for fastening panels to steel members from 0.033 (20 ga.) to 0.112 inch thick.
- D. Isolation Strip at Exterior Walls:
 - 1. Asphalt-Saturated Organic Felt: ASTM D 226, Type I (No. 15 asphalt felt), nonperforated.
 - 2. Foam Gasket: Adhesive-backed, closed-cell vinyl foam strips that allow fastener penetration without foam displacement, 1/8 inch thick, in width to suit steel stud size.
- E. Sound Attenuation Blankets: ASTM C 665, Type I (blankets without membrane facing) produced by combining thermosetting resins with mineral fibers manufactured from glass, slag wool, or rock wool.
 - 1. Fire-Resistance-Rated Assemblies: Comply with mineral-fiber requirements of assembly.
- F. Thermal Insulation: As specified in Division 7 Section "Thermal Insulation."

PART 3 - EXECUTION

3.01 EXAMINATION

- A. Examine areas and substrates, with Installer present, and including welded hollow-metal frames, cast-in anchors, and structural framing, for compliance with requirements and other conditions affecting performance. Proceed with installation only after unsatisfactory conditions have been corrected.

3.02 PREPARATION

- A. Suspended Ceilings: Coordinate installation of ceiling suspension systems with installation of overhead structure to ensure that inserts and other provisions for anchorages to building structure have been installed to receive ceiling hangers at spacing required to support ceilings and that hangers will develop their full strength.

3.03 INSTALLING STEEL FRAMING, GENERAL

- A. Installation Standards: ASTM C 754, and ASTM C 840 requirements that apply to framing installation.
- B. Install supplementary framing, blocking, and bracing at terminations in gypsum board assemblies to support fixtures, equipment services, heavy trim, grab bars, toilet accessories, furnishings, or similar construction. Comply with details indicated and with

gypsum board manufacturer's written recommendations or, if none available, with United States Gypsum's "Gypsum Construction Handbook."

- C. Isolate steel framing from building structure at locations indicated to prevent transfer of loading imposed by structural movement.
 - 1. Isolate ceiling assemblies where they abut or are penetrated by building structure.
 - 2. Isolate partition framing and wall furring where it abuts structure, except at floor. Install slip-type joints at head of assemblies that avoid axial loading of assembly and laterally support assembly.
 - a. Use deep-leg deflection track where indicated.
 - b. Use proprietary firestop track where indicated.
- D. Do not bridge building control and expansion joints with steel framing or furring members. Frame both sides of joints independently.

3.04 INSTALLING STEEL SUSPENDED CEILING AND SOFFIT FRAMING

- A. Suspend ceiling hangers from building structure as follows:
 - 1. Install hangers plumb and free from contact with insulation or other objects within ceiling plenum that are not part of supporting structural or ceiling suspension system. Splay hangers only where required to miss obstructions and offset resulting horizontal forces by bracing, countersplaying, or other equally effective means.
 - 2. Where width of ducts and other construction within ceiling plenum produces hanger spacings that interfere with the location of hangers required to support standard suspension system members, install supplemental suspension members and hangers in form of trapezes or equivalent devices. Size supplemental suspension members and hangers to support ceiling loads within performance limits established by referenced standards.
 - 3. Secure wire hangers by looping and wire-tying, either directly to structures or to inserts, eyescrews, or other devices and fasteners that are secure and appropriate for substrate, and in a manner that will not cause them to deteriorate or otherwise fail.
 - 4. Secure hangers to structure, including intermediate framing members, by attaching to inserts, eyescrews, or other devices and fasteners that are secure and appropriate for structure and hanger, and in a manner that will not cause hangers to deteriorate or otherwise fail.
 - 5. Do not support ceilings directly from permanent metal forms. Furnish cast-in-place hanger inserts that extend through forms.
 - 6. Do not attach hangers to steel deck tabs.
 - 7. Do not attach hangers to steel roof deck. Attach hangers to structural members.
 - 8. Do not connect or suspend steel framing from ducts, pipes, or conduit.
- B. Installation Tolerances: Install steel framing components for suspended ceilings so members for panel attachment are level to within 1/8 inch in 12 feet measured lengthwise on each member and transversely between parallel members.
- C. For exterior soffits, install cross bracing and framing to resist wind uplift.
- D. Wire-tie or clip furring channels to supports, as required to comply with requirements for assemblies indicated.

- E. Install suspended steel framing components in sizes and spacings indicated, but not less than that required by the referenced steel framing and installation standards.
 - 1. Hangers: 48 inches o.c., unless otherwise indicated.
 - 2. Carrying Channels (Main Runners): 48 inches o.c., unless otherwise indicated.
 - 3. Furring Channels (Furring Members): 16 inches o.c., unless otherwise indicated.
- F. Grid Suspension System: Attach perimeter wall track or angle where grid suspension system meets vertical surfaces. Mechanically join main beam and cross-furring members to each other and butt-cut to fit into wall track.

3.05 INSTALLING STEEL PARTITION AND SOFFIT FRAMING

- A. Install tracks (runners) at floors, ceilings, and structural walls and columns where gypsum board assemblies abut other construction.
 - 1. Where studs are installed directly against exterior walls, install asphalt-felt or foam-gasket isolation strip between studs and wall.
- B. Extend partition framing full height to structural supports or substrates above suspended ceilings, except where partitions are indicated to terminate at suspended ceilings. Continue framing over frames for doors and openings and frame around ducts penetrating partitions above ceiling to provide support for gypsum board.
 - 1. Cut studs 1/2 inch short of full height to provide perimeter relief. Do not fasten studs to top track to allow independent movement of studs and track.
 - 2. For fire-resistance-rated partitions that extend to the underside of floor/roof slabs and decks or other continuous solid-structure surfaces to obtain ratings, install framing around structural and other members extending below floor/roof slabs and decks, as needed to support gypsum board closures and to make partitions continuous from floor to underside of solid structure.
- C. Install steel studs and furring at the following spacings:
 - 1. Single-Layer Construction: 16 inches o.c., unless otherwise indicated.
- D. Install steel studs so flanges point in the same direction and leading edge or end of each panel can be attached to open (unsupported) edges of stud flanges first.
- E. Frame door openings to comply with GA-600 and with gypsum board manufacturer's applicable written recommendations, unless otherwise indicated. Screw vertical studs at jambs to jamb anchor clips on door frames; install runner track section (for cripple studs) at head and secure to jamb studs.
 - 1. Install two studs at each jamb, unless otherwise indicated.
 - 2. Install cripple studs at head adjacent to each jamb stud, with a minimum 1/2-inch clearance from jamb stud to allow for installation of control joint.
 - 3. Extend jamb studs through suspended ceilings and attach to underside of floor or roof structure above.
- F. Frame openings other than door openings the same as required for door openings, unless otherwise indicated. Install framing below sills of openings to match framing required above door heads.

3.06 APPLYING AND FINISHING PANELS, GENERAL

- A. Gypsum Board Application and Finishing Standards: ASTM C 840 and GA-216.

- B. Install sound attenuation blankets before installing gypsum panels, unless blankets are readily installed after panels have been installed on one side.
- C. Install ceiling board panels across framing to minimize the number of abutting end joints and to avoid abutting end joints in the central area of each ceiling. Stagger abutting end joints of adjacent panels not less than one framing member.
- D. Install gypsum panels with face side out. Butt panels together for a light contact at edges and ends with not more than 1/16 inch of open space between panels. Do not force into place.
- E. Locate edge and end joints over supports, except in ceiling applications where intermediate supports or gypsum board back-blocking is provided behind end joints. Do not place tapered edges against cut edges or ends. Stagger vertical joints on opposite sides of partitions. Do not make joints other than control joints at corners of framed openings.
- F. Attach gypsum panels to steel studs so leading edge or end of each panel is attached to open (unsupported) edges of stud flanges first.
- G. Attach gypsum panels to framing provided at openings and cutouts.
- H. Form control and expansion joints with space between edges of adjoining gypsum panels.
- I. Cover both faces of steel stud partition framing with gypsum panels in concealed spaces (above ceilings, etc.), except in chases braced internally.
 1. Unless concealed application is indicated or required for sound, fire, air, or smoke ratings, coverage may be accomplished with scraps of not less than 8 sq. ft. in area.
 2. Fit gypsum panels around ducts, pipes, and conduits.
 3. Where partitions intersect open concrete coffers, concrete joists, and other structural members projecting below underside of floor/roof slabs and decks, cut gypsum panels to fit profile formed by coffers, joists, and other structural members; allow 1/4- to 3/8-inch-wide joints to install sealant.
- J. Isolate perimeter of non-load-bearing gypsum board partitions at structural abutments. Provide 1/4- to 1/2-inch-wide spaces at these locations, and trim edges with U-bead edge trim where edges of gypsum panels are exposed. Seal joints between edges and abutting structural surfaces with acoustical sealant.
- K. Where sound attenuation batts are indicated to be installed in partitions, seal construction at perimeters, behind control and expansion joints, and at openings and penetrations with a continuous bead of acoustical sealant. Install acoustical sealant at both faces of partitions at perimeters and through penetrations. Comply with ASTM C 919 and manufacturer's written recommendations for locating edge trim.
- L. Space fasteners in gypsum panels according to referenced gypsum board application and finishing standard and manufacturer's written recommendations.
- M. Space fasteners in panels that are tile substrates a maximum of 8 inches o.c.

3.07 PANEL APPLICATION METHODS

- A. Single-Layer Application:
 1. On ceilings, apply gypsum panels before wall/partition board application to the greatest extent possible and at right angles to framing, unless otherwise indicated.

2. On partitions/walls, apply gypsum panels vertically (parallel to framing), unless otherwise indicated or required by fire-resistance-rated assembly, and minimize end joints.
 - a. Stagger abutting end joints not less than one framing member in alternate courses of board.
- B. Single-Layer Fastening Methods: Apply gypsum panels to supports with steel drill screws.
- C. Install water-resistant gypsum backing board at all toilet rooms partitions, and/or where indicated on Drawings. Install with 1/4-inch gap where panels abut other construction or penetrations.
 1. Where tile backing panels abut other types of panels in the same plane, shim surfaces to produce a uniform plane across panel surfaces.

3.08 INSTALLING TRIM ACCESSORIES

- A. For trim with back flanges intended for fasteners, attach to framing with same fasteners used for panels. Otherwise, attach trim according to manufacturer's written instructions.
- B. Install control joints at locations indicated on Drawings, or if not shown, install control joints according to ASTM C 840 and in specific locations approved by Architect for visual effect.

3.09 FINISHING GYPSUM BOARD ASSEMBLIES

- A. Treat gypsum board joints, interior angles, edge trim, control joints, penetrations, fastener heads, surface defects, and elsewhere as required to prepare gypsum board surfaces for decoration. Promptly remove residual joint compound from adjacent surfaces.
- B. Prefill open joints, rounded or beveled edges, and damaged surface areas.
- C. Apply joint tape over gypsum board joints, except those with trim having flanges not intended for tape.
- D. Gypsum Board Finish Levels: Finish panels to levels indicated below, according to ASTM C 840, for locations indicated:
 1. Level 1: Embed tape at joints in ceiling plenum areas, concealed areas, and where indicated, unless a higher level of finish is required for fire-resistance-rated assemblies and sound-rated assemblies.
 2. Level 4: Embed tape and apply separate first, fill, and finish coats of joint compound to tape, fasteners, and trim flanges at panel surfaces that will be exposed to view, unless otherwise indicated.
- E. Finish glass-mat, water-resistant backing panels according to manufacturer's written instructions.

END OF SECTION

SECTION 09310 - CERAMIC TILE

PART 1 - GENERAL

1.01 RELATED DOCUMENTS

- A. Drawings and general provisions of the Contract, including General and Supplementary Conditions and Division 1 Specification Sections, apply to this Section.

1.02 SUMMARY

- A. Section includes:
 - 1. Glazed porcelain tile.
 - 2. Glazed wall tile.
- B. Related Sections include:
 - 1. Division 3 Section "Cast-in-Place Concrete" for monolithic slab finishes specified for tile substrates.
 - 2. Division 7 Section "Joint Sealants" for sealing of expansion, contraction, control, and isolation joints in tile surfaces.

1.03 DEFINITIONS

- A. Module Size: Actual tile size (minor facial dimension as measured per ASTM C 499) plus joint width indicated.
- B. Facial Dimension: Nominal tile size as defined in ANSI A137.1.

1.04 PERFORMANCE REQUIREMENTS

- A. Static Coefficient of Friction: For tile installed on walkway surfaces, provide products with the following values as determined by testing identical products per ASTM C 1028:
 - 1. Level Surfaces: Minimum 0.6.
 - 2. Step Treads: Minimum 0.6.
 - 3. Ramp Surfaces: Minimum 0.8.

1.05 SUBMITTALS

- A. Manufacturer's Acknowledgement Letter: Follow Division 1 Section "Submittal Procedures."
- B. Submit product data for each type of product indicated.
- C. Submit samples for verification:
 - 1. Assembled samples with grouted joints for each type and composition of tile and for each color and finish required, at least 12 inches square and mounted on rigid panel. Use grout of type and in color or colors approved for completed work.
 - 2. Full-size units of each type of trim and accessory.
- D. Submit product certificates for each type of product, signed by product manufacturer.

1.06 QUALITY ASSURANCE

- A. Obtain all tile of same type and color or finish from one source or producer. Obtain tile from same production run and of consistent quality in appearance and physical properties for each contiguous area.
- B. Obtain ingredients of a uniform quality for each mortar, adhesive, and grout component from a single manufacturer and each aggregate from one source or producer.

1.07 DELIVERY, STORAGE, AND HANDLING

- A. Deliver and store packaged materials in original containers with seals unbroken and labels intact until time of use. Comply with requirement in ANSI A137.1 for labeling sealed tile packages.
- B. Store tile and cementitious materials on elevated platforms, under cover, and in a dry location.
- C. Store aggregates where grading and other required characteristics can be maintained and contamination avoided.
- D. Store emulsion adhesives in unopened containers and protected from freezing.
- E. Handle tile that has temporary protective coating on exposed surfaces to prevent coated surfaces from contacting backs or edges of other units. If coating does contact bonding surfaces of tile, remove coating from bonding surfaces before setting tile.

1.08 PROJECT CONDITIONS

- A. Environmental Limitations: Do not install tile until construction in spaces is complete and ambient temperature and humidity conditions are maintained at the levels indicated in referenced standards and manufacturer's written instructions.

PART 2 - PRODUCTS

2.01 MANUFACTURERS

- A. In other Part 2 articles where titles below introduce lists, the following requirements apply for product selection:
 - 1. Subject to compliance with requirements, manufacturers offering products that may be incorporated into the Work include, but are not limited to, the manufacturers specified.
 - 2. The design for each tile type is based on the product named. Subject to compliance with requirements, provide either the named product or a comparable product by one of the other manufacturers specified.

2.02 PRODUCTS, GENERAL

- A. Provide tile that complies with ANSI A137.1, "Specifications for Ceramic Tile," for types, compositions, and other characteristics indicated.
 - 1. Provide tile complying with Standard grade requirements, unless otherwise indicated.
 - 2. For facial dimensions of tile, comply with requirements relating to tile sizes specified in Part 1 "Definitions" Article.
- B. Provide materials complying with ANSI standards referenced in "Setting and Grouting Materials" Article.

- C. Where manufacturer's standard products are indicated for tile, grout, and other products requiring selection of colors, surface textures, patterns, and other appearance characteristics, provide specific products or materials complying with the following requirements:
 - 1. As selected by Architect from manufacturer's full range.
- D. For tile exhibiting color variations within ranges selected during Sample submittals, blend tile in factory and package so tile units taken from one package show same range in colors as those taken from other packages and match approved Samples.
- E. For factory-mounted tile, provide back- or edge-mounted tile assemblies as standard with manufacturer, unless otherwise indicated.
- F. Where indicated under tile type, protect exposed surfaces of tile against adherence of mortar and grout by precoating with continuous film of petroleum paraffin wax, applied hot. Do not coat unexposed tile surfaces.

2.03 TILE PRODUCTS

- A. Glazed Ceramic Mosaic Tile:
 - 1. Factory-mounted flat tile
 - 2. Composition: Vitreous or impervious natural clay or porcelain.
 - 3. Module Size: 3 by 6 inches.
 - 4. Thickness: 3/8 inch.
 - 5. Face: Bevel with cushion edges.
 - 6. Finish: Semi-gloss.
 - 7. Color: White 0100(2)
 - 8. Basis-of-Design Product: Daltile Rittenhouse Square Subway Tile.
- B. Glazed Floor Tile:
 - 1. Flat tile
 - 2. Module Size: 12 by 24 inches.
 - 3. Thickness: 3/8 inch.
 - 4. Face: Plain with cushion edges.
 - 5. Finish: Slip resistant
 - 6. Color: Intensity Pebble VL72
 - 7. Basis-of-Design Product: Daltile Volume 1.0.
- C. Glazed Wall Tile Trim Units: Matching characteristics of adjoining flat tile and coordinated with sizes and coursing of adjoining flat tile where applicable. Provide shapes as follows, selected from manufacturer's standard shapes:
 - 1. Base for Thin-Set Mortar Installations: Cove base, module size 3 by 6 inches.
 - 2. Wainscot Cap for Thin-Set Mortar Installations: Surface bullnose, module size 3 by 6 inches.
 - 3. External Corners for Thin-Set Mortar Installations: Surface bullnose.
 - 4. Internal Corners: Field-buttet square corners except with coved base and cap angle pieces designed to fit with stretcher shapes.

2.04 SETTING AND GROUTING MATERIALS

- A. Available Manufacturers:
 - 1. Bonsal, W. R., Company.

2. Bostik.
 3. C-Cure.
 4. DAP, Inc.
 5. LATICRETE International Inc.
 6. MAPEI Corporation.
 7. Southern Grouts & Mortars, Inc.
 8. Summitville Tiles, Inc.
- B. Latex-Portland Cement Mortar (Thin Set): ANSI A118.4, consisting of the following:
1. Prepackaged dry-mortar mix containing dry, redispersible, ethylene vinyl acetate additive to which only water must be added at Project site.
 - a. For wall applications, provide nonsagging mortar that complies with Paragraph F-4.6.1 in addition to the other requirements in ANSI A118.4.
- C. Polymer-Modified Tile Grout: ANSI A118.7, color as indicated.
1. Polymer Type: Ethylene vinyl acetate, in dry, redispersible form, prepackaged with other dry ingredients.
 - a. Unsanded grout mixture for joints 1/8 inch and narrower.
 - b. Sanded grout mixture for joints 1/8 inch and wider.

2.05 CEMENTITIOUS BACKER UNITS

- A. Provide cementitious backer units complying with ANSI A118.9 in maximum lengths available to minimize end-to-end butt joints.
1. Provide manufacturer's standard thickness, but not less than 5/8 inch, unless otherwise indicated.
 2. Provide manufacturer's standard width, but not less than 32 inches.
- B. Available Products:
1. C-Cure; C-Cure Board 990.
 2. Custom Building Products; Wonderboard.
 3. USG Corporation; Durock Cement Board.

2.06 MISCELLANEOUS MATERIALS

- A. Trowelable Underlayments and Patching Compounds: Latex-modified, portland cement-based formulation provided or approved by manufacturer of tile-setting materials for installations indicated.

2.07 MIXING MORTARS AND GROUT

- A. Mix mortars and grouts to comply with referenced standards and mortar and grout manufacturers' written instructions.
- B. Add materials, water, and additives in accurate proportions.
- C. Obtain and use type of mixing equipment, mixer speeds, mixing containers, mixing time, and other procedures to produce mortars and grouts of uniform quality with optimum performance characteristics for installations indicated.

PART 3 - EXECUTION

3.01 EXAMINATION

- A. Examine substrates, areas, and conditions where tile will be installed, with Installer present, for compliance with requirements for installation tolerances and other conditions affecting performance of installed tile.
 - 1. Verify that substrates for setting tile are firm; dry; clean; free of oil, waxy films, and curing compounds; and within flatness tolerances required by referenced ANSI A108 Series of tile installation standards for installations indicated.
 - 2. Verify that installation of grounds, anchors, recessed frames, electrical and mechanical units of work, and similar items located in or behind tile has been completed before installing tile.
 - 3. Verify that joints and cracks in tile substrates are coordinated with tile joint locations; if not coordinated, adjust joint locations in consultation with Architect.
- B. Proceed with installation only after unsatisfactory conditions have been corrected.

3.02 PREPARATION

- A. Remove coatings, including curing compounds and other substances that contain soap, wax, oil, or silicone, that are incompatible with tile-setting materials.
- B. Provide concrete substrates for tile floors installed with **[adhesives] [or] [thin-set mortar]** that comply with flatness tolerances specified in referenced ANSI A108 Series of tile installation standards.
 - 1. Fill cracks, holes, and depressions with trowelable leveling and patching compound according to tile-setting material manufacturer's written instructions. Use product specifically recommended by tile-setting material manufacturer.
 - 2. Remove protrusions, bumps, and ridges by sanding or grinding.
- C. For tile exhibiting color variations within ranges selected during Sample submittals, verify that tile has been factory blended and packaged so tile units taken from one package show same range of colors as those taken from other packages and match approved Samples. If not factory blended, either return to manufacturer or blend tiles at Project site before installing.

3.03 INSTALLATION, GENERAL

- A. ANSI Tile Installation Standards: Comply with parts of ANSI A108 Series "Specifications for Installation of Ceramic Tile" that apply to types of setting and grouting materials and to methods indicated in ceramic tile installation schedules.
- B. TCA Installation Guidelines: TCA's "Handbook for Ceramic Tile Installation." Comply with TCA installation methods indicated in ceramic tile installation schedules.
- C. Extend tile work into recesses and under or behind equipment and fixtures to form complete covering without interruptions, unless otherwise indicated. Terminate work neatly at obstructions, edges, and corners without disrupting pattern or joint alignments.
- D. Accurately form intersections and returns. Perform cutting and drilling of tile without marring visible surfaces. Carefully grind cut edges of tile abutting trim, finish, or built-in items for straight aligned joints. Fit tile closely to electrical outlets, piping, fixtures, and other penetrations so plates, collars, or covers overlap tile.
- E. Lay tile in grid pattern, unless otherwise indicated. Align joints when adjoining tiles on floor, base, walls, and trim are same size. Lay out tile work and center tile fields in both

directions in each space or on each wall area. Adjust to minimize tile cutting. Provide uniform joint widths, unless otherwise indicated.

- F. Lay out tile wainscots to next full tile beyond dimensions indicated.
- G. Locate expansion joints and other sealant-filled joints, including control, contraction, and isolation joints, where indicated during installation of setting materials, mortar beds, and tile. Do not saw-cut joints after installing tiles.
 - 1. Locate joints in tile surfaces directly above joints in concrete substrates.
 - 2. Prepare joints and apply sealants to comply with requirements in Division 7 Section "Joint Sealants."
- H. Grout tile to comply with requirements of the following tile installation standards:
 - 1. For ceramic tile grouts (sand-portland cement; dry-set, commercial portland cement; and latex-portland cement grouts), comply with ANSI A108.10.

3.04 FLOOR TILE INSTALLATION

- A. Install tile to comply with requirements in the Floor Tile Installation Schedule, including those referencing TCA installation methods and ANSI A108 Series of tile installation standards.
 - 1. Follow procedures in ANSI A108 Series tile installation standards for providing 95 percent mortar coverage.
- B. Install tile on floors with the 1/16" joint width.

3.05 WALL TILE INSTALLATION

- A. Install types of tile designated for wall installations to comply with requirements in the Wall Tile Installation Schedule, including those referencing TCA installation methods and ANSI setting-bed standards.
- B. Install metal lath and scratch coat for walls to comply with ANSI A108.1A, Section 4.1.
- C. Joint Widths: Install tile on walls with the 1/16" joint widths.

3.06 CLEANING AND PROTECTING

- A. On completion of placement and grouting, clean all ceramic tile surfaces so they are free of foreign matter.
 - 1. Remove latex-portland cement grout residue from tile as soon as possible.
 - 2. Clean grout smears and haze from tile according to tile and grout manufacturer's written instructions, but no sooner than 10 days after installation. Use only cleaners recommended by tile and grout manufacturers and only after determining that cleaners are safe to use by testing on samples of tile and other surfaces to be cleaned. Protect metal surfaces and plumbing fixtures from effects of cleaning. Flush surfaces with clean water before and after cleaning.
- B. Prohibit foot and wheel traffic from tiled floors for at least seven days after grouting is completed.
- C. Before final inspection, remove protective coverings and rinse neutral cleaner from tile surfaces.

END OF SECTION

SECTION 09511 - ACOUSTICAL PANEL CEILINGS

PART 1 - GENERAL

1.01 RELATED DOCUMENTS

- A. Drawings and general provisions of the Contract, including General and Supplementary Conditions and Division 1 Specification Sections, apply to this Section.

1.02 SUMMARY

- A. Section includes acoustical panels and exposed suspension systems for ceilings.

1.03 DEFINITIONS

- A. AC: Articulation Class.
- B. CAC: Ceiling Attenuation Class.
- C. LR: Light Reflectance coefficient.
- D. NRC: Noise Reduction Coefficient.

1.04 SUBMITTALS

- A. Submit manufacturer's acknowledgement letter. Follow Division 1 Section "Submittal Procedures."
- B. Submit product data for each type of product indicated.
- C. Submit samples for verification for each component indicated and for each exposed finish required, prepared on Samples of size indicated below.
 - 1. Acoustical Panel: Set of 6-inch- square Samples of each type, color, pattern, and texture.
 - 2. Exposed Suspension System Members, Moldings, and Trim: Set of 12-inch-long Samples of each type, finish, and color.
- D. Product Test Reports: Based on evaluation of comprehensive tests performed by a qualified testing agency, for each acoustical panel ceiling.
- E. Research/Evaluation Reports: For each acoustical panel ceiling and components.
- F. Maintenance Data: For finishes to include in maintenance manuals.

1.05 QUALITY ASSURANCE

- A. Source Limitations:
 - 1. Acoustical Ceiling Panel: Obtain each type through one source from a single manufacturer.
 - 2. Suspension System: Obtain each type through one source from a single manufacturer.

1.06 DELIVERY, STORAGE, AND HANDLING

- A. Deliver acoustical panels, suspension system components, and accessories to Project site in original, unopened packages and store them in a fully enclosed, conditioned space where they will be protected against damage from moisture, humidity, temperature extremes, direct sunlight, surface contamination, and other causes.

- B. Before installing acoustical panels, permit them to reach room temperature and a stabilized moisture content.
- C. Handle acoustical panels carefully to avoid chipping edges or damaging units in any way.

1.07 PROJECT CONDITIONS

- A. Environmental Limitations: Do not install acoustical panel ceilings until spaces are enclosed and weatherproof, wet work in spaces is complete and dry, work above ceilings is complete, and ambient temperature and humidity conditions are maintained at the levels indicated for Project when occupied for its intended use.

1.08 COORDINATION

- A. Coordinate layout and installation of acoustical panels and suspension system with other construction that penetrates ceilings or is supported by them, including light fixtures, HVAC equipment, fire-suppression system, and partition assemblies.

1.09 EXTRA MATERIALS

- A. Furnish extra materials described below that match products installed and that are packaged with protective covering for storage and identified with labels describing contents.
 - 1. Acoustical Ceiling Panels: Full-size panels equal to 2.0 percent of quantity installed.
 - 2. Suspension System Components: Quantity of each exposed component equal to 2.0 percent of quantity installed.

PART 2 - PRODUCTS

2.01 MANUFACTURERS

- A. In other Part 2 articles where titles below introduce lists, the following requirements apply for product selection:
 - 1. Available Products: Subject to compliance with requirements, products that may be incorporated into the Work include, but are not limited to, the products specified.
 - 2. Products: Subject to compliance with requirements, provide one of the products specified.
 - 3. Available Manufacturers: Subject to compliance with requirements, manufacturers offering products that may be incorporated into the Work include, but are not limited to, the manufacturers specified.
 - 4. Manufacturers: Subject to compliance with requirements, provide products by the manufacturers specified.

2.02 ACOUSTICAL PANELS

- A. Provide manufacturer's standard panels of configuration indicated that comply with ASTM E 1264 classifications as designated by types, patterns, acoustical ratings, and light reflectances, unless otherwise indicated.
 - a. Mounting Method for Measuring NRC: Type E-400; plenum mounting in which face of test specimen is 15-3/4 inches away from test surface per ASTM E 795.

2. Acoustical Panel Colors and Patterns: Match appearance characteristics indicated for each product type.
 - a. Where appearance characteristics of acoustical panels are indicated by referencing pattern designations in ASTM E 1264 and not manufacturers' proprietary product designations, provide products selected by Architect from each manufacturer's full range that comply with requirements indicated for type, pattern, color, light reflectance, acoustical performance, edge detail, and size.
 3. Coating-Based Antimicrobial Treatment: Provide acoustical panels with face and back surfaces coated with antimicrobial treatment consisting of manufacturer's standard formulation with fungicide added to inhibit growth of mold and mildew and showing no mold or mildew growth when tested according to ASTM D 3273.
- B. Water-Felted, Mineral-Base Acoustical Panels:
1. Basis of Design Product: "Cortega" by Armstrong
 2. Classification: Provide panels complying with ASTM E 1264 for Type III, mineral base with painted finish; Form 2, water felted; and pattern as follows:
 - a. Pattern: C (perforated, small holes).
 3. Color: White.
 4. LR: Not less than 0.80.
 5. NRC: Not less than 0.5.
 6. Edge Detail: Square.
 7. Thickness: 5/8 inch.
 8. Size: As indicated on Drawings.
- C. Vinyl-laminated face with sealed back and edges:
1. Basis of Design Product: "ClimaPlus 3270" by USG
 2. For use in clean room environments up to Class 100:
 3. Pattern: smooth textured.
 4. Color: Flat White.
 5. LR: 0.77.
 6. Edge Detail: Square.
 7. Thickness: 1/2 inch.
 8. Size: 24" x 24".

2.03 METAL SUSPENSION SYSTEMS, GENERAL

- A. Provide manufacturer's standard direct-hung metal suspension systems of types, structural classifications, and finishes indicated that comply with applicable requirements in ASTM C 635.
- B. Comply with NAAMM's "Metal Finishes Manual for Architectural and Metal Products" for recommendations for applying and designating finishes. Provide manufacturer's standard factory-applied finish for type of system indicated.
- C. Attachment Devices: Size for five times the design load indicated in ASTM C 635, Table 1, "Direct Hung," unless otherwise indicated.
- D. Wire Hangers, Braces, and Ties: Provide wires complying with the following requirements:

1. Zinc-Coated Carbon-Steel Wire: ASTM A 641/A 641M, Class 1 zinc coating, soft temper.
 2. Size: Select wire diameter so its stress at three times hanger design load (ASTM C 635, Table 1, "Direct Hung") will be less than yield stress of wire, but provide not less than 0.106-inch-diameter wire.
- E. Hanger Rods: Mild steel, zinc coated or protected with rust-inhibitive paint.
- F. Angle Hangers: Angles with legs not less than 7/8 inch wide; formed with 0.04-inch-thick, galvanized steel sheet complying with ASTM A 653/A 653M, G90 coating designation; with bolted connections and 5/16-inch-diameter bolts.

2.04 METAL SUSPENSION SYSTEMS

- A. Products: "Prelude XL" by Armstrong
- B. Wide-Face, Capped, Double-Web, Steel Suspension System: Main and cross runners roll formed from cold-rolled steel sheet, prepainted, electrolytically zinc coated, or hot-dip galvanized according to ASTM A 653/A 653M, not less than G30 coating designation, with prefinished 15/16-inch-wide metal caps on flanges.
1. Structural Classification: Heavy-duty system.
 2. End Condition of Cross Runners: Override (stepped) type.
 3. Face Design: Flat, flush.
 4. Cap Material: Steel cold-rolled sheet.
 5. Cap Finish: Painted white.

2.05 METAL EDGE MOLDINGS AND TRIM

- A. Manufacturers:
1. Armstrong World Industries, Inc.
 2. Celotex Corporation; Architectural Ceilings Marketing Dept.
 3. Chicago Metallic Corporation.
 4. Fry Reglet Corporation.
 5. Gordon, Inc.
 6. USG Interiors, Inc.
- B. Roll-Formed Sheet-Metal Edge Moldings and Trim: Type and profile indicated or, if not indicated, manufacturer's standard moldings for edges and penetrations that fit acoustical panel edge details and suspension systems indicated; formed from sheet metal of same material, finish, and color as that used for exposed flanges of suspension system runners.
1. For circular penetrations of ceiling, provide edge moldings fabricated to diameter required to fit penetration exactly.

2.06 ACOUSTICAL SEALANT

- A. Products; Acoustical Sealant for Exposed and Concealed Joints:
1. Pecora Corp; AC-20 FTR Acoustical and Insulation Sealant.
 2. United States Gypsum Co.; SHEETROCK Acoustical Sealant.
- B. Acoustical Sealant for Exposed and Concealed Joints: Manufacturer's standard nonsag, paintable, nonstaining latex sealant complying with ASTM C 834 and effective in reducing airborne sound transmission through perimeter joints and openings in building

construction as demonstrated by testing representative assemblies according to ASTM E 90.

PART 3 - EXECUTION

3.01 EXAMINATION

- A. Examine substrates, areas, and conditions, including structural framing to which acoustical panel ceilings attach or abut, with Installer present, for compliance with requirements specified in this and other Sections that affect ceiling installation and anchorage and with requirements for installation tolerances and other conditions affecting performance of acoustical panel ceilings.
- B. Proceed with installation only after unsatisfactory conditions have been corrected.

3.02 PREPARATION

- A. Measure each ceiling area and establish layout of acoustical panels to balance border widths at opposite edges of each ceiling. Avoid using less-than-half-width panels at borders, and comply with layout shown on reflected ceiling plans.

3.03 INSTALLATION, GENERAL

- A. General: Install acoustical panel ceilings to comply with ASTM C 636, per manufacturer's written instructions and CISCA's "Ceiling Systems Handbook."
- B. Suspend ceiling hangers from building's structural members and as follows:
 - 1. Install hangers plumb and free from contact with insulation or other objects within ceiling plenum that are not part of supporting structure or of ceiling suspension system.
 - 2. Splay hangers only where required to miss obstructions; offset resulting horizontal forces by bracing, countersplaying, or other equally effective means.
 - 3. Where width of ducts and other construction within ceiling plenum produces hanger spacings that interfere with location of hangers at spacings required to support standard suspension system members, install supplemental suspension members and hangers in form of trapezes or equivalent devices. Size supplemental suspension members and hangers to support ceiling loads within performance limits established by referenced standards and publications.
 - 4. Secure wire hangers to ceiling suspension members and to supports above with a minimum of three tight turns. Connect hangers directly either to structures or to inserts, eye screws, or other devices that are secure and appropriate for substrate and that will not deteriorate or otherwise fail due to age, corrosion, or elevated temperatures.
 - 5. Secure flat, angle, channel, and rod hangers to structure, including intermediate framing members, by attaching to inserts, eye screws, or other devices that are secure and appropriate for both structure to which hangers are attached and type of hanger involved. Install hangers in a manner that will not cause them to deteriorate or fail due to age, corrosion, or elevated temperatures.
 - 6. Do not attach hangers to roof deck. Attach hangers to structural members.
 - 7. Space hangers not more than 48 inches o.c. along each member supported directly from hangers, unless otherwise indicated; provide hangers not more than 8 inches from ends of each member.

- C. Install edge moldings and trim of type indicated at perimeter of acoustical ceiling area and where necessary to conceal edges of acoustical panels.
 - 1. Apply acoustical sealant in a continuous ribbon concealed on back of vertical legs of moldings before they are installed.
 - 2. Screw attach moldings to substrate at intervals not more than 16 inches o.c. and not more than 3 inches from ends, leveling with ceiling suspension system to a tolerance of 1/8 inch in 12 feet. Miter corners accurately and connect securely.
 - 3. Do not use exposed fasteners, including pop rivets, on moldings and trim.
- D. Install suspension system runners so they are square and securely interlocked with one another. Remove and replace dented, bent, or kinked members.
- E. Install acoustical panels with undamaged edges and fit accurately into suspension system runners and edge moldings. Scribe and cut panels at borders and penetrations to provide a neat, precise fit.
 - 1. Arrange directionally patterned acoustical panels as follows:
 - a. Install panels with pattern running in one direction parallel to long axis of space.
 - 2. For square-edged panels, install panels with edges fully hidden from view by flanges of suspension system runners and moldings.

3.04 CLEANING

- A. Clean exposed surfaces of acoustical panel ceilings, including trim, edge moldings, and suspension system members. Comply with manufacturer's written instructions for cleaning and touchup of minor finish damage. Remove and replace ceiling components that cannot be successfully cleaned and repaired to permanently eliminate evidence of damage.

END OF SECTION

SECTION 09651 – RESILIENT FLOOR TILE

PART 1 - GENERAL

1.01 RELATED DOCUMENTS

- A. Drawings and general provisions of the Contract, including General and Supplementary Conditions and Division 1 Specification Sections, apply to this Section.

1.02 SUMMARY

- A. Section includes:
 - 1. Luxury vinyl tile (LVT).
 - 2. Resilient wall base and accessories.

1.03 SUBMITTALS

- A. Submit Manufacturer's Acknowledgement Letter. Follow Division 1 Section "Submittal Procedures."
- B. Submit product data for each type of product indicated.
- C. Submit samples for verification:
 - 1. Full-size units of each color and pattern of resilient floor tile required.
 - 2. Resilient Wall Base and Accessories: Manufacturer's standard-size Samples, but not less than 12 inches long, of each resilient product color and pattern required.
- D. Submit maintenance data for resilient products to include in maintenance manuals.

1.04 DELIVERY, STORAGE, AND HANDLING

- A. Store resilient products and installation materials in dry spaces protected from the weather, with ambient temperatures maintained within range recommended by manufacturer, but not less than 50 deg F or more than 90 deg F. Store tiles on flat surfaces.

1.05 PROJECT CONDITIONS

- A. Maintain temperatures within range recommended by manufacturer, but not less than 65 deg F or more than 95 deg F, in spaces to receive floor tile during the following time periods:
 - 1. 48 hours before installation.
 - 2. During installation.
 - 3. 48 hours after installation.
- B. After postinstallation period, maintain temperatures within range recommended by manufacturer, but not less than 55 deg F or more than 95 deg F.
- C. Close spaces to traffic during floor covering installation.
- D. Close spaces to traffic for 48 hours after floor covering installation.
- E. Install resilient products after other finishing operations, including painting, have been completed.

1.06 EXTRA MATERIALS

- A. Furnish extra materials described below that match products installed and that are packaged with protective covering for storage and identified with labels describing contents.
 - 1. Floor Tile: Furnish 1 box for every 50 boxes or fraction thereof, of each type, color, and pattern of floor tile installed.
 - 2. Resilient Wall Base and Accessories: Furnish not less than 10 linear feet for every 500 linear feet or fraction thereof, of each type, color, pattern, and size of resilient product installed.

PART 2 - PRODUCTS

2.01 MANUFACTURERS

- A. Subject to compliance with requirements, provide one of the products listed in other Part 2 articles.

2.02 COLORS AND PATTERNS

- A. Colors and patterns shall be as selected by Architect from manufacturer's full range.

2.03 LUXURY VINYL TILE

- A. Luxury Vinyl Tile: Solid vinyl tile, ASTM F 1700, Class III, Type B – embossed surface.
 - 1. Karndean Design Flooring “KP99 Lime Washed Oak”
- B. Overall thickness: 0.125 inch.
- C. Wear layer thickness: 0.030 inch
- D. Size and color: 6” x 36”.
- E. Finish: UV-cured polyurethane
- F. Installation: Full spread adhesives

2.04 RESILIENT WALL BASE

- A. Wall Base: ASTM F 1861.
 - 1. Acceptable manufacturer: Roppe Corporation.
- B. Type (Material Requirement): TS (rubber, vulcanized thermoset)
- C. Group (Manufacturing Method): I (solid, homogeneous).
- D. Style: Cove (with top-set toe)
- E. Minimum Thickness: 0.125 inch.
- F. Height: 4 inches
- G. Lengths: Coils in manufacturer's standard length.
- H. Corners: Job formed.

2.05 RESILIENT MOLDING ACCESSORY

- A. Description (furnish products as required): Nosing for carpet, nosing for resilient floor covering, reducer strip for resilient floor covering, Joiner for tile and carpet.
 - 1. Acceptable manufacturer: Roppe Corporation.
- B. Material: Rubber.

- C. Profile and Dimensions: As required.

2.06 INSTALLATION MATERIALS

- A. Trowelable Leveling and Patching Compounds: Latex-modified, portland cement based or blended hydraulic cement based formulation provided or approved by resilient product manufacturer for applications indicated.
- B. Adhesives: Water-resistant type recommended by manufacturer to suit resilient products and substrate conditions indicated.

PART 3 - EXECUTION

3.01 EXAMINATION

- A. Examine substrates, with Installer present, for compliance with requirements for installation tolerances, moisture content, and other conditions affecting performance.
 - 1. Proceed with installation only after unsatisfactory conditions have been corrected.

3.02 PREPARATION

- A. Prepare substrates according to manufacturer's written recommendations to ensure adhesion of resilient products.
- B. Concrete Substrates: Prepare according to ASTM F 710.
 - 1. Verify that substrates are dry and free of curing compounds, sealers, and hardeners.
 - 2. Alkalinity and Adhesion Testing: Perform tests recommended by manufacturer. Proceed with installation only after substrates pass testing.
 - 3. Moisture Testing:
 - a. Perform anhydrous calcium chloride test, ASTM F 1869. Proceed with installation only after substrates have maximum moisture-vapor-emission rate of 3 lb of water/1000 sq. ft. in 24 hours.
 - b. Perform tests recommended by manufacturer. Proceed with installation only after substrates pass testing.
- C. Remove substrate coatings and other substances that are incompatible with adhesives and that contain soap, wax, oil, or silicone, using mechanical methods recommended by manufacturer. Do not use solvents.
- D. Use trowelable leveling and patching compound to fill cracks, holes, and depressions in substrates.
- E. Move resilient products and installation materials into spaces where they will be installed at least 48 hours in advance of installation.
 - 1. Do not install resilient products until they are same temperature as space where they are to be installed.
- F. Sweep and vacuum clean substrates to be covered by resilient products immediately before installation. After cleaning, examine substrates for moisture, alkaline salts, carbonation, and dust. Proceed with installation only after unsatisfactory conditions have been corrected.

3.03 TILE INSTALLATION

- A. Lay out tiles from center marks established with principal walls, discounting minor offsets, so tiles at opposite edges of room are of equal width. Adjust as necessary to avoid using cut widths that equal less than one-half tile at perimeter.
 - 1. Lay tiles square with room axis unless otherwise indicated.
- B. Match tiles for color and pattern by selecting tiles from cartons in the same sequence as manufactured and packaged, if so numbered. Discard broken, cracked, chipped, or deformed tiles.
 - 1. Lay tiles with grain running in one direction.
- C. Scribe, cut, and fit tiles to butt neatly and tightly to vertical surfaces and permanent fixtures including built-in furniture, cabinets, pipes, outlets, edgings, door frames, thresholds, and nosings.
- D. Extend tiles into toe spaces, door reveals, closets, and similar openings.
- E. Maintain reference markers, holes, and openings that are in place or marked for future cutting by repeating on floor tiles as marked on substrates. Use chalk or other nonpermanent, nonstaining marking device.
- F. Adhere tiles to flooring substrates using a full spread of adhesive applied to substrate to produce a completed installation without open cracks, voids, raising and puckering at joints, telegraphing of adhesive spreader marks, and other surface imperfections.

3.04 RESILIENT WALL BASE INSTALLATION

- A. Apply wall base to walls, columns, pilasters, casework and cabinets in toe spaces, and other permanent fixtures in rooms and areas where base is required.
- B. Install wall base in lengths as long as practicable without gaps at seams and with tops of adjacent pieces aligned.
- C. Tightly adhere wall base to substrate throughout length of each piece, with base in continuous contact with horizontal and vertical substrates.
- D. Do not stretch wall base during installation.
- E. On masonry surfaces or other similar irregular substrates, fill voids along top edge of wall base with manufacturer's recommended adhesive filler material.
- F. Job-Formed Corners:
 - 1. Outside Corners: Use straight pieces of maximum lengths possible. Form without producing discoloration (whitening) at bends. Shave back of base at points where bends occur and remove strips perpendicular to length of base that are only deep enough to produce a snug fit without removing more than half the wall base thickness.
 - 2. Inside Corners: Use straight pieces of maximum lengths possible. Form by cutting an inverted V-shaped notch in toe of wall base at the point where corner is formed. Shave back of base where necessary to produce a snug fit to substrate.

3.05 RESILIENT ACCESSORY INSTALLATION

- A. Resilient Molding Accessories: Butt to adjacent materials and tightly adhere to substrates throughout length of each piece. Install reducer strips at edges of floor coverings that would otherwise be exposed.

3.06 CLEANING AND PROTECTION

- A. Perform the following operations immediately after completing resilient product installation:
 - 1. Remove adhesive and other blemishes from exposed surfaces.
 - 2. Sweep and vacuum surfaces thoroughly.
 - 3. Damp-mop surfaces to remove marks and soil.
 - a. Do not wash surfaces until after time period recommended by manufacturer.
- B. Protect resilient products from mars, marks, indentations, and other damage from construction operations and placement of equipment and fixtures during remainder of construction period. Use protection methods recommended in writing by manufacturer.
 - 1. Apply protective floor polish to horizontal surfaces that are free from soil, visible adhesive, and surface blemishes if recommended in writing by manufacturer.
 - a. Use commercially available product acceptable to manufacturer.
 - b. Coordinate selection of floor polish with Owner's maintenance service.
 - 2. Cover products installed on horizontal surfaces with undyed, untreated building paper until Substantial Completion.
 - 3. Do not move heavy and sharp objects directly over surfaces. Place hardboard or plywood panels over flooring and under objects while they are being moved. Slide or roll objects over panels without moving panels.

END OF SECTION

SECTION 09680 - CARPET

PART 1 - GENERAL

1.01 RELATED DOCUMENTS

- A. Drawings and general provisions of Contract, including General and Supplementary Conditions and Division 1 Specification Sections, apply to this Section.

1.02 SUMMARY

- A. This Section includes carpet, installation, accessories, and cushion.
- B. The following sections contain requirements that relate to this Section:
 - 1. Division 9 Section "Resilient Floor Tile" for base materials, and installation.

1.03 SUBMITTALS

- A. Submit Manufacturer's Acknowledgement Letter in accordance with Division 1 section "Submittal Procedures.
- B. Submit the following in accordance with Conditions of Contract and Division 1 Specification Sections.
 - 1. Product data for each type of carpet material and installation accessory required. Submit written data on physical characteristics, durability, resistance to fading, and flame resistance characteristics.
 - 2. Samples for verification purposes in manufacturer's standard size, showing full range of color, texture, and pattern variations expected. Prepare samples from same material to be used for the Work. Submit the following:
 - a. 24-inch-square samples of each type of carpet material required.
 - b. 24-inch-long samples of each type exposed edge stripping and accessory item.

1.04 QUALITY ASSURANCE

- A. Carpet Surface Burning Characteristics: Provide carpet identical to that tested for the following fire performance characteristics, per test method indicated below, by UL or other testing and inspecting organizations acceptable to authorities having jurisdiction. Identify carpet with appropriate markings of applicable testing and inspecting organization.
 - 1. Test Method: DOC FF 1-70.
 - 2. Rating: Pass.

1.05 DELIVERY, STORAGE, AND HANDLING

- A. Deliver materials to project site in original factory wrappings and containers, labeled with identification of manufacturer, brand name, and lot number.
- B. Store materials in original undamaged packages and containers, inside well-ventilated area protected from weather, moisture, soilage, extreme temperatures, and humidity. Lay flat, blocked off ground. Maintain minimum temperature of 68 deg F (20 deg C) at least three (3) days prior to and during installation in area where materials are stored.

1.06 PROJECT CONDITIONS

- A. Substrate Conditions: No condensation within 48 hours on underside of 4-foot by 4-foot polyethylene sheet, fully taped at perimeter to substrate.

- B. Substrate Conditions: pH of nine (9) or less when substrate wetted with potable water and pHDrion paper applied.

1.07 EXTRA MATERIALS

- A. Deliver extra materials to Owner. Furnish extra materials matching products installed as described below, packaged with protective covering for storage and identified with labels describing contents.
 - 1. Carpet: Before installation begins, furnish quantity of full width for each type of material equal to five (5) percent of amount installed.

PART 2 - PRODUCTS

2.01 MANUFACTURERS

- A. Available Manufacturers: Subject to compliance with requirements, manufacturers offering products that may be incorporated in the Work include, but are not limited to, the following:
 - 1. Bigelow, (800) 334-7789
 - 2. Lees, (800) 523-5647
 - 3. Mannington, (800) 241-2262
 - 4. Shaw, (800) 257-7429

2.02 WOVEN CARPET DATA

- A. Carpet:
 - 1. Product: Philadelphia Commercial Carpet, Queen Collection, Immerse PL Meditate 87500.
 - 2. Style: P0187
 - 3. Fiber: 100% nylon.
 - 4. Width: 24" x 24".
 - 5. Face weight: 14.5 oz. per square yard
 - 6. Backing: Ecoworx

2.03 ACCESSORIES

- A. Carpet Edge Guard: Extruded or molded heavy-duty vinyl or rubber of size and profile indicated; minimum 2-inch-wide anchorage flange; manufacturer's standard colors.
- B. Seaming Cement: Hot-melt adhesive tape or similar product recommended by carpet manufacturer for taping seams and butting cut edges at backing to form secure seams and to prevent pile loss at seams.
- C. Carpet Adhesive: Water resistant and non-staining as recommended by carpet manufacturer to comply with flammability requirements for installed carpet.

PART 3 - EXECUTION

3.01 PREPARATION

- A. Clear away debris and scrape up cementitious deposits from concrete surfaces to receive carpet; apply sealer to prevent dusting.

- B. Patch holes and level to a smooth surface. If previous finish chemically stripped, re-seal concrete. Seal powdery or porous surfaces with sealer recommended by carpet manufacturer.
- C. Patch holes and cracks. Sand to level. Remove wax. Seal surface with sealer recommended by carpet manufacturer.
- D. Replace missing pieces of existing resilient flooring or patch to level. Cut out peaked sheet goods seams and fill with latex underlayment.
- E. Remove chemical finish on terrazzo; patch grout lines and cracks to level with latex underlayment.

3.02 INSTALLATION

- A. Comply with manufacturer's recommendations for seam locations and direction of carpet; maintain uniformity of carpet direction and lay of pile. At doorways, center seams under door in closed position; do not place seams perpendicular to door frame, in direction of traffic through doorway. Do not bridge building expansion joints with continuous carpet.
- B. Extend carpet under removable flanges and furnishings and into alcoves and closets of each space.
- C. Provide cutouts where required, and bind cut edges where not concealed by protective edge guards or overlapping flanges.
- D. Install carpet edge guard where edge of carpet is exposed; anchor guards to substrate.
- E. Install with pattern parallel to walls and borders.
- F. Install carpet by trimming edges, butting cuts with seaming cement, and taping and/or sewing seams to provide sufficient strength for stretching and continued stresses during life of carpet.
- G. Stretch carpet to provide smooth, ripple-free, taut, trim edges; secure to stripping and conceal behind edge of stripping. Use power stretcher where carpet length is greater than 20 feet.
- H. Fit sections of carpet prior to application of adhesive. Trim edges and butt cuts with seaming cement.
- I. Apply adhesive uniformly to substrate in accordance with manufacturer's instructions. Butt edges tight to form seams without gaps. Roll entire area lightly to eliminate air pockets and ensure uniform bond.

3.03 CLEANING

- A. Remove adhesive from carpet surface with manufacturer's recommended cleaning agent.
- B. Remove and dispose of debris and unusable scraps. Vacuum with commercial machine with face-beater element. Remove soil. Replace carpet where soil cannot be removed. Remove protruding face yarn.
- C. Vacuum carpet.

3.04 PROTECTION

- A. Provide final protection and maintain conditions, in a manner acceptable to manufacturer and installer, to ensure carpet is not damaged or deteriorated at time of Substantial Completion.

END OF SECTION

SECTION 09770 - FRP WALL PANELS

PART 1 - GENERAL

1.01 RELATED DOCUMENTS

- A. Drawings and general provisions of Contract, including General and Supplementary Conditions and Division 1 Specification Sections, apply to this Section.

1.02 SUMMARY

- A. Section includes FRP wall panels.
- B. Related Sections include:
 - 1. Division 9 Section "Ceramic Tile" for wall tile finishes.

1.03 DEFINITION

- A. FRP Wall Panels: Composite panel composed of a proprietary plastic (polymer) matrix reinforced with glass fibers and specifically recommended by the manufacturer for application to gypsum board and cementitious wall substrates.

1.04 SUBMITTALS

- A. Submit product data. Include construction details, material descriptions, fire-test-response characteristics, dimensions of individual components and profiles, and finishes for each FRP wall panel.
- B. Submit samples for verification. Submit 6-inch square samples for each type of FRP wall panels required.
- C. Submit maintenance data for each type of FRP wall panels to include in maintenance manuals.
 - 1. Include recommended methods and frequency of maintenance for maintaining optimum condition of FRP wall panels under anticipated use conditions. Include precautions against using cleaning materials and methods that may be detrimental to type of FRP wall panels.

1.05 QUALITY ASSURANCE

- A. Obtain all FRP wall panels of same type and color or finish from one source or producer.
- B. Provide FRP panels and adhesives with the following fire-test-response characteristics as determined by testing identical products applied with identical adhesives to substrates per test method indicated below by UL or another testing and inspecting agency acceptable to authorities having jurisdiction.
 - 1. Surface-Burning Characteristics: As follows, per ASTM E 84:
 - a. Flame Spread - Less than 200
 - b. Smoke Developed - Less than 450

1.06 DELIVERY, STORAGE AND HANDLING

- A. Store materials inside in original undamaged packaging, in a well ventilated area protected from weather, moisture, soiling, extreme temperatures and humidity. Maintain temperature in storage area above 60 deg F.

- B. Protect FRP wall panels from direct sunlight.

1.07 PROJECT CONDITIONS

- A. Do not deliver or install FRP wall panels until building is enclosed and weatherproof, wet work is complete and dry, and HVAC system is operating and maintaining temperature at 70 deg F for not less than 72 hours before beginning installation and for the remainder of the construction period.
- B. Provide continuous ventilation during installation and for not less than the time recommended by FRP wall panel manufacturer for full drying or curing.
- C. Verify actual locations of walls, columns, and other construction contiguous with FRP panels by field measurements before fabrication.

PART 2 - PRODUCTS

2.01 MANUFACTURERS

- A. Acceptable manufacturers/products (or approved alternate):
 - 1. Marlite "Standard FRP"

2.02 FIBERGLASS REINFORCED WALL PANELS

- A. Physical Characteristics:
 - 1. Face Sheet Thickness: 3/32-inch (.09375 inch).
 - 2. Flexural Strength: 17,000 psi (ASTM D 790).
 - 3. Tensile Strength: 8,000 psi (ASTM D 638).
 - 4. Barcol Hardness: 40 (ASTM D 2583).
 - 5. Impact Resistance: 7 ft. lb. per in. (ASTM D 256, Izod method).
 - 6. Water Absorption: 0.17 percent (ASTM D 570).
- B. Colors/texture: As shown on Drawings

2.03 ACCESSORIES:

- A. Moldings and Trim: PVC moldings by manufacturer, color to match panels.
- B. Adhesives: As recommended by manufacturer.
- C. Fasteners: As recommended by manufacturer.

PART 3 - EXECUTION

3.01 EXAMINATION

- A. Examine substrates and wall areas, with Installer present, for compliance with requirements for installation tolerances and other conditions affecting performance of work.
 - 1. Verify compatibility of FRP wall panel adhesive with and suitability of substrates, including compatibility with existing finishes or primers.
- B. Proceed with installation only after unsatisfactory conditions have been corrected.

3.02 PREPARATION

- A. Complete finishing operations, including painting, before installing FRP wall panels.

- B. Acclimatize FRP wall panels by removing them from packaging in the installation areas not less than 24 hours before installation.
- C. Clean substrate to remove dust, debris, and loose particles.

3.03 INSTALLATION

- A. Install FRP wall panels in accordance with manufacturers recommendations using adhesives, fasteners, and trim, required or recommended by the manufacturer.
 - 1. Cut and drill panels with carbide tipped saw blades or drill bits, or cut with snips.
 - 2. Do not use materials with chips, cracks, voids, stains, or other defects that might be visible in the finished Work.
- B. Seal base conditions with silicone sealant.
- C. Remove excess adhesive and clean FRP wall panels using methods and materials recommended in writing by manufacturer.

3.04 PROTECTION

- A. Protect FRP wall panel surfaces from damage as required until Substantial Completion.

END OF SECTION

SECTION 09912 – PAINTING

This section revised and reissued with Addendum 6. Interior epoxy paint added.

PART 1 - GENERAL

1.01 RELATED DOCUMENTS

- A. Drawings and general provisions of the Contract, including General and Supplementary Conditions and Division 1 Specification Sections, apply to this Section.

1.02 SUMMARY

- A. This Section includes surface preparation and field painting of exposed exterior and interior items and surfaces.
 - 1. Surface preparation, priming, and finish coats specified in this Section are in addition to shop priming and surface treatment specified in other Sections.
- B. Paint exposed surfaces, except where these Specifications indicate that the surface or material is not to be painted or is to remain natural. If an item or a surface is not specifically mentioned, paint the item or surface the same as similar adjacent materials or surfaces. If a color of finish is not indicated, Architect will select from standard colors and finishes available.
- C. Do not paint prefinished items, concealed surfaces, finished metal surfaces, operating parts, and labels.
 - 1. Prefinished items include the following factory-finished components:
 - a. Architectural woodwork.
 - b. Metal toilet enclosures.
 - c. Finished mechanical and electrical equipment.
 - d. Light fixtures.
 - e. Other prefinished items.
 - 2. Concealed surfaces include walls or ceilings in the following generally inaccessible spaces:
 - a. Furred areas.
 - b. Ceiling plenums.
 - c. Pipe spaces.
 - d. Duct shafts.
 - e. Other concealed surfaces.
 - 3. Finished metal surfaces include the following:
 - a. Anodized aluminum.
 - b. Stainless steel.
 - c. Chromium plate.
 - d. Copper and copper alloys.
 - e. Bronze and brass.
 - f. Other finished metal surfaces.
 - 4. Operating parts include moving parts of operating equipment and the following:
 - a. Valve and damper operators.

- b. Linkages.
 - c. Sensing devices.
 - d. Motor and fan shafts.
 - e. Other operating parts.
5. Do not paint over UL, FMG, or other code-required labels or equipment name, identification, performance rating, or nomenclature plates.
- D. Related Sections include the following:
- 1. Division 5 Section "Metal Fabrications" for shop priming ferrous metal.
 - 2. Division 8 Section "Steel Doors and Frames" for factory priming steel doors and frames.
 - 3. Division 9 Section "Gypsum Board Assemblies" for surface preparation of gypsum board.

1.03 DEFINITIONS

- A. Standard coating terms defined in ASTM D 16 apply to this Section.
- 1. Flat refers to a lusterless or matte finish with a gloss range below 15 when measured at an 85-degree meter.
 - 2. Eggshell refers to low-sheen finish with a gloss range between 20 and 35 when measured at a 60-degree meter.
 - 3. Semigloss refers to medium-sheen finish with a gloss range between 35 and 70 when measured at a 60-degree meter.
 - 4. Full gloss refers to high-sheen finish with a gloss range more than 70 when measured at a 60-degree meter.

1.04 SUBMITTALS

- A. Submit Manufacturer's Acknowledgement Letter. Follow Division 1 Section "Submittal Procedures."
- B. Submit product data for each paint system indicated. Include block fillers and primers.
- 1. Submit an inclusive list of required coating materials. Indicate each material and cross-reference specific coating, finish system, and application. Identify each material by manufacturer's catalog number and general classification.
 - 2. Submit manufacturer's technical information, including label analysis and instructions for handling, storing, and applying each coating material.

1.05 SAMPLES

- A. Submit samples for verification for each color and material to be applied, with texture to simulate actual conditions, on representative samples of the actual substrate.
- 1. Submit samples, defining each separate coat, including block fillers and primers. Use representative colors when preparing Samples for review. Resubmit until required sheen, color, and texture are achieved.
 - a. For each color, as shown on Drawings (e.g. P-1, P-2 etc.), 3 samples will be required. Provide 1 sample of the primary selection, plus 2 additional samples of alternate selections for that color.
 - b. Provide 2 copies of each sample.
 - c. Architect will furnish color selections.

2. Provide a list of materials and applications for each coat of each Sample. Label each Sample for location and application.
3. Submit samples for Architect's review of color. Provide stepped samples (draw down cards) on 8-1/2" x 11" card stock.

1.06 QUALITY ASSURANCE

- A. Applicator shall be a firm or individual experienced in applying paints and coatings similar in material, design, and extent to those indicated for this Project, whose work has resulted in applications with a record of successful in-service performance.
- B. Obtain block fillers and primers for each coating system from the same manufacturer as the finish coats.
- C. Provide a full-coat benchmark finish sample for each type of coating and substrate required. Comply with procedures specified in PDCA P5. Duplicate finish of approved sample Submittals.
 1. Architect will select one room or surface to represent surfaces and conditions for application of each type of coating and substrate.
 - a. Wall Surfaces: Provide samples on at least 100 sq. ft.
 - b. Small Areas and Items: Architect will designate items or areas required.
 2. Apply benchmark samples, according to requirements for the completed Work, after permanent lighting and other environmental services have been activated. Provide required sheen, color, and texture on each surface.
 - a. After finishes are accepted, Architect will use the room or surface to evaluate coating systems of a similar nature.
 3. Final approval of colors will be from benchmark samples.

1.07 DELIVERY, STORAGE, AND HANDLING

- A. Deliver materials to Project site in manufacturer's original, unopened packages and containers bearing manufacturer's name and label and the following information:
 1. Product name or title of material.
 2. Product description (generic classification or binder type).
 3. Manufacturer's stock number and date of manufacture.
 4. Contents by volume, for pigment and vehicle constituents.
 5. Thinning instructions.
 6. Application instructions.
 7. Color name and number.
 8. VOC content.
- B. Store materials not in use in tightly covered containers in a well-ventilated area at a minimum ambient temperature of 45 deg F. Maintain storage containers in a clean condition, free of foreign materials and residue.
 1. Protect from freezing. Keep storage area neat and orderly. Remove oily rags and waste daily.

1.08 PROJECT CONDITIONS

- A. Apply waterborne paints only when temperatures of surfaces to be painted and surrounding air are between 50 and 90 deg F.

- B. Apply solvent-thinned paints only when temperatures of surfaces to be painted and surrounding air are between 45 and 95 deg F.
- C. Do not apply paint in snow, rain, fog, or mist; or when relative humidity exceeds 85 percent; or at temperatures less than 5 deg F above the dew point; or to damp or wet surfaces.
 - 1. Painting may continue during inclement weather if surfaces and areas to be painted are enclosed and heated within temperature limits specified by manufacturer during application and drying periods.

1.09 EXTRA MATERIALS

- A. Furnish extra paint materials from the same production run as the materials applied. Package with protective covering for storage and identify with labels describing contents. Deliver extra materials to Owner.
 - 1. Provide two gallons of each color applied.

PART 2 - PRODUCTS

2.01 MANUFACTURERS

- A. Subject to compliance with requirements, products that may be incorporated into the Work include, but are not limited to, products listed in other Part 2 articles.
 - 1. Benjamin Moore & Co. (Benjamin Moore).
 - 2. ICI Paint Stores, Inc. (Dulux Paint).
 - 3. Kelly-Moore Paint Co. (Kelly-Moore).
 - 4. PPG Industries, Inc. (Pittsburgh Paints).
 - 5. Sherwin-Williams Co. (Sherwin-Williams).

2.02 PAINT MATERIALS, GENERAL

- A. Provide block fillers, primers, and finish-coat materials that are compatible with one another and with the substrates indicated under conditions of service and application, as demonstrated by manufacturer based on testing and field experience.
- B. Provide manufacturer's best-quality paint material of the various coating types specified that are factory formulated and recommended by manufacturer for application indicated. Paint-material containers not displaying manufacturer's product identification will not be acceptable.
 - 1. Use of manufacturer's proprietary product names to designate colors or materials is not intended to imply that products named are required to be used to the exclusion of equivalent products of other manufacturers. Furnish manufacturer's material data and certificates of performance for proposed substitutions.
- C. Colors shall be as selected by Architect from manufacturer's full range.

2.03 EXTERIOR PRIMERS

- A. Exterior Siding Primer: Factory-formulated alkali-resistant acrylic-latex primer for exterior application.
 - 1. Benjamin Moore; Moore's Acrylic Masonry Sealer No. 066: Applied at a dry film thickness of not less than 0.7 mils.
 - a. Use over exterior concrete and masonry substrates.

2. Benjamin Moore; Moore's Alkyd Masonry Sealer No. 077: Applied at a dry film thickness of not less than 2.7 mils.
 - a. Use over mineral-fiber-reinforced cement panels.
 3. Dulux Paint; 2000-1200 Dulux Professional Exterior 100 Percent Acrylic Latex Primer: Applied at a dry film thickness of not less than 1.6 mils.
 4. Kelly-Moore; 247 Chem-Guard Acrylic Masonry Primer: Applied at a dry film thickness of not less than 1.9 mils.
 5. Pittsburgh Paints; 6-603 SpeedHide Interior/Exterior Acrylic Latex Alkali Resistant Primer: Applied at a dry film thickness of not less than 1.5 mils.
 6. Sherwin-Williams; Loxon Exterior Masonry Acrylic Primer A24W300: Applied at a dry film thickness of not less than 3.0 mils.
 7. Sherwin-Williams; A-100 Latex Exterior Wood Primer B42W41: Applied at a dry film thickness of not less than 1.4 mils.
- B. Exterior Ferrous-Metal Primer: Factory-formulated rust-inhibitive metal primer for exterior application.
1. Benjamin Moore; Moore's IMC Alkyd Metal Primer No. M06: Applied at a dry film thickness of not less than 2.0 mils.
 2. Dulux Paint; 4160-XXXX Devguard Multi-Purpose Tank & Structural Primer. Applied at a dry film thickness of not less than 2.0 mils.
 3. Kelly-Moore; 1711 Kel-Guard Alkyd White Rust Inhibitive Primer: Applied at a dry film thickness of not less than 2.0 mils.
 4. Pittsburgh Paints; 90-712 Pitt-Tech One Pack Interior/Exterior Primer Finish DTM Industrial Enamel: Applied at a dry film thickness of not less than 3.0 mils.
 5. Sherwin-Williams; Kem Kromik Universal Metal Primer B50NZ6/B50WZ1: Applied at a dry film thickness of not less than 3.0 mils.
- C. Exterior Galvanized Metal Primer: Factory-formulated galvanized metal primer for exterior application.
1. Benjamin Moore; Moore's IMC Acrylic Metal Primer No. M04: Applied at a dry film thickness of not less than 2.0 mils.
 2. Dulux Paint:
 - a. Typical: 4020-XXXX Devflex DTM Flat Interior/Exterior Waterborne Primer & Finish: Applied at a dry film thickness of not less than 2.2 mils.
 - b. Under Alkyd Finishes: 4160-XXXX Devguard Multi-Purpose Tank & Structural Primer: Applied at a dry film thickness of not less than 2.0 mils.
 3. Kelly-Moore; 1722 Kel-Guard Acrylic Galvanized Iron Primer: Applied at a dry film thickness of not less than 1.8 mils.
 4. Pittsburgh Paints; 90-709 Pitt-Tech One Pack Interior/Exterior Primer/Finish DTM Industrial Enamel: Applied at a dry film thickness of not less than 3.0 mils.
 5. Sherwin-Williams; primer not required over this substrate.

2.04 INTERIOR PRIMERS

- A. Interior Gypsum Board Primer: Factory-formulated latex-based primer for interior application.
1. Benjamin Moore; Moorcraft Super Spec Latex Enamel Undercoater & Primer Sealer No. 253: Applied at a dry film thickness of not less than 1.2 mils.

2. Dulux Paint; 1000-1200 Dulux Ultra Basecoat Interior Latex Wall Primer: Applied at a dry film thickness of not less than 1.2 mils.
 3. Kelly-Moore; 971 Acry-Prime Interior Latex Primer/Sealer: Applied at a dry film thickness of not less than 1.6 mils.
 4. Pittsburgh Paints; 6-2 SpeedHide Interior Quick-Drying Latex Sealer: Applied at a dry film thickness of not less than 1.0 mil.
 5. Sherwin-Williams; PrepRite 200 Latex Wall Primer B28W200 Series: Applied at a dry film thickness of not less than 1.6 mils.
- B. Interior Ferrous-Metal Primer: Factory-formulated quick-drying rust-inhibitive alkyd-based metal primer.
1. Benjamin Moore; Moore's IMC Alkyd Metal Primer No. M06: Applied at a dry film thickness of not less than 2.0 mils.
 2. Dulux Paint; 4130-6130 Devshield Rust Penetrating Metal Primer: Applied at a dry film thickness of not less than 2.2 mils.
 3. Kelly-Moore; 1711 Kel-Guard Alkyd White Rust Inhibitive Primer: Applied at a dry film thickness of not less than 2.0 mils.
 4. Pittsburgh Paints; 90-709 Pitt-Tech One Pack Interior/Exterior Primer/Finish DTM Industrial Enamel: Applied at a dry film thickness of not less than 1.5 mils.
 5. Sherwin-Williams; Kem Kromik Universal Metal Primer B50NZ6/B50WZ1: Applied at a dry film thickness of not less than 3.0 mils.
- C. Interior Zinc-Coated Metal Primer: Factory-formulated galvanized metal primer.
1. Benjamin Moore; Moore's IMC Acrylic Metal Primer No. M04: Applied at a dry film thickness of not less than 2.0 mils.
 2. Dulux Paint; 4160-6130 Devguard Multi-Purpose Tank & Structural Primer: Applied at a dry film thickness of not less than 2.0 mils.
 3. Kelly-Moore; 1722 Kel-Guard Acrylic Galvanized Iron Primer: Applied at a dry film thickness of not less than 1.8 mils.
 4. Pittsburgh Paints; 90-709 Pitt-Tech One Pack Interior/Exterior Primer/Finish DTM Industrial Enamel: Applied at a dry film thickness of not less than 3.0 mils.
 5. Sherwin-Williams; Galvite HS B50WZ30: Applied at a dry film thickness of not less than 3.0 mils.

2.05 EXTERIOR FINISH COATS

- A. Exterior Semigloss Acrylic Enamel: Factory-formulated semigloss waterborne acrylic-latex enamel for exterior application.
1. Benjamin Moore; Moorcraft Super Spec Latex House & Trim Paint No. 170: Applied at a dry film thickness of not less than 1.1 mils.
 2. Dulux Paint; 2406-XXXX Dulux Professional Exterior 100 Percent Acrylic Semi-Gloss Finish applied at a dry film thickness of not less than 1.3 mils.
 3. Kelly-Moore; 1250 Acry-Lustre Exterior Semi-Gloss Acrylic Finish: Applied at a dry film thickness of not less than 1.6 mils.
 4. Pittsburgh Paints; 6-900 Series SpeedHide Exterior House & Trim Semi-Gloss Acrylic Latex Paint: Applied at a dry film thickness of not less than 1.5 mils.
 5. Sherwin-Williams; A-100 Latex Gloss A8 Series: Applied at a dry film thickness of not less than 1.3 mils.

2.06 INTERIOR FINISH COATS

- A. Interior Semigloss Acrylic Enamel: Factory-formulated semigloss acrylic-latex enamel for interior application.
 - 1. Benjamin Moore; Moorcraft Super Spec Latex Semi-Gloss Enamel No. 276: Applied at a dry film thickness of not less than 1.2 mils.
 - 2. Dulux Paint; 1406-XXXX Dulux Professional Acrylic Semi-Gloss Interior Wall & Trim Enamel: Applied at a dry film thickness of not less than 1.5 mils.
 - 3. Kelly-Moore; 1649 Acrylic-Latex Semi-Gloss Enamel: Applied at a dry film thickness of not less than 1.7 mils.
 - a. Use for a semigloss acrylic finish over interior concrete, stucco, masonry, concrete masonry units, gypsum board, plaster, hardboard, and zinc-coated metal.
 - 4. Kelly-Moore; 1685 Dura-Poxy Semi-Gloss Acrylic Enamel: Applied at a dry film thickness of not less than 1.5 mils.
 - a. Use for a semigloss finish over interior wood and ferrous metal.
 - 5. Pittsburgh Paints; 6-500 Series SpeedHide Interior Semi-Gloss Latex: Applied at a dry film thickness of not less than 1.0 mil.
 - 6. Sherwin-Williams; ProMar 200 Interior Latex Semi-Gloss Enamel B31W200 Series: Applied at a dry film thickness of not less than 1.3 mils.
- B. Interior Water Based Epoxy (Semi-Gloss Finish):
 - 1. ICI Paints; 4406 Tru-Glaze WB Water Based Epoxy, Applied at a dry film thickness of not less than 2.5 mils.
 - 2. Pittsburgh Paints; Pitt-Glaze 16-901/16-802 Acrylic Epoxy. Applied at a dry film thickness of not less than 2.5 mils.
 - 3. Sherwin-Williams; Water Based Catalyzed Epoxy, B70/B60V25. Applied at a dry film thickness of not less than 2.5 mils.

PART 3 - EXECUTION

3.01 EXAMINATION

- A. Examine substrates, areas, and conditions, with Applicator present, for compliance with requirements for paint application. Comply with procedures specified in PDCA P4.
 - 1. Proceed with paint application only after unsatisfactory conditions have been corrected and surfaces receiving paint are thoroughly dry.
 - 2. Start of painting will be construed as Applicator's acceptance of surfaces and conditions within a particular area.
- B. Coordination of Work: Review other Sections in which primers are provided to ensure compatibility of the total system for various substrates. On request, furnish information on characteristics of finish materials to ensure use of compatible primers.
 - 1. Notify Architect about anticipated problems when using the materials specified over substrates primed by others.

3.02 PREPARATION

- A. Remove hardware and hardware accessories, plates, machined surfaces, lighting fixtures, and similar items already installed that are not to be painted. If removal is

impractical or impossible because of size or weight of the item, provide surface-applied protection before surface preparation and painting.

1. After completing painting operations in each space or area, reinstall items removed using workers skilled in the trades involved.
- B. Before applying paint or other surface treatments, clean substrates of substances that could impair bond of the various coatings. Remove oil and grease before cleaning.
1. Schedule cleaning and painting so dust and other contaminants from the cleaning process will not fall on wet, newly painted surfaces.
- C. Clean and prepare surfaces to be painted according to manufacturer's written instructions for each particular substrate condition and as specified.
1. Provide barrier coats over incompatible primers or remove and reprime.
 2. Cementitious Materials: Prepare concrete, concrete unit masonry, cement plaster, and mineral-fiber-reinforced cement panel surfaces to be painted. Remove efflorescence, chalk, dust, dirt, grease, oils, and release agents. Roughen as required to remove glaze. If hardeners or sealers have been used to improve curing, use mechanical methods of surface preparation.
 - a. Use abrasive blast-cleaning methods if recommended by paint manufacturer.
 - b. Determine alkalinity and moisture content of surfaces by performing appropriate tests. If surfaces are sufficiently alkaline to cause the finish paint to blister and burn, correct this condition before application. Do not paint surfaces if moisture content exceeds that permitted in manufacturer's written instructions.
 - c. Clean concrete floors to be painted with a 5 percent solution of muriatic acid or other etching cleaner. Flush the floor with clean water to remove acid, neutralize with ammonia, rinse, allow to dry, and vacuum before painting.
 3. Ferrous Metals: Clean ungalvanized ferrous-metal surfaces that have not been shop coated; remove oil, grease, dirt, loose mill scale, and other foreign substances. Use solvent or mechanical cleaning methods that comply with SSPC's recommendations.
 - a. Blast steel surfaces clean as recommended by paint system manufacturer and according to SSPC-SP 10/NACE No. 2.
 - b. Treat bare and sandblasted or pickled clean metal with a metal treatment wash coat before priming.
 - c. Touch up bare areas and shop-applied prime coats that have been damaged. Wire-brush, clean with solvents recommended by paint manufacturer, and touch up with same primer as the shop coat.
 4. Galvanized Surfaces: Clean galvanized surfaces with nonpetroleum-based solvents so surface is free of oil and surface contaminants. Remove pretreatment from galvanized sheet metal fabricated from coil stock by mechanical methods.
- D. Material Preparation: Mix and prepare paint materials according to manufacturer's written instructions.
1. Maintain containers used in mixing and applying paint in a clean condition, free of foreign materials and residue.

2. Stir material before application to produce a mixture of uniform density. Stir as required during application. Do not stir surface film into material. If necessary, remove surface film and strain material before using.
 3. Use only thinners approved by paint manufacturer and only within recommended limits.
- E. Tint each undercoat a lighter shade to simplify identification of each coat when multiple coats of same material are applied. Tint undercoats to match the color of the finish coat, but provide sufficient differences in shade of undercoats to distinguish each separate coat.

3.03 APPLICATION

- A. Apply paint according to manufacturer's written instructions. Use applicators and techniques best suited for substrate and type of material being applied.
1. Paint colors, surface treatments, and finishes are indicated in the paint schedules.
 2. Do not paint over dirt, rust, scale, grease, moisture, scuffed surfaces, or conditions detrimental to formation of a durable paint film.
 3. Provide finish coats that are compatible with primers used.
 4. The term "exposed surfaces" includes areas visible when permanent or built-in fixtures, grilles, convactor covers, covers for finned-tube radiation, and similar components are in place. Extend coatings in these areas, as required, to maintain system integrity and provide desired protection.
 5. Paint surfaces behind movable equipment and furniture the same as similar exposed surfaces. Before final installation of equipment, paint surfaces behind permanently fixed equipment or furniture with prime coat only.
 6. Paint interior surfaces of ducts with a flat, nonspecular black paint where visible through registers or grilles.
 7. Paint back sides of access panels and removable or hinged covers to match exposed surfaces.
 8. Finish exterior doors on tops, bottoms, and side edges the same as exterior faces.
 9. Finish interior of wall and base cabinets and similar field-finished casework to match exterior.
 10. Sand lightly between each succeeding enamel or varnish coat.
- B. Scheduling Painting: Apply first coat to surfaces that have been cleaned, pretreated, or otherwise prepared for painting as soon as practicable after preparation and before subsequent surface deterioration.
1. The number of coats and film thickness required are the same regardless of application method. Do not apply succeeding coats until previous coat has cured as recommended by manufacturer. If sanding is required to produce a smooth, even surface according to manufacturer's written instructions, sand between applications.
 2. Omit primer over metal surfaces that have been shop primed and touchup painted.
 3. If undercoats, stains, or other conditions show through final coat of paint, apply additional coats until paint film is of uniform finish, color, and appearance. Give

special attention to ensure that edges, corners, crevices, welds, and exposed fasteners receive a dry film thickness equivalent to that of flat surfaces.

4. Allow sufficient time between successive coats to permit proper drying. Do not recoat surfaces until paint has dried to where it feels firm, and does not deform or feel sticky under moderate thumb pressure, and until application of another coat of paint does not cause undercoat to lift or lose adhesion.
- C. Application Procedures: Apply paints and coatings by brush, roller, spray, or other applicators according to manufacturer's written instructions.
1. Brushes: Use brushes best suited for type of material applied. Use brush of appropriate size for surface or item being painted.
 2. Rollers: Use rollers of carpet, velvet-back, or high-pile sheep's wool as recommended by manufacturer for material and texture required.
 3. Spray Equipment: Use airless spray equipment with orifice size as recommended by manufacturer for material and texture required.
- D. Minimum Coating Thickness: Apply paint materials no thinner than manufacturer's recommended spreading rate to achieve dry film thickness indicated. Provide total dry film thickness of the entire system as recommended by manufacturer.
- E. Mechanical and Electrical Work: Painting of mechanical and electrical work is limited to items exposed on exterior of building and exposed in occupied spaces.
- F. Mechanical items to be painted include, but are not limited to, the following:
1. Uninsulated metal piping.
 2. Uninsulated plastic piping.
 3. Pipe hangers and supports.
 4. Tanks that do not have factory-applied final finishes.
 5. Visible portions of internal surfaces of metal ducts, without liner, behind air inlets and outlets.
 6. Duct, equipment, and pipe insulation having "all-service jacket" or other paintable jacket material.
 7. Mechanical equipment that is indicated to have a factory-primed finish for field painting.
- G. Electrical items to be painted include, but are not limited to, the following:
1. Switchgear.
 2. Conduit, outlet boxes and electrical cabinets
 3. Panelboards.
 4. Electrical equipment that is indicated to have a factory-primed finish for field painting.
- H. Prime Coats: Before applying finish coats, apply a prime coat, as recommended by manufacturer, to material that is required to be painted or finished and that has not been prime coated by others. Recoat primed and sealed surfaces where evidence of suction spots or unsealed areas in first coat appears, to ensure a finish coat with no burn-through or other defects due to insufficient sealing.
- I. Pigmented (Opaque) Finishes: Completely cover surfaces as necessary to provide a smooth, opaque surface of uniform finish, color, appearance, and coverage. Cloudiness, spotting, holidays, laps, brush marks, runs, sags, ropiness, or other surface imperfections will not be acceptable.

- J. Transparent (Clear) Finishes: Use multiple coats to produce a glass-smooth surface film of even luster. Provide a finish free of laps, runs, cloudiness, color irregularity, brush marks, orange peel, nail holes, or other surface imperfections.
 - 1. Provide satin finish for final coats.
- K. Completed Work: Match approved samples for color, texture, and coverage. Remove, refinish, or repaint work not complying with requirements.

3.04 FIELD QUALITY CONTROL

- A. Owner reserves the right to invoke the following test procedure at any time and as often as Owner deems necessary during the period when paint is being applied:
 - 1. Owner will engage a qualified independent testing agency to sample paint material being used. Samples of material delivered to Project will be taken, identified, sealed, and certified in the presence of Contractor.
 - 2. Testing agency will perform appropriate tests for the following characteristics as required by Owner:
 - a. Quantitative material analysis.
 - b. Abrasion resistance.
 - c. Apparent reflectivity.
 - d. Flexibility.
 - e. Washability.
 - f. Absorption.
 - g. Accelerated weathering.
 - h. Dry opacity.
 - i. Accelerated yellowness.
 - j. Recoating.
 - k. Skinning.
 - l. Color retention.
 - m. Alkali and mildew resistance.
 - 3. Owner may direct Contractor to stop painting if test results show material being used does not comply with specified requirements. Contractor shall remove noncomplying paint from Project site, pay for testing, and repaint surfaces previously coated with the noncomplying paint. If necessary, Contractor may be required to remove noncomplying paint from previously painted surfaces if, on repainting with specified paint, the two coatings are incompatible.

3.05 CLEANING

- A. At the end of each workday, remove empty cans, rags, rubbish, and other discarded paint materials from Project site.
 - 1. After completing painting, clean glass and paint-spattered surfaces. Remove spattered paint by washing and scraping without scratching or damaging adjacent finished surfaces.

3.06 PROTECTION

- A. Protect work of other trades, whether being painted or not, against damage from painting. Correct damage by cleaning, repairing or replacing, and repainting, as approved by Architect.

- B. Provide "Wet Paint" signs to protect newly painted finishes. After completing painting operations, remove temporary protective wrappings provided by others to protect their work.
 - 1. After work of other trades is complete, touch up and restore damaged or defaced painted surfaces. Comply with procedures specified in PDCA P1.

3.07 EXTERIOR PAINT SCHEDULE

- A. Mineral-Fiber-Reinforced Cement Panels: Provide the following finish systems over exterior, mineral-fiber-reinforced cement panels:
 - 1. Flat Acrylic Finish: Two finish coats over a primer.
 - a. Primer: Exterior concrete and masonry primer.
 - b. Finish Coats: Exterior flat acrylic paint.
- B. Ferrous Metal: Provide the following finish systems over exterior ferrous metal. Primer is not required on shop-primed items.
 - 1. Semigloss Acrylic-Enamel Finish: Two finish coats over a rust-inhibitive primer.
 - a. Primer: Exterior ferrous-metal primer.
 - b. Finish Coats: Exterior semigloss acrylic enamel.
- C. Zinc-Coated Metal: Provide the following finish systems over exterior zinc-coated metal surfaces:
 - 1. Semigloss Acrylic-Enamel Finish: Two finish coats over a galvanized metal primer.
 - a. Primer: Exterior galvanized metal primer.
 - b. Finish Coats: Exterior semigloss acrylic enamel.

3.08 INTERIOR PAINT SCHEDULE

- A. Gypsum Board - provide semigloss acrylic finish over interior gypsum board surfaces - two finish coats over a primer.
 - 1. Primer: Interior gypsum board primer.
 - 2. Finish Coats: Interior semigloss acrylic enamel.
- B. Ferrous Metal - provide full-gloss alkyd-enamel finish - two finish coats over a primer.
 - 1. Primer: Interior ferrous-metal primer.
 - 2. Finish Coats: Interior full-gloss alkyd enamel for wood and metal surfaces.
- C. Zinc-Coated Metal - Provide full-gloss alkyd-enamel finish over interior zinc-coated metal surfaces - full-gloss alkyd-enamel finish - two finish coats over a primer.
 - 1. Primer: Interior zinc-coated metal primer.
 - 2. Finish Coats: Interior full-gloss alkyd enamel for wood and metal surfaces.
- D. Epoxy paint over gypsum board – gloss finish - two coats.
 - 1. Finish coats: Interior gloss epoxy paint.

END OF SECTION

SECTION 10161 – STAINLESS STEEL TOILET PARTITIONS

PART 1 - GENERAL

1.01 RELATED DOCUMENTS

- A. Drawings and general provisions of Contract, including General and Supplementary Conditions and Division 1 Specification Sections, apply to this Section.

1.02 SUMMARY

- A. Section includes manufactured stainless steel toilet compartments.
 - 1. Partition style: Floor anchored, overhead braced.
 - 2. Screen style: Wall hung.

1.03 RELATED SECTIONS

- A. Division 10 Section, "Toilet Accessories" for toilet paper holders, grab bars, purse shelves, etc.

1.04 SUBMITTALS

- A. Submit manufacturer's acknowledgement letter. Follow Division 1 Section "Submittal Procedures."
- B. Submit product data for materials, fabrication, and installation including catalog cuts of anchors, hardware, fastenings, and accessories.
- C. Submit shop drawings for fabrication and erection of toilet compartment assemblies not fully described by product drawings, templates, and instructions for installation of anchorage devices built into other work.

1.05 QUALITY ASSURANCE

- A. Take field measurements prior to preparation of shop drawings and fabrication, where possible, to ensure proper fitting of work. However, allow for adjustments where taking of field measurements before fabrication might delay work.
- B. Furnish inserts and anchorages which must be built into other work for installation of toilet compartments and related items. Coordinate delivery with other work to avoid delay.

PART 2 - PRODUCTS

2.01 MANUFACTURERS

- A. Manufacturer/Product: General Partitions Manufacturing Corp., Series 40, floor supported with headrail.

2.02 DOORS AND PANELS

- A. Provide materials which have been selected for surface flatness and smoothness. Exposed surfaces which exhibit pitting, seam marks, roller marks, stains, discolorations, telegraphing of core material, or other imperfections on finished units are not acceptable.

- B. Panel shall be double-wall construction, 1 inch thick, with two sheets of stainless steel, bonded together before attaching die drawn stainless steel molding on all four sides of panels.
 - 1. Mitered stainless steel reinforcements shall be fused to corners. Filler shall be General's Ribcore sound-deadening insulation.
- C. Doors shall be same construction as panels.

2.03 PILASTERS

- A. Pilasters shall be 1 1/4 inch thick with two sheets of Stainless Steel, bonded before attaching die drawn stainless steel molding to sides, and shall be same construction as panels. Pilasters shall be anchored to floor with heavy-gauge angle. Top of pilasters shall be securely braced with extruded aluminum headrail with integral crown loafer rail.
 - 1. Headrail shall be 1 7/8 inch x 1 5/32 inch x 1/16 inch with integral crown loafer rail, extruded aluminum heat-treated and anodized with necessary fittings.

2.04 HARDWARE AND FITTINGS

- A. Hardware shall be fabricated of heavy cast non-ferrous alloy, chrome-plated.
- B. Provide the following hardware:
 - 1. Concealed latch (No. 2000D)
 - 2. Coat hook (No. 6200D)
 - 3. Hinge brackets (No. 1250D)
 - 4. Door stop keeper (No. 2060D)
 - 5. Concealed hinge (No. 1000D). Shall work on opposing nylon cams under spring tension. Shall have top pivot pin, mounted within door having bearing points above and below hinge bracket.
- C. Wall connection brackets for panels and pilasters shall be high strength heavy chrome plated. Pilaster trim shall be 3 inch high, fabricated from .031 stainless steel. All hardware and fittings shall be secured with vandal-proof sex bolts or No. 14 screws of proper lengths.

2.05 FABRICATION

- A. Furnish standard doors, panels, screens, and pilasters fabricated for compartment system. Furnish units with cutouts, drilled holes, and internal reinforcement to receive partition-mounted hardware, accessories, and grab bars, as indicated.
- B. Unless otherwise indicated, furnish 24 inch wide in-swinging doors for ordinary toilet stalls and 32 inch wide (clear opening) out-swinging doors for stalls equipped for use by handicapped.

2.06 FINISH

- A. Satin finish

PART 3 - EXECUTION

3.01 INSTALLATION

- A. Comply with manufacturer's recommended procedures and installation sequence. Install compartment units rigid, straight, plumb, and level. Provide clearances of not more than 1/2 inch between pilasters and panels, and not more than 1 inch between

panels and walls. Secure panels to walls with not less than two stirrup brackets attached near top and bottom of panel. Locate wall brackets so that holes for wall anchorages occur in masonry or tile joints. Secure panels to pilasters with not less than two stirrup brackets located to align with stirrup brackets at wall. Secure panels in position with manufacturer's recommended anchoring devices.

- B. Overhead-Braced Compartments: Secure pilasters to floor and level, plumb, and tighten installation with devices furnished. Secure overhead brace to each pilaster with not less than two fasteners. Hang doors and adjust so that tops of doors are parallel with overhead brace when doors are in closed position.
- C. Screens: Attach with anchoring devices as recommended by manufacturer to suit supporting structure. Set units to provide support and to resist lateral impact.

3.02 ADJUST AND CLEAN

- A. Hardware Adjustment: Adjust and lubricate hardware for proper operation. Set hinges on in-swinging doors to hold open approximately 30 degrees from closed position when unlatched. Set hinges on out-swinging doors (and entrance swing doors) to return to fully closed position.
- B. Clean exposed surfaces of partition systems using materials and methods recommended by manufacturer, and provide protection as necessary to prevent damage during remainder of construction period.

END OF SECTION

SECTION 10350 - FLAGPOLES

PART 1 - GENERAL

1.01 RELATED DOCUMENTS

- A. Drawings and general provisions of the Contract, including General and Supplementary Conditions and Division 1 Specification Sections, apply to this Section.

1.02 SUMMARY

- A. Section includes
 - 1. Ground-set flagpole made from aluminum.
 - 2. Flags.
- B. Related Sections include the following:
 - 1. Division 3 Section "Cast-in-Place Concrete" for concrete footings for flagpoles.
 - 2. Division 7 Section "Joint Sealants" for elastomeric sealant filling the top of the foundation tube.

1.03 PERFORMANCE REQUIREMENTS

- A. Provide flagpole assemblies, including anchorages and supports, capable of withstanding the effects of wind loads, determined according to NAAMM FP 1001, "Guide Specifications for Design of Metal Flagpoles."
 - 1. Base flagpole design on nylon or cotton flags of maximum standard size suitable for use with flagpole or flag size indicated, whichever is more stringent.
 - 2. Basic Wind Speed: 90 mph; 3-second gust speed at 33 feet above ground.

1.04 SUBMITTALS

- A. Submit manufacturer's acknowledgement letter. Follow Division 1 Section "Submittal Procedures."
- B. Submit product data for each type of flagpole required. Indicate flag size recommended by manufacturer for flagpole height shown.
- C. Submit shop drawings. Include elevations and details showing general arrangement, jointing, fittings and accessories, grounding, and anchoring and supporting systems.
 - 1. Include details of foundation system for ground-set flagpoles.
- D. Submit structural calculations for flagpoles indicated to comply with design loads, include structural analysis data signed and sealed by the qualified professional engineer responsible for their preparation.
- E. Submit finish samples for verification for each finished material used for flagpoles and accessories.
- F. Submit qualification data for professional engineer.

1.05 QUALITY ASSURANCE

- A. Source Limitations:

1. Obtain each flagpole as a complete unit, including fittings, accessories, bases, and anchorage devices, from a single manufacturer.
2. Obtain flagpoles through one source from a single manufacturer.

1.06 DELIVERY, STORAGE, AND HANDLING

- A. Spiral wrap flagpoles with heavy paper and enclose in a hard fiber tube or other protective container.

PART 2 - PRODUCTS

2.01 MANUFACTURER/PRODUCT

- A. American Flagpole and Flag Co. "Estate Flagpole"
 1. Exposed height 25', overall length 27.5'.
 2. Base diameter 5", top diameter 3".
 3. Wall thickness: 0.156".
 4. Material: Alloy 6063-T6 aluminum tubing with uniform conical taper
 5. Finish: dark bronze anodized
 6. Truck: Cast aluminum stationary truck with pulley
 7. Halyard: 5/16 Inch nylon rope with six nylon snap hooks.
 8. Cleats: One 6-inch cast aluminum, each attached with two 5/16-inch stainless steel screws

2.02 FLAGPOLE CONSTRUCTION

- A. Construct flagpoles in one piece if possible. If more than one piece is necessary, comply with the following:
 1. Fabricate shop and field joints without using fasteners, screw collars, or lead caulking.
 2. For tapered flagpoles, provide flush hairline joints using self-aligning, snug-fitting, internal sleeves.
- B. Sleeve for Aluminum Flagpole: PVC pipe foundation sleeve, made to fit flagpole, for casting into concrete foundation.
 1. Provide flashing collar of same material and finish as flagpole.

2.03 FITTINGS

- A. Finial Ball: Manufacturer's standard gold anodized aluminum flush-seam ball.

2.04 MISCELLANEOUS MATERIALS

- A. Concrete: Comply with requirements in Division 3 Section "Cast-in-Place Concrete" for normal-weight, air-entrained, ready-mix concrete with a minimum 28-day compressive strength of 3000 psi.
- B. Sand: ASTM C 33, fine aggregate.
- C. Elastomeric Joint Sealant: Single-component urethane joint sealant complying with requirements in Division 7 Section "Joint Sealants" for Use NT (nontraffic) and for Use M, G, A, and, as applicable to joint substrates indicated, O joint substrates.
- D. Flags: Manufacturer's standard nylon in largest size recommended by manufacturer for flagpole height indicated. Provide one flag for each of the following entities:

1. United State of America.
2. State of Texas

2.05 FINISHES

- A. Comply with NAAMM's "Metal Finishes Manual for Architectural and Metal Products" for recommendations for applying and designating finishes.
- B. Aluminum: Finish designations prefixed by AA comply with the system established by the Aluminum Association for designating aluminum finishes.
 1. Anodic Coating: Architectural Class I, clear coating 0.018 mm or thicker) complying with AAMA 611.

PART 3 - EXECUTION

3.01 PREPARATION

- A. Prepare uncoated metal flagpoles that are set in foundation tubes by painting below-grade portions with a heavy coat of bituminous paint.
- B. Foundation Excavation: Excavate to neat clean lines in undisturbed soil. Remove loose soil and foreign matter from excavation and moisten earth before placing concrete.
- C. Provide forms where required due to unstable soil conditions and for perimeter of flagpole base at grade. Secure and brace forms and foundation tube, sleeve, or anchor bolts in position, to prevent displacement during concreting.
- D. Place concrete immediately after mixing. Compact concrete in place by using vibrators. Moist-cure exposed concrete for not less than seven days or use nonstaining curing compound.
- E. Trowel exposed concrete surfaces to a smooth, dense finish, free of trowel marks, and uniform in texture and appearance. Provide positive slope for water runoff to perimeter of concrete base.

3.02 FLAGPOLE INSTALLATION

- A. Install flagpoles where shown and according to Shop Drawings and manufacturer's written instructions.
- B. Foundation-Tube Installation: Install flagpole in foundation tube, seated on bottom plate between steel centering wedges. Plumb flagpole and install hardwood wedges to secure flagpole in place. Place and compact sand in foundation tube and remove hardwood wedges. Seal top of foundation tube with a 2-inch layer of elastomeric joint sealant and cover with flashing collar.

END OF SECTION

SECTION 10523 - FIRE EXTINGUISHERS, CABINETS AND ACCESSORIES

PART 1 - GENERAL

1.01 RELATED DOCUMENTS

- A. Drawings and general provisions of the Contract, including General and Supplementary Conditions and other Division 1 Specification Sections, apply to this Section.

1.02 WORK INCLUDED

- A. Fire extinguishers
- B. Brackets.
- C. Cabinets.

1.03 SHOP DRAWINGS AND PRODUCT DATA

- A. Submit manufacturer's product data for all items specified as a part of this Section, in accordance with Section 01340.
- B. Indicate profiles, sizes, connection details, size and type of fasteners and accessories. Indicate type of finish.

PART 2 - PRODUCTS

2.01 FIRE EXTINGUISHERS, DRY CHEMICAL

- A. Type: Multi-purpose dry chemical, type ABC, 10 lb., with UL rating of 4A-60B:C.
- B. Location as shown on Drawings, and as specified with fire extinguisher cabinets specified in this Section.
- C. Acceptable manufacturers/products
 1. Larsen's Manufacturing Co., Minneapolis, MN, "No. MP10."
 2. Modern Metal Products, Owatonna, MN, "Wing 10 HB"

2.02 FIRE EXTINGUISHER BRACKETS

- A. Furnish Larsen 846 or approved alternate.

2.03 FIRE EXTINGUISHER CABINETS

- A. Fully recessed, with 5/16" flat trim.
- B. Acceptable manufacturer/product Larsen Architectural Series. Solid door with engraved letters. #8 stainless steel.

PART 3 - EXECUTION

3.01 INSTALLATION

- A. Install all items in accordance with approved product data and manufacturer's recommendations.
- B. Install items square and level, accurately fitted and free from distortion and defects. Height as shown on drawings.

3.02 CERTIFICATION

- A. Fire extinguishers will bear certification meeting requirements of local fire department. Certification shall be dated within two weeks of date of Substantial Completion.

END OF SECTION

SECTION 10810 - TOILET ACCESSORIES

PART 1 - GENERAL

1.01 RELATED DOCUMENTS

- A. Drawings and general provisions of the Contract, including General and Supplementary Conditions and Division 1 Specification Sections, apply to this Section.

1.02 SUMMARY

- A. Section includes:
 - 1. Grab bars.
 - 2. Warm-air dryers.
- B. Related Sections include:
 - 1. Division 10 Section "Stainless Steel Toilet Partitions".

1.03 SUBMITTALS

- A. Submit manufacturer's acknowledgement letter. Follow Division 1 Section "Submittal Procedures."
- B. Submit product data. Include construction details, material descriptions and thicknesses, dimensions, profiles, fastening and mounting methods, specified options, and finishes for each type of accessory specified.
- C. Submit setting drawings for cutouts required in other work; include templates, substrate preparation instructions, and directions for preparing cutouts and installing anchoring devices.
- D. Submit maintenance data for accessories to include in maintenance manuals specified in Division 1. Provide lists of replacement parts and service recommendations.

1.04 QUALITY ASSURANCE

- A. Provide products of same manufacturer for each type of accessory unit and for units exposed to view in same areas, unless otherwise approved by Architect.
- B. Accessory requirements, including those for materials, finishes, dimensions, capacities, and performance, are established by specific products indicated in the Toilet Accessory Schedule in Part 2 of this Section.

1.05 COORDINATION

- A. Coordinate accessory locations with other work to prevent interference with clearances required for access by disabled persons, proper installation, adjustment, operation, cleaning, and servicing of accessories.
- B. Deliver inserts and anchoring devices set into concrete or masonry as required to prevent delaying the Work.

1.06 WARRANTY

- A. Special warranty specified in this Article shall not deprive Owner of other rights Owner may have under other provisions of the Contract Documents and shall be in addition to,

and run concurrent with, other warranties made by Contractor under requirements of the Contract Documents.

- B. Provide manufacturer's mirror warranty, which shall be a written warranty, executed by mirror manufacturer agreeing to replace mirrors that develop visible silver spoilage defects within minimum warranty period indicated.
 - 1. Minimum Warranty Period: 15 years from date of Substantial Completion.

PART 2 - PRODUCTS

2.01 MANUFACTURERS

- A. Design is based on named product in Part 2 Article "Toilet Accessory Schedule." Subject to compliance with requirements, provide named product or a comparable product by one of the following:
 - 1. Toilet and Bath Accessories:
 - a. American Specialties, Inc.
 - b. Bobrick Washroom Equipment, Inc.
 - c. Bradley Corporation.
 - 2. Infant-Care Products:
 - a. American Infant Care Products Inc.
 - b. American Specialties, Inc.
 - c. Koala Corporation.

2.02 MATERIALS

- A. Stainless Steel: ASTM A 666, Type 304, with No. 4 finish (satin), in 0.0312-inch minimum nominal thickness, unless otherwise indicated.
- B. Brass: ASTM B 19, leaded and unleaded flat products; ASTM B 16, rods, shapes, forgings, and flat products with finished edges; ASTM B 30, castings.
- C. Sheet Steel: ASTM A 366/A 366M, cold rolled, commercial quality, 0.0359-inch minimum nominal thickness; surface preparation and metal pretreatment as required for applied finish.
- D. Galvanized Steel Sheet: ASTM A 653/A 653M, G60.
- E. Chromium Plating: ASTM B 456, Service Condition Number SC 2 (moderate service), nickel plus chromium electrodeposited on base metal.
- F. Baked-Enamel Finish: Factory-applied, gloss-white, baked-acrylic-enamel coating.
- G. Mirror Glass: ASTM C 1036, Type I, Class 1, Quality q2, nominal 6.0 mm thick, with silvering, electroplated copper coating, and protective organic coating complying with FS DD-M-411.
- H. Galvanized Steel Mounting Devices: ASTM A 153/A 153M, hot-dip galvanized after fabrication.
- I. Fasteners: Screws, bolts, and other devices of same material as accessory unit, tamper and theft resistant when exposed, and of galvanized steel when concealed.

2.03 FABRICATION

- A. Maximum of one 1-1/2-inch diameter, unobtrusive stamped manufacturer logo, as approved by Architect, is permitted on exposed face of accessories. On interior surface

not exposed to view or back surface of each accessory, provide printed, waterproof label or stamped nameplate indicating manufacturer's name and product model number.

- B. Surface-Mounted Toilet Accessories: Unless otherwise indicated, fabricate units with tight seams and joints, and exposed edges rolled. Hang doors and access panels with continuous stainless-steel hinge. Provide concealed anchorage where possible.
- C. Recessed Toilet Accessories: Unless otherwise indicated, fabricate units of all-welded construction, without mitered corners. Hang doors and access panels with full-length, stainless-steel hinge. Provide anchorage that is fully concealed when unit is closed.
- D. Framed Glass-Mirror Units: Fabricate frames for glass-mirror units to accommodate glass edge protection material. Provide mirror backing and support system that permits rigid, tamper-resistant glass installation and prevents moisture accumulation.
 - 1. Provide galvanized steel backing sheet, not less than 0.034 inch and full mirror size, with nonabsorptive filler material. Corrugated cardboard is not an acceptable filler material.
- E. Mirror-Unit Hangers: Provide mirror-unit mounting system that permits rigid, tamper- and theft-resistant installation, at the Contractor's option, one of the following:
 - 1. One-piece, galvanized steel, wall-hanger device with spring-action locking mechanism to hold mirror unit in position with no exposed screws or bolts.
 - 2. Heavy-duty wall brackets of galvanized steel, equipped with concealed locking devices requiring a special tool to remove.
- F. Keys: Provide universal keys for internal access to accessories for servicing and resupplying. Provide minimum of 4 keys to Owner's representative.

2.04 TOILET ACCESSORY SCHEDULE

- A. Surface-mounted convertible paper towel dispenser and waste receptacle
 - 1. Basis of Design Product: Bobrick B-3949.
 - 2. Type-304 stainless steel with welded construction. Exposed surfaces shall have satin finish. Flange shall be drawn and beveled, one-piece, seamless construction.
 - 3. Door shall be secured to cabinet with a full-length stainless steel piano-hinge and equipped with a semi-concealed tumbler lock keyed like other Bobrick washroom accessories.
 - 4. Paper towel dispenser shall dispense 600 C-fold or 800 multifold paper towels.
 - 5. Removable waste receptacle shall be secured to cabinet with a tumbler lock, have front and side edges of bottom and all top edges hemmed for safe handling, and shall have a minimum capacity of 12-gallons.
- B. Surface-mounted toilet tissue dispenser and utility shelf
 - 1. Basis of Design Product: Bobrick B-2840
 - 2. Type-304 stainless steel with satin finish. Shelf shall have 1/2" return edges with front edge hemmed for safe handling.
 - 3. Spindles shall be chrome-plated plastic with heavy-duty internal spring and shall hold standard-core toilet tissue rolls up to 5-1/2" diameter (1800 sheets).
- C. Surface-mounted soap dispenser
 - 1. Basis of Design Product: Bobrick B-4112

2. Surface-mounted soap dispenser shall be type-304 stainless steel with satin-finish. Corrosion-resistant valve shall dispense commercially marketed all-purpose hand soaps. To prevent corrosion, use only chloride-free pH-neutral liquid soaps.
3. Valve shall be operable with one hand and with less than 5 pounds of force to comply with barrier-free accessibility guidelines, including Texas Accessibility Standards.
4. Front of soap dispenser shall have same degree of arc and match other Bobrick ConturaSeries accessories in the washroom. Radius on corners and edges of soap dispenser shall complement other Bobrick ConturaSeries washroom accessories.
5. Container body and back plate shall be epoxy-sealed to prevent warping and leakage. Soap dispenser shall have concealed, vandal-resistant mounting. Locked, hinged stainless steel lid for top filling shall require special key to open. Capacity shall be 40-fl oz (1.2-L).

D. Grab bar

1. Basis of Design Product: Bobrick B-5806.
2. Type-304 stainless steel with satin-finish. Grab bar shall have 18-gauge wall thickness and 1-1/4" outside diameter. Clearance between the grab bar and wall shall be 1-1/2".
3. Concealed mounting flanges shall be 1/8" thick stainless steel plate, 2" x 3-1/8" , and equipped with two screw holes for attachment to wall. Flange covers shall be 22-gauge stainless steel, 3-1/4" diameter, and shall snap over mounting flanges to conceal mounting screws and/or WingIt fasteners.
4. Ends of grab bar shall pass through concealed mounting flanges and be heliarc welded to form one structural unit. Grab bar shall comply with accessible design, including Texas Accessibility Standards, for structural strength.

E. Mirror Unit

1. Basis of Design Product: Bobrick B-165 Series
2. Mirror shall have a one-piece type-430 stainless steel channel frame, with 90° mitered corners. All exposed surfaces shall have bright polished finish.
3. Select float glass mirror shall be guaranteed for 15 years against silver spoilage. The back shall be protected by full-size, shock-absorbing, water-resistant, nonabrasive, polyethylene padding.
4. Galvanized steel back shall have integral horizontal hanging brackets located at top and bottom for mounting on concealed wall hanger to prevent the mirror from pulling away from the wall. Locking devices secure mirror to concealed wall hanger. Mirror shall be removable from the wall.
5. Size: As shown on Drawings

F. Mop and Broom Holder:

1. Basis of Design Product: Bobrick B-239.
2. Utility shelf with mop/broom holders and rag hooks shall be type-304 stainless steel with all-welded construction. Exposed surfaces shall have satin finish.
3. Shelf shall be 18 gauge, 8" deep with 3/4" return edges, and shall have front edge hemmed for safety.

G. Baby changing station

1. Basis of Design Product: Koala Kare Products KB110-SSRE Horizontal Recessed Mounted Stainless Steel Finish Baby Changing Station
2. Body shall have 18 gauge, type 304 satin stainless steel exterior finish with high-density grey polyethylene interior. Design of unit shall be recess-mounted.
3. Unit shall be equipped with a pneumatic cylinder for controlled opening and closing of bed. Bed shall be secured to back plate with a concealed, full-length steel-on-steel hinge.
4. Unit shall have Microban® antimicrobial embedded into plastic material. No hinge structure shall be exposed on interior or exterior surfaces.
5. Unit shall have 11-gauge steel mounting plates with mounting hardware included.
6. Unit shall conform to
 - a. ICC A117.1-2009 "Accessible and Usable Buildings and Facilities"
 - b. ASTM F 2285-04 "Standard Consumer Safety Performance Specification for Diaper Changing Tables for Commercial Use"
 - c. ANSI Z535.4 "Product Safety Signs and Labels"
 - d. ASTM G21 "Antifungal Standards"
 - e. Local code if more stringent installation requirements are applicable for barrier-free accessibility.
 - f. Unit shall comply with ADA regulations when properly installed.
7. Bed shall have smooth concave changing area with a nylon safety strap and two hooks for bags or purses. Unit shall have a built-in Liner Dispenser for use with 3-ply chemical free biodegradable sanitary liners, universal instruction graphics and safety messages in 6 languages.
8. Unit shall be backed by manufacturer's 5-year limited warranty on materials and workmanship and include a provision for replacement caused by vandalism. Unit shall be manufactured in the U.S.A.

PART 3 - EXECUTION

3.01 INSTALLATION

- A. Install accessories according to manufacturers' written instructions, using fasteners appropriate to substrate indicated and recommended by unit manufacturer. Install units level, plumb, and firmly anchored in locations and at heights indicated.
- B. Secure mirrors to walls in concealed, tamper-resistant manner with special hangers, toggle bolts, or screws. Set units level, plumb, and square at locations indicated, according to manufacturer's written instructions for substrate indicated.
- C. Install grab bars to withstand a downward load of at least 250 lbf, when tested according to method in ASTM F 446.

3.02 ADJUSTING AND CLEANING

- A. Adjust accessories for unencumbered, smooth operation and verify that mechanisms function properly. Replace damaged or defective items.
- B. Remove temporary labels and protective coatings.

- C. Clean and polish exposed surfaces according to manufacturer's written recommendations.

END OF SECTION

SECTION 11022 – LOCK BOXES

PART 1 - GENERAL

1.01 RELATED DOCUMENTS

- A. Drawings and general provisions of the Contract, including General and Supplementary Conditions and Division 1 Specification Sections, apply to this Section.

1.02 SUMMARY

- A. Section includes fire-rated, high security industrial/governmental key boxes.

1.03 QUALITY ASSURANCE

- A. Products shall be U.L. Listed.

PART 2 - PRODUCTS

2.01 MANUFACTURERS

- A. Subject to compliance with requirements, provide products from Knox Company, 1601 W. Deer Valley Road, Phoenix, AZ 85027, 800-552-5669
 - 1. Product: Knox-Box 3200 Series, recessed mount with face flange, 7" x 7", 3" depth, with hinged door.

2.02 MATERIALS

- A. Lock shall be U.L. listed, with double-action rotating tumblers and hardened steel pins accessed by a biased cut key.
- B. Color: Dark Bronze

PART 3 - EXECUTION

3.01 INSTALLATION

- A. Verify and coordinate location(s) with local fire department. Request site visit by fire department official if required.
- B. Install key box assemblies complete with doors, frames, and accessories and according to requirements of fire-rated vault door assemblies' UL listing.
- C. Set key box frames accurately in position; plumbed, aligned, and braced securely until permanent anchors are set. After wall construction is complete, remove temporary braces and spreaders, leaving surfaces smooth and undamaged.
- D. Adjust door hardware and operating mechanism to function smoothly, and lubricate as recommended by manufacturer.

END OF SECTION

SECTION 12481 - ENTRANCE FLOOR MATS AND FRAMES

PART 1 - GENERAL

1.01 RELATED DOCUMENTS

- A. Drawings and general provisions of the Contract, including General and Supplementary Conditions and Division 1 Specification Sections, apply to this Section.

1.02 SUMMARY

- A. This section includes floor mats and frame assemblies

1.03 REFERENCES

- A. American Society for Testing and Materials (ASTM)
- B. The Aluminum Association
- C. The Carpet and Rug Institute (CRI)
- D. The National Floor Safety Institute (NFSI)

1.04 SUBMITTALS

- A. Submit the following in accordance with conditions of contract and Division 1 section "Submittals".
- B. Submit product data for each type of floor mat and frame specified including manufacturer's specifications and installation instructions.
- C. Submit shop drawings in sufficient detail showing layout of mat and frame specified including details indicating construction relative to materials, direction of traffic, spline locations, profiles, anchors and accessories.
- D. Submit samples for verification purposes. Submit an assembled section of floor mat and frame members with selected tread insert showing each type of color for exposed floor mat, frame and accessories required.
- E. Submit maintenance data in the form of manufacturer's printed instructions for cleaning and maintaining floor mats.

1.05 QUALITY ASSURANCE

- A. Flammability shall be in compliance with ASTM E648, Class 1, Critical Radiant Flux, minimum 0.45 watts/m².
- B. Slip resistance shall be in accordance with ASTM D-2047-96, Coefficient of Friction, minimum 0.60 for accessible routes.
- C. Standard rolling load performance is 350 lb./wheel with larger loading requirements as specified (load applied to a solid 5" x 2" wide polyurethane wheel, 1000 passes without damage).
- D. Obtain floor mats and frames from one source of a single manufacturer.
- E. Utilize superior structural aluminum alloy 6063-T6 for rail connectors.

1.06 DELIVERY, STORAGE AND HANDLING

- A. Deliver materials to the project site ready for use and fabricated in as large sections and

assemblies as practical, in unopened original factory packaging clearly labeled to identify manufacturer.

1.07 PROJECT CONDITIONS

- A. Check actual openings for mats by accurate field measurements before fabrication. Record actual measurements on final shop drawings. Coordinate fabrication schedule with construction progress to avoid delay of work.
- B. For recess application coordinate frame installation with concrete construction to ensure recess and frame anchorage are accurate and that the base is level and flat. Defer frame installation until building enclosure is complete and related interior finish work is in progress.

PART 2 - PRODUCTS

2.01 ACCEPTABLE MANUFACTURERS

- A. Drawings and specifications are based on manufacturer's literature from Construction Specialties, Inc. unless otherwise indicated. Other manufacturers must comply with the minimum levels of material and detailing indicated on the drawings and specified herein.

2.02 MATERIALS

- A. Aluminum - ASTM B 221, alloys 6063-T5, 6063-T6 for extrusions.
- B. Architectural Bronze - ASTM B 455, copper/zinc alloy C38500 for extrusions.
- C. Regrind PETG/Polyurethane extrusion.
- D. Flexible EPDM extrusions.
- E. Tread insert options - refer to section below.

2.03 FLOOR MATS

- A. Model and Description - M1 Pedimat
 1. Exposed hinge rail connectors shall be extruded 6063-T6 aluminum complete with perforations for drainage.
 2. Tread rails shall be manufactured from high-impact Regrind PET-G complete with co-extruded soft-durometer cushions.
 3. Overall depth without frame is 7/16" (11.1 mm).
- B. Supplied in mill (standard) or one of 9 optional colors as offered by manufacturer. (Call factory for custom colors.) Choose from anodized or heavy-duty powder coat finish.

2.04 MAT FRAMES

- A. TA – Surface Mounted Aluminum Frame shall be a 1 5/8"(38.1mm) wide 6105-T5 aluminum alloy and permanently positions mat for surface mounted applications.
 1. Frame finish: anodized, mill finish
- B. THFR- Threshold Frame shall be supplied in 6063-T6 aluminum alloy. For surface/recess installations to provide a flush transition from the entryway door threshold to the mat surface. The frame does not require a leveling screed.
 1. Frame finish: anodized

2.05 TREAD INSERT OPTIONS

- A. HD – MonoTuft HD™ Carpet shall meet CRI standard for good indoor air quality. Fibers

shall include a minimum of 100, 12 mil monofilament fibers per square inch.

1. Color shall be as selected from manufacturer's standards.
2. Carpet fiber and monofilament shall be fusion-bonded to a rigid two-ply backing to prevent fraying and supplied in continuous splice-free lengths.
3. Anti-static carpet fibers shall contain antimicrobial additive and be treated with Scotchgard® to reduce soiling. Carpet weight shall be 33-oz./yd².

PART 3 - EXECUTION

3.01 EXAMINATION

- A. Examine areas and conditions under which work is to be performed and identify conditions detrimental to proper or timely completion.
 1. Do not proceed until unsatisfactory conditions have been corrected.

3.02 PREPARATION

- A. Manufacturer shall offer assistance and guidance to provide a template of irregular shaped mat assemblies to ensure a proper installation.

3.03 INSTALLATION

- A. Install the work of this section in strict accordance with the manufacturer's recommendations.
- B. Set mat at height recommended by manufacturer for most effective cleaning action.
- C. Coordinate top of mat surface with bottom of doors that swing across to provide ample clearance between door and mat.

3.04 CLEANING

- A. Instruct the Owner that it is important to the life cycle of the entrance mat that a maintenance schedule be developed which includes regular vacuuming and extraction that correctly matches the amount of traffic the mat incurs.

3.05 PROTECTION

- A. After completing required frame installation and concrete work, provide temporary filler of plywood or fiberboard in recess, and cover frames with plywood protective flooring. Maintain protection until construction traffic has ended and project is near time of substantial completion.
- B. Defer installation of floor mats until time of substantial completion of project.

END OF SECTION

SECTION 12494 - ROLLER SHADES

This section issued with Addendum 6.

PART 1 - GENERAL

1.01 RELATED DOCUMENTS

- A. Drawings and general provisions of the Contract, including General and Supplementary Conditions and Division 1 Specification Sections, apply to this Section.

1.02 SECTION INCLUDES

- A. Room darkening roller shades.

1.03 RELATED SECTIONS

- A. Division 6 section "Rough Carpentry": Wood blocking and grounds for mounting roller shades and accessories.
- B. Division 9 section "Gypsum Board Assemblies": Coordination with gypsum board assemblies for installation of shade pockets, closures and related accessories.

1.04 REFERENCES

- A. ASTM G 21 - Standard Practice for Determining Resistance of Synthetic Polymeric Materials to Fungi.
- B. NFPA 701 - Fire Tests for Flame-Resistant Textiles and Films.

1.05 SUBMITTALS

- A. Submit under provisions of Section 01300.
- B. Submit manufacturer's data sheets on each product to be used, including:
 - 1. Preparation instructions and recommendations.
 - 2. Styles, material descriptions, dimensions of individual components, profiles, features, finishes and operating instructions.
 - 3. Storage and handling requirements and recommendations.
 - 4. Mounting details and installation methods.
- C. Submit window treatment schedule for all roller shades. Use same room designations as indicated on the Drawings and include opening sizes and key to typical mounting details.
- D. Submit verification samples for each finish product specified, one complete set of shade components, unassembled, demonstrating compliance with specified requirements. Shadecloth sample and aluminum finish sample as selected. Mark face of material to indicate interior faces.
- E. Submit maintenance data, including methods for maintaining roller shades, precautions regarding cleaning materials and methods, instructions for operating hardware and controls.

1.06 QUALITY ASSURANCE

- A. Obtain roller shades through one source from a single manufacturer with a minimum of twenty years experience in manufacturing products comparable to those specified in this section.
- B. Installer shall be trained and certified by the manufacturer with a minimum of ten years experience in installing products comparable to those specified in this section.
- C. Fire-Test-Response Characteristics: Passes NFPA 701 small and large-scale vertical burn. Materials tested shall be identical to products proposed for use.
- D. Anti-Microbial Characteristics: 'No Growth' per ASTM G 21 results for fungi ATCC9642, ATCC 9644, ATCC9645.

1.07 DELIVERY, STORAGE, AND HANDLING

- A. Deliver shades in factory-labeled packages, marked with manufacturer and product name, fire-test-response characteristics, and location of installation using same room designations indicated on Drawings and in the Window Treatment Schedule.

1.08 PROJECT CONDITIONS

- A. Install roller shades after finish work including painting is complete and ambient temperature and humidity conditions are maintained at the levels indicated for Project when occupied for its intended use.

1.09 WARRANTY

- A. Roller Shade Hardware and Chain Warranty: Manufacturer's standard non-depreciating twenty-five year limited warranty.
- B. Roller Shade Installation: One year from date of Substantial Completion, not including scaffolding, lifts or other means to reach inaccessible areas.

PART 2 - PRODUCTS

2.01 MANUFACTURERS

- A. Acceptable Manufacturer: MechoShade Systems, Inc., which is located at: 42-03 35th St.; Long Island City, NY 11101; Tel: 718-729-2020; Fax: 718-729-2941; Email: angela.gratereaux@mechoshade.com; Web: www.mechoshade.com
- B. Requests for substitutions will be considered in accordance with provisions of Section 01600.

2.02 ROLLER SHADE TYPES

- A. Manually Operated Shades:
 - 1. Mounting: Surface mounted.
 - 2. Configuration: Single blackout shadecloth.
 - 3. Blackout Shadecloths:
 - a. Fabric: Selected from manufacturer's standard fabrics.
 - b. Color: Selected from manufacturer's standard colors.

2.03 SHADE BAND

- A. Shade Bands: Construction of shade band includes the fabric, the hem weight, hem-pocket, shade roller tube, and the attachment of the shade band to the roller tube. Sewn hems and open hem pockets are not acceptable.
 - 1. Hem Pockets and Hem Weights: Fabric hem pocket with RF-welded seams (including welded ends) and concealed hem weights. Hem weights shall be of appropriate size and weight for shade band. Hem weight shall be continuous inside a sealed hem pocket. Hem pocket construction and hem weights shall be similar, for all shades within one room.
 - 2. Shade Band and Shade Roller Attachment:
 - a. Use extruded aluminum shade roller tube of a diameter and wall thickness required to support shade fabric without excessive deflection. Roller tubes less than 1.55 inch (39.37 mm) in diameter for manual shades, and less than 2.55 inches (64.77 mm) for motorize shades are not acceptable.
 - b. Provide for positive mechanical engagement with drive / brake mechanism.
 - c. Provide for positive mechanical attachment of shade band to roller tube; shade band shall be made removable / replaceable with a "snap-on" snap-off" spline mounting, without having to remove shade roller from shade brackets.
 - d. Mounting spline shall not require use of adhesives, adhesive tapes, staples, and/or rivets.
 - e. Any method of attaching shade band to roller tube that requires the use of: adhesive, adhesive tapes, staples, and/or rivets are not acceptable.

2.04 SHADE FABRICATION

- A. Fabricate units to completely fill existing openings from head to sill and jamb-to-jamb, unless specifically indicated otherwise.
- B. Fabricate shadecloth to hang flat without buckling or distortion. Fabricate with heat-sealed trimmed edges to hang straight without curling or raveling. Fabricate unguided shadecloth to roll true and straight without shifting sideways more than 1/8 inch (3.18 mm) in either direction per 8 feet (2438 mm) of shade height due to warp distortion or weave design.
 - 1. Fabricate hem with exposed blackout hembar with light seal.
- C. Provide battens in standard shades as required to assure proper tracking and uniform rolling of the shadebands. Contractor shall be responsible for assuring the width-to-height (W:H) ratios shall not exceed manufacturer's standards or, in absence of such standards, shall be responsible for establishing appropriate standards to assure proper tracking and rolling of the shadecloth within specified standards. Battens shall be roll-formed stainless steel or tempered steel, as required.
- D. For railroaded shadebands, provide seams in railroaded multi-width shadebands as required to meet size requirements and in accordance with seam alignment as acceptable to Architect. Seams shall be properly located. Furnish battens in place of plain seams when the width, height, or weight of the shade exceeds manufacturer's standards. In absence of such standards, assure proper use of seams or battens as required to, and assure the proper tracking of the railroaded multi-width shadebands.

- E. Provide battens for railroaded shades when width-to-height (W:H) ratios meet or exceed manufacturer's standards. In absence of manufacturer's standards, be responsible for proper use and placement of battens to assure proper tracking and roll of shadebands.
- F. Blackout shadebands, when used in side channels, shall have horizontally mounted, roll-formed stainless steel or tempered-steel battens not more than 3 feet (115 mm) on center extending fully into the side channels. Battens shall be concealed in a integrally-colored fabric to match the inside and outside colors of the shadeband, in accordance with manufacturer's published standards for spacing and requirements.
 - 1. Battens shall be roll formed of stainless steel or tempered steel and concave to match the contour of the roller tube.
 - 2. Batten pockets shall be self-colored fabric front and back RF welded into the shadecloth. A self-color opaque liner shall be provided front and back to eliminate any see through of the batten pocket that shall not exceed 1-1/2 inches (38.1 mm) high and be totally opaque. A see-through moire effect, which occurs with multiple layers of transparent fabrics, shall not be acceptable.

2.05 COMPONENTS

- A. Access and Material Requirements:
 - 1. Provide shade hardware allowing for the removal of shade roller tube from brackets without removing hardware from opening and without requiring end or center supports to be removed.
 - 2. Provide shade hardware that allows for removal and re-mounting of the shade bands without having to remove the shade tube, drive or operating support brackets.
 - 3. Use only Delrin engineered plastics by DuPont for all plastic components of shade hardware. Styrene based plastics, and /or polyester, or reinforced polyester will not be acceptable.
- B. Manual Operated Chain Drive Hardware and Brackets:
 - 1. Provide for universal, regular and offset drive capacity, allowing drive chain to fall at front, rear or non-offset for all shade drive end brackets. Universal offset shall be adjustable for future change.
 - 2. Provide hardware capable for installation of a removable fascia, for both regular and/or reverse roll, which shall be installed without exposed fastening devices of any kind.
 - 3. Provide shade hardware system that allows for removable regular and/or reverse roll fascias to be mounted continuously across two or more shade bands without requiring exposed fasteners of any kind.
 - 4. Provide shade hardware system that allows for operation of multiple shade bands (multi-banded shades) by a single chain operator, subject to manufacturer's design criteria. Connectors shall be offset to assure alignment from the first to the last shade band.
 - 5. Provide shade hardware system that allows multi-banded manually operated shades to be capable of smooth operation when the axis is offset a maximum of 6 degrees on each side of the plane perpendicular to the radial line of the curve, for a 12 degrees total offset.
 - 6. Provide positive mechanical engagement of drive mechanism to shade roller tube. Friction fit connectors for drive mechanism connection to shade roller tube are not acceptable

7. Provide shade hardware constructed of minimum 1/8-inch (3.18 mm) thick plated steel or heavier as required to support 150 percent of the full weight of each shade.
8. Drive Bracket / Brake Assembly:
 - a. MechoShade Drive Bracket model M5 shall be fully integrated with all MechoShade accessories, including, but not limited to: SnapLoc fascia, room darkening side / sill channels, center supports and connectors for multi-banded shades.
 - b. M5 drive sprocket and brake assembly shall rotate and be supported on a welded 3/8 inch (9.525 mm) steel pin.
 - c. The brake shall be an over-running clutch design which disengages to 90 percent during the raising and lowering of a shade. The brake shall withstand a pull force of 50 lbs. (22 kg) in the stopped position.
 - d. The braking mechanism shall be applied to an oil-impregnated hub on to which the brake system is mounted. The oil impregnated hub design includes an articulated brake assembly, which assures a smooth, non-jerky operation in raising and lowering the shades. The assembly shall be permanently lubricated. Products that require externally applied lubrication and or not permanently lubricated are not acceptable.
 - e. The entire M5 assembly shall be fully mounted on the steel support bracket, and fully independent of the shade tube assembly, which may be removed and reinstalled without effecting the roller shade limit adjustments.
 - f. Drive Chain: #10 qualified stainless steel chain rated to 90 lb. (41 kg) minimum breaking strength. Nickel plate chain shall not be accepted.

PART 3 - EXECUTION

3.01 EXAMINATION

- A. Do not begin installation until substrates have been properly prepared.
- B. If substrate preparation is the responsibility of another installer, notify Architect of unsatisfactory preparation before proceeding.

3.02 PREPARATION

- A. Clean surfaces thoroughly prior to installation.
- B. Prepare surfaces using the methods recommended by the manufacturer for achieving the best result for the substrate under the project conditions.

3.03 INSTALLATION

- A. Install roller shades level, plumb, square, and true according to manufacturer's written instructions, and located so shade band is not closer than 2 inches (50 mm) to interior face of glass. Allow proper clearances for window operation hardware.
- B. Adjust and balance roller shades to operate smoothly, easily, safely, and free from binding or malfunction throughout entire operational range.
- C. Clean roller shade surfaces after installation, according to manufacturer's written instructions.

- D. Engage Installer to train Owner's maintenance personnel to adjust, operate and maintain roller shade systems.

3.04 PROTECTION

- A. Protect installed products until completion of project.
- B. Touch-up, repair or replace damaged products before Substantial Completion.

END OF SECTION

SECTION 220500 – COMMON WORK RESULTS FOR PLUMBING

PART 1 - GENERAL

1.01 RELATED DOCUMENTS

- A. Drawings and general provisions of the Contract, including General and Supplementary Conditions and Division 01 Specification Sections, apply to this Section.

1.02 SUMMARY

- A. This Section includes the following:
 1. Piping materials and installation instructions common to most piping systems.
 2. Transition fittings.
 3. Dielectric fittings.
 4. Mechanical sleeve seals.
 5. Sleeves.
 6. Escutcheons.
 7. Grout.
 8. Plumbing demolition.
 9. Equipment installation requirements common to equipment sections.
 10. Painting and finishing.
 11. Concrete bases.
 12. Supports and anchorages.

1.03 DEFINITIONS

- A. Finished Spaces: Spaces other than mechanical and electrical equipment rooms, furred spaces, pipe chases, unheated spaces immediately below roof, spaces above ceilings, unexcavated spaces, crawlspaces, and tunnels.
- B. Exposed, Interior Installations: Exposed to view indoors. Examples include finished occupied spaces and mechanical equipment rooms.
- C. Exposed, Exterior Installations: Exposed to view outdoors or subject to outdoor ambient temperatures and weather conditions. Examples include rooftop locations.
- D. Concealed, Interior Installations: Concealed from view and protected from physical contact by building occupants. Examples include above ceilings and in chases.
- E. Concealed, Exterior Installations: Concealed from view and protected from weather conditions and physical contact by building occupants but subject to outdoor ambient temperatures. Examples include installations within unheated shelters.
- F. The following are industry abbreviations for plastic materials:
 1. ABS: Acrylonitrile-butadiene-styrene plastic.
 2. CPVC: Chlorinated polyvinyl chloride plastic.
 3. PE: Polyethylene plastic.
 4. PVC: Polyvinyl chloride plastic.
- G. The following are industry abbreviations for rubber materials:

1. EPDM: Ethylene-propylene-diene terpolymer rubber.
2. NBR: Acrylonitrile-butadiene rubber.

1.04 SUBMITTALS

- A. Product Data: For the following:
 1. Transition fittings.
 2. Dielectric fittings.
 3. Mechanical sleeve seals.
 4. Escutcheons.
- B. Retain below if procedures for welder certification are retained in "Quality Assurance" Article.
- C. Welding certificates.

1.05 QUALITY ASSURANCE

- A. Steel Support Welding: Qualify processes and operators according to AWS D1.1, "Structural Welding Code--Steel."
- B. Steel Pipe Welding: Qualify processes and operators according to ASME Boiler and Pressure Vessel Code: Section IX, "Welding and Brazing Qualifications."
 1. Comply with provisions in ASME B31 Series, "Code for Pressure Piping."
 2. Certify that each welder has passed AWS qualification tests for welding processes involved and that certification is current.
- C. Electrical Characteristics for Plumbing Equipment: Equipment of higher electrical characteristics may be furnished provided such proposed equipment is approved in writing and connecting electrical services, circuit breakers, and conduit sizes are appropriately modified. If minimum energy ratings or efficiencies are specified, equipment shall comply with requirements.

1.06 DELIVERY, STORAGE, AND HANDLING

- A. Deliver pipes and tubes with factory-applied end caps. Maintain end caps through shipping, storage, and handling to prevent pipe end damage and to prevent entrance of dirt, debris, and moisture.
- B. Store plastic pipes protected from direct sunlight. Support to prevent sagging and bending.

1.07 COORDINATION

- A. Arrange for pipe spaces, chases, slots, and openings in building structure during progress of construction, to allow for plumbing installations.
- B. Coordinate installation of required supporting devices and set sleeves in poured-in-place concrete and other structural components as they are constructed.
- C. Coordinate requirements for access panels and doors for plumbing items requiring access that are concealed behind finished surfaces. Access panels and doors are specified in Division 08 Section "Access Doors and Frames."

PART 2 - PRODUCTS

2.01 MANUFACTURERS

- A. In other Part 2 articles where subparagraph titles below introduce lists, the following requirements apply for product selection:

1. Available Manufacturers: Subject to compliance with requirements, manufacturers offering products that may be incorporated into the Work include, but are not limited to, the manufacturers specified.
2. Manufacturers: Subject to compliance with requirements, provide products by the manufacturers specified.

2.02 PIPE, TUBE, AND FITTINGS

- A. Refer to individual Division 22 piping Sections for pipe, tube, and fitting materials and joining methods.
- B. Pipe Threads: ASME B1.20.1 for factory-threaded pipe and pipe fittings.

2.03 JOINING MATERIALS

- A. Refer to individual Division 22 piping Sections for special joining materials not listed below.
- B. Pipe-Flange Gasket Materials: Suitable for chemical and thermal conditions of piping system contents.
 1. ASME B16.21, nonmetallic, flat, asbestos-free, 1/8-inch maximum thickness unless thickness or specific material is indicated.
 - a. Full-Face Type: For flat-face, Class 125, cast-iron and cast-bronze flanges.
 - b. Narrow-Face Type: For raised-face, Class 250, cast-iron and steel flanges.
 2. AWWA C110, rubber, flat face, 1/8 inch thick, unless otherwise indicated; and full-face or ring type, unless otherwise indicated.
- C. Flange Bolts and Nuts: ASME B18.2.1, carbon steel, unless otherwise indicated.
- D. Plastic, Pipe-Flange Gasket, Bolts, and Nuts: Type and material recommended by piping system manufacturer, unless otherwise indicated.
- E. Solder Filler Metals: ASTM B 32, lead-free alloys. Include water-flushable flux according to ASTM B 813.
- F. Brazing Filler Metals: AWS A5.8, BCuP Series, copper-phosphorus alloys for general-duty brazing, unless otherwise indicated; and AWS A5.8, BAg1, silver alloy for refrigerant piping, unless otherwise indicated.
- G. Welding Filler Metals: Comply with AWS D10.12 for welding materials appropriate for wall thickness and chemical analysis of steel pipe being welded.
- H. Solvent Cements for Joining Plastic Piping:
 1. ABS Piping: ASTM D 2235.
 2. CPVC Piping: ASTM F 493.
 3. PVC Piping: ASTM D 2564. Include primer according to ASTM F 656.
 4. PVC to ABS Piping Transition: ASTM D 3138.
- I. Fiberglass Pipe Adhesive: As furnished or recommended by pipe manufacturer.

2.04 TRANSITION FITTINGS

- A. AWWA Transition Couplings: Same size as, and with pressure rating at least equal to and with ends compatible with, piping to be joined.
 1. Manufacturers:
 - a. Cascade Waterworks Mfg. Co.
 - b. Dresser Industries, Inc.; DMD Div.

- c. Ford Meter Box Company, Incorporated (The); Pipe Products Div.
 - d. JCM Industries.
 - e. Smith-Blair, Inc.
 - f. Viking Johnson.
2. Underground Piping NPS 1-1/2 and Smaller: Manufactured fitting or coupling.
 3. Underground Piping NPS 2 and Larger: AWWA C219, metal sleeve-type coupling.
 4. Aboveground Pressure Piping: Pipe fitting.
- B. Plastic-to-Metal Transition Fittings: CPVC and PVC one-piece fitting with manufacturer's Schedule 80 equivalent dimensions; one end with threaded brass insert, and one solvent-cement-joint end.
1. Manufacturers:
 - a. Eslon Thermoplastics.
- C. Plastic-to-Metal Transition Adaptors: One-piece fitting with manufacturer's SDR 11 equivalent dimensions; one end with threaded brass insert, and one solvent-cement-joint end.
1. Manufacturers:
 - a. Thompson Plastics, Inc.
- D. Plastic-to-Metal Transition Unions: MSS SP-107, CPVC PVC CPVC and PVC four-part union. Include brass end, solvent-cement-joint end, rubber O-ring, and union nut.
1. Manufacturers:
 - a. NIBCO INC.
 - b. NIBCO, Inc.; Chemtrol Div.
- E. Flexible Transition Couplings for Underground Non-pressure Drainage Piping: ASTM C 1173 with elastomeric sleeve, ends same size as piping to be joined, and corrosion-resistant metal band on each end.
1. Manufacturers:
 - a. Cascade Waterworks Mfg. Co.
 - b. Fernco, Inc.
 - c. Mission Rubber Company.
 - d. Plastic Oddities, Inc.

2.05 DIELECTRIC FITTINGS

- A. Description: Combination fitting of copper alloy and ferrous materials with threaded, solder-joint, plain, or weld-neck end connections that match piping system materials.
- B. Insulating Material: Suitable for system fluid, pressure, and temperature.
- C. Dielectric Unions: Factory-fabricated, union assembly, for 250-psig minimum working pressure at 180 deg F
- D. Coordinate subparagraph and associated subparagraphs below with Part 2 "Manufacturers" Article. Retain "Available" for nonproprietary and delete for semiproprietary specifications.
 1. Manufacturers:
 - a. Capitol Manufacturing Co.
 - b. Central Plastics Company.
 - c. Eclipse, Inc.
 - d. Epco Sales, Inc.

- e. Hart Industries, International, Inc.
 - f. Watts Industries, Inc.; Water Products Div.
 - g. Zurn Industries, Inc.; Wilkins Div.
- E. Dielectric Flanges: Factory-fabricated, companion-flange assembly, for 150- or 300-psig minimum working pressure as required to suit system pressures.
- 1. Manufacturers:
 - a. Capitol Manufacturing Co.
 - b. Central Plastics Company.
 - c. Epco Sales, Inc.
 - d. Watts Industries, Inc.; Water Products Div.
- F. Dielectric-Flange Kits: Companion-flange assembly for field assembly. Include flanges, full-face- or ring-type neoprene or phenolic gasket, phenolic or polyethylene bolt sleeves, phenolic washers, and steel backing washers.
- 1. Manufacturers:
 - a. Advance Products & Systems, Inc.
 - b. Calpico, Inc.
 - c. Central Plastics Company.
 - d. Pipeline Seal and Insulator, Inc.
 - 2. Separate companion flanges and steel bolts and nuts shall have 150- or 300-psig minimum working pressure where required to suit system pressures.
- G. Dielectric Couplings: Galvanized-steel coupling with inert and noncorrosive, thermoplastic lining; threaded ends; and 300-psig minimum working pressure at 225 deg F
- 1. Manufacturers:
 - a. Calpico, Inc.
 - b. Lochinvar Corp.
- H. Dielectric Nipples: Electroplated steel nipple with inert and noncorrosive, thermoplastic lining; plain, threaded, or grooved ends; and 300-psig minimum working pressure at 225 deg F.
- 1. Manufacturers:
 - a. Perfection Corp.
 - b. Precision Plumbing Products, Inc.
 - c. Sioux Chief Manufacturing Co., Inc.
 - d. Victaulic Co. of America.

2.06 MECHANICAL SLEEVE SEALS

- A. Description: Modular sealing element unit, designed for field assembly, to fill annular space between pipe and sleeve.
- 1. Manufacturers:
 - a. Advance Products & Systems, Inc.
 - b. Calpico, Inc.
 - c. Metraflex Co.
 - d. Pipeline Seal and Insulator, Inc.
 - 2. Sealing Elements: EPDM interlocking links shaped to fit surface of pipe. Include type and number required for pipe material and size of pipe.

3. Pressure Plates: Carbon steel. Include two for each sealing element.
4. Connecting Bolts and Nuts: Stainless steel of length required to secure pressure plates to sealing elements. Include one for each sealing element.

2.07 SLEEVES

- A. Galvanized-Steel Sheet: 0.0239-inch minimum thickness; round tube closed with welded longitudinal joint.
- B. Steel Pipe: ASTM A 53, Type E, Grade B, Schedule 40, galvanized, plain ends.
- C. Cast Iron: Cast or fabricated "wall pipe" equivalent to ductile-iron pressure pipe, with plain ends and integral waterstop, unless otherwise indicated.
- D. Stack Sleeve Fittings: Manufactured, cast-iron sleeve with integral clamping flange. Include clamping ring and bolts and nuts for membrane flashing.
 1. Under deck Clamp: Clamping ring with set screws.
- E. Molded PVC: Permanent, with nailing flange for attaching to wooden forms.
- F. PVC Pipe: ASTM D 1785, Schedule 40.
- G. Molded PE: Reusable, PE, tapered-cup shaped and smooth-outer surface with nailing flange for attaching to wooden forms.

2.08 ESCUTCHEONS

- A. Description: Manufactured wall and ceiling escutcheons and floor plates, with an ID to closely fit around pipe, tube, and insulation of insulated piping and an OD that completely covers opening.
- B. One-Piece, Deep-Pattern Type: Deep-drawn, box-shaped brass with polished chrome-plated finish.
- C. One-Piece, Cast-Brass Type: With set screw.
 1. Finish: Polished chrome-plated.
- D. Split-Casting, Cast-Brass Type: With concealed hinge and set screw.
 1. Finish: Polished chrome-plated.
- E. One-Piece, Stamped-Steel Type: With set screw set screw or spring clips and chrome-plated finish.
- F. Split-Plate, Stamped-Steel Type: With concealed hinge, set screw or spring clips, and chrome-plated finish.
- G. One-Piece, Floor-Plate Type: Cast-iron floor plate.
- H. Split-Casting, Floor-Plate Type: Cast brass with concealed hinge and set screw.

2.09 GROUT

- A. Description: ASTM C 1107, Grade B, non-shrink and nonmetallic, dry hydraulic-cement grout.
 1. Characteristics: Post-hardening, volume-adjusting, non-staining, noncorrosive, nongaseous, and recommended for interior and exterior applications.
 2. Design Mix: 5000-psi, 28-day compressive strength.
 3. Packaging: Premixed and factory packaged.

PART 3 - EXECUTION

3.01 PLUMBING DEMOLITION

- A. Refer to Division 01 Section "Cutting and Patching" and Division 02 Section "Selective Structure Demolition" for general demolition requirements and procedures.
- B. Disconnect, demolish, and remove plumbing systems, equipment, and components indicated to be removed.
 - 1. Piping to Be Removed: Remove portion of piping indicated to be removed and cap or plug remaining piping with same or compatible piping material.
 - 2. Piping to Be Abandoned in Place: Drain piping and cap or plug piping with same or compatible piping material.
 - 3. Equipment to Be Removed: Disconnect and cap services and remove equipment.
 - 4. Equipment to Be Removed and Reinstalled: Disconnect and cap services and remove, clean, and store equipment; when appropriate, reinstall, reconnect, and make equipment operational.
 - 5. Equipment to Be Removed and Salvaged: Disconnect and cap services and remove equipment and deliver to Owner.
- C. If pipe, insulation, or equipment to remain is damaged in appearance or is unserviceable, remove damaged or unserviceable portions and replace with new products of equal capacity and quality.

3.02 PIPING SYSTEMS - COMMON REQUIREMENTS

- A. Install piping according to the following requirements and Division 22 Sections specifying piping systems.
- B. Drawing plans, schematics, and diagrams indicate general location and arrangement of piping systems. Indicated locations and arrangements were used to size pipe and calculate friction loss, expansion, pump sizing, and other design considerations. Install piping as indicated unless deviations to layout are approved on Coordination Drawings.
- C. Install piping in concealed locations, unless otherwise indicated and except in equipment rooms and service areas.
- D. Install piping indicated to be exposed and piping in equipment rooms and service areas at right angles or parallel to building walls. Diagonal runs are prohibited unless specifically indicated otherwise.
- E. Install piping above accessible ceilings to allow sufficient space for ceiling panel removal.
- F. Install piping to permit valve servicing.
- G. Install piping at indicated slopes.
- H. Install piping free of sags and bends.
- I. Install fittings for changes in direction and branch connections.
- J. Install piping to allow application of insulation.
- K. Select system components with pressure rating equal to or greater than system operating pressure.
- L. Install escutcheons for penetrations of walls, ceilings, and floors according to the following:
 - 1. New Piping:
 - a. Piping with Fitting or Sleeve Protruding from Wall: One-piece, deep-pattern type.
 - b. Chrome-Plated Piping: One-piece, cast-brass type with polished chrome-plated finish.

- c. Insulated Piping: One-piece, stamped-steel type with spring clips.
 - d. Bare Piping at Wall and Floor Penetrations in Finished Spaces: One-piece, cast-brass type with polished chrome-plated finish.
 - e. Bare Piping at Wall and Floor Penetrations in Finished Spaces: One-piece, stamped-steel type.
 - f. Bare Piping at Ceiling Penetrations in Finished Spaces: One-piece, cast-brass type with polished chrome-plated finish.
 - g. Bare Piping in Unfinished Service Spaces: One-piece, cast-brass type with polished chrome-plated finish.
 - h. Bare Piping in Equipment Rooms: One-piece, cast-brass type.
 - i. Bare Piping in Equipment Rooms: One-piece, stamped-steel type with set screw or spring clips.
 - j. Bare Piping at Floor Penetrations in Equipment Rooms: One-piece, floor-plate type.
2. Existing Piping: Use the following:
- a. Chrome-Plated Piping: Split-casting, cast-brass type with chrome-plated finish.
 - b. Insulated Piping: Split-plate, stamped-steel type with concealed hinge and spring clips.
 - c. Bare Piping at Wall and Floor Penetrations in Finished Spaces: Split-casting, cast-brass type with chrome-plated finish.
 - d. Bare Piping at Wall and Floor Penetrations in Finished Spaces: Split-plate, stamped-steel type with concealed hinge and spring clips.
 - e. Bare Piping at Ceiling Penetrations in Finished Spaces: Split-casting, cast-brass type with chrome-plated finish.
 - f. Bare Piping at Ceiling Penetrations in Finished Spaces: Split-plate, stamped-steel type with concealed hinge and set screw.
 - g. Bare Piping in Unfinished Service Spaces: Split-casting, cast-brass type with polished chrome-plated finish.
 - h. Bare Piping in Unfinished Service Spaces: Split-plate, stamped-steel type with concealed hinge and set screw or spring clips.
 - i. Bare Piping in Equipment Rooms: Split-casting, cast-brass type.
 - j. Bare Piping in Equipment Rooms: Split-plate, stamped-steel type with set screw or spring clips.
 - k. Bare Piping at Floor Penetrations in Equipment Rooms: Split-casting, floor-plate type.
- M. Sleeves are not required for core-drilled holes.
- N. Permanent sleeves are not required for holes formed by removable PE sleeves.
- O. Install sleeves for pipes passing through concrete and masonry walls and concrete floor and roof slabs.
- P. Install sleeves for pipes passing through concrete and masonry walls, gypsum-board partitions, and concrete floor and roof slabs.
- 1. Cut sleeves to length for mounting flush with both surfaces.
 - a. Exception: Extend sleeves installed in floors of mechanical equipment areas or other wet areas 2 inches above finished floor level. Extend cast-iron sleeve fittings below floor slab as required to secure clamping ring if ring is specified.
 - 2. Install sleeves in new walls and slabs as new walls and slabs are constructed.

3. Install sleeves that are large enough to provide 1/4-inch annular clear space between sleeve and pipe or pipe insulation. Use the following sleeve materials:
 - a. Steel Pipe Sleeves: For pipes smaller than NPS 6.
 - b. Steel Sheet Sleeves: For pipes NPS 6 and larger, penetrating gypsum-board partitions.
 - c. Stack Sleeve Fittings: For pipes penetrating floors with membrane waterproofing. Secure flashing between clamping flanges. Install section of cast-iron soil pipe to extend sleeve to 2 inches above finished floor level. Refer to Division 07 Section "Sheet Metal Flashing and Trim" for flashing.
- (1) Seal space outside of sleeve fittings with grout.
4. Except for underground wall penetrations, seal annular space between sleeve and pipe or pipe insulation, using joint sealants appropriate for size, depth, and location of joint. Refer to Division 07 Section "Joint Sealants" for materials and installation.
- Q. Above ground, Exterior-Wall Pipe Penetrations: Seal penetrations using sleeves and mechanical sleeve seals. Select sleeve size to allow for 1-inch annular clear space between pipe and sleeve for installing mechanical sleeve seals.
 1. Install steel pipe for sleeves smaller than 6 inches in diameter.
 2. Install cast-iron "wall pipes" for sleeves 6 inches and larger in diameter.
 3. Mechanical Sleeve Seal Installation: Select type and number of sealing elements required for pipe material and size. Position pipe in center of sleeve. Assemble mechanical sleeve seals and install in annular space between pipe and sleeve. Tighten bolts against pressure plates that cause sealing elements to expand and make watertight seal.
- R. Underground, Exterior-Wall Pipe Penetrations: Install cast-iron "wall pipes" for sleeves. Seal pipe penetrations using mechanical sleeve seals. Select sleeve size to allow for 1-inch annular clear space between pipe and sleeve for installing mechanical sleeve seals.
 1. Mechanical Sleeve Seal Installation: Select type and number of sealing elements required for pipe material and size. Position pipe in center of sleeve. Assemble mechanical sleeve seals and install in annular space between pipe and sleeve. Tighten bolts against pressure plates that cause sealing elements to expand and make watertight seal.
- S. Edit first paragraph below to suit Project and add description of firestopping sealant.
- T. Fire-Barrier Penetrations: Maintain indicated fire rating of walls, partitions, ceilings, and floors at pipe penetrations. Seal pipe penetrations with fire stop materials. Refer to Division 07 Section "Penetration Fire stopping" for materials.
- U. Verify final equipment locations for roughing-in.
- V. Refer to equipment specifications in other Sections of these Specifications for roughing-in requirements.

3.03 PIPING JOINT CONSTRUCTION

- A. Join pipe and fittings according to the following requirements and Division 22 Sections specifying piping systems.
- B. Ream ends of pipes and tubes and remove burrs. Bevel plain ends of steel pipe.
- C. Remove scale, slag, dirt, and debris from inside and outside of pipe and fittings before assembly.
- D. Soldered Joints: Apply ASTM B 813, water-flushable flux, unless otherwise indicated, to tube end. Construct joints according to ASTM B 828 or CDA's "Copper Tube Handbook," using lead-free solder alloy complying with ASTM B 32.

- E. Brazed Joints: Construct joints according to AWS's "Brazing Handbook," "Pipe and Tube" Chapter, using copper-phosphorus brazing filler metal complying with AWS A5.8.
- F. Threaded Joints: Thread pipe with tapered pipe threads according to ASME B1.20.1. Cut threads full and clean using sharp dies. Ream threaded pipe ends to remove burrs and restore full ID. Join pipe fittings and valves as follows:
 - 1. Apply appropriate tape or thread compound to external pipe threads unless dry seal threading is specified.
 - 2. Damaged Threads: Do not use pipe or pipe fittings with threads that are corroded or damaged. Do not use pipe sections that have cracked or open welds.
- G. Welded Joints: Construct joints according to AWS D10.12, using qualified processes and welding operators according to Part 1 "Quality Assurance" Article.
- H. Flanged Joints: Select appropriate gasket material, size, type, and thickness for service application. Install gasket concentrically positioned. Use suitable lubricants on bolt threads.
- I. Plastic Piping Solvent-Cement Joints: Clean and dry joining surfaces. Join pipe and fittings according to the following:
 - 1. Comply with ASTM F 402 for safe-handling practice of cleaners, primers, and solvent cements.
 - 2. ABS Piping: Join according to ASTM D 2235 and ASTM D 2661 Appendixes.
 - 3. CPVC Piping: Join according to ASTM D 2846/D 2846M Appendix.
 - 4. PVC Pressure Piping: Join schedule number ASTM D 1785, PVC pipe and PVC socket fittings according to ASTM D 2672. Join other-than-schedule-number PVC pipe and socket fittings according to ASTM D 2855.
 - 5. PVC Non-pressure Piping: Join according to ASTM D 2855.
 - 6. PVC to ABS Non-pressure Transition Fittings: Join according to ASTM D 3138 Appendix.
- J. Plastic Pressure Piping Gasketed Joints: Join according to ASTM D 3139.
- K. Plastic Non-pressure Piping Gasketed Joints: Join according to ASTM D 3212.
- L. PE Piping Heat-Fusion Joints: Clean and dry joining surfaces by wiping with clean cloth or paper towels. Join according to ASTM D 2657.
 - 1. Plain-End Pipe and Fittings: Use butt fusion.
 - 2. Plain-End Pipe and Socket Fittings: Use socket fusion.

3.04 PIPING CONNECTIONS

- A. Make connections according to the following, unless otherwise indicated:
 - 1. Install unions, in piping NPS 2 and smaller, adjacent to each valve and at final connection to each piece of equipment.
 - 2. Install flanges, in piping NPS 2-1/2 and larger, adjacent to flanged valves and at final connection to each piece of equipment.
 - 3. Dry Piping Systems: Install dielectric unions and flanges to connect piping materials of dissimilar metals.
 - 4. Wet Piping Systems: Install dielectric coupling and nipple fittings to connect piping materials of dissimilar metals.

3.05 EQUIPMENT INSTALLATION - COMMON REQUIREMENTS

- A. Install equipment to allow maximum possible headroom unless specific mounting heights are not indicated.
- B. Install equipment level and plumb, parallel and perpendicular to other building systems and components in exposed interior spaces, unless otherwise indicated.
- C. Install plumbing equipment to facilitate service, maintenance, and repair or replacement of components. Connect equipment for ease of disconnecting, with minimum interference to other installations. Extend grease fittings to accessible locations.
- D. Install equipment to allow right of way for piping installed at required slope.

3.06 PAINTING

- A. Painting of plumbing systems, equipment, and components is specified in Division 09 Sections "Interior Painting" and "Exterior Painting."
- B. Damage and Touchup: Repair marred and damaged factory-painted finishes with materials and procedures to match original factory finish.

3.07 CONCRETE BASES

- A. Concrete Bases: Anchor equipment to concrete base according to equipment manufacturer's written instructions and according to seismic codes at Project.
 - 1. Construct concrete bases of dimensions indicated, but not less than 4 inches larger in both directions than supported unit.
 - 2. Install dowel rods to connect concrete base to concrete floor. Unless otherwise indicated, install dowel rods on 18-inch centers around the full perimeter of the base.
 - 3. Install epoxy-coated anchor bolts for supported equipment that extend through concrete base, and anchor into structural concrete floor.
 - 4. Place and secure anchorage devices. Use supported equipment manufacturer's setting drawings, templates, diagrams, instructions, and directions furnished with items to be embedded.
 - 5. Install anchor bolts to elevations required for proper attachment to supported equipment.
 - 6. Install anchor bolts according to anchor-bolt manufacturer's written instructions.
 - 7. Use 3000-psi, 28-day compressive-strength concrete and reinforcement as specified in Division 03 Section "Cast-in-Place Concrete."

3.08 ERECTION OF METAL SUPPORTS AND ANCHORAGES

- A. Refer to Division 05 Section "Metal Fabrications" for structural steel.
- B. Cut, fit, and place miscellaneous metal supports accurately in location, alignment, and elevation to support and anchor plumbing materials and equipment.
- C. Field Welding: Comply with AWS D1.1.

3.09 GROUTING

- A. Mix and install grout for plumbing equipment base bearing surfaces, pump and other equipment base plates, and anchors.
- B. Clean surfaces that will come into contact with grout.
- C. Provide forms as required for placement of grout.
- D. Avoid air entrapment during placement of grout.
- E. Place grout, completely filling equipment bases.

- F. Place grout on concrete bases and provide smooth bearing surface for equipment.
- G. Place grout around anchors.
- H. Cure placed grout.

END OF SECTION

SECTION 220519- METERS AND GAGES FOR PLUMBING PIPING

PART 1-GENERAL

1.01 RELATED DOCUMENTS

- A. Drawings and general provisions of the Contract, including General and Supplementary Conditions and Division 01 Specification Sections, apply to this Section.

1.02 SUMMARY

- A. Section Includes:

1. Bimetallic-actuated thermometers.
2. Filled-system thermometers.
3. Liquid-in-glass thermometers.
4. Light-activated thermometers.
5. Thermo-wells.
6. Dial-type pressure gages.
7. Gage attachments.
8. Test plugs.
9. Test-plug kits.
10. Sight flow indicators.

- B. Related Sections:

1. Division 21 Section "Facility Fire-Suppression Water-Service Piping" for fire-protection water-service meters outside the building.
2. Division 21 fire-suppression piping Sections for fire-protection pressure gages.
3. Division 22 Section "Facility Water Distribution Piping" for domestic water meters and combined domestic and fire-protection water-service meters outside the building.
4. Division 22 Section "Domestic Water Piping" for water meters inside the building.

1.03 SUBMITTALS

- A. Product Data: For each type of product indicated.
- B. Product Certificates: For each type of meter and gage, from manufacturer.
- C. Operation and Maintenance Data: For meters and gages to include in operation and maintenance manuals.

PART 2- PRODUCTS

2.01 BIMETALLIC-ACTUATED THERMOMETERS

- A. Manufacturers: Subject to compliance with requirements, provide products by one of the following available manufacturers offering products that may be incorporated into the Work include, but are not limited to, the following:
- B. Basis-of-Design Product: Subject to compliance with requirements, provide product indicated on Drawings Insert manufacturer's name; product name or designation or comparable product by one of the following:

1. Ashcroft Inc.
 2. Ernst Flow Industries.
 3. Marsh Bellofram.
 4. Nanmac Corporation.
 5. Palmer Wahl Instrumentation Group.
 6. REOTEMP Instrument Corporation.
 7. Tel-Tru Manufacturing Company.
 8. Trerice, H. O. Co.
 9. Watts Regulator Co.; a div. of Watts Water Technologies, Inc.
 10. Weiss Instruments, Inc.
 11. WIKA Instrument Corporation - USA.
 12. Winters Instruments - U.S.
- C. Standard: ASME B40.200.
- D. Case: Liquid-filled and sealed type(s); stainless steel with 3-inch 5-inch nominal diameter.
- E. Dial: Non-reflective aluminum with permanently etched scale markings and scales in deg F and deg C.
- F. Connector Type(s): Union joint, adjustable angle rigid, back and rigid, bottom, with unified-inch screw threads.
- G. Connector Size: 1/2 inch, with ASME B1.1 screw threads.
- H. Stem: 0.25 or 0.375 inch in diameter; stainless steel.
- I. Window: Plain glass or plastic.
- J. Ring: Stainless steel.
- K. Element: Bimetal coil.
- L. Pointer: Dark-colored metal.
- M. Accuracy: Plus or minus 1, 1.5 percent of scale range.

2.02 FILLED-SYSTEM THERMOMETERS

- A. Direct-Mounted, Metal-Case, Vapor-Actuated Thermometers:
1. Manufacturers: Subject to compliance with requirements, provide products by one of the following available manufacturers offering products that may be incorporated into the Work include, but are not limited to, the following:
 - a. Ashcroft Inc.
 - b. Marsh Bellofram.
 - c. Miljoco Corporation.
 - d. Palmer Wahl Instrumentation Group.
 - e. REOTEMP Instrument Corporation.
 - f. Trerice, H. O. Co.
 - g. Weiss Instruments, Inc.
 2. Standard: ASME B40.200.
 3. Case: Sealed type, cast aluminum or drawn steel; 4-1/2-inch, 5-inch, 6-inch nominal diameter.

4. Element: Bourdon tube or other type of pressure element.
 5. Movement: Mechanical, dampening type, with link to pressure element and connection to pointer.
 6. Dial: Non-reflective aluminum with permanently etched scale markings graduated in deg F and deg C.
 7. Pointer: Dark-colored metal.
 8. Window: Glass or plastic.
 9. Ring: Metal Stainless steel.
 10. Connector Type(s): Union joint, adjustable, 180 degrees in vertical plane, 360 degrees in horizontal plane, with locking device rigid, back and rigid, bottom; with ASME B1.1 screw threads.
 11. Thermal System: Liquid-filled bulb in copper-plated steel, aluminum, or brass stem and of length to suit installation.
 - a. Design for Thermo well Installation: Bare stem.
 12. Accuracy: Plus or minus 1 percent of scale range.
- B. Direct-Mounted, Plastic-Case, Vapor-Actuated Thermometers:
1. Manufacturers: Subject to compliance with requirements, provide products by one of the following available manufacturers offering products that may be incorporated into the Work include, but are not limited to, the following:
 - a. Ashcroft Inc.
 - b. Miljoco Corporation.
 - c. REOTEMP Instrument Corporation.
 2. Standard: ASME B40.200.
 3. Case: Sealed type, plastic <Insert material>; 4-1/2-inch 5-inch 6-inch nominal diameter.
 4. Element: Bourdon tube or other type of pressure element.
 5. Movement: Mechanical, with link to pressure element and connection to pointer.
 6. Dial: Non-reflective aluminum with permanently etched scale markings graduated in deg F and deg C.
 7. Pointer: Dark-colored metal.
 8. Window: Glass or plastic
 9. Ring: Metal or plastic.
 10. Connector Type(s): Union joint, adjustable, 180 degrees in vertical plane, 360 degrees in horizontal plane, with locking device rigid, back and rigid, bottom; with ASME B1.1 screw threads.
 11. Thermal System: Liquid-filled bulb in copper-plated steel, aluminum, or brass stem and of length to suit installation.
 - a. Design for Thermowell Installation: Bare stem.
 12. Accuracy: Plus or minus 1 percent of scale range.

2.03 LIQUID-IN-GLASS THERMOMETERS

- A. Metal-Case, Compact-Style, Liquid-in-Glass Thermometers:
1. Manufacturers: Subject to compliance with requirements, provide products by one of the following available manufacturers offering products that may be incorporated into the Work include, but are not limited to, the following:

- a. Terrice, H. O. Co.
2. Standard: ASME B40.200.
3. Case: Cast aluminum; 6-inch nominal size.
4. Case Form: Back angle Straight unless otherwise indicated.
5. Tube: Glass with magnifying lens and blue or red organic liquid.
6. Tube Background: Non-reflective aluminum with permanently etched scale markings graduated in deg F deg F and deg C.
7. Window: Glass or plastic.
8. Stem: Aluminum or brass and of length to suit installation.
9. Design for Thermowell Installation: Bare stem.
10. Connector: 3/4 inch, with ASME B1.1 screw threads.
11. Accuracy: Plus or minus 1 percent of scale range or one scale division, to a maximum of 1.5 percent of scale range.

2.04 THERMOWELLS

- A. Thermo-wells:
 1. Standard: ASME B40.200.
 2. Description: Pressure-tight, socket-type fitting made for insertion into piping tee fitting.
 3. Material for Use with Copper Tubing: CNR or CUNI.
 4. Material for Use with Steel Piping: CRES CSA .
 5. Type: Stepped shank unless straight or tapered shank is indicated.
 6. External Threads: NPS 1/2, NPS 3/4, or NPS 1, ASME B1.20.1 pipe threads.
 7. Internal Threads: 1/2, 3/4, and 1 inch, with ASME B1.1 screw threads.
 8. Bore: Diameter required to match thermometer bulb or stem.
 9. Insertion Length: Length required to match thermometer bulb or stem.
 10. Lagging Extension: Include on thermowells for insulated piping and tubing.
 11. Bushings: For converting size of thermowell's internal screw thread to size of thermometer connection.
- B. Heat-Transfer Medium: Mixture of graphite and glycerin <Insert material>.

2.05 PRESSURE GAGES

- A. Direct-Mounted, Metal-Case, Dial-Type Pressure Gages:
 1. Manufacturers: Subject to compliance with requirements, provide products by one of the following available manufacturers offering products that may be incorporated into the Work include, but are not limited to, the following:
 - a. AMETEK, Inc.; U.S. Gauge.
 - b. Ashcroft Inc.
 - c. Ernst Flow Industries.
 - d. Flo Fab Inc.
 - e. Marsh Bellofram.
 - f. Miljoco Corporation.
 - g. Palmer Wahl Instrumentation Group.
 - h. REOTEMP Instrument Corporation.

- i. Tel-Tru Manufacturing Company.
 - j. Trerice, H. O. Co.
 - k. Watts Regulator Co.; a div. of Watts Water Technologies, Inc.
 - l. Weiss Instruments, Inc.
 - m. WIKA Instrument Corporation - USA.
 - n. Winters Instruments - U.S.
2. Standard: ASME B40.100.
 3. Case: Liquid-filled Sealed Open-front, pressure relief Solid-front, pressure relief Insert type type(s); cast aluminum or drawn steel 4-1/2-inch 6-inch nominal diameter.
 4. Pressure-Element Assembly: Bourdon tube unless otherwise indicated.
 5. Pressure Connection: Brass, with NPS 1/4 NPS 1/4 or NPS 1/2 NPS 1/2, ASME B1.20.1 pipe threads and bottom-outlet type unless back-outlet type is indicated.
 6. Movement: Mechanical, with link to pressure element and connection to pointer.
 7. Dial: Non-reflective aluminum with permanently etched scale markings graduated in psi and kPa.
 8. Pointer: Dark-colored metal.
 9. Window: Glass or plastic.
 10. Ring: Metal Brass Stainless steel.
 11. Accuracy: Grade A, plus or minus 1 percent of middle half of Grade B, plus or minus 2 percent of middle half of Grade C, plus or minus 3 percent of middle half of Grade D, plus or minus 5 percent of whole scale range.

2.06 GAGE ATTACHMENTS

- A. Snubbers: ASME B40.100, brass; with NPS 1/4 NPS 1/4 or NPS 1/2 NPS 1/2, ASME B1.20.1 pipe threads and piston porous-metal-type surge-dampening device. Include extension for use on insulated piping.
- B. Valves: Brass ball Brass or stainless-steel needle, with NPS 1/4 NPS 1/4 or NPS 1/2 NPS 1/2, ASME B1.20.1 pipe threads.

2.07 TEST PLUGS

- A. Manufacturers: Subject to compliance with requirements, provide products by one of the following available manufacturers offering products that may be incorporated into the Work include, but are not limited to, the following:
 1. Flow Design, Inc.
 2. Miljoco Corporation.
 3. National Meter, Inc.
 4. Peterson Equipment Co., Inc.
 5. Sisco Manufacturing Company, Inc.
 6. Trerice, H. O. Co.
 7. Watts Regulator Co.; a div. of Watts Water Technologies, Inc.
 8. Weiss Instruments, Inc.
- B. Description: Test-station fitting made for insertion into piping tee fitting.
- C. Body: Brass or stainless steel with core inserts and gasketed and threaded cap. Include extended stem on units to be installed in insulated piping.

- D. Thread Size: NPS 1/4 or NPS 1/2, ASME B1.20.1 pipe thread.
- E. Minimum Pressure and Temperature Rating: 500 psig at 200 deg F
- F. Core Inserts: Chlorosulfonated polyethylene synthetic and EPDM self-sealing rubber.

2.08 TEST-PLUG KITS

- A. Manufacturers: Subject to compliance with requirements, provide products by one of the following available manufacturers offering products that may be incorporated into the Work include, but are not limited to, the following:
 - 1. Flow Design, Inc.
 - 2. Miljoco Corporation.
 - 3. National Meter, Inc.
 - 4. Peterson Equipment Co., Inc.
 - 5. Sisco Manufacturing Company, Inc.
 - 6. Trerice, H. O. Co.
 - 7. Watts Regulator Co.; a div. of Watts Water Technologies, Inc.
 - 8. Weiss Instruments, Inc.
- B. Furnish one test-plug kit(s) containing one two thermometer(s), one pressure gage and adapter, and carrying case. Thermometer sensing elements, pressure gage, and adapter probes shall be of diameter to fit test plugs and of length to project into piping.
- C. Retain one of first two paragraphs below. If retaining both, indicate location of each on Drawings.
- D. Low-Range Thermometer: Small, bimetallic insertion type with 1- to 2-inch- diameter dial and tapered-end sensing element. Dial range shall be at least 25 to 125 deg F (minus 4 to plus 52 deg C).
- E. High-Range Thermometer: Small, bimetallic insertion type with 1- to 2-inch- diameter dial and tapered-end sensing element. Dial range shall be at least 0 to 220 deg F (minus 18 to plus 104 deg C).
- F. Pressure Gage: Small, Bourdon-tube insertion type with 2- to 3-inch- <Insert dimension> diameter dial and probe. Dial range shall be at least 0 to 200 psig.
- G. Carrying Case: Metal or plastic, with formed instrument padding.

PART 3- EXECUTION

3.01 INSTALLATION

- A. Install thermowells with socket extending a minimum of 2 inches into fluid one-third of pipe diameter to center of pipe and in vertical position in piping tees.
- B. Install thermowells of sizes required to match thermometer connectors. Include bushings if required to match sizes.
- C. Install thermowells with extension on insulated piping.
- D. Fill thermowells with heat-transfer medium.
- E. Install direct-mounted thermometers in thermowells and adjust vertical and tilted positions.
- F. Install remote-mounted thermometer bulbs in thermowells and install cases on panels; connect cases with tubing and support tubing to prevent kinks. Use minimum tubing length.

- G. Install direct-mounted pressure gages in piping tees with pressure gage located on pipe at the most readable position.
- H. Install remote-mounted pressure gages on panel.
- I. Install valve and snubber in piping for each pressure gage for fluids.
- J. Install test plugs in piping tees.
- K. Install thermometers in the following locations:
 - 1. Inlet and outlet of each water heater.
 - 2. Inlets and outlets of each domestic water heat exchanger.
 - 3. Inlet and outlet of each domestic hot-water storage tank.
 - 4. Inlet and outlet of each remote domestic water chiller.
- L. Install pressure gages in the following locations:
 - 1. Building water service entrance into building.
 - 2. Inlet and outlet of each pressure-reducing valve.
 - 3. Suction and discharge of each domestic water pump.

3.02 CONNECTIONS

- A. Install meters and gages adjacent to machines and equipment to allow service and maintenance of meters, gages, machines, and equipment.

3.04 ADJUSTING

- A. Adjust faces of meters and gages to proper angle for best visibility.

3.04 THERMOMETER SCHEDULE

- A. Retain this article if more than one type of thermometer is required; delete if all thermometers are the same type.
- B. Thermometers at inlets and outlets of each domestic water heat exchanger shall be one of the following:
 - 1. Liquid-filled Sealed, bimetallic-actuated type.
 - 2. Direct Remote-mounted, metal plastic-case, vapor-actuated type.
 - 3. Compact Industrial-style, liquid-in-glass type.
 - 4. Direct Remote-mounted, light-activated type.
 - 5. Test plug with chlorosulfonated polyethylene synthetic EPDM self-sealing rubber inserts.
- C. Retain "one of" option in first paragraph below to allow Contractor to select thermometer materials from those retained.
- D. Thermometers at inlet and outlet of each domestic hot-water storage tank shall be one of the following:
 - 1. Liquid-filled Sealed, bimetallic-actuated type.
 - 2. Direct Remote-mounted, metal plastic-case, vapor-actuated type.
 - 3. Compact Industrial-style, liquid-in-glass type.
 - 4. Direct Remote-mounted, light-activated type.
 - 5. Test plug with chlorosulfonated polyethylene synthetic EPDM self-sealing rubber inserts.
 - 6. Test plug with chlorosulfonated polyethylene synthetic EPDM self-sealing rubber inserts.
- E. Insert additional paragraphs for thermometer applications here.

F. Thermometer stems shall be of length to match thermowell insertion length.

END OF SECTION

SECTION 220529- HANGERS AND SUPPORTS FOR PLUMBING PIPING AND EQUIPMENT

PART 1 – GENERAL

1.01 RELATED DOCUMENTS

- A. Drawings and general provisions of the Contract, including General and Supplementary Conditions and Division 01 Specification Sections, apply to this Section.

1.02 SUMMARY

- A. This Section includes the following hangers and supports for plumbing system piping and equipment:
 - 1. Steel pipe hangers and supports.
 - 2. Trapeze pipe hangers.
 - 3. Metal framing systems.
 - 4. Thermal-hanger shield inserts.
 - 5. Fastener systems.
 - 6. Pipe stands.
 - 7. Pipe positioning systems.
 - 8. Equipment supports.
- B. Related Sections include the following:
 - 1. Division 05 Section "Metal Fabrications" for structural-steel shapes and plates for trapeze hangers for pipe and equipment support.
 - 2. Division 21 Section "Water-Based Fire-Suppression Systems" for pipe hangers for fire-suppression piping.

1.03 DEFINITIONS

- A. MSS: Manufacturers Standardization Society for The Valve and Fittings Industry Inc.
- B. Terminology: As defined in MSS SP-90, "Guidelines on Terminology for Pipe Hangers and Supports.

1.04 PERFORMANCE REQUIREMENTS

- A. Design supports for multiple pipes, including pipe stands, capable of supporting combined weight of supported systems, system contents, and test water.
- B. Design equipment supports capable of supporting combined operating weight of supported equipment and connected systems and components.
- C. Design seismic-restraint hangers and supports for piping and equipment and obtain approval from authorities having jurisdiction.

1.05 SUBMITTALS

- A. Product Data: For the following:
 - 1. Steel pipe hangers and supports.
 - 2. Thermal-hanger shield inserts.
 - 3. Powder-actuated fastener systems.

- 4. Pipe positioning systems.
- B. Shop Drawings: Show fabrication and installation details and include calculations for the following:
 - 5. Trapeze pipe hangers. Include Product Data for components.
 - 6. Metal framing systems. Include Product Data for components.
 - 7. Pipe stands. Include Product Data for components.
 - 8. Equipment supports.
- D. Welding certificates.

1.06 QUALITY ASSURANCE

- A. Welding: Qualify procedures and personnel according to ASME Boiler and Pressure Vessel Code: Section IX.
- B. Welding: Qualify procedures and personnel according to the following:
 - 1. AWS D1.1, "Structural Welding Code--Steel."
 - 2. ASME Boiler and Pressure Vessel Code: Section IX.

PART 2-PRODUCTS

2.01 MANUFACTURERS

- A. In other Part 2 articles where titles below introduce lists, the following requirements apply to product selection:
 - 1. Manufacturers: Subject to compliance with requirements, provide products by one of the manufacturers specified.

2.02 STEEL PIPE HANGERS AND SUPPORTS

- A. Description: MSS SP-58, Types 1 through 58, factory-fabricated components. Refer to Part 3 "Hanger and Support Applications" Article for where to use specific hanger and support types.
- B. Available Manufacturers:
 - 1. AAA Technology & Specialties Co., Inc.
 - 2. B-Line Systems, Inc.; a division of Cooper Industries.
 - 3. Empire Industries, Inc.
 - 4. ERICO/Michigan Hanger Co.
 - 5. Globe Pipe Hanger Products, Inc.
 - 6. Grinnell Corp.
 - 7. Tolco Inc.
- C. Galvanized, Metallic Coatings: Pre-galvanized or hot dipped.
- D. Nonmetallic Coatings: Plastic coating, jacket, or liner.
- E. Padded Hangers: Hanger with fiberglass or other pipe insulation pad or cushion for support of bearing surface of piping.

2.03 TRAPEZE PIPE HANGERS

- A. Description: MSS SP-69, Type 59, shop- or field-fabricated pipe-support assembly made from structural-steel shapes with MSS SP-58 hanger rods, nuts, saddles, and U-bolts.

2.04 METAL FRAMING SYSTEMS

- A. Description: MFMA-3, shop- or field-fabricated pipe-support assembly made of steel channels and other components.
- B. Available Manufacturers:
 - 1. B-Line Systems, Inc.; a division of Cooper Industries.
 - 2. ERICO/Michigan Hanger Co.; ERISTRUT Div.
 - 3. GS Metals Corp.
 - 4. Power-Strut Div.; Tyco International, Ltd.
 - 5. Thomas & Betts Corporation.
 - 6. Tolco Inc.
 - 7. Unistrut Corp.; Tyco International, Ltd.
- C. Coatings: Manufacturer's standard finish unless bare metal surfaces are indicated.
- D. Nonmetallic Coatings: Plastic coating, jacket, or liner.

2.05 THERMAL-HANGER SHIELD INSERTS

- A. Description: 100-psig- minimum, compressive-strength insulation insert encased in sheet metal shield.
- B. Manufacturers:
 - 1. Carpenter & Paterson, Inc.
 - 2. ERICO/Michigan Hanger Co.
 - 3. PHS Industries, Inc.
 - 4. Pipe Shields, Inc.
 - 5. Rilco Manufacturing Company, Inc.
 - 6. Value Engineered Products, Inc.
- C. Insulation-Insert Material for Cold Piping: Water-repellent treated, ASTM C 533, Type I calcium silicate.
- D. Insulation-Insert Material for Hot Piping: Water-repellent treated, ASTM C 533, Type I calcium silicate.
- E. For Trapeze or Clamped Systems: Insert and shield shall cover entire circumference of pipe.
- F. For Clevis or Band Hangers: Insert and shield shall cover lower 180 degrees of pipe.
- G. Insert Length: Extend 2 inches beyond sheet metal shield for piping operating below ambient air temperature.

2.06 FASTENER SYSTEMS

- A. Powder-Actuated Fasteners: Threaded-steel stud, for use in hardened portland cement concrete with pull-out, tension, and shear capacities appropriate for supported loads and building materials where used.
 - 1. Manufacturers:
 - a. Hilti, Inc.
 - b. ITW Ramset/Red Head.
 - c. Masterset Fastening Systems, Inc.
 - d. MKT Fastening, LLC.

- e. Powers Fasteners.
- B. Mechanical-Expansion Anchors: Insert-wedge-type zinc-coated stainless steel, for use in hardened portland cement concrete with pull-out, tension, and shear capacities appropriate for supported loads and building materials where used.
 - 1. Manufacturers:
 - a. B-Line Systems, Inc.; a division of Cooper Industries.
 - b. Empire Industries, Inc.
 - c. Hilti, Inc.
 - d. ITW Ramset/Red Head.
 - e. MKT Fastening, LLC.
 - f. Powers Fasteners.

2.07 PIPE STAND FABRICATION

- A. Pipe Stands, General: Shop or field-fabricated assemblies made of manufactured corrosion-resistant components to support roof-mounted piping.
- B. Compact Pipe Stand: One-piece plastic unit with integral-rod-roller, pipe clamps, or V-shaped cradle to support pipe, for roof installation without membrane penetration.
 - 1. Manufacturers:
 - a. ERICO/Michigan Hanger Co.
 - b. MIRO Industries.
 - c. Low-Type, Single-Pipe Stand: One-piece plastic base unit with plastic roller, for roof installation without membrane penetration.
 - 2. Manufacturers:
 - a. MIRO Industries (or equal).
- C. High-Type, Single-Pipe Stand: Assembly of base, vertical and horizontal members, and pipe support, for roof installation without membrane penetration.
 - 1. Manufacturers:
 - a. ERICO/Michigan Hanger Co.
 - b. MIRO Industries.
 - c. Portable Pipe Hangers.
 - 2. Base: Plastic.
 - 3. Vertical Members: Two or more cadmium-plated-steel or stainless-steel, continuous-thread rods.
 - 4. Horizontal Member: Cadmium-plated-steel or stainless-steel rod with plastic or stainless-steel, roller-type pipe support.
- D. High-Type, Multiple-Pipe Stand: Assembly of bases, vertical and horizontal members, and pipe supports, for roof installation without membrane penetration.
 - 1. Manufacturers:
 - a. Portable Pipe Hangers.
 - 2. Bases: One or more plastic.
 - 3. Vertical Members: Two or more protective-coated-steel channels.
 - 4. Horizontal Member: Protective-coated-steel channel.
 - 5. Pipe Supports: Galvanized-steel, clevis-type pipe hangers.

- E. Curb-Mounting-Type Pipe Stands: Shop- or field-fabricated pipe support made from structural-steel shape, continuous-thread rods, and rollers for mounting on permanent stationary roof curb.

2.08 PIPE POSITIONING SYSTEMS

- A. Description: IAPMO PS 42, system of metal brackets, clips, and straps for positioning piping in pipe spaces for plumbing fixtures for commercial applications.
- B. Manufacturers:
 - 1. C & S Mfg. Corp.
 - 2. HOLDRITE Corp.; Hubbard Enterprises.
 - 3. Samco Stamping, Inc.

2.09 EQUIPMENT SUPPORTS

- A. Description: Welded, shop- or field-fabricated equipment support made from structural-steel shapes.
- B. Bracing shall be installed at all 90s and change in direction.

2.10 MISCELLANEOUS MATERIALS

- A. Structural Steel: ASTM A 36/A 36M, steel plates, shapes, and bars; black and galvanized.
- B. Grout: ASTM C 1107, factory-mixed and -packaged, dry, hydraulic-cement, non-shrink and nonmetallic grout; suitable for interior and exterior applications.
 - 1. Properties: Non-staining, noncorrosive, and nongaseous.
 - 2. Design Mix: 5000-psi, 28-day compressive strength.

PART 3-EXECUTION

3.02 HANGER AND SUPPORT APPLICATIONS

- A. Specific hanger and support requirements are specified in Sections specifying piping systems and equipment.
- B. Comply with MSS SP-69 for pipe hanger selections and applications that are not specified in piping system Sections.
- C. Use hangers and supports with galvanized, metallic coatings for piping and equipment that will not have field-applied finish.
- D. Use nonmetallic coatings on attachments for electrolytic protection where attachments are in direct contact with copper tubing.
- E. Use padded hangers for piping that is subject to scratching.
- F. Horizontal-Piping Hangers and Supports: Unless otherwise indicated and except as specified in piping system Sections, install the following types:
 - 1. Adjustable, Steel Clevis Hangers (MSS Type 1): For suspension of noninsulated or insulated stationary pipes, NPS 1/2 to NPS 30.
 - 2. Yoke-Type Pipe Clamps (MSS Type 2): For suspension of 120 to 450 deg F pipes, NPS 4 to NPS 16, requiring up to 4 inches of insulation.
 - 3. Carbon- or Alloy-Steel, Double-Bolt Pipe Clamps (MSS Type 3): For suspension of pipes, NPS 3/4 to NPS 24, requiring clamp flexibility and up to 4 inches of insulation.
 - 4. Steel Pipe Clamps (MSS Type 4): For suspension of cold and hot pipes, NPS 1/2 to NPS 24, if little or no insulation is required.

5. Pipe Hangers (MSS Type 5): For suspension of pipes, NPS 1/2 to NPS 4, to allow off-center closure for hanger installation before pipe erection.
 6. Adjustable, Swivel Split- or Solid-Ring Hangers (MSS Type 6): For suspension of non-insulated stationary pipes, NPS 3/4 to NPS 8.
 7. Adjustable, Steel Band Hangers (MSS Type 7): For suspension of non-insulated stationary pipes, NPS 1/2 to NPS 8.
 8. Adjustable Band Hangers (MSS Type 9): For suspension of noninsulated stationary pipes, NPS 1/2 to NPS 8.
 9. Adjustable, Swivel-Ring Band Hangers (MSS Type 10): For suspension of non-insulated stationary pipes, NPS 1/2 to NPS 2.
 10. Split Pipe-Ring with or without Turnbuckle-Adjustment Hangers (MSS Type 11): For suspension of non-insulated stationary pipes, NPS 3/8 to NPS 8.
 11. Extension Hinged or 2-Bolt Split Pipe Clamps (MSS Type 12): For suspension of non-insulated stationary pipes, NPS 3/8 to NPS 3.
 12. U-Bolts (MSS Type 24): For support of heavy pipes, NPS 1/2 to NPS 30.
 13. Clips (MSS Type 26): For support of insulated pipes not subject to expansion or contraction.
 14. Pipe Saddle Supports (MSS Type 36): For support of pipes, NPS 4 to NPS 36, with steel pipe base stanchion support and cast-iron floor flange.
 15. Pipe Stanchion Saddles (MSS Type 37): For support of pipes, NPS 4 to NPS 36, with steel pipe base stanchion support and cast-iron floor flange and with U-bolt to retain pipe.
 16. Adjustable, Pipe Saddle Supports (MSS Type 38): For stanchion-type support for pipes, NPS 2-1/2 to NPS 36, if vertical adjustment is required, with steel pipe base stanchion support and cast-iron floor flange.
 17. Single Pipe Rolls (MSS Type 41): For suspension of pipes, NPS 1 to NPS 30, from 2 rods if longitudinal movement caused by expansion and contraction might occur.
 18. Adjustable Roller Hangers (MSS Type 43): For suspension of pipes, NPS 2-1/2 to NPS 20, from single rod if horizontal movement caused by expansion and contraction might occur.
 19. Complete Pipe Rolls (MSS Type 44): For support of pipes, NPS 2 to NPS 42, if longitudinal movement caused by expansion and contraction might occur but vertical adjustment is not necessary.
 20. Pipe Roll and Plate Units (MSS Type 45): For support of pipes, NPS 2 to NPS 24, if small horizontal movement caused by expansion and contraction might occur and vertical adjustment is not necessary.
 21. Adjustable Pipe Roll and Base Units (MSS Type 46): For support of pipes, NPS 2 to NPS 30, if vertical and lateral adjustment during installation might be required in addition to expansion and contraction.
- G. Vertical-Piping Clamps: Unless otherwise indicated and except as specified in piping system Sections, install the following types:
1. Extension Pipe or Riser Clamps (MSS Type 8): For support of pipe risers, NPS 3/4 to NPS 20.
 2. Carbon- or Alloy-Steel Riser Clamps (MSS Type 42): For support of pipe risers, NPS 3/4 to NPS 20, if longer ends are required for riser clamps.
- H. Hanger-Rod Attachments: Unless otherwise indicated and except as specified in piping system Sections, install the following types:

1. Steel Turnbuckles (MSS Type 13): For adjustment up to 6 inches for heavy loads.
 2. Steel Clevises (MSS Type 14): For 120 to 450 deg F piping installations.
 3. Swivel Turnbuckles (MSS Type 15): For use with MSS Type 11, split pipe rings.
 4. Malleable-Iron Sockets (MSS Type 16): For attaching hanger rods to various types of building attachments.
 5. Steel Weldless Eye Nuts (MSS Type 17): For 120 to 450 deg F piping installations.
- I. Building Attachments: Unless otherwise indicated and except as specified in piping system Sections, install the following types:
1. Steel or Malleable Concrete Inserts (MSS Type 18): For upper attachment to suspend pipe hangers from concrete ceiling.
 2. Top-Beam C-Clamps (MSS Type 19): For use under roof installations with bar-joint construction to attach to top flange of structural shape.
 3. Side-Beam or Channel Clamps (MSS Type 20): For attaching to bottom flange of beams, channels, or angles.
 4. Center-Beam Clamps (MSS Type 21): For attaching to center of bottom flange of beams.
 5. Welded Beam Attachments (MSS Type 22): For attaching to bottom of beams if loads are considerable and rod sizes are large.
 6. C-Clamps (MSS Type 23): For structural shapes.
 7. Top-Beam Clamps (MSS Type 25): For top of beams if hanger rod is required tangent to flange edge.
 8. Side-Beam Clamps (MSS Type 27): For bottom of steel I-beams.
 9. Steel-Beam Clamps with Eye Nuts (MSS Type 28): For attaching to bottom of steel I-beams for heavy loads.
 10. Linked-Steel Clamps with Eye Nuts (MSS Type 29): For attaching to bottom of steel I-beams for heavy loads, with link extensions.
 11. Malleable Beam Clamps with Extension Pieces (MSS Type 30): For attaching to structural steel.
 12. Welded-Steel Brackets: For support of pipes from below, or for suspending from above by using clip and rod. Use one of the following for indicated loads:
 - a. Light (MSS Type 31): 750 lb.
 - b. Medium (MSS Type 32): 1500 lb.
 - c. Heavy (MSS Type 33): 3000 lb.
 13. Side-Beam Brackets (MSS Type 34): For sides of steel or wooden beams.
 14. Plate Lugs (MSS Type 57): For attaching to steel beams if flexibility at beam is required.
 15. Horizontal Travelers (MSS Type 58): For supporting piping systems subject to linear horizontal movement where headroom is limited.
- J. Saddles and Shields: Unless otherwise indicated and except as specified in piping system Sections, install the following types:
1. Steel Pipe-Covering Protection Saddles (MSS Type 39): To fill interior voids with insulation that matches adjoining insulation.
 2. Protection Shields (MSS Type 40): Of length recommended in writing by manufacturer to prevent crushing insulation.
 3. Thermal-Hanger Shield Inserts: For supporting insulated pipe.

- K. Spring Hangers and Supports: Unless otherwise indicated and except as specified in piping system Sections, install the following types:
1. Restraint-Control Devices (MSS Type 47): Where indicated to control piping movement.
 2. Spring Cushions (MSS Type 48): For light loads if vertical movement does not exceed 1-1/4 inches.
 3. Spring-Cushion Roll Hangers (MSS Type 49): For equipping Type 41 roll hanger with springs.
 4. Spring Sway Braces (MSS Type 50): To retard sway, shock, vibration, or thermal expansion in piping systems.
 5. Variable-Spring Hangers (MSS Type 51): Preset to indicated load and limit variability factor to 25 percent to absorb expansion and contraction of piping system from hanger.
 6. Variable-Spring Base Supports (MSS Type 52): Preset to indicated load and limit variability factor to 25 percent to absorb expansion and contraction of piping system from base support.
 7. Variable-Spring Trapeze Hangers (MSS Type 53): Preset to indicated load and limit variability factor to 25 percent to absorb expansion and contraction of piping system from trapeze support.
 8. Constant Supports: For critical piping stress and if necessary to avoid transfer of stress from one support to another support, critical terminal, or connected equipment. Include auxiliary stops for erection, hydrostatic test, and load-adjustment capability. These supports include the following types:
 - a. Horizontal (MSS Type 54): Mounted horizontally.
 - b. Vertical (MSS Type 55): Mounted vertically.
 - c. Trapeze (MSS Type 56): Two vertical-type supports and one trapeze member.
- L. Comply with MSS SP-69 for trapeze pipe hanger selections and applications that are not specified in piping system Sections.
- M. Comply with MFMA-102 for metal framing system selections and applications that are not specified in piping system Sections.
- N. Use mechanical-expansion anchors instead of building attachments where required in concrete construction.
- O. Use pipe positioning systems in pipe spaces behind plumbing fixtures to support supply and waste piping for plumbing fixtures.

3.02 HANGER AND SUPPORT INSTALLATION

- A. Steel Pipe Hanger Installation: Comply with MSS SP-69 and MSS SP-89. Install hangers, supports, clamps, and attachments as required to properly support piping from building structure.
- B. Trapeze Pipe Hanger Installation: Comply with MSS SP-69 and MSS SP-89. Arrange for grouping of parallel runs of horizontal piping and support together on field-fabricated trapeze pipe hangers.
1. Pipes of Various Sizes: Support together and space trapezes for smallest pipe size or install intermediate supports for smaller diameter pipes as specified above for individual pipe hangers.
 2. Field fabricate from ASTM A 36/A 36M, steel shapes selected for loads being supported. Weld steel according to AWS D1.1.

- C. Fiberglass Pipe Hanger Installation: Comply with applicable portions of MSS SP-69 and MSS SP-89. Install hangers and attachments as required to properly support piping from building structure.
- D. Metal Framing System Installation: Arrange for grouping of parallel runs of piping and support together on field-assembled metal framing systems.
- E. Fiberglass Strut System Installation: Arrange for grouping of parallel runs of piping and support together on field-assembled fiberglass struts.
- F. Thermal-Hanger Shield Installation: Install in pipe hanger or shield for insulated piping.
- G. Fastener System Installation:
 - 1. Install powder-actuated fasteners for use in lightweight concrete or concrete slabs less than 4 inches thick in concrete after concrete is placed and completely cured. Use operators that are licensed by powder-actuated tool manufacturer. Install fasteners according to powder-actuated tool manufacturer's operating manual.
 - 2. Install mechanical-expansion anchors in concrete after concrete is placed and completely cured. Install fasteners according to manufacturer's written instructions.
- H. Pipe Stand Installation:
 - 1. Pipe Stand Types except Curb-Mounting Type: Assemble components and mount on smooth roof surface. Do not penetrate roof membrane.
 - 2. Curb-Mounting-Type Pipe Stands: Assemble components or fabricate pipe stand and mount on permanent, stationary roof curb. Refer to Division 07 Section "Roof Accessories" for curbs.
- I. Pipe Positioning System Installation: Install support devices to make rigid supply and waste piping connections to each plumbing fixture. Refer to Division 22 Section "Plumbing Fixtures" for plumbing fixtures.
- J. Install hangers and supports complete with necessary inserts, bolts, rods, nuts, washers, and other accessories.
- K. Equipment Support Installation: Fabricate from welded-structural-steel shapes.
- L. Install hangers and supports to allow controlled thermal and seismic movement of piping systems, to permit freedom of movement between pipe anchors, and to facilitate action of expansion joints, expansion loops, expansion bends, and similar units.
- M. Install lateral bracing with pipe hangers and supports to prevent swaying.
- N. Install building attachments within concrete slabs or attach to structural steel. Install additional attachments at concentrated loads, including valves, flanges, and strainers, NPS 2-1/2 and larger and at changes in direction of piping. Install concrete inserts before concrete is placed; fasten inserts to forms and install reinforcing bars through openings at top of inserts.
- O. Load Distribution: Install hangers and supports so piping live and dead loads and stresses from movement will not be transmitted to connected equipment.
- P. Pipe Slopes: Install hangers and supports to provide indicated pipe slopes and so maximum pipe deflections allowed by ASME B31.9 (for building services piping) are not exceeded.
- Q. Insulated Piping: Comply with the following:
 - 1. Attach clamps and spacers to piping.
 - a. Piping Operating above Ambient Air Temperature: Clamp may project through insulation.

- b. Piping Operating below Ambient Air Temperature: Use thermal-hanger shield insert with clamp sized to match OD of insert.
 - c. Do not exceed pipe stress limits according to ASME B31.9 for building services piping.
2. Install MSS SP-58, Type 39, protection saddles if insulation without vapor barrier is indicated. Fill interior voids with insulation that matches adjoining insulation.
 - a. Option: Thermal-hanger shield inserts may be used. Include steel weight-distribution plate for pipe NPS 4 and larger if pipe is installed on rollers.
3. Install MSS SP-58, Type 40, protective shields on cold piping with vapor barrier. Shields shall span an arc of 180 degrees.
 - a. Option: Thermal-hanger shield inserts may be used. Include steel weight-distribution plate for pipe NPS 4 and larger if pipe is installed on rollers.
4. Shield Dimensions for Pipe: Not less than the following:
 - a. NPS 1/4 to NPS 3-1/2: 12 inches long and 0.048 inch thick.
 - b. NPS 4: 12 inches long and 0.06 inch thick.
 - c. NPS 5 and NPS 6: 18 inches long and 0.06 inch thick.
 - d. NPS 8 to NPS 14: 24 inches long and 0.075 inch thick.
 - e. NPS 16 to NPS 24: 24 inch long and 0.105 inch thick.
5. Pipes NPS 8 and Larger: Include wood inserts.
6. Insert Material: Length at least as long as protective shield.
7. Thermal-Hanger Shields: Install with insulation same thickness as piping insulation.

3.03 EQUIPMENT SUPPORTS

- A. Fabricate structural-steel stands to suspend equipment from structure overhead or to support equipment above floor.
- B. Grouting: Place grout under supports for equipment and make smooth bearing surface.
- C. Provide lateral bracing, to prevent swaying, for equipment supports.

3.04 METAL FABRICATIONS

- A. Cut, drill, and fit miscellaneous metal fabrications for trapeze pipe hangers and equipment supports.
- B. Fit exposed connections together to form hairline joints. Field weld connections that cannot be shop welded because of shipping size limitations.
- C. Field Welding: Comply with AWS D1.1 procedures for shielded metal arc welding, appearance and quality of welds, and methods used in correcting welding work, and with the following:
 1. Use materials and methods that minimize distortion and develop strength and corrosion resistance of base metals.
 2. Obtain fusion without undercut or overlap.
 3. Remove welding flux immediately.
 4. Finish welds at exposed connections so no roughness shows after finishing and contours of welded surfaces match adjacent contours.

3.05 ADJUSTING

- A. Hanger Adjustments: Adjust hangers to distribute loads equally on attachments and to achieve indicated slope of pipe.
- B. Trim excess length of continuous-thread hanger and support rods to 1-1/2 inches.

3.06 PAINTING

- A. Touch Up: Clean field welds and abraded areas of shop paint. Paint exposed areas immediately after erecting hangers and supports. Use same materials as used for shop painting. Comply with SSPC-PA 1 requirements for touching up field-painted surfaces.
 - 1. Apply paint by brush or spray to provide minimum dry film thickness of 2.0 mils.
- B. Touch Up: Cleaning and touchup painting of field welds, bolted connections, and abraded areas of shop paint on miscellaneous metal are specified in Division 09 painting Sections.
- C. Galvanized Surfaces: Clean welds, bolted connections, and abraded areas and apply galvanizing-repair paint to comply with ASTM A 780.

END OF SECTION

SECTION 220553 - IDENTIFICATION FOR PLUMBING PIPING AND EQUIPMENT

PART 1- GENERAL

1.01 RELATED DOCUMENTS

- A. Drawings and general provisions of the Contract, including General and Supplementary Conditions and Division 01 Specification Sections, apply to this Section.

1.02 SUMMARY

- A. Section Includes:
 - 1. Equipment labels.
 - 2. Warning signs and labels.
 - 3. Pipe labels.
 - 4. Stencils.
 - 5. Valve tags.
 - 6. Warning tags.

1.03 SUBMITTALS

- A. Product Data: For each type of product indicated.
- B. Samples: For color, letter style, and graphic representation required for each identification material and device.
- C. Equipment Label Schedule: Include a listing of all equipment to be labeled with the proposed content for each label.
- D. Valve numbering scheme.
- E. Valve Schedules: For each piping system to include in maintenance manuals.

1.04 COORDINATION

- A. Coordinate installation of identifying devices with completion of covering and painting of surfaces where devices are to be applied.
- B. Coordinate installation of identifying devices with locations of access panels and doors.
- C. Install identifying devices before installing acoustical ceilings and similar concealment.
- D. The new plant piping colors shall match the existing colors, if painted. A schedule shall be posted in the plant that lists paint designations.
- E. All piping and valves should be marked with a stamped or engraved (NOT painted or hand lettered) brass metal tag secured with a flexible chain or cable.

PART 2 –PRODUCTS

2.01 EQUIPMENT LABELS

- A. Metal Labels for Equipment:

1. Material and Thickness: Brass, 0.032-inch minimum thickness, and having predrilled or stamped holes for attachment hardware.
 2. Minimum Label Size: Length and width vary for required label content, but not less than 2-1/2 by 3/4 inch.
 3. Minimum Letter Size: 1/4 inch for name of units if viewing distance is less than 24 inches, 1/2 inch for viewing distances up to 72 inches, and proportionately larger lettering for greater viewing distances. Include secondary lettering two-thirds to three-fourths the size of principal lettering.
 4. Fasteners: Stainless-steel rivets or self-tapping screws.
 5. Adhesive: Contact-type permanent adhesive, compatible with label and with substrate.
- B. Plastic Labels for Equipment:
1. Material and Thickness: Multilayer, multicolor, plastic labels for mechanical engraving, 1/8 inch thick, and having predrilled holes for attachment hardware.
 2. Letter Color: White.
 3. Background Color: Black.
 4. Maximum Temperature: Able to withstand temperatures up to 160 deg F.
 5. Minimum Label Size: Length and width vary for required label content, but not less than 2-1/2 by 3/4 inch.
 6. Minimum Letter Size: 1/4 inch for name of units if viewing distance is less than 24 inches, 1/2 inch for viewing distances up to 72 inches, and proportionately larger lettering for greater viewing distances. Include secondary lettering two-thirds to three-fourths the size of principal lettering.
 7. Fasteners: Stainless-steel self-tapping screws.
 8. Adhesive: Contact-type permanent adhesive, compatible with label and with substrate.
- C. Label Content: Include equipment's Drawing designation or unique equipment number, Drawing numbers where equipment is indicated (plans, details, and schedules), plus the Specification Section number and title where equipment is specified.
- D. Equipment Label Schedule: For each item of equipment to be labeled, on 8-1/2-by-11-inch bond paper. Tabulate equipment identification number and identify Drawing numbers where equipment is indicated (plans, and schedules), plus the Specification Section number and title where equipment is specified. Equipment schedule shall be included in operation and maintenance data.

2.02 WARNING SIGNS AND LABELS

- A. Material and Thickness: Multilayer, multicolor, plastic labels for mechanical engraving, 1/8 inch thick, and having predrilled holes for attachment hardware.
- B. Letter Color: White.
- C. Background Color: Red.
- D. Maximum Temperature: Able to withstand temperatures up to 160 deg F.
- E. Minimum Label Size: Length and width vary for required label content, but not less than 2-1/2 by 3/4 inch.

- F. Minimum Letter Size: 1/4 inch for name of units if viewing distance is less than 24 inches, 1/2 inch for viewing distances up to 72 inches, and proportionately larger lettering for greater viewing distances. Include secondary lettering two-thirds to three-fourths the size of principal lettering.
- G. Fasteners: Stainless-steel self-tapping screws.
- H. Adhesive: Contact-type permanent adhesive, compatible with label and with substrate.
- I. Label Content: Include caution and warning information, plus emergency notification instructions.
- J. The ceiling grid shall be marked with plaques that designate the location of all isolation and emergency shut-off valves, resettable fire and smoke dampers, and other equipment that requires quick access in an emergency.

2.03 PIPE LABELS

- A. All piping shall be appropriately marked by the contractor with a stamped or engraved (NOT painted or hand-lettered) brass metal tag secured with a flexible chain or cable.
- B. General Requirements for Manufactured Pipe Labels: Preprinted, color-coded, with lettering indicating service, and showing flow direction.
- C. Pre-tensioned Pipe Labels: Pre-coiled, semi-rigid plastic formed to cover full circumference of pipe and to attach to pipe without fasteners or adhesive.
- D. Self-Adhesive Pipe Labels: Printed plastic with contact-type, permanent-adhesive backing.
- E. Pipe Label Contents: Include identification of piping service using same designations or abbreviations as used on Drawings, pipe size, and an arrow indicating flow direction.
 - 1. Flow-Direction Arrows: Integral with piping system service lettering to accommodate both directions, or as separate unit on each pipe label to indicate flow direction.
 - 2. Lettering Size: At least 1-1/2 inches high.

2.04 STENCILS

- A. Stencils: Prepared with letter sizes according to ASME A13.1 for piping; and minimum letter height of 3/4 inch for access panel and door labels, equipment labels, and similar operational instructions.
 - 1. Stencil Material: Fiberboard or metal.
 - 2. Stencil Paint: Exterior, gloss, acrylic enamel black unless otherwise indicated. Paint may be in pressurized spray-can form.
 - 3. Identification Paint: Exterior, acrylic enamel in colors according to ASME A13.1 unless otherwise indicated.

2.05 VALVE TAGS

- A. Valve Tags: Stamped or engraved with 1/4-inch letters for piping system abbreviation and 1/2-inch (13-mm) numbers.

1. Tag Material: Brass, 0.032-inch Stainless steel, 0.025-inch Aluminum, 0.032-inch or anodized aluminum, 0.032-inch minimum thickness, and having predrilled or stamped holes for attachment hardware.
 2. Fasteners: Brass wire-link or beaded chain; or S-hook wire-link chain beaded chain S-hook.
- B. Valve Schedules: For each piping system, on 8-1/2-by-11-inch bond paper. Tabulate valve number, piping system, system abbreviation (as shown on valve tag), location of valve (room or space), normal-operating position (open, closed, or modulating), and variations for identification. Mark valves for emergency shutoff and similar special uses.
1. Valve-tag schedule shall be included in operation and maintenance data.

2.05 WARNING TAGS

- A. Warning Tags: Preprinted or partially preprinted, accident-prevention tags, of plasticized card stock with matte finish suitable for writing.
1. Size: 3 by 5-1/4 inches minimum.
 2. Fasteners: Reinforced grommet and wire or string.
 3. Nomenclature: Large-size primary caption such as "DANGER," "CAUTION," or "DO NOT OPERATE."
 4. Color: Yellow background with black lettering.

PART 3 - EXECUTION

3.01 PREPARATION

- A. Clean piping and equipment surfaces of substances that could impair bond of identification devices, including dirt, oil, grease, release agents, and incompatible primers, paints, and encapsulants.

3.02 EQUIPMENT LABEL INSTALLATION

- A. Install or permanently fasten labels on each major item of mechanical equipment.
- B. Locate equipment labels where accessible and visible.

3.03 PIPE LABEL INSTALLATION

- A. Piping Color-Coding: Painting of piping is specified in Division 09.
- B. Stenciled Pipe Label Option: Stenciled labels may be provided instead of manufactured pipe labels, at Installer's option. Install stenciled pipe labels color-coded bands or rectangles complying with ASME A13.1 on each piping system.
 1. Identification Paint: Use for contrasting background.
 2. Stencil Paint: Use for pipe marking.
- C. Locate pipe labels where piping is exposed or above accessible ceilings in finished spaces; machine rooms; accessible maintenance spaces such as shafts, tunnels, and plenums; and exterior exposed locations as follows:
 1. Near each valve and control device.

2. Near each branch connection, excluding short takeoffs for fixtures and terminal units. Where flow pattern is not obvious, mark each pipe at branch.
 3. Near penetrations through walls, floors, ceilings, and inaccessible enclosures.
 4. At access doors, manholes, and similar access points that permit view of concealed piping.
 5. Near major equipment items and other points of origination and termination.
 6. Spaced at maximum intervals of 50 feet along each run. Reduce intervals to 25 feet in areas of congested piping and equipment.
 7. On piping above removable acoustical ceilings. Omit intermediately spaced labels.
- D. Pipe Label Color Schedule:
1. Low-Pressure, Compressed-Air Piping:
 - a. Background Color: Yellow.
 - b. Letter Color: Black.
 2. Domestic Water Piping:
 - a. Background Color: Blue.
 - b. Letter Color: Black.
 3. Sanitary Waste and Storm Drainage Piping:
 - a. Background Color: Blue.
 - b. Letter Color: White.

3.04 VALVE-TAG INSTALLATION

- A. Install tags on valves and control devices in piping systems, except check valves; valves within factory-fabricated equipment units; shutoff valves; faucets; convenience and lawn-watering hose connections; and similar roughing-in connections of end-use fixtures and units. List tagged valves in a valve schedule.
- B. Valve-Tag Application Schedule: Tag valves according to size, shape, and color scheme and with captions similar to those indicated in the following subparagraphs:
1. Valve-Tag Size and Shape:
 - a. Cold Water: 1-1/2 inches, round.
 - b. Hot Water: 1-1/2 inches, round.
 - c. Low-Pressure Compressed Air: 1-1/2 inches, round.
 2. Valve-Tag Color:
 - a. Cold Water: Natural.
 - b. Hot Water: Natural.
 - c. Low-Pressure Compressed Air: Natural.
 3. Letter Color:
 - a. Cold Water: Black.
 - b. Hot Water: Black.
 - c. Low-Pressure Compressed Air: Black.

3.05 WARNING-TAG INSTALLATION

- A. Write required message on, and attach warning tags to, equipment and other items where required.

END OF SECTION

SECTION 220700 - PLUMBING INSULATION

PART 1 - GENERAL

1.01 RELATED DOCUMENTS

- A. Drawings and general provisions of the Contract, including General and Supplementary Conditions and Division 01 Specification Sections, apply to this Section.

1.02 SUMMARY

- A. Section Includes:
 - 1. Insulation Materials:
 - a. Cellular glass.
 - b. Flexible elastomeric.
 - c. Mineral fiber.
 - d. Phenolic.
 - 2. Insulating cements.
 - 3. Adhesives.
 - 4. Mastics.
 - 5. Lagging adhesives.
 - 6. Sealants.
 - 7. Factory-applied jackets.
 - 8. Field-applied jackets.
 - 9. Tapes.
 - 10. Securements.
 - 11. Corner angles.
- B. Related Sections include the following:
 - 1. Division 23 Section "HVAC Insulation."

1.03 SUBMITTALS

- A. Product Data: For each type of product indicated. Include thermal conductivity, thickness, and jackets (both factory and field applied, if any).
- B. LEED Submittal:
 - 1. Product Data for Credit EQ 4.1: For adhesives and sealants, including printed statement of VOC content.
- C. Shop Drawings:
 - 1. Detail application of protective shields, saddles, and inserts at hangers for each type of insulation and hanger.
 - 2. Detail attachment and covering of heat tracing inside insulation.
 - 3. Detail insulation application at pipe expansion joints for each type of insulation.
 - 4. Detail insulation application at elbows, fittings, flanges, valves, and specialties for each type of insulation.

5. Detail removable insulation at piping specialties, equipment connections, and access panels.
 6. Detail application of field-applied jackets.
 7. Detail application at linkages of control devices.
 8. Detail field application for each equipment type.
- D. Samples: For each type of insulation and jacket indicated. Identify each Sample, describing product and intended use. Sample sizes are as follows:
1. Sample Sizes:
 - a. Preformed Pipe Insulation Materials: 12 inches long by NPS 2.
 - b. Sheet Form Insulation Materials: 12 inches square.
 - c. Jacket Materials for Pipe: 12 inches long by NPS 2.
 - d. Sheet Jacket Materials: 12 inches square.
 - e. Manufacturer's Color Charts: For products where color is specified, show the full range of colors available for each type of finish material.
- E. Qualification Data: For qualified Installer.
- F. Material Test Reports: From a qualified testing agency acceptable to authorities having jurisdiction indicating, interpreting, and certifying test results for compliance of insulation materials, sealers, attachments, cements, and jackets, with requirements indicated. Include dates of tests and test methods employed.
- G. Field quality-control reports.

1.04 QUALITY ASSURANCE

- A. Installer Qualifications: Skilled mechanics who have successfully completed an apprenticeship program or another craft training program certified by the Department of Labor, Bureau of Apprenticeship and Training.
- B. Fire-Test-Response Characteristics: Insulation and related materials shall have fire-test-response characteristics indicated, as determined by testing identical products per ASTM E 84, by a testing and inspecting agency acceptable to authorities having jurisdiction. Factory label insulation and jacket materials and adhesive, mastic, tapes, and cement material containers, with appropriate markings of applicable testing and inspecting agency.
1. Insulation Installed Indoors: Flame-spread index of 25 or less, and smoke-developed index of 50 or less.
 2. Insulation Installed Outdoors: Flame-spread index of 75 or less, and smoke-developed index of 150 or less.
- C. Mockups: Before installing insulation, build mockups for each type of insulation and finish listed below to demonstrate quality of insulation application and finishes. Build mockups in the location indicated or, if not indicated, as directed by Architect. Use materials indicated for the completed Work.
1. Piping Mockups:
 - a. One 10-foot section of NPS 2 straight pipe.
 - b. One each of a 90-degree threaded, welded, and flanged elbow.
 - c. One each of a threaded, welded, and flanged tee fitting.
 - d. One NPS 2 or smaller valve, and one NPS 2-1/2 or larger valve.

- e. Four support hangers including hanger shield and insert.
 - f. One threaded strainer and one flanged strainer with removable portion of insulation.
 - g. One threaded reducer and one welded reducer.
 - h. One pressure temperature tap.
 - i. One mechanical coupling.
2. Equipment Mockups: One tank or vessel.
 3. For each mockup, fabricate cutaway sections to allow observation of application details for insulation materials, adhesives, mastics, attachments, and jackets.
 4. Notify Architect seven days in advance of dates and times when mockups will be constructed.
 5. Obtain Architect's approval of mockups before starting insulation application.
 6. Approval of mockups does not constitute approval of deviations from the Contract Documents contained in mockups unless Architect specifically approves such deviations in writing.
 7. Maintain mockups during construction in an undisturbed condition as a standard for judging the completed Work.
 8. Demolish and remove mockups when directed.

1.05 DELIVERY, STORAGE, AND HANDLING

- A. Packaging: Insulation material containers shall be marked by manufacturer with appropriate ASTM standard designation, type and grade, and maximum use temperature.

1.06 COORDINATION

- A. Coordinate size and location of supports, hangers, and insulation shields specified in Division 22 Section "Hangers and Supports for Plumbing Piping and Equipment."
- B. Coordinate clearance requirements with piping Installer for piping insulation application and equipment Installer for equipment insulation application. Before preparing piping Shop Drawings, establish and maintain clearance requirements for installation of insulation and field-applied jackets and finishes and for space required for maintenance.
- C. Coordinate installation and testing of heat tracing.

1.07 SCHEDULING

- A. Schedule insulation application after pressure testing systems and, where required, after installing and testing heat tracing. Insulation application may begin on segments that have satisfactory test results.
- B. Complete installation and concealment of plastic materials as rapidly as possible in each area of construction.

PART 2 – PRODUCTS

2.01 INSULATION MATERIALS

- A. Manufacturer: Subject to compliance with requirements, provide products of one of the following:
 1. Armstrong World Industries, Inc.
 2. Certainteed Corp.

3. Knauf Fiber Glass GmbH.
 4. Owens-Corning Fiberglas Corp.
 5. Pittsburgh Corning Corp.
 6. FGH Fabricators, Inc.
- B. Adhesives shall be as manufactured by Minnesota Mining, Arabol, Benjamin-Foster, Armstrong, or Insulmastic, Inc., and shall have the same adhesive properties, fire rating, vapor seal, etc., as the types specified herein, subject to review by the Engineer.

2.02 PIPING INSULATION MATERIALS

- A. Fiberglass Piping Insulation: ASTM C 547, Class 1 unless otherwise indicated. (Indoor locations)
- B. Jackets for Piping Insulation: ASTM C 921, Type I (vapor barrier) for piping with temperatures below ambient, Type II (water vapor permeable) for piping with temperatures above ambient. Type I may be used for all piping at Installers option.
1. Encase pipe fittings insulation with one-piece pre-molded 16 MIL aluminum fitting covers, fastened as per manufacturer's recommendations.
 2. Encase exterior piping insulation with 16 MIL aluminum jacket with "Z" closures for weather-proof construction.
- C. Staples, Bands, Wires, and Cement: As recommended by insulation manufacturer for applications indicated.
- D. Adhesives, Sealers, and Protective Finishes: As recommended by insulation manufacturer for applications indicated. White all service jacket "ASJ" vapor barrier with dual self-seal strips for all insulation except flexible unicellular.

2.03 INSULATING CEMENTS

- A. Mineral-Fiber Insulating Cement: Comply with ASTM C 195.
1. Products: Subject to compliance with requirements, provide one of the following:
 - a. Insulco, Division of MFS, Inc.; Triple I.
 - b. P. K. Insulation Mfg. Co., Inc.; Super-Stik.
- B. Expanded or Exfoliated Vermiculite Insulating Cement: Comply with ASTM C 196.
1. Products: Subject to compliance with requirements, provide one of the following:
 - a. P. K. Insulation Mfg. Co., Inc.; Thermal-V-Kote.
- C. Mineral-Fiber, Hydraulic-Setting Insulating and Finishing Cement: Comply with ASTM C 449/C 449M.
1. Products: Subject to compliance with requirements, provide one of the following:
 - a. Insulco, Division of MFS, Inc.; SmoothKote.
 - b. P. K. Insulation Mfg. Co., Inc.; PK No. 127, and Quik-Cote.
 - c. Rock Wool Manufacturing Company; Delta One Shot.

2.04 ADHESIVES

- A. Materials shall be compatible with insulation materials, jackets, and substrates and for bonding insulation to itself and to surfaces to be insulated, unless otherwise indicated.

- B. Cellular-Glass, Phenolic, Polyisocyanurate, and Polystyrene Adhesive: Solvent-based resin adhesive, with a service temperature range of minus 75 to plus 300 deg F.
 - 1. Products: Subject to compliance with requirements, provide one of the following:
 - a. Childers Products, Division of ITW; CP-96.
 - b. Foster Products Corporation, H. B. Fuller Company; 81-33.
 - 2. For indoor applications, use adhesive that has a VOC content of 50 g/L or less when calculated according to 40 CFR 59, Subpart D (EPA Method 24).
- C. Flexible Elastomeric and Polyolefin Adhesive: Comply with MIL-A-24179A, Type II, Class I.
 - 1. Products: Subject to compliance with requirements, provide one of the following:
 - a. Aeroflex USA Inc.; Aeroseal.
 - b. Armacell LCC; 520 Adhesive.
 - c. Foster Products Corporation, H. B. Fuller Company; 85-75.
 - d. RBX Corporation; Rubatex Contact Adhesive.
 - 2. For indoor applications, use adhesive that has a VOC content of 50 g/L or less when calculated according to 40 CFR 59, Subpart D (EPA Method 24).
- D. Mineral-Fiber Adhesive: Comply with MIL-A-3316C, Class 2, Grade A.
 - 1. Products: Subject to compliance with requirements, provide one of the following:
 - a. Childers Products, Division of ITW; CP-82.
 - b. Foster Products Corporation, H. B. Fuller Company; 85-20.
 - c. ITW TACC, Division of Illinois Tool Works; S-90/80.
 - d. Marathon Industries, Inc.; 225.
 - e. Mon-Eco Industries, Inc.; 22-25.
 - 2. For indoor applications, use adhesive that has a VOC content of 80 g/L or less when calculated according to 40 CFR 59, Subpart D (EPA Method 24).
- E. Polystyrene Adhesive: Solvent- or water-based, synthetic resin adhesive with a service temperature range of minus 20 to plus 140 deg F.
 - 1. Products: Subject to compliance with requirements, provide one of the following:
 - a. Childers Products, Division of ITW; CP-96.
 - b. Foster Products Corporation, H. B. Fuller Company; 97-13.
- F. ASJ Adhesive, and FSK and PVDC Jacket Adhesive: Comply with MIL-A-3316C, Class 2, Grade A for bonding insulation jacket lap seams and joints.
 - 1. Products: Subject to compliance with requirements, provide one of the following:
 - a. Childers Products, Division of ITW; CP-82.
 - b. Foster Products Corporation, H. B. Fuller Company; 85-20.
 - c. ITW TACC, Division of Illinois Tool Works; S-90/80.
 - d. Marathon Industries, Inc.; 225.
 - e. Mon-Eco Industries, Inc.; 22-25.
 - 2. For indoor applications, use adhesive that has a VOC content of 50 g/L or less when calculated according to 40 CFR 59, Subpart D (EPA Method 24).
- G. PVC Jacket Adhesive: Compatible with PVC jacket.
 - 1. Products: Subject to compliance with requirements, provide one of the following:

- a. Dow Chemical Company (The); 739, Dow Silicone.
 - b. Johns-Manville; Zeston Perma-Weld, CEEL-TITE Solvent Welding Adhesive.
 - c. P.I.C. Plastics, Inc.; Welding Adhesive.
 - d. Speedline Corporation; Speedline Vinyl Adhesive.
2. For indoor applications, use adhesive that has a VOC content of 50 g/L or less when calculated according to 40 CFR 59, Subpart D (EPA Method 24).

2.05 MASTICS

- A. Materials shall be compatible with insulation materials, jackets, and substrates; comply with MIL-C-19565C, Type II.
- B. Vapor-Barrier Mastic: Water based; suitable for indoor and outdoor use on below ambient services.
 1. Products: Subject to compliance with requirements, provide one of the following:
 - a. Childers Products, Division of ITW; CP-35.
 - b. Foster Products Corporation, H. B. Fuller Company; 30-90.
 - c. ITW TACC, Division of Illinois Tool Works; CB-50.
 - d. Marathon Industries, Inc.; 590.
 - e. Mon-Eco Industries, Inc.; 55-40.
 - f. Vimasco Corporation; 749.
 2. Water-Vapor Permeance: ASTM E 96, Procedure B, 0.013 perm at 43-mil dry film thickness.
 3. Service Temperature Range: Minus 20 to plus 180 deg F.
 4. Solids Content: ASTM D 1644, 59 percent by volume and 71 percent by weight.
 5. Color: White.
- C. Vapor-Barrier Mastic: Solvent based; suitable for indoor use on below ambient services.
 1. Products: Subject to compliance with requirements, provide one of the following:
 - a. Childers Products, Division of ITW; CP-30.
 - b. Foster Products Corporation, H. B. Fuller Company; 30-35.
 - c. ITW TACC, Division of Illinois Tool Works; CB-25.
 - d. Marathon Industries, Inc.; 501.
 - e. Mon-Eco Industries, Inc.; 55-10.
 2. Water-Vapor Permeance: ASTM F 1249, 0.05 perm at 35-mil dry film thickness.
 3. Service Temperature Range: 0 to 180 deg F.
 4. Solids Content: ASTM D 1644, 44 percent by volume and 62 percent by weight.
 5. Color: White.
- D. Vapor-Barrier Mastic: Solvent based; suitable for outdoor use on below ambient services.
 1. Products: Subject to compliance with requirements, provide the following:
 - a. Childers Products, Division of ITW; Encacel.
 - b. Foster Products Corporation, H. B. Fuller Company; 60-95/60-96.
 - c. Marathon Industries, Inc.; 570.
 - d. Mon-Eco Industries, Inc.; 55-70.

2. Water-Vapor Permeance: ASTM F 1249, 0.05 perm at 30-mil dry film thickness.
 3. Service Temperature Range: Minus 50 to plus 220 deg F.
 4. Solids Content: ASTM D 1644, 33 percent by volume and 46 percent by weight.
 5. Color: White.
- E. Breather Mastic: Water based; suitable for indoor and outdoor use on above ambient services.
1. Products: Subject to compliance with requirements, provide the following:
 - a. Childers Products, Division of ITW; CP-10.
 - b. Foster Products Corporation, H. B. Fuller Company; 35-00.
 - c. ITW TACC, Division of Illinois Tool Works; CB-05/15.
 - d. Marathon Industries, Inc.; 550.
 - e. Mon-Eco Industries, Inc.; 55-50.
 - f. Vimasco Corporation; WC-1/WC-5.
 2. Water-Vapor Permeance: ASTM F 1249, 3 perms at 0.0625-inch dry film thickness.
 3. Service Temperature Range: Minus 20 to plus 200 deg F.
 4. Solids Content: 63 percent by volume and 73 percent by weight.
 5. Color: White.

2.06 PLUMBING PIPING SYSTEM INSULATION

- A. Insulation Omitted: Omit insulation on chrome-plated exposed piping (except for handicapped fixtures), air chambers, unions, strainers, check valves, balance cocks, flow regulators, buried piping, fire protection piping, and pre-insulated equipment. **Materials and thicknesses in schedules below are for single-layer applications. If multilayer applications are needed, insert additional requirements.**

2.07 EQUIPMENT INSULATION SCHEDULE

- A. Insulation materials and thicknesses are identified below. If more than one material is listed for a type of equipment, selection from materials listed is Contractor's option.
- B. Insulate indoor and outdoor equipment in paragraphs below that is not factory insulated.
1. Cellular Glass: 2 inches thick.
 2. Phenolic: 1 inch thick.
- C. Domestic cold water, and domestic hot-water hydro-pneumatic tank insulation shall be one of the following:
1. Cellular Glass: 1-1/2 inches thick.
 2. Flexible Elastomeric: 1 inch thick.
 3. Mineral-Fiber Pipe and Tank: 1 inch thick.
- D. Domestic hot-water storage tank insulation shall be one of the following, of thickness to provide an R-value of 12.5:
1. Cellular glass.
 2. Mineral-fiber pipe and tank.
 3. Phenolic.

2.08 PIPING INSULATION SCHEDULE, GENERAL

- A. Acceptable preformed pipe and tubular insulation materials and thicknesses are identified for each piping system and pipe size range. If more than one material is listed for a piping system, selection from materials listed is Contractor's option.
- B. Items Not Insulated: Unless otherwise indicated, do not install insulation on the following:
 - 1. Drainage piping located in crawl spaces.
 - 2. Underground piping.
 - 3. Chrome-plated pipes and fittings unless there is a potential for personnel injury.

2.09 INDOOR PIPING INSULATION SCHEDULE

- A. Domestic Cold Water:
 - 1. NPS 1 and Smaller: Insulation shall be one of the following:
 - a. Cellular Glass: 1-1/2 inches thick.
 - b. Flexible Elastomeric: 1 inch thick.
 - 2. NPS 1-1/4 and Larger: Insulation shall be one of the following:
 - a. Cellular Glass: 1-1/2 inches thick.
 - b. Flexible Elastomeric: 1 inch thick.
- B. Domestic Hot water and Re-circulated Hot Water:
 - 1. NPS 1-1/4 and Smaller: Insulation shall be one of the following:
 - a. Cellular Glass: 1-1/2 inches thick.
 - b. Flexible Elastomeric: 1 inch thick.
 - 2. NPS 1-1/2 and Larger: Insulation shall be one of the following:
 - a. Cellular Glass: 1-1/2 inches thick.
 - b. Flexible Elastomeric: 1 inch thick.
- C. Storm water and Overflow:
 - 1. All Pipe Sizes: Insulation shall be one of the following:
 - a. Cellular Glass: 1-1/2 inches thick.
 - b. Flexible Elastomeric: 1 inch thick.
- D. Roof Drain and Overflow Drain Bodies:
 - 1. All Pipe Sizes: Insulation shall be one of the following:
 - a. Cellular Glass: 1-1/2 inches thick.
 - b. Flexible Elastomeric: 1 inch thick.
- E. Exposed Sanitary Drains, Domestic Water, Domestic Hot Water, and Stops for Plumbing Fixtures for People with Disabilities:
 - 1. All Pipe Sizes: Insulation shall be one of the following:
 - a. Flexible Elastomeric: 3/4 inch thick.
 - b. Polyolefin: 3/4 inch thick.
- F. Condensate and Equipment Drain Water below 60 Deg F:
 - 1. All Pipe Sizes: Insulation shall be one of the following:
 - a. Cellular Glass: 1-1/2 inches thick.
 - b. Flexible Elastomeric: 1 inch thick.

- G. Floor Drains, Traps, and Sanitary Drain Piping within 10 Feet of Drain Receiving Condensate and Equipment Drain Water below 60 Deg F:
 - 1. All Pipe Sizes: Insulation shall be one of the following:
 - a. Cellular Glass: 1-1/2 inches thick.
 - b. Flexible Elastomeric: 1 inch thick.

2.10 INDOOR, FIELD-APPLIED JACKET SCHEDULE

- A. Install jacket over insulation material. For insulation with factory-applied jacket, install the field-applied jacket over the factory-applied jacket.
- B. If more than one material is listed, selection from materials listed is Contractor's option.
- C. Equipment, Exposed, up to 48 Inches in Diameter or with Flat Surfaces up to 72 Inches:
- D. Piping, Exposed:
 - 1. PVC, Color-Coded by System: 20 mils 30 mils thick.
 - 2. Aluminum, Smooth 0.024 inch thick.

2.11 OUTDOOR, FIELD-APPLIED JACKET SCHEDULE

- A. Install jacket over insulation material. For insulation with factory-applied jacket, install the field-applied jacket over the factory-applied jacket.
- B. If more than one material is listed, selection from materials listed is Contractor's option.
- C. Equipment, Exposed, up to 48 Inches in Diameter or with Flat Surfaces up to 72 Inches:
 - 1. Aluminum, Smooth with Z-Shaped Locking Seam: 0.024 inch thick.
- D. Piping, Exposed:
 - 1. Aluminum, Smooth with Z-Shaped Locking Seam: 0.024 inch thick.

2.12 UNDERGROUND, FIELD-INSTALLED INSULATION JACKET

- A. For underground direct-buried piping applications, install underground direct-buried jacket over insulation material.

END OF SECTION

SECTION 221116 - DOMESTIC WATER PIPING

PART 1 - GENERAL

1.01 RELATED DOCUMENTS

- A. Drawings and general provisions of the Contract, including General and Supplementary Conditions and Division 01 Specification Sections, apply to this Section.

1.02 SUMMARY

- A. Section Includes:
 - 1. Under-building slab and above ground domestic water pipes, tubes, fittings, and specialties inside the building.
 - 2. Encasement for piping.
 - 3. Specialty valves.
 - 4. Flexible connectors.
 - 5. Water meters.
 - 6. Escutcheons.
 - 7. Sleeves and sleeve seals.
 - 8. Wall penetration systems.

1.03 SUBMITTALS

- A. Product Data: For the following products:
 - 1. Specialty valves.
 - 2. Transition fittings.
 - 3. Dielectric fittings.
 - 4. Flexible connectors.
 - 5. Water meters.
 - 6. Backflow preventers and vacuum breakers.
 - 7. Escutcheons.
 - 8. Sleeves and sleeve seals.
 - 9. Water penetration systems.
- B. Water Samples: Specified in "Cleaning" Article.
- C. Coordination Drawings: For piping in equipment rooms and other congested areas, drawn to scale, on which the following items are shown and coordinated with each other, using input from Installers of the items involved:
 - 1. Fire-suppression-water piping.
 - 2. Domestic water piping.
 - 3. Compressed air piping.
 - 4. HVAC hydronic piping.
- D. Field quality-control reports.

1.04 QUALITY ASSURANCE

- A. Piping materials shall bear label, stamp, or other markings of specified testing agency.
- B. Comply with NSF 14 for plastic, potable domestic water piping and components. Include marking "NSF-pw" on piping.
- C. Comply with NSF 61 for potable domestic water piping and components.

1.05 PROJECT CONDITIONS

- A. Interruption of Existing Water Service: Do not interrupt water service to facilities occupied by Owner or others unless permitted under the following conditions and then only after arranging to provide temporary water service according to requirements indicated:
 - 1. Notify Architect and Construction Manager no fewer than two days in advance of proposed interruption of water service.
 - 2. Do not proceed with interruption of water service without Architect's and Construction Manager's written permission.

1.06 COORDINATION

- A. Coordinate sizes and locations of concrete bases with actual equipment provided.

PART 2 - PRODUCTS

2.01 PIPING MATERIALS

- A. Comply with requirements in "Piping Schedule" Article for applications of pipe, tube, fitting materials, and joining methods for specific services, service locations, and pipe sizes.

2.02 COPPER TUBE AND FITTINGS

- A. Hard Copper Tube: ASTM B 88, Type L water tube, drawn temper, copper pipe made of deoxidized copper (99.9% pure) shall be used for all domestic cold hot water and hot water return piping. No pipe smaller than three-fourths inches (3/4") shall be used in this project except at local connections.
 - 1. Cast-Copper Solder-Joint Fittings: ASME B16.18, pressure fittings.
 - 2. Wrought-Copper Solder-Joint Fittings: ASME B16.22, wrought-copper pressure fittings.
 - 3. Bronze Flanges: ASME B16.24, Class 150, with solder-joint ends.
 - 4. Copper Unions: MSS SP-123, cast-copper-alloy, hexagonal-stock body, with ball-and-socket, metal-to-metal seating surfaces, and solder-joint or threaded ends.

2.03 DUCTILE-IRON PIPE AND FITTINGS

- A. Mechanical-Joint, Ductile-Iron Pipe: AWWA C151, with mechanical-joint bell and plain spigot end unless grooved or flanged ends are indicated.
 - 1. Standard-Pattern, Mechanical-Joint Fittings: AWWA C110, ductile or gray iron.
 - 2. Compact-Pattern, Mechanical-Joint Fittings: AWWA C153, ductile iron.
 - a. Glands, Gaskets, and Bolts: AWWA C111, ductile- or gray-iron glands, rubber gaskets, and steel bolts.
- B. Push-on-Joint, Ductile-Iron Pipe: AWWA C151, with push-on-joint bell and plain spigot end unless grooved or flanged ends are indicated.
 - 1. Standard-Pattern, Push-on-Joint Fittings: AWWA C110, ductile or gray iron.
 - a. Gaskets: AWWA C111, rubber.
 - 2. Compact-Pattern, Push-on-Joint Fittings: AWWA C153, ductile iron.
 - a. Gaskets: AWWA C111, rubber.
- C. Plain-End, Ductile-Iron Pipe: AWWA C151.
 - 1. Grooved-Joint, Ductile-Iron-Pipe Appurtenances:
 - a. Manufacturers: Subject to compliance with requirements, provide products by one of the following:
 - (1) Anvil International.
 - (2) Shurjoint Piping Products.
 - (3) Star Pipe Products.
 - b. Grooved-End, Ductile-Iron Fittings: ASTM A 47/A 47M, malleable-iron castings or ASTM A 536, ductile-iron castings with dimensions matching pipe.
 - c. Grooved-End, Ductile-Iron-Pipe Couplings: AWWA C606 for ductile-iron-pipe dimensions. Include ferrous housing sections, EPDM-rubber gaskets suitable for hot and cold water, and bolts and nuts.

2.04 PIPING JOINING MATERIALS

- A. Pipe-Flange Gasket Materials: AWWA C110, rubber, flat face, 1/8 inch thick or ASME B16.21, nonmetallic and asbestos free, unless otherwise indicated; full-face or ring type unless otherwise indicated.
- B. Metal, Pipe-Flange Bolts and Nuts: ASME B18.2.1, carbon steel unless otherwise indicated.
- C. Solder Filler Metals: ASTM B 32, lead-free alloys. Include water-flushable flux according to ASTM B 813.
- D. Brazing Filler Metals: AWS A5.8/A5.8M, BCuP Series, copper-phosphorus alloys for general-duty brazing unless otherwise indicated.
- E. Solvent Cements for Joining CPVC Piping and Tubing: ASTM F 493.
 - 1. Use CPVC solvent cement that has a VOC content of 490 g/L or less when calculated according to 40 CFR 59, Subpart D (EPA Method 24).
 - 2. Use adhesive primer that has a VOC content of 550 g/L or less when calculated according to 40 CFR 59, Subpart D (EPA Method 24).
- F. Solvent Cements for Joining PVC Piping: ASTM D 2564. Include primer according to ASTM F 656.
 - 1. Use PVC solvent cement that has a VOC content of 510 g/L or less when calculated according to 40 CFR 59, Subpart D (EPA Method 24).
 - 2. Use adhesive primer that has a VOC content of 550 g/L or less when calculated according to 40 CFR 59, Subpart D (EPA Method 24).
- G. Plastic, Pipe-Flange Gaskets, Bolts, and Nuts: Type and material recommended by piping system manufacturer unless otherwise indicated.

2.05 REQUIREMENTS OF INTERIOR WATER PIPING SYSTEMS

- 1. All piping shall have reducing fittings used for reducing or increasing where any change in the pipe sizes occurs. No bushing of any nature shall be allowed in piping.
- 2. All exposed chrome plated, polished or enameled connections from fixtures shall be put up with special care, showing no tool marks or threads at fittings, and supported by neat racks or hangers with round head screws of same material and finish.
- 3. Wade Shokstop, or approved equal, sealed air chambers shall be provided in all water branches to fixtures, sized in accordance with manufacturer's recommendations, concealed, accessible, and located so as to protect each group of plumbing fixtures.
- 4. The fabrication of copper pipe and fittings shall in every detail conform to the recommendations and instructions of the fitting manufacturer. The tools used shall be the tools adapted to that specific purpose

2.06 SPECIALTY VALVES

- A. Comply with requirements in Division 22 Section "General-Duty Valves for Plumbing Piping" for general-duty metal valves.
- B. Comply with requirements in Division 22 Section "Domestic Water Piping Specialties" for balancing valves, drain valves, backflow preventers, and vacuum breakers.

2.07 TRANSITION FITTINGS

- A. General Requirements:
 - 1. Same size as pipes to be joined.
 - 2. Pressure rating at least equal to pipes to be joined.
 - 3. End connections compatible with pipes to be joined.
- B. Fitting-Type Transition Couplings: Manufactured piping coupling or specified piping system fitting.
- C. Sleeve-Type Transition Coupling: AWWA C219.
 - 1. Manufacturers: Subject to compliance with requirements, provide products by one of the following:
 - a. Cascade Waterworks Manufacturing.
 - b. Dresser, Inc.; Dresser Piping Specialties.
 - c. Ford Meter Box Company, Inc. (The).
 - d. JCM Industries.
 - e. Romac Industries, Inc.

- f. Smith-Blair, Inc; a Sensus company.
 - g. Viking Johnson; c/o Mueller Co.
- D. Plastic-to-Metal Transition Fittings:
1. Manufacturers: Subject to compliance with requirements, provide products by one of the following:
 - a. Charlotte Pipe and Foundry Company.
 - b. Harvel Plastics, Inc.
 - c. Spears Manufacturing Company.
 2. Description: CPVC or PVC one-piece fitting with manufacturer's Schedule 80 equivalent dimensions; one end with threaded brass insert and one solvent-cement-socket or threaded end.

2.08 DIELECTRIC FITTINGS

- A. General Requirements: Assembly of copper alloy and ferrous materials or ferrous material body with separating nonconductive insulating material suitable for system fluid, pressure, and temperature.
- B. Dielectric Unions:
1. Manufacturers: Subject to compliance with requirements, provide products by one of the following:
 - a. Capitol Manufacturing Company.
 - b. Central Plastics Company.
 - c. EPCO Sales, Inc.
 - d. Hart Industries International, Inc.
 - e. Watts Regulator Co.; a division of Watts Water Technologies, Inc.
 - f. Zurn Plumbing Products Group; Wilkins Water Control Products.
 2. Description:
 - a. Pressure Rating: 150 psig at 180 deg F.
 - b. End Connections: Solder-joint copper alloy and threaded ferrous.
- C. Dielectric Flanges:
1. Manufacturers: Subject to compliance with requirements, provide products by one of the following:
 - a. Capitol Manufacturing Company.
 - b. Central Plastics Company.
 - c. EPCO Sales, Inc.
 - d. Watts Regulator Co.; a division of Watts Water Technologies, Inc.
 2. Description:
 - a. Factory-fabricated, bolted, companion-flange assembly.
 - b. Pressure Rating: 150 psig.
 - c. End Connections: Solder-joint copper alloy and threaded ferrous; threaded solder-joint copper alloy and threaded ferrous.
- D. Dielectric-Flange Kits:
1. Manufacturers: Subject to compliance with requirements, provide products by one of the following:
 - a. Advance Products & Systems, Inc.
 - b. Calpico, Inc.
 - c. Central Plastics Company.
 - d. Pipeline Seal and Insulator, Inc.
 2. Description:
 - a. Non-conducting materials for field assembly of companion flanges.
 - b. Pressure Rating: 150 psig.
 - c. Gasket: Neoprene or phenolic.
 - d. Bolt Sleeves: Phenolic or polyethylene.
 - e. Washers: Phenolic with steel backing washers.
- E. Dielectric Couplings:
1. Manufacturers: Subject to compliance with requirements, provide products by one of the following:

- a. Calpico, Inc.
- b. Lochinvar Corporation.
- 2. Description:
 - a. Galvanized-steel coupling.
 - b. Pressure Rating: 300 psig at 225 deg F.
 - c. End Connections: Female threaded.
 - d. Lining: Inert and noncorrosive, thermoplastic.
- F. Dielectric Nipples:
 - 1. Manufacturers: Subject to compliance with requirements, provide products by one of the following:
 - a. Perfection Corporation; a subsidiary of American Meter Company.
 - b. Precision Plumbing Products, Inc.
 - 2. Description:
 - a. Electroplated steel nipple complying with ASTM F 1545.
 - b. Pressure Rating: 300 psig at 225 deg F.
 - c. End Connections: Male threaded or grooved.
 - d. Lining: Inert and noncorrosive, propylene.

2.09 FLEXIBLE CONNECTORS

- A. Manufacturers: Subject to compliance with requirements, provide products by one of the following:
 - 1. Flex-Hose Co., Inc.
 - 2. Flexicraft Industries.
 - 3. Flex Pression, Ltd.
 - 4. Flex-Weld, Inc.
 - 5. Metraflex, Inc.
- B. Bronze-Hose Flexible Connectors: Corrugated-bronze tubing with bronze wire-braid covering and ends brazed to inner tubing.
 - 1. Working-Pressure Rating: Minimum 200 psig.
 - 2. End Connections NPS 2 and Smaller: Threaded copper pipe or plain-end copper tube.
 - 3. End Connections NPS 2-1/2 and Larger: Flanged copper alloy.
- C. Stainless-Steel-Hose Flexible Connectors: Corrugated-stainless-steel tubing with stainless-steel wire-braid covering and ends welded to inner tubing.
 - 1. Working-Pressure Rating: Minimum 200 psig.
 - 2. End Connections NPS 2 and Smaller: Threaded steel-pipe nipple.
 - 3. End Connections NPS 2-1/2 and Larger: Flanged steel nipple.

2.10 ESCUTCHEONS

- A. General: Manufactured ceiling, floor, and wall escutcheons and floor plates.
- B. Split Casting, Cast Brass: Polished, chrome-plated or rough-brass finish with concealed hinge and setscrew.
- C. Split-Casting Floor Plates: Cast brass with concealed hinge.

2.11 SLEEVES

- A. Galvanized-Steel-Pipe Sleeves: ASTM A 53/A 53M, Type E, Grade B, Schedule 40, zinc-coated, with plain ends.
- B. Stack Sleeve Fittings: Manufactured, cast-iron sleeve with integral clamping flange. Include clamping ring and bolts and nuts for membrane flashing.
 - 1. Underdeck Clamp: Clamping ring with setscrews.

2.12 SLEEVE SEALS

- A. Manufacturers: Subject to compliance with requirements, provide products by one of the following:

1. Advance Products & Systems, Inc.
 2. Calpico, Inc.
 3. Metraflex, Inc.
 4. Pipeline Seal and Insulator, Inc.
- B. Description: Modular sealing element unit, designed for field assembly, used to fill annular space between pipe and sleeve.
1. Sealing Elements: EPDM-rubber interlocking links shaped to fit surface of pipe. Include type and number required for pipe material and size of pipe.
 2. Pressure Plates: Stainless steel.
 3. Connecting Bolts and Nuts: Stainless steel of length required to secure pressure plates to sealing elements.

2.13 VALVE BOXES

- A. For each underground valve installed by the Contractor, the Contractor shall provide and install a two-piece, screw adjustable type valve box. These valve boxes shall be designed for heavy roadway service and they shall have a deep socket type of cover which prevents their being accidentally knocked out of position.
- B. The word "WATER" shall appear on each cover. The installation of these members shall be such that by the use of the adjustable screw type bodies the tops are just flush with the finished grade. These valve boxes shall be Tyler Pipe Industries #6850, or approved equal.

2.14 WALL PENETRATION SYSTEMS

- A. Manufacturers: Subject to compliance with requirements, provide products by one of the following:
1. SIGMA.
- B. Description: Wall-sleeve assembly, consisting of housing and gland, gaskets, and pipe sleeve.
1. Carrier-Pipe Deflection: Up to 5 percent without leakage.
 2. Housing: Ductile-iron casting with hub, waterstop, anchor ring, and locking devices. Include gland, bolts, and nuts.
 3. Housing-to-Sleeve Gasket: EPDM rubber.
 4. Housing-to-Carrier-Pipe Gasket: AWWA C111, EPDM rubber.
 5. Pipe Sleeve: ASTM A 53/A 53M, Schedule 40, zinc-coated steel pipe.

PART 3 - EXECUTION

3.01 PIPING INSTALLATION

- A. Drawing plans, schematics, and diagrams indicate general location and arrangement of domestic water piping. Indicated locations and arrangements are used to size pipe and calculate friction loss, expansion, and other design considerations. Install piping as indicated unless deviations to layout are approved on Coordination Drawings.
- B. Backflow prevention valves shall be installed on all chilled and hot water make-up lines.
- C. Backflow prevention valves shall be installed on all irrigation systems per code.
- D. Double-check valves are not an acceptable alternate to backflow preventers.
- E. Install copper tubing under building slab according to CDA's "Copper Tube Handbook."
- F. Install ductile-iron piping under building slab with restrained joints according to AWWA C600 and AWWA M41.
- G. Install underground ductile-iron pipe in PE encasement according to ASTM A 674 or AWWA C105.
- H. Install shutoff valve, hose-end drain valve, strainer, pressure gage, and test tee with valve, inside the building at each domestic water service entrance. Comply with requirements in Division 22 Section "Meters and Gages for Plumbing Piping" for pressure gages and Division 22 Section "Domestic Water Piping Specialties" for drain valves and strainers.
- I. Install shutoff valve immediately upstream of each dielectric fitting.
- J. Install water-pressure-reducing valves downstream from shutoff valves. Comply with requirements in Division 22 Section "Domestic Water Piping Specialties" for pressure-reducing valves.

- K. Install domestic water piping level and plumb.
- L. Rough-in domestic water piping for water-meter installation according to utility company's requirements.
- M. Install piping concealed from view and protected from physical contact by building occupants unless otherwise indicated and except in equipment rooms and service areas.
- N. Install piping indicated to be exposed and piping in equipment rooms and service areas at right angles or parallel to building walls. Diagonal runs are prohibited unless specifically indicated otherwise.
- O. Install piping above accessible ceilings to allow sufficient space for ceiling panel removal, and coordinate with other services occupying that space.
- P. Install piping adjacent to equipment and specialties to allow service and maintenance.
- Q. Install piping to permit valve servicing.
- R. Install nipples, unions, special fittings, and valves with pressure ratings the same as or higher than system pressure rating used in applications below unless otherwise indicated.
- S. Install piping free of sags and bends.
- T. Install fittings for changes in direction and branch connections.
- U. Install PEX piping with loop at each change of direction of more than 90 degrees.
- V. Install unions in copper tubing at final connection to each piece of equipment, machine, and specialty.
- W. Install pressure gages on suction and discharge piping from each plumbing pump and packaged booster pump. Comply with requirements in Division 22 Section "Meters and Gages for Plumbing Piping" for pressure gages.
- X. Install thermostats in hot-water circulation piping. Comply with requirements in Division 22 Section "Domestic Water Pumps" for thermostats.
- Y. Install thermometers on inlet and outlet piping from each water heater. Comply with requirements in Division 22 Section "Meters and Gages for Plumbing Piping" for thermometers.
- Z. Cast iron, glass, and galvanized pipes are not acceptable.

3.02 JOINT CONSTRUCTION

- A. Ream ends of pipes and tubes and remove burrs. Bevel plain ends of steel pipe.
- B. Remove scale, slag, dirt, and debris from inside and outside of pipes, tubes, and fittings before assembly.
- C. Threaded Joints: Thread pipe with tapered pipe threads according to ASME B1.20.1. Cut threads full and clean using sharp dies. Ream threaded pipe ends to remove burrs and restore full ID. Join pipe fittings and valves as follows:
 - 1. Apply appropriate tape or thread compound to external pipe threads.
 - 2. Damaged Threads: Do not use pipe or pipe fittings with threads that are corroded or damaged.
- D. Brazed Joints: Join copper tube and fittings according to CDA's "Copper Tube Handbook," "Brazed Joints" Chapter.
- E. Soldered Joints: Apply ASTM B 813, water-flushable flux to end of tube. Join copper tube and fittings according to ASTM B 828 or CDA's "Copper Tube Handbook."
- F. Copper-Tubing, Push-on Joints: Clean end of tube. Measure insertion depth with manufacturer's depth gage. Join copper tube and push-on-joint fittings by inserting tube to measured depth.
- G. Copper-Tubing Grooved Joints: Roll groove end of tube. Assemble coupling with housing, gasket, lubricant, and bolts. Join copper tube and grooved-end fittings according to AWWA C606 for roll-grooved joints.
- H. Ductile-Iron-Piping Grooved Joints: Cut groove end of pipe. Assemble coupling with housing, gasket, lubricant, and bolts. Join ductile-iron pipe and grooved-end fittings according to AWWA C606 for ductile-iron-pipe, cut-grooved joints.
- I. Steel-Piping Grooved Joints: Cut or roll groove end of pipe. Assemble coupling with housing, gasket, lubricant, and bolts. Join steel pipe and grooved-end fittings according to AWWA C606 for steel-pipe grooved joints.
- J. Flanged Joints: Select appropriate asbestos-free, nonmetallic gasket material in size, type, and thickness suitable for domestic water service. Join flanges with gasket and bolts according to ASME B31.9.

- K. Dissimilar-Material Piping Joints: Make joints using adapters compatible with materials of both piping systems.

3.03 VALVE INSTALLATION

- A. General-Duty Valves: Comply with requirements in Division 22 Section "General-Duty Valves for Plumbing Piping" for valve installations.
- B. Shut off valves shall be installed on all branch lines. All toilet rooms, any room with multiple fixtures (i.e. science labs), coffee bars, drinking fountains, and any exterior hose bib shall have their own isolation valves.
- C. All valves shall be accessible to Owner.
- D. Install shutoff valve close to water main on each branch and riser serving plumbing fixtures or equipment, on each water supply to equipment, and on each water supply to plumbing fixtures that do not have supply stops. Use ball or gate valves for piping NPS 2 and smaller. Use butterfly or gate valves for piping NPS 2-1/2 and larger.
- E. Install drain valves for equipment at base of each water riser, at low points in horizontal piping, and where required to drain water piping. Drain valves are specified in Division 22 Section "Domestic Water Piping Specialties."
 - 1. Hose-End Drain Valves: At low points in water mains, risers, and branches.
 - 2. Stop-and-Waste Drain Valves: Instead of hose-end drain valves where indicated.
- F. Install balancing valve in each hot-water circulation return branch and discharge side of each pump and circulator. Set balancing valves partly open to restrict but not stop flow. Use ball valves for piping NPS 2 and smaller and butterfly valves for piping NPS 2-1/2 and larger. Comply with requirements in Division 22 Section "Domestic Water Piping Specialties" for balancing valves.
- G. Install calibrated balancing valves in each hot-water circulation return branch and discharge side of each pump and circulator. Set calibrated balancing valves partly open to restrict but not stop flow. Comply with requirements in Division 22 Section "Domestic Water Piping Specialties" for calibrated balancing valves.

3.04 FLEXIBLE CONNECTOR INSTALLATION

- A. Install flexible connectors in suction and discharge piping connections to each domestic water pump.
- B. Install bronze-hose flexible connectors in copper domestic water tubing.
- C. Install stainless-steel-hose flexible connectors in steel domestic water piping.

3.05 WATER METER INSTALLATION

- A. Rough-in domestic water piping according to utility company's requirements.
- B. Water meters will be furnished and installed by utility company.
- C. Install water meters according to AWWA M6, utility company's requirements, and the following:
- D. Install displacement-type water meters with shutoff valve on water-meter inlet. Install valve on water-meter outlet and valved bypass around meter unless prohibited by authorities having jurisdiction.
- E. Install turbine-type water meters with shutoff valve on water-meter inlet. Install valve on water-meter outlet and valved bypass around meter unless prohibited by authorities having jurisdiction.
- F. Install compound-type water meters with shutoff valves on water-meter inlet and outlet and on valved bypass around meter. Support meters, valves, and piping on brick or concrete piers.
- G. Install fire-service water meters with shutoff valves on water-meter inlet and outlet and on full-size valved bypass around meter. Support meter, valves, and piping on brick or concrete piers.
- H. Install remote registration system according to standards of utility company and of authorities having jurisdiction.

H ANGER AND SUPPORT INSTALLATION

- I. Comply with requirements in Division 22 Section "Vibration and Seismic Controls for Plumbing Piping and Equipment" for seismic-restraint devices.
- J. Comply with requirements in Division 22 Section "Hangers and Supports for Plumbing Piping and Equipment" for pipe hanger and support products and installation.

1. Vertical Piping: MSS Type 8 or 42, clamps.
 2. Individual, Straight, Horizontal Piping Runs:
 - a. 100 Feet and Less: MSS Type 1, adjustable, steel clevis hangers.
 - b. Longer Than 100 Feet: MSS Type 43, adjustable roller hangers.
 - c. Longer Than 100 Feet If Indicated: MSS Type 49, spring cushion rolls.
 3. Multiple, Straight, Horizontal Piping Runs 100 Feet or Longer: MSS Type 44, pipe rolls. Support pipe rolls on trapeze.
 4. Base of Vertical Piping: MSS Type 52, spring hangers.
- K. Support vertical piping and tubing at base and at each floor.
- L. Rod diameter may be reduced one size for double-rod hangers, to a minimum of 3/8 inch.
- M. Install hangers for copper tubing with the following maximum horizontal spacing and minimum rod diameters:
1. NPS 3/4 and Smaller: 60 inches with 3/8-inch rod.
 2. NPS 1 and NPS 1-1/4: 72 inches with 3/8-inch rod.
 3. NPS 1-1/2 and NPS 2: 96 inches with 3/8-inch rod.
 4. NPS 2-1/2: 108 inches with 1/2-inch rod.
 5. NPS 3 to NPS 5: 10 feet with 1/2-inch rod.
 6. NPS 6: 10 feet with 5/8-inch rod.
- N. Install supports for vertical copper tubing every 10 feet.

3.06 CONNECTIONS

- A. Drawings indicate general arrangement of piping, fittings, and specialties.
- B. Install piping adjacent to equipment and machines to allow service and maintenance.
- C. Connect domestic water piping to exterior water-service piping. Use transition fitting to join dissimilar piping materials.
- D. Connect domestic water piping to water-service piping with shutoff valve; extend and connect to the following:
 1. Water Heaters: Cold-water inlet and hot-water outlet piping in sizes indicated, but not smaller than sizes of water heater connections.
 2. Plumbing Fixtures: Cold- and hot-water supply piping in sizes indicated, but not smaller than required by plumbing code. Comply with requirements in Division 22 plumbing fixture Sections for connection sizes.
 3. Equipment: Cold- and hot-water supply piping as indicated, but not smaller than equipment connections. Provide shutoff valve and union for each connection. Use flanges instead of unions for NPS 2-1/2 and larger.

3.07 IDENTIFICATION

- A. Identify system components. Comply with requirements in Division 22 Section "Identification for Plumbing Piping and Equipment" for identification materials and installation.
- B. Label pressure piping with system operating pressure.

3.08 FIELD QUALITY CONTROL

- A. Perform tests and inspections.
- B. Piping Inspections:
 1. Do not enclose, cover, or put piping into operation until it has been inspected and approved by authorities having jurisdiction.
 2. During installation, notify authorities having jurisdiction at least one day before inspection must be made. Perform tests specified below in presence of authorities having jurisdiction:
 - a. Roughing-in Inspection: Arrange for inspection of piping before concealing or closing-in after roughing-in and before setting fixtures.
 - b. Final Inspection: Arrange final inspection for authorities having jurisdiction to observe tests specified below and to ensure compliance with requirements.
 3. Re-inspection: If authorities having jurisdiction find that piping will not pass tests or inspections, make required corrections and arrange for re-inspection.
 4. Reports: Prepare inspection reports and have them signed by authorities having jurisdiction.

- C. Piping Tests:
1. Fill domestic water piping. Check components to determine that they are not air bound and that piping is full of water.
 2. Test for leaks and defects in new piping and parts of existing piping that have been altered, extended, or repaired. If testing is performed in segments, submit a separate report for each test, complete with diagram of portion of piping tested.
 3. Leave new, altered, extended, or replaced domestic water piping uncovered and unconcealed until it has been tested and approved. Expose work that was covered or concealed before it was tested.
 4. Cap and subject piping to static water pressure of 50 psig above operating pressure, without exceeding pressure rating of piping system materials. Isolate test source and allow to stand for four (4) hours. Leaks and loss in test pressure constitute defects that must be repaired.
 5. Repair leaks and defects with new materials and retest piping or portion thereof until satisfactory results are obtained.
 6. Prepare reports for tests and for corrective action required.
- D. Domestic water piping will be considered defective if it does not pass tests and inspections.
- E. Prepare test and inspection reports.

3.09 ADJUSTING

- A. Perform the following adjustments before operation:
1. Close drain valves, hydrants, and hose bibbs.
 2. Open shutoff valves to fully open position.
 3. Open throttling valves to proper setting.
 4. Adjust balancing valves in hot-water-circulation return piping to provide adequate flow.
 - a. Manually adjust ball-type balancing valves in hot-water-circulation return piping to provide flow of hot water in each branch.
 - b. Adjust calibrated balancing valves to flows indicated.
 5. Remove plugs used during testing of piping and for temporary sealing of piping during installation.
 6. Remove and clean strainer screens. Close drain valves and replace drain plugs.
 7. Remove filter cartridges from housings and verify that cartridges are as specified for application where used and are clean and ready for use.
 8. Check plumbing specialties and verify proper settings, adjustments, and operation.

3.10 CLEANING

- A. Clean and disinfect potable domestic water piping as follows:
1. Purge new piping and parts of existing piping that have been altered, extended, or repaired before using.
 2. Use purging and disinfecting procedures prescribed by authorities having jurisdiction; if methods are not prescribed, use procedures described in either AWWA C651 or AWWA C652 or follow procedures described below:
 - a. Flush piping system with clean, potable water until dirty water does not appear at outlets.
 - b. Fill and isolate system according to either of the following:
 - (1) Fill system or part thereof with water/chlorine solution with at least 50 ppm of chlorine. Isolate with valves and allow to stand for 24 hours.
 - (2) Fill system or part thereof with water/chlorine solution with at least 200 ppm of chlorine. Isolate and allow to stand for three hours.
 - c. Flush system with clean, potable water until no chlorine is in water coming from system after the standing time.
 - d. Submit water samples in sterile bottles to authorities having jurisdiction. Repeat procedures if biological examination shows contamination.
- B. Clean non-potable domestic water piping as follows:
1. Purge new piping and parts of existing piping that have been altered, extended, or repaired before using.

2. Use purging procedures prescribed by authorities having jurisdiction or; if methods are not prescribed, follow procedures described below:
 - a. Flush piping system with clean, potable water until dirty water does not appear at outlets.
 - b. Submit water samples in sterile bottles to authorities having jurisdiction. Repeat procedures if biological examination shows contamination.
- C. Prepare and submit reports of purging and disinfecting activities.
- D. Clean interior of domestic water piping system. Remove dirt and debris as work progresses.
- E. After completion of the testing, the entire cold and hot water piping systems, with attached equipment, shall be thoroughly sterilized with a solution containing not less than 50 parts per million of available chlorine. The chlorinating materials shall be either liquid chlorine conforming to U. S. Army Specification No. 4-1 or calcium hypochlorite or chlorinated lime conforming to the requirements of Federal Specification O-C-114. The sterilizing solution shall be allowed to remain in the system for a period of eight (8) hours during which time all valves and faucets shall be opened and closed several times. After sterilization, the solution shall be flushed from the system with clean water until the residual chlorine content is not greater than 0.2 parts per million.
- F. The sterilization process shall be conducted as required by the Health Department of the City of Houston, and the specifications above, and upon completion of the process, the Health Department shall test and certify the cleanliness of the water piping system. The Mechanical Subcontractor shall pay all costs and charges incidental to this test and certification.

3.11 VALVE SCHEDULE

- A. Drawings indicate valve types to be used. Where specific valve types are not indicated, the following requirements apply:
 1. Shutoff Duty: All interior plumbing valves 2" or less shall be ball valves. All valves greater than 2" shall be flanged ball valves.
 2. Throttling Duty: Use ball or globe valves for piping NPS 2 and smaller. Use butterfly or ball valves with flanged ends for piping NPS 2-1/2 and larger.
 3. Hot-Water Circulation Piping, Balancing Duty: Memory-stop balancing valves.
 4. Drain Duty: Hose-end drain valves.
- B. Use check valves to maintain correct direction of domestic water flow to and from equipment.
- C. Iron grooved-end valves may be used with grooved-end piping.
- D. Isolation valves shall be provided to isolate buildings, loops, and equipment.

END OF SECTION

SECTION 221119 - DOMESTIC WATER PIPING SPECIALTIES

PART 1 – GENERAL

1.01 RELATED DOCUMENTS

- A. Drawings and general provisions of the Contract, including General and Supplementary Conditions and Division 01 Specification Sections, apply to this Section.

1.02 SUMMARY

- A. This Section includes the following domestic water piping specialties:
 - 1. Vacuum breakers.
 - 2. Backflow preventers.
 - 3. Water pressure-reducing valves.
 - 4. Balancing valves.
 - 5. Temperature-actuated water mixing valves.
 - 6. Strainers.
 - 7. Outlet boxes.
 - 8. Hose stations.
 - 9. Hose bibbs.
 - 10. Wall hydrants.
 - 11. Drain valves.
 - 12. Water hammer arresters.
 - 13. Air vents.
 - 14. Trap-seal primer valves.
 - 15. Trap-seal primer systems.
- B. Related Sections include the following:
 - 1. Division 22 Section "Domestic Water Piping" for water meters.

1.03 PERFORMANCE REQUIREMENTS

- A. Coordinate this Article with Division 22 Section "Domestic Water Piping."
- B. Minimum Working Pressure for Domestic Water Piping Specialties: 125 psig, unless otherwise indicated.

1.04 SUBMITTALS

- A. Product Data: For each type of product indicated.
- B. Retain paragraph below if retaining Part 2 "Trap-Seal Primer Systems" Article.
- C. Shop Drawings: Diagram power, signal, and control wiring.
- D. Retain first paragraph below if Contractor is responsible for field quality-control testing.
- E. Field quality-control test reports.
- F. Operation and Maintenance Data: For domestic water piping specialties to include in emergency, operation, and maintenance manuals.

1.05 QUALITY ASSURANCE

- A. Electrical Components, Devices, and Accessories: Listed and labeled as defined in NFPA 70, Article 100, by a testing agency acceptable to authorities having jurisdiction, and marked for intended use.

PART 2 - PRODUCTS

2.01 VACUUM BREAKERS

- A. Pipe-Applied, Atmospheric-Type Vacuum Breakers:
 - 1. Available Manufacturers: Subject to compliance with requirements, manufacturers offering products that may be incorporated into the Work include, but are not limited to, the following:
 - 2. Manufacturers: Subject to compliance with requirements, provide products by one of the following:
 - a. Ames Co.
 - b. Cash Acme.
 - c. Conbraco Industries, Inc.
 - d. FEBCO; SPX Valves & Controls.
 - e. Rain Bird Corporation.
 - f. Toro Company (The); Irrigation Div.
 - g. Watts Industries, Inc.; Water Products Div.
 - h. Zurn Plumbing Products Group; Wilkins Div.
 - 3. Standard: ASSE 1001.
 - 4. Size: NPS 1/4 to NPS 3, as required to match connected piping.
 - 5. Body: Bronze.
 - 6. Inlet and Outlet Connections: Threaded.
 - 7. Finish: Rough bronze.
- B. Hose-Connection Vacuum Breakers:
 - 1. Available Manufacturers: Subject to compliance with requirements, manufacturers offering products that may be incorporated into the Work include, but are not limited to, the following:
 - 2. Manufacturers: Subject to compliance with requirements, provide products by one of the following:
 - a. Arrowhead Brass Products, Inc.
 - b. Cash Acme.
 - c. Conbraco Industries, Inc.
 - d. Legend Valve.
 - e. MIFAB, Inc.
 - f. Prier Products, Inc.
 - g. Watts Industries, Inc.; Water Products Div.
 - h. Woodford Manufacturing Company.
 - i. Zurn Plumbing Products Group; Light Commercial Operation.
 - j. Zurn Plumbing Products Group; Wilkins Div.
 - 3. Standard: ASSE 1011.
 - 4. Body: Bronze, nonremovable, with manual drain.

5. Outlet Connection: Garden-hose threaded complying with ASME B1.20.7.
 6. Finish: Chrome or nickel plated.
- C. Laboratory-Faucet Vacuum Breakers:
1. Available Manufacturers: Subject to compliance with requirements, manufacturers offering products that may be incorporated into the Work include, but are not limited to, the following:
 2. Manufacturers: Subject to compliance with requirements, provide products by one of the following:
 - a. Conbraco Industries, Inc.
 - b. Watts Industries, Inc.; Water Products Div.
 - c. Woodford Manufacturing Company.
 - d. Zurn Plumbing Products Group; Wilkins Div.
 - e. <Insert manufacturer's name.>
 3. Standard: ASSE 1035.
 4. Size: NPS 1/4 or NPS 3/8 matching faucet size.
 5. Body: Bronze.
 6. End Connections: Threaded.
 7. Finish: Chrome plated.

2.02 BACKFLOW PREVENTERS

- A. The contractor is responsible for certifying all newly installed backflow preventers and providing proof of certification to the Owner.
- B. Reduced-Pressure-Principle Backflow Preventers:
 1. Available Manufacturers: Subject to compliance with requirements, manufacturers offering products that may be incorporated into the Work include, but are not limited to, the following:
 2. Manufacturers: Subject to compliance with requirements, provide products by one of the following:
 3. Basis-of-Design Product: Subject to compliance with requirements, provide a comparable product by one of the following:
 - a. Ames Co.
 - b. Conbraco Industries, Inc.
 - c. FEBCO; SPX Valves & Controls.
 - d. Flomatic Corporation.
 - e. Watts Industries, Inc.; Water Products Div.
 - f. Zurn Plumbing Products Group; Wilkins Div.
 4. Standard: ASSE 1013.
 5. Operation: Continuous-pressure applications.
 6. Pressure Loss: 5 psi maximum, through middle 1/3 of flow range.
 7. Size: As indicated on drawings.
 8. Body: Bronze for NPS 2 and smaller; cast iron with interior lining complying with AWWA C550 or that is FDA approved for NPS 2-1/2 and larger.
 9. End Connections: Threaded for NPS 2 and smaller; flanged for NPS 2-1/2 and larger.
 10. Configuration: Designed for horizontal, straight through flow.
 11. Accessories:

- a. Valves: Ball type with threaded ends on inlet and outlet of NPS 2 and smaller; outside screw and yoke gate-type with flanged ends on inlet and outlet of NPS 2-1/2 and larger.
 - b. Air-Gap Fitting: ASME A112.1.2, matching backflow-preventer connection.
- C. Reduced-Pressure-Detector, Fire-Protection Backflow-Preventer Assemblies:
- 1. Available Manufacturers: Subject to compliance with requirements, manufacturers offering products that may be incorporated into the Work include, but are not limited to, the following:
 - 2. Manufacturers: Subject to compliance with requirements, provide products by one of the following:
 - 3. Basis-of-Design Product: Subject to compliance with requirements, provide or a comparable product by one of the following:
 - a. Ames Co.
 - b. Conbraco Industries, Inc.
 - c. FEBCO; SPX Valves & Controls.
 - d. Watts Industries, Inc.; Water Products Div.
 - e. Zurn Plumbing Products Group; Wilkins Div.
 - 4. Standard: ASSE 1047 and FMG approved or UL listed.
 - 5. Operation: Continuous-pressure applications.
 - 6. Pressure Loss: 7 psig maximum, through middle 1/3 of flow range.
 - 7. Size: As indicated on plans.
 - 8. Body: Cast iron with interior lining complying with AWWA C550 or that is FDA approved.
 - 9. End Connections: Flanged.
 - 10. Configuration: Designed for horizontal, straight through flow.
 - 11. Accessories:
 - a. Valves: Outside screw and yoke gate-type with flanged ends on inlet and outlet.
 - b. Air-Gap Fitting: ASME A112.1.2, matching backflow-preventer connection.
 - c. Bypass: With displacement-type water meter, shutoff valves, and reduced-pressure backflow preventer.

2.03 WATER PRESSURE-REDUCING VALVES

- A. Water Regulators:
- 1. Available Manufacturers: Subject to compliance with requirements, manufacturers offering products that may be incorporated into the Work include, but are not limited to, the following:
 - 2. Manufacturers: Subject to compliance with requirements, provide products by one of the following:
 - a. Cash Acme.
 - b. Conbraco Industries, Inc.
 - c. Honeywell Water Controls.
 - d. Watts Industries, Inc.; Water Products Div.
 - e. Zurn Plumbing Products Group; Wilkins Div.
 - 3. Standard: ASSE 1003.
 - 4. Pressure Rating: Initial working pressure of 150 psig.

5. Body: Bronze with chrome-plated finish for NPS 2 and smaller; cast iron with interior lining complying with AWWA C550 or that is FDA approved for NPS 2-1/2 and NPS 3.
6. Valves for Booster Heater Water Supply: Include integral bypass.
7. End Connections: Threaded for NPS 2 and smaller; flanged for NPS 2-1/2 and NPS 3.

2.04 BALANCING VALVES

- A. Copper-Alloy Calibrated Balancing Valves:
 1. Available Manufacturers: Subject to compliance with requirements, manufacturers offering products that may be incorporated into the Work include, but are not limited to, the following:
 2. Manufacturers: Subject to compliance with requirements, provide products by one of the following:
 3. Basis-of-Design Product: Subject to compliance with requirements, provide or a comparable product by one of the following:
 - a. Armstrong International, Inc.
 - b. Flo Fab Inc.
 - c. ITT Industries; Bell & Gossett Div.
 - d. NIBCO INC.
 - e. TAC Americas.
 - f. Taco, Inc.
 - g. Watts Industries, Inc.; Water Products Div.
 4. Type: Ball or Y-pattern globe valve with two readout ports and memory setting indicator.
 5. Body: bronze,
 6. Size: Same as connected piping, but not larger than NPS 2.
 7. Accessories: Meter hoses, fittings, valves, differential pressure meter, and carrying case.

2.05 TEMPERATURE-ACTUATED WATER MIXING VALVES

- A. Water-Temperature Limiting Devices:
 1. Available Manufacturers: Subject to compliance with requirements, manufacturers offering products that may be incorporated into the Work include, but are not limited to, the following:
 2. Manufacturers: Subject to compliance with requirements, provide products by one of the following:
 3. Basis-of-Design Product: Subject to compliance with requirements, provide or a comparable product by one of the following:
 - a. Armstrong International, Inc.
 - b. Cash Acme.
 - c. Conbraco Industries, Inc.
 - d. Honeywell Water Controls.
 - e. Legend Valve.
 - f. Leonard Valve Company.
 - g. Powers; a Watts Industries Co.
 - h. Symmons Industries, Inc.
 - i. Taco, Inc.
 - j. Watts Industries, Inc.; Water Products Div.
 - k. Zurn Plumbing Products Group; Wilkins Div.

4. Standard: ASSE 1017.
5. Pressure Rating: 125 psig.
6. Type: Thermostatically controlled water mixing valve.
7. Material: Bronze body with corrosion-resistant interior components.
8. Connections: Threaded inlets and outlet.
9. Accessories: Check stops on hot- and cold-water supplies, and adjustable, temperature-control handle.

2.06 STRAINERS FOR DOMESTIC WATER PIPING

A. Y-Pattern Strainers:

1. Pressure Rating: 125 psig minimum, unless otherwise indicated.
2. Body: Bronze for NPS 2 and smaller; cast iron with interior lining complying with AWWA C550 or FDA-approved, epoxy coating and for NPS 2-1/2 and larger.
3. End Connections: Threaded for NPS 2 and smaller; flanged for NPS 2-1/2 and larger.
4. Screen: Stainless steel with round perforations, unless otherwise indicated.
5. Perforation Size:
 - a. Strainers NPS 2 and Smaller: 0.020 inch.
 - b. Strainers NPS 2-1/2 to NPS 4: 0.045 inch.
 - c. Strainers NPS 5 and Larger: 0.10 inch.
6. Drain: Factory-installed, hose-end drain valve.

B. Icemaker Outlet Boxes:

1. Available Manufacturers: Subject to compliance with requirements, manufacturers offering products that may be incorporated into the Work include, but are not limited to, the following:
2. Manufacturers: Subject to compliance with requirements, provide products by one of the following:
 - a. Acorn Engineering Company.
 - b. IPS Corporation.
 - c. LSP Products Group, Inc.
 - d. Oatey.
 - e. Plastic Oddities; a division of Diverse Corporate Technologies.
3. Mounting: Recessed.
4. Material and Finish: Enameled-steel or epoxy-painted-steel box and faceplate.
5. Faucet: Valved fitting complying with ASME A112.18.1. Include NPS 1/2 or smaller copper tube outlet.
6. Supply Shutoff Fitting: NPS 1/2 gate, globe, or ball valve and NPS 1/2 copper, water tubing.

2.07 HOSE BIBBS

- A. Hose bibs shall be provided near every entrance into the building. They shall also be provided in custodial closets, restrooms (if custodial closet is not adjacent to restrooms), and mechanical rooms.
- B. Hose Bibbs:
 1. Standard: ASME A112.18.1 for sediment faucets.
 2. Body Material: Bronze.

3. Seat: Bronze, replaceable.
4. Supply Connections: NPS 1/2 or NPS 3/4 threaded or solder-joint inlet.
5. Outlet Connection: Garden-hose thread complying with ASME B1.20.7.
6. Pressure Rating: 125 psig.
7. Vacuum Breaker: Integral non-removable, drainable, hose-connection vacuum breaker complying with ASSE 1011.
8. Finish for Equipment Rooms: Rough bronze, or chrome or nickel plated.
9. Finish for Service Areas: Chrome or nickel plated.
10. Finish for Finished Rooms: Chrome or nickel plated.
11. Operation for Equipment Rooms: Wheel handle or operating key.
12. Operation for Service Areas: Operating key.
13. Include operating key with each operating-key hose bibb.
14. Include wall flange with each chrome- or nickel-plated hose bibb.

2.08 WALL HYDRANTS

A. Non-freeze Wall Hydrants:

1. Available Manufacturers: Subject to compliance with requirements, manufacturers offering products that may be incorporated into the Work include, but are not limited to, the following:
2. Manufacturers: Subject to compliance with requirements, provide products by one of the following:
 - a. Josam Company.
 - b. MIFAB, Inc.
 - c. Prier Products, Inc.
 - d. Smith, Jay R. Mfg. Co.; Division of Smith Industries, Inc.
 - e. Tyler Pipe; Wade Div.
 - f. Watts Drainage Products Inc.
 - g. Woodford Manufacturing Company.
 - h. Zurn Plumbing Products Group; Light Commercial Operation.
 - i. Zurn Plumbing Products Group; Specification Drainage Operation.
3. Standard: ASME A112.21.3M for concealed outlet, self-draining wall hydrants.
4. Pressure Rating: 125 psig.
5. Operation: Loose key.
6. Casing and Operating Rod: Of length required to match wall thickness. Include wall clamp.
7. Inlet: NPS 3/4 or NPS 1.
8. Outlet: Concealed, with integral vacuum breaker and garden-hose thread complying with ASME B1.20.7.
9. Box: Deep, flush mounting with cover.
10. Box and Cover Finish: Polished nickel bronze.
11. Outlet: Exposed, with integral vacuum breaker and garden-hose thread complying with ASME B1.20.7.
12. Nozzle and Wall-Plate Finish: Polished nickel bronze.
13. Operating Keys(s): One with each wall hydrant.

2.09 DRAIN VALVES

- A. Ball-Valve-Type, Hose-End Drain Valves:
 - 1. Standard: MSS SP-110 for standard-port, two-piece ball valves.
 - 2. Pressure Rating: 400-psig minimum CWP.
 - 3. Size: NPS 3/4.
 - 4. Body: Copper alloy.
 - 5. Ball: Chrome-plated brass.
 - 6. Seats and Seals: Replaceable.
 - 7. Handle: Vinyl-covered steel.
 - 8. Inlet: Threaded or solder joint.
 - 9. Outlet: Threaded, short nipple with garden-hose thread complying with ASME B1.20.7 and cap with brass chain.
- B. Gate-Valve-Type, Hose-End Drain Valves:
 - 1. Standard: MSS SP-80 for gate valves.
 - 2. Pressure Rating: Class 125.
 - 3. Size: NPS 3/4.
 - 4. Body: ASTM B 62 bronze.
 - 5. Inlet: NPS 3/4 threaded or solder joint.
 - 6. Outlet: Garden-hose thread complying with ASME B1.20.7 and cap with brass chain.

2.10 WATER HAMMER ARRESTERS

- A. Water Hammer Arresters:
 - 1. Available Manufacturers: Subject to compliance with requirements, manufacturers offering products that may be incorporated into the Work include, but are not limited to, the following:
 - 2. Manufacturers: Subject to compliance with requirements, provide products by one of the following:
 - a. AMTROL, Inc.
 - b. Josam Company.
 - c. MIFAB, Inc.
 - d. PPP Inc.
 - e. Sioux Chief Manufacturing Company, Inc.
 - f. Smith, Jay R. Mfg. Co.; Division of Smith Industries, Inc.
 - g. Tyler Pipe; Wade Div.
 - h. Watts Drainage Products Inc.
 - i. Zurn Plumbing Products Group; Specification Drainage Operation.
 - 3. Standard: ASSE 1010 or PDI-WH 201.
 - 4. Type: Metal bellows.
 - 5. Size: ASSE 1010, Sizes AA and A through F or PDI-WH 201, Sizes A through F.

2.11 AIR VENTS

- A. Bolted-Construction Automatic Air Vents:
 - 1. Body: Bronze.
 - 2. Pressure Rating: 125-psig minimum pressure rating at 140 deg F.
 - 3. Float: Replaceable, corrosion-resistant metal.

4. Mechanism and Seat: Stainless steel.
 5. Size: NPS 3/8 minimum inlet.
 6. Inlet and Vent Outlet End Connections: Threaded.
- B. Welded-Construction Automatic Air Vents:
1. Body: Stainless steel.
 2. Pressure Rating: 150-psig minimum pressure rating.
 3. Float: Replaceable, corrosion-resistant metal.
 4. Mechanism and Seat: Stainless steel.
 5. Size: NPS 3/8 minimum inlet.
 6. Inlet and Vent Outlet End Connections: Threaded.

2.12 TRAP-SEAL PRIMER VALVES

- A. Supply-Type, Trap-Seal Primer Valves:
1. Manufacturers: Subject to compliance with requirements, provide products by one of the following:
 - a. MIFAB, Inc.
 - b. PPP Inc.
 - c. Sioux Chief Manufacturing Company, Inc.
 - d. Smith, Jay R. Mfg. Co.; Division of Smith Industries, Inc.
 - e. Watts Industries, Inc.; Water Products Div.
 2. Standard: ASSE 1018.
 3. Pressure Rating: 125 psig minimum.
 4. Body: Bronze.
 5. Inlet and Outlet Connections: NPS 1/2 threaded, union, or solder joint.
 6. Gravity Drain Outlet Connection: NPS 1/2 threaded or solder joint.
 7. Finish: Chrome plated, or rough bronze for units used with pipe or tube that is not chrome finished.

Part 3 - Copy and edit paragraph and subparagraphs below for each type of drainage-type, trap-seal primer valve required. If only one type is required, drawing designation may be omitted.

PART 3 - EXECUTION

3.01 INSTALLATION

- A. Refer to Division 22 Section "Common Work Results for Plumbing" for piping joining materials, joint construction, and basic installation requirements.
- B. Install backflow preventers in each water supply to mechanical equipment and systems and to other equipment and water systems that may be sources of contamination. Comply with authorities having jurisdiction.
1. Locate backflow preventers in same room as connected equipment or system.
 2. Install drain for backflow preventers with atmospheric-vent drain connection with air-gap fitting, fixed air-gap fitting, or equivalent positive pipe separation of at least two pipe diameters in drain piping and pipe to floor drain. Locate air-gap device attached to or under backflow preventer. Simple air breaks are not acceptable for this application.
 3. Do not install bypass piping around backflow preventers.
- C. Install water regulators with inlet and outlet shutoff valves. Install pressure gages on inlet and outlet.

- D. Install water control valves with inlet and outlet shutoff valves. Install pressure gages on inlet and outlet.
- E. Install balancing valves in locations where they can easily be adjusted.
- F. Install temperature-actuated water mixing valves with check stops or shutoff valves on inlets and with shutoff valve on outlet.
 - 1. Install thermometers and water regulators if specified.
 - 2. Install cabinet-type units recessed in or surface mounted on wall as specified.
- G. Install Y-pattern strainers for water on supply side of each control valve, solenoid valve, and pump.
- H. Install outlet boxes recessed in wall. Install 2-by-4-inch fire-retardant-treated-wood blocking wall reinforcement between studs. Fire-retardant-treated-wood blocking is specified in Division 06 Section "Rough Carpentry."
- I. Install hose stations with check stops or shutoff valves on inlets and with thermometer on outlet.
 - 1. Install shutoff valve on outlet if specified.
 - 2. Install cabinet-type units recessed in or surface mounted on wall as specified. Install 2-by-4-inch fire-retardant-treated-wood blocking wall reinforcement between studs. Fire-retardant-treated-wood blocking is specified in Division 06 Section "Rough Carpentry."
- J. Install freeze-resistant yard hydrants with riser pipe set in concrete or pavement. Do not encase canister in concrete.
- K. Install water hammer arresters in water piping according to PDI-WH 201.
- L. Install air vents at high points of water piping. Install drain piping and discharge onto floor drain.
- M. Install supply-type, trap-seal primer valves with outlet piping pitched down toward drain trap a minimum of 1 percent, and connect to floor-drain body, trap, or inlet fitting. Adjust valve for proper flow.
- N. Install drainage-type, trap-seal primer valves as lavatory trap with outlet piping pitched down toward drain trap a minimum of 1 percent, and connect to floor-drain body, trap, or inlet fitting.
- O. Install trap-seal primer systems with outlet piping pitched down toward drain trap a minimum of 1 percent, and connect to floor-drain body, trap, or inlet fitting. Adjust system for proper flow.

3.02 CONNECTIONS

- A. Piping installation requirements are specified in other Division 22 Sections. Drawings indicate general arrangement of piping and specialties.
- B. Ground equipment according to Division 26 Section "Grounding and Bonding for Electrical Systems."
- C. Connect wiring according to Division 26 Section "Low-Voltage Electrical Power Conductors and Cables."

3.03 LABELING AND IDENTIFYING

- A. Equipment Nameplates and Signs: Install engraved plastic-laminate equipment nameplate or sign on or near each of the following:
 - 1. Pressure vacuum breakers.
 - 2. Intermediate atmospheric-vent backflow preventers.
 - 3. Reduced-pressure-principle backflow preventers.
 - 4. Reduced-pressure-detector, fire-protection backflow-preventer assemblies.

5. Water pressure-reducing valves.
 6. Calibrated balancing valves.
 7. Primary, thermostatic, water mixing valves.
 8. Primary water tempering valves.
 9. Outlet boxes.
 10. Hose stations.
 11. Supply-type, trap-seal primer valves.
- B. Distinguish among multiple units, inform operator of operational requirements, indicate safety and emergency precautions, and warn of hazards and improper operations, in addition to identifying unit. Nameplates and signs are specified in Division 22 Section "Identification for Plumbing Piping and Equipment."

3.04 FIELD QUALITY CONTROL

- A. Perform the following tests and prepare test reports:
1. Test each pressure vacuum breaker reduced-pressure-principle backflow preventer double-check, detector-assembly backflow preventer according to authorities having jurisdiction and the device's reference standard.
- B. Remove and replace malfunctioning domestic water piping specialties and retest as specified above.

3.05 ADJUSTING

- A. Set field-adjustable pressure set points of water pressure-reducing valves.
- B. Set field-adjustable flow set points of balancing valves.
- C. Set field-adjustable temperature set points of temperature-actuated water mixing valves.

END OF SECTION

SECTION 221316 - SANITARY WASTE AND VENT PIPING

PART 1 - GENERAL

1.01 RELATED DOCUMENTS

- A. Drawings and general provisions of the Contract, including General and Supplementary Conditions and Division 01 Specification Sections, apply to this Section.

1.02 SUMMARY

- A. This Section includes the following for soil, waste, and vent piping inside the building:
 - 1. Pipe, tube, and fittings.
 - 2. Special pipe fittings.
 - 3. Encasement for underground metal piping.
- B. Related Sections include the following:
 - 1. Division 22 Section "Chemical Waste-Systems for Laboratory Facilities" for chemical-waste and vent piping systems.

1.03 DEFINITIONS

- A. ABS: Acrylonitrile-butadiene-styrene plastic.
- B. EPDM: Ethylene-propylene-diene terpolymer rubber.
- C. LLDPE: Linear, low-density polyethylene plastic.
- D. NBR: Acrylonitrile-butadiene rubber.
- E. PE: Polyethylene plastic.
- F. PVC: Polyvinyl chloride plastic.
- G. TPE: Thermoplastic elastomer.

1.04 PERFORMANCE REQUIREMENTS

- A. Components and installation shall be capable of withstanding the following minimum working pressure, unless otherwise indicated:
 - 1. Soil, Waste, and Vent Piping: 10-foot head of water.
 - 2. Sanitary Sewer, Force-Main Piping: 100 psig.

1.05 SUBMITTALS

- A. Product Data: For pipe, tube, fittings, and couplings.
- B. LEED Submittal:
 - 1. Product Data for Credit EQ 4.1: For solvent cements and adhesive primers, including printed statement of VOC content.
- C. Field quality-control inspection and test reports.

1.06 QUALITY ASSURANCE

- A. Piping materials shall bear label, stamp, or other markings of specified testing agency.
- B. Comply with NSF 14, "Plastics Piping Systems Components and Related Materials," for plastic piping components. Include marking with "NSF-dwv" for plastic drain, waste, and vent piping; "NSF-drain" for plastic drain piping; "NSF-tubular" for plastic continuous waste piping; and "NSF-sewer" for plastic sewer piping.

PART 2 - PRODUCTS

2.01 MANUFACTURERS

- A. In other Part 2 articles where titles below introduce lists, the following requirements apply to product selection:
 - 1. Available Manufacturers: Subject to compliance with requirements, manufacturers offering products that may be incorporated into the Work include, but are not limited to, manufacturers specified.
 - 2. Manufacturers: Subject to compliance with requirements, provide products by one of the manufacturers specified.

2.02 PIPING MATERIALS

- A. Refer to Part 3 "Piping Applications" Article for applications of pipe, tube, fitting, and joining materials.

2.03 PVC SOIL PIPE AND FITTINGS (Below ground application)

- A. Underground, soil, waste, and vent piping NPS 6 and smaller shall be the following:
 - 1. PVC Pipe: Schedule 40 PVC, conform to ASTM D-1785 Soil and Waste Vent piping. Fittings shall be compatible material with solvent cement type joints.
 - 2. PVC Socket Fittings: ASTM D 2665, made to ASTM D 3311 drain, waste, and vent pipe patterns with solvent-cemented joints.

2.04 HUBLESS CAST-IRON SOIL PIPE AND FITTINGS (above ground application)

- A. Pipe and Fittings: ASTM A 888 or CISPI 301.
- B. Solvent Stack Fittings: ASME B16.45 or ASSE 1043, hubless, cast-iron aerator and deaerator drainage fittings.
- C. Shielded Couplings: ASTM C 1277 assembly of metal shield or housing, corrosion-resistant fasteners, and rubber sleeve with integral, center pipe stop.
 - 1. Standard, Shielded, Stainless-Steel Couplings: CISPI 310, with stainless-steel corrugated shield; stainless-steel bands and tightening devices; and ASTM C 564, rubber sleeve.
 - a. Manufacturers:
 - (1) ANACO.
 - (2) Fernco, Inc.
 - (3) Ideal Div.; Stant Corp.
 - (4) Mission Rubber Co.
 - (5) Tyler Pipe; Soil Pipe Div.

2.05 SPECIAL PIPE FITTINGS

- A. Flexible, Non-pressure Pipe Couplings: Comply with ASTM C 1173, elastomeric, sleeve-type, reducing or transition pattern. Include shear ring, ends of same sizes as piping to be joined, and corrosion-resistant-metal tension band and tightening mechanism on each end.
 - 1. Manufacturers:
 - a. Dallas Specialty & Mfg. Co.
 - b. Fernco, Inc.
 - c. Logan Clay Products Company (The).
 - d. Mission Rubber Co.
 - e. NDS, Inc.
 - f. Plastic Oddities, Inc.

2. Sleeve Materials:
 - a. For Cast-Iron Soil Pipes: ASTM C 564, rubber.
 - b. For Plastic Pipes: ASTM F 477, elastomeric seal or ASTM D 5926, PVC.
 - c. For Dissimilar Pipes: ASTM D 5926, PVC or other material compatible with pipe materials being joined.
- B. Shielded Non-pressure Pipe Couplings: ASTM C 1460, elastomeric or rubber sleeve with full-length, corrosion-resistant outer shield and corrosion-resistant-metal tension band and tightening mechanism on each end.
 1. Manufacturers:
 - a. Cascade Waterworks Mfg. Co.
 - b. Mission Rubber Co.
- C. Rigid, Unshielded, Non-pressure Pipe Couplings: ASTM C 1461, sleeve-type reducing- or transition-type mechanical coupling molded from ASTM C 1440, TPE material with corrosion-resistant-metal tension band and tightening mechanism on each end.
 1. Manufacturers:
 - a. ANACO.

PART 3 - EXECUTION

3.01 EXCAVATION

- A. Refer to Division 31 Section "Earth Moving" for excavating, trenching, and backfilling.

3.02 PIPING APPLICATIONS

- A. Flanges and unions may be used on aboveground pressure piping, unless otherwise indicated.
- B. Aboveground, soil and waste piping NPS 4 and smaller shall be the following:
 1. Service class, cast-iron soil pipe and fittings; gaskets; and gasketed joints.
 2. Hubless cast-iron soil pipe and fittings and solvent stack fittings; standard, shielded, stainless-steel couplings; and hubless-coupling joints.
- C. Aboveground, soil and waste piping NPS 5 and larger shall be the following:
 1. Service class, cast-iron soil pipe and fittings; gaskets; and gasketed joints.
 2. Hubless cast-iron soil pipe and fittings; standard, shielded, stainless-steel couplings; and hubless-coupling joints.
- D. Aboveground, vent piping NPS 4 and smaller shall be the following:
 1. Service class, cast-iron soil pipe and fittings; gaskets; and gasketed joints.
 2. Hubless cast-iron soil pipe and fittings; standard, shielded, stainless-steel couplings; and hubless-coupling joints.
 3. Copper DWV tube, copper drainage fittings, and soldered joints.
 - a. Option for Vent Piping, NPS 2-1/2 and NPS 3-1/2: Hard copper tube, Type M; copper pressure fittings; and soldered joints.
- E. Underground, soil, waste, and vent piping NPS 5 and smaller shall be the following:
 1. Cellular-core, Sewer and Drain Series, PVC pipe; PVC socket fittings; and solvent-cemented joints.

3.03 PIPING INSTALLATION

- A. Sanitary sewer piping outside the building is specified in Division 22 Section "Facility Sanitary Sewers."

- B. Basic piping installation requirements are specified in Division 22 Section "Common Work Results for Plumbing."
- C. Install cleanouts at grade and extend to where building sanitary drains connect to building sanitary sewers.
- D. Install cleanout fitting with closure plug inside the building in sanitary force-main piping.
- E. Install cast-iron sleeve with water stop and mechanical sleeve seal at each service pipe penetration through foundation wall. Select number of interlocking rubber links required to make installation watertight. Sleeves and mechanical sleeve seals are specified in Division 22 Section "Common Work Results for Plumbing."
- F. Install wall-penetration fitting at each service pipe penetration through foundation wall. Make installation watertight.
- G. Install cast-iron soil piping according to CISPI's "Cast Iron Soil Pipe and Fittings Handbook," Chapter IV, "Installation of Cast Iron Soil Pipe and Fittings."
 - 1. Install encasement on underground piping according to ASTM A 674 or AWWA C105.
- H. Make changes in direction for soil and waste drainage and vent piping using appropriate branches, bends, and long-sweep bends. Sanitary tees and short-sweep 1/4 bends may be used on vertical stacks if change in direction of flow is from horizontal to vertical. Use long-turn, double Y-branch and 1/8-bend fittings if 2 fixtures are installed back to back or side by side with common drain pipe. Straight tees, elbows, and crosses may be used on vent lines. Do not change direction of flow more than 90 degrees. Use proper size of standard increasers and reducers if pipes of different sizes are connected. Reducing size of drainage piping in direction of flow is prohibited.
- I. Lay buried building drainage piping beginning at low point of each system. Install true to grades and alignment indicated, with unbroken continuity of invert. Place hub ends of piping upstream. Install required gaskets according to manufacturer's written instructions for use of lubricants, cements, and other installation requirements. Maintain swab in piping and pull past each joint as completed.
- J. Install soil and waste drainage and vent piping at the following minimum slopes, unless otherwise indicated:
 - 1. Building Sanitary Drain: 2 percent downward in direction of flow for piping NPS 2 and smaller; 1 percent downward in direction of flow for piping NPS 3 and larger.
 - 2. Horizontal Sanitary Drainage Piping: 1 percent downward in direction of flow.
 - 3. Vent Piping: 1 percent down toward vertical fixture vent or toward vent stack.
- K. Sleeves are not required for cast-iron soil piping passing through concrete slabs-on-grade if slab is without membrane waterproofing.
- L. Install PVC soil and waste drainage and vent piping according to ASTM D 2665.
- M. Install underground PVC soil and waste drainage piping according to ASTM D 2321.
- N. Do not enclose, cover, or put piping into operation until it is inspected and approved by authorities having jurisdiction.

3.04 JOINT CONSTRUCTION

- A. Basic piping joint construction requirements are specified in Division 22 Section "Common Work Results for Plumbing."
- B. Join hub-and-spigot, cast-iron soil piping with gasket joints according to CISPI's "Cast Iron Soil Pipe and Fittings Handbook" for compression joints.

- C. Join hub-and-spigot, cast-iron soil piping with calked joints according to CISPI's "Cast Iron Soil Pipe and Fittings Handbook" for lead and oakum calked joints.
- D. Join hubless cast-iron soil piping according to CISPI 310 and CISPI's "Cast Iron Soil Pipe and Fittings Handbook" for hubless-coupling joints.
- E. PVC Nonpressure Piping Joints: Join piping according to ASTM D 2665.

3.05 HANGER AND SUPPORT INSTALLATION

- A. Pipe hangers and supports are specified in Division 22 Section "Hangers and Supports for Plumbing Piping and Equipment." Install the following:
 - 1. Vertical Piping: MSS Type 8 or Type 42, clamps.
 - 2. Install individual, straight, horizontal piping runs according to the following:
 - a. 100 Feet and Less: MSS Type 1, adjustable, steel clevis hangers.
 - b. Longer Than 100 Feet: MSS Type 43, adjustable roller hangers.
 - c. Longer Than 100 Feet, if Indicated: MSS Type 49, spring cushion rolls.
 - 3. Multiple, Straight, Horizontal Piping Runs 100 Feet or Longer: MSS Type 44, pipe rolls. Support pipe rolls on trapeze.
 - 4. Base of Vertical Piping: MSS Type 52, spring hangers.
- B. Install supports according to Division 22 Section "Hangers and Supports for Plumbing Piping and Equipment."
- C. Support vertical piping and tubing at base and at each floor.
- D. Rod diameter may be reduced 1 size for double-rod hangers, with 3/8-inch minimum rods.
- E. Install hangers for cast-iron soil piping with the following maximum horizontal spacing and minimum rod diameters:
 - 1. NPS 1-1/2 and NPS 2: 60 inches with 3/8-inch rod.
 - 2. NPS 3: 60 inches with 1/2-inch rod.
 - 3. NPS 4 and NPS 5: 60 inches with 5/8-inch rod.
 - 4. NPS 6: 60 inches with 3/4-inch rod.
 - 5. NPS 8 to NPS 12: 60 inches with 7/8-inch rod.
- F. Install supports for vertical cast-iron soil piping every 15 feet.
- G. Install hangers for PVC piping with the following maximum horizontal spacing and minimum rod diameters:
 - 1. NPS 1-1/2 and NPS 2: 48 inches with 3/8-inch rod.
 - 2. NPS 3: 48 inches with 1/2-inch rod.
 - 3. NPS 4 and 5: 48 inches with 5/8-inch rod.
 - 4. NPS 6: 48 inches with 3/4-inch rod.
 - 5. NPS 8 to NPS 12: 48 inches with 7/8-inch rod.
- H. Install supports for vertical PVC piping every 48 inches.
- I. Support piping and tubing not listed above according to MSS SP-69 and manufacturer's written instructions.

3.06 CONNECTIONS

- A. Drawings indicate general arrangement of piping, fittings, and specialties.
- B. Connect soil and waste piping to exterior sanitary sewerage piping. Use transition fitting to join dissimilar piping materials.

- C. Connect drainage and vent piping to the following:
 - 1. Plumbing Fixtures: Connect drainage piping in sizes indicated, but not smaller than required by plumbing code.
 - 2. Plumbing Fixtures and Equipment: Connect atmospheric vent piping in sizes indicated, but not smaller than required by authorities having jurisdiction.
 - 3. Plumbing Specialties: Connect drainage and vent piping in sizes indicated, but not smaller than required by plumbing code.
 - 4. Equipment: Connect drainage piping as indicated. Provide shutoff valve, if indicated, and union for each connection. Use flanges instead of unions for connections NPS 2-1/2 and larger.

3.07 FIELD QUALITY CONTROL

- A. During installation, notify authorities having jurisdiction at least 24 hours before inspection must be made. Perform tests specified below in presence of authorities having jurisdiction.
 - 1. Roughing-in Inspection: Arrange for inspection of piping before concealing or closing-in after roughing-in and before setting fixtures.
 - 2. Final Inspection: Arrange for final inspection by authorities having jurisdiction to observe tests specified below and to ensure compliance with requirements.
- B. Re-inspection: If authorities having jurisdiction find that piping will not pass test or inspection, make required corrections and arrange for re-inspection.
- C. Reports: Prepare inspection reports and have them signed by authorities having jurisdiction.
- D. Test sanitary drainage and vent piping according to procedures of authorities having jurisdiction or, in absence of published procedures, as follows:
 - 1. Test for leaks and defects in new piping and parts of existing piping that have been altered, extended, or repaired. If testing is performed in segments, submit separate report for each test, complete with diagram of portion of piping tested.
 - 2. Leave uncovered and unconcealed new, altered, extended, or replaced drainage and vent piping until it has been tested and approved. Expose work that was covered or concealed before it was tested.
 - 3. Roughing-in Plumbing Test Procedure: Test drainage and vent piping, except outside leaders, on completion of roughing-in. Close openings in piping system and fill with water to point of overflow, but not less than 10-foot head of water. From 15 minutes before inspection starts to completion of inspection, water level must not drop. Inspect joints for leaks.
 - 4. Finished Plumbing Test Procedure: After plumbing fixtures have been set and traps filled with water, test connections and prove they are gastight and watertight. Plug vent-stack openings on roof and building drains where they leave building. Introduce air into piping system equal to pressure of 1-inch wg. Use U-tube or manometer inserted in trap of water closet to measure this pressure. Air pressure must remain constant without introducing additional air throughout period of inspection. Inspect plumbing fixture connections for gas and water leaks.
 - 5. Repair leaks and defects with new materials and retest piping, or portion thereof, until satisfactory results are obtained.
 - 6. Prepare reports for tests and required corrective action.
 - 7. Isolate test source and allow to stand for four hours. Leaks and loss in test pressure constitute defects that must be repaired.
 - 8. Repair leaks and defects with new materials and retest piping, or portion thereof, until satisfactory results are obtained.

9. Prepare reports for tests and required corrective action.

3.08 CLEANING

- A. Clean interior of piping. Remove dirt and debris as work progresses.
- B. Protect drains during remainder of construction period to avoid clogging with dirt and debris and to prevent damage from traffic and construction work.
- C. Place plugs in ends of uncompleted piping at end of day and when work stops.

3.09 PROTECTION

- A. Exposed PVC Piping: Protect plumbing vents exposed to sunlight with two coats of water-based latex paint.
- B. All grease traps must have lid liners for odor control.

END OF SECTION

SECTION 221319 - SANITARY WASTE PIPING SPECIALTIES

PART 1 – GENERAL

1.01 RELATED DOCUMENTS

- A. Drawings and general provisions of the Contract, including General and Supplementary Conditions and Division 01 Specification Sections, apply to this Section.

1.02 SUMMARY

- A. This Section includes the following sanitary drainage piping specialties:
 - 1. Backwater valves.
 - 2. Cleanouts.
 - 3. Floor drains.
 - 4. Trench drains.
 - 5. Roof flashing assemblies.
 - 6. Through-penetration fire stop assemblies.
 - 7. Miscellaneous sanitary drainage piping specialties.
 - 8. Flashing materials.
 - 9. Neutralization tanks.

1.03 DEFINITIONS

- A. ABS: Acrylonitrile-butadiene-styrene plastic.
- B. FOG: Fats, oils, and greases.
- C. FRP: Fiberglass-reinforced plastic.
- D. HDPE: High-density polyethylene plastic.
- E. PE: Polyethylene plastic.
- F. PP: Polypropylene plastic.
- G. PVC: Polyvinyl chloride plastic.

1.04 SUBMITTALS

- A. Product Data: For each type of product indicated. Include rated capacities, operating characteristics, and accessories for the following:
 - 1. Neutralization tanks.
- B. Shop Drawings: Show fabrication and installation details for frost-resistant vent terminals.
 - 1. Show fabrication and installation details for frost-resistant vent terminals.
 - 2. Dimensioned Outline Drawings of Equipment Unit: Identify center of gravity and locate and describe mounting and anchorage provisions.
 - 3. Detailed description of equipment anchorage devices on which the certification is based and their installation requirements.
- C. Field quality-control test reports.
- D. Operation and Maintenance Data: For drainage piping specialties to include in emergency, operation, and maintenance manuals.

1.05 QUALITY ASSURANCE

- A. Drainage piping specialties shall bear label, stamp, or other markings of specified testing agency.

1.06 COORDINATION

- A. Coordinate size and location of concrete bases. Cast anchor-bolt inserts into bases. Concrete, reinforcement, and formwork requirements are specified in Division 03.
- B. Coordinate size and location of roof penetrations.

PART 2 - PRODUCTS

2.01 CLEANOUTS

- A. Exposed Metal Cleanouts:
 - 1. Available Manufacturers: Subject to compliance with requirements, manufacturers offering products that may be incorporated into the Work include, but are not limited to, the following:
 - 2. Manufacturers: Subject to compliance with requirements, provide products by one of the following:
 - a. Josam Company; Josam Div.
 - b. MIFAB, Inc.
 - c. Smith, Jay R. Mfg. Co.; Division of Smith Industries, Inc.
 - d. Tyler Pipe; Wade Div.
 - e. Watts Drainage Products Inc.
 - f. Zurn Plumbing Products Group; Specification Drainage Operation.
 - g. Josam Company; Blucher-Josam Div.
 - 3. Standard: ASME A112.36.2M for cast iron for cleanout test tee.
 - 4. Size: Same as connected drainage piping
 - 5. Body Material: Cast-iron soil pipe test tee as required to match connected piping.
 - 6. Closure: Countersunk plug.
 - 7. Closure Plug Size: Same as or not more than one size smaller than cleanout size.
 - 8. Closure: Stainless-steel plug with seal.
- B. Metal Floor Cleanouts:
 - 1. Manufacturers: Subject to compliance with requirements, provide products by one of the following:
 - a. Josam Company; Josam Div.
 - b. Oatey.
 - c. Sioux Chief Manufacturing Company, Inc.
 - d. Smith, Jay R. Mfg. Co.; Division of Smith Industries, Inc.
 - e. Tyler Pipe; Wade Div.
 - f. Watts Drainage Products Inc.
 - g. Zurn Plumbing Products Group; Light Commercial Operation.
 - h. Zurn Plumbing Products Group; Specification Drainage Operation.
 - i. Josam Company; Josam Div.
 - j. Kusel Equipment Co.
 - k. Smith, Jay R. Mfg. Co.; Division of Smith Industries, Inc.
 - l. Josam Company; Blucher-Josam Div.
 - 2. Standard: ASME A112.36.2M for adjustable housing cast-iron soil pipe with cast-iron ferrule heavy-duty, adjustable housing threaded, adjustable housing cleanout.
 - 3. Size: Same as connected branch.
- C. Cast-Iron Wall Cleanouts:
 - 1. Manufacturers: Subject to compliance with requirements, provide products by one of the following:
 - a. Josam Company; Josam Div.
 - b. MIFAB, Inc.
 - c. Smith, Jay R. Mfg. Co.; Division of Smith Industries, Inc.
 - d. Tyler Pipe; Wade Div.
 - e. Watts Drainage Products Inc.
 - f. Zurn Plumbing Products Group; Specification Drainage Operation.
 - 2. Standard: ASME A112.36.2M. Include wall access.
 - 3. Size: Same as connected drainage piping.
 - 4. Body: Hubless, cast-iron soil pipe test tee as required to match connected piping.
 - 5. Size: Same as connected branch.
 - 6. Body: PVC.
 - 7. Closure Plug: PVC.

8. Riser: Drainage pipe fitting and riser to cleanout of same material as drainage piping.

2.02 FLOOR DRAINS

A. Cast-Iron Floor Drains:

1. Manufacturers: Subject to compliance with requirements, provide products by one of the following:
 - a. Josam Company; Josam Div.
 - b. MIFAB, Inc.
 - c. Prier Products, Inc.
 - d. Smith, Jay R. Mfg. Co.; Division of Smith Industries, Inc.
 - e. Tyler Pipe; Wade Div.
 - f. Watts Drainage Products Inc.
 - g. Zurn Plumbing Products Group; Light Commercial Operation.
 - h. Zurn Plumbing Products Group; Specification Drainage Operation.
2. Standard: ASME A112.6.3.
3. Pattern: Sanitary drain.
4. Body Material: Gray iron.

B. Wall Box:

1. Manufacturers: Subject to compliance with requirements, provide products by one of the following:
 - a. Durgo, Inc.
 - b. Oatey.
 - c. RectorSeal.
 - d. Studor, Inc.
2. Description: White plastic housing with white plastic grille, made for recessed installation. Include bottom pipe connection and space to contain one air-admittance valve.
3. Size: About 9 inches wide by 8 inches high by 4 inches deep.

2.03 ROOF FLASHING ASSEMBLIES

A. Roof Flashing Assemblies:

1. Manufacturers: Subject to compliance with requirements, provide products by one of the following:
 - a. Acorn Engineering Company; Elmdor/Stoneman Div.
 - b. Thaler Metal Industries Ltd.

B. Description: Manufactured assembly made of from pipe, with galvanized-steel boot reinforcement and counter flashing fitting.

1. Open-Top Vent Cap: Without cap.
2. Low-Silhouette Vent Cap: With vandal-proof vent cap.
3. Extended Vent Cap: With field-installed, vandal-proof vent cap.

2.04 THROUGH-PENETRATION FIRESTOP ASSEMBLIES

A. Through-Penetration Firestop Assemblies:

1. Manufacturers: Subject to compliance with requirements, provide products by one of the following:
 - a. ProSet Systems Inc.
2. Standard: UL 1479 assembly of sleeve and stack fitting with firestopping plug.
3. Size: Same as connected soil, waste, or vent stack.
4. Sleeve: Molded PVC plastic, of length to match slab thickness and with integral nailing flange on one end for installation in cast-in-place concrete slabs.
5. Stack Fitting: ASTM A 48/A 48M, gray-iron, hubless-pattern, wye branch with neoprene O-ring at base and gray-iron plug in thermal-release harness. Include PVC protective cap for plug.
6. Special Coating: Corrosion resistant on interior of fittings.

2.05 MISCELLANEOUS SANITARY DRAINAGE PIPING SPECIALTIES

A. Open Drains:

1. Description: Shop or field fabricate from ASTM A 74, Service class, hub-and-spigot, cast-iron, soil-pipe fittings. Include P-trap, hub-and-spigot riser section; and where required, increaser fitting joined with ASTM C 564, rubber gaskets.
 2. Size: Same as connected waste piping.
- B. Deep-Seal Traps:
1. Description: Cast-iron or bronze casting, with inlet and outlet matching connected piping and cleanout trap-seal primer valve connection.
 2. Size: Same as connected waste piping.
 - a. NPS 2: 4-inch- minimum water seal.
 - b. NPS 2-1/2 and Larger: 5-inch- minimum water seal.
- C. Floor-Drain, Trap-Seal Primer Fittings:
1. Description: Cast iron, with threaded inlet and threaded or spigot outlet, and trap-seal primer valve connection.
 2. Size: Same as floor drain outlet with NPS 1/2 side inlet.
- D. Air-Gap Fittings:
1. Standard: ASME A112.1.2, for fitting designed to ensure fixed, positive air gap between installed inlet and outlet piping.
 2. Body: Bronze or cast iron.
 3. Inlet: Opening in top of body.
 4. Outlet: Larger than inlet.
 5. Size: Same as connected waste piping and with inlet large enough for associated indirect waste piping.
- E. Sleeve Flashing Device:
1. Description: Manufactured, cast-iron fitting, with clamping device, that forms sleeve for pipe floor penetrations of floor membrane. Include galvanized-steel pipe extension in top of fitting that will extend 2 inches above finished floor and galvanized-steel pipe extension in bottom of fitting that will extend through floor slab.
 2. Size: As required for close fit to riser or stack piping.
- F. Stack Flashing Fittings:
1. Description: Counter flashing-type, cast-iron fitting, with bottom recess for terminating roof membrane, and with threaded or hub top for extending vent pipe.
 2. Size: Same as connected stack vent or vent stack.
- G. Vent Caps:
1. Description: Cast-iron body with threaded or hub inlet and vandal-proof design. Include vented hood and setscrews to secure to vent pipe.
 2. Size: Same as connected stack vent or vent stack.
- H. Frost-Resistant Vent Terminals:
1. Description: Manufactured or shop-fabricated assembly constructed of copper, lead-coated copper, or galvanized steel.
 2. Design: To provide 1-inch enclosed air space between outside of pipe and inside of flashing collar extension, with counter flashing.
- I. Expansion Joints:
1. Standard: ASME A112.21.2M.
 2. Body: Cast iron with bronze sleeve, packing, and gland.
 3. End Connections: Matching connected piping.
 4. Size: Same as connected soil, waste, or vent piping.

2.06 FLASHING MATERIALS

- A. Lead Sheet: ASTM B 749, Type L51121, copper bearing, with the following minimum weights and thicknesses, unless otherwise indicated:
1. General Use: 4.0-lb/sq. ft., 0.0625-inch thickness.
 2. Vent Pipe Flashing: 3.0-lb/sq. ft., 0.0469-inch thickness.
 3. Burning: 6-lb/sq. ft., 0.0938-inch thickness.

- B. Copper Sheet: ASTM B 152/B 152M, of the following minimum weights and thicknesses, unless otherwise indicated:
 - 1. General Applications: 12 oz/sq. ft.
 - 2. Vent Pipe Flashing: 8 oz/sq. ft.
- C. Zinc-Coated Steel Sheet: ASTM A 653/A 653M, with 0.20 percent copper content and 0.04-inch minimum thickness, unless otherwise indicated. Include G90 hot-dip galvanized, mill-phosphatized finish for painting if indicated.
- D. Elastic Membrane Sheet: ASTM D 4068, flexible, chlorinated polyethylene, 40-mil minimum thickness.
- E. Fasteners: Metal compatible with material and substrate being fastened.
- F. Metal Accessories: Sheet metal strips, clamps, anchoring devices, and similar accessory units required for installation; matching or compatible with material being installed.
- G. Solder: ASTM B 32, lead-free alloy.
- H. Bituminous Coating: SSPC-Paint 12, solvent-type, bituminous mastic.

PART 3 - EXECUTION

3.01 INSTALLATION

- A. Install backwater valves in building drain piping. For interior installation, provide cleanout deck plate flush with floor and centered over backwater valve cover, and of adequate size to remove valve cover for servicing.
- B. Install cleanouts in aboveground piping and building drain piping according to the following, unless otherwise indicated:
 - 1. Size same as drainage piping up to NPS 4. Use NPS 4 for larger drainage piping unless larger cleanout is indicated.
 - 2. Locate at each change in direction of piping greater than 45 degrees.
 - 3. Locate at minimum intervals of 75 feet for piping NPS 4 and smaller and 100 feet for larger piping.
 - 4. Locate at base of each vertical soil and waste stack.
- C. For floor cleanouts for piping below floors, install cleanout deck plates with top flush with finished floor.
- D. For cleanouts located in concealed piping, install cleanout wall access covers, of types indicated, with frame and cover flush with finished wall.
- E. Install floor drains at low points of surface areas to be drained. Set grates of drains flush with finished floor, unless otherwise indicated.
 - 1. Position floor drains for easy access and maintenance.
 - 2. Set floor drains below elevation of surrounding finished floor to allow floor drainage. Set with grates depressed according to the following drainage area radii:
 - a. Radius, 30 Inches or Less: Equivalent to 1 percent slope, but not less than 1/4-inch total depression.
 - b. Radius, 30 to 60 Inches: Equivalent to 1 percent slope.
 - c. Radius, 60 Inches or Larger: Equivalent to 1 percent slope, but not greater than 1-inch total depression.
 - 3. Install floor-drain flashing collar or flange so no leakage occurs between drain and adjoining flooring. Maintain integrity of waterproof membranes where penetrated.
 - 4. Install individual traps for floor drains connected to sanitary building drain, unless otherwise indicated.
- F. Install roof flashing assemblies on sanitary stack vents and vent stacks that extend through roof.
- G. Install flashing fittings on sanitary stack vents and vent stacks that extend through roof.
- H. Install through-penetration firestop assemblies in plastic stacks at floor penetrations.
- I. Assemble open drain fittings and install with top of hub 2 inches above floor.
- J. Install deep-seal traps on floor drains and other waste outlets, as required.
- K. Install floor-drain, trap-seal primer fittings on inlet to floor drains that require trap-seal primer connection.
 - 1. Exception: Fitting may be omitted if trap has trap-seal primer connection.
 - 2. Size: Same as floor drain inlet.
- L. Install air-gap fittings on draining-type backflow preventers and on indirect-waste piping discharge into sanitary drainage system.

- M. Install sleeve flashing device with each riser and stack passing through floors with waterproof membrane.
- N. Install vent caps on each vent pipe passing through roof.
- O. Install frost-resistant vent terminals on each vent pipe passing through roof. Maintain 1-inch clearance between vent pipe and roof substrate.
- P. Install expansion joints on vertical stacks and conductors. Position expansion joints for easy access and maintenance.
- Q. Install frost-proof vent caps on each vent pipe passing through roof. Maintain 1-inch clearance between vent pipe and roof substrate.

3.02 FLASHING INSTALLATION

- A. Fabricate flashing from single piece unless large pans, sumps, or other drainage shapes are required. Join flashing according to the following if required:
 - 1. Lead Sheets: Burn joints of lead sheets 6.0-lb/sq. ft, 0.0938-inch thickness or thicker. Solder joints of lead sheets 4.0-lb/sq. ft 0.0625-inch thickness or thinner.
 - 2. Copper Sheets: Solder joints of copper sheets.
- B. Install sheet flashing on pipes, sleeves, and specialties passing through or embedded in floors and roofs with waterproof membrane.
 - 1. Pipe Flashing: Sleeve type, matching pipe size, with minimum length of 10 inches, and skirt or flange extending at least 8 inches around pipe.
 - 2. Sleeve Flashing: Flat sheet, with skirt or flange extending at least 8 inches around sleeve.
 - 3. Embedded Specialty Flashing: Flat sheet, with skirt or flange extending at least 8 inches around specialty.
- C. Set flashing on floors and roofs in solid coating of bituminous cement.
- D. Secure flashing into sleeve and specialty clamping ring or device.
- E. Install flashing for piping passing through roofs with counterflashing or commercially made flashing fittings, according to Division 07 Section "Sheet Metal Flashing and Trim."
- F. Extend flashing up vent pipe passing through roofs and turn down into pipe, or secure flashing into cast-iron sleeve having calking recess.
- G. Fabricate and install flashing and pans, sumps, and other drainage shapes.

3.03 LABELING AND IDENTIFYING

- A. Equipment Nameplates and Signs: Install engraved plastic-laminate equipment nameplate or sign on or near each of the following:
 - 1. Neutralization tanks.
- B. Distinguish among multiple units, inform operator of operational requirements, indicate safety and emergency precautions, and warn of hazards and improper operations, in addition to identifying unit. Nameplates and signs are specified in Division 22 Section "Identification for Plumbing Piping and Equipment."

3.04 FIELD QUALITY CONTROL

- A. Perform tests and inspections and prepare test reports.
 - 1. Manufacturer's Field Service: Engage a factory-authorized service representative to inspect field-assembled Neutralization tanks and their installation, including piping and electrical connections, and to assist in testing.
- B. Tests and Inspections:
 - 1. Leak Test: After installation, charge system and test for leaks. Repair leaks and retest until no leaks exist.
 - 2. Test and adjust controls and safeties. Replace damaged and malfunctioning controls and equipment.

3.05 PROTECTION

- A. Protect drains during remainder of construction period to avoid clogging with dirt or debris and to prevent damage from traffic or construction work.
- B. Place plugs in ends of uncompleted piping at end of each day or when work stops.

SECTION 224000 - PLUMBING FIXTURES

PART 1 - GENERAL

1.01 RELATED DOCUMENTS

- A. Drawings and general provisions of the Contract, including General and Supplementary Conditions and Division 01 Specification Sections, apply to this Section.

1.02 SUMMARY

- A. This Section includes the following conventional plumbing fixtures and related components:
 1. Faucets for lavatories bathtubs bathtub/showers showers and sinks.
 2. Laminar-flow faucet-spout outlets.
 3. Flushometers.
 4. Toilet seats.
 5. Fixture supports.
 6. Interceptors.
 7. Water closets.
 8. Urinals.
 9. Lavatories.
 10. Commercial sinks.
 11. Kitchen sinks.
 12. Service sinks.

1.03 DEFINITIONS

- A. ABS: Acrylonitrile-butadiene-styrene plastic.
- B. Accessible Fixture: Plumbing fixture that can be approached, entered, and used by people with disabilities.
- C. Cast Polymer: Cast-filled-polymer-plastic material. This material includes cultured-marble and solid-surface materials.
- D. Cultured Marble: Cast-filled-polymer-plastic material with surface coating.
- E. Fitting: Device that controls the flow of water into or out of the plumbing fixture. Fittings specified in this Section include supplies and stops, faucets and spouts, shower heads and tub spouts, drains and tailpieces, and traps and waste pipes. Piping and general-duty valves are included where indicated.
- F. FRP: Fiberglass-reinforced plastic.
- G. PMMA: Polymethyl methacrylate (acrylic) plastic.
- H. PVC: Polyvinyl chloride plastic.
- I. Solid Surface: Nonporous, homogeneous, cast-polymer-plastic material with heat-, impact-, scratch-, and stain-resistance qualities.

1.04 SUBMITTALS

- A. Product Data: For each type of plumbing fixture indicated. Include selected fixture and trim, fittings, accessories, appliances, appurtenances, equipment, and supports. Indicate materials and finishes, dimensions, construction details, and flow-control rates.
- B. Shop Drawings: Diagram power, signal, and control wiring.
- C. Operation and Maintenance Data: For plumbing fixtures to include in emergency, operation, and maintenance manuals.
- D. Warranty: Special warranty specified in this Section.

1.05 QUALITY ASSURANCE

- A. Source Limitations: Obtain plumbing fixtures, faucets, and other components of each category through one source from a single manufacturer.
 - 1. Exception: If fixtures, faucets, or other components are not available from a single manufacturer, obtain similar products from other manufacturers specified for that category.
- B. Electrical Components, Devices, and Accessories: Listed and labeled as defined in NFPA 70, Article 100, by a testing agency acceptable to authorities having jurisdiction, and marked for intended use.
- C. Regulatory Requirements: Comply with requirements in ICC A117.1, "Accessible and Usable Buildings and Facilities"; Public Law 90-480, "Architectural Barriers Act"; and Public Law 101-336, "Americans with Disabilities Act"; for plumbing fixtures for people with disabilities.
- D. Regulatory Requirements: Comply with requirements in Public Law 102-486, "Energy Policy Act," about water flow and consumption rates for plumbing fixtures.
- E. NSF Standard: Comply with NSF 61, "Drinking Water System Components--Health Effects," for fixture materials that will be in contact with potable water.
- F. Select combinations of fixtures and trim, faucets, fittings, and other components that are compatible.

1.06 WARRANTY

- A. Special Warranties: Manufacturer's standard form in which manufacturer agrees to repair or replace components of whirlpools that fail in materials or workmanship within specified warranty period.
 - 1. Failures include, but are not limited to, the following:
 - a. Structural failures of unit shell.
 - b. Faulty operation of controls, blowers, pumps, heaters, and timers.
 - c. Deterioration of metals, metal finishes, and other materials beyond normal use.

PART 2 - PRODUCTS

2.01 LAVATORY FAUCETS

- A. Lavatory Faucets:
 - 1. Available Manufacturers: Subject to compliance with requirements, manufacturers offering products that may be incorporated into the Work include, but are not limited to, the following:
 - a. American Standard Companies, Inc.
 - b. Bradley Corporation.
 - c. Chicago Faucets.

- d. Delta Faucet Company.
- e. Eljer.
- f. Elkay Manufacturing Co.
- g. Kohler Co.
- h. Moen, Inc.

2.02 SINK FAUCETS

A. Sink Faucets:

1. Available Manufacturers: Subject to compliance with requirements, manufacturers offering products that may be incorporated into the Work include, but are not limited to, the following:
 - a. American Standard Companies, Inc.
 - b. Bradley Corporation.
 - c. Chicago Faucets.
 - d. Delta Faucet Company.
 - e. Eljer.
 - f. Elkay Manufacturing Co.
 - g. Grohe America, Inc.
 - h. Kohler Co.
 - i. Moen, Inc.
2. Description: Kitchen faucet with spray, three-hole fixture Kitchen faucet with spray, four-hole fixture Kitchen faucet without spray Laundry tray faucet Service sink faucet with stops in shanks, vacuum breaker, hose-thread outlet, and pail hook Bar sink faucet. Include hot- and cold-water indicators; coordinate faucet inlets with supplies and fixture holes; coordinate outlet with spout and fixture receptor.
 - a. Body Material: Commercial, solid brass General-duty, solid brass General-duty, solid brass or copper or brass underbody with brass cover plate General-duty, copper or brass underbody with brass cover plate Residential, nonmetallic underbody with brass cover plate Residential, nonmetallic underbody with nonmetallic cover plate <Insert material>.
 - b. Finish: Polished chrome plate Polished brass Nonmetallic Polished or rough brass Rough brass.

2.03 FLUSHOMETERS

A. Flushometers:

1. Available Manufacturers: Subject to compliance with requirements, manufacturers offering products that may be incorporated into the Work include, but are not limited to, the following:
2. Operating pressure data must be submitted with the fixture shop drawings. Dual Flush valves requiring more than 15 PSI are not acceptable.
 - a. Delta Faucet Company.
 - b. Sloan Valve Company.
 - c. Zurn Plumbing Products Group; Commercial Brass Operation.
 - d. TOTO USA, Inc.

2.04 TOILET SEATS

A. Toilet Seats:

1. Available Manufacturers: Subject to compliance with requirements, manufacturers offering products that may be incorporated into the Work include, but are not limited to, the following:
 - a. American Standard Companies, Inc.
 - b. Bemis Manufacturing Company.
 - c. Church Seats.
 - d. Kohler Co.
 - e. Olsonite Corp.
2. Description: Toilet seat for water-closet-type fixture.
 - a. Material: Molded, solid plastic with antimicrobial agent.
 - b. Configuration: Closed Open front with without cover.
 - c. Size: Elongated.

2.05 FIXTURE SUPPORTS

- A. Available Manufacturers: Subject to compliance with requirements, manufacturers offering products that may be incorporated into the Work include, but are not limited to, the following:
1. Josam Company.
 2. MIFAB Manufacturing Inc.
 3. Smith, Jay R. Mfg. Co.
 4. Tyler Pipe; Wade Div.
 5. Watts Drainage Products Inc.; a div. of Watts Industries, Inc.
 6. Zurn Plumbing Products Group; Specification Drainage Operation.
- B. Water-Closet Supports:
1. Description: Combination carrier designed for accessible standard mounting height of wall-mounting, water-closet-type fixture. Include single or double, vertical or horizontal, hub-and-spigot or hubless waste fitting as required for piping arrangement; faceplates; couplings with gaskets; feet; and fixture bolts and hardware matching fixture. Include additional extension coupling, faceplate, and feet for installation in wide pipe space.
- C. Urinal Supports:
1. Description: Type I, urinal carrier with fixture support plates and coupling with seal and fixture bolts and hardware matching fixture II, urinal carrier with hanger and bearing plates for wall-mounting, urinal-type fixture. Include steel uprights with feet.
 2. Accessible-Fixture Support: Include rectangular steel uprights.
- D. Lavatory Supports:
1. Description: Type I, lavatory carrier with exposed arms and tie rods II, lavatory carrier with concealed arms and tie rod III, lavatory carrier with hanger plate and tie rod for wall-mounting, lavatory-type fixture. Include steel uprights with feet.
 2. Accessible-Fixture Support: Include rectangular steel uprights.
- E. Sink Supports:
1. Description: Type I, sink carrier with exposed arms and tie rods II, sink carrier with hanger plate, bearing studs, and tie rod III, sink carrier with hanger plate and exposed arms for sink-type fixture. Include steel uprights with feet.

2.06 WATER CLOSETS

A. Water Closets:

1. Available Manufacturers: Subject to compliance with requirements, manufacturers offering products that may be incorporated into the Work include, but are not limited to, the following:
 - a. American Standard Companies, Inc.
 - b. Eljer.
 - c. Kohler Co.
 - d. TOTO USA, Inc.

2.07 URINALS

A. Urinals:

1. Available Manufacturers: Subject to compliance with requirements, manufacturers offering products that may be incorporated into the Work include, but are not limited to, the following:
 - a. American Standard Companies, Inc.
 - b. Eljer.
 - c. Kohler Co.
 - d. TOTO USA, Inc.
2. Description: Accessible, wall Wall-mounting, back-outlet, vitreous-china fixture designed for flushometer valve operation.
 - a. Type: Blowout Siphon jet Blowout with extended shields Siphon jet with extended shields Washout with extended shields.
 - b. Strainer or Trapway: Integral cast strainer Separate removable strainer Open trapway with integral trap.
 - c. Design Consumption: 0.5 gal. /flush .
 - d. Color: White .

2.08 LAVATORIES

A. Lavatories, :

1. Available Manufacturers: Subject to compliance with requirements, manufacturers offering products that may be incorporated into the Work include, but are not limited to, the following:
 - a. American Standard Companies, Inc.
 - b. Eljer.
 - c. Kohler Co.
 - d. Eljer.
 - e. TOTO USA, Inc.

2.09 COMMERCIAL SINKS

A. Commercial Sinks:

1. Available Manufacturers: Subject to compliance with requirements, manufacturers offering products that may be incorporated into the Work include, but are not limited to, the following:

- a. Elkay Manufacturing Co.
 - b. Just Manufacturing Company.
 - c. Metal Masters Foodservice Equipment Co., Inc.
2. Description: One or Two compartment, counter-mounting, stainless-steel commercial sink with backsplash.

PART 3 - EXECUTION

3.01 EXAMINATION

- A. Examine roughing-in of water supply and sanitary drainage and vent piping systems to verify actual locations of piping connections before plumbing fixture installation.
- B. Examine cabinets, counters, floors, and walls for suitable conditions where fixtures will be installed.
- C. Proceed with installation only after unsatisfactory conditions have been corrected.

3.02 INSTALLATION

- A. Assemble plumbing fixtures, trim, fittings, and other components according to manufacturers' written instructions.
- B. Install off-floor supports, affixed to building substrate, for wall-mounting fixtures.
 1. Use carrier supports with waste fitting and seal for back-outlet fixtures.
 2. Use carrier supports without waste fitting for fixtures with tubular waste piping.
 3. Use chair-type carrier supports with rectangular steel uprights for accessible fixtures.
- C. Install back-outlet, wall-mounting fixtures onto waste fitting seals and attach to supports.
- D. Install floor-mounting fixtures on closet flanges or other attachments to piping or building substrate.
- E. Install wall-mounting fixtures with tubular waste piping attached to supports.
- F. Install floor-mounting, back-outlet water closets attached to building floor substrate and wall bracket and onto waste fitting seals.
- G. Install counter-mounting fixtures in and attached to casework.
- H. Install fixtures level and plumb according to roughing-in drawings.
- I. Install water-supply piping with stop on each supply to each fixture to be connected to water distribution piping. Attach supplies to supports or substrate within pipe spaces behind fixtures. Install stops in locations where they can be easily reached for operation.
 1. Exception: Use ball, gate, or globe valves if supply stops are not specified with fixture. Valves are specified in Division 22 Section "General-Duty Valves for Plumbing Piping."
- J. Install trap and tubular waste piping on drain outlet of each fixture to be directly connected to sanitary drainage system.
- K. Install tubular waste piping on drain outlet of each fixture to be indirectly connected to drainage system.
- L. Install flushometer valves for accessible water closets and urinals with handle mounted on wide side of compartment. Install other actuators in locations that are easy for people with disabilities to reach.
- M. Install tanks for accessible, tank-type water closets with lever handle mounted on wide side of compartment.

- N. Install toilet seats on water closets.
- O. Install trap-seal liquid in dry urinals.
- P. Install faucet-spout fittings with specified flow rates and patterns in faucet spouts if faucets are not available with required rates and patterns. Include adapters if required.
- Q. Install water-supply flow-control fittings with specified flow rates in fixture supplies at stop valves.
- R. Install faucet flow-control fittings with specified flow rates and patterns in faucet spouts if faucets are not available with required rates and patterns. Include adapters if required.
- S. Install traps on fixture outlets.
 - 1. Exception: Omit trap on fixtures with integral traps.
 - 2. Exception: Omit trap on indirect wastes, unless otherwise indicated.
- T. Install disposer in outlet of each sink indicated to have disposer. Install switch where indicated or in wall adjacent to sink if location is not indicated.
- U. Install escutcheons at piping wall ceiling penetrations in exposed, finished locations and within cabinets and millwork. Use deep-pattern escutcheons if required to conceal protruding fittings. Escutcheons are specified in Division 22 Section "Common Work Results for Plumbing."
- V. Seal joints between fixtures and walls, floors, and countertops using sanitary-type, one-part, mildew-resistant silicone sealant. Match sealant color to fixture color. Sealants are specified in Division 07 Section "Joint Sealants."
- W. Filters shall be accessible on drinking water fountains.

3.03 CONNECTIONS

- A. Piping installation requirements are specified in other Division 22 Sections. Drawings indicate general arrangement of piping, fittings, and specialties.
- B. Connect fixtures with water supplies, stops, and risers, and with traps, soil, waste, and vent piping. Use size fittings required to match fixtures.

3.04 FIELD QUALITY CONTROL

- A. Verify that installed plumbing fixtures are categories and types specified for locations where installed.
- B. Check that plumbing fixtures are complete with trim, faucets, fittings, and other specified components.
- C. Inspect installed plumbing fixtures for damage. Replace damaged fixtures and components.
- D. Test installed fixtures after water systems are pressurized for proper operation. Replace malfunctioning fixtures and components, then retest. Repeat procedure until units operate properly.
- E. Install fresh batteries in sensor-operated mechanisms.

3.05 ADJUSTING

- A. Operate and adjust faucets and controls. Replace damaged and malfunctioning fixtures, fittings, and controls.
- B. Operate and adjust disposers hot-water dispensers and controls. Replace damaged and malfunctioning units and controls.
- C. Adjust water pressure at faucets and flushometer valves to produce proper flow and stream.

- D. Replace washers and seals of leaking and dripping faucets and stops.
- E. Install fresh batteries in sensor-operated mechanisms.

3.06 CLEANING

- A. Clean fixtures, faucets, and other fittings with manufacturers' recommended cleaning methods and materials. Do the following:
 - 1. Remove faucet spouts and strainers, remove sediment and debris, and reinstall strainers and spouts.
 - 2. Remove sediment and debris from drains.
- B. After completing installation of exposed, factory-finished fixtures, faucets, and fittings, inspect exposed finishes and repair damaged finishes.

3.07 PROTECTION

- A. Provide protective covering for installed fixtures and fittings.
- B. Do not allow use of plumbing fixtures for temporary facilities unless approved in writing by Owner.

END OF SECTION

SECTION 230500 - COMMON WORK RESULTS FOR HVAC

PART 1 - GENERAL

1.01 RELATED DOCUMENTS

- A. Drawings and general provisions of the Contract, including General and Supplementary Conditions and Division 01 Specification Sections, apply to this Section.
- B. All HVAC and plumbing work shall comply with applicable codes, industry standards, and local ordinances such as ASME, ASPE, ASTM, NFPA, and ASHRAE.

1.02 SUMMARY

- A. This Section includes the following:
 - 1. Piping materials and installation instructions common to most piping systems.
 - 2. Transition fittings.
 - 3. Dielectric fittings.
 - 4. Mechanical sleeve seals.
 - 5. Sleeves.
 - 6. Escutcheons.
 - 7. Grout.
 - 8. HVAC demolition.
 - 9. Equipment installation requirements common to equipment sections.
 - 10. Painting and finishing.
 - 11. Concrete bases.
 - 12. Supports and anchorages.

1.03 DEFINITIONS

- A. Finished Spaces: Spaces other than mechanical and electrical equipment rooms, furred spaces, pipe and duct chases, unheated spaces immediately below roof, spaces above ceilings, unexcavated spaces, crawlspaces, and tunnels.
- B. Exposed, Interior Installations: Exposed to view indoors. Examples include finished occupied spaces and mechanical equipment rooms.
- C. Exposed, Exterior Installations: Exposed to view outdoors or subject to outdoor ambient temperatures and weather conditions. Examples include rooftop locations.
- D. Concealed, Interior Installations: Concealed from view and protected from physical contact by building occupants. Examples include above ceilings and chases.
- E. Concealed, Exterior Installations: Concealed from view and protected from weather conditions and physical contact by building occupants but subject to outdoor ambient temperatures. Examples include installations within unheated shelters.
- F. The following are industry abbreviations for plastic materials:
 - 1. CPVC: Chlorinated polyvinyl chloride plastic.
 - 2. PE: Polyethylene plastic.
 - 3. PVC: Polyvinyl chloride plastic.

- G. The following are industry abbreviations for rubber materials:
 - 1. EPDM: Ethylene-propylene-diene terpolymer rubber.
 - 2. NBR: Acrylonitrile-butadiene rubber.

1.04 SUBMITTALS

- A. Product Data: For the following:
 - 1. Transition fittings.
 - 2. Dielectric fittings.
 - 3. Mechanical sleeve seals.
 - 4. Escutcheons.
- B. Welding certificates.

1.05 QUALITY ASSURANCE

- A. Steel Support Welding: Qualify processes and operators according to AWS D1.1, "Structural Welding Code--Steel."
- B. Steel Pipe Welding: Qualify processes and operators according to ASME Boiler and Pressure Vessel Code: Section IX, "Welding and Brazing Qualifications."
 - 1. Comply with provisions in ASME B31 Series, "Code for Pressure Piping."
 - 2. Certify that each welder has passed AWS qualification tests for welding processes involved and that certification is current.
- C. Electrical Characteristics for HVAC Equipment: Equipment of higher electrical characteristics may be furnished provided such proposed equipment is approved in writing and connecting electrical services, circuit breakers, and conduit sizes are appropriately modified. If minimum energy ratings or efficiencies are specified, equipment shall comply with requirements.

1.06 DELIVERY, STORAGE, AND HANDLING

- A. Deliver pipes and tubes with factory-applied end caps. Maintain end caps through shipping, storage, and handling to prevent pipe end damage and to prevent entrance of dirt, debris, and moisture.
- B. Store plastic pipes protected from direct sunlight. Support to prevent sagging and bending.

1.07 COORDINATION

- A. Arrange for pipe spaces, chases, slots, and openings in building structure during progress of construction, to allow for HVAC installations.
- B. Coordinate installation of required supporting devices and set sleeves in poured-in-place concrete and other structural components as they are constructed.
- C. Coordinate requirements for access panels and doors for HVAC items requiring access that are concealed behind finished surfaces. Access panels and doors are specified in Division 08 Section "Access Doors and Frames."
- D. Prepare Coordination / Installation Shop drawings to a scale of 1/4"=1'-0" or larger; detailing major elements, components, and systems of mechanical equipment and materials in relationship with other systems, installations, and building components. Indicate locations where space is limited for installation and access and where sequencing and coordination of installations are of importance to the efficient flow of the Work, including (but not necessarily limited to) the following:
 - 1. Structural floor, wall and roof opening sizes and details.

2. Clearances for installing and maintaining insulation.
3. Locations of light fixtures and sprinkler heads.
4. Clearances for servicing and maintaining equipment, including tube removal, filter removal, and space for equipment disassembly required for periodic maintenance.
5. Equipment connections and support details.
6. Exterior wall and foundation penetrations.
7. Routing of sanitary sewer piping.
8. Fire-rated wall and floor penetrations.
9. Sizes and location of required concrete pads and bases.
10. Valve stem movement.

PART 2 - PRODUCTS

2.01 SCOPE OF SERVICES

- A. Base bid includes Mechanical (HVAC), and Plumbing work as shown and described in the contract documents. Work will have to be done in a staged manner to allow continuous use of the balance of the facility by the building occupants. Refer to architectural staging criteria.
- B. This Division requires the furnishing and installing of all items Specified herein, indicated on the Drawings or reasonably inferred as necessary for safe and proper operation; including every article, device or accessory (whether or not specifically called for by item) reasonably necessary to facilitate each system's functioning as indicated by the design and the equipment specified. Elements of the work include, but are not limited to, materials, labor, supervision, transportation, storage, equipment, utilities, all required permits, licenses and inspections. All work performed under this Section shall be in accordance with the Project Manual, Drawings and Specifications and is subject to the terms and conditions of the Contract.
- C. The approximate locations of Mechanical (HVAC) and Plumbing items are indicated on the Drawings. These Drawings are not intended to give complete and accurate details in regard to location of outlets, apparatus, etc. Exact locations are to be determined by actual measurements at the building, and will in all cases be subject to the Review of the Owner or Engineer, who reserves the right to make any reasonable changes in the locations indicated without additional cost to the Owner.
- D. Items specifically mentioned in the Specifications but not shown on the Drawings and/or items shown on Drawings but not specifically mentioned in the Specifications shall be installed by the Contractor under the appropriate section of work as if they were both specified and shown.
- E. All discrepancies between the Contract Documents and actual job-site conditions shall be reported to the Project Manager or Engineer so that they will be resolved prior to the bidding, where this cannot be done at least 7 working days prior to bid; the greater or more costly of the discrepancy shall be bid. All labor and materials required to perform the work described shall be included as part of this Contract.
- F. It is the intention of this Section of the Specifications to outline minimum requirements to furnish the Owner with a turn-key and fully operating system in cooperation with other trades.

2.02 APPLICABLE CODES

- A. Obtain all required permits and inspections for all work required by the Contract Documents and pay all required fees in connection thereof.

- B. Arrange with the serving utility companies for the connection of all required utilities and pay all charges, meter charges, connection fees and inspection fees, if required.
- C. Comply with all applicable codes, specifications, local ordinances, industry standards, utility company regulations and the applicable requirements of the following nationally accepted codes and standards:
 - 1. Underwriters' Laboratories, Inc., UL.
 - 2. Air Moving & Conditioning Association, AMCA.
 - 3. American Standards Association, ASA.
 - 4. American Society of Heating, Refrigerating, and Air-Conditioning Engineers, Inc., ASHRAE.
 - 5. American Society of Mechanical Engineers, ASME.
 - 6. American Society of Plumbing Engineers, ASPE.
 - 7. American Society of Testing Materials, ASTM.
 - 8. American Water Works Association, AWWA.
 - 9. National Bureau of Standards, NBS.
 - 10. National Fire Protection Association, NFPA.
 - 11. Sheet Metal & Air Conditioning Contractors' National Association, SMACNA.
- D. Where differences existing between the Contract Documents and applicable state or city building codes, state and local ordinances, industry standards, utility company regulations and the applicable requirements of the above listed nationally accepted codes and standards, the more stringent or costly application shall govern. Promptly notify the Engineer in writing of all differences.
- E. When directed in writing by the Engineer, remove all work installed that does not comply with the Contract Documents and applicable state or city building codes, state and local ordinances, industry standards, utility company regulations and the applicable requirements of the above listed nationally accepted codes and standards, correct the deficiencies, and complete the work at no additional cost to the Owner.

2.03 DRAWINGS & SPECIFICATIONS

- A. These Specifications are intended to supplement the Drawings and it will not be the province of the Specifications to mention any part of the work which the Drawings are competent to fully explain in every particular and such omission is not to relieve the Contractor from carrying out portions indicated on the Drawings only.
- B. Should items be required by these Specifications and not indicated on the Drawings, they are to be supplied even if of such nature that they could have been indicated thereon. In case of disagreement between Drawings and Specifications, or within either Drawings or Specifications, the better quality or greater quantity of work shall be estimated and the matter referred to the Architect or Engineer for review with a request for information and clarification at least 7 working days prior to bid opening date for issuance of an addendum.
- C. The listing of product manufacturers, materials and methods in the various sections of the Specifications, and indicated on the Drawings, is intended to establish a standard of quality only. It is not the intention of the Owner or Engineer to discriminate against any product, material or method that is equal to the standards as indicated and/or specified, nor is it intended to preclude open, competitive bidding. The fact that a specific manufacturer is listed as an acceptable manufacturer should not be interpreted to mean that the manufacturers' standard

product will meet the requirements of the project design, Drawings, Specifications and space constraints.

- D. The Architect or Engineer and Owner shall be the sole judge of quality and equivalence of equipment, materials and methods.
- E. Products by other reliable manufacturers, other materials, and other methods, will be accepted as outlined, provided they have equal capacity, construction, and performance. However, under no circumstances shall any substitution be made without the written permission of the Architect or Engineer and Owner. Request for prior approval must be made in writing 10 days prior to the bid date without fail.
- F. Wherever a definite product, material or method is specified and there is not a statement that another product, material or method will be acceptable, it is the intention of the Owner or Engineer that the specified product, material or method is the only one that shall be used without prior approval.
- G. Wherever a definite material or manufacturer's product is specified and the Specification states that products of similar design and equal construction from the specified list of manufacturers may be substituted, it is the intention of the Owner or Engineer that products of manufacturers that are specified are the only products that will be acceptable and that products of other manufacturers will not be considered for substitution without approval.
- H. Wherever a definite product, material or method is specified and there is a statement that "OR EQUAL" product, material or method will be acceptable, it is the intention of the Owner or Engineer that the specified product, material or method or an "OR EQUAL" product, material or method may be used if it complies with the specifications and is submitted for review to the Engineer as outlined herein. Where permission to use substituted or alternative equipment on the project is granted by the Owner or Engineer in writing, it shall be the responsibility of the Contractor or Subcontractor involved to verify that the equipment will fit in the space available which includes allowances for all required Code and maintenance clearances, and to coordinate all equipment structural support, plumbing and electrical requirements and provisions with the Mechanical (HVAC) and Plumbing Design Documents and all other trades.
- I. Coordinate with Division 1 requirements for substitution, unless noted otherwise the Contractors wishing to substitute products, materials or methods from those indicated or specified, shall submit such requests to the Owner or Engineer in writing and within THIRTY (30) WORKING DAYS OF NOTIFICATION OF CONTRACT AWARD. Requests for permission to utilize alternates or substitutions will not be considered after that time, unless the Specified item is unavailable or will adversely effect to completion of the Project. Claims submitted for consideration will require notarized letters from all parties involved and will be considered only if the Contractor has been timely in his delivery for review of all required equipment and material submittals. Owner or Engineer will investigate such requests for substitution and if acceptable will issue a letter allowing the substitution.
- J. If any request for a substitution of product, material or method is rejected, the Contractor will automatically be required to furnish the product, material or method named in the Specifications. Repetitive requests for substitutions will not be considered.
- K. Timeliness: The burden of timeliness in the complete cycle of submittal data, shop Drawings, and sample processing is on the Contractor. The Contractor shall allow a minimum of six (6) weeks' time frame for review of each submission by the office of the design discipline involved after receipt of such submissions by that design discipline. The Contractor is responsible for allowing sufficient time in the construction schedule to cover the aforementioned cycles of data processing, including time for all resubmittal cycles on unacceptable materials, equipment, etc.

covered by the data submitted. Construction delays and/or lack of timeliness in the above regard are the responsibility of the Contractor and will not be considered in any request for scheduled construction time extensions and/or additional costs to the Owner.

- L. Acceptance of materials and equipment will be based on manufacturer's published data and will be tentative subject to the submission of complete shop Drawings indicating compliance with the contract documents and that adequate and acceptable clearances for entry, servicing, and maintenance will exist. Acceptance of materials and equipment under this provision shall not be construed as authorizing any deviations from the Specifications, unless the attention of the Architect/Engineer has been directed in writing to the specific deviations. Data submitted shall not contain unrelated information unless all pertinent information is properly identified.
- M. Physical Size of Equipment: Space is critical; therefore, equipment of larger sizes than shown, even though of specified manufacturer, will not be acceptable unless it can be demonstrated that ample space exists for proper installation, operation, and maintenance.
- N. Requests shall be bound and shall consist of three (3) sets of descriptive literature and performance data covering each item of equipment or material. The submittal shall include the following:
 - 1. Name of the individuals or company originating the submittal.
 - 2. Name of the project for which the submittal is made.
 - 3. An index page of the items submitted.
 - 4. A written list of variations between the specified product and the submitted product.
 - 5. Sufficient information, including scaled drawing of area and equipment involved at a scale of 1/4" = 1'-0" minimum, as required to demonstrate that the alternate or substituted product will fit in the space available.
 - 6. Identification of each item of material or equipment matching that indicated on the Drawings. All applicable industry or national Listings, Labels, Approvals and Standards shall be clearly indicated.
 - 7. Sufficient pictorial, descriptive and diagrammatic data on each item to show its conformance with the Drawings and Specifications. Any options or special requirements shall be so indicated. All non-applicable information shall be crossed out.
 - 8. Provide upon request of the Owner or Engineer, samples of materials and/or equipment as may be required.
- O. The Owner or Engineer will investigate all requests for substitutions when submitted in accordance with above and if accepted, will issue a letter allowing the substitutions. The Engineer shall be the sole authority to approve or disapprove any and all substitutions.
- P. Where equipment other than that used in the design as specified or shown on the Drawings is substituted (either from an approved manufacturers list or by submittal review), it shall be the responsibility of the substituting Contractor to coordinate space requirements, building provisions and connection requirements with his trades and all other trades and pay all additional costs to other trades, the Owner, the Architect or Engineer, if any, due to the substitutions.

2.04 RECORD DOCUMENTS

- A. Prepare record documents in accordance with the requirements in Special Project Requirements, in addition to the requirements specified in Division 23, indicate the following installed conditions.

1. Duct mains and branches, size and location, for both exterior and interior; locations of dampers, fire dampers, duct access panels, and other control devices; filters, fuel fired heaters, fan coils, condensing units, and roof-top A/C units requiring periodic maintenance or repair.
 2. Mains and branches of piping systems, with valves and control devices located and numbered, concealed unions located, and with items requiring maintenance located (i.e., traps, strainers, expansion compensators, tanks, etc.). Valve location diagrams, complete with valve tag chart. Indicate actual inverts and horizontal locations of underground piping.
 3. Equipment locations (exposed and concealed), dimensioned from prominent building lines.
 4. Approved substitutions, Contract Modifications, and actual equipment and materials installed.
 5. Contract Modifications, actual equipment and materials installed.
- B. The Contractor shall maintain a set of clearly marked black line record "AS-BUILT" prints on the job site on which he shall mark all work details, alterations to meet site conditions and changes made by "Change Order" notices. These shall be kept available for inspection by the Owner, Architect or Engineer at all times.
- C. Refer to Division 1 for additional requirements concerning record drawings. If the Contractor does not keep an accurate set of as-built drawings, the pay request may be altered or delayed at the request of the Architect. Mark the drawings with a colored pencil. Delivery of as-built prints and re-producible is a condition of final acceptance.
- D. The record prints shall be updated on a daily basis and shall indicate accurate dimensions for all buried or concealed work, precise locations of all concealed pipe or duct, locations of all concealed valves, controls and devices and any deviations from the work shown on the Construction Documents which are required for coordination. All dimensions shall include at least two dimensions to permanent structure points.
- E. At the Engineer's option, the Contractor shall transfer all data from the record "AS-BUILT" prints to an electronic media such as AutoCAD latest release, in order to plot the reproducible media "AS-BUILT" drawings. Since data stored on electronic media can deteriorate undetected or be modified without the Engineer's knowledge, the AutoCAD electronic drawing files are provided without warranty or obligation on the part of the Engineer as to accuracy or information contained in the files. All information in the files shall be independently verified by the user. Any user shall agree to indemnify and hold the Engineer harmless from any and all claims, damages, losses, and expenses including but not limited to Attorney's fees arising out of the use of the AutoCAD drawing files. Engineer shall furnish to the Contractor electronic media files of Contract Documents for the Contractor to use for inputting of the data from the record "AS-BUILT" prints and the Contractor shall return the revised electronic files on CD ROM properly labeled to the Engineer and shall submit the plotted reproducible drawings and three (3) sets of black line prints to the Architect or Engineer for review prior to scheduling the final inspection at the completion of the work. The reproducible record "AS-BUILT" drawings shall have the Engineers Name and Seal removed or blanked out and shall be clearly marked and signed on each sheet as described in paragraph F. below.
- F. of the work, the Contractor shall transfer all marks from the submit a set of clear concise set of reproducible record "AS-BUILT" drawings and shall submit the reproducible drawings with corrections made by a competent draftsman and three (3) sets of black line prints to the Architect or Engineer for review prior to scheduling the final inspection at the completion of

the work. The reproducible record "AS-BUILT" drawings shall have the Engineers Name and Seal removed or blanked out and shall be clearly marked and signed on each sheet.

- G. No retainage shall be released until LSCS has received all Operations and Maintenance manuals, keys, record drawings, and warranty certificates.

2.05 OPERATION AND MAINTENANCE MANUALS

- A. In addition to the above, the Contractor shall accumulate during the progress of the job the following data, in duplicate, prepared in a neat brochure or packet folder and turn over to the Architect/Engineer for review, and subsequent delivery to the Owner.
 - 1. All warranties and guarantees and manufacturers' directions on equipment and material covered by the Contract.
 - 2. Two sets of operating instructions for heating and cooling and other mechanical and electrical systems. Operating instructions shall also include recommended preventative maintenance and seasonal changeover procedures.
 - 3. Valve tag charts and diagrams specified herein.
 - 4. Approved wiring diagrams and control diagrams representing "as installed" conditions.
 - 5. Copies of approved Shop Drawings.
 - 6. Any and all other data and/or drawings required as submittals during construction.
 - 7. Repair parts list of all major items and equipment.
 - 8. As-built record drawings.
- B. O & M manuals shall also provide the following information.
 - 1. All equipment sizes and selected options.
 - 2. Operation instructions for each piece of equipment requiring maintenance with actions clearly identified.
 - 3. Name, address, telephone numbers and e-mail address of local supplier or agent.
 - 4. Web site address of each manufacturer.
 - 5. HVAC controls system maintenance information.
 - 6. A complete narrative on how each system is intended to operate.

2.06 PIPE, TUBE, AND FITTINGS

- A. Refer to individual Division 23 piping Sections for pipe, tube, and fitting materials and joining methods.
- B. Pipe Threads: ASME B1.20.1 for factory-threaded pipe and pipe fittings.

2.07 JOINING MATERIALS

- A. Refer to individual Division 23 piping Sections for special joining materials not listed below.
- B. Pipe-Flange Gasket Materials: Suitable for chemical and thermal conditions of piping system contents.
 - 1. ASME B16.21, nonmetallic, flat, asbestos-free, 1/8-inch maximum thickness unless thickness or specific material is indicated.
 - a. Full-Face Type: For flat-face, Class 125, cast-iron and cast-bronze flanges.
 - b. Narrow-Face Type: For raised-face, Class 250, cast-iron and steel flanges.
 - 2. AWWA C110, rubber, flat face, 1/8 inch thick, unless otherwise indicated; and full-face or ring type, unless otherwise indicated.

- C. Flange Bolts and Nuts: ASME B18.2.1, carbon steel, unless otherwise indicated.
- D. Plastic, Pipe-Flange Gasket, Bolts, and Nuts: Type and material recommended by piping system manufacturer, unless otherwise indicated.
- E. Solder Filler Metals: ASTM B 32, lead-free alloys. Include water-flushable flux according to ASTM B 813.
- F. Brazing Filler Metals: AWS A5.8, BCuP Series, copper-phosphorus alloys for general-duty brazing, unless otherwise indicated; and AWS A5.8, BAg1, silver alloy for refrigerant piping, unless otherwise indicated.
- G. Welding Filler Metals: Comply with AWS D10.12 for welding materials appropriate for wall thickness and chemical analysis of steel pipe being welded.
- H. Solvent Cements for Joining Plastic Piping:
 - 1. CPVC Piping: ASTM F 493.
 - 2. PVC Piping: ASTM D 2564. Include primer according to ASTM F 656.
- I. Fiberglass Pipe Adhesive: As furnished or recommended by pipe manufacturer.

2.08 TRANSITION FITTINGS

- A. Plastic-to-Metal Transition Fittings: PVC one-piece fitting with manufacturer's Schedule 80 equivalent dimensions; one end with threaded brass insert, and one solvent-cement-joint end.
 - 1. Manufacturers:
 - a. Eslon Thermoplastics.
- B. Plastic-to-Metal Transition Adaptors: One-piece fitting with manufacturer's SDR 11 equivalent dimensions; one end with threaded brass insert, and one solvent-cement-joint end.
 - 1. Manufacturers:
 - 2. Thompson Plastics, Inc.
- C. Plastic-to-Metal Transition Unions: MSS SP-107, PVC four-part union. Include brass end, solvent-cement-joint end, rubber O-ring, and union nut.
 - 1. Manufacturers:
 - a. NIBCO INC.
 - b. NIBCO, Inc.; Chemtrol Div.

2.09 DIELECTRIC FITTINGS

- A. Description: Combination fitting of copper alloy and ferrous materials with threaded, solder-joint, plain, or weld-neck end connections that match piping system materials.
- B. Insulating Material: Suitable for system fluid, pressure, and temperature.
- C. Dielectric Unions: Factory-fabricated, union assembly, for 250-psig minimum working pressure at 180 deg F.
 - 1. Manufacturers:
 - a. Capitol Manufacturing Co.
 - b. Central Plastics Company.
 - c. Eclipse, Inc.
 - d. EpcO Sales, Inc.
 - e. Hart Industries, International, Inc.

- f. Watts Industries, Inc.; Water Products Div.
 - g. Zurn Industries, Inc.; Wilkins Div.
- D. Dielectric Flanges: Factory-fabricated, companion-flange assembly, for 150- or 300-psig minimum working pressure as required to suit system pressures.
 - 1. Manufacturers:
 - a. Capitol Manufacturing Co.
 - b. Central Plastics Company.
 - c. Epcos Sales, Inc.
 - d. Watts Industries, Inc.; Water Products Div.
- E. Dielectric-Flange Kits: Companion-flange assembly for field assembly. Include flanges, full-face- or ring-type neoprene or phenolic gasket, phenolic or polyethylene bolt sleeves, phenolic washers, and steel backing washers.
 - 1. Manufacturers:
 - a. Advance Products & Systems, Inc.
 - b. Calpico, Inc.
 - c. Central Plastics Company.
 - d. Pipeline Seal and Insulator, Inc.
 - 2. Separate companion flanges and steel bolts and nuts shall have 150- or 300-psig minimum working pressure where required to suit system pressures.
- F. Dielectric Couplings: Galvanized-steel coupling with inert and noncorrosive, thermoplastic lining; threaded ends; and 300-psig minimum working pressure at 225 deg F.
 - 1. Manufacturers:
 - a. Calpico, Inc.
 - b. Lochinvar Corp.
- G. Dielectric Nipples: Electroplated steel nipple with inert and noncorrosive, thermoplastic lining; plain, threaded, or grooved ends; and 300-psig minimum working pressure at 225 deg F.
 - 1. Manufacturers:
 - a. Perfection Corp.
 - b. Precision Plumbing Products, Inc.
 - c. Sioux Chief Manufacturing Co., Inc.
 - d. Victaulic Co. of America.

2.10 MECHANICAL SLEEVE SEALS

- A. Description: Modular sealing element unit, designed for field assembly, to fill annular space between pipe and sleeve.
 - 1. Manufacturers:
 - a. Advance Products & Systems, Inc.
 - b. Calpico, Inc.
 - c. Metraflex Co.
 - d. Pipeline Seal and Insulator, Inc.
 - 2. Sealing Elements: EPDM interlocking links shaped to fit surface of pipe. Include type and number required for pipe material and size of pipe.

3. Pressure Plates: Plastic Carbon steel Stainless steel. Include two for each sealing element.
4. Connecting Bolts and Nuts: Carbon steel with corrosion-resistant coating of length required to secure pressure plates to sealing elements. Include one for each sealing element.

2.11 SLEEVES

- A. Galvanized-Steel Sheet: 0.0239-inch minimum thickness; round tube closed with welded longitudinal joint.
- B. Steel Pipe: ASTM A 53, Type E, Grade B, Schedule 40, galvanized, plain ends.
- C. Cast Iron: Cast or fabricated "wall pipe" equivalent to ductile-iron pressure pipe, with plain ends and integral waterstop, unless otherwise indicated.
- D. Stack Sleeve Fittings: Manufactured, cast-iron sleeve with integral clamping flange. Include clamping ring and bolts and nuts for membrane flashing.
 1. Underdeck Clamp: Clamping ring with set screws.
- E. Molded PVC: Permanent, with nailing flange for attaching to wooden forms.
- F. PVC Pipe: ASTM D 1785, Schedule 40.
- G. Molded PE: Reusable, PE, tapered-cup shaped, and smooth-outer surface with nailing flange for attaching to wooden forms.

2.12 ESCUTCHEONS

- A. Description: Manufactured wall and ceiling escutcheons and floor plates, with an ID to closely fit around pipe, tube, and insulation of insulated piping and an OD that completely covers opening.
- B. One-Piece, Deep-Pattern Type: Deep-drawn, box-shaped brass with polished chrome-plated finish.
- C. One-Piece, Cast-Brass Type: With set screw.
 1. Finish: Polished chrome-plated.
- D. Split-Casting, Cast-Brass Type: With concealed hinge and set screw.
 1. Finish: Polished chrome-plated.
- E. One-Piece, Stamped-Steel Type: With set screw and chrome-plated finish.
- F. Split-Plate, Stamped-Steel Type: With concealed set screw or spring clips, and chrome-plated finish.
- G. One-Piece, Floor-Plate Type: Cast-iron floor plate.
- H. Split-Casting, Floor-Plate Type: Cast brass with concealed hinge and set screw.

2.13 GROUT & FOUNDATION

- A. Description: ASTM C 1107, Grade B, nonshrink and nonmetallic, dry hydraulic-cement grout.
 1. Characteristics: Post-hardening, volume-adjusting, nonstaining, noncorrosive, nongaseous, and recommended for interior and exterior applications.
 2. Design Mix: 5000-psi, 28-day compressive strength.
 3. Packaging: Premixed and factory packaged.
- B. Foundations and pads shall be constructed of reinforced concrete and shall be sized and reinforced as noted or detailed on the Drawings. As a minimum, pads shall be 6" thick, by

width and length as required by item it is under, reinforced with 6 x 6 W2.9 x W2.9 Welded Wire mesh.

- C. Support attachments, unless otherwise noted on shown, shall be securely attached to the items foundation, pad or building structure, per manufacturers recommendations and shall be approved by the Architect.

PART 3 - EXECUTION

3.01 HVAC DEMOLITION

- A. Refer to Division 01 Section "Cutting and Patching" and Division 02 Section "Selective Structure Demolition" for general demolition requirements and procedures.
- B. Disconnect, demolish, and remove HVAC systems, equipment, and components indicated to be removed.
 - 1. Piping to Be Removed: Remove portion of piping indicated to be removed and cap or plug remaining piping with same or compatible piping material.
 - 2. Piping to Be Abandoned in Place: Drain piping and cap or plug piping with same or compatible piping material.
 - 3. Ducts to Be Removed: Remove portion of ducts indicated to be removed and plug remaining ducts with same or compatible ductwork material.
 - 4. Ducts to Be Abandoned in Place: Cap or plug ducts with same or compatible ductwork material.
 - 5. Equipment to Be Removed: Disconnect and cap services and remove equipment.
 - 6. Equipment to Be Removed and Reinstalled: Disconnect and cap services and remove, clean, and store equipment; when appropriate, reinstall, reconnect, and make equipment operational.
 - 7. Equipment to Be Removed and Salvaged: Disconnect and cap services and remove equipment and deliver to Owner.
- C. If pipe, insulation, or equipment to remain is damaged in appearance or is unserviceable, remove damaged or unserviceable portions and replace with new products of equal capacity and quality.

3.02 PIPING SYSTEMS - COMMON REQUIREMENTS

- A. Install piping according to the following requirements and Division 23 Sections specifying piping systems.
- B. Drawing plans, schematics, and diagrams indicate general location and arrangement of piping systems. Indicated locations and arrangements were used to size pipe and calculate friction loss, expansion, pump sizing, and other design considerations. Install piping as indicated unless deviations to layout are approved on Coordination Drawings.
- C. Install piping in concealed locations, unless otherwise indicated and except in equipment rooms and service areas.
- D. Install piping indicated to be exposed and piping in equipment rooms and service areas at right angles or parallel to building walls. Diagonal runs are prohibited unless specifically indicated otherwise.
- E. Install piping above accessible ceilings to allow sufficient space for ceiling panel removal.
- F. Install piping to permit valve servicing.

- G. Install piping at indicated slopes.
- H. Install piping free of sags and bends.
- I. Install fittings for changes in direction and branch connections.
- J. Install piping to allow application of insulation.
- K. Select system components with pressure rating equal to or greater than system operating pressure.
- L. Install escutcheons for penetrations of walls, ceilings, and floors according to the following:
 - 1. New Piping:
 - a. Piping with Fitting or Sleeve Protruding from Wall: One-piece, deep-pattern type.
 - b. Chrome-Plated Piping: One-piece, cast-brass type with polished chrome-plated finish.
 - c. Insulated Piping: One-piece, stamped-steel type with spring clips.
 - d. Bare Piping at Wall and Floor Penetrations in Finished Spaces: One-piece, cast-brass type with polished chrome-plated finish.
 - e. Bare Piping at Wall and Floor Penetrations in Finished Spaces: One-piece, stamped-steel type.
 - f. Bare Piping at Ceiling Penetrations in Finished Spaces: One-piece or split-casting, cast-brass type with polished chrome-plated finish.
 - g. Bare Piping at Ceiling Penetrations in Finished Spaces: Split-plate, stamped-steel type with concealed hinge and set screw.
 - h. Bare Piping in Unfinished Service Spaces: One-piece, cast-brass type with polished chrome-plated finish.
 - i. Bare Piping in Unfinished Service Spaces: One-piece, stamped-steel type with concealed or exposed-rivet hinge and set screw or spring clips.
 - j. Bare Piping in Equipment Rooms: One-piece, cast-brass type.
 - k. Bare Piping in Equipment Rooms: One-piece, stamped-steel type with set screw.
 - l. Bare Piping at Floor Penetrations in Equipment Rooms: One-piece, floor-plate type.
 - 2. Existing Piping: Use the following:
 - a. Chrome-Plated Piping: Split-casting, cast-brass type with chrome-plated finish.
 - b. Insulated Piping: Split-plate, stamped-steel type with concealed or exposed-rivet hinge and spring clips.
 - c. Bare Piping at Wall and Floor Penetrations in Finished Spaces: Split-casting, cast-brass type with chrome-plated finish.
 - d. Bare Piping at Wall and Floor Penetrations in Finished Spaces: Split-plate, stamped-steel type with concealed hinge and spring clips.
 - e. Bare Piping at Ceiling Penetrations in Finished Spaces: Split-casting, cast-brass type with chrome-plated finish.
 - f. Bare Piping at Ceiling Penetrations in Finished Spaces: Split-plate, stamped-steel type with concealed hinge and set screw.
 - g. Bare Piping in Unfinished Service Spaces: Split-casting, cast-brass type with polished chrome-plated finish.
 - h. Bare Piping in Unfinished Service Spaces: Split-plate, stamped-steel type with concealed or exposed-rivet hinge and set screw or spring clips.
 - i. Bare Piping in Equipment Rooms: Split-casting, cast-brass type.

- j. Bare Piping in Equipment Rooms: Split-plate, stamped-steel type with set screw or spring clips.
 - k. Bare Piping at Floor Penetrations in Equipment Rooms: Split-casting, floor-plate type.
- M. Sleeves are not required for core-drilled holes.
- N. Permanent sleeves are not required for holes formed by removable PE sleeves.
- O. Install sleeves for pipes passing through concrete and masonry walls and concrete floor and roof slabs.
- P. Install sleeves for pipes passing through concrete and masonry walls, gypsum-board partitions, and concrete floor and roof slabs.
 - 1. Cut sleeves to length for mounting flush with both surfaces.
 - a. Exception: Extend sleeves installed in floors of mechanical equipment areas or other wet areas 2 inches above finished floor level. Extend cast-iron sleeve fittings below floor slab as required to secure clamping ring if ring is specified.
 - 2. Install sleeves in new walls and slabs as new walls and slabs are constructed.
 - 3. Install sleeves that are large enough to provide 1/4-inch annular clear space between sleeve and pipe or pipe insulation. Use the following sleeve materials:
 - a. Steel Pipe Sleeves: For pipes smaller than NPS 6.
 - b. Steel Sheet Sleeves: For pipes NPS 6 and larger, penetrating gypsum-board partitions.
 - c. Stack Sleeve Fittings: For pipes penetrating floors with membrane waterproofing. Secure flashing between clamping flanges. Install section of cast-iron soil pipe to extend sleeve to 2 inches above finished floor level. Refer to Division 07 Section "Sheet Metal Flashing and Trim" for flashing.
 - (1) Seal space outside of sleeve fittings with grout.
 - d. Except for underground wall penetrations, seal annular space between sleeve and pipe or pipe insulation, using joint sealants appropriate for size, depth, and location of joint. Refer to Division 07 Section "Joint Sealants" for materials and installation.
- Q. Aboveground, Exterior-Wall Pipe Penetrations: Seal penetrations using sleeves and mechanical sleeve seals. Select sleeve size to allow for 1-inch annular clear space between pipe and sleeve for installing mechanical sleeve seals.
 - 1. Install steel pipe for sleeves smaller than 6 inches in diameter.
 - 2. Install cast-iron "wall pipes" for sleeves 6 inches and larger in diameter.
 - 3. Mechanical Sleeve Seal Installation: Select type and number of sealing elements required for pipe material and size. Position pipe in center of sleeve. Assemble mechanical sleeve seals and install in annular space between pipe and sleeve. Tighten bolts against pressure plates that cause sealing elements to expand and make watertight seal.
- R. Underground, Exterior-Wall Pipe Penetrations: Install cast-iron "wall pipes" for sleeves. Seal pipe penetrations using mechanical sleeve seals. Select sleeve size to allow for 1-inch annular clear space between pipe and sleeve for installing mechanical sleeve seals.
 - 1. Mechanical Sleeve Seal Installation: Select type and number of sealing elements required for pipe material and size. Position pipe in center of sleeve. Assemble mechanical sleeve seals and install in annular space between pipe and sleeve. Tighten bolts against pressure plates that cause sealing elements to expand and make watertight seal.

- S. Fire-Barrier Penetrations: Maintain indicated fire rating of walls, partitions, ceilings, and floors at pipe penetrations. Seal pipe penetrations with firestop materials. Refer to Division 07 Section "Penetration Firestopping" for materials.
- T. Verify final equipment locations for roughing-in.
- U. Refer to equipment specifications in other Sections of these Specifications for roughing-in requirements.

3.03 PIPING JOINT CONSTRUCTION

- A. Join pipe and fittings according to the following requirements and Division 23 Sections specifying piping systems.
- B. Ream ends of pipes and tubes and remove burrs. Bevel plain ends of steel pipe.
- C. Remove scale, slag, dirt, and debris from inside and outside of pipe and fittings before assembly.
- D. Soldered Joints: Apply ASTM B 813, water-flushable flux, unless otherwise indicated, to tube end. Construct joints according to ASTM B 828 or CDA's "Copper Tube Handbook," using lead-free solder alloy complying with ASTM B 32.
- E. Brazed Joints: Construct joints according to AWS's "Brazing Handbook," "Pipe and Tube" Chapter, using copper-phosphorus brazing filler metal complying with AWS A5.8.
- F. Threaded Joints: Thread pipe with tapered pipe threads according to ASME B1.20.1. Cut threads full and clean using sharp dies. Ream threaded pipe ends to remove burrs and restore full ID. Join pipe fittings and valves as follows:
 - 1. Apply appropriate tape or thread compound to external pipe threads unless dry seal threading is specified.
 - 2. Damaged Threads: Do not use pipe or pipe fittings with threads that are corroded or damaged. Do not use pipe sections that have cracked or open welds.
- G. Welded Joints: Construct joints according to AWS D10.12, using qualified processes and welding operators according to Part 1 "Quality Assurance" Article.
- H. Flanged Joints: Select appropriate gasket material, size, type, and thickness for service application. Install gasket concentrically positioned. Use suitable lubricants on bolt threads.
- I. Plastic Piping Solvent-Cement Joints: Clean and dry joining surfaces. Join pipe and fittings according to the following:
 - 1. Comply with ASTM F 402 for safe-handling practice of cleaners, primers, and solvent cements.
 - 2. CPVC Piping: Join according to ASTM D 2846/D 2846M Appendix.
 - 3. PVC Pressure Piping: Join schedule number ASTM D 1785, PVC pipe and PVC socket fittings according to ASTM D 2672. Join other-than-schedule-number PVC pipe and socket fittings according to ASTM D 2855.
 - 4. PVC Nonpressure Piping: Join according to ASTM D 2855.
- J. Plastic Pressure Piping Gasketed Joints: Join according to ASTM D 3139.
- K. Plastic Nonpressure Piping Gasketed Joints: Join according to ASTM D 3212.
- L. PE Piping Heat-Fusion Joints: Clean and dry joining surfaces by wiping with clean cloth or paper towels. Join according to ASTM D 2657.
 - 1. Plain-End Pipe and Fittings: Use butt fusion.

2. Plain-End Pipe and Socket Fittings: Use socket fusion.
- M. Fiberglass Bonded Joints: Prepare pipe ends and fittings, apply adhesive, and join according to pipe manufacturer's written instructions.

3.04 PIPING CONNECTIONS

- A. Make connections according to the following, unless otherwise indicated:
 1. Install unions, in piping NPS 2 and smaller, adjacent to each valve and at final connection to each piece of equipment.
 2. Install flanges, in piping NPS 2-1/2 and larger, adjacent to flanged valves and at final connection to each piece of equipment.
 3. Dry Piping Systems: Install dielectric unions and flanges to connect piping materials of dissimilar metals.
 4. Wet Piping Systems: Install dielectric coupling and nipple fittings to connect piping materials of dissimilar metals.

3.05 INSTALLATION METHODS

- A. Where to Conceal: All pipes, conduits, etc., shall be concealed in pipe chases, walls, furred spaces, or above the ceilings of the building unless otherwise indicated.
- B. Where to Expose: In mechanical rooms, janitor's closets tight against pan soffits in exposed "Tee" structures, or storage spaces, but only where necessary, piping may be run exposed. All exposed piping shall be run in the most aesthetic, inconspicuous manner, and parallel or perpendicular to the building lines.
- C. Support: All piping, ducts and conduits shall be adequately and properly supported from the building structure by means of hanger rods or clamps to walls as herein specified.
- D. Maintaining Clearance: Where limited space is available above the ceilings below concrete beams or other deep projections, pipe and conduit shall be sleeved through the projection where it crosses, rather than hung below them in a manner to provide maximum above-floor clearance. Sleeves shall be as herein specified. Approval shall be obtained from the Architect/Engineer for each penetration.
- E. All pipe, conduits, etc., shall be cut accurately to measurements established at the building and shall be worked into place without springing or forcing. All ducts, pipes and conduits run exposed in machinery and equipment rooms shall be installed parallel to the building lines, except that piping shall be sloped to obtain the proper pitch. Piping, ducts and conduits run in furred ceilings, etc., shall be similarly installed, except as otherwise shown. Conduits in furred ceilings and in other concealed spaces shall be neatly grouped and racked indicating good workmanship. All conduit and pipe openings shall be kept closed until the systems are closed with final connections.

3.06 EQUIPMENT INSTALLATION - COMMON REQUIREMENTS

- A. Install equipment to allow maximum possible headroom unless specific mounting heights are not indicated.
- B. Install equipment level and plumb, parallel and perpendicular to other building systems and components in exposed interior spaces, unless otherwise indicated.
- C. Install HVAC equipment to facilitate service, maintenance, and repair or replacement of components. Connect equipment for ease of disconnecting, with minimum interference to other installations. Extend grease fittings to accessible locations.

- D. Install equipment to allow right of way for piping installed at required slope.

3.07 CONNECTIONS FOR OTHERS

- A. The Mechanical Contractor shall rough in for and make all gas, water, steam, sewer, etc. connections to all fixtures, equipment, machinery, etc., provided by others in accordance with detailed roughing-in Drawings provided by the equipment suppliers, by actual measurements of the equipment connections, or as detailed.
- B. After the equipment is set in place, this Contractor shall make all final connections and shall provide all required pipe, fittings, valves, traps, etc.
- C. Provide all air gap fittings required, using materials hereinbefore specified. In each service line connected to an item of equipment or piece of machinery, provide a shutoff valve. On each drain not provided with a trap, provide a suitable trap.
- D. All pipe fittings, valves, traps, etc., exposed in finished areas and connected to chrome plated lines provided by others shall be chrome plated to match.
- E. Provide all sheet metal ductwork, transition pieces, etc., required for a complete installation of vent hoods, fume hoods, etc., provided by others.

3.08 CUTTING AND PATCHING

- A. General: Cut and patch walls, floors, etc., resulting from work in existing construction or by failure to provide proper openings or recesses in new construction.
- B. Methods of cutting: Openings cut through concrete and masonry shall be made with masonry saws and/or core drills and at such locations acceptable to the Architect/Engineer. Impact-type equipment shall not be used except where specifically acceptable to the Architect/Engineer. Openings in precast concrete slabs for pipes, conduits, outlet boxes, etc., shall be core drilled to exact size.
- C. Restoration: All openings shall be restored to "as-new" condition under the appropriate Specification Section for the materials involved, and shall match remaining surrounding materials and/or finishes.
- D. Masonry: Where openings are cut through masonry walls, provide and install lintels or other structural supports to protect the remaining masonry. Adequate supports shall be provided during the cutting operation to prevent any damage to the masonry occasioned by the operation. All structural members, supports, etc., shall be of the proper size and shape, and shall be installed in a manner acceptable to the Architect/Engineer.
- E. Plaster: All mechanical work in areas containing plaster shall be completed prior to the application of the finish plaster coat. Cutting of finish plaster coat will not be permitted.

3.09 ACCESS DOORS

- A. General: This Contractor shall provide wall or ceiling access doors for unrestricted access to all concealed items of mechanical equipment or devices.
- B. Doors: Access doors mounted in painted surfaces shall be of Milcor (Inland-Ryerson Construction Products Company) manufacture, Style K for plastered surfaces and Style M or DW for non-plastered surfaces. The Style K doors shall be set so that the finished surface of the door is even with the finished surface of the adjacent finishes. Access doors mounted on tile surfaces shall be of similar construction as noted above, except they shall be of stainless steel materials. Access doors shall be a minimum of 12" x 12" in size.

3.10 ROOF PENETRATIONS AND FLASHING

- A. Pipe, conduit and duct sleeves, pitch pockets, and flashings compatible with the roofing installation shall be provided and installed by a qualified contractor for all roof penetrations. This shall be the responsibility of the General Contractor.

3.11 EXCAVATION, TRENCHING AND BACKFILL

- A. The Mechanical and Electrical subcontractors shall perform all excavations of every description, for their particular installations and of whatever substances encountered, to the depths indicated on the Drawings and/or required for the installation of piping, conduit, utility systems, etc. All exterior lines shall be installed with a minimum cover of 24", unless otherwise indicated. Generally, more cover shall be provided if grade will permit. All excavation materials not required for backfill or fill shall be removed and wasted as acceptable to the Construction Inspector. All excavations shall be made only by open cut. The banks of trenches shall be kept as nearly vertical as possible and where required, shall be properly sheeted and braced. Trenches shall be not less than 12" wider nor more than 16" wider than the outside edges of the pipe to be laid therein, and shall be excavated true to line so that a clear space not less than 6" nor more than 8" in width is provided on each side of the pipe. For sewers, the maximum width of trench specified applies to the width at and below the level may be made as wide as necessary for sheeting and bracing, and the proper installation of the work.
- B. The bottom of trenches shall be accurately graded to provide proper fall and uniform bearing and support for each section of the pipe on undisturbed soil or 2" of sand fill at every point along its entire length, except for portions of the pipe sections where it is necessary to excavate for bell holes and for the proper sealing of pipe joints. Bell holes shall be dug after the trench bottom has been graded. Where inverts are not shown, grading shall be determined by the National Plumbing Code for the service intended and the size used. Bell holes for lead pipe joints shall be 12" in depth below the trench bottom and shall extend from a point 6" back of the face of the bell. Such bell holes shall be of sufficient width to provide ample room for caulking. Bell holes for sewer tile and water pipe shall be excavated only to an extent sufficient to permit accurate work in the making of the joints and to insure that the pipe, for a maximum of its length, will rest upon the prepared bottom of the trench. Depressions for joints other than bell-and-spigot shall be made in accordance with the recommendations of the joint manufacturer for the particular type of joint used. In general, grading for electrical duct banks and conduits shall be from building to manhole, and from a high point between manholes to each manhole. Special pipe beds shall be provided as specified hereinafter.
- C. The lower 4" of the pipe trenches measuring from an overhead line set parallel to the grade line of the sewer shall be excavated only a few feet in advance to the pipe laying, by men especially skilled in this type of work. Where damage is likely to result from withdrawing sheeting, the sheeting shall be left in place. Except at locations where excavation of rock from the bottom of trenches is required, care shall be taken not to excavate below the depths required. Where rock excavation is required, the rock shall be excavated to a minimum over depth of 6" below the trench depths specified. The over depth rock excavation and all excess trench excavation shall be backfilled with sand. Whenever wet or otherwise unstable soil is incapable of properly supporting the pipe is encountered in the trench bottom, such soil shall be removed to a depth and for the trench lengths required, and then backfilled to trench bottom grade, as hereinafter specified, with sand.
- D. All grading in the vicinity of excavation shall be controlled to prevent surface ground water from flowing into the excavations. Any water accumulated in the excavations shall be removed by pumping or other acceptable method. During excavation, material suitable for backfilling shall be stacked in an orderly manner a sufficient distance back from edges of trenches to avoid

overloading and prevent slides or cave-ins. Material unsuitable for backfilling shall be wasted and removed from the job site as directed by the Construction Inspector.

- E. All shoring and sheeting required to perform and protect the excavations and to safeguard employees and/or adjacent structures shall be provided.
- F. Excavate as required under the building in order that all piping, ductwork, etc., shall clear the ground a minimum of 12" for a distance of 24" on either side. Edges of such excavations shall slope at an angle of not over 45 degrees with the horizontal unless otherwise approved by the Construction Inspector. The bottom of such excavation shall be graded to drain in a manner acceptable to the Construction Inspector.
- G. Trenches for cast iron drain, storm water and sewer lines inside the building shall be properly excavated, following, in general, the procedures set out for exterior lines. Where floors are to be poured over these lines, they shall be backfilled, tamped and settled with water. Where no flooring is to cover the lines, they shall be backfilled to form a level grade.
- H. All surplus materials removed in these trenching operations becomes the property of the contractor, and shall be disposed of at the expense of the contractor, at a legal disposal site, off of the project site.
- I. Trenches shall not be backfilled until all required tests are performed and until the piping, utilities systems, etc., as installed are certified by the Owner's inspector to conform to the requirements specified hereinafter. The trenches shall be carefully backfilled with sand to a depth of 12 inches above the top of the pipe. The next layer and subsequent layers of backfill may be excavated materials approved for backfilling, consisting of earth, loam, sandy clay, sand and gravel, soft shale, or other approved materials free from large clods of earth or stones larger than 1 1/2" in diameter, flooded until the pipe has cover of not less than one foot. The remainder of the backfill material shall then be thrown into the trenches, moistened, and tamped or flooded in one foot layers. Blasted rock, broken concrete or pavement, and large boulders shall not be used as backfill material. Any trenches improperly backfilled, or where settlement occurs, shall be reopened to the depth required for proper compaction, then refilled and mounded over, and smoothed off.
- J. Backfill under concrete slabs-on-fill shall be as specified above, shall be gravel, or shall be other such materials more suitable for the application. Installation and compaction shall be as required for compatibility with adjacent materials.
- K. Opening and Re-closing Pavement and Lawns: Where excavation requires the opening of existing walks, streets, drives, other existing pavement, or lawns, such surfaces shall be cut as required to install new lines and to make new connections to existing lines. The sizes of the cut shall be held to a minimum, consistent with the work to be accomplished. After the installation of the new work is completed and the excavation has been backfilled and flooded, the area shall be patched, using materials to match those cut out. The patches shall thoroughly bond with the original surfaces and shall be level with them, and shall meet all the requirements established by the authorities having jurisdiction over such areas.

3.12 OPERATION PRIOR TO COMPLETION

- A. When any piece of mechanical equipment is operable and it is to the advantage of the Contractor to operate the equipment, he may do so, providing that he properly supervises the operation, and has the Construction Inspector's written permission to do so. The warranty period shall, however, not commence until such time as the equipment is operated for the beneficial use of the Owner, or date of substantial completion, whichever occurs first.

- B. Regardless of whether or not the equipment has or has not been operated, the Contractor shall properly clean the equipment, install clean filter media, properly adjust, and complete all deficiency list items before final acceptance by the Owner. The date of acceptance and performance certification will be the same date.

3.13 CHECKING AND TESTING MATERIALS AND/OR EQUIPMENT

- A. Before the work is accepted, an authorized representative of the manufacturer of the installed materials and/or equipment shall personally inspect the installation and operation of his materials and/or equipment to determine that it is properly installed and in proper operating order. The qualifications of the representative shall be appropriate to the technical requirements of the installation. The qualifications of the representative shall be submitted to the owner for approval. The decision of the owner concerning the appropriateness of the representative shall be final. Testing and checking shall be accomplished during the course of the work where required by work being concealed, and at the completion of the work otherwise. In addition, the Contractor shall submit to the Architect/Engineer a signed statement from each representative certifying as follows: "I certify that the materials and/or equipment listed below have been personally inspected by the undersigned authorized manufacturer's representative and is properly installed and operating in accordance with the manufacturer's recommendations".
- B. Check inspections shall include plumbing equipment, heating, air conditioning, insulation, ventilating equipment, controls, mechanical equipment and such other items hereinafter specified or specifically designated by the Architect/Engineer.
- C. The Contractor shall make, at no additional cost to the Owner, any tests deemed necessary by the inspection departments having jurisdiction, and in the National Fire Protection Association, ASTM, etc. Standards listed. The Contractor shall provide all equipment, materials, and labor for making such tests. Reasonable amounts of fuel and electrical energy costs for system tests will be paid by the Owner. Fuel and electrical energy costs for system adjustment and tests which follow beneficial occupancy by the Owner will be borne by the Owner.
- D. Additional tests specified hereinafter under the various Specification Sections shall be made.
- E. The Construction Inspector shall be notified in writing at least 10 working days prior to each test and other Specification requirements requiring action on the part of the Construction Inspector. All equipment shall be placed in operation and tested for proper automatic control requirements before the balancing agency starts their work.

3.14 PAINTING

- A. Painting of HVAC systems, equipment, and components is specified in Division 09 Sections "Interior Painting" and "Exterior Painting."
- B. All equipment, piping, conduit, ductwork, grilles, insulation, etc., furnished and installed in exposed areas under Divisions 22, 23 and 26 of these Specifications and as hereinafter specified shall be cleaned, prepared, and painted according to the following specification. In the event of a conflict between the specifications referenced, the provisions of this specification shall prevail only for Division 22, 23 and Division 26 work.
- C. All purchased equipment furnished by the mechanical and electrical subcontractors shall be delivered to the job with a suitable factory protective finish with the colors hereinafter specified. The following materials shall not be painted: copper, galvanized metal, stainless steel, fiberglass, PVC, and PVDF.

- D. Before painting, materials and equipment surfaces shall be thoroughly cleaned of cement, plaster, and other foreign materials, and all oil and grease spots shall be removed. Such surfaces shall be carefully wiped and all cracks and corners scraped out. Exposed metal work shall be carefully brushed down with the steel brushes to remove rust and other spots and left smooth and clean.
- E. Damage and Touchup: Repair marred and damaged factory-painted finishes with materials and procedures to match original factory finish.

3.15 CONCRETE BASES

- A. Concrete Bases: Anchor equipment to concrete base according to equipment manufacturer's written instructions and according to seismic codes at Project.
 - 1. Construct concrete bases of dimensions indicated, but not less than 4 inches larger in both directions than supported unit.
 - 2. Install dowel rods to connect concrete base to concrete floor. Unless otherwise indicated, install dowel rods on 18-inch centers around the full perimeter of the base.
 - 3. Install epoxy-coated anchor bolts for supported equipment that extend through concrete base, and anchor into structural concrete floor.
 - 4. Place and secure anchorage devices. Use supported equipment manufacturer's setting drawings, templates, diagrams, instructions, and directions furnished with items to be embedded.
 - 5. Install anchor bolts to elevations required for proper attachment to supported equipment.
 - 6. Install anchor bolts according to anchor-bolt manufacturer's written instructions.
 - 7. Use 3000-psi, 28-day compressive-strength concrete and reinforcement as specified in Division 03 Section "Cast-in-Place Concrete Miscellaneous Cast-in-Place Concrete."

3.16 ERECTION OF METAL SUPPORTS AND ANCHORAGES

- A. Refer to Division 05 Section "Metal Fabrications" for structural steel.
- B. Cut, fit, and place miscellaneous metal supports accurately in location, alignment, and elevation to support and anchor HVAC materials and equipment.
- C. Field Welding: Comply with AWS D1.1.

3.17 ERECTION OF WOOD SUPPORTS AND ANCHORAGES

- A. Cut, fit, and place wood grounds, nailers, blocking, and anchorages to support, and anchor HVAC materials and equipment.
- B. Select fastener sizes that will not penetrate members if opposite side will be exposed to view or will receive finish materials. Tighten connections between members. Install fasteners without splitting wood members.
- C. Attach to substrates as required to support applied loads.

3.18 PIPE PRESSURE TESTS

- A. The following lines shall be tested at the stated pressure for the length of time note.
- B. Where leaks occur, the pipe shall be repaired and the tests repeated. No leaks shall be corrected by peening. Defective piping and joints shall be removed and replaced.

Testing	Testing	Pressure <u>Medium</u>	Time in <u>(PSIG)</u>	<u>Service Hours</u>
Chilled & Hot Water		Water	150	24
Domestic Hot & Cold Water		Water	150	24
Sanitary & Storm Piping		Water	Fill to top	24
Natural Gas			Air	100
Compressed Air			Air	24
				225
				24

3.19 TRAINING

- A. The contractor shall provide manufacturer's orientation training to the college maintenance personnel on the HVAC and plumbing systems.

3.20 GROUTING

- A. Mix and install grout for HVAC equipment base bearing surfaces, pump and other equipment base plates, and anchors.
- B. Clean surfaces that will come into contact with grout.
- C. Provide forms as required for placement of grout.
- D. Avoid air entrapment during placement of grout.
- E. Place grout, completely filling equipment bases.
- F. Place grout on concrete bases and provide smooth bearing surface for equipment.
- G. Place grout around anchors.
- H. Cure placed grout.

END OF SECTION

SECTION 230513 - MOTORS AND MOTOR CONTROLLERS VARIABLE FREQUENCY DRIVE

PART 1 - GENERAL

1.01 RELATED DOCUMENTS

- A. The requirements of the General Conditions and Supplementary Conditions apply to all work herein.
- B. The Basic Materials and Methods, Section 15050, are included as a part of this Section as though written in full in this document.

1.02 SCOPE

- A. Scope of the Work shall include the furnishing and complete installation of the equipment covered by this Section, with all auxiliaries, ready for owner's use.
- B. WORK SPECIFIED ELSEWHERE:
 - 1. Painting
 - 2. Automatic temperature controls.
 - 3. Power control wiring to motors and equipment.

1.03 WARRANTY

- A. Warrant the Work specified herein for one year and motors for five years beginning on date of substantial completion against becoming unserviceable or causing an objectionable appearance resulting from either defective or non-conforming materials and workmanship.

1.04 SUBMITTALS

- A. SHOP DRAWINGS: Indicate size material, and finish. Show locations and installation procedures. Include details of joints, attachments, and clearances.
- B. PRODUCT DATA: Submit schedules, charts, literature, and illustrations to indicate the performance, fabrication procedures variations, and accessories.
- C. MOTOR NAMEPLATE INFORMATION: Manufacturer's name, address, utility and operating data.
- D. Refer to Division 1 for additional information.

1.05 DELIVERY AND STORAGE

- A. DELIVERY: Deliver clearly labeled, undamaged materials in the manufacturers' unopened containers.
- B. TIME AND COORDINATION: Deliver materials to allow for minimum storage time at the project site. Coordinate delivery with the scheduled time of installation.
- C. STORAGE: Store materials in a clean, dry location, protected from weather and abuse.

PART 2 - PRODUCTS

2.01 ELECTRIC MOTORS

- A. APPROVED MANUFACTURERS: Provide motors by a single manufacturer as much as possible.
 - 1. Baldor.
 - 2. Allis-Chalmers.

3. Siemens-Allis.
 4. Gould.
 5. General Electric.
 6. Westinghouse.
- B. TEMPERATURE RATING: Provide insulation as follows:
1. CLASS B: 40 degrees C maximum.
 2. CLASS F:
 - a. Between 40 degrees C and 65 degrees C maximum.
 - b. Totally enclosed motors.
- C. STARTING CAPABILITY: As required for service indicated five starts minimum per hour.
- D. PHASES AND CURRENT: Verify electrical service compatibility with motors to be used.
1. UP TO 1/2 HP: Provide permanent split, capacitor-start single phase with inherent overload protection.
 2. 1/2 HP AND LARGER: Provide squirrel-cage induction polyphase.
 3. Provide two separate windings on 2-speed polyphase motors.
 4. Name plate voltage shall be the same as the circuit's normal voltage, serving the motor.
- E. SERVICE FACTOR: 1.15 for polyphase; 1.35 for single phase.
- F. FRAMES: U-frames 1.5 h.p. and larger.
- G. BEARINGS: Provide sealed re-greasable ballbearings; with top mounted alemite lubrication fittings and bottom side drains minimum average life 100,000 hours typically, and others as follows:
1. Design for thrust where applicable.
 2. PERMANENTLY SEALED: Where not accessible for greasing.
 3. SLEEVE-TYPE WITH OIL CUPS: Light duty fractional hp. motors or polyphase requiring minimum noise level.
- H. ENCLOSURE TYPE: Provide enclosures as follows:
1. CONCEALED INDOOR: Open drip proof.
 2. EXPOSED INDOOR: Guarded.
 3. OUTDOOR TYPICAL: Type II. TEFC.
 4. OUTDOOR WEATHER PROTECTED: Type II. TEFC.
 5. EXPLOSION PROOF
- I. OVERLOAD PROTECTION: Built-in sensing device for stopping motor in all phase legs and signaling where indicated for fractional horse power motors.
- J. NOISE RATING: "Quiet" except where otherwise indicated.
- K. EFFICIENCY: Provide premium high efficiency motors in accordance with minimum full load efficiency listed in the following table, when tested in accordance with IEEE Test Procedure 112A, Method B, including stray load loss measure.

<u>HP</u>	<u>RPM (Syn)</u>	<u>NEMA Frame</u>	<u>Percent Efficiency</u>	<u>Percent Power Factor</u>
1	1800	143T	85.5	84
1-1/2	1800	145T	86.5	85
2	1800	145T	86.5	85
3	1800	182T	89.5	86
5	1800	184T	89.5	87
7-1/2	1800	213T	91.0	86

10	1800	215T	91.7	85
15	1800	256T	93.0	85
20	1800	256T	93.0	86
25	1800	284T	93.6	85
30	1800	286T	94.1	88
40	1800	324T	94.1	83
50	1800	326T	94.5	85

2.02 MOTOR CONTROLLERS (STARTERS)

- A. All motor controllers (for equipment furnished under Division 15) shall be furnished under Division 16 and installed under Division 16 unless otherwise noted on the plans.
- B. Motor starters shall be furnished as follows.
 1. GENERAL: Motor starters shall be Square D Company Class 853C across-the-line magnetic type, full-voltage, non-reversing (FVNR) starter. All starters shall be constructed and tested in accordance with the latest NEMA standards, sizes and horsepower. IEC sizes are not acceptable. Starters shall be mounted in a general purpose dead front, painted steel enclosure and surface-mounted. Provide size and number of poles as shown and required by equipment served. Provide two speed, two winding or two speed, single winding motor starter as required for two speed motors.
 2. CONTACTS: Magnetic starters contacts shall be double break solid silver alloy.
 3. All contacts shall be replaceable without removing power wiring or removing starter from panel. The starter shall have straight-through wiring. OPERATING COILS: Operating coils shall be 120 volts and shall be of molded construction. When the coil fails, the starter shall open and shall not lock in the closed position.
 4. OVERLOAD RELAYS: Provide manual reset, trip-free Class 20 overload relays in each phase conductor in of all starters. Overload relays shall be melting alloy type with visual trip indication. All 3 phase and single phase starters shall have one overload relay in each underground conductor. Relay shall not be field adjustable from manual to automatic reset. Provide 6 overload relays for two speed motor starters.
 5. PILOT LIGHTS: Provide a red running pilot light for all motor starters. Pilot lights shall be mounted in the starter enclosure cover. Pilot lights shall be operated from an interlock on the motor starter and shall not be wired across the operating coil.
 6. CONTROLS: Provide starters with HAND-OFF-AUTOMATIC switches. Coordinate additional motor starter controls with the requirements of Division 15. Motor starter controls shall be mounted in the starter enclosure cover.
 7. CONTROL POWER TRANSFORMER: Provide a single-phase 480 volt control power transformer with each starter for 120 volt control power. Connect the primary side to the line side of the motor starter. The primary side shall be protected by a fuse for each conductor. The secondary side shall have one leg fused and one leg grounded. Arrange transformer terminals so that wiring to terminals will not be located above the transformer.
 8. AUXILIARY CONTACTS: Each starter shall have one normally open and one normally closed convertible auxiliary contact in addition to the number of contacts required for the "holding interlock", remote monitoring, and control wiring. In addition, it shall be possible to field-install three more additional auxiliary contacts without removing existing wiring or removing the starter from its enclosure.
 9. UNIT WIRING: Unit shall be completely pre-wired to terminals to eliminate any interior field wiring except for line and load power wiring and HVAC control wiring.
 10. ENCLOSURES: All motor starter enclosures shall be NEMA 1, general purpose enclosures or NEMA-3R if mounted exposed to high moisture conditions. Provide NEMA 4X when located by cooling towers.

11. POWER MONITOR: Provide a square "D" 8430 MPS phase failure and under-voltage relay, base and wiring required for starters serving motors 10 horse power and larger. Set the under-voltage setting according to minimum voltage required for the motor to operate within its range.
- C. APPROVED MANUFACTURERS: Controller numbers are based on first named manufacturer. Provide one of the following manufacturer's.
 1. Siemens.
 2. Square D.
 3. General Electric.

2.03 COMBINATION MOTOR STARTERS

- A. GENERAL: Combination motor starters shall consist of a magnetic starter and a fusible or non-fusible disconnect switch in a dead front, painted steel NEMA 1 enclosure unless otherwise noted and shall be surface-mounted. Size and number of poles shall as shown and required by equipment served. Combination motor starters shall be as specified for motor starters in Paragraph 2.01/B, except as modified herein.
- B. DISCONNECT SWITCH: Disconnect switches shall be as specified in Section 16000.
- C. APPROVED MANUFACTURERS: Controller numbers are based on first named manufacturer. Provide one of the following manufacturer's.
 1. Seimens.
 2. Square D.
 3. General Electric.

2.04 VARIABLE FREQUENCY DRIVES

- A. MANUFACTURERS
 1. Siemens.
 2. ABB Industrial Systems.
 3. Toshiba International Corporation.
 4. Danfoss.
 5. It is preferred that new VFD's match existing VFD's on campus.
- B. Where shown on the drawings, adjustable frequency drives shall have the following features:
 1. The AFD shall be rated for 480 Vac (optional input voltages of 208, 240, 380 and 575 Vac). The AFD shall provide microprocessor-based control for three-phase induction motors. The controller's full load output current rating shall be based on 40° C - 50° C ambient and 10 kHz switching frequency below 40Hp (CT)/50 Hp (VT) and 3.6 kHz switching frequency 40Hp (CT)/50 Hp (VT) and above to reduce motor noise and avoid increased motor losses.
 2. The AFDs shall be of the Pulse Width Modulated (PWM) design converting the utility input voltage and frequency to a variable voltage and frequency output via a two-step operation. Adjustable Current Source AFDs are not acceptable. Insulated Gate Bipolar Transistors (IGBTs) shall be used in the inverter section. Bipolar Junction Transistors, GTOs or SCRs are not acceptable. The AFDs shall run at the above listed switching frequencies.
 3. The AFD's shall have efficiency at full load and speed that exceeds 95% for AFDs below 15 Hp and 97% for drives 15 Hp and above. The efficiency shall exceed 90% at 50% speed and load.
 4. The AFDs shall maintain the line side displacement power factor at no less than 0.96, regardless of speed and load.

5. The AFDs shall have a one (1) minute overload current rating of 150% and a two (2) second overload current rating of 250% for constant torque drives. The AFDs shall have a one (1) minute overload current rating of 110% for variable torque drives.
6. The AFDs shall be capable of operating any NEMA design B squirrel cage induction motor, regardless of manufacturer, with a horsepower and current rating within the capacity of the AFD.
7. The AFD's shall have an integral EMI/RFI filter as standard.
8. The AFD's shall limit harmonic distortion reflected onto the utility system to a voltage and current level as defined by IEEE 519 for general systems applications, by utilizing the standard 3% nominal impedance integral ac three-phase line reactor.
9. Any harmonic calculations shall be done based on the kVA capacity, X/R ratio and the impedance of the utility transformer feeding the installation, as noted on the drawings, and the total system load. The calculations shall be made with the point of common coupling being the point where the utility feeds multiple customers.
10. Total harmonic distortion shall be calculated under worst-case conditions in accordance with the procedure outlined in IEEE standard 519-1992. Copies of these calculations are to be made available upon request. The contractor shall provide any needed information to the AFD supplier three (3) weeks prior to requiring harmonic calculations.
11. The system containing the AFDs shall comply with the 5% level of total harmonic distortion of line voltage and the line current limits as defined in IEEE 519-1992. If the system cannot meet the harmonic levels with the AFDs provided with the standard input line reactor or optional input isolation transformer, the AFD manufacturer shall supply an eighteen pulse, multiple bridge rectifier ac to dc conversion section with phase shifting transformer for all drives 50 Hp and above. This eighteen-pulse rectifier converter shall result in a multiple pulse current waveform that will more nearly approximate a true sine-wave to reduce voltage harmonic content on the utility line. The phase shifting transformer shall be of a single winding type to optimize its KVA rating and harmonic cancellation capability. Harmonic filters are not acceptable for drives 50 Hp and above.
12. The AFD's shall be able to start into a spinning motor. The AFDs shall be able to determine the motor speed in any direction and resume operation without tripping. If the motor is spinning in the reverse direction, the AFDs shall start into the motor in the reverse direction, bring the motor to a controlled stop, and then accelerate the motor to the preset speed.
13. Standard operating conditions shall be:¹
 - a. Incoming Power: Three-phase, 208 - 240 / 380 - 500 / 525 - 690 Vac (+10% to -15%) and 50/60 Hz (+/-5 Hz) power to a fixed potential DC bus level.
 - b. Frequency stability of +/-0.05% for 24 hours with voltage regulation of +/-1% of maximum rated output voltage.
 - c. Speed regulation of +/- 0.5% of base speed.
 - d. Load inertia dependant carryover (ride-through) during utility loss.
 - e. Insensitive to input line rotation.
 - f. Humidity: 0 to 95% (non-condensing and non-corrosive).
 - g. Altitude: 0 to 3,300 feet (1000 meters) above sea level.
 - h. Ambient Temperature: -10 to 50 °C (CT), -10 to 40 °C (VT).
 - i. Storage Temperature: -40 to 60 °C.
14. Control Functions
 - a. Frequently accessed AFD programmable parameters shall be adjustable from a digital operator keypad located on the front of the AFD. The AFDs shall have a 3 line

alphanumeric programmable display with status indicators. Keypads must use plain English words for parameters, status, and diagnostic messages. Keypads that are difficult to read or understand are not acceptable, and particularly those that use alphanumeric code and tables. Keypads shall be adjustable for contrast with large characters easily visible in normal ambient light.

- b. The keypad shall include a Local/Remote pushbutton selection. Both start/ stop source and speed reference shall be independently programmable for Keypad, Remote I/O, or FieldBus.
 - c. The keypad shall have copy / paste capability.
 - d. Upon initial power up of the AFD, the keypad shall display a start up guide that will sequence all the necessary parameter adjustments for general start up.
 - e. Standard advanced programming and trouble-shooting functions shall be available by using a personal computer's RS-232 port and Windows™ based software. In addition the software shall permit control and monitoring via the AFD's RS232 port. The manufacturer shall supply a diskette with the required software. An easily understood instruction manual and software help screens shall also be provided. The computer software shall be used for modifying the drive setup and reviewing diagnostic and trend information as outlined in this section through section 18.
 - f. The operator shall be able to scroll through the keypad menu to choose between the following:
 - (1) Monitor
 - (2) Operate
 - (3) Parameter setup
 - (4) Actual parameter values
 - (5) Active faults
 - (6) Fault history
 - (7) LCD contrast adjustment
 - (8) Information to indicate the standard software and optional features software loaded.
15. The following setups and adjustments, at a minimum, are to be available:
- a. Start command from keypad, remote or communications port
 - b. Speed command from keypad, remote or communications port
 - c. Motor direction selection
 - d. Maximum and minimum speed limits
 - e. Acceleration and deceleration times, two settable ranges
 - f. Critical (skip) frequency avoidance
 - g. Torque limit
 - h. Multiple attempt restart function
 - i. Multiple preset speeds adjustment
 - j. Catch a spinning motor start or normal start selection
 - k. Programmable analog output
 - l. DC brake current magnitude and time
 - m. PID process controller
16. The AFDs shall have the following system interfaces:
- a. Inputs – A minimum of six (6) programmable digital inputs, two (2) analog inputs and serial communications interface shall be provided with the following available as a minimum:
 - (1) Remote manual/auto

- (2) Remote start/stop
 - (3) Remote forward/reverse
 - (4) Remote preset speeds
 - (5) Remote external trip
 - (6) Remote fault reset
 - (7) Process control speed reference interface, 4-20mA_{dc}
 - (8) Potentiometer and 1-10V_{dc} speed reference interface
 - (9) RS232 programming and operation interface port
 - (10) Serial communications port
- b. Outputs – A minimum of two (2) discrete programmable digital outputs, one (1) programmable open collector output, and one (1) programmable analog output shall be provided, with the following available at minimum.
- (1) Programmable relay outputs with one (1) set of Form C contacts for each, selectable with the following available at minimum:
 - a) Fault
 - b) Run
 - c) Ready
 - d) Reversed
 - e) Jogging
 - f) At speed
 - g) Torque Limit Supervision
 - h) Motor rotation direction opposite of commanded
 - i) Over temperature
 - (2) Programmable open collector output with available 24V_{dc} power supply and selectable with the following available at minimum:
 - j) Fault
 - k) Run
 - l) Ready
 - m) Reversed
 - n) Jogging
 - o) At speed
 - p) Torque Limit Supervision
 - q) Motor rotation direction opposite of commanded
 - r) Over temperature
 - (3) Programmable analog output signal, selectable with the following available at minimum:
 - s) Motor current
 - t) Output frequency
 - u) Frequency reference
 - v) Motor speed
 - w) Motor torque
 - x) Motor power
 - y) Motor voltage
 - z) DC-bus voltage
 - aa) AI1
 - bb) AI2

cc) PT100 temperature

dd) FB digital input 4

17. Monitoring and Displays

a. The AFD's display shall be a LCD type capable of displaying three (3) lines of text and the following thirteen (13) status indicators:

- (1) Run
- (2) Forward
- (3) Reverse
- (4) Stop
- (5) Ready
- (6) Alarm
- (7) Fault
- (8) I/O terminal
- (9) Keypad
- (10) Bus/Comm
- (11) Local (LED)
- (12) Remote (LED)
- (13) Fault (LED)

b. The AFD's keypad shall be capable of displaying the following monitoring functions at a minimum:

- (1) Output frequency
- (2) Frequency reference
- (3) Motor speed
- (4) Motor current
- (5) Motor torque
- (6) Motor power
- (7) Motor voltage
- (8) DC-bus voltage
- (9) Unit temperature
- (10) Calculated motor temperature
- (11) Voltage level of analog input
- (12) Current level of analog input
- (13) Digital inputs status
- (14) Digital and relay outputs status
- (15) Analog Iout

18. Protective Functions

a. The AFD shall include the following protective features at minimum:

- (1) Overcurrent
- (2) Overvoltage
- (3) Inverter fault
- (4) Undervoltage
- (5) Input phase loss
- (6) Output phase loss
- (7) Undertemperature
- (8) Overtemperature
- (9) Motor stalled
- (10) Motor overtemperature
- (11) Motor underload
- (12) Logic voltage failure
- (13) Microprocessor failure

- b. The AFD shall provide ground fault protection during power-up, starting, and running. AFD's with no ground fault protection during running are not acceptable.
19. Diagnostic Features
- a. Fault History.
 - (1) Record and log faults
 - (2) Indicate the most recent first, and store up to 30 faults.
20. Optional features must be included in the AFD
- a. HMCP or thermal magnetic breaker to provide a disconnect means. Operating handle shall protrude the door. The disconnect shall not be mounted on the door. The handle position shall indicate ON, OFF, and TRIPPED condition. The handle shall have provisions for padlocking in the OFF position with at least three (3) padlocks. Interlocks shall prevent unauthorized opening or closing of the AFD door with the disconnect handle in the ON position. This shall be defeatable by maintenance personnel.
 - b. AC input line current limiting fuses shall provide a means of disconnecting the AFD from the line under fault conditions.
 - c. Three contactor bypass shall include a drive input disconnect, an AFD input isolation contactor, bypass contactor and an AFD output contactor that is electrically and mechanically interlocked with the bypass contactor. This circuit shall include control logic, status lights and motor overcurrent relays. The complete bypass system (Inverter-Off-Bypass)¹ (Hand-Off-Auto with Inverter-Bypass)¹ selector switch(es), and inverter/bypass pilot lights shall be packaged with the AFD. The unit may be set up for (Manual)¹ (Automatic)¹ bypass operation upon an AFD trip.
 - d. Fused space heaters with thermostat for oversize enclosures to minimize condensation potential upon drive shutdown.
 - e. Motor over current relay to provide motor overcurrent sensing of a given level of load current.
 - f. Motor filter for use on motor cable runs exceeding 100 feet for motors with a peak voltage insulation rating less than 1600 Vac.
 - (1) The dv/dt filter shall be located at the AFD and shall reduce the dv/dt clamp any voltage overshoots of the AFD output. It will return the energy in the voltage overshoots to the AFD's dc bus. A power dissipative resistance device is not acceptable. Filter shall be a Cutler-Hammer Motor_x type.¹
21. The AFD manufacturer shall maintain, as part of a national network, engineering service facilities within 250 miles of project to provide start-up service, emergency service calls, repair work, service contracts, maintenance and training of customer personnel.

PART 3 - EXECUTION

3.01 FACTORY TESTING

- A. The following standard factory tests shall be performed on the equipment provided under this section. All tests shall be in accordance with the latest version of UL and NEMA standards.
 - 1. All printed circuit boards shall be functionally tested via automatic test equipment prior to unit installation.
 - 2. After all tests have been performed, each AFD shall undergo a burn-in test. The drive shall be burned in at 100% inductive or motor load without an unscheduled shutdown.
 - 3. After the burn-in cycle is complete, each AFD shall be put through a motor load test before inspection and shipping.
- B. The manufacturer shall provide three (3) certified copies of factory test reports.

- C. VFD's shall be tied to energy management system.

3.02 FIELD QUALITY CONTROL

- A. Provide the services of a qualified manufacturer's employed Field Service Engineer to assist the Contractor in installation and start-up of the equipment specified under this section. Field Service personnel shall be factory trained with periodic updates and have experience with the same model of AFD's on the job site. Sales representatives will not be acceptable to perform this work. The manufacturer's service representative shall provide technical direction and assistance to the Contractor in general assembly of the equipment, installation as specified in manufacturer's installation instructions, wiring, application dependant adjustments, and verification of proper AFD operation.
- B. The following minimum work shall be performed by the Contractor under the technical direction of the manufacturer's service representative.
 - 1. Inspection and final adjustments.
 - 2. Operational and functional checks of AFDs and spare parts.
 - 3. The contractor shall certify that he has read the drive manufacturer's installation instructions and has installed the AFD in accordance with those instructions.
- C. The Contractor shall provide three (3) copies of the manufacturer's field start-up report before final payment is made.

3.03 MAINTNANCE / WARRANTY SERVICE

- A. Warranty to commence 12 months from the date of start-up, not to exceed 36 months from the date of shipment, and include all parts, labor, and travel time.

3.04 FIELD TESTING

- A. Optional field testing
 - 1. The AFD manufacturer shall perform harmonic measurements at the point where the utility feeds multiple customers (PCC) to verify compliance with IEEE519-1992. A report of the voltage THD and current TDD shall be sent to the engineer. The contractor shall provide labor, material, and protection as needed to access the test points. The readings shall be taken with all drives and all other loads at full load, or as close as field conditions allow.

3.05 TRAINING

- A. The Contractor shall provide a training session for up to 2 owner's representatives for one workday with a maximum of 2 trips at a job site location determined by the owner. Training and instruction time shall be in addition to that required for start-up service.
- B. The training shall be conducted by the manufacturer's qualified representative.
- C. The training program shall consist of the following:
 - 1. Instructions on the proper operation of the equipment.
 - 2. Instructions on the proper maintenance of the equipment.

END OF SECTION

SECTION 230529 - HANGERS AND SUPPORTS FOR HVAC PIPING AND EQUIPMENT

PART 1 - GENERAL

1.01 RELATED DOCUMENTS

- A. Furnish and install supports, anchors and sleeves applicable to mechanical, plumbing, and fire protection systems, including:
 - 1. Pipe, duct, and equipment hangers, supports, and associated anchors.
 - 2. Equipment bases and supports.
 - 3. Sleeves and seals.
 - 4. Flashing and sealing equipment and pipe stacks.

1.02 WORK FURNISHED BUT INSTALLED UNDER OTHER SECTIONS

- A. Provide hanger and support inserts and sleeves and coordinate placement into formwork.

1.03 RELATED SECTIONS

- A. Section 230700 – HVAC Insulation.
- B. Section 230716 – HVAC Equipment Insulation.
- C. Section 230719 – HVAC Piping Insulation.

PART 2 - PRODUCTS

2.01 MANUFACTURERS

- A. Grinnell
- B. Superstruct
- C. Unistrut
- D. FireSage
- E. Link-Seal
- F. 3M

2.02 PIPE HANGERS AND SUPPORTS

- A. Hangers for Non-Insulated Pipe Sizes 1/2 to 4-Inch: Provide malleable iron, adjustable swivel, split ring.
- B. Hangers for Insulated Pipe Sizes 1/2 to 3 Inches and Non-Insulated Pipe Sizes 6 Inches and Over: Galvanized carbon steel, adjustable, clevis.
- C. Supports for Single Hot Pipe Sizes 4 Inches and Over and Cold Pipe Sizes 4 Inches and Over; Carbon Steel Roller.
- D. Multiple or Trapeze Hangers: Galvanized steel channels with welded spacers and hangers rods, cast iron roll and stand for sizes 4 inches and larger hot water piping and 4 inches and larger chilled water piping.
- E. Wall Support for Pipe Sizes to 3 Inches: Cast iron hook.
- F. Wall Support for Pipe Sizes to 4 Inches and Over: Welded steel bracket and wrought steel clamp; adjustable steel yoke and cast iron roll.
- G. Vertical Support: Steel riser clamp.

- H. Floor Support for Pipe Sizes 4 Inches and All Cold Pipe Sizes: Cast iron adjustable pipe saddle, locknut nipple, floor flange, and concrete pier or steel support.
- I. Floor Support for Pipe Sizes 6 Inches and Over: Adjustable cast iron roll and stand, steel screws, and concrete pier or steel support.
- J. Design hangers without disengagement of supported pipe.
- K. Copper Pipe Support and Hangers: Carbon steel ring, adjustable, copper plated.
- L. Shield for Insulated Piping 2 Inches and Smaller: 18 gauge galvanized steel shield over insulation in 180-degree segments, minimum 12 inches long at pipe support.
- M. Shield for Insulated Piping 2-1/2 Inch and Larger (Except Cold Water Piping): Use pipe support inserts. Galvanized steel shields in 180-degree segments in accordance with following table:

2.03 HANGER RODS

- A. Steel, threaded both ends, threaded one end or continuous threaded. Galvanized or cadmium plated.

2.04 INSERTS

- A. Provide malleable iron case of galvanized steel shell and expander plug for threaded connection with lateral adjustment, top slot for reinforcing rods, lugs for attaching to forms, size inserts to suit threaded hanger rods.

2.05 FLASHING

- A. Metal Flashing: 26 gauge galvanized steel.
- B. Flexible Flashing: 47 mil thick sheet butyl: compatible with roofing.
- C. Caps: Steel, 22 gauge minimum; use 16 gauge at fire resistant elements.

2.06 EQUIPMENT BASE AND SUPPORTS

- A. Provide 6" concrete pads and equipment bases for all outdoor equipment on grade, floor mounted equipment in main central plant area, areas with floor below grade, penthouse equipment rooms, floor mounted air handling units and where shown on Drawings.
- B. Provide prefabricated curbs or roof mounted equipment with the equipment. Equipment curb must compensate for slopped roof deck as required to set equipment level.

2.07 SLEEVES

- A. Sleeves for Pipes through Non-fire Rated Floors: Form with 16 gauge galvanized steel.
- B. Sleeves for Pipes through Non-fire Rated Beams, Walls, Above Grade: Form with 18 gauge

Pipe	Metal Gauge	Shield Length
2 1/2" to 5"	15	12"
6" to 12"	14	24"
Over 12"	12	24"

galvanized steel.

- C. Sleeves for Pipes through Fire Rated and Fire Resistive Floors and Walls, and Fireproofing: Provide prefabricated fire rated sleeves including seals, UL listed; or provide Schedule 40 galvanized steel, sized for minimum 1 inch space between sleeve and carrier pipe.
- D. Sleeves for Pipe through Floor Supporting Riser Piping: Standard weight galvanized steel pipe.
- E. Sleeves for Pipes through Roof: Standard weight galvanized steel pipe.
- F. Sleeves for Round Ductwork: Form with galvanized steel.
- G. Sleeves for Rectangular Ductwork: Form with galvanized steel.
- H. Provide fire-stop compound at all penetrations of floor slabs or firewalls such that fire rating integrity of barrier is not lessened.
- I. Caulk: Caulk all sleeves water and airtight.
- J. Size sleeves large enough to allow for movement due to expansion and contraction. Provide for continuous insulation wrapping. Provide pipe sleeves one size larger than the pipe it serves, including insulation, except where "Link Seal" casing seals are used.
- K. Sleeves Penetration Walls Below Grade: Provide "Link-Seal" and sleeve as manufactured by Thunderline Corporation, Wayne, Michigan, for all pipes passing through walls below grade.

2.08 FINISHES

- A. Prime coat and paint exposed steel hangers and supports. Hangers and supports located in crawl spaces, pipe shafts, and suspended ceiling spaces are not considered exposed.
- B. Provide galvanized hangers and supports for all piping and ductwork located in crawlspace, pipe shafts, and above suspended ceiling spaces.
- C. Provide hanger rods, bolts, nuts, and all metal parts coated with the same material as hangers.

2.09 ANCHOR BOLTS

- A. Provide galvanized anchor bolts for all equipment placed on concrete pads or on concrete slabs of the size and number recommended by the manufacturer of the equipment.

PART 3 - EXECUTION

3.01 PIPE HANGERS AND SUPPORTS

- A. Support horizontal pipes as follows:

Pipe Size	Max. Hanger Spacing*	Hanger Diameter
1/2 to 1-1/4 inch	6'-6"	3/8"
1-1/2 to 2 inch	8'-0"	3/8"
2-1/2 to 3 inch	10'-0"	1/2"
4 to 6 inch	10'-0"	5/8"
8 to 12 inch	10'-0"	7/8"
14 inch and Over	14'-0"	1"
PVC, PVDF, PP	4'-0"	3/8"
C.I. Bell and Spigot (or No-Hug)	5'-0" and at Joints	5/8"
*Comply with NFPA 13 for fire protection pipe hanger spacing.		

- B. Install hangers to provide minimum 1/2-inch space between finished covering and adjacent work.
- C. Place a hanger within 12 inches of each horizontal elbow.
- D. Use hangers with 1-1/2 inch minimum vertical adjustment.
- E. Support horizontal cast iron pipe adjacent to each hub, with five feet maximum spacing between fingers.
- F. Support vertical piping at every floor. Support vertical cast iron pipe at each floor at hub.
- G. Where several pipes can be installed in parallel and at same elevation, provide multiple or trapeze hangers.
- H. Support riser piping independently of connected horizontal piping.
- I. Provide corrosion resistant hangers by Corr-Tech for all piping hangers in corrosive areas. Provide hanger rods, bolts, nuts and all metal parts coated with the same material as hangers.

3.02 DUCT SUPPORT SCHEDULE

- A. All horizontal ducts up to and including 40 inches in their greater dimension shall be supported by means of No. 18 U.S. gauge band iron hangers attached to the ducts by means of screws, rivets, or clamps and fastened to above inserts with toggle bolts, beam clamps or other approved means. Duct shall have at least one pair of supports 8' 0" on centers. Clamps shall be used to fasten hangers to reinforcing on sealed ducts.
- B. Horizontal ducts larger than 40 inches in their greatest dimension shall be supported by means of hanger rods bolted to angle iron trapeze hangers. Duct shall have at least one pair of supports 8' 0" on centers according to the following:

<u>Max. Duct</u> <u>Dimen.</u>	<u>Steel</u> <u>Rod</u>	<u>Galv. Steel</u> <u>Strap Width</u>	<u>Max.</u> <u>Spacing</u>	<u>Min.#</u> <u>Hngrs</u>	<u>Min.#</u> <u>Trapeze Size</u>
-----------------------------------	----------------------------	--	-------------------------------	------------------------------	-------------------------------------

0 through 18"	--	1" x 16 ga.	10'	2	--
19" through 36"	--	1" x 16 ga.	10'	2	--
37" through 60"	3/8"	1" x 16 ga.	8'	2	2" x 2" x 1/4"
61" through 120"	3/8"	1-1/2" x 12 ga.	8'	2	2" x 2" x 1/4"
121" through 240"	3/8"	--	4'	3	2-1/2" x 2-1/2" x 3/16"

3.03 INSERTS

- A. Provide inserts for placement in concrete formwork.
- B. Provide inserts for suspending hangers from reinforced concrete slabs and sides of reinforced concrete beams.
- C. Provide hooked rod to concrete reinforcement section for inserts carrying pipe over 4 inches.
- D. Where concrete slabs form finished ceiling, provide inserts flush with slab surface.
- E. Where inserts are omitted, drill through concrete slab from below and provide thru-bolt with recessed square steel plate and nut recessed into and grouted flush with slab.

3.04 FLASHING

- A. Provide flexible flashing and metal counter-flashing where sleeves, piping and ductwork penetrate weather or waterproofed walls, floors, and roofs.
- B. Flexible sheet flash and counter-flash all curbs for mechanical equipment on roof with sheet metal; seal watertight.

3.05 EQUIPMENT BASES AND SUPPORTS

- A. Coordinate installation of equipment bases of concrete type specified for all outdoor equipment on grade and floor mounted equipment in main central plant area, areas with floors below grade, penthouse equipment rooms floor mounted air handling units and where shown on drawings.
- B. Provide templates, anchor bolts, and accessories for mounting and anchoring equipment
- C. Construct support of steel members. Brace and fasten with flanges bolted to structure.
- D. Provide rigid anchors for pipes after vibration isolation components are installed.
- E. Provide base of a minimum height of 4 inches above finished grade and a width that projects a minimum of 3 inches beyond equipment on all sides. Bevel edges of base.
- F. Prepare surface under bases by cleaning, clearing, chipping and roughing.
- G. Provide curbs of 14 inches minimum height above roofing surface for installation of mechanical equipment on roof.

3.06 SLEEVES

- A. Provide sleeves for all pipe penetrations through walls, roof or slab above grade.
- B. Set sleeves in position in formwork. Provide reinforcing around sleeves.
- C. Extend sleeves through floors 2 inches above finished floor level. Caulk sleeves full depth and provide floor plate.
- D. Where piping or ductwork penetrates floor, ceiling wall, close off space between pipe or duct and adjacent work with fire stopping insulation and seal air tight. Provide close fitting metal collar or escutcheon covers at both sides of penetration. When penetration is through a fire

rated floor or wall, provide fire safing insulation so that the assembly when complete is UL listed and equals the fire rating of construction penetrated by the sleeve.

- E. Install chrome plated steel escutcheons at finished surfaces.
- F. Provide three 6 inch long reinforcing rods welded at 120-degree spacing to the sleeve on all sleeves supporting riser piping 4 inches and larger. Embed reinforcing rods in concrete or grout to existing concrete.
- G. Install sleeve assembly for walls below grade with 1/4-inch thick plate located in the middle of the wall.
- H. Neatly cut hose in existing walls, floors and roofs for placement of sleeves. Place sleeve and grout, and caulk annular space to provide finished appearance.
- I. Install pipe in sleeve so that neither the pipe nor its insulation touches the sleeve at any point.
- J. Seal space between pipe and sleeve watertight for all sleeves penetrating the roof.

3.07 ANCHOR BOLTS

- A. Locate position of anchor bolts by means of suitable templates.
- B. When equipment is placed on vibration isolators, secure equipment to the isolator and the isolator to the floor, pad or support as recommended by the vibration isolator manufacturer.

3.08 INSULATION SHIELDS

- A. Provide insulation shields at every hanger support.
- B. Provide shields of the proper length to distribute weight evenly and to prevent sagging or indentation of insulation at hanger.
- C. Install shield so that hanger is placed at the center of the shield.
- D. Attach shield to insulation with adhesive to prevent slippage or movement.

END OF SECTION

SECTION 230548 - VIBRATION CONTROLS FOR HVAC PIPING AND EQUIPMENT

PART 1 - GENERAL

1.01 DESCRIPTION

- A. Complete vibration isolation systems for equipment, piping and ductwork including:
 - 1. Vibration isolators.
 - 2. Foundations and supports.

1.02 RELATED WORK

- A. General conditions of the Contract and Division 1.
- B. Related Sections
 - 1.01 Noise Control,
 - 1.01 Concrete, Section 3.
- C. This section is supplementary to other sections of Division 15, except where conflict exists between Section 15070 and other sections of Division 15, this Section 15070 shall govern.

1.03 QUALITY ASSURANCE

- A. Manufacturer's Responsibilities
 - 1. Determine vibration isolation sizes and locations.
 - 2. Provide piping and equipment isolation systems as scheduled or specified.
 - 3. Guarantee specified isolation system deflection.
 - 4. Provide installation instructions and drawings.
 - 5. Unless otherwise indicated in the Vibration Isolation Schedule, substitution of "internally isolated" mechanical equipment in lieu of the specified isolation of this Section must be approved for individual equipment units, and is acceptable only if products provided strictly conform to these specifications.

1.04 SUBMITTALS

- A. Submit the following data, in a schedule, for approval, clearly identifying each item of equipment supported and the isolation to be installed at each point of support.
 - 1. Horsepower of each motor and rpm of both driven and driver, in each supported unit.
 - 2. Scheduled deflection of each isolator. Identification of each isolator to be selected by model number and spring color.
 - 3. Deflection of each isolator under the calculated load, actual loaded and unloaded measurable spring height.
 - 4. The loading at which each isolator would be fully compressed to solid.
- B. Shop Drawings, Supplemental to Division 1 Requirements
 - 1. Concrete and steel details for all inertia bases.
 - 2. Vibration isolation devices: Catalog cuts referencing isolator "type", isolation efficiencies, isolator deflections, and layout drawings for all pipes and ducts showing isolator location, sizes, deflection and dimensional data.

3. Reinforcing and template steels.
4. Quality assurance provisions.
- C. Samples
 1. Provide one sample of each type of vibration isolator in use on the project.
- D. Final Inspection Report
 1. Submit final inspection report as described in Item 3.4 of this Section.

PART 2 – PRODUCTS

2.01 MANUFACTURERS

- A. All vibration isolation products described in this section shall be the product of a single manufacturer. Subject to compliance with requirements specified herein, provide vibration isolation materials, bases and systems by one of the following or approved equal:
 1. Kinetics Noise Control, Inc.
6300 Irelan Place
Dublin, OH 43017
614-889-0480
 2. Mason Industries, Inc.
350 Rabro Drive
Hauppauge, NY 11788
631-348-0282
 3. Vibration Mountings & Controls, Inc. (a division of Aeroflex, Inc.)
113 Main Street
Bloomington, NJ 07403
973-838-1780
 4. Ventfabrics, Inc.
Chicago, IL
312-775-4477
 5. DuroDyne
Farmingdale, NY
516-249-9000
- B. Where listed, references are to Kinetics Noise Control, Inc. (K.N.C.), Mason Industries, Inc. (M.I.I), Vibration Mountings and Controls, Inc. (V.M.C.I), Ventfabrics, Inc. (VI), and DuroDyne (DD).

2.02 VIBRATION ISOLATOR GENERAL REQUIREMENTS

- A. All vibration isolators shall have either known un-deflected heights or other markings so that after adjustment, when carrying their load, the deflection under load can be verified, thus determining that the load is within the proper range of the device and that the correct degree of vibration isolation is being provided according to the design.
- B. All isolators shall operate in the linear portion of their load versus deflection curve. Load versus deflection curves shall be furnished by the manufacturer and shall be linear over a deflection range 50% above the design deflection.

2.03 VIBRATION ISOLATORS

A. Spring Types

1. Type "A": Spring isolators
 - a. Minimum diameter of 0.8 of the loaded operating height.
 - b. Corrosion resistance where exposed to corrosive environment with:
 - 1) Springs cadmium plated and neoprene coated.
 - 2) Hardware cadmium plated.
 - 3) All other metal parts hot dip galvanized.
 - c. Minimum additional travel to solid equal to 50% of the rated deflection.
 - d. Leveling device.
 - e. 1/4" thick neoprene acoustical base pad.
 - f. Designed and installed so that ends of springs remain parallel.
 - g. Spring mounts with springs welded to housing are not acceptable.
 - h. Non-resonant with equipment forcing frequencies or support structure natural frequencies.
 - i. One of the following:
 - Type SLF - M.I.I.
 - Type AC - V.M.C.I.
 - Type FDS - K.N.C.
2. Type "B": Spring isolators shall be the same as Type "A" except:
 - a. Where operating weight differs from installed weight, provide built-in adjustable limit stops to prevent equipment rising when weight is removed. All restraining bolts shall have large rubber grommets to provide cushioning in the vertical and horizontal modes. The hole through the bushing shall be a minimum of 3/4" larger in diameter than the restraining bolt.
 - b. A minimum of one layer of 1/4" neoprene base pad at the bottom of the mount.
 - c. Tapped holes in top plate for bolting to equipment.
 - d. Capable of supporting equipment at a fixed elevation during equipment erection.
 - e. One of the following:
 - Type SLR - M.I.I.
 - Products by V.M.C.I. or K.N.C. that meet the requirements listed above.
3. Type "C": Spring hanger rod isolators
 - a. Spring element seated on a steel washer reinforced neoprene cup.
 - b. Steel retainer box encasing the spring and neoprene cup.
 - c. The neoprene cup shall incorporate a neoprene bushing projecting through the lower rod hole of the steel retainer box to prevent steel-to-steel contact.
 - d. Spring diameters and hanger box lower hole size large enough to permit hanger rod to swing through a 30° arc before contacting the hole and short-circuiting the spring.
 - e. One of the following:
 - Type 30 - M.I.I.
 - Products by V.M.C.I. or K.N.C. that meet the requirements listed above.

B. Elastomer Types

1. All elastomer isolators shall incorporate the following:
 - a. Bolt holes for bolting to equipment base.
 - b. Bottom steel plates for bolting to sub-base as required.
 - c. Unit type design molded in black oil-resistant neoprene.
 - d. All metal surfaces shall be neoprene covered.
 - e. Neoprene to be not greater than 50 durometer.
 2. Type "D": Double deflection elastomer mount
 - a. Rated minimum deflection of 0.35".
 - b. One of the following:
 - Type ND - M.I.I.
 - Type RD - V.M.C.I.
 - Type RD - K.N.C.
 3. Type "E": Double deflection elastomer hanger rod isolators
 - a. Steel retainer box encasing neoprene mounting.
 - b. Molded unit type neoprene element with minimum deflection of 0.20".
 - c. Neoprene element to incorporate a neoprene bushing projecting through steel retainer box for the lower rod hole to prevent steel-to-steel contact.
 - d. Clearance between mounting hanger rod and steel retainer box.
 - e. One of the following:
 - Type HD - M.I.I.
 - Type RHD - V.M.C.I.
 - Type RH - K.N.C.
 - a. 3/4" minimum thickness
 - b. 50 psi maximum loading.
 - c. 0.1" deflection per pad thickness.
 - d. 1/16" galvanized steel plate between multiple layers of pad thickness where necessary to achieve scheduled deflection.
 - e. Suitable bearing plate to distribute load.
 - f. One of the following:
 - Type Super W- M.I.I.
 - Products by V.M.C.I. or K.N.C. that meet the requirements listed above.
 4. Type "F": Pad type neoprene mountings
- C. Combination Spring and Elastomer Types
1. Type "G": Combination spring/elastomer hanger rod isolators
 - a. Spring and neoprene isolator elements in a steel box retainer.
 - b. Characteristics of spring and neoprene as described in Type "C" and Type "E" isolators.
 - c. Factory pre-loading to 75% of rated load (for pre-compressed springs).
 - d. One of the following:
 - Type 30N (PC30N for pre-compression) - M.I.I.
 - Products by V.M.C.I. or K.N.C. that meet the requirements listed above.

2. Type "H": Thrust restraints
 - a. Use on all fan heads and axial or centrifugal fans where the air thrust exceeds 10% of the equipment weight. Manufacturer is responsible for making this determination.
 - b. The thrust restraint consists of a Type "A" isolator with the same deflection as specified in the schedule for the mountings or hangers.
 - c. Spring element contained within a steel frame designed so it can be preset for thrust at the factory and adjusted in the field to allow for a maximum of 1/4" movement at start and stop.
 - d. Assembly furnished with one rod and angle brackets for attachment to both equipment and ductwork or the equipment and the structure.
 - e. Restraints attached at the centerline of thrust and symmetrically on either side of the unit.
 - f. One of the following:
Type WB - M.I.I
Products by V.M.C.I. or K.N.C. that meet the requirements listed above.

D. Piping Anchors

1. Type "J": All-directional piping anchors
 - a. Mountings to consist of a telescoping arrangement of two sizes of steel tubing separated by a minimum of 1/2" thick, heavy duty neoprene and canvas duck isolation pad.
 - b. Provide vertical restraints by similar material arranged to prevent vertical travel in either direction.
 - c. Allowable load on the isolation material shall not exceed 500 psi.
 - d. One of the following:
 - e. Type ADA - M.I.I
Products by V.M.C.I. or K.N.C. that meet the requirements listed above.

2.04 ROOFTOP SPRING CURBS

A. Rooftop spring curbs

1. Type "RSC": Curb mounted isolation base
 - a. Integral spring and weather curb arrangement that fits under the equipment to be isolated and over the curb.
 - b. Top and bottom members constructed of extruded aluminum and connected by a flexible, water-proof neoprene membrane. The aluminum members seal against the curb with continuous closed cell neoprene sponge. The extruded aluminum top member shall overlap the bottom member to provide water runoff should the seals fail. Corners shall be mitered and welded.
 - c. Springs cadmium plated or epoxy powder coated with deflections as called out in the schedule and 50% additional travel to solid. Spring diameters of no less than 0.8 of the spring height at rated load. All spring locations shall have access ports with removable waterproof covers.
 - d. Where called out in the drawings, the system should incorporate (for improved airborne acoustical isolation), two layers of staggered joint 5/8" drywall directly attached to the top of the roof structure within the curb surrounding the ducts. All interfaces

should be caulked. In addition, 4" thick, 1.5 lb/ft³ density glass or mineral fiber shall cover the drywall surface under the unit and all sides of the plenum.

e. One of the following:

Type RSC-db - M.I.I. (*consultant: remove "-db" if note d. is not used*)

Products by V.M.C.I. or K.N.C. that meet the requirements listed above.

2.05 EQUIPMENT BASES

A. Integral Structural Steel Bases

1. Type "B-1A"

- a. Reinforced as required to prevent base flexure at startup and misalignment of drive and driven units.
- b. Fan bases complete with motor slide rails.
- c. Depth equal to 1/10 of the longest dimension of the base, not exceeding 14".
- d. Height saving brackets shall be employed in all mounting locations.
- e. Isolators shall be Type "A".
- f. One of the following:

Type WFSL - M.I.I.

Type SFB - K.N.C.

Type WFB - V.M.C.I.

B. Concrete Inertia Bases

1. Type "B-2A"

- a. Manufacturer to provide steel pouring forms for floating concrete bases. Bases for split case pumps shall provide support for suction and discharge elbows. Bases for fans shall contain motor slide rails as required.
- b. Forms shall include minimum concrete reinforcing as required to prevent flexure, misalignment of drive and driven unit or stress transferal into equipment.
- c. Forms shall be provided with steel templates to hold anchor bolt sleeves and anchor bolts while concrete is being placed.
- d. Base depth shall be a minimum of 1/12 of the longest dimension of the base, but not less than 6". Base depth need not exceed 12" unless specifically requested.
- e. Height saving brackets shall be employed to maintain 1" clearance from bottom of base to floor.
- f. Bases shall incorporate Type "A" isolators provided by vibration control supplier.
- g. Base ready for concrete pour; concrete weighing not less than 140 lbs per cubic foot by others.
- h. One of the following:

Type BMK/KSL - M.I.I.

Type CIB-H,CIB-L - K.N.C.

Type WPF - V.M.C.I.

2.06 FLEXIBLE CONNECTORS

A. Neoprene Connectors for General Piping

1. Type "FC-1"

- a. Twin sphere connector constructed of neoprene and kevlar tire chord reinforcement.

- b. Straight connectors to have two spheres.
- c. The raised face rubber flanges must encase solid steel rings to prevent pull out. Flexible cable is not acceptable.
- d. Minimum ratings shall be 200 psi at 220°F with minimum safety factor of 3:1.
- e. Size 12" and larger to employ control cables with end fittings isolated from anchor plates by means of 1/2" bridge bearing neoprene washer bushings designed for a maximum 1000 psi.
- f. Connector to be one of the following or equal:
- g. Type SFDEJ - M.I.I.
Products by V.M.C.I. or K.N.C. that meet the requirements listed above.

B. Flexible Stainless Hoses

2. Type "FC-2"

- a. Braided flexible metal hose to be installed in pairs to accept movement in all directions.
- b. Pipe sizes less than 3" to be provided with male nipple fittings.
- c. 3" and larger pipe size to be provided with fixed steel flanges.
- d. Suitable for operating pressure with 4:1 minimum safety factor.
- e. Minimum length for given diameter of pipe shall be (pipe diameter in inches x length in inches): 1/2x9, 3/4x10, 1x11, 1-1/4x12, 1-1/2x13, 2x14, 2-1/2x18, 3x14, 4x15, 5x19, 6x20, 8"x22", 10x26, 12x28, 14x30, 16x32.
- f. Connectors to be one of the following or equal:
Type BSS - M.I.I.
Products by V.M.C.I. or K.N.C. that meet the requirements listed above.

C. Flexible Duct Connections to Fans

1. Type "FC-3"

- a. 30 ounce wovenglass fiber coated with neoprene, sewn together at the edges and joints.
- b. 6" long and held in place with 1" wide bands of 12 ga. galvanized steel bolted to duct and to outlets and inlets of the units and fans with 1/8" stove bolts, 5" o.c. Metal connections 3" wide on either side of the flexible material, as provided by the manufacturer, may also be used.
- c. One of the following or equal:
VentglassVI
Insulflex - DD

PART 3 - EXECUTION

3.01 INSPECTION

- A. Examine all work prepared by others to receive work of this Section and report problems or defects affecting installation to the General Contractor/Construction Manager for correction.
- B. Inspect all components of the Work to insure no damage has occurred during shipment or storage.

INSTALLATION

- A. Install vibration isolation devices and systems in accordance with the manufacturer's instructions.
- B. Floor Mounted Equipment
 - 1. Housekeeping pads of thickness indicated on drawings or in specifications:
 - a. Over entire floor area of supported equipment.
 - b. Supporting all vibration isolation devices and bases.
 - c. Keyed with hairpins as required to be integral with the structural slab.
 - d. Increased to 8" thick for chillers.
 - 2. Concrete per specification describing requirements.
- C. General Equipment Isolation
 - 1. Provide 2" operating clearance between concrete inertia bases and housekeeping pad and 1" clearance between equipment or structural bases and housekeeping pad.
 - 2. Isolation mounting deflection (minimum) as specified or scheduled on manufacturer's certified drawings.
 - 3. Position equipment, structural base and concrete bases on blocks or wedges at proper operating height.
 - 4. Provide operating load conditions prior to transferring base isolator loads to springs and removing wedges.
 - 5. Electrical conduit connections to isolated equipment shall be looped or installed with flexible conduit to allow free motion of isolated equipment.
 - 6. Install equipment directly on isolation system. Support rails between the equipment and isolators should not be used.
 - 7. Verify all installed isolators and mounting systems permit equipment motion in all directions.
 - 8. Adjust or provide additional resilient restraints to limit startup equipment lateral motion to 1/4".
 - 9. Prior to startup, clean out all foreign matter between bases and equipment. Verify that there are no isolation short circuits in the base or isolators.
 - 10. No rigid connections between rotating or vibrating equipment and building structure shall be made that degrades the vibration isolation system herein specified.
 - 11. Coordinate work with other trades to avoid rigid contact with the "building". Inform other trades following, such as plastering, drywall, electrical or sheet metal, to avoid any contact which would reduce the vibration isolation.
 - 12. Bring to the Architect's attention immediately, prior to installation, any conflicts with other trades which will result in unavoidable rigid contact with equipment or piping as described herein, due to inadequate space or other unforeseen conditions. Corrective work necessitated by conflicts after installation shall be at the contractor's expense.
 - 13. Correct, at no additional cost, all installations which are deemed defective in workmanship or material as a result of project completion inspection or subsequent inspections due to owner complaints within a period of one year following acceptance.
- D. Piping and Ductwork Isolation
 - 1. Use factory preloading for the first three hangers from all equipment containing rotating or vibrating parts, such as pumps, AHUs, chillers, etc. and for all piping greater than 6" in diameter. The first four isolators from the equipment shall have the same static deflection

of the isolator used for the equipment itself. Subsequent isolators shall have a static deflection of 1/2 that of connected equipment with a minimum of 1”.

2. Isolate all water (hot, chilled, and condenser) and steam piping greater than 2” in diameter in mechanical rooms and outside of mechanical rooms within 50 feet of the mechanical room enclosure with Type “G” hanger rod isolators with a minimum static deflection of 1”. Isolate same piping 2” in diameter or less with Type “E” hanger rod isolators with a minimum static deflections of 0.20”.
3. Isolate all ductwork in mechanical rooms and outside of equipment rooms within 50 feet of mechanical room enclosure with Type “C” hanger rod isolators with 1” static deflection.
4. Isolate piping where exposed to the exterior of the building and supported by the roof with Type “B” isolators with 1” minimum static deflection.
5. Isolate ductwork where exposed to the exterior of the building and supported by the roof with Type “B” isolators with 1” static deflection.
6. Isolate compressed air piping from compressor discharge to receiver with Type “C” isolator with 1” static deflection.
7. Isolate compressed air piping at discharge from the compressor with two flexible connectors Type “FC-2” 90o to each other.
8. Support water and steam piping in shafts and floor supports entering shaft with Type “F” isolators (2 layers).
9. Type “J” all-directional piping anchors are required for the entire rise of all pipes that are connected to equipment containing rotating or vibrating parts and begin their rise within 50’ of the equipment.
10. Provide flexible connections “FC-1” at all connections of pipe to equipment containing rotating or vibrating parts, such as pumps, AHUs, chillers, etc.
11. Position isolators:
 - a. Close to building structure.
 - b. Between building structure and supplementary steel if required.
 - c. Not to contact acoustic rated walls.
12. Suspend isolators from rigid and massive support points.
13. Adjust as required all isolators to eliminate all contact of the isolated rod with the hanger rod box retainer or short circuiting of the spring.
14. Supplementary steel to be sized for a maximum deflection of 0.08” at the center span.

3.02 ADJUST AND CLEAN

- A. Check and adjust all isolators to insure there is no short circuiting such as:
 1. Hanger rods touching boxes.
 2. Hold-down bolts not released.
 3. Bolts touching springs.
 4. Springs and/or neoprene overloaded.
 5. Bottom neoprene pads short circuited by welding bottom plate to structure.
 6. Isolation device touching adjacent structures.

3.03 FINAL INSPECTION

- A. On completion of installation of all vibration isolation devices herein specified, the local representative of the isolation materials manufacturer shall inspect the completed systems and report, in writing, any installation error, improperly selected isolation devices or other faults in the system that could affect the performance of the system. Contractor shall submit a report to the Architect, including the manufacturer's representative's final report, indicating all isolation reported as properly installed or requiring correction and include a report by the Contractor on steps taken to properly complete the isolation work.
- B. The Acoustical Consultant will subsequently inspect the systems for conformance to specifications and for proper installation methods. Contractor shall replace or repair, at his expense, any isolation devices that deviate from the specifications, approved shop drawings, and manufacturer's recommendations as a result of this inspection.

VIBRATION ISOLATION SCHEDULE			
Equipment Type		Isolator Type	Min. Static Deflection (in inches)
Air Handling Units – Internal Fan Isolation		A, FC-3, H	2.0
Air Handling Units – Casing Isolation		D, FC-1, FC-3	0.35
Roof-Top Exhaust Fans		RSC, FC-3	1.0
Roof-top Units		RSC, FC-3, H	2.0
VAV Terminal Units		G, FC-3	1.0
Fan Coil Unit		G, FC-3	1.0
Pumps		B-2A, FC-1	1.0
Condensing Units		A, FC-3, H	1.0
Piping	As described in Item 3.2.D.		1.0
Ductwork	As described in Item 3.2.D.		1.0

ISOLATOR TYPES

- A) Free-Standing Spring
- B) Free-Standing Spring with Vertical Limit Restraint
- C) Spring Hanger
- D) Double Deflection Neoprene Mount
- E) Double Deflection Neoprene Hanger
- F) Neoprene Pad
- G) Combination Spring/Neoprene Hanger
- H) Thrust Restraint
- J) All Directional Piping Anchor
- RSC) Curb Mounted Isolation Base
- B-1A) Integral Structural Steel Base
- B-2A) Concrete Inertia Base with Free-Standing Spring
- FC-1) Neoprene Piping Flexible Connection
- FC-2) Braided Piping Flexible Connection
- FC-3) Flexible Duct Connector

END OF SECTION

SECTION 230593 - TESTING, ADJUSTING AND BALANCING FOR HVAC

PART 1 - GENERAL

1.01 RELATED DOCUMENTS

- A. Contract Documents, General Requirements for Building Construction and Related Work, apply to work specified in this section.

1.02 REFERENCES

- A. AABC - National Standards for Testing and Balancing Heating, Ventilating, and Air Conditioning Systems, Latest Edition.
- B. ASHRAE - 2011 HVAC Applications Chapter 34: Testing, Adjusting and Balancing.
- C. ANSI/ASHRAE Standard 111-2007 - Practices for Measurement, Testing, Adjusting and Balancing of Buildings, Heating, Ventilation, Air Conditioning and Refrigeration Systems.
- D. AABC. 1997. Testing and Balancing Procedures.

1.03 SCOPE

- A. An independent Testing, Adjusting and Balancing (TAB) Contractor for the HVAC systems shall be selected by Owner. The TAB agency will be contracted by COH and paid by the General Contractor under TAB allowance of \$35,000 included within the contract price.
- B. This section provides for the testing, balancing, and commissioning of all systems and equipment.
- C. These tests are required to determine that all systems and equipment involved may be safely energized and equipment.
- D. Perform tests by and under the supervision of fully experienced and qualified personnel. Advise each respective manufacturer's representative of tests on their equipment.
- E. Record all test data.
- F. Each section of Divisions 22 and 23 that has the products or systems listed herein, incorporate this section by reference and is incomplete without the required tests stated herein.
- G. This Section includes testing, adjusting, balancing, and commissioning HVAC systems and alarm point reporting verification to produce design objectives, including the following:
 - 1. Balancing airflow and water flow within distribution systems, including sub-mains, branches, and terminals, to indicated quantities according to specified tolerances.
 - 2. Adjusting total HVAC systems to provide indicated quantities.
 - 3. Measuring electrical performance of HVAC equipment.
 - 4. Setting quantitative performance of HVAC equipment.
 - 5. Verifying that automatic control devices are functioning properly and perform their intended functions.
 - 6. Calibrating automatic temperature control sensors.
 - 7. Commissioning the HVAC system.
 - 8. Verification of building alarm and alarm remote monitoring.

1.04 QUALIFICATIONS

- A. The Firm shall be one which is organized to provide professional services of this specified type in the State of Texas and as a minimum shall have one (1) professional engineer licensed in the State of Texas, with current registration, to perform such professional services. This engineer shall be personally responsible for developing the job site data as required in the test procedures outlined in these Specifications.
- B. The Firm shall have operated a minimum of five (5) years under its current Firm name, and shall be in good standing with the State of Texas, Franchise Tax Board. The firm shall submit their full incorporated name, Charter Number and Taxpayer's I.D. Number for proper verification of the firm's status.
- C. All personnel used on the job site shall be either professional engineers or engineering technicians, who shall have been permanent, full time employees of the firm for a minimum of six (6) months prior to the start of work for this specific project.
- D. The TAB firm shall submit biographical data on the individual proposed who will directly supervise the TAB work, as well as other personnel scheduled to perform the technical work under the contract. It shall also submit a background record of at least five years of specialized experience in the field of air hydronic system balancing, and shall possess properly calibrated instrumentation. The supervisory personnel for the TAB firm shall be registered engineers in the mechanical field and all of the employees used in the TAB firm shall be permanent, full-time employees of the firm.

1.05 REPORTS

- A. Submit test report forms for review a minimum of 90 prior to requesting a final review by the Architect/ Engineer.
- B. Furnish six (6) individually bound copies of test data. Neatly type and arrange data. Include with the data the date tested, personnel present, weather conditions, nameplate record of test instrument and list all measurements take, both prior to and after any corrections are made to the system. Record all failures and corrective action taken to remedy incorrect situation.
- C. The Architect will retain on (1) copy and the Engineer will retain one (1) copy. The remaining four (4) copies will be returned to the Contractor for inclusion in the operation and maintenance manuals. Refer to Division 01 – Closeout Submittals.

1.06 VIBRATION TESTS

- A. Location of Points for Roof top Units and Air Handling Unit Fans and all other Fans:
 - 1. Fan bearing, drive end.
 - 2. Fan bearing, opposite end.
 - 3. Motor bearing, center (if applicable)
 - 4. Motor bearing, drive end.
 - 5. Motor bearing, opposite end.
- B. Test Readings.
 - 1. Horizontal, velocity and displacement.
 - 2. Vertical, velocity and displacement.
 - 3. Azial, velocity and displacement.
- C. Normally acceptable readings, velocity and acceleration.
- D. Unusual conditions at time of test.

- E. Vibration sources (if non-complying)

PART 2 - PRODUCTS

Not Used.

PART 3 - EXECUTION

3.01 PREPARATION

- A. Follow industry standard practices and procedures for testing, balancing, and commissioning as listed in paragraph 1.3 above.
- B. The A/E must be notified a minimum of 72 hours prior to any tests being conducted.
- C. The TAB Contractor must be notified a minimum of five working days prior to conduction any duct leakage tests and same must be present to witness all duct leakage tests.

3.02 PRELIMINARY PROCEDURES FOR AIR SYSTEM BALANCING

- A. Before operating the system, perform these steps:
 1. Obtain design drawings and specifications and become thoroughly acquainted with the design intent.
 2. Obtain copies of approved shop drawings of all exhaust fans, air handling equipment, air distribution devices (supply, return, and exhaust) and temperature control diagrams.
 3. Compare design to installed equipment and field installations.
 4. Walk the system from the system air handling equipment to terminal units to determine variations of installation from design.
 5. Check filters for cleanliness.
 6. Check dampers (both volume and fire) for correct and locked position, and temperature control for completeness of installation before starting fans.
 7. Prepare report test sheets for both fans and air distribution devices. Obtain manufacturer's air distribution device area factors (Ak) and recommended procedures for testing. Prepare a summation of required air distribution device air flow volume to permit a crosscheck with required fan air flow volume.
 8. Determine best locations in main and branch duct for most accurate duct traverses.
 9. Place air distribution device and manual balancing dampers in the full open position.
 10. Prepare schematic diagrams of system "as-built" duct and piping layouts to facilitate reporting.
 11. Lubricate all motors and bearings.
 12. Check fan belt tension and pulley alignment.
 13. Check fan rotation

3.03 PERFORMING TESTING, ADJUSTING, AND BALANCING

- A. Perform testing and balancing procedures on each system identified, in accordance with the detailed procedures outlined in the referenced standards.
- B. Cut insulation, duct, and piping for installation of test probes to the minimum extent necessary to allow adequate performance of procedures.
- C. Patch insulation, duct, and housings, using materials identical to those removed.
- D. Seal ducts and piping, and test for and repair leaks.

- E. Seal insulation to re-establish integrity of the vapor barrier.
- F. Mark equipment settings, including damper control positions, valve indicators, fan speed control levers, and similar controls and devices, to show final settings. Mark with paint or other suitable, permanent identification materials.
- G. Retest, adjust, and balance systems subsequent to significant system modifications, and resubmit test results

3.04 FINAL AIR BALANCE

- A. **General:** When systems are complete and ready for operation, the TAB Consultant will perform a final air balance for all air systems and record the results. The outside, supply, exhaust and return air volume for each air handling unit, supply fan and exhaust fan and the supply, exhaust or return air volume for each distribution device shall be adjusted to within $\pm 5\%$ of the value shown on the drawings. Air handling unit and fan volumes shall be adjusted by changing fan speed and adjusting volume dampers associated with the unit. Air distribution device volume shall be adjusted using the spin-in tap damper for flexible duct connected devices and the device OBD for duct connected devices. Air distribution devices shall be balanced with air patterns as specified. Duct volume dampers shall be adjusted to provide air volume to branch ducts where such dampers are shown. The general scope of balancing by the TAB Consultant will include, but is not limited to, the following.
- B. **Filters:** Check air filters and filter media and balance only system with essentially clean filters and filter media. The Division 23 Contractor shall install new filters and filter media prior to the final air balance.
- C. **Blower Speed:** Measure RPM at each fan or blower to design requirements. Where a speed adjustment is required, the Division 23 Contractor shall make any required changes.
- D. **Ampere Readings:** Measure and record full load amperes for motors.
- E. **Static Pressure:** Static pressure gains or losses shall be measured across each supply fan, cooling coil, heating coil, return air fan, air handling unit filter and exhaust fan. These readings shall be measured and recorded for this report at the furthest air device or terminal unit from the air handler supplying that device. Static pressure readings shall also be provided for systems which do not perform as designed.
- F. **Equipment Air Flow:** Adjust and record exhaust, return, outside and supply air CFM (s) and temperatures, as applicable, at each fan, blower and coil.
- G. **Coil Temperatures:** Set controls for full cooling and for full heating loads. Read and record entering and leaving dry bulb and wet bulb temperatures (cooling only) at each cooling coil, heating coil and HVAC terminal unit. At the time of reading record water flow and entering and leaving water temperatures (In variable flow systems adjust the water flow to design for all the above readings).
- H. **Zone Air Flow:** Adjust each zone of multizone units, each HVAC terminal unit and air handling unit for design CFM.
- I. **Outlet Air Flow:** Adjust each exhaust inlet and supply diffuser, register and grille to within $\pm 5\%$ of design air CFM. Include all terminal points of air supply and all points of exhaust. Note: For Labs and Rooms that are negative exhaust air flow shall be set to design +10% and supply to design -5%. Positive areas will have opposite tolerances.
- J. **Pitot Tube Traverses:** For use in future troubleshooting by maintenance personnel, all exhaust ducts, main supply ducts and return ducts shall have air velocity and volume measured and

recorded by the traverse method. Locations of these traverse test stations shall be described on the sheet containing the data.

K. Maximum and minimum air flow on terminal boxes.

3.05 MECHANICAL EQUIPMENT

A. Verify the following:

1. Equipment is operable and in safe and normal condition.
2. Temperature control systems are installed complete and operable.
3. Proper thermal overload protection is in place for electrical equipment.
4. Final filters are clean and in place. If required, install temporary media in addition to final filters.
5. Duct systems are clean of debris.
6. Correct fan rotation.
7. Fire and volume dampers are in place and open.
8. Coil fins have been cleaned and combed.
9. Access doors are closed and duct end caps are in place.
10. Air outlets are installed and operable.
11. Duct system leakage has been minimized.
12. Pretest components in the VFD. Provide factory certification of testing the entire VFD with varying induction motor loads for 24 hours prior to shipment.
13. Proper sequencing and operation of all DDC Control System components and equipment as required by ASHRAE Standard on Total Building Mechanical System Commissioning.
14. Perform sound power level tests and provide required data on each occupied space adjacent to, above, or below mechanical/ air handling unit equipment rooms.
15. Perform vibration test and provide required data on each piece of air handling/ ventilation equipment or fan. Vibration testing must be complete in compliance with the requirements of ASHRAE – 1999 HVAC applications Handbook Chapter 46, Sound and Vibration Control and the maximum listed RMS values listed herein.

B. Duct Leakage

1. Test all supply air ductwork, to include, but not limited to, downstream of all single zone and multi-zone air handling units, downstream of all VAV air handling units and upstream of fan powered terminal units at 2-1/2 inches of static pressure (except where this requirement would exceed the ductwork design pressure classification) to have a total leakage value not to exceed 2% of the total system airflow.
2. Test all supply, return, and exhaust air ductwork, to include, but not limited to, downstream of fan coil units and fan powered terminal units, upstream of air handling units, and upstream and downstream (where applicable) of fans at 1-1/2 inches of static pressure to have a total leakage value not to exceed 2% of the total system design airflow.
3. Ductwork that initially fails these tests shall be replaced, modified, resealed, etc. as required to meet the leakage requirement and then re-tested to ensure compliances.

3.06 TESTING OF TEMPERATURE CONTROL SYSTEMS

A. In the process of performing the TAB work, the TAB Agency shall:

1. Work with the temperature control contractor to ensure the most effective total system operation within the design limitations, and to obtain mutual understanding of intended control performance.

2. Verify that all control devices are properly connected.
3. Verify that all dampers, valves and other controlled devices are operated by the intended controller.
4. Verify that all dampers and valves are in the position indicated by the controller (open, closed or modulating).
5. Verify the integrity of valves and dampers in terms of tightness of close-off and full-open positions. This includes dampers in multizone units, terminal boxes and fire/smoke dampers.
6. Observe that all valves are properly installed in the piping system in relation to direction of flow and location.
7. Observe the calibration of all controllers.
8. Verify the proper application of all normally opened and normally closed valves.
9. Observe the locations of all thermostats and humidistats for potential erratic operation from outside influences such as sunlight, drafts or cold walls.
10. Observe the locations of all sensors to determine whether their position will allow them to sense only the intended temperatures or pressures of the media. Control Contractor will relocate as deemed necessary by the TAB Agency.
11. Verify that the sequence of operation for any control mode is in accordance with approved shop drawings and specifications. Verify that no simultaneous heating and cooling occurs.
12. Verify that all controller set points meet the design intent.
13. Check all dampers for free travel.
14. Verify the operation of all interlock systems
15. Perform variable volume system verification to assure the system and its components track with changes from full flow to minimum flow

3.07 PLUMBING EQUIPMENT

- A. Plumbing System – Perform operational tests to demonstrate satisfactory operation. Include the following information:
 1. Time date and duration of test for each system.
 2. Water pressures at the most remote and highest fixtures.
 3. Operation of each fixture and fixture trim.
 4. Operation of each valve and faucet.
 5. Pump suction and discharge pressures.
 6. Temperature of each domestic hot water supply.
 7. Operation of each floor drain by flooding and water.
 8. Operation of each vacuum breaker and backflow preventer.
 9. Piping systems: Test results of all pressure tests.
 10. Pumps: Field check alignment of all couplings and pump vibration.
- B. Natural Gas and Compressed Air Piping
 1. Apply pressure equal to 1 1/2 times the operating pressure with 50 psig as a minimum. Utilize oil free dry air or gaseous nitrogen and hold pressure for one hour with no drop in pressure. Repair all leaks.
 2. Record pressure reading at entrance to building on main line with valves to equipment shutoff. Read each indicating instrument at 2 hour intervals for a period of four hours and a final reading at the end of 24 hours.

- C. Sanitary Waste, Vent and Storm Drainage Systems: Test systems throughout upon completion of the rough work and without fixtures connected. Test underground lines with not less than 15 feet hydrostatic head and prove leak free for one hour. Plug and test sanitary system by floors and prove leak free for one hour. Flush floor drains for proper operation.
- D. Domestic Water System
 1. Test hot and cold water piping prior to being insulated. Test in place with 125 psi hydrostatic test at the low points and maintain pressure without pumping for one hour.
 2. Completely flush water circulating system with water with strainers removed. Fill system with water for 48 hours minimum with a 1-inch open bleed valve or until bleed water is clear. After completing this operation, chemically treat system, clean strainer and open to central system.
 3. Thoroughly flush all domestic water piping and tanks and then treat and sterilize with HTH or a liquid chlorine gas and water solution, or direct chlorine gas placed in the upstream side in amounts to give a dosage of 50 ppm chlorine calculated on the volume of water the piping will contain. A minimum residual of 5 ppm chlorine shall remain in all parts of the system for a minimum of 24 hours. After sterilizing, flush all lines thoroughly. The foregoing shall be in accordance with local utility company requirements.
 4. Under no circumstances shall the Contractor permit the use of any portion of the domestic water system until it has been properly sterilized and certified same by the local water department.
 5. Provide Test results of disinfection of domestic water piping system.

3.08 FIRE PROTECTION

- A. Fire Protection System
 1. Hydrostatically test all fire protection piping in accordance with NFPA. Test all standpipe fire protection and all sprinkler piping with 200 psi hydrostatic test at the lowest level with pressure maintained without loss for two hours.
 2. Submit certified laboratory performance test curves showing pump performance characteristics with pump and system operating point plotted. Include NPSH when applicable.
 3. Conduct a field acceptance test in accordance with NFPA20. Provide notice to the pump manufacturer's engineer and A/E so that they can be present during the field test.
 4. Submit written report indicating the result of the test, certified by those present that test was performed and that system performance was acceptable.
 5. Schedule test to allow A/E to witness. Give written notice of the date of test a minimum of three working days in advance.
 6. Upon completion of test, prepare Contractors Material and Test Certificate and submit to A/E. Furnish copies to the authority having jurisdiction.

END OF SECTION

SECTION 230713 - HVAC INSULATION

PART 1 - GENERAL

1.01 SECTION INCLUDES

- A. Furnish and install thermal insulation for mechanical and plumbing piping systems including jackets and accessories.
- B. HVAC system includes horizontal roof drain, lines, and waste lines which receive condensate from air handling units or evaporators.

1.02 RELATED SECTIONS

- A. Section 090190 – Maintenance of Painting and Coatings.
- B. Section 210529 – Hangers and Supports for HVAC Piping and Equipment.
- C. Section 210553 – Identification for HVAC Piping and Equipment.

1.03 REFERENCES

- A. ASTM C 178 – Steady State Heat Flux Measurements and Thermal Transmission Properties by Means of the Guarded-HOT-Plate Apparatus.
- B. ASTM C 195 – Mineral Fiber Thermal Insulation Cement.
- C. ASTM C 533 – Calcium Silicate Block and Pipe Thermal Insulation.
- D. ASTM C 534 - Preformed Flexible Elastomeric Cellular Thermal Insulation.
- E. ASTM C 547 – Mineral Fiber Preformed Pipe Insulation.
- F. ASTM C 591 – Preformed Cellular Polyurethane Thermal Insulation.
- G. ASTM C 1126 – Rigid Cellular Phenolic Thermal Insulation.
- H. ASTM B 209 – Aluminum and Aluminum-alloy Sheet and Plate.
- I. ASTM E 84 – Surface Burning Characteristics of Building Materials.
- J. ASTM E 96 –Water Vapor Transmission of Materials.

1.04 SUBMITTALS

- A. Include product description, list of materials, and thickness for each service and locations.
- B. Include detail drawings of insulation dams.

1.05 QUALITY ASSURANCE

- A. Application Company Qualifications: The installing company must be solely and exclusively in the business of insulation installation for the previous consecutive five year period. The installing company must also be regularly engaged in installing the specific specified insulation material types on projects of equal or greater magnitude and scope as this project for the previous consecutive five year period. Documentation of the above listed requirements must be submitted prior to insulation material submitted.
- B. Application Personnel Qualifications: The installing company must provide qualified installation personnel on this project jobsite directly employed by them who are skilled and proficient at installing the specific specified insulation Material types.

- C. Any material found, by the A/E, to be improperly installed or not installed in total compliance with the specific installation instructions and methods (written or implied) of the material manufacturer must be removed by the installing company. The preparation instructions must be followed prior to the re-installation of the insulation material using the correct installation instructions and methods of the material manufacturer.
- D. All material (to include, but not limited to, insulation, jackets, facings, coatings, mastics, adhesive, sealants, etc.) Installed inside the building must have a certified and tested composite flame spread/smoke developed rating of 25/50 in accordance with ASTM E84.

1.06 ENVIRONMENTAL REQUIREMENTS

- A. Maintain ambient temperatures and conditions required by manufacturers of adhesive and insulation.

PART 2 - PRODUCTS

2.01 MANUFACTURERS

- A. Insulation
 1. Owens-Corning Fiberglass Corporation.
 2. UpJohn CRP/DOW Chemical Company.
 3. Knuff Corporation.
 4. FGH Fabricators, Inc.
 5. Armstrong.
- B. Jackets
 1. Childers Products Company.
 2. PABCO.
 3. RFR Products, Inc.

2.02 PIPE INSULATION

- A. Type A: Chilled and Hot Water Piping - "FOAMGLAS" as manufactured by the Pittsburgh Corning Corporation or "KOOLPHEN K" as manufactured by Kooltherm Insulation and shall be installed on chilled water lines in tunnels and in buildings up to the building circulating pump. The "FOAMGLAS" "StrataFab System" may also be installed on larger pipe sizes as appropriate. Prior to application of any insulation, all metal surfaces shall be thoroughly cleaned. The metal shall then be primed with an asphaltic primer consisting of one (1) coat of Foster No. 60-26 Primer or Pittcote 300 Primer. Cleaning and priming specified in this paragraph is not included in requirements for "Cleaning and Painting" specified in other sections of the Specifications. Regular "FOAMGLAS" insulation shall be applied to the piping with butt joints staggered and all joints tightly butted and sealed with a 1/4" bead of joint sealer 1/2" from outside edge. Hold in place with 14 gauge copper clad wire 9" o.c. After insulation has been wired in place, a 1/16" minimum thick, 3" wide band of asphaltic vapor seal mastic shall be brushed or troweled on the outside of the "FOAMGLAS" insulation at the approximate location of the aluminum bands. (Note that the asphaltic material specified in this paragraph is intended to be an exception to the flame spread and smoke generation limitations found elsewhere in this specification.) An aluminum jacketing 0.016" thickness equal to Premetco precast, pre rolled Z-lock Kraft paper lined pipe covering with zee type closure and 3/4" wide snap straps with permanent sealant shall then be fitted to O.D. of insulation and applied over the insulated pipe with 3" end and side caps secured with aluminum bands on 12" centers. Longitudinal joint of aluminum jacketing shall be placed with overlap directed to bottom of

pipe. Any voids in “”the completed installation of the insulation shall not be filled with vapor seal coating but shall be eliminated by refitting or replacing insulation.

- B. Type B: Elastomer, closed cell, flexible, insulation; ASTM E 96, maximum vapor transmission rating of 0.20 pers; ASTM C 177; ‘k’ value of 0.27 at 75 degrees F.

2.03 DUCT INSULATION MATERIALS

- A. Type C: Flexible Fiberglass Duct Insulation (Indoor application): ASTM C 553, Type I, Class B-4, 2 " thick, 1.5 PCF density, minimum R-6 (installed) with foil faced continuous vapor barrier. This application is limited to concealed indoor locations only.
- B. Type D: Rigid Fiberglass Duct Insulation (Indoor application): ASTM C 612, Class 1, 2" thick, 3.0 PCF density, for both supply and exhaust round ducts exposed to view locations, or spaces without ceilings. Round duct insulation shall be E. O. Wood Rigid wrap® for all round ducts in areas without ceiling.
- C. Type E: Foam Glass Duct Insulation (Outdoor application): ASTM C 240, Type I.
- D. Jackets for Duct Insulation: ASTM C 921, Type I for duct with temperatures below ambient; Type II for duct with temperatures above ambient.
- E. Jackets for outdoor Duct Insulation: Encase exterior duct insulation with 16 MIL aluminum jacket with "Z" closures for weather-proof construction.
- F. Duct Insulation Accessories: Provide bands, wires, tape, anchors, corner angles and similar accessories as recommended by insulation manufacturer for applications indicated.
- G. Mechanical Fasteners:
 - 1. Gemco Type IH-A from Goodloe E. Moore, Inc., Danville, IL 800-331-1164.
 - 2. Eckoustic-Klip from Eckel Industries Inc., Cambridge, MA 617-491-3221.
 - 3. INC Stick-Pin from Industrial Noise Control Inc. Addison, IL 312-620-1998.
- H. Duct Insulation Compounds: Provide cements, adhesives, coatings, sealers, protective finishes and similar compounds as recommended by insulation manufacturer for applications indicated.
 - 1. 15-141 from King Co., St. Louis, MO 314-772-9953.
 - 2. Tuffbond from Goodloe E. Moore, Inc., Danville, IL 800-331-1164.
 - 3. INC C-700 from Industrial Noise Control Inc., Addison, IL 312-620-1998.
- I. All external duct wrap shall be 2 " thick, 1.0 P.C.F. density minimum, and is required on all and supply air duct that also meets with the minimum R-value per International Energy Code 2006. External duct wrap shall be with foil faced continuous vapor barrier. This application is limited to concealed indoor locations only

2.04 DUCTWORK JACKETS

- A. Interior, Concealed Applications
 - 1. Type D Insulation: one and a half (1 ½) pounds per cubic feet minimum density semi-rigid glass fiber. Provide factory applied ASJ white kraft foil vapor barrier. Type B Insulation: Finish coat is not required.
 - 2. Insulate fittings, joints and valves with molded insulation of like material and thickness as adjoining pipe. Use insulating cement to fill voids and cracks. Finish with #10 glass membrane and Childers #CP-30 L.O. vapor barrier mastic. PVC jackets may be used with glass membrane and vapor barrier mastic.
- B. Interior, Exposed Applications

1. Three (3) pounds per cubic feet minimum density semi-rigid glass fiber. Provide factory applied ASJ white kraft foil vapor barrier. Also finish with canvas jacket or #10 glass membrane with Childers CP-50 or approved equal finish. Size for finish painting. Verify jacket is suitable for applications. Insulation shall be E. O. Wood "Rigid-Wrap".
2. Finish coat on 8 oz canvas shall be Childers CP-50
3. Insulated fittings, joints and valves with molded insulation of like material and thickness as adjoining pipe. Use insulating cement to fill voids and cracks. Finish with #10 glass membrane and Childers CP-30 L.O vapor barrier mastic. PVC jackets may be used with glass membrane and vapor barrier mastic.

C. Exterior Applications

1. Insulate piping system as indicated under interior, exposed applications. Finish with #10 glass membrane and Childers CP-11 prior to final jacket installation.
2. Provide electric heat tracing for all piping, as indicated on drawings.
3. Cover with 0.02 inch thick aluminum or stainless steel jacket having integral moisture barrier with seams located at 2 or 10 o'clock position of horizontal piping. All laps must be minimum 2".

D. Jacket Materials

1. Factory Applied Jackets: White kraft bonded to reinforced foil vapor barrier with self-sealing adhesive joints.
2. PVC Jackets: One piece, pre-molded type, to meet flame spread and smoke developed rating of 25/50 in accordance with ASTM E 84.
3. Canvas Jackets: UL listed treated cotton fabric, 6 ounces per square
4. Fiberglass Cloth Reinforcing Mesh: #10 glass cloth with minimum weight of 3.9 ounces per square yard.
5. Aluminum Jackets: (Indoor applications exposed to view) ASTM B 209, 0.020 inch thick; smooth finish with factory applied moisture barrier.
6. Stainless Steel Jackets: (Outdoor applications) Type 304 stainless steel; 0.010 inch thick; smooth finish.

2.05 ACCESORIES

- A. Insulation Bands: 3/4 inch wide; 0.015 inch thick galvanized steel, stainless steel or 0.007 inch thick aluminum.
- B. Metal Jacket Bands: 3/8 inch wide; 0.015 inch thick aluminum or 0.010 inch thick stainless steel to match jacket.
- C. Insulating Cement: ASTM C 195; hydraulic setting mineral wool; Ryder One-Coat.
- D. Sealants: Used at valve, fittings and where insulation is terminated. Brush apply sealant to end of insulation and continued along pipe surface. Provide Childers CP-30 L.O. sealant.
- E. Adhesives: Used to adhere the longitudinal lap seam of vapor barrier jackets and at butt joints between insulation or fitting covers. Provide Childers CP-82 or approved equal as general purpose adhesive. Use Childers CP-97 fibrous adhesive for calcium silicate or when adhering pipe saddles and shields to the insulation.
- F. Primers: Provide Childers CP-50 diluted 50% with water primer to cover insulating cements prior to finish coating.

- G. Finish: Provide Childers CP-30 L.O. as a general purpose finish to coat the longitudinal seams and butt joints of vapor barrier jackets or glass cloth jackets. Use Childers CP-50 reinforced with glass cloth as an adhesive and seizing for canvas and in other locations as indicated.

PART 3 - EXECUTION

3.01 PIPE PREPARATION

- A. Thoroughly clean all surfaces to be insulated as required to remove all oil, grease, loose scale, rust, and foreign matter. Piping must be completely dry at the time of application. The installation of piping insulation associated with an operating chilled water system is strictly prohibited. Provide primer coat on all piping, to include field welds and over factory applied paint/ coating, in total compliance and compatible with and approved by the Engineer prior to installation of insulation (No Exceptions). Install insulation material only after all performance tests on piping have been completed and approved by the Engineer (No Exceptions).

3.02 PIPE INSTALLATION

- A. Install materials in complete and total compliance with the specific manufacturer's installation instructions.
- B. Continue vapor barrier through wall and floor penetrations.
- C. In exposed piping, locate insulation and cover seams in least visible locations.
- D. Insulate fittings, valves, flanges and strainers. On flexible connections, expansion joints and unions, bevel and seal ends of insulation and continue sealant a minimum of 4 inches along the piping.
- E. Provide dams in insulation at intervals not to exceed 20 feet to prevent migration of condensation or leakage.
- F. Provide an insert of same thickness and contour as adjoining insulation, between support shield and piping, and under the finish jacket, on piping 2 1/2 inch diameter or larger, to prevent insulation from sagging at support points. Provide inserts for 180-degree arc and not less than the length of the pipe support shield or minimum 12 inches long (whichever is greater) manufactured of 5.0# density cellular phenolic insulation material suitable for the planned temperature range. Factory fabricated inserts with integral galvanized pipe saddles are recommended. Adhere pipe support shield to insulation with adhesive.
- G. Neatly finish and seal insulation at supports, protrusions and interruptions. Maintain vapor barrier with finish coat.
- H. Paint exposed pipe insulation in total compliance with Section 210553 and Section 090190.

3.03 DUCT SYSTEM INSULATION

- A. Insulation Omitted: Do not insulate exhaust duct unless otherwise indicated on the drawings or specified, or lined duct.
- B. Cold Ducts: Temperatures below the space dew point shall have the insulation vapor barrier be continuous and unbroken through inside walls, sleeves and floor openings. Where connection is made to fire or fire/smoke damper in wall or floor the vapor barrier must extend to the wall or floor to prevent ambient air water vapor from condensing on the cold surfaces of the fire damper.
- C. Duct Wrap: Fasten all longitudinal and circumferential laps with outward clinching staples 3" on center. On rectangular ducts over 24" wide, apply as above and hold insulation in place on bottom side with mechanical pins and clips on 12" centers.

- D. Duct Wrap: Seal all joints, fastener penetrations and other breaks in vapor barrier with 3 inch wide strips of the same facing materials with factory applied vapor barrier adhesive, or 3 inch wide strips of white glass fabric embedded between two coats of vapor barrier mastic, Childers CP-30 or approved equal.
- E. Cold Duct (Below Ambient Temperature):
 - 1. Application Requirements: Insulate the following cold duct:
 - a. Outdoor air intake duct between air entrance and fan inlet or HVAC unit inlet.
 - b. HVAC supply duct between fan discharge, or HVAC unit discharge, and room terminal outlet.
 - 1) Insulate neck, backside, and bells of supply diffusers.
 - c. HVAC return duct between room terminal inlet and return fan inlet, or HVAC unit inlet.
 - d. HVAC plenums and unit housings not pre-insulated at factory or lined.
 - e. Exhaust duct work within the building non air-conditioned spaces.
 - 2. Insulate each duct system specified above with one of the following types and thicknesses of insulation:
 - a. Rigid Fiberglass: 2" thick, 3.0 PCF density, for both supply and exhaust round ducts exposed outdoor locations, or spaces without ceilings. Round duct insulation shall be E. O. Wood Rigid wrap® for all round ducts in areas without ceiling.
 - b. Flexible Fiberglass: 2" thick, 1.0 PCF density, minimum R-5 with foil faced continuous vapor barrier. This application is limited to concealed indoor locations only.
 - c. Foamglass: two (2) layers of 1" thick insulation blocks or 2" thick Armstrong Type II Armaflex flexible elastomeric closed cell sheet insulation or approved equal. (For outdoors locations).
 - 3. Ductwork exposed to view, any other exposed indoor locations, indoor non-conditioned spaces, or spaces without ceilings, installed in the mechanical rooms, AHU rooms and installed outdoors shall be finished above the insulation with canvas ALL SERVICE jacket of UL listed fabric of 8 oz. per square yard. Canvas joints and laps shall be glued and sealed with vapor seal mastic such as Foster 30-30 vapor barrier. Only outdoor ducts and insulated exhaust ductwork installed in the non-conditioned area shall be covered with 0.02" thick smooth aluminum rolled jacket. utilizing longitudinal "zee" closures.
 - 4. Exhaust ductwork within the air-conditioned spaces do not require to be insulated. Exhaust duct on roof exposed to the outside weather do not require to be insulated.

3.04 INSTALLATION

- A. Install materials in accordance with manufacturer's instructions.
- B. Insulated ductwork conveying air below ambient temperature:
 - 1. Provide insulation with vapor barrier jackets.
 - 2. Finish with tape and vapor barrier jacket.
 - 3. Continue insulation through walls, sleeves, hangers, and other duct penetrations.
 - 4. Insulate entire system including fittings, joints, flanges, fire dampers, flexible connections, and expansion joints.
- C. Insulated ductwork conveying air above ambient temperature:
 - 5. Provide with or without standard vapor barrier jacket.
 - 6. Insulate fittings and joints. Where service access is required, bevel and seal ends of insulation.

- D. For ductwork exposed in mechanical equipment rooms or in finished spaces, finish with aluminum jacket.
- E. For exterior applications, provide insulation with vapor barrier jacket. Cover with caulked aluminum jacket with seams located on bottom side of horizontal duct section.
- F. External Duct Insulation Application:
 - 1. Secure insulation with vapor barrier with wires and seal jacket joints with vapor barrier adhesive to match jacket.
 - 2. Secure insulation without vapor barrier with staples, tape, or wires.
 - 3. Install without sag on underside of ductwork. Use adhesive or mechanical fasteners where necessary to prevent sagging. Lift ductwork off trapeze hangers and insert spacers.
 - 4. Seal vapor barrier penetrations by mechanical fasteners with vapor barrier adhesive.
 - 5. Stop and point insulation around access doors and damper operators to allow operation without disturbing wrapping.
- G. Duct and Plenum Liner Application:
 - 1. Adhere insulation with adhesive for 100 percent coverage.
 - 2. Secure insulation with mechanical liner fasteners. Refer to SMACNA Standards for spacing.
 - 3. Seal and smooth joints.
 - 4. Seal liner surface penetrations with adhesive.
 - 5. Duct dimensions indicated are net inside dimensions required for air flow. Increase duct size to allow for insulation thickness.

All piping, equipment, ductwork, all plenums including metal and masonry construction, fans, etc., shall be insulated as indicated on the Drawings, as specified herein, and as required for a complete system. In each case, the insulation shall be equal to that specified and materials applied and finished as described in these Specifications.

All insulation shall be applied by mechanics skilled in this particular work and regularly engaged in such occupation. All insulation shall be applied in strict accordance with these Specifications and with factory printed recommendations on items not herein mentioned. Unsightly, inadequate, or sloppy work will not be acceptable, and all such work shall be removed and replaced as many times as necessary to achieve an acceptable installation.

All insulation, jacket, adhesives, mastics, sealers, etc., utilized in the fabrication of these systems shall meet NFPA for fire resistant ratings (maximum of 25 flame spread and 50 smoke developed ratings) and shall be approved by the insulation manufacturer for guaranteed performances when incorporated into their insulation system, unless a specific product is specified for a specific application, and is stated as an exception to this requirement. Certificates to this effect shall be submitted along with Contractor's submittal data for this section of the Specifications. No material may be used that, when tested by the ASTM E84-89 test method, is found to melt, drip or delaminate to such a degree that the continuity of the flame front is destroyed, thereby resulting in an artificially low flame spread rating.

All surfaces to be insulated shall be clean and dry before applying the insulation. All sections of molded pipe covering shall be firmly butted together. Where an insulation covering is applied, it shall lap the adjoining section of insulation by at least three inches (3"). Where insulation terminates, it shall be neatly beveled and finished. No insulation shall be applied until the pipe, duct, etc., have

been pressure tested and found tight. Piping, flexible connections, flanges, valves, strainers, and unions shall be covered unless specifically noted otherwise. Flexible connections on duct shall not be covered. All materials used shall be fire retardant or nonflammable.

Where vapor barriers are required, the vapor barrier shall be on the outside. Extreme care shall be taken that the vapor barrier is unbroken. Joints, etc., shall all be sealed. Where insulation with a vapor barrier terminates, it shall be sealed off with the vapor barrier being continuous to the surface being insulated. Ends shall not be left raw.

Extreme care shall be taken in covering high and medium pressure (high and medium pressure ductwork shall be all ductwork between the fan discharge and all mixing boxes) ductwork to insure the duct is not pierced with sheet metal screws or other fasteners. All high and medium pressure ducts in these specifications are classified as high velocity ductwork.

Where specified, aluminum bands shall be used on piping insulation. The bands shall be applied three (3) to a section of pipe. Fittings, valves, etc., shall have bands on each side.

Where canvas finish is specified, use Arabol lagging adhesive to prevent mildew in securing canvas. Do not use wheat paste. In addition, cover all canvas insulation with a fire retardant coating.

For purpose of definition in this Specification: "concealed" areas are those areas which cannot be seen by the building occupants, and "exposed" areas are all areas which are exposed to view by the building occupants, including under counter and inside cabinet areas, plus all mechanical rooms.

The handling and installation of all insulation materials shall be performed in strict accordance with the manufacturer's recommendations.

3.05 SCHEDULE

Piping	Type	Pipe Size	Insulation Thickness
Chilled Water (Exterior) Provide Stainless steel Jacket	A	1.5" & Smaller	1.5"
		2" & Larger	2"
Condensate Drain Lines (Interior Exposed)	B	All Sizes	1"
Heating Hot Water (Interior Exposed) Provide Aluminum Jacket	A	All Sizes	2"
Heating Hot Water (Interior Concealed)	A	1.5" & Smaller	1.5"
		2" & Larger	2"
Heating Hot Water (Exterior) Provide Stainless steel Jacket	A	1.5" & Smaller	1.5"
		3" & Larger	2"
Refrigerant Suction Piping	B	2" & Smaller	1-1/2"
Chilled Water (Interior Concealed)	A	1.5" & Smaller	1"
		2" & Larger	2"
Chilled Water (Interior Exposed) Provide Aluminum Jacket	A	1.5" & Smaller	1-1/2"
		2" & Larger	2"
Indoor ductwork Insulation Concealed Spaces	C	All sizes	2" & 1.5 lbs density
Indoor ductwork Insulation Non-concealed Spaces/ All areas without ceilings. Provide Aluminum Jacket	D	All sizes	2" & 3.0 lbs density
Outdoor Ductwork Insulation Provide Stainless steel Jacket	E	All sizes	two (2) layers of 1" thick

END OF SECTION

230923 – DIRECT DIGITAL CONTROL SYSTEMS FOR HVAC

PART 1 - GENERAL

1.00 SECTION INCLUDES

- A. Description
- B. Approved Control System Contractors and Manufacturers
- C. Quality Assurance
- D. Codes and Standards
- E. System Performance
- F. Submittals
- G. Warranty
- H. Ownership and licensing of Engineering and Operating Software

1.01 DESCRIPTION

- A. General: The control system shall consist of a high-speed, peer-to-peer, BACnet Testing Labs listed network of DDC controllers, all of the same family and manufacturer, residing and communicating on a BACnet IP (Internet Protocol) network. All operator workstation/server software shall also be BTL listed at time of bidding. The system software shall combine engineering and user functionality into a singular instance interface, (no dissimilar manufacturers), be server based and accessible via the owner's network portal to the internet.
- B. Users will interface with the system network via dashboard style multi-tasking dynamic color graphics. Access and manipulation of the system must be available via ALL of the following media and devices: current versions of Windows, Android and Apple OS devices operating in workstation, tablet or smartphone device platforms.
- C. The dashboard style package interface shall be of the same manufacturer as the controller manufacturer and have pre-built dashboard "widgets" as well as support custom dashboard widget development, as well as audit log, alarm management, trending graphics, remote access, set point adjustment, schedule changes, calendar changes, point overrides over the Owner's WAN and the Internet.
- D. The system shall incorporate all owner-defined, specified herein collected data as well as derived virtual data, (examples: building environmental, weather, utility, attendance and comparison data) and represent the information in a non-text, graphic form such as charts, graphs and other standard representations that various financial and operational personnel can utilize.
- E. Each mechanical system, building floor plan, control device, and energy meter will be depicted by point-and-click real-time dynamic graphics as well as standard information tree format. The owner shall be presented with a minimum of 8 standard widgets, (SEE SECTION 2.3, Paragraph F), for use in their system as listed herein.

- F. The owner shall provide at minimum for the first two years a connection to the Internet via high-speed cable modem, ADSL, ISDN, T1 or through the facility ISP. The owner shall be responsible for paying for all Internet access fees and connection charges.
- G. Advanced lighting control software shall also be included and shall support daylight harvesting, scene lighting and central switching strategies.

1.02 APPROVED CONTROL SYSTEM CONTRACTORS AND MANUFACTURERS

- A. Delta Controls by Travis Brothers.

1.03 QUALITY ASSURANCE

- A. Contractor/Manufacturer Qualifications
 1. NO SUBCONTRACTORS ALLOWED. All devices, wiring, conduit, terminations, etc, to be provided and installed by a factory trained person or persons, employed directly by Travis Brothers.
 2. All products used in this installation shall be new, currently under manufacture, and shall be applied in standard off the shelf products. This installation shall not be used as a test site for any new products unless explicitly approved by the Owner in writing. Spare parts shall be available for at least 5 years after completion of this contract.

1.04 CODES AND STANDARDS

All work, materials, and equipment shall comply with the rules and regulations of all codes and ordinances of the local, state, and federal authorities. Such codes, when more restrictive, shall take precedence over these plans and specifications. As a minimum, the installation shall comply with the current editions in effect 30 days prior to receipt of bids of the following codes:

1. National Electric Code (NEC)
2. Uniform Building Code (UBC)
3. Section 608, Shutoff for Smoke Control
4. Section 403.3, Smoke Detection Group B Office Buildings and Group R, Division 1 Occupancies
5. Section 710.5, Wiring in Plenums
6. Section 713.10, Smoke Dampers
7. Section 1106 Refrigeration Machinery Rooms
8. Section 1107, Refrigeration Machinery Room Ventilation
9. Section 1108, Refrigeration Machinery Room Equipment and Controls
10. Section 1120, Detection and Alarm Systems
11. Uniform Mechanical Code (UMC)
12. ASHRAE 135-2001
13. FCC Regulation, Part 15- Governing Frequency Electromagnetic Interference
14. Underwriters Laboratories UL916

1.05 SYSTEM PERFORMANCE

- A. Performance Standards. The system shall conform to the following:
1. Graphic Display. The system shall be dashboard based, and also capable of displaying a graphic with 20 dynamic points/objects with all current data within 10 seconds.
 2. Graphic Refresh. The system shall update a graphic with 20 dynamic points/objects with all current data within 8 seconds
 3. Object Command. The maximum time between the command of a binary object by the operator and the reaction by the device shall be less than 2 seconds. Analog objects should start to adjust within 2 seconds
 4. Object Scan. All changes of state and change of analog values will be transmitted over the high-speed Ethernet network such that any data used or displayed at a controller or workstation will have been current within the previous 2 seconds
 5. Alarm Response Time. The maximum time from when an object goes into alarm to when it is annunciated at the workstation shall not exceed 45 seconds
 6. Program Execution Frequency. Custom and standard applications shall be capable of running as often as once every 1 second. The Contractor shall be responsible for selecting execution times consistent with the mechanical process under control
 7. Performance. Programmable controllers shall be able to execute DDC PID control loops at a frequency of at least once per second. The controller shall scan and update the process value and output generated by this calculation at this same frequency
 8. Multiple Alarm Annunciation. All workstations on the network must receive alarms within 5 seconds of each other
 9. Reporting Accuracy. The system shall report all values with an end-to-end accuracy as listed or better than those listed in Table 1
 10. Energy Reporting. The operating software shall have as standard, dashboard widgets which can be selected by the operator to create individual interface points as well as multitrend graphics as standard.
 11. Stability of Control. Control loops shall maintain measured variable at setpoint within the tolerances listed in Table 2

B. TABLE 1: Reporting Accuracy

Measured Variable	Reported Accuracy
Space Temperature	$\pm 0.5^{\circ}\text{C}$ [$\pm 1^{\circ}\text{F}$]
Ducted Air	$\pm 0.5^{\circ}\text{C}$ [$\pm 1^{\circ}\text{F}$]
Outside Air	$\pm 1.0^{\circ}\text{C}$ [$\pm 2^{\circ}\text{F}$]
Dewpoint	$\pm 1.5^{\circ}\text{C}$ [$\pm 3^{\circ}\text{F}$]
Water Temperature	$\pm 0.5^{\circ}\text{C}$ [$\pm 1^{\circ}\text{F}$]
Delta-T	$\pm 0.15^{\circ}\text{C}$ [$\pm 0.25^{\circ}\text{F}$]
Relative Humidity	$\pm 5\%$ RH
Water Flow	$\pm 5\%$ of full scale
Airflow (terminal)	$\pm 10\%$ of full scale (<i>see Note 1</i>)
Airflow (measuring stations)	$\pm 5\%$ of full scale
Air Pressure (ducts)	± 25 Pa [± 0.1 "W.G.]
Air Pressure (space)	± 3 Pa [± 0.01 "W.G.]
Water Pressure	$\pm 2\%$ of full scale (<i>see Note 2</i>)
Electrical (A, V, W, Power factor)	5% of reading (<i>see Note 3</i>)
Carbon Monoxide (CO)	$\pm 5\%$ of reading

Measured Variable	Reported Accuracy
Carbon Dioxide (CO ₂)	±50 ppm
Note 1: 10%-100% of scale	
Note 2: For both absolute and differential	
Note 3: Not including utility-supplied	

C. TABLE 2: Control Stability and Accuracy

Controlled Variable	Control Accuracy	Range of Medium
Air Pressure	±50 Pa [±0.2" w.g.] ±3 Pa [±0.01" w.g.]	0-1.5 kPa [0-6" w.g.] -25 to 25 Pa [-0.1 to 0.1" w.g.]
Airflow	±10% of full scale	
Temperature	±0.5°C [±1.0°F]	
Humidity	±5% RH	
Fluid Pressure	±10 kPa [±1.5 psi]	0-1 kPa [1-150 psi]
“ “ differential	±250 Pa [±1.0" w.g.]	0-12.5 kPa [0-50" w.g.]

1.06 SUBMITTALS

A. Product Data and Shop Drawings: Contractor shall provide shop drawings or other submittals on all hardware, software, and installation to be provided. No work may begin on any segment of this project until submittals have been reviewed and approved for conformity with the design intent. Six copies are required. All drawings shall be done in DXF format and provided on magnetic/optical disk and as full-size drawings. When manufacturer's cut sheets apply to a product series rather than a specific product, the data specifically applicable to the project shall be highlighted or clearly indicated by other means. Each submitted piece of literature and drawings shall clearly reference the specification and/or drawing that the submittal is to cover. General catalogs shall not be accepted as cut sheets to fulfill submittal requirements. Submittals shall be provided within 12 weeks of contract award. Submittals shall include:

1. Direct Digital Control System Hardware
 - a. A complete bill of materials of equipment to be used shall be listed indicating quantity, manufacturer, model number, and other relevant technical data.
 - b. Manufacturer's description and technical data, such as performance curves, product specification sheets, and installation/maintenance instructions for the items listed below and other relevant items not listed below:
 1. Direct Digital Controller (controller panels)
 2. Transducers/Transmitters
 3. Sensors (including accuracy data)

4. Actuators
5. Valves
6. Relays/Switches
7. Control Panels
8. Power Supply
9. Batteries
10. Operator Workstation Equipment
11. Wiring
 - a. Wiring diagrams and layouts for each control panel. Show all termination numbers
 - b. Schematic diagrams for all field sensors and controllers. Provide floor plans of all sensor locations and control hardware
2. Central System Hardware and Software
 - c. A complete bill of material of equipment used indicating quantity, manufacturer, model number, and other relevant technical data.
 - d. Manufacturer's description and technical data, such as product specification sheets and installation/maintenance instructions for the items listed below and other relevant items not listed below:
 1. Central Processing Unit
 2. Monitors
 3. Printers
 4. Keyboard
 5. Power Supply
 6. Battery Backup
 7. Interface Equipment Between CPU and Control Panels
 8. Operating System Software
 9. Operator Workstation Software
 10. Color Graphic Software
 11. Third-party Software
 - e. A schematic diagram for all control wiring, communication wiring and power wiring shall be provided. Provide a schematic drawing of the central system installation. Label all cables and ports with computer manufacturers' model numbers, function and data link protocol(s). Show all interface wiring to the control system
 - f. Provide detailed riser diagrams of wiring between central control unit, operator workstation(s), routers, gateways and all control panels
 - g. Examples of the color graphic dashboard screens shall be provided. Provide 3 screen shots from 5 existing projects representing various For each screen, provide a conceptual layout of pictures and data, and show or explain which other screens can be directly accessed.
3. Controlled Systems:
 - a. A schematic diagram of each controlled system. The schematics shall have all control points/objects labeled and with point/object names shown or listed. The schematics shall graphically show the location of all control elements in the system
 - b. A schematic wiring diagram for each controlled system. Each schematic shall have all elements labeled. Where a control element is the same as that shown on the control system schematic, it shall be labeled with the same name. All terminals shall be labeled
 - c. An instrumentation list for each controlled system. Each element of the controlled system shall be listed in table format. The table shall show element name, type of device, manufacturer, model number, and product data sheet number

- d. A mounting, wiring, and routing plan view drawing. The drawing shall be done in 1/4" scale. The design shall take into account HVAC, electrical and other systems' design and elevation requirements. The drawing shall show the specific location of all concrete pads and bases and any special wall bracing for panels to accommodate this work
 - e. A complete description of the operation of the control system, including sequences of operation. The description shall include and reference a schematic diagram of the controlled system
 - f. A point/object list for each system controller including inputs and outputs (I/O), point/object number, the controlled device associated with the I/O point/object, and the location of the I/O device. Software flag points/objects, alarm points/objects, etc
- 4. Quantities of items submitted shall be reviewed, but are the responsibility of the Contractor
 - 5. A description of the proposed process along with all report formats and checklists to be used in Part 3: "Control System Demonstration and Acceptance."
 - 6. A BACnet Protocol Implementation Conformance Statement (PICS) for each type of controller and Operator Workstation included in the submittal. PICS to include for each product, as a minimum, a list of BACnet functional groups supported, BACnet services supported, BACnet data link options available and BACnet objects provided
- B. Schedules:
- 1. Within one month of contract award, provide a schedule of the work indicating the following:
 - a. Intended sequence of work items
 - b. Start dates of individual work items.
 - c. Duration of individual work items
 - d. Planned delivery dates for major material and equipment, and expected lead times
 - e. Milestones indicating possible restraints on work by other trades or situations
 - 2. Provide monthly written status reports indicating work completed, revisions to expected delivery dates, etc. An updated project schedule shall be included.
- C. Project Record Documents: Upon completion of installation, submit three copies of record (as-built) documents. The documents shall be submitted for approval prior to final completion and shall include:
- 1. Project Record Drawings. These shall be as-built versions of the submittal shop drawings. One set of magnetic media including DXF drawing files also shall be provided
 - 2. Testing and Commissioning Reports and Checklists. Completed versions of all reports and checklists, along with all trend logs, used to meet the requirements of Part 3: "Control System Demonstration and Acceptance."
 - 3. Certification of the pressure test required in Part 3: "Control Air Tubing."
 - 4. Operation and Maintenance (O & M) Manual. This shall include as-built versions of the submittal product data. In addition to the information required for submittals, the O & M manual shall include:
 - a. Names, addresses, and 24-hour telephone numbers of Contractors installing equipment, and the control systems and service representatives of each
 - b. Operators Manual with procedures for operating the control systems, including logging on/off, alarm handling, producing point/object reports, trending data, overriding computer control, and changing setpoints and other variables
 - c. One set of Programming Manuals with a description of the programming language (including syntax), statement descriptions (including algorithms and calculations used),

- point/object database creation and modification, program creation and modification, and use of the editor
 - d. Engineering, Installation, and Maintenance Manual(s) that explain how to design and install new points/objects, panels, and other hardware; preventive maintenance and calibration procedures; how to debug hardware problems; and how to repair or replace hardware
 - e. A listing and documentation of all custom software created using the programming language, including the setpoints, tuning parameters, and object database. One set of magnetic/optical media containing files of the software and database also shall be provided
 - f. One set of magnetic/optical media containing files of all color graphic screens created for the project
 - g. A list of recommended spare parts with part numbers and suppliers
 - h. Complete original issue documentation, installation, and maintenance information for all third-party hardware provided, including computer equipment and sensors
 - i. Complete original issue diskettes for all software provided, including operating systems, programming language, operator workstation software, and graphics software
 - j. Licenses, guarantee, and warranty documents for all equipment and systems
 - k. Recommended preventive maintenance procedures for all system components, including a schedule of tasks (inspection, cleaning, calibration, etc.), time between tasks, and task descriptions
- D. Training Manuals: The Contractor shall provide a course outline and training manuals for all training classes at least six weeks prior to the first class. The Owner may modify any or all of the training course outline and training materials to meet the needs of the Owner. Review and approval by the Owner shall be completed at least three weeks prior to the first class.
- E. Instructions for Development of Widgets
1. The submittal package shall include a factory generated, written instruction manual defining the process of building additional widgets. The manual shall be sufficiently detailed that a qualified employee of the owner should be able to generate new widgets.

1.07 WARRANTY

- A. Warrant all work as follows:
1. Labor and materials for the control system specified shall be warranted free from defects for a period of 12 months after final completion and acceptance. Control system failures during the warranty period shall be adjusted, repaired, or replaced at no additional cost or reduction in service to the Owner. The Contractor shall respond to the Owner's request for warranty service within 24 hours during normal business hours.
 2. All work shall have a single warranty date, even when the Owner has received beneficial use due to an early system start-up. If the work specified is split into multiple contracts or a multi-phase contract, then each contract or phase shall have a separate warranty start date and period
 3. At the end of the final start-up, testing, and commissioning phase, if equipment and systems are operating satisfactorily to the Owner, the Owner shall sign certificates certifying that the control system's operation has been tested and accepted in accordance with the terms of this specification. The date of acceptance shall be the start of warranty.
 4. Operator workstation software, project-specific software, graphic software, database software, and firmware updates which resolve known software deficiencies as identified by the Contractor shall be provided at no charge during the warranty period. Any upgrades or

functional enhancements associated with the above mentioned items also can be provided during the warranty period for an additional charge to the Owner by purchasing an in-warranty technical support agreement from the Contractor. Written authorization by the Owner must, however, be granted prior to the installation of any of the above-mentioned items.

5. Exception: The Contractor shall not be required to warrant reused devices, except for those that have been rebuilt and/or repaired. The Contractor shall warrant all installation labor and materials, however, and shall demonstrate that all reused devices are in operable condition at the time of Owner's acceptance.

1.08 OWNERSHIP OF PROPRIETARY MATERIAL

- A. All project-developed software and documentation shall become the property of the Owner. These include, but are not limited to:
 1. Project graphic images
 2. Record drawings
 3. Project database
 4. Project-specific application programming code
 5. All documentation

PART 2 –PRODUCTS

2.00 SECTION INCLUDES

- A. Materials
- B. Communication
- C. Operator Workstation and Dashboard Widgets
- D. Controller Software
- E. Building Controllers
- F. Advanced Application Controllers
- G. Application Specific Controllers
- H. Input/ Output Interface
- I. Power Supplies and Line Filtering
- J. Auxiliary Control Devices
- K. Wiring and Raceways
- L. Fiber Optic Cable System

2.01 MATERIALS

- A. All products used in this project installation shall be new, currently under manufacture, and shall be applied in similar installations for a minimum of two years. This installation shall not be used as a test site for any new products unless explicitly approved by the Owner's Representative in writing. Spare parts shall be available for at least five years after completion of this contract.

2.02 COMMUNICATION

- A. All control products provided for this project shall comprise a BACnet internetwork. Communication involving control components (i.e., all types of controllers and Operator Workstations) shall conform to ANSI/ASHRAE Standard 135-2001, BACnet.
- B. Each BACnet device shall operate on the BACnet Data Link/Physical layer protocol specified for that device as defined in this section.
- C. The Contractor shall provide all communication media, connectors, repeaters, bridges, hubs, switches, and routers necessary for the internetwork.
- D. All controllers shall have a communication port for connections with the Operator Workstations using the BACnet Data Link/ Physical layer protocol.
- E. Communication services over the internetwork shall result in operator interface and value passing that is transparent to the internetwork architecture as follows:
 - 1. Connection of an Operator Workstation device to any one controller on the internetwork will allow the operator to interface with all other controllers as if that interface were directly connected to the other controllers. Data, status information, reports, system software, custom programs, etc., for all controllers shall be available for viewing and editing from any one controller on the internetwork.
 - 2. All database values (e.g., objects, software variables, custom program variables) of any one controller shall be readable by any other controller on the internetwork. This value passing shall be automatically performed by a controller when a reference to an object name not located in that controller is entered into the controller's database. An operator/installer shall not be required to set up any communication services to perform internetwork value passing.
- F. The time clocks in all applicable controllers shall be automatically synchronized daily. An operator change to the time clock in any controller shall be automatically broadcast to all controllers on the network.
- G. The network shall have the following minimum capacity for future expansion:
 - 1. Each Building Controller shall have routing capacity for 99 controllers.
 - 2. The Building Controller network shall have capacity for 1000 Building Controllers.
 - 3. The system shall have an overall capacity for 12,500 Building Controller, Advanced Application Controller, and Application Specific Controller input/output objects.

2.03 OPERATOR WORKSTATION

- A. Operator Workstation. Existing servers and workstations shall be utilized and remain active on the system. Each of these workstations and or servers shall be able to access all information in the system. These workstations shall reside on the same Ethernet protocol network as the Building Controllers.
- B. Workstation information access shall use the BACnet protocol. Communication shall use the ISO 8802-3 (Ethernet) Data Link/ Physical layer protocol.

Data Sharing	Alarm & Event	Scheduling	Trending	Device Mgmt.	Network Mgmt
DS-RP-A,B	AE-N-A	SCHED-A	T-V-A	DM-DDB-A,B	NM-CE-A

Data Sharing	Alarm & Event	Scheduling	Trending	Device Mgmt.	Network Mgmt
DS-RPM-A,B	AE-N-I-B	SCHED-I-B	T-VMT-A	DM-DOB-A,B	NM-CEB
DS-WP-A,B	AE-N-E-B	SCHED-E-B	T-VMT-I-B	DM-DCC-A,B	
DS-WPM-A,B	AE-ACK-A,B	SCH-VM-A	T-VMT-E-B	DM-PT-A,B	
DS-COV-A,B	AE-ASUM-A,B	SCH-AVM-A	T-ATR-A	DM-TM-B	
DS-COVU-A,B	AE-ESUM-A,B	SCH-WS-A	T-ATR-B	DM-TS-A	
DS-V-A	AE-INFO-A,B	SCH-WS-I-B	T-A-A	DM-ATS-A	
DS-AV-A	AE-VN-A			DM-MTS-A	
DS-M-A	AE-AVN-A			DM-UTC-A,B	
DS-AM-A	AE-VM-A			DM-RD-A	
	AE-AVM-A			DM-BR-A	
	AE-AS-A			DM-LM-A,B	
				DM-OCD-A,B	
				DM-ANM-A	
				DM-ADM-A	

C. System Software

1. Operating System. Furnish a concurrent multi-tasking operating system. The operating system also shall support the use of other common software applications that operate under Microsoft Windows. Examples include Microsoft Excel, Microsoft Word, and Microsoft Access. Acceptable operating systems are Windows7, Windows 8 and Windows 2008 Server.
2. System Graphics. The operator workstation software shall be a graphical user interface (GUI). The system shall allow display of up to 10 dynamic and animated graphic screens at once for comparison and monitoring of system status. Provide a method for the operator to easily move between graphic displays and change the size and location of graphic displays on the screen. The system graphics shall be able to be modified while on-line. An operator with the proper password level shall be able to add, delete, or change dynamic objects on a graphic. Dynamic objects shall include analog and binary values, dynamic

text, static text, and animation files. Graphics shall have the ability to show animation by shifting image files based on the status of the object.

3. Custom Graphics. Custom graphic files shall be created with the use of a graphics generation package furnished with the system. The graphics generation package shall be a graphically based system that uses the mouse to create and modify graphics. The graphics generation package also shall provide the capability of capturing or converting graphics from other programs such as Visio or AutoCAD
 4. Graphics Library. Furnish a complete library of standard HVAC equipment graphics such as chillers, boilers, air handlers, terminals, fan coils, and unit ventilators. This library also shall include standard symbols for other equipment including fans, pumps, coils, valves, piping, dampers, and ductwork. The library shall be furnished in a file format compatible with the graphics generation package program. Graphics shall be created by drag-and-drop selection of graphic symbols and drag-and-link with BACnet objects with dynamic and interactive display fields.
 5. Multilingual. Software shall be supported in the following languages English, Spanish, French, German, and Chinese.
 6. Web Services. Furnish a web services portal to support BACnet Web Services as per ASHRAE BACnet/WS 135-2012am. Provide for data connections to mobile applications and third party business solutions.
- D. System Applications. Each workstation shall provide operator interface and off line storage of system information. Provide the following applications at each workstation:
1. System Database Save and Restore. Each workstation shall store on the hard disk a copy of the current database of each Building Controller. This database shall be updated whenever an operator initiates a save command.
 2. Manual Database Save and Restore. A system operator with the proper password clearance shall be able to save the database from any system panel. The operator shall be able to clear a panel database via the network and may initiate a download of a specified database to any panel in the system from the network.
 3. System Configuration. The workstation software shall provide a method of configuring the system. This shall allow for future system changes or additions by users under proper password protection.
 4. On-Line Help. Provide a context-sensitive, on-line help system to assist the operator in operating and editing the system. On- line help shall be available for all applications and shall provide the relevant data for that particular screen. Additional help information shall be available through the use of hypertext.
 5. Security. Each operator shall be required to log on to the system with a user name and password in order to view, edit, add, or delete data. System security shall be selectable for each operator. The system supervisor shall have the ability to set passwords and security levels for all other operators. Each operator password shall be able to restrict the functions accessible to viewing and/or changing each system application. System shall support LDAP to allow central control over user security status, restriction and/ or deletion of users.
 6. System Diagnostics. The system shall automatically monitor the operation of all workstations, printers, modems, network connections, building management panels, and controllers.
 7. Alarm Processing. Any object in the system shall be configurable to alarm in and out of normal state. The operator shall be able to configure the alarm limits, alarm limit differentials, states, and reactions for each object in the system.

8. Alarm Messages. Alarm messages shall use the English language descriptor for the object in alarm, in such a way that the operator will be able to recognize the source, location, and nature of the alarm without relying upon acronyms or other mnemonics.
 9. Alarm Reactions. The operator shall be able to determine (by object) what if any actions are to be taken during an alarm. Actions shall include logging, printing, starting programs, displaying messages, dialing out to remote stations, paging, providing audible annunciation.
 10. Trend Logs. The operator shall be able to define a custom trend log for any data object in the system. This definition shall include change-of-value digital, change-of-value analog, time interval, start time, and stop time. Trend data shall be sampled and stored on the Building Controller panel, and be archivable on a central data archiving machine(s). Provide a standard SQL connector to make the trend log data accessible for use in spreadsheets and standard database programs.
 11. Alarm and Event Log. The operator shall be able to view all system alarms and change of states from any location in the system. Events shall be listed chronologically. An operator with the proper security level may acknowledge and clear alarms.
 12. Object and Property Status and Control. Provide a method for the operator to view, and edit if applicable, the status of any object and property in the system. The status shall be available by menu, on graphics, or through custom programs.
 13. Clock Synchronization. The real-time clocks in all building control panels and workstations shall be using the BACnet Time Synchronization service. The system also shall be able to automatically synchronize all system clocks daily from any operator-designated device in the system. The system shall automatically adjust for daylight savings and standard time, if applicable.
 14. Timeline Analysis. Provide a graphical timeline tool that will display system events in chronological order. It shall be possible for the operator to display who logged into the system and when they logged in or out. These shall also allow the operator to add any other system event (like a temperature alarm) to the same timeline to see the chronological order of events, alarms, commands and system edits. Track all programming changes including which operator made them and when.
- E. Workstation Applications Editors. Each PC workstation shall support editing of all system applications. Provide editors for each application at the PC workstation. The applications shall be downloaded and executed at one or more of the controller panels.
1. Controller. Provide a full-screen editor for each type of application that shall allow the operator to view and change the configuration, name, control parameters, and setpoints for all controllers.
 2. Scheduling. An editor for the scheduling application shall be provided at each workstation. Provide a method of selecting the desired schedule and month. This shall consist of a monthly calendar for each schedule. Exception schedules and holidays shall be shown clearly on the calendar. Provide a method for allowing several related objects to follow a schedule. The start and stop times for each object shall be adjustable from this master schedule.
 3. Custom Application Programming. Provide the tools to create, modify, and debug custom application programming. The operator shall be able to create, edit, and download custom programs at the same time that all other system applications are operating. The system shall be fully operable while custom routines are edited, compiled, and downloaded. The programming language shall have the following features:

- a. The language shall be English language oriented, be based on the syntax of BASIC, FORTRAN, C, or PASCAL, and allow for free-form programming (i.e., not column-oriented or "fill in the blanks").
- b. A full-screen character editor/programming environment shall be provided. The editor shall be cursor/mouse-driven and allow the user to insert, add, modify, and delete custom programming code. It also shall incorporate word processing features such as cut/paste and find/replace.
- c. The programming language shall allow independently executing program modules to be developed. Each module shall be able to independently enable and disable other modules.
- d. The editor/programming environment shall have a debugging/simulation capability that allows the user to step through the program and observe any intermediate values and/or results. The debugger also shall provide error messages for syntax and execution errors.
- e. The programming language shall support conditional statements (IF/THEN/ELSE/ELSE-IF) using compound Boolean (AND, OR, and NOT) and/or relations (EQUAL, LESS THAN, GREATER THAN, NOT EQUAL) comparisons.
- f. The programming language shall support floating-point arithmetic using the following operators: +, -, /, x, square root, and x-to-the-y-power. The following mathematical functions also shall be provided: natural log, log, trigonometric functions (sine, cosine, etc.), absolute value, and minimum/maximum value from a list of values.
- g. The programming language shall have predefined variables that represent time of day, day of the week, month of the year, and the date. Other predefined variables shall provide elapsed time in seconds, minutes, hours, and days. These elapsed time variables shall be able to be reset by the language so that interval-timing functions can be stopped and started within a program. Values from all of the above variables shall be readable by the language so that they can be used in a program for such purposes as IF/THEN comparisons, calculations, etc.
- h. The language shall be able to read the values of the variables and use them in programming statement logic, comparisons, and calculations.
- i. The programs shall support online changes with the ability to read real time values without exiting the program. Sample programs and syntax help functions shall be resident in the program.

F. Widgets

1. Furnish ten graphical user interface screen widgets for use in the dashboard with the following content if applicable:
 - a. Energy consumption comparison pie-chart (in color) showing total energy in MMBTU by building.
 - b. Energy consumption comparison pie-chart (in color) showing total energy in BTU by meter.
 - c. Multitrend template for comparing up to 5 trend points on the same graph
 - d. Load profile line chart showing the current month's electrical demand in kW versus the same month last year.
 - e. Map showing the physical location of each building in the system along with a pop-up of the number of current alarms at each building.
 - f. A dynamic point schedule for each mechanical system that shows all input and output points in a table format. Changes in object names made by the system operator (like "DAT" changing to "Supply Air Temperature") must be automatically updated in the point list without operator entries.
 - g. An alarm summary view that includes all alarms from priority one thru eight.

- h. Energy alerts for all major mechanical equipment including, chillers, boilers, towers, AHU's over 15,000 CFM or RTU's over 15,000 CFM.
2. In addition to the above, software must include a custom widget development component that can be used by the owner to develop additional widgets without purchase of additional software.

2.04 CONTROLLER SOFTWARE

- A. Furnish the following applications software for building and energy management. All software applications shall reside and operate in the system controllers. Editing of applications shall occur at the operator workstation
- B. System Security
 1. User access shall be secured using individual security passwords and user names.
 2. Passwords shall restrict the user to the objects, applications, and system functions as assigned by the system manager.
 3. User Log On/Log Off attempts shall be recorded.
- C. Scheduling. Provide the capability to schedule each object or group of objects in the system. Each schedule shall consist of the following:

Provide an event scheduling system that allows the operator to specify a single event, multiple day event and/or recurring events. The event schedule specifies both the on/off times and the date in a calendar planning format similar to Microsoft Outlook®.

Calendar Schedules. Provide the capability for the operator to define up to 99 special schedules. These schedules may be placed on the scheduling calendar and will be repeated each year. The operator shall be able to define the length of each holiday period.
- D. Alarm Reporting. The operator shall be able to determine the action to be taken in the event of an alarm. Alarms shall be routed to the appropriate workstations based on time and other conditions.
- E. Remote Communication. The system shall have the ability to communicate out of the system top the internet in the event of an alarm using BACnet Point-To-Point attributes. Messaging capability shall include both text messaging and email service.
- F. Maintenance Management. The system shall monitor equipment status and generate maintenance messages based upon user-designated run-time, starts, and/or calendar date limits.
- G. Sequencing. Provide application software to properly sequence the start and stop of chillers, boilers, and pumps to minimize energy usage in the facility.
- H. PID Control. A PID (proportional-integral-derivative) algorithm with direct or reverse action and anti-windup shall be supplied. The algorithm shall calculate a time-varying analog value that is used to position an output or stage a series of outputs. The controlled variable, setpoint, and PID gains shall be user-selectable.
- I. Staggered Start. This application shall prevent all controlled equipment from simultaneously restarting after a power outage.
- J. Energy Calculations. Provide software to allow instantaneous power (e.g., kW) or flow rates (e.g., L/s [GPM]) to be accumulated and converted to energy usage data. Provide an algorithm that calculates a sliding-window kW demand value.
- K. Anti-Short Cycling. All binary output objects shall be protected from short cycling. This feature shall allow minimum on-time and off-time to be selected.

- L. On/Off Control with Differential. Provide an algorithm that allows a binary output to be cycled based on a controlled variable and setpoint. The algorithm shall be direct-acting or reverse-acting, and incorporate an adjustable differential.
- M. Run-time Totalization. Provide software to totalize run-times for all binary input objects. A high run-time alarm shall be assigned, if required, by the operator.

2.05 BUILDING CONTROLLERS

- A. General. Provide an adequate number of BACnet® Building Controllers to achieve the performance specified in the Part 1 Article on “System Performance.” Each of these panels shall meet the following requirements. Additionally, provide Building Controllers where shown on the drawings.
 1. The Energy Management and Control System shall be comprised of one or more independent, standalone, microprocessor-based Building Controllers to manage the global strategies described in the System Software section.
 2. The Building Controller shall have sufficient memory to support its operating system, database, and programming requirements.
 3. Data shall be shared between networked Building Controllers.
 4. The operating system of the Building Controller shall manage the input and output communication signals to allow distributed controllers to share real and virtual object information, and allow central monitoring and alarms.
 5. Controllers that perform scheduling shall have a battery or super-cap backed up real-time clock.
 6. The Building Controller shall support the following BACnet Interoperability Building Blocks (BIBBs):

Data Sharing	Alarm & Event	Scheduling	Trending	Device & Network Mgmt.
DS-RP-A,B	AE-N-A	SCH-I-B	T-VM-I-B	DM-DDB-A,B
DS-RPM-A,B	AE-N-I-B	SCH-E-B	T-VM-E-B	DM-DOB-A,B
DS-WP-A,B	AE-N-E-B		T-ATR-B	DM-DCC-B
DS-WPM-B	AE-ACK-B			DM-TS-A,B
DS-COVU-A,B	AE-ASUM-B			DM-UTC-A,B
	AE-ESUM-B			DM-ATS-A
				DM-RD-B
	AE-INFO-B			DM-BR-B
				DM-R-B
				DM-OCD-B
				NM-CE-A

B. Communication

1. Each Building Controller shall support direct Ethernet or a communications card. The Building Controller shall be connected to the BACnet network using the ISO 8802-3 (Ethernet) Data Link/ Physical layer protocol, or BACnet IP (Annex J).
2. Each Building Controller with a communications card shall perform BACnet routing if connected to a network of Custom Application and Application Specific Controllers.
3. The controller shall provide a service communication port using BACnet Data Link/ Physical layer protocol P-T-P for connection to a hand-held workstation/ and/or modem.
4. The Building Controller secondary communication network shall support BACnet MS/TP.

C. Environment. Controller hardware shall be suitable for the anticipated ambient conditions.

1. Controllers used outdoors and/or in wet ambient conditions shall be mounted within waterproof enclosures, and shall be rated for operation at 0°C to 40°C [32°F to 100°F] and 10 to 90% RH.
2. Controllers used in conditioned space shall be mounted in dust proof enclosures, and shall be rated for operation at 0°C to 50°C [32°F to 120°F].

D. Building Controllers shall be fully peer to peer.

E. Serviceability. Provide diagnostic LEDs for power, communication, and processor. All wiring connections shall be made to field- removable, modular terminal strips — or to a termination card connected by a ribbon cable.

F. Memory. The Building Controller shall have as a minimum standard SRAM of 256 KB, standard DRAM of 1MB and standard non-volatile 1 MB of flash memory in lieu of EPROM. Memory shall be user extendible through RAM chip sockets and SIMMs for future memory expansion.

G. Immunity to power and noise. Controller shall be able to operate at 90% to 110% of nominal voltage rating and shall perform an orderly shutdown below 80% nominal voltage. The Building Controller shall maintain all database information including BIOS and programming information in the event of a power loss for at least 72 hours. Operation shall be protected against electrical noise of 5 to 120 Hz and from keyed radios up to 5 W at 1 m [3 ft].

H. Inputs/Outputs.

1. Inputs. Controller input/output board shall support dry contact, 0-5 VDC and 0-10 VDC-voltage, 4-20 mA- current and thermistor-resistive signal types on an individual basis for connecting any status or sensing device. Analog resolution shall be minimum 10-bit A to D.
2. Outputs. Controller input/output board shall support plug-and-play I/O modules or built in HAO modules configured with manual-auto-off override switch, potentiometer and input channel for feedback status or an unrelated analog or digital input. Output supported shall be 0-10 VDC. All HAO's shall be supervised.
3. Diagnostics. Controller input board shall have variable intensity LEDs providing input status indication. Outputs shall have variable intensity LEDs indicating the output voltage with Color indication of HAO's status when present.
4. Bump-less Transfer. On analog outputs with override switches, provide a Hand-Auto-Off switch either built-in or external to the board that allows for manual positioning of the output, then transferring the output to automatic without any "bump" in the output voltage (don't go through off before transferring from manual to auto).

2.06 ADVANCED APPLICATION CONTROLLERS

A. General. Provide an adequate number of BACnet®Advanced Application Controllers to achieve the performance specified in the Part 1 Article on "System Performance." Each of these panels shall meet the following requirements.

1. The Advanced Application Controller shall have sufficient memory to support its operating system, database, and programming requirements.
2. Advanced Application Controllers shall be fully peer to peer.
3. The operating system of the Controller shall manage the input and output communication signals to allow distributed controllers to share real and virtual object information, and allow central monitoring and alarms.
4. All equipment that requires scheduling shall be scheduled in that equipments controller.
5. Both firmware and controller database shall be loadable over the network.
6. Advanced Application Controllers shall support the following BACnet Interoperability Building Blocks (BIBBs):

Data Sharing	Alarm & Event	Scheduling	Trending	Device & Network Mgmt.
DS-RP-A,B	AE-N-I-B	SCH-I-B	T-VM-I-B	DM-DDB-A,B
DS-RPM-B	AE-N-E-B	SCH-E-B	T-VM-E-B	DM-DOB-A,B
DS-WP-A,B	AE-ACK-B		T-ATR-B	DM-DCC-B
DS-WPM-B	AE-ASUM-B			DM-TS-B
DS-COV-A,B	AE-ESUM-B			DM-RD-B
	AE-INFO-B			DM-BR-B
				DM-R-B
				DM-OCD-B

B. Communication

1. Each Advanced Application Controller shall reside on a BACnet network using the MS/TP or Ethernet Data Link/ Physical layer protocol.

2. The controller shall provide a service communication port using BACnet Data Link/Physical layer protocol for connection to portable operator's workstation and allow access to the entire network.
- C. Environment. Controller hardware shall be suitable for the anticipated ambient conditions.
 1. Controllers used outdoors and/or in wet ambient conditions shall be mounted within waterproof enclosures, and shall be rated for operation at 0°C to 40°C [32°F to 100°F].
 2. Controllers used in conditioned space shall be mounted in dust proof enclosures, and shall be rated for operation at 0°C to 50°C [32°F to 120°F].
- D. Serviceability. Provide diagnostic LEDs for power, communication, and processor. All wiring connections shall be made to field-removable, modular terminal strips — or to a termination card connected by a ribbon cable.
- E. Memory. The Advanced Application Controller shall utilize non-volatile FLASH memory to maintain its operating system and backup all operator entered changes to setpoints, schedules, and commands.
- F. Immunity to power and noise. Controller shall be able to operate at 90% to 110% of nominal voltage rating and shall perform an orderly shutdown below 80% nominal voltage. Operation shall be protected against electrical noise of 5 to 120 Hz and from keyed radios up to 5 W at 1 m [3 ft].

2.07 APPLICATION SPECIFIC CONTROLLERS

- A. General. Provide BACnet® Application Specific Controllers (ASCs) as required to execute the sequence of operations. ASC's are microprocessor-based DDC controllers which through hardware or firmware design are able to control a wide variety of equipment. They shall be fully user-configurable.
 1. Each ASC shall be capable of standalone operation and shall continue to provide control functions without being connected to the network.
 2. Each ASC will contain sufficient I/O capacity to control the target system.
 3. Both firmware and controller database shall be loadable over the network
 4. ASC's shall come with an integrated housing to allow for easy mounting and protection of the circuit board. Only wiring terminals shall be exposed.
 5. Application Specific Controllers shall support the following BACnet Interoperability Building Blocks (BIBBs):

Data Sharing	Alarm & Event	Scheduling	Trending	Device & Network Mgmt.
DS-RP-B				DM-DDB-B
DS-RPM-B				DM-DOB-B
DS-WP-B				DM-DCC-B
DS-COV-B				DM-TS-B
				DM-RD-B

B. Communication

1. The controller shall reside on a BACnet network using the MS/TP or Ethernet Data Link/ Physical layer protocol or BACnet® over ZigBee protocol.
2. Each controller shall have a BACnet Data Link/ Physical layer compatible connection for a laptop computer or a portable operator's tool. This connection shall be extended to a space temperature sensor port where shown and allow access to the entire network.

C. Environment. The hardware shall be suitable for the anticipated ambient conditions.

1. Controllers used outdoors and/or in wet ambient conditions shall be mounted within waterproof enclosures, and shall be rated for operation at -40°C to 65°C [40°F to 150°F] and/or suitably installed in a heated or fan cooled enclosure
2. Controllers used in conditioned space shall be mounted in dust proof enclosures, and shall be rated for operation at 0°C to 50°C [32°F to 120°F].

D. Serviceability. Provide diagnostic LEDs for power, communication, and processor. All wiring connections shall be made to field-removable, modular terminal strips.

E. Memory. The Application Specific Controller shall use non-volatile memory and maintain all BIOS and programming information in the event of a power loss.

F. Immunity to power and noise. ASC shall be able to operate at 90% to 110% of nominal voltage rating and shall perform an orderly shutdown below 80%. Operation shall be protected against electrical noise of 5-120 Hz and from keyed radios up to 5 W at 1 m [3 ft].

G. Transformer. Power supply for the ASC must be rated at minimum of 125% of ASC power consumption, and shall be fused or current limiting type.

H. Input/Output. ASC shall support as a minimum, directly connected, a combination of analog outputs and binary outputs and universal software selectable analog or digital inputs. ASC inputs shall support 0-5 VDC-voltage, 4-20mA-current, thermistor-resistance and dry contacts. ASC outputs shall support 0-10 VDC-voltage, digital triac rated at 0.5 amps at 24 VAC

2.08 AUXILIARY CONTROL DEVICES

A. Motorized control dampers, unless otherwise specified elsewhere, shall be furnished by the controls contractor.

B. Electric damper/valve actuators.

1. The actuator shall have electronic overload or digital rotation sensing circuitry to prevent damage to the actuator throughout the rotation of the actuator.
2. Where shown, for power-failure/safety applications, an internal mechanical, spring-return mechanism shall be built into the actuator housing.
3. All non-spring-return actuators shall have an external manual gear release to allow manual positioning of the damper when the actuator is not powered. Spring-return actuators with more than 7 N•m [60 in-lb] torque capacity shall have a manual crank for this purpose.

C. Control valves.

1. Control valves shall be two-way or three-way type for two-position or modulating service as shown.
 2. Close-off (differential) Pressure Rating: Valve actuator and trim shall be furnished to provide the following minimum close-off pressure ratings:
 - a. Water Valves:
 1. Two-way: 150% of total system (pump) head.
 2. Three-way: 300% of pressure differential between ports A and B at design flow or 100% of total system (pump) head.
 - b. Steam Valves: 150% of operating (inlet) pressure.
 - c. Water Valves:
 1. Body and trim style and materials shall be per manufacturer's recommendations for design conditions and service shown, with equal percentage ports for modulating service.
 - d. Steam Valves:
 1. Body and trim materials shall be per manufacturer's recommendations for design conditions and service. Linear ports for modulating service.
- D. Binary Temperature Devices
1. Low-limit thermostats. Low-limit thermostats shall be vapor pressure type with an element 6 m [20 ft] minimum length. Element shall respond to the lowest temperature sensed by any 30 cm [1 ft] section. The low-limit thermostat shall be manual reset only and be supplied as DPST.
- E. Temperature sensors.
1. Temperature sensors shall be thermistors.
 2. Space sensors shall be equipped with the following:
 - a. Programmable buttons for setpoint adjustment and override
 - b. 3-value, 96-segment LCD display
 - c. Communication port connected to entire network
 3. Provide matched temperature sensors for differential temperature measurement.
- F. Humidity sensors.
1. Duct and room sensors shall have a sensing range of 20% to 80%.
 2. Duct sensors shall be provided with a sampling chamber.
 3. Outdoor air humidity sensors shall have a sensing range of 20% to 95% RH. They shall be suitable for ambient conditions of -40°C to 75°C [-40°F to 170°F].
 4. Humidity sensor's drift shall not exceed 3% of full scale per year.
- G. Flow switches.
1. Flow-proving switches shall be either paddle or differential pressure type, as shown.
- H. Pressure transducers
1. Transducer shall have linear output signal. Zero and span shall be field adjustable.
 2. Transducer sensing elements shall withstand continuous operating conditions of positive or negative pressure 50% greater than calibrated span without damage

3. Water pressure transducer shall have stainless steel diaphragm construction, proof pressure of 150 psi minimum. Transducer shall be complete with 1 - 5vdc or 4 to 20 mA output, required mounting brackets, and block and bleed valves.
 4. Water differential pressure transducer shall have stainless steel diaphragm construction, proof pressure of 150 psi minimum. Over-range limit (differential pressure) and maximum static pressure shall be 300 psi. Transducer shall be complete with 1 – 5vdc or 4 to 20 mA output, required mounting brackets, and five-valve manifold.
- I. Differential pressure type switches (air or water service) shall be UL listed, SPDT snap-acting, pilot duty rated (125 VA minimum), NEMA 1 enclosure, with scale range and differential suitable for intended application, or as shown.
 - J. Local control panels
 1. All indoor control cabinets shall be fully enclosed NEMA 1 construction with [hinged door], key-lock latch, removable sub-panels. A single key shall be common to all field panels and sub-panels
 2. Interconnections between internal and face-mounted devices pre-wired with color coded stranded conductors neatly installed in plastic troughs and/or tie wrapped. Control terminations for field connection shall be individually identified per control drawings
 3. Provide 120v receptacle at each local panel location.

2.09 WIRING AND RACEWAYS

- A. General: Provide copper wiring, plenum cable, and raceways as specified in the applicable sections of Division 16.
- B. All insulated wire to be copper conductors, UL labeled for 90C minimum service.

PART 3 - EXECUTION

3.00 SECTION INCLUDES

- A. Examination
- B. Protection
- C. Coordination
- D. General Workmanship
- E. Field Quality Control
- F. Existing Equipment
- G. Wiring
- H. Actuators
- I. Identification of Hardware and Wiring
- J. Controllers
- K. Programming
- L. Control System Checkout and Testing
- M. Control System Demonstration and Acceptance
- N. Cleaning
- O. Training
- P. Sequences of Operation

3.01 EXAMINATION

- A. The project plans shall be thoroughly examined for control device and equipment locations. Any discrepancies, conflicts, or omissions shall be reported to the Architect/Owner for resolution before rough-in work is started
- B. The Contractor shall inspect the site to verify that equipment may be installed as shown. Any discrepancies, conflicts, or omissions shall be reported to the Owner for resolution before rough-in work is started

3.02 PROTECTION

- A. The Contractor shall protect all work and material from damage by its work or employees, and shall be liable for all damage thus caused
- B. The Contractor shall be responsible for its work and equipment until finally inspected, tested, and accepted. The Contractor shall protect any material that is not immediately installed. The Contractor shall close all open ends of work with temporary covers or plugs during storage and construction to prevent entry of foreign objects

3.03 COORDINATION

- A. Site
 - 1. Where the mechanical work will be installed in close proximity to, or will interfere with work of other trades, the Contractor shall assist in working out space conditions to make a satisfactory adjustment. If the Contractor installs its work before coordinating with other trades, so as to cause any interference with work of other trades, the Contractor shall make the necessary changes in its work to correct the condition without extra charge
 - 2. Coordinate and schedule work with all other work in the same area, or with work, which is dependent upon other work, to facilitate mutual progress.
- B. Submittals. Refer to the "Submittals" Article in Part 1 of this specification for requirements
- C. Test and Balance
 - 1. The Contractor shall furnish all tools necessary to interface to the control system for test and balance purposes
 - 2. The Contractor shall provide training in the use of these tools. This training will be planned for a minimum of 4 hours
 - 3. In addition, the Contractor shall provide a qualified technician to assist in the test and balance process, until the first 20 terminal units are balanced.
 - 4. The tools used during the test and balance process will be returned at the completion of the testing and balancing
- D. Life Safety
 - 1. Duct smoke detectors required for air handler shutdown are supplied and installed under Division 16. The Division 16 Contractor shall interlock smoke detectors to air handlers for shutdown as described in Part 3: "Sequences of Operation".
 - 2. Smoke dampers and actuators required for duct smoke isolation are provided under another Division 15 Section
 - 3. Fire/smoke dampers and actuators required for fire rated walls are provided under another Division 15 Section. Control of these dampers shall be by Division 16.

- E. Coordination with controls specified in other sections or divisions. Other sections and/or divisions of this specification include controls and control devices that are to be part of or interfaced to the control system specified in this section. These controls shall be integrated into the system and coordinated by the Contractor as follows:
 - 1. All communication media and equipment shall be provided as specified in Part 2: “Communication” of this specification.
 - 2. Each supplier of controls product is responsible for the configuration, programming, start-up, and testing of that product to meet the sequences of operation described in this section.
 - 3. The Contractor shall coordinate and resolve any incompatibility issues that arise between the control products provided under this Section and those provided under other sections or divisions of this specification.

3.04 GENERAL WORKMANSHIP

- A. Install equipment, piping, and wiring/raceway parallel to building lines (i.e., horizontal, vertical, and parallel to walls) wherever possible.
- B. Provide sufficient slack and flexible connections to allow for vibration of piping and equipment
- C. Install all equipment in readily accessible locations as defined by Chapter 1, Article 100, and Part A of the National Electrical Code (NEC).
- D. All wiring shall be verified for its integrity to ensure continuity and freedom from shorts and grounds
- E. All equipment, installation, and wiring shall comply with acceptable industry specifications and standards for performance, reliability, and compatibility and be executed in strict adherence to local codes and standard practices.

3.05 FIELD QUALITY CONTROL

- A. All work, materials, and equipment shall comply with the rules and regulations of applicable local, state, and federal codes and ordinances as identified in Part 1 of this specification
- B. Contractor shall continually monitor the field installation for code compliance and quality of workmanship
- C. Contractor shall have work inspected by local and/or state/provincial authorities having jurisdiction over the work

3.06 EXISTING EQUIPMENT

- A. Wiring: The contractor may reuse any abandoned wires. The integrity of the wire and its proper application to the installation is the responsibility of the Contractor. The wire shall be properly identified and tested as per this specification. Unused or redundant wiring must be properly identified as such.
- B. Local Control Panels: The Contractor may re-use any existing local control panel to locate new equipment. All redundant equipment within these panels must be removed. Panel face cover must be patched to fill all holes caused by removal of unused equipment, or replaced with new.
- C. Unless otherwise directed, the Contractor is not responsible for the repairs or replacement of existing energy equipment and systems, valves, dampers, or actuators. Should the Contractor find existing equipment which requires maintenance, the Owner is to be notified immediately
- D. Temperature Sensor Wells: The Contractor may reuse any existing wells in piping for temperature sensors. These wells shall be modified as required for proper fit of new sensors

- E. Indicator Gauges: Where these devices remain and are not removed, they must be made operational and recalibrated to ensure reasonable accuracy. Maintain the operation of existing pneumatic transmitters and gauges.
- F. Room Thermostats: Deliver to Owner.
- G. Electronic Sensors and Transmitters: Unless specifically noted otherwise, remove and deliver to the Owner.
- H. Controllers and Auxiliary Electronic Devices: Deliver to the Owner.
- I. Pneumatic Controllers, Relays and Gauges: Deliver to Owner.
- J. Damper Actuators, Linkages and Appurtenances: Deliver to Owner.
- K. Control Valves: Replace with new.
- L. The mechanical system must remain in operation between the hours of 7 a.m. and 6 p.m., Monday through Friday. No modifications to the system shall cause the mechanical system to be shut down for more than 15 minutes or to fail to maintain space comfort condition during any such period. Perform cutover of controls that cannot meet these conditions outside of those hours
- M. The scheduling of fans through existing or temporary time-clocks or control system shall be maintained throughout the DDC system installation.
- N. Install control panels where shown
- O. Modify existing starter control circuits, if necessary, to provide Hand/Off/Auto control of each starter controlled.
- P. Patch holes and finish to match existing

3.07 WIRING

- A. All control and interlock wiring shall comply with national and local electrical codes and Division 16 of this specification. Where the requirements of this section differ with those in Division 16, the requirements of this section shall take precedence.
- B. All NEC Class 1 (line voltage) wiring shall be UL Listed in approved raceway per NEC and Division 16 requirement.
- C. All low-voltage wiring shall meet NEC Class 2 requirements. (Low-voltage power circuits shall be sub-fused when required to meet Class 2 current-limit.)

3.08 ACTUATORS

- A. Mount and link control damper actuators per manufacturer's instructions.
 - 1. To compress seals when spring-return actuators are used on normally closed dampers, power actuator to approximately 5° open position, manually close the damper, and then tighten the linkage
 - 2. Check operation of damper/actuator combination to confirm that actuator modulates damper smoothly throughout stroke to both open and closed positions.
 Provide all mounting hardware and linkages for actuator installation.
- B. Electric/Electronic
 - 1. Dampers: Actuators shall be direct-mounted on damper shaft or jackshaft unless shown as a linkage installation. For low-leakage dampers with seals, the actuator shall be mounted with a minimum 5° available for tightening the damper seals. Actuators shall be mounted following manufacturer's recommendations

2. Valves: Actuators shall be connected to valves with adapters approved by the actuator manufacturer. Actuators and adapters shall be mounted following the actuator manufacturer's recommendations.

3.09 IDENTIFICATION OF HARDWARE AND WIRING

- A. All wiring and cabling, including that within factory fabricated panels, shall be labeled at each end within 5 cm [2"] of termination with the DDC address or termination number.
- B. Permanently label or code each point/object of field terminal strips to show the instrument or item served.
- C. Identify control panels with minimum 1 cm [1/2"] letters on laminated plastic nameplates.
- D. Identify all other control components with permanent labels. All plug-in components shall be labeled such that removal of the component does not remove the label.
- E. Identify room sensors relating to terminal box or valves with nameplates.

3.10 CONTROLLERS

- A. Provide a separate controller for each AHU or other HVAC system.
- B. Building Controllers and Advanced Application Controllers shall be selected to provide a minimum of 15% spare I/O point/object capacity for each point/object type found at each location. If input /objects are not universal, 15% of each type is required. If outputs are not universal, 15% of each type is required. A minimum of one spare is required for each type of point/object used.
 1. Future use of spare capacity shall require providing the field device, field wiring, point/object database definition, and custom software. No additional controller boards or point/object modules shall be required to implement use of these spare points

3.11 PROGRAMMING

- A. Provide sufficient internal memory for the specified sequences of operation and trend logging. There shall be a minimum of 25% of available memory free for future use.
- B. Point/object Naming: System point/object names shall be modular in design, allowing easy operator interface without the use of a written point/object index. Object names shall be case-sensitive and clearly spell out the function of each object. Submit naming scheme to owner for prior approval. Do not use cryptic abbreviations. Valid examples are:
 1. AHU-1 Supply Air Temperature
 2. CH-1 Chilled Water Supply Temperature
 3. FC-1 Room Temperature
 4. VAV-103 Room Temperature Trend
- C. Software Programming
 1. Provide programming for the system and adhere to the sequences of operation provided. The Contractor also shall provide all other system programming necessary for the operation of the system, but not specified in this document. Imbed into the control program sufficient comment statements to clearly describe each section of the program. The comment statements shall reflect the language used in the sequences of operation. Use the appropriate technique based on the following programming types:
 - a. Text-based:
 1. Must provide actions for all possible situations
 2. Must be modular and structured

3. must be commented
 - b. Graphic-based
 1. must provide actions for all possible situations
 2. must be documented
 - c. Parameter-based
 1. must provide actions for all possible situations
 2. must be documented
- D. Operator Interface
1. Standard Graphics. Provide graphics for all mechanical systems and floor plans of the building. This includes each chilled water system, hot water system, chiller, boiler, air handler, and all terminal equipment. Point/object information on the graphic displays shall dynamically update. Show on each graphic all input and output points/objects for the system. Also show relevant calculated points/objects such as setpoints
 2. Show terminal equipment information on a “graphic” summary table. Provide dynamic information for each point/object
 3. The Contractor shall provide all the labor necessary to install, initialize, start up, and troubleshoot all Operator Workstation software and their functions as described in this section. This includes any operating system software, the Operator Workstation database, and any third-party software installation and integration required for successful operation of the operator interface

3.12 CONTROL SYSTEM CHECKOUT AND TESTING

- A. Start-up Testing: All testing listed in this article shall be performed by the Contractor and shall make up part of the necessary verification of an operating control system. This testing shall be completed before the Owner’s Representative is notified of the system demonstration.
1. The Contractor shall furnish all labor and test apparatus required to calibrate and prepare for service of all instruments, controls, and accessory equipment furnished under this specification
 2. Verify that all control wiring is properly connected and free of all shorts and ground faults. Verify that terminations are tight
 3. Enable the control systems and verify calibration of all input devices individually. Perform calibration procedures per manufacturers’ recommendations
 4. Verify that all binary output devices (relays, solenoid valves, two position actuators and control valves, magnetic starters, etc.) operate properly and that the normal positions are correct
 5. Verify that all analog output devices (I/Ps, actuators, etc.) are functional, that start and span are correct, and that direction and normal positions are correct. The Contractor shall check all control valves and automatic dampers to ensure proper action and closure. The Contractor shall make any necessary adjustments to valve stem and damper blade travel
 6. Verify that the system operation adheres to the Sequences of Operation. Simulate and observe all modes of operation by overriding and varying inputs and schedules. Tune all DDC loops and optimum Start/Stop routines.
 7. Alarms and Interlocks
 - a. Check each alarm separately by including an appropriate signal at a value that will trip the alarm
 - b. Interlocks shall be tripped using field contacts to check the logic, as well as to ensure that the fail-safe condition for all actuators is in the proper direction.

- c. Interlock actions shall be tested by simulating alarm conditions to check the initiating value of the variable and interlock action

3.13 CONTROL SYSTEM DEMONSTRATION AND ACCEPTANCE

A. Demonstration

1. Prior to acceptance, the control system shall undergo a series of performance tests to verify operation and compliance with this specification. These tests shall occur after the Contractor has completed the installation, started up the system, and performed its own tests
2. The tests described in this section are to be performed in addition to the tests that the Contractor performs as a necessary part of the installation, startup, and debugging process and as specified in the "Control System Checkout and Testing" Article in Part 3 of this specification. The Engineer will be present to observe and review these tests. The Engineer shall be notified at least 10 days in advance of the start of the testing procedures.
3. The demonstration process shall follow that approved in Part 1: "Submittals." The approved checklists and forms shall be completed for all systems as part of the demonstration
4. The Contractor shall provide at least two persons equipped with two way communication, and shall demonstrate actual field operation of each control and sensing point for all modes of operation including day, night, occupied, unoccupied, fire/smoke alarm, seasonal changeover, and power failure modes. The purpose is to demonstrate the calibration, response, and action of every point/object and system. Any test equipment required to prove the proper operation shall be provided by and operated by the Contractor.
5. As each control input and output is checked, a log shall be completed showing the date, technician's initials, and any corrective action taken or needed.
6. Demonstrate compliance with Part 1: "System Performance
7. Demonstrate compliance with Sequences of Operation through all modes of operation
8. Demonstrate complete operation of Operator Workstation
9. Additionally, the following items shall be demonstrated:
 - a. DDC Loop Response. The Contractor shall supply trend data output in a graphical form showing the step response of each DDC loop. The test shall show the loop's response to a change in setpoint, which represents a change of actuator position of at least 25% of its full range. The sampling rate of the trend shall be from 10 seconds to 3 minutes, depending on the speed of the loop. The trend data shall show for each sample the setpoint, actuator position, and controlled variable values. Any loop that yields unreasonably under-damped or over-damped control shall require further tuning by the Contractor.
 - b. Demand limiting. The Contractor shall supply a trend data output showing the action of the demand-limiting algorithm. The data shall document the action on a minute by minute basis over at least a 30-minute period. Included in the trend shall be building kW, demand limiting setpoint, and the status of shed-able equipment outputs.
 - c. Optimum Start. The Contractor shall supply a trend data output showing the capability of the algorithm. The hour by hour trends shall include the output status of all optimally started and stopped equipment, as well as temperature sensor inputs of affected areas
 - d. Interface to the building fire alarm system
 - e. Operational logs for each system that indicate all setpoints, operating points, valve positions, mode, and equipment status shall be submitted to the Architect/Engineer.

These logs shall cover three 48 hour periods and have a sample frequency of not more than 10 minutes. The logs shall be provided in both printed and disk formats.

- f. Any tests that fail to demonstrate the operation of the system shall be repeated at a later date. The Contractor shall be responsible for any necessary repairs or revisions to the hardware or software to successfully complete all tests.

B. Acceptance

1. All tests described in this specification shall have been performed to the satisfaction of both the Engineer and Owner prior to the acceptance of the control system as meeting the requirements of Completion. Any tests that cannot be performed due to circumstances beyond the control of the Contractor may be exempt from the Completion requirements if stated as such in writing by the Engineer. Such tests shall then be performed as part of the warranty.
2. The system shall not be accepted until all forms and checklists completed as part of the demonstration are submitted and approved as required in Part 1: "Submittals."

3.14 CLEANING

- A. The Contractor shall clean up all debris resulting from its activities daily. The Contractor shall remove all cartons, containers, crates, etc., under its control as soon as their contents have been removed. Waste shall be collected and placed in a designated location.
- B. At the completion of work in any area, the Contractor shall clean all of its work, equipment, etc., keeping it free from dust, dirt, and debris, etc.
- C. At the completion of work, all equipment furnished under this section shall be checked for paint damage, and any factory-finished paint that has been damaged shall be repaired to match the adjacent areas. Any cabinet or enclosure that has been deformed shall be replaced with new material and repainted to match the adjacent areas.

3.15 TRAINING

- A. General
 1. Provide a minimum of one onsite training class 8 hours in length during the construction period for personnel designated by the owner.
 2. Provide two additional training sessions at 6 and 12 months following building's turnover. Each session shall be 8 hrs in length and must be coordinated with the building Owner. Provide (3) additional (8) hour training sessions per year for the life of the system.
- B. Train the designated staff of Owner's Representative and Owner to enable Day-to-day Operators to:
 1. Proficiently operate the system.
 2. Understand control system architecture and configuration.
 3. Understand DDC system components.
 4. Understand system operation, including DDC system control and optimizing routines (algorithms).
 5. Operate the workstation and peripherals.
 6. Log on and off the system.
 7. Access graphics, point/object reports, and logs.
 8. Adjust and change system setpoints, time schedules, and holiday schedules.
 9. Recognize malfunctions of the system by observation of the printed copy and graphical visual signals.

10. Understand system drawings, and Operation and Maintenance manual.
 11. Understand the job layout and location of control components.
 12. Access data from DDC controllers and Application Specific Controllers (ASC's).
 13. Operate portable operator's terminals.
- C. Train the designated staff of Owner's Representative and Owner to enable Advanced Operators to:
1. Make and change graphics on the workstation
 2. Create, delete, and modify alarms, including annunciation and routing of these
 3. Create, delete, and modify point/object trend logs, and graph or print these
 4. Create, delete, and modify reports
 5. Add, remove, and modify system's physical points/objects
 6. Create, modify, and delete programming
 7. Add panels when required
 8. Add Operator Workstation stations
 9. Create, delete, and modify system displays — both graphical and otherwise
 10. Perform DDC system field checkout procedures
 11. Perform DDC controller unit operation and maintenance procedures
 12. Perform workstation and peripheral operation and maintenance procedures
 13. Perform DDC system diagnostic procedures
 14. Configure hardware including PC boards, switches, communication, and I/O points/objects
 15. Maintain, calibrate, troubleshoot, diagnose, and repair hardware
 16. Adjust, calibrate, and replace system components
- D. Train the designated staff of Owner's Representative and Owner to enable System Managers/Administrators to:
1. Maintain software and prepare backups
 2. Interface with job-specific, third-party operator software
 3. Add new users and understand password security procedures
- E. Provide course outline and materials as per "Submittals" Article in Part 1 of this specification. The instructor(s) shall provide one copy of training material per student.
- F. The instructor(s) shall be factory-trained instructors experienced in presenting this material.
- G. Classroom training shall be done using a network of working controller's representative of the installed hardware.

3.16 SEQUENCES OF OPERATION

SECTION 233100 - SHEET METAL DUCTWORK

PART 1 - GENERAL

1.01 WORK INCLUDED

- A. Low pressure duct.
- B. Duct pressure testing.

1.02 RELATED WORK

- A. Section 09900 - Painting: Weld priming, weather resistant, paint or coating.
- B. Section 15140 - Supports and Anchors: Sleeves.
- C. Section 15250 - Mechanical Insulation.
- D. Section 15910 - Duct Accessories.
- E. Section 15990 - Testing, Adjusting and Balancing.

1.03 REFERENCES

- A. ASHRAE - Handbook 1993 Fundamentals; Chapter 32 - Duct Design.
- B. ASHRAE - Handbook 1992 HVAC Systems and Equipment; Chapter 16 - Duct Construction.
- C. ASTM A 90 - Weight of Coating on Zinc-Coated (Galvanized) Iron or Steel Articles.
- D. ASTM A 525 - General Requirements for Steel Sheet, Zinc-Coated (Galvanized) by the Hot-Dip Process.
- E. ASTM A 527 - Steel Sheet, Zinc-Coated (Galvanized) by Hot-Dip Process, Lock Forming Quality.
- F. NFPA 90A - Installation of Air Conditioning and Ventilating Systems.
- G. NFPA 90B - Installation of Warm Air Heating and Air Conditioning Systems.
- H. SMACNA - Low Pressure Duct Construction Standards.
- I. UL 181 - Factory-Made Air Ducts and Connectors.
- J. ASTM A 167 - Stainless and Heat-Resisting Chromium-Nickel Steel Plate, Sheet, and Strip.
- K. NFPA 96 - Installation of Equipment for the Removal of Smoke and Grease-Laden Vapors from Commercial Cooling Equipment.

1.04 DEFINITIONS

- A. Duct sizes shown are net inside clear dimensions. Duct shall be externally insulated. Where offsets or transitions are required, the duct shall maintain the equivalent diameter based on hydraulic diameter and rectangular duct size for equal flow, velocity and pressure drop as calculated by Huebscher formulae #30 and/or 31 in ASHRAE Duct Design Fundamentals Handbook and Figure 5 Friction Chart for round duct.
- B. Low Pressure: Three pressure classifications: 1/2 inch WG positive or negative static pressure and velocities less than 2,000 fpm; 1 inch WG positive or negative static pressure and velocities less than 2,500 fpm, and 2 inch WG positive or negative static pressure and velocities less than 2,500 fpm. All duct shall be sealed as specified, independent of SMACNA pressure class.

1.05 SUBMITTALS

- A. Refer to other applicable sections for additional coordination drawings, duct shop drawings and product data and conform to provisions of Division 1.
- B. Indicate duct fittings, particulars such as gages, sizes, welds, and configuration prior to start of work.
- C. The Contract Documents are schematic in nature and are to be used only for design intent. The Contractor shall prepare coordination and sheet metal shop drawings, fully detailed and drawn to scale, indicating all architectural partitions, structural conditions, all plumbing pipe and light fixtures co-ordinations, and all offsets and transitions as required to permit the duct to fit in the space allocated and built and show all bottom of duct elevations. All duct revisions required as a result of the Contractor not preparing fully detailed shop drawings will be performed at no additional cost to the Owner.
- D. Sheet metal ductwork "shop" drawings shall be made after actual job measurements are obtained. Sheet metal ductwork drawings shall indicate the coordination of the Contractor with sprinkler piping and other mechanical and electrical services installed under Division 15 and 16. These "Shop Drawings" shall be submitted for review as specified in Section 15010. Ductwork joint, connection, ductwork "shop" drawing submittal. Details shall be indexed and index number shall appear on ductwork "shop drawing" at its point of use.

1.06 DELIVERY, STORAGE, AND HANDLING

- A. Deliver products to site under provisions of Division 1.
- B. Store and protect products under provisions of Division 1.
- C. Protect duct from contamination by dirt, dust or rain by covering openings; do not store duct in open on site.

PART 2 - PRODUCTS

2.01 ACCEPTABLE MANUFACTURERS

- A. Armco - "Zinc-Grip".
- B. Flex-master.
- C. Substitutions: Under provisions of Division 1.
- D. Sheet Metal Connectors, Inc
- E. McGill Airflow LLC

2.02 MATERIALS

- A. General: Non-combustible and conforming to requirements for Class 1 air duct materials, or UL 181.
- B. Steel Ducts: ASTM A525 galvanized steel sheet, lock-forming quality, having zinc coating of 1.25 oz per sq. ft. for each side in conformance with ASTM A90. Minimum gauge for all duct shall be 26 gauge (0.019").
- C. Flexible Round Ducts:
 - 1. Low pressure: Interlocking spiral wire of galvanized steel or aluminum construction with flexible trilaminate inner fabric rated to 6 inches WG positive and 1 inches WG negative for low pressure ducts, insulated with 1" thick fiberglass insulation and reinforced metalized outer vapor barrier; Flexmaster type 5-m insulated or equal, NFPA 90A and U.L. 181 class 1 listed;
- D. Stainless Steel Ducts: ASTM A167, Type 304 for all Lab Exhaust System.

- E. Fasteners: Rivets, bolts, or sheet metal screws.
- F. Sealant: Non-hardening, water resistant, fire resistive, compatible with mating materials; liquid used alone or with tape, or heavy mastic.
- G. Hanger Rod: Steel, galvanized; continuously threaded.

2.03 LOW PRESSURE DUCT

- A. Fabricate and support in accordance with SMACNA Low Pressure Duct Construction Standards and ASHRAE handbooks, except as indicated. Provide duct material, gages, reinforcing, and sealing for operating pressures indicated, except that all duct joints and longitudinal seams for all SMACNA classes of duct shall be sealed with U.L. Listed Hardcast DT-tape and sealant FTA-20.
- B. Size round ducts installed in place of rectangular ducts in accordance with ASHRAE table of equivalent rectangular and round ducts. No variation of duct configuration or sizes permitted except by approved shop drawings.
- C. Construct tees, offsets, and elbows with radius of not less than 1-1/2 times width of duct on centerline. Where not possible and where rectangular elbows are used, provide single thickness turning vanes for duct velocities up to 1500 fpm and for higher duct velocities, provide airfoil turning vanes.
- D. Increase duct sizes gradually, not exceeding 15 degrees divergence wherever possible. Divergence upstream of equipment shall not exceed 30 degrees; convergence downstream shall not exceed 45 degrees.
- E. Use crimp joints with bead for joining round duct sizes 6 inch smaller with crimp in direction of air flow.
- F. Use double nuts and lock washers on threaded rod supports.

PART 3 - EXECUTION

3.01 GENERAL INSTALLATION REQUIREMENTS

- A. Obtain manufacturer's inspection and acceptance of fabrication and installation of duct at beginning of installation.
- B. Provide openings in duct where required to accommodate thermometers and controllers. Provide pilot tube openings where required for testing of systems, complete with metal well and closure device to ensure against air leakage. Where openings are provided in insulated duct, install insulation material inside a metal ring.
- C. Locate ducts with sufficient space around equipment to allow normal operating and maintenance activities.
- D. Connect fan coil units to low pressure OA intake ducts with short length of flexible duct. Hold in place with corrosion resistant clamp or strap.
- E. Connect air distribution devices to low pressure ducts with 6 feet maximum, 4 feet minimum, length of flexible duct. Hold in place with corrosion resistant strap or clamp.
- F. During construction provide temporary closures of metal or taped polyethylene on open duct to prevent construction dust from entering duct system.
- G. The interior surface of all duct shall be smooth. No sheet metal parts, tabs, angles, or anything else may project into the ducts for any reason, except as specified to be so. All seams and joints shall be external.
- H. Where ducts pass through floors, provide structural angles for duct support. Where ducts pass through walls in exposed areas, install suitable sheet metal escutcheons.

- I. All angles shall be carried around all four sides of the duct or group of ducts. Angles shall overlap corners and be welded or riveted.
- J. All duct shall be fabricated in a manner to prevent the seams or joints being cut for the installation of air distribution devices.
- K. All rectangular duct located exposed on roof shall have top horizontal surface "crowned or sloped" to prevent water from ponding. Ref: Insulation for additional requirements.
- L. Provide all new round flex duct minimum length 6'-0", for extension use round sheet metal duct externally insulated with 1-1/2" thick, 1.5 p.c.f. Density fiberglass insulation with "F-S-K-L" (foil-skrim-kraft-laminate) vapor barrier.
- M. Provide round spin-in fittings with locking quadrant butterfly volume dampers for all round duct connections to rectangular ducts. Spin-in and flex duct shall be same size as air distribution device neck diameter. Secure flex duct to spin-in and air distribution device neck with stainless steel worm gear clamps and seal vapor barrier. Suspend flex duct from structure above; round and flexible duct shall be as detailed by SMACNA in section iii round, oval and flexible duct. Round duct seams shall be type RL-1 spiral seam or seam type RL-5 grooved seam flat pipe lock constructed in accordance with SMACNA figure 3-1; flexible duct supports shall be constructed and installed in accordance with SMACNA figures 3-9 and 3-10.
- N. Duct dimensions shown are net clear Internal Dimensions; allowance must be made for 1-1/2" thick external insulation as specified; all rectangular and round supply air, return air, outside air and exhaust air duct shall be galvanized sheet metal.
- O. Provide duct test wells at all locations required for testing, adjusting balancing, and temperature measuring.
- P. All duct shall be mounted tight to underside of structure and shall be top level with bottom and side transitions only, except that allowance shall be made for duct to be externally insulated, which shall be mounted 3" below structural beams and joists or other obstruction to allow installation of the external duct insulation. Some ducts may require the use of "ESS"-drive joints or flat seams to allow crossing of duct or installation of other equipment or piping. Raise existing duct where required to allow installation of other duct or equipment; use 45 degree radius elbows (center line radius = 1.5 times duct height) to offset.
- Q. Typical supply, return and exhaust duct shall be as detailed by SMACNA in Section II fittings and other construction. All 90 degree elbows shall be constructed in accordance with SMACNA figure 2-2, style RE-1 radius elbow (center line radius = 1.5 times duct height or width), space permitting or style RE-2 square throat with turning vanes (provide duct access panel up stream of turning vanes for cleaning purposes).
- R. Turning vanes shall be installed in accordance with figure 2.3; single wall type with trailing edge for duct velocities up to 1500 fpm and double wall turning vanes above 1500 fpm duct velocity.
- S. Parallel flow branches shall be constructed in accordance with figure 2-7. Rectangular duct branch connections shall be expanded 45 degree entry type and round branch duct connections shall be spin-in type in accordance with figure 2-8 and offsets and transitions shall be in accordance with figure 2-9.
- T. Duct access doors shall be constructed in accordance with figure 2-12 and shall have a frame type 3, position 3 hinge with a type 2 locking handle; single and multi-blade volume dampers shall be in accordance with figures 2-14 and 2-15 respectively and shall have operator extensions when provided on externally insulated ducts; air distribution device connections shall be in accordance with figure 2-16 and ceiling diffuser branch ducts shall be in accordance with figure 2-17.

- U. Rectangular duct connections at all air moving equipment shall be flexible neoprene fabric and installed in accordance with figure 2-19.
- V. Seal all non-welded duct joints of all SMACNA pressure classes with Hard-cast DT-cotton tape and duct sealer FTA-20 for indoor duct and duct sealer FTA-50 for exterior duct.

3.02 DUCT APPLICATION SCHEDULE

AIR SYSTEM

MATERIAL

Low Pressure Supply or return
 Return and Relief
 General Exhaust
 Outside Air Intake

Galvanized Steel
 Galvanized Steel
 Galvanized Steel
 Galvanized Steel

3.03 DUCT HANGERS AND SUPPORTS

- A. All duct shall be properly suspended or supported from the building structure. Hangers shall be galvanized steel straps or hot-dipped galvanized rod with threads pointed after installation. Strap hanger shall be attached to the bottom of the duct. The spacing, size and installation of hangers shall be in accordance with the recommendations of SMACNA, latest edition.
- B. All duct risers shall be supported by angles or channels secured to the sides of the ducts at each floor with sheet metal screws or rivets. The floor supports may also be secured to ducts by rods, angles or flat bar to the duct joint or reinforcing. Miscellaneous steel supports for duct risers shall be provided under this Division.

3.04 ADJUSTING AND CLEANING

- A. Clean duct system and force air at high velocity through duct to remove accumulated dust. To obtain sufficient air, clean half the system at a time. Protect equipment which may be harmed by excessive dirt with temporary filters, or bypass during cleaning.

END OF SECTION

This page was left blank intentionally

SECTION 233300 - AIR DUCT ACCESSORIES

PART 1 - GENERAL

1.01 RELATED DOCUMENTS

- A. Drawings and general provisions of the Contract, including General and Supplementary Conditions and Division 01 Specification Sections, apply to this Section.

1.02 SUMMARY

- A. Section Includes:
 - 1. Backdraft and pressure relief dampers.
 - 2. Barometric relief dampers.
 - 3. Manual volume dampers.
 - 4. Control dampers.
 - 5. Fire dampers.
 - 6. Duct-mounted access doors.
 - 7. Flexible connectors.
 - 8. Flexible ducts.
 - 9. Duct accessory hardware.

1.03 SUBMITTALS

- A. Product Data: For each type of product indicated.
 - 1. For duct silencers, include pressure drop and dynamic insertion loss data. Include breakout noise calculations for high transmission loss casings.
- B. Shop Drawings: For duct accessories. Include plans, elevations, sections, details and attachments to other work.
 - 1. Detail duct accessories fabrication and installation in ducts and other construction. Include dimensions, weights, loads, and required clearances; and method of field assembly into duct systems and other construction. Include the following:
 - a. Special fittings.
 - b. Manual volume damper installations.
 - c. Control damper installations.
 - d. Fire-damper, smoke-damper, combination fire- and smoke-damper, ceiling, and corridor damper installations, including sleeves; and duct-mounted access doors and remote damper operators.
 - e. Duct security bars.
- C. Coordination Drawings: Reflected ceiling plans, drawn to scale, on which ceiling-mounted access panels and access doors required for access to duct accessories are shown and coordinated with each other, using input from Installers of the items involved.
- D. Source quality-control reports.
- E. Operation and Maintenance Data: For air duct accessories to include in operation and maintenance manuals.

1.04 QUALITY ASSURANCE

- A. Comply with NFPA 90A, "Installation of Air Conditioning and Ventilating Systems," and with NFPA 90B, "Installation of Warm Air Heating and Air Conditioning Systems."
- B. Comply with AMCA 500-D testing for damper rating.

1.05 EXTRA MATERIALS

- A. Furnish extra materials that match products installed and that are packaged with protective covering for storage and identified with labels describing contents.
 - 1. Fusible Links: Furnish quantity equal to 10 percent of amount installed.

PART 2 - PRODUCTS

2.01 MATERIALS

- A. Comply with SMACNA's "HVAC Duct Construction Standards - Metal and Flexible" for acceptable materials, material thicknesses, and duct construction methods unless otherwise indicated. Sheet metal materials shall be free of pitting, seam marks, roller marks, stains, discolorations, and other imperfections.
- B. Galvanized Sheet Steel: Comply with ASTM A 653/A 653M.
 - 1. Galvanized Coating Designation: G90 (Z275).
 - 2. Exposed-Surface Finish: Mill phosphatized.
- C. Stainless-Steel Sheets: Comply with ASTM A 480/A 480M, Type 304, and having a No. 2 finish for concealed and exposed ducts.
- D. Aluminum Sheets: Comply with ASTM B 209 (ASTM B 209M), Alloy 3003, Temper H14; with mill finish for concealed ducts and standard, 1-side bright finish for exposed ducts.
- E. Extruded Aluminum: Comply with ASTM B 221 (ASTM B 221M), Alloy 6063, Temper T6.
- F. Reinforcement Shapes and Plates: Galvanized-steel reinforcement where installed on galvanized sheet metal ducts; compatible materials for aluminum and stainless-steel ducts.
- G. Tie Rods: Galvanized steel, 1/4-inch (6-mm) minimum diameter for lengths 36 inches (900 mm) or less; 3/8-inch (10-mm) minimum diameter for lengths longer than 36 inches (900 mm).

2.02 BACKDRAFT AND PRESSURE RELIEF DAMPERS

- A. Manufacturers: Subject to compliance with requirements, provide products by one of the following:
 - 1. Air Balance Inc.; a division of Mestek, Inc.
 - 2. American Warming and Ventilating; a division of Mestek, Inc.
 - 3. Cesco Products; a division of Mestek, Inc.
 - 4. Duro Dyne Inc.
 - 5. Greenheck Fan Corporation.
 - 6. Lloyd Industries, Inc.
 - 7. Nailor Industries Inc.
 - 8. NCA Manufacturing, Inc.
 - 9. Pottorff; a division of PCI Industries, Inc.
 - 10. Ruskin Company.
 - 11. SEMCO Incorporated.
 - 12. Vent Products Company, Inc.

- B. Description: Gravity balanced.
- C. Maximum Air Velocity: 2000 fpm.
- D. Maximum System Pressure: 2-inch wg.
- E. Frame: 0.063-inch- thick extruded aluminum with welded corners and mounting flange.
- F. Blades: Multiple single-piece blades, maximum 6-inch width, 0.025-inch- thick, roll-formed aluminum noncombustible with sealed edges.
- G. Blade Action: Parallel.
- H. Blade Seals: Neoprene, mechanically locked.
- I. Blade Axles:
 - 1. Material: Stainless steel.
 - 2. Diameter: 0.20 inch.
- J. Tie Bars and Brackets: Galvanized steel.
- K. Return Spring: Adjustable tension.
- L. Bearings: Synthetic pivot bushings.
- M. Accessories:
 - 1. Adjustment device to permit setting for varying differential static pressure.
 - 2. Counterweights and spring-assist kits for vertical airflow installations.
 - 3. Electric actuators.
 - 4. Chain pulls.
 - 5. Screen Mounting: Front mounted in sleeve.
 - a. Sleeve Thickness: 20-gage minimum.
 - b. Sleeve Length: 6 inches minimum.
 - 6. Screen Material: Aluminum.
 - 7. Screen Type: Bird.
 - 8. 90-degree stops.

2.03 BAROMETRIC RELIEF DAMPERS

- A. Manufacturers: Subject to compliance with requirements, provide products by one of the following:
 - 1. Air Balance Inc.; a division of Mestek, Inc.
 - 2. American Warming and Ventilating; a division of Mestek, Inc.
 - 3. Cesco Products; a division of Mestek, Inc.
 - 4. Duro Dyne Inc.
 - 5. Greenheck Fan Corporation.
 - 6. Lloyd Industries, Inc.
 - 7. Nailor Industries Inc.
 - 8. NCA Manufacturing, Inc.
 - 9. Pottorff; a division of PCI Industries, Inc.
 - 10. Ruskin Company.
 - 11. SEMCO Incorporated.
 - 12. Vent Products Company, Inc.

- B. Suitable for horizontal or vertical mounting.
- C. Maximum Air Velocity: 2000 fpm.
- D. Maximum System Pressure: 2-inch wg.
- E. Frame: 0.063-inch- (thick extruded aluminum], with welded corners and mounting flange.
- F. Blades:
 - 1. Multiple, 0.025-inch-thick, roll-formed aluminum.
 - 2. Maximum Width: 6 inches (150 mm).
 - 3. Action: Parallel.
 - 4. Balance: Gravity.
 - 5. Eccentrically pivoted.
- G. Blade Seals: Neoprene.
- H. Blade Axles: Nonferrous metal.
- I. Tie Bars and Brackets:
 - 1. Material: Aluminum
 - 2. Rattle free with 90-degree stop.
- J. Return Spring: Adjustable tension.
- K. Bearings: Synthetic.
- L. Accessories:
 - 1. Flange on intake.
 - 2. Adjustment device to permit setting for varying differential static pressures.

2.04 MANUAL VOLUME DAMPERS

- A. Standard, Steel, Manual Volume Dampers:
 - 1. Manufacturers: Subject to compliance with requirements, provide products by one of the following:
 - a. Air Balance Inc.; a division of Mestek, Inc.
 - b. American Warming and Ventilating; a division of Mestek, Inc.
 - c. Flexmaster U.S.A., Inc.
 - d. McGill AirFlow LLC.
 - e. METALAIRE, Inc.
 - f. Nailor Industries Inc.
 - g. Pottorff; a division of PCI Industries, Inc.
 - h. Ruskin Company.
 - i. Trox USA Inc.
 - j. Vent Products Company, Inc.
 - 2. Standard leakage rating, with linkage outside air stream.
 - 3. Suitable for horizontal or vertical applications.
 - 4. Frames:
 - a. Hat-shaped, galvanized channels, 0.064-inch minimum thickness.
 - b. Mitered and welded corners.
 - c. Flanges for attaching to walls and flangeless frames for installing in ducts.

5. Blades:
 - a. Multiple or single blade.
 - b. Parallel- or opposed-blade design.
 - c. Stiffen damper blades for stability.
 - d. Galvanized, 0.064 inch thick.
6. Blade Axles: Nonferrous metal.
7. Bearings:
 - a. Oil-impregnated bronze.
 - b. Dampers in ducts with pressure classes of 3-inch wg or less shall have axles full length of damper blades and bearings at both ends of operating shaft.
8. Tie Bars and Brackets: Galvanized steel.

2.05 FIRE DAMPERS

- A. Manufacturers: Subject to compliance with requirements, [provide products by one of the following:
 1. Air Balance Inc.; a division of Mestek, Inc.
 2. Arrow United Industries; a division of Mestek, Inc.
 3. Greenheck Fan Corporation.
 4. METALAIRE, Inc.
 5. Nailor Industries Inc.
 6. Pottorff; a division of PCI Industries, Inc.
 7. Ruskin Company.
 8. Ward Industries, Inc.; a division of Hart & Cooley, Inc.
- B. Type: Static; rated and labeled according to UL 555 by an NRTL.
- C. Closing rating in ducts up to 4-inch wg static pressure class and minimum 4000-fpm velocity.
- D. Fire Rating: 1-1/2 hours.
- E. Frame: Curtain type with blades outside air stream fabricated with roll-formed, 0.034-inch thick galvanized steel; with mitered and interlocking corners.
- F. Mounting Sleeve: Factory- or field-installed, galvanized sheet steel.
 1. Minimum Thickness: 0.052 or 0.138 inch thick, as indicated, and of length to suit application.
 2. Exception: Omit sleeve where damper-frame width permits direct attachment of perimeter mounting angles on each side of wall or floor; thickness of damper frame must comply with sleeve requirements.
- G. Mounting Orientation: Vertical or horizontal as indicated.
- H. Blades: Roll-formed, interlocking, 0.034-inch-thick, galvanized sheet steel. In place of interlocking blades, use full-length, 0.034-inch-thick, galvanized-steel blade connectors.
- I. Horizontal Dampers: Include blade lock and stainless-steel closure spring.
- J. Heat-Responsive Device: Replaceable, 165 deg F rated, fusible links.

2.06 DUCT-MOUNTED ACCESS DOORS

- A. Manufacturers: Subject to compliance with requirements, provide products by one of the following:

1. American Warming and Ventilating; a division of Mestek, Inc.
 2. Ductmate Industries, Inc.
 3. Flexmaster U.S.A., Inc.
 4. Greenheck Fan Corporation.
 5. McGill AirFlow LLC.
 6. Nailor Industries Inc.
 7. Pottorff; a division of PCI Industries, Inc.
 8. Ward Industries, Inc.; a division of Hart & Cooley, Inc.
- B. Duct-Mounted Access Doors: Fabricate access panels according to SMACNA's "HVAC Duct Construction Standards - Metal and Flexible"; Figures 2-10, "Duct Access Doors and Panels," and 2-11, "Access Panels - Round Duct."
1. Door:
 - a. Double wall, rectangular.
 - b. Galvanized sheet metal with insulation fill and thickness as indicated for duct pressure class.
 - c. Vision panel.
 - d. Hinges and Latches: 1-by-1-inch butt or piano hinge and cam latches.
 - e. Fabricate doors airtight and suitable for duct pressure class.
 2. Frame: Galvanized sheet steel, with bend-over tabs and foam gaskets.
 - a. Number of Hinges and Locks:
 - b. Access Doors Less Than 12 Inches Square: No hinges and two sash locks.
 - c. Access Doors up to 18 Inches Square: Two hinges and two sash locks.
 - d. Access Doors up to 24 by 48 Inches: Three hinges and two compression latches. Access Doors Larger Than 24 by 48 Inches: Four hinges and two compression latches with outside and inside handles.
- C. Pressure Relief Access Door:
1. Door and Frame Material: Galvanized sheet steel.
 2. Door: Double wall with insulation fill with metal thickness applicable for duct pressure class.
 3. Operation: Open outward for positive-pressure ducts and inward for negative-pressure ducts.
 4. Factory set at 10-inch wg.
 5. Doors close when pressures are within set-point range.
 6. Hinge: Continuous piano.
 7. Latches: Cam.
 8. Seal: Neoprene or foam rubber.
 9. Insulation Fill: 1-inch thick, fibrous-glass or polystyrene-foam board.

2.07 FLEXIBLE DUCTS

- A. Manufacturers: Subject to compliance with requirements, provide products by one of the following:
1. Flexmaster U.S.A., Inc.
 2. McGill AirFlow LLC.

3. Ward Industries, Inc.; a division of Hart & Cooley, Inc.
- B. Insulated, Flexible Duct: UL 181, Class 1, 2-ply vinyl film supported by helically wound, spring-steel wire; fibrous-glass insulation; [polyethylene] [aluminized] vapor-barrier film.
 1. Pressure Rating: 10-inch wg positive and 1.0-inch wg negative.
 2. Maximum Air Velocity: 4000 fpm.
 3. Temperature Range: Minus 10 to plus 160 deg F.
 4. Insulation R-value: Comply with ASHRAE/IESNA 90.1-2004.
- C. Insulated, Flexible Duct: UL 181, Class 1, multiple layers of aluminum laminate supported by helically wound, spring-steel wire; fibrous-glass insulation; aluminized vapor-barrier film.
 1. Pressure Rating: 10-inch wg positive and 1.0-inch wg negative.
 2. Maximum Air Velocity: 4000 fpm.
 3. Temperature Range: Minus 20 to plus 210 deg F.
 4. Insulation R-value: Comply with ASHRAE/IESNA 90.1-2004.
- D. Flexible Duct Connectors:
 1. Clamps: Stainless-steel band with cadmium-plated hex screw to tighten band with a worm-gear action in sizes 3 through 18 inches to suit duct size.
 2. Non-Clamp Connectors: Adhesive plus sheet metal screws.

2.08 DUCT ACCESSORY HARDWARE

- A. Instrument Test Holes: Cast iron or cast aluminum to suit duct material, including screw cap and gasket. Size to allow insertion of pitot tube and other testing instruments and of length to suit duct-insulation thickness.
- B. Adhesives: High strength, quick setting, neoprene based, waterproof, and resistant to gasoline and grease.

PART 3 - EXECUTION

3.01 INSTALLATION

- A. Install duct accessories according to applicable details in SMACNA's "HVAC Duct Construction Standards - Metal and Flexible" for metal ducts and in NAIMA AH116, "Fibrous Glass Duct Construction Standards," for fibrous-glass ducts.
- B. Install duct accessories of materials suited to duct materials; use galvanized-steel accessories in galvanized-steel and fibrous-glass ducts, stainless-steel accessories in stainless-steel ducts, and aluminum accessories in aluminum ducts.
- C. Install volume dampers at points on supply, return, and exhaust systems where branches extend from larger ducts. Where dampers are installed in ducts having duct liner, install dampers with hat channels of same depth as liner, and terminate liner with nosing at hat channel.
 1. Install steel volume dampers in steel ducts.
 2. Install aluminum volume dampers in aluminum ducts.
- D. Set dampers to fully open position before testing, adjusting, and balancing.
- E. Install test holes at fan inlets and outlets and elsewhere as indicated.
- F. Install fire dampers according to UL listing.
- G. Install duct access doors on sides of ducts to allow for inspecting, adjusting, and maintaining accessories and equipment at the following locations:

1. On both sides of duct coils.
 2. Upstream from duct filters.
 3. At outdoor-air intakes and mixed-air plenums.
 4. At drain pans and seals.
 5. Downstream from manual volume dampers, control dampers, backdraft dampers, and equipment.
 6. Adjacent to and close enough to fire or smoke dampers, to reset or reinstall fusible links. Access doors for access to fire or smoke dampers having fusible links shall be pressure relief access doors and shall be outward operation for access doors installed upstream from dampers and inward operation for access doors installed downstream from dampers.
 7. At each change in direction and at maximum 50-foot spacing.
 8. Upstream and downstream from turning vanes.
 9. Upstream or downstream from duct silencers.
 10. Control devices requiring inspection.
 11. Elsewhere as indicated.
- H. Install access doors with swing against duct static pressure.

3.02 FIELD QUALITY CONTROL

- A. Tests and Inspections:
1. Operate dampers to verify full range of movement.
 2. Inspect locations of access doors and verify that purpose of access door can be performed.
 3. Operate fire, smoke, and combination fire and smoke dampers to verify full range of movement and verify that proper heat-response device is installed.
 4. Inspect turning vanes for proper and secure installation.
 5. Operate remote damper operators to verify full range of movement of operator and damper.

END OF SECTION

SECTION 233419 - HVAC POWER VENTILATORS

PART 1 - GENERAL

1.01 SECTION INCLUDES

- A. Furnish and install roof and wall exhausters and cabinet and ceiling exhaust fans for mechanical systems.

1.02 RELATED SECTIONS

- A. Section 016600 – Product Storage and Handling Requirements.
- B. Section 016613 – Product Storage and Handling Requirements for Hazardous Materials.
- C. Section 016616 – Product Storage and Handling Requirements for Toxic Materials.
- D. Section 220526 – Hangers and Supports for Plumbing Piping and Equipment.
- E. Section 230526 – Hangers and Supports for HVAC Piping and Equipment.
- F. Section 220543 – Vibration and Seismic Control for Plumbing and Piping Equipment.
- G. Section 230543 – Vibration and Seismic Control for HVAC Piping and Equipment.
- H. Section 233100 – HVAC Ducts and Casings.
- I. Section 233416 – Centrifugal HVAC Fans.
- J. Section 230593 – Testing, Adjusting, and Balancing for HVAC.
- K. Section 230513 – Common Motor Requirements for HVAC.

1.03 REFERENCES

- A. AMCA 99 – Standards Handbook.
- B. AMCA 210 – Laboratory Methods of Testing Fans for Rating Purposes.
- C. AMCA 300 – Test Code for Sound Rating Air Moving Devices.
- D. AMCA 301 – Method of Publishing Sound Ratings for Air Moving Devices.
- E. SMACNA – Low Pressure Duct Construction Standard.

1.04 SUBMITTALS

- A. Include fan curves with specified operating point clearly plotted.
- B. Include sound power levels for both fan inlet and outlet at rated capacity.
- C. Indicate special coating when required.
- D. Provide operation and maintenance manual.
- E. Operation and Maintenance Data: For centrifugal fans to include in emergency, operation, and maintenance manuals.

1.05 QUALITY ASSURANCE

- A. Performance Ratings: Conform to AMCA 210 and bear the AMCA Certified Rating Seal.
- B. Sound Ratings: AMCA 301, tested to AMCA 300.
- C. Fabrication: Conform to AMCA 99.

PART 2 - PRODUCTS

2.01 MANUFACTURERS

- A. Greenheck.
- B. Cook.
- C. Twin City.
- D. Bayley.

2.02 ROOF EXHAUSTERS

- A. Centrifugal or Axial Fan Unit: Backward inclined or airfoil design, v-belt or direct driven, with spun aluminum housing, resilient mounted motor and drive assembly, 1/2-inch mesh, 16 gauge aluminum bird screen; square base to suit roof curb with continuous curb gaskets; secured to roof curb with cadmium plated or stainless steel bolts and screws, as indicated in Drawings.
- B. Roof Curb: 12 inch with continuously welded seams, built-in cant strip, 1 inch insulation and curb bottom, hinged curb adapter and factory installed door mailer strip. Where scheduled, provide interior baffle with acoustic insulation and increase curb height as required.
- C. Disconnect Switch: Factory wired, non-fusible, in housing for thermal overload protected motor.
- D. Backdraft Damper: Gravity activated, aluminum multiple blade construction, felt edged with nylon bearings.
- E. Sheaves: Cast-iron or steel, dynamically balanced, bored to fit shafts and keyed; adjustable pitch motor sheave selected so required rpm is obtained with sheaves set at mid position; and will not overload motor when adjusted to maximum pitch; fan shaft with self-aligning pre-lubricated ball bearings.
- F. Apply three coats of air dried Heresite coating both internal and external to all roof exhausters from corrosive areas.
- G. Motors: In total compliance with Section 230513.

2.03 UP-BLASTS EXHAUST FANS

- A. Centrifugal Fan Unit: Non-overloading backward inclined or airfoil design, v-belt driven, with spun aluminum housing, resilient mounted motor and drive assembly located out of airstream; square base to suit roof curb with continuous curb gaskets; secured with cadmium plated or stainless steel bolts and screws.
- B. Roof Curb: 12 inch high aluminum construction with continuous seams, built-in cant strip and factory installed mailer strip. Roof curb shall match fan and shall be supplied by fan manufacturer. Provide sloped roof curb as required for installed equipment to set level.
- C. Disconnect Switch: Factory wired, non-fusible, in housing for thermal overload protected motor.
- D. Grease Collector: Provide grease trough and collectors for kitchen hood fans.
- E. Sheaves: Cast-iron or steel, dynamically balanced, bored to fit shafts and keyed; adjustable pitch motor sheave selected so required rpm is obtained with sheaves set at mid position; and will not overload motor when adjusted to maximum pitch; fan shaft with self-aligning pre-lubricated ball bearings. Drive shall be designed for 165% of rated horsepower capabilities.
- F. Motors: In total compliance with Section 230513.

2.04 SOURCE QUALITY CONTROL

- A. The following tests must be conducted at the project site.
 - 1. Vibration test as described in Section 016600 – Product Storage and Handling Requirements, Section 016613 – Product Storage and Handling Requirements for Hazardous Materials, and Section 016616 – Product Storage and Handling Requirements for Toxic Materials.
- B. The following listed tests must be conducted at the manufacturer=s test facility.
 - 1. Vibration test as described in Section 230593 – Testing, Adjusting, and Balancing for HVAC.
 - 2. Sound test under AMCA Guidelines and Conditions. The sound power levels must not exceed those indicated on Drawings.

PART 3 - EXECUTION

3.01 INSTALLATION

- A. Install in accordance with manufacturer’s instructions.
- B. Secure roof exhausters with 1/2" x 2” S.S. lag screws roof curb.
- C. Install flexible ductwork connections when fan connects to ductwork.
- D. Provide al ventilating and exhaust fans with integral vibration isolation.
- E. Water test ventilators after installation.

3.02 PAINTING

- A. Duct installation and connection requirements are specified in other Division 23 Sections. Drawings indicate general arrangement of ducts and duct accessories. Make final duct connections with flexible connectors. Flexible connectors are specified in Division 23 Section "Air Duct Accessories."
- B. Install ducts adjacent to fans to allow service and maintenance.
- C. Install line-sized piping from scroll drain connection, with trap with seal equal to 1.5 times specified static pressure, to nearest floor drain.
- D. Ground equipment according to Division 26 Section "Grounding and Bonding for Electrical Systems."
- E. Connect wiring according to Division 26 Section "Low-Voltage Electrical Power Conductors and Cables."

3.03 FIELD QUALITY CONTROL

- A. Provide equipment with factory finish in accordance with the manufacturer’s standards. Touch scratches and marks from handling and installation with masking enamel to match manufacturer’s color.
- B. Where exhaust fans are required to have Heresite coating, have units factory finished with required number of coats prior to shipping to the job site.

END OF SECTION

SECTION 233600 - AIR TERMINAL UNITS

PART 1 - GENERAL

1.01 SECTION INCLUDES

- A. Furnish and install air terminal units of constant volume fan powered type for use in variable volume central systems, including:
 - 1. Fan powered terminal units.
 - 2. Variable volume regulators.
 - 3. Integral heating coils.
 - 4. Integral damper motor operators.
 - 5. Integral controls.
 - 6. Integral Silencer.

1.02 RELATED SECTIONS

- A. Section 230716 – HVAC Equipment Insulation.
- B. Section 232113 –Hydronic Piping.
- C. Section 233100 – HVAC Ducts and Casings.
- D. Section 233300 – Air Duct Accessories.
- E. Section 230993 –Direct-Digital Control System for HVAC.
- F. Section 230593 – Testing, Adjusting, and Balancing for HVAC.

1.03 REFERENCES

- A. NFPA 90A – Insulation of Air Conditioning and Ventilation Systems.
- B. UL 181 – Factory-Made Air Ducts and Connectors.
- C. ADC 1062 – Air Distribution and Control Device Test Code.

1.04 CERTIFIED INDEPENDENT TESTING

- A. Prior to providing Submittals, the unit manufacturer is required to submit one powered terminal unit of each size to be used on this project. Unit shall be shipped to the TAB Contractor for testing in their test facility.
- B. Units found to be in compliance with specifications will be returned to unit manufacturer (at their expense) and may be submitted to the A/E for review.
- C. Units found to be in compliance with specifications will be returned to unit manufacturer (at their expense) for modification and/or re-design. All unit sizes will be re-tested by the TAB Contractor (at the expense of the unit manufacturer) until they are brought into total compliance with specifications.

1.05 SUBMITTALS

- A. Indicate on product data the configuration, general assembly, and materials used in fabrication.
- B. Include manufacturer's installation instructions.
- C. Include certified factory test results indicating the noise criteria and sound power and performance characteristics for each unit. Include maximum and minimum cfm ratings at 0.50-

inch wg with the unit on fully bypass or fully primary air with the fan running a medium speed, radiated sound power and discharge sound pressure with the fan on and unit on full bypass, fan horsepower and fan curve, pressure drop through the unit with heating coil and dampers on full bypass. Include schedules listing discharge and radiated sound power level for each of second through sixth octave band at inlet static pressures on one to 4 inch wg (250 to 1,000 Pa).

- D. Provide operation and maintenance manual. Include directions for resetting constant volume generator.

PART 2 - PRODUCTS

2.01 MANUFACTURERS

- A. TITUS Ultra Quiet “Fantom IQ (bases of design)
- B. Nailor (Model 35SEST) “Stealth” series
- C. Krueger
- D. Price

2.02 MANUFACTURED UNITS

- A. Constant volume, fan powered, supply air control terminal for connection to single medium pressure duct, central air system, with variable volume controls, hot water heating coils and fused disconnect switch.
- B. Identify each airflow unit with clearly marked identification label and airflow indicator. Include unit nominal air flow, maximum factory set air flow, minimum factory set air flow, and coil type on label.

2.03 FABRICATION

- A. Casings: Minimum 22 gauge casing with 20 gauge bottom for size 6 to 8 and minimum 20 gauge casing with 18 gauge bottom for sizes 10 and above. Provide stiffeners and construct with sufficient rigidity to prevent vibration due to the action of turbulent air on the panel of the cabinet. Provide entire assembly capable of withstanding a maximum static pressure of 3.0 inches WG. Units shall have full or divided removable bottom access panels with quarter-turn mechanical locks. Unit casing shall all incorporate a minimum of four (one at each corner) galvanized steel angle brackets to accept minimum ½” diameter all-thread rod and vibration isolator. Brackets shall be located as required to allow removal of ductwork, heating coil and air filter without removing unit and shall be a minimum of 1” above bottom of unit casing.
- B. Lining: Provide EPFI Engineered Polymer Foam Insulation or Cotton Liner , NFPA 90A 1 inch thick, 1.5 pounds per cubic foot density, and UL 181 erosion requirements. Cover all exposed parts, such as braces, etc. in contact with exterior surfaces, to prevent condensation on the exterior of the cabinet and minimize both heat and sound transmission.
- C. Assembly: Air volume damper, fans and controls in single cabinet including inlet sound attenuator and renewable media filter in permanent frame.
- D. Plenum Air Inlets: Round/Oval stub connections for duct attachment.
- E. Air Outlets: S and drive connections or 1 inch flange duct attachment.
- F. Limit air leakage from cabinet to a maximum of three percent at 3.0 inches WG interior casing pressure.

2.04 VOLUME DAMPER

- A. Locate air volume damper assembly inside unit casing. Construct from extrude aluminum or 20 gage galvanized steel components. Key damper blades into shaft with nylon fitted pivot points. Secure damper to independent damper rod with a minimum of four screws. Tap damper rod to allow the set screw of the control arm to penetrate the damper rod.
- B. Provide automatic flow control assembly which combines spring rates matched for each volume regulator size with machined dashpot for stable operation.
- C. Mount automatic flow control assembly externally or provide access doors.
- D. Provide factory calibrated assembly consisting of damper and damper shaft extension for connection to externally mounted control actuator.
- E. Provide externally mounted electronic actuator to position damper, normally open, as indicated.

2.05 FAN ASSEMBLY

- A. Forward curved centrifugal type fan of metal construction. Motors must be GE ECM. DC and brushless. Motor must be complete with and operated by a single phase integrated controller/inverter that operates the wound stator and senses rotor position to electrically commutated the stator. All motors must be designed for synchronous rotation. Motor rotor must be permanent magnet type with near zero rotor losses. Motor must have built in soft start and soft speed change ramps. Motor must be able to be mounted with shaft in horizontal or vertical orientation. Motor must be permanently lubricated with ball bearings. Sleeve bearings will not be acceptable. Motor shall be direct coupled to the blower. Motor must maintain a minimum of 70% efficiency over its entire operating range.
- B. The manufacturer of the terminal units must set the fan cfm at the factory. Fan cfm must be constant within +/-5% regardless of changes in static whether upstream or downstream of the terminal unit after it is installed. Fan cfm is to be set with a potentiometer. Neither SCRs nor rheostats are acceptable means of setting fan cfm. A speed adjustment device must be included with the motor for field adjustment should construction or design changes become necessary.
- C. Provide backdraft damper at the return air inlet to prevent backflow of primary air.
- D. Internally suspend and isolate fan/motor assembly from casing on rubber isolator to prevent noise and vibration transmission from the fan/motor assembly to the casing.
- E. Provide fan/ motor assembly with a service life of 15 years.
- F. Provide capacitor or controls to allow rotation of the fan only in the proper direction regardless of condition of fan at start up.
- G. Provide non-overloading type system with fan/motor assembly sized to supply all downstream static pressure requirements.

2.06 HEATING COILS

- A. Electrical heating coils installed in conjunction with single duct terminal units shall be factory installed, heating element shall be Nickel chrome complete with auto reset thermal cut outs, magnetic contactors, airflow safety switches, control transformer for automatic controls and fan relay for fan terminal. Provide at least SCR control for the heating coils.

2.07 WIRING

- A. Factory mount and wire controls. Mount electrical components in control box with removable cover. Incorporate single point electrical connection to power source.
- B. Factory mount transformer for control voltage on electric and electronic control units. Provide terminal strip in control box for field wiring of thermostat and power source.

- C. Factory wire fan to terminal strip.
- D. Provide factory installed fused disconnect switch.

2.08 CONTROLS

- A. Automatic Damper Operator:
 - 1. Operate: Air volume damper and automatic volume control.
 - 2. Electric Damper Operator: 24 volt (normally closed).
 - 3. Maximum Volume Controller and Probe: Electronic, with calibration pressure taps for high flow limited proportional variable air volume control.
 - a. Velocity Reset Controller and Probe: Electronic, with calibration pressure taps for pressure independent proportional variable air volume with means for pressure independent compensating for varying inlet static pressure, with minimum and maximum limits set at reset device, mounted in control box.

2.09 FAN POWERED UNIT CONTROLS

- A. Contain in NEMA-1 enclosure with access panel sealed from air flow and mounted on side of unit. The Terminal Equipment Controllers (TEC) shall be furnished by the BMCS System Manufacturer to the unit manufacturer for installation, wiring and testing at their factory. The factory mounted controls shall accomplish the following specified Sequence of Operation.
- B. Electronic Control Occupied Mode:
 - 1. When duct pressure is sensed indicating primary air system operating, and primary variable volume damper proportions air flow from BMCS and fan operates.
 - 2. As space sensors senses reduced cooling demand, volume damper closes. As cooling demand continues to fall, volume damper closes.
 - 3. Velocity reset primary air control (pressure independent) with maximum and minimum limits.
 - 4. Hi-limit device, factory set, limits maximum primary air flow.
 - 5. As space sensor calls for less cooling, control system closes volume damper to minimum stop from central system primary air duct before heating is initiated. On sensing further need for heat, heating coil is energized.
- C. Electronic Control – Unoccupied Mode:
 - 1. DDC Control System cycles fan and controls at reduced temperature (day/night setback).

2.10 SOUND PERFORMANCE CRITERIA

- A. The following chart reflects maximum allowable discharge and radiated sound power level

				Maximum Radiated Sound Power Level, dB, at Band No. and Center Freq., Hz				
Unit Size	Inlet Dia.	Fan and 100% Primary, CFM	2 125	3 250	4 500	5 1,000	6 2,00	7 4,00
4	8	250 to 500	55	55	50	42	39	31
4	10	501 to 800	63	60	56	49	44	37
4	12	801 to 1,150	70	65	61	55	49	43
6	12	1,151 to 1,400	68	64	58	53	47	42
6	14	1,401 to 1,600	71	66	60	56	50	44
6	16	1,601 to 2,050	75	7	64	60	55	49
				Maximum Discharge Sound Power Level, dB, at Band No. and Center Freq., Hz				
Unit Size	Inlet Dia.	Fan and 100% Primary, CFM	2 125	3 250	4 500	5 1,000	6 2,00	7 4,00
4	8	250 to 500	62	57	55	51	47	47
4	10	501 to 800	68	64	59	58	55	55
4	12	801 to 1,150	73	69	64	63	61	61
6	12	1,151 to 1,400	72	63	63	62	60	60
6	14	1,401 to 1,600	74	66	65	64	63	60
6	16	1,601 to 2,050	78	69	69	67	66	65
Note: All ratings at 1.0" wc Inlet Static Pressure and 0.25" wc Discharge Static Pressure Up to +2dB variation allowed. Based Upon Titus TQS Constant Volume with ECM (for Extended Range Operation)								

PART 3 - EXECUTION

3.01 INSTALLATION

- A. Install in accordance with manufacturer's instructions.
- B. Ensure 3 feet accessibility around the unit.
- C. Provide ceiling access doors or locate units above easily removable ceiling components.

- D. Support units individually from building structure. Do not support from adjacent ductwork. (No Exceptions.)
- E. Refer to Section 233100 for connections to equipment.
- F. Install heating coils in accordance with detail on Drawings.
- G. Install disposable filters in accordance with Section 234100.

END OF SECTION

SECTION 233713 - DIFFUSERS, REGISTERS, AND GRILLES

PART 1 - GENERAL

1.01 RELATED DOCUMENTS

- A. Drawings and general provisions of the Contract, including General and Supplementary Conditions and Division 01 Specification Sections, apply to this Section.

1.02 SUMMARY

- A. Section Includes:
 - 1. Round ceiling diffusers.
 - 2. Rectangular and square ceiling diffusers.
 - 3. Perforated diffusers.
 - 4. Louver face diffusers.
 - 5. Linear bar diffusers.
 - 6. Linear slot diffusers.
 - 7. Ceiling-integral continuous diffusers.
 - 8. Drum louvers.
 - 9. Modular core supply grilles.
 - 10. Continuous tubular diffusers.
- B. Related Sections:
 - 1. Division 08 Section "Louvers and Vents" for fixed and adjustable louvers and wall vents, whether or not they are connected to ducts.
 - 2. Division 23 Section "Air Duct Accessories" for fire and smoke dampers and volume-control dampers not integral to diffusers, registers, and grilles.

1.03 SUBMITTALS

- A. First three paragraphs below are defined in Division 01 Section "Submittal Procedures" as "Action Submittals."
- B. Product Data: For each type of product indicated, include the following:
 - 1. Data Sheet: Indicate materials of construction, finish, and mounting details; and performance data including throw and drop, static-pressure drop, and noise ratings.
 - 2. Diffuser, Register, and Grille Schedule: Indicate drawing designation, room location, quantity, model number, size, and accessories furnished.
- C. Samples for Initial Selection: For diffusers, registers, and grilles with factory-applied color finishes.
- D. Samples for Verification: For diffusers, registers, and grilles, in manufacturer's standard sizes to verify color selected.
- E. Coordination Drawings: Reflected ceiling plans, drawn to scale, on which the following items are shown and coordinated with each other, using input from Installers of the items involved:
 - 1. Ceiling suspension assembly members.
 - 2. Method of attaching hangers to building structure.
 - 3. Size and location of initial access modules for acoustical tile.

4. Ceiling-mounted items including lighting fixtures, diffusers, grilles, speakers, sprinklers, access panels, and special moldings.
 5. Duct access panels.
- F. Source quality-control reports.

PART 2 - PRODUCTS

Refer to drawings for schedule.

2.01 SOURCE QUALITY CONTROL

- A. Verification of Performance: Rate diffusers, registers, and grilles according to ASHRAE 70, "Method of Testing for Rating the Performance of Air Outlets and Inlets."

PART 3 - EXECUTION

3.01 EXAMINATION

- A. Examine areas where diffusers, registers, and grilles are to be installed for compliance with requirements for installation tolerances and other conditions affecting performance of equipment.
- B. Proceed with installation only after unsatisfactory conditions have been corrected.

3.02 INSTALLATION

- A. Install diffusers, registers, and grilles level and plumb.
- B. Ceiling-Mounted Outlets and Inlets: Drawings indicate general arrangement of ducts, fittings, and accessories. Air outlet and inlet locations have been indicated to achieve design requirements for air volume, noise criteria, airflow pattern, throw, and pressure drop. Make final locations where indicated, as much as practical. For units installed in lay-in ceiling panels, locate units in the center of panel. Where architectural features or other items conflict with installation, notify Architect for a determination of final location.
- C. Install diffusers, registers, and grilles with airtight connections to ducts and to allow service and maintenance of dampers, air extractors, and fire dampers.
- D. All exterior louvers shall have wire bird screens mounted in removable metal frames.

3.03 ADJUSTING

- A. After installation, adjust diffusers, registers, and grilles to air patterns indicated, or as directed, before starting air balancing.

END OF SECTION

SECTION 238133 - UNITARY SPLIT SYSTEM AIR CONDITIONERS

PART 1 – GENERAL

1.01 SECTION INCLUDES

1. Air handling/fan coil unit.
2. Outdoor condensing unit.
3. Plenum/pedestal.
4. Thermostat.

1.02 RELATED SECTIONS

- A. Section 22 07 16 - Plumbing Piping Insulation.
- B. Section 23 05 13 – Common Motor Replacements for HVAC.
- C. Section 23 05 93 - Testing, Adjusting, and Balancing for HVAC.
- D. Section 23 07 19 - HVAC Piping Insulation.
- E. Section 23 09 23 - Direct-Digital Control System for HVAC.
- F. Section 23 09 33 - Electric and Electronic Control System for HVAC.
- G. Section 23 23 00 - Refrigerant Piping.
- H. Section 23 23 16 - Refrigerant Piping Specialties.

1.03 REFERENCES

- A. ARI 240 - Air Source Unitary Heat Pump Equipment.
- B. ARI 270 - Sound Rating of Outdoor Unitary Equipment.

1.04 SUBMITTALS

- A. Unit applications to be verified by Owner.
- B. Include product data and schematic layouts showing condensing units, air handling/fan coil unit, refrigerant piping and accessories required for complete system. Include complete pipe sizing data.
- C. Include rated capacities, dimensions, weights, accessories, required clearances, electrical requirements, wiring diagrams and location and size of field connections.
- D. Include manufacturer's installation instructions.
- E. Provide operation and maintenance manual.

1.05 QUALITY ASSURANCE

- A. Provide capacity ratings with ARI certification.

1.06 WARRANTY

- A. Provide five-year manufacturer's replacement warranty on compressor.

PART 2 - PRODUCTS

2.01 ACCEPTABLE MANUFACTURERS

- A. Liebert.
- B. Carrier.
- C. York.
- D. Trane.

2.02 SYSTEM DESCRIPTION

- A. Provide split system air conditioning system consisting of indoor air handling/fan coil unit, outdoor condensing unit, refrigerant piping, fittings and accessories, and controls. Factory assemble components and test unit.
- B. Heating and Cooling Capacities: As indicated on Drawings.

2.03 AIR HANDLING/FAN COIL UNIT

- A. Basic Unit:
 - 1. Fabricated exterior unit casing of heavy gauge galvanized steel, painted with epoxy based enamel paint. Provide color chart for color selection by Architect.
 - 2. All unit panels must be removable with a minimum 2 inch microbial resistant and cleanable glass fiber thermal insulation liner with sealed edges.
 - 3. Fabricate fan deck of galvanized steel. Fabricate drain pans of 304 stainless steel externally insulated with fire retardant, closed cell foam insulation.
 - 4. Provide with integral double deflection supply grilles and hinged bar return grilles, unless otherwise indicated on the drawings to have ductwork connections with 1" duct collars, and one inch filter frame.
- B. Coils:
 - 1. Construct coils with 2" O.D. copper tubes with aluminum fins mechanically bonded to the tubes.
 - 2. Test all coils for design working pressure of 250 psig @ 200EF.
 - 3. Heating and cooling coils shall be sized as required to meet or exceed the capacities indicated on the drawings.
- C. Fans: Centrifugal, forward-curved, double-width wheels. Mount frame on vibration isolators.
- D. Motors: Resilient mounted, three-speed, permanent split capacitor type in total compliance with Section 23 05 13 – Common Motor Requirements for HVAC.
- E. Filters: 1 inch disposable with galvanized holding frame in total compliance with Section 23 41 00 - Particulate Air Filtration.

2.04 AIR COOLED CONDENSING UNITS

- A. Provide air cooled condensing units as scheduled; self-contained, packaged, factory assembled and pre-wired units suitable for outdoor use consisting of cabinet, compressors, condensing coil and fans, integral sub-cooling coil, controls, liquid receiver and screens.
- B. Provide corrosion resistant materials for unit parts which come in contact with refrigerant.
- C. Provide timer conduits to prevent rapid cycling of compressor.
- D. Fabricate cabinet from galvanized steel, with baked enamel finish; provide removable access

doors or panels with quick fasteners.

- E. Compressor: [Hermetically sealed or semi-hermetic type], 1750 rpm, resiliently mounted with positive lubrication, crankcase heater, cylinder unloaders for capacity modulation, motor overload protection, service valves, filter drier, suction and discharge valves, with gauge ports, and high and low pressure safety controls.
- F. Condenser:
 - 1. Seamless copper tubing with aluminum fins coil.
 - 2. Provide condenser fans which discharge, vertically and have direct drive fans resiliently mounted with guard and motor.
 - 3. Provide fan motor with permanently lubricated ball bearing type with built-in current and overload protection.
- G. Provide unit with high and low pressure cutouts for compressor, non-recycling pump down, reset relay and oil pressure safety control (7 1/2 ton units and larger). Provide with controls to permit operation down to 0 degree F ambient temperature at minimum compressor load.

2.05 PIPING

- A. Provide one refrigerant line filter dryer and outside pressure taps in each refrigerant circuit.

2.06 CONTROLS

- A. Refer to: Section 23 09 23 - Direct-Digital Control System for HVAC.

PART 3 – EXECUTION

3.01 INSTALLATION

- A. Install in accordance with manufacturer's instructions.
- B. Verify proper refrigerant charge and operating pressures. Supplement factory charge (R-410) if necessary.
- C. Mount unit in safe and accessible location for maintenance.

END OF SECTION

SECTION 260500 - COMMON WORK RESULTS FOR ELECTRICAL

PART 1 - GENERAL

1.01 RELATED DOCUMENTS

- A. Drawings and general provisions of the Contract, including General and Supplementary Conditions and Division 01 Specification Sections, apply to this Section.

1.02 SUMMARY

- A. Section Includes:
 - 1. Summary of Work.
 - 2. Submittals, Analysis and Device Schedules.
 - 3. Record Documents.
 - 4. Operating and Maintenance Manuals.
 - 5. General Electrical Product Requirements.
 - 6. General Electrical Installation Requirements.
 - 7. Electrical equipment coordination and installation.
 - 8. Sleeves for raceways and cables.
 - 9. Sleeve seals.
 - 10. Grout.
 - 11. Common electrical installation requirements.
- B. Provide all work required for complete electrical and ancillary system as indicated on the drawings and in these specifications. This may include, but is not necessarily limited to; panelboards, transformers, cabinets, motor controllers, circuit breakers, fuses, disconnect switches, surge suppression, fire alarm system, Lighting Control System, interior and exterior lighting, parking lot lighting, lamps, relay panels, contactors, controls, wiring devices, wire and cable, grounding and bonding, lightning protection, equipment wiring system, conduit, raceways, boxes, supporting devices, identification, fire stopping, testing, excavating, concrete equipment bases, concrete duct encasements, conduit sleeves and supports, anchors, vibration and sound isolation, access panels, record drawings, installation permits, inspections by governing authorities, electrical work of certain temporary facilities and services, cutting-and-patching work, utility connection coordination, start-up of electrical systems and equipment, training of Owner's operating personnel, operating and maintenance manuals, final cleaning of electrical and similar work.
- C. Except where otherwise indicated, electrical drawings prepared by Engineer (contract drawings) are diagrammatic in nature and may not show locations accurately for various components of electrical systems. It is the intention of the Construction Documents to establish the types and functions of the systems, but not to set forth each and every item essential to the functioning of any system. The Contractor shall make necessary changes or additions as may be reasonably inferred from the construction documents for a complete operating system as required and record these on the record documents at no cost to the Owner.
- D. Contractor shall visit site prior to submitting his proposal and become familiar with the conditions under which the Work is to be performed, and correlate site observations with the requirements of the Contract Documents. Errors, inconsistencies or omissions discovered shall be reported to the Architect/Engineer at once.

- E. All electrical products and installations shall comply with the latest additions of the following standards where applicable:
1. ADA - AMERICANS WITH DISABILITIES ACT
 2. ANSI - AMERICAN NATIONAL STANDARDS INSTITUTE
 3. ASTM - AMERICAN SOCIETY FOR TESTING AND MATERIALS
 4. CBM - CERTIFIED BALLAST MANUFACTURERS
 5. ETL - ELECTRICAL TESTING LABORATORIES
 6. FM - FACTORY MUTUAL
 7. ICEA - INSULATED CABLE ENGINEERS ASSOCIATION
 8. IEEE - INSTITUTE OF ELECTRONICS AND ELECTRICAL ENGINEERS
 9. NEC - NATIONAL ELECTRICAL CODE
 10. NECA - NATIONAL ELECTRICAL CONTRACTORS ASSOCIATION
 11. NEMA - NATIONAL ELECTRICAL MANUFACTURERS ASSOCIATION
 12. NESC - NATIONAL ELECTRICAL SAFETY CODES
 13. NFPA - NATIONAL FIRE PROTECTION ASSOCIATION
 14. NETA - INTERNATIONAL ELECTRICAL TESTING ASSOCIATION
 15. OSHA - OCCUPATIONAL SAFETY AND HEALTH ASSOCIATION
 16. UBC - UNIFORM BUILDING CODE
 17. IBC – INTERNATIONAL BUILDING CODE
 18. ICC – INTERNATIONAL CODE COUNCIL
 19. IECC – INTERNATIONAL ENERGY CONSERVATION CODE
 20. ISO – INTERNATIONAL ORGANIZATION FOR STANDARDIZATION
 21. UL - UNDERWRITERS LABORATORIES, INC.
 22. STATE ENERGY CONSERVATION CODE
 23. MUNICIPAL OR COUNTY CODES. IN THE EVENT OF CONFLICTS BETWEEN CODES OR STANDARDS, THE MORE STRINGENT REQUIREMENTS SHALL GOVERN
- F. All work and materials shall be warranted as indicated in Division 1.
- G. Contractor is responsible for filing and paying for all fees and obtaining necessary permits and certificates of inspection, and shall deliver all certificates of inspection to Owner, and include copies with maintenance manuals.

1.03 SUBMITTALS

- A. General Submittal Requirements:
1. All submittals shall be in accordance with Division 1 requirements.
 2. Submit number of copies indicated in Division 1 or 6 copies, whichever is greater.
 3. Applicability: Wherever it is indicated that shop drawings, samples, manufacturer's brochure, certification, test, copy of standard operating instructions, manual, extra stock, or warranty is required, appropriate submittal is required regardless of whether it is specified as "submittal"; Engineer's decision shall be final.
 4. Do not purchase equipment until submittals have been reviewed by Engineer with no exceptions taken.

5. Signed Commitments: Do not proceed with transfer of electrical systems to Owner for operation until warranties, performance certifications, maintenance agreements and similar commitments to be signed by Contractor and other entities have been executed and transmitted to Engineer (for Owner's records).
 6. Response to Submittals: Where standard product data have been submitted in fulfillment of project requirements, it is recognized that submitter has already determined that products fulfill specified requirements, and that submittals are for engineer's information only, but will be returned without action where observed to be non-complying with requirements. Where uniquely prepared information is submitted, it is recognized to represent preparer's interpretation or solution to specified requirements, subject to Engineer's concurrence and appropriate action as indicated in Division 1.
 7. Submittals shall be signed by the General Contractor and Subcontractor responsible for this work.
 8. The Engineer's review of submittals is solely for general conformance with the design concept. The Engineer's review does not relieve the Contractor from total responsibility for quantities, errors, omissions or compliance with the intent of the original contract documents. Review and approval by the Contractor is required before fabrication, shipment or installation.
- B. Substitutions: Electrical submittals are not opportunities for gaining acceptance of substitutions. Any variance from the contract documents shall be identified in accordance with Division 1 requirements. Substitutions will be reviewed only for those reason identified in Division 1 and only if the procedures identified in Division 1 are followed. Any variances from the contract documents in the submittals which are not identified by the Contractor in accordance with the procedures of Division 1 and subsequently not identified by the Engineer's review shall be corrected by the Contractor at no cost to the Owner. Substitution request would only be considered if product is equal or better than what listed. No substitution will be allowed for fire alarm system.
- C. Coordination Drawings: Prior to any submittals being reviewed, the Contractor shall provide the coordination drawings indicated in Division 1. In accordance with Division 1, the coordination drawings shall show work in and above ceilings and in mechanical and electrical rooms with horizontal and vertical dimensions to avoid interference with structural framing, ceilings, partitions and other services. The coordination drawings shall be to a scale of 1/4" = 1'-0" or larger. Coordination drawings in the buildings shall include but not be limited to all Electrical rooms with size and location, major electrical equipment and accessories, switchgear and clearances, HVAC ductworks in rooms, plumbing, air grilles, light fixtures, communications equipment, access panels, transformers, switchboards, panelboards, control panels, fire alarm equipment, code clearances for equipment, manufacturers required maintenance clearance for equipment, concrete equipment pads, exterior wall penetrations, foundation penetrations, and fire rated wall penetrations.
- D. Short Circuit Analysis: Prior to any electrical submittals being reviewed, the contractor shall perform short-circuit analysis of the specified electrical power distribution system. This analysis shall include:
1. A calculation of the maximum RMS symmetrical three-phase short-circuit current available at each panel location in the electrical system. The results shall represent the highest short-circuit currents to which the equipment might be subjected under the reported system conditions. The short circuit currents shall be calculated with the aid of a computer. The contractor shall obtain necessary information from the utility to do this.

2. Appropriate motor short-circuit contribution such that the calculated values will represent the highest short-circuit current to which the equipment will be subjected under fault conditions.
 3. A tabular computer printout of equipment supplied by the electrical ratings of the electrical equipment supplied by the electrical manufacturer, the calculated short-circuits currents, X/R ratios, and notes regarding the adequacy or inadequacy of the equipment.
 4. A computer printout of input circuit data including cable lengths, number of cables per phase, cable impedance values, insulation types, transformer impedances, X/R ratios and other circuit information as related to the short-circuit calculations.
 5. A bus-to-bus computer print out listing the maximum available short-circuit current in RMS symmetrical amperes and the X/R ratio of the fault current. This printout shall have an accompanying printout explaining how to interpret the short-circuit results.
 6. A computer-generated system one-line diagram clearly identifying individual equipment buses, bus numbers used in short-circuit analysis, cable and bus connections between the equipment and calculated maximum short-circuit current at each bus location.
 7. A discussion section evaluating the adequacy or inadequacy of the equipment, with recommendations as required for improvements to the system.
 8. Any inadequacies shall be called to the attention of the engineer and recommendations made for improvements.
 9. Six bound copies of the completed short-circuit analysis sealed by professional engineer with Texas registration shall be submitted for the engineer review.
- E. Protective Device Time-Current Coordination Analysis: Prior to any electrical equipment submittals being reviewed, the contractor shall perform a protective device time-current coordination analysis of the specified electrical power distribution system. This analysis shall include:
1. A determination of settings, ratings, or types for the over-current protective devices supplied. Where necessary, an appropriate compromise shall be made between system protection and service continuity with:
 - a. System protection shall be more important than service continuity. The time current condition analysis shall be performed with the aid of a computer.
 2. Computer generated log-log plots containing the time current characteristics of over-current devices. A sufficient number of log-log plots shall be provided to indicate the degree of system protection and coordination. The log-log plots shall include transformer ANSI withstand point and inrush currents of transformers where appropriate. Series rated devices shall not be acceptable.
 3. Computer printouts to accompany the log-log plots containing descriptions for each of the devices shown on the plot, setting of the adjustable devices, device numbers to simplify locations of the devices on the system one-line diagram and short circuits where shown.
 4. A tabular computer printout of the suggested settings of the adjustable over-current protective devices, the equipment where the devices are located, the device number corresponding to the device on the system one-line diagram and the number of the time-current log-log graphs where they are illustrated.
 5. A computer generated system one-line diagram clearly identifying individual equipment buses, the bus numbers, the device numbers and the maximum available short-circuit at each bus which shall include short-circuit current motor contributions.

6. A discussion section evaluating the degree of system protection and service continuity with over-current devices, with recommendations as required for increased protection or coordination.
 7. Any inadequacies shall be called to the attention of the engineer and recommendations made for improvements.
 8. Six bound copies of the completed protective device time-current coordination analysis for the engineer.
- F. Over-current Device Schedule: Prior to any electrical submittals being reviewed, contractor shall provide a schedule for each piece of equipment required by Divisions 11, 14, 21, 22, 23, 25, 27, and 28 in coordination with subcontractors providing equipment under these sections. Submittals shall reflect required coordination by having related contractor's signatures on the submittals. This means that electrical requirement for chiller as an example, shall be coordinated by BOTH Electrical and Mechanical subcontractors, and Over-Current Device Schedule submitted shall be signed by both contractors. For each piece of equipment actually supplied, the schedule shall indicate the full load amps (FLA), the minimum circuit amps (MCA), and the maximum over-current protection device (MOCPD). The schedule shall also indicate if the equipment is required to be protected by fuses only, thermal magnetic breaker only, HACR breakers only or any combination thereof. It shall also indicate if the equipment requires single point or multiple point of connections and how the contractor is proposing to meet the requirements if different than construction documents. It shall explicitly indicate the required number of conductors, disconnect switch sizes and numbers (if required), and acceptable conduit sizes and number. These modifications shall be reflected in the electrical equipment submittal. Required changes shall be made at no cost to the Owner.
- G. After the coordination drawings, short circuit analysis coordination analysis and over-current device schedule are submitted, the products in Division 16 shall be submitted in the groups identified below. By submitting shop drawings on the project, this contractor is indicating that all necessary coordination has been completed and that the systems, products and equipment submitted can be installed in the building and will operate as specified and intended, in full coordination with all other trades. Submittals for each group will be returned without review unless all sections are included. Sections will not be reviewed separately. At the Engineer's discretion, when a re-submittal is required for one section, any other sections within each group may require re-submittal. Contractor shall expedite submittals and re-submittals as required to allow for the Engineer's review time specified in Division 1. The groups of equipment shall be divided as follows:
1. Raceways, Conductors and Miscellaneous Equipment
 - b. Fire stopping
 - c. Conduit
 - d. Raceways, Multi-outlet Assemblies, Wireways and Auxiliary Gutters
 - e. Wires and Cables
 - f. Outlet Boxes
 - g. Wiring Devices
 - h. Cabinets and Enclosures
 - i. Grounding and Bonding
 - j. Supporting Devices
 - k. Electrical Identification
 - l. Lightning Protection Systems

2. Distribution Equipment
 - a. Distribution Switchboards
 - b. Enclosed Switches
 - c. Dry Type Transformers
 - d. Distribution Panelboards
 - e. Branch Circuit Panelboards
 - f. Enclosed Motor Controllers
 - g. Motor Control Center
 - h. Variable Speed Drives
 - i. Electrical Controls
 3. Emergency Backup System
 - a. Enclosed Transfer Switches
 - b. Diesel Generator Sets
 4. Lighting Fixtures
 - a. Interior and Building Lighting Fixtures
 5. Specialty Systems
 - a. Transient Voltage Surge Suppression
 - b. Fire Alarm System
 - c. Intercom System
 - d. Cable TV System
 - e. Local sound reinforcement System
 6. Testing
 - a. Field Electrical Testing
- H. Shop Drawings: Prepare electrical shop drawings to accurate scale except where diagrammatic representations are specifically indicated. Show clearance dimensions of critical locations, and show dimensions of spaces required for operation and maintenance of equipment. Show conduit layouts and wire/cable connections and other electrical service connections and show interfaces with other work, including structural support. Indicate by note, portions of electrical work shown on shop drawings which deviates from indication of work in contract documents, and explain reasons for deviations. Show how such deviations coordinate with interfacing deviations on shop drawings for other portions of work, currently or previously submitted. Show wiring diagrams, erection, setting, weights, capacities, speeds, outputs, consumption, efficiencies, voltages, amperages, hertz, phases, noise levels, etc.
- I. Samples: Engineer's review of required sample submittals will be limited to observation of general type, pattern, and finish; and will not include testing and inspection of submitted samples, except for those specifically indicated for that purpose in the contract documents. Compliance with specified requirements remains the exclusive responsibility of the Contractor.
- J. Manufacturer's Data: Where pre-printed data covers more than one distinct product, size, type, material, trim, accessory group or other variation, mark submitted copy with black pen to indicate which variations are to be provided. Delete or mark-out all portions or pre-printed data which are not applicable. Where operating ranges are shown, mark data to show portions of range required for project application. Expansion or elaboration of standard data to describe non-standard product must be processed as shop drawing data to describe non-standard product.

For each product include manufacturer's production specifications, installation or fabrication instructions, nearest source of supply (including telephone number), sizes, weights, speeds, operating characteristics, ratings, conduit and wire/cable connection sizes and locations, statements of compliance with required standard and governing regulations (include manufacturer's signed statements if not covered in printed data), performance data (where applicable) and similar information needed to confirm compliance with requirements.

- K. **Manufacturer's Certification:** Each manufacturer is required to review the system design as related to the proper operation of his equipment, including electrical requirements, automatic controls, mechanical systems and equipment locations and related items. With shop drawings submit a letter from the manufacturer stating that his equipment will operate satisfactorily under the design conditions. The manufacturer's representative shall review the final installation at the site and submit a second letter stating that the equipment operates satisfactorily as installed. Furnish certification for the systems listed in each section of Division 16.
- L. **Test Reports:** The contractor for various sub-systems shall submit proposed testing procedure for their system, subject to review and approval and owner acceptance. The contract will not be declared to be substantially complete until the functional operation of the subsystems have been demonstrated and verified and reports have been provided, reviewed and accepted. The project will not be declared substantially complete until the following has taken place:
 - 1. The "As-Built" drawings have been submitted, reviewed, and accepted by HISD CM-PA/Bond Office.
 - 2. The various systems have been commissioned and accepted. This will include the following systems:
 - a. Building Fire Alarm System
 - b. Clock System
 - c. Television Distribution System
 - d. Building Computer Network
 - e. Surveillance and Security System
 - f. Intercom/Telephone
- M. Submit test report signed and dated by firms performing test, and prepare in manner specified in standard or regulation governing test procedure as indicated. Provide notarized executions on test reports.
- N. **Warranties:** Refer to Division 1 for procedures and submittal requirements for warranties. Refer to individual equipment specifications for warranty requirements. A minimum of one-year warranty period is required for all materials and equipment. Warranty period starts upon first beneficial use or acceptance by HISD whichever comes first.
 - 1. Provide complete warranty information for each item to include product or equipment to include date of beginning of warranty or bond; duration of warranty or bond; names, addresses and telephone numbers and procedures for filing a claim and obtaining warranty services.
 - 2. Where pre-printed and published warranty includes substantial deviation from required warranty (as judged by Engineer), product is automatically disqualified from use on project, except where manufacturer prepares and issues specific project, warranty on product, stating that it is in lieu of published warranty, and is executed by authorized officer, and complies with requirements.

- O. Load Current and Overload Relay Heater List: Compiled by Contractor after motors have been installed. Arrange to demonstrate selection of heaters to suit actual motor nameplate full load currents.

1.04 RECORD DOCUMENTS

- A. Prepare record documents in accordance with the requirements in Division 1. In addition to the requirements specified in Division 1, indicate installed conditions for:
 - 1. Major raceway systems, size and location, for both exterior and interior; locations of control devices; distribution and branch electrical circuitry; access panels; and fuse and circuit breaker size and arrangements.
 - 2. Equipment locations (exposed and concealed), dimensioned from prominent building lines.
 - 3. Approved substitutions, Contract Modifications, and actual equipment and materials installed.
 - 4. Underground cabling and conduits both interior and exterior, drawn to scale and fully dimensioned.
 - 5. Work concealed behind or within other work, in a non-accessible arrangement.
 - 6. Mains and branches of wiring/cabling systems, with switchboards, panelboards, and control equipment and devices located and numbered with terminals and connections located, and with equipment requiring maintenance located.
 - 7. Grounding systems including primary, secondary and special.
- B. Execution: Each installer or other entity responsible for recording installed work shall record firm name, signature and date on each drawing so marked.
- C. Prior to transmittal of corrected drawings, obtain three (3) sets of blue-line prints of each drawing in each set, regardless of whether corrections were necessary, and include in transmittal (two (2) sets are for Owner's use, and one (1) is for Engineer's records).

1.05 OPERATING AND MAINTENANCE MANUALS

- A. Prepare maintenance manuals in accordance with Division 1. In addition to the requirements specified in Division 1, provide the following.
- B. Submit sets prior to final inspection, in 8½ x 11 inch text pages, bound in style D, three ring binders with durable plastic covers.
- C. Prepare binder cover with printed title "OPERATION AND MAINTENANCE INSTRUCTIONS, ELECTRICAL", and title of project.
- D. Internally sub-divide the binder contents with permanent page dividers, logically organized, with tab titling clearly printed under reinforced laminated plastic tabs.
- E. Contents:
 - 1. Directory, listing names, addresses, and telephone numbers of Architect/Engineer, Contractor, Subcontractor, and major equipment suppliers.
 - 2. Operation and maintenance instructions, arranged by system.
 - 3. Project documents and certificates.
 - 4. Description of function, normal operating characteristics and limitations, performance curves, engineering data and tests, and complete nomenclature and commercial numbers of replacement parts.
 - 5. Manufacturer's original printed operating procedures to include start-up, break-in, and routine and normal operating instructions; regulation, control, stopping, shutdown, and

emergency instructions; and summer and winter operating instructions. (Copies are not acceptable).

6. Maintenance procedures for routine preventative maintenance and troubleshoot; disassembly, repair, and re-assembly; aligning and adjusting instructions.
 7. Servicing instructions and lubrication charts and schedules.
 8. Warranty information including any corrections made during submittals.
 9. Replacement parts list.
 10. List of tools and accessories needed for maintenance.
 11. COORDINATION
- F. Coordinate arrangement, mounting, and support of electrical equipment:
1. To allow maximum possible headroom unless specific mounting heights that reduce headroom are indicated.
 2. To provide for ease of disconnecting the equipment with minimum interference to other installations.
 3. To allow right of way for piping and conduit installed at required slope.
 4. So connecting raceways, cables, wireways, cable trays, and busways will be clear of obstructions and of the working and access space of other equipment.
- G. Coordinate installation of required supporting devices and set sleeves in cast-in-place concrete, masonry walls, and other structural components as they are constructed.
- H. Coordinate location of access panels and doors for electrical items that are behind finished surfaces or otherwise concealed. Access doors and panels are specified in Division 08 Section "Access Doors and Frames."
- I. Coordinate sleeve selection and application with selection and application of firestopping specified in Division 07 Section "Penetration Firestopping."

PART 2 - PRODUCTS

2.01 GENERAL MANUFACTURER QUALIFICATION:

- A. Production Experience: For all electrical equipment, manufacturer shall be firm with not less than five (5) years successful production experience. Experience means production of units similar to those required, as judged by Engineer. Comply with longer-period experience requirements specified in other Division 16 sections of these specifications. Product shall be new and design for quiet, vibration free operation.

2.02 GENERAL ELECTRICAL PRODUCT REQUIREMENTS:

- A. Standard Products: Provide not less (quality) than manufacturer's standard products as specified by published product data. Do not assume that available off-the-shelf condition of product complies with requirements; as example, specific finish or color may be required.
- B. Unencumbered Purchases: Avoid purchases and use of products which are encumbered with questionable title transfers, patent rights, trade union restrictions, code compliance, non-listings as "approved products" for compliance with governing regulations, duties due, embargoes and similar possible encumbrances, claims or sellers interest.
1. Purchasing: Do not purchase specific electrical materials and equipment for project until completion of submittals.

- C. Condition of Products: Except as otherwise indicated, provide new electrical products, free of defects and harmful deterioration at time of installation. Do not use units, which have been subjected to destructive testing, or other high-limits testing except where pre-tested products are specified. Comply with Division 1 requirements for exposure or visual display limitations against trademarks and manufacturer's names. Provide each product complete with trim, accessories, finish, guards, safety devices and similar components specified or recognized as integral parts of products, or required by governing regulations.
- D. Assembly and Testing: To greatest extent possible and unless otherwise indicated, complete fabrication, assembly, finishing and testing of products prior to delivery to project. Notify Engineer not less than one week in advance of pre-installation testing to be performed in response to project requirements. Engineer reserves right to be present at tests of electrical products; however, neither their absence nor presence relieves the Contractor of responsibility for compliance with requirements.
- E. Uniformity: Where multiple units of generic product are required for single major system of electrical work, e.g., cable trays, lighting systems, provide identical products by same manufacturer, without variations.
 - 1. Limitations: Product/manufacturer uniformity does not apply to conduit and fittings, 600V electrical wire, sheet metal, steel bar stock, welding rods, solder, factory applied paint between different systems, fasteners, motors for unlike equipment units, and similar items used in work, and except as otherwise indicated.
- F. Product Compatibility, Options: Where more than one product selection is specified, selections are Purchaser's or Installer's options, except do not provide products which are not compatible with previously purchased or installed products which must interface with selections. Provide electrical adaptations as needed for interfacing of selected products in work.
- G. Quality Assurance: Provide products listed by and installed in accordance with all references in each section under quality assurance any other applicable requirements.
- H. Elevation Requirements: Electrical equipment provided shall perform at mean elevation of 1000 feet above sea level.

2.03 SLEEVES FOR RACEWAYS AND CABLES

- A. Retain one of first two paragraphs below for penetrations through exterior walls above and below grade.
- B. Steel Pipe Sleeves: ASTM A 53/A 53M, Type E, Grade B, Schedule 40, galvanized steel, plain ends.
- C. Cast-Iron Pipe Sleeves: Cast or fabricated "wall pipe," equivalent to ductile-iron pressure pipe, with plain ends and integral water-stop, unless otherwise indicated.
- D. Sleeves for Rectangular Openings: Galvanized sheet steel.
 - 1. Minimum Metal Thickness:
 - a. For sleeve cross-section rectangle perimeter less than 50 inches and no side more than 16 inches, thickness shall be 0.052 inch.
 - b. For sleeve cross-section rectangle perimeter equal to, or more than, 50 inches and 1 or more sides equal to, or more than, 16 inches, thickness shall be 0.138 inch.

2.04 SLEEVE SEALS

- A. Description: Modular sealing device, designed for field assembly, to fill annular space between sleeve and raceway or cable.

2.05 GROUT

- A. Nonmetallic, Shrinkage-Resistant Grout: ASTM C 1107, factory-packaged, nonmetallic aggregate grout, noncorrosive, non-staining, mixed with water to consistency suitable for application and a 30-minute working time.

PART 3 -EXECUTION

3.01 GENERAL ELECTRICAL INSTALLATIONS

- A. The contractor shall provide all necessary items for a complete operating system.
- B. Provide all electrical systems required by and in accordance with Division 26.
- C. Perform work for other divisions as required for electrical installations, or coordinate such work with other trades which includes but is not necessarily limited to:
 - 1. Division 1: Cutting and Patching, Temporary Controls, Submittals, Facility Start-up, Contract Close Out, Record Documents, etc.
 - 2. Division 2: Trenching, Backfilling, Compaction, Demolition, etc.
 - 3. Division 3: Concrete Formwork.
 - 4. Division 5: Metal Fabrications.
 - 5. Division 6: Rough Carpentry.
 - 6. Division 7: Joint Sealers and Fire Stopping
 - 7. Division 8: Electric Door Hardware and Access Doors
 - a. Deviation: Contractor is encouraged to coordinate and combine electrical access with mechanical access, and has the option to not add electrical access panels if acceptable coordination can be achieved.
 - 8. Division 9 - Painting: In addition to Division 9, paint electrical equipment factory applied paint surfaces damaged during installation with paint purchased from equipment manufacturer to match each damaged surface.
 - 9. Divisions 11 and 13: Laboratory Furniture, Electronic Systems, Intercoms, etc.
 - 10. Division 15 for motors, controls, accessories, and connections.
- D. Verify all dimensions by field measurements.
- E. Arrange for chases, sleeve, slots, and openings in other building components during progress of construction, to allow for electrical installations.
- F. Coordinate the installation of required supporting devices and sleeves to be set in poured-in-place concrete and other structural components, as they are constructed.
- G. Where mounting heights or locations are not detailed or dimensioned, install systems, materials, and equipment to provide the maximum headroom and working clearances possible, but not less than required by Code.
- H. Install systems, materials, and equipment to conform with approved submittal data, including coordination drawings and manufacturer's instructions, to greatest extent possible. Conform to arrangements indicated by the Contract Documents, recognizing that portions of the Work are shown only in diagrammatic form. Where coordination requirements conflict with individual system requirements, refer conflict to the Architect.
- I. Install systems, materials, and equipment level and plumb, parallel and perpendicular to other building systems and components, where installed exposed in finished spaces.

- J. Install electrical equipment to facilitate servicing, maintenance, and repair or replacement of equipment components. As much as practical, connect equipment for ease of disconnecting, with minimum of interference with other installations.
- K. Install J-boxes for all other equipment requiring access or maintenance, which are concealed behind surfaces so that these devices can be serviced from the access panels. Where practical, group J-boxes and equipment so that they can be accessed from the same panel or door. If additional panels are needed, panels must be submitted for approval.
- L. Cut, remove and legally dispose of selected electrical equipment, components, and materials, including but not limited to removal of electrical items indicated to be removed and items made obsolete by the new work.
- M. The A/E reserves the right to make relocations up to 6 feet of outlets, boxes, cabinets, lighting, etc. before finished rough-in at no cost to the Owner.
- N. Contractor shall notify design prime consultant and associated owner representative when he requests an inspection by the City Inspector.

3.02 COMMON REQUIREMENTS FOR ELECTRICAL INSTALLATIONS

- A. Comply with NECA 1.
- B. Measure indicated mounting heights to bottom of unit for suspended items and to center of unit for wall-mounting items.
- C. Headroom Maintenance: If mounting heights or other location criteria are not indicated, arrange and install components and equipment to provide maximum possible headroom consistent with these requirements.
- D. Equipment: Install to facilitate service, maintenance, and repair or replacement of components of both electrical equipment and other nearby installations. Connect in such a way as to facilitate future disconnecting with minimum interference with other items in the vicinity.
- E. Right of Way: Give to piping systems installed at a required slope.

3.03 SLEEVE INSTALLATION FOR ELECTRICAL PENETRATIONS

- A. Electrical penetrations occur when raceways, cables, wireways, cable trays, or busways penetrate concrete slabs, concrete or masonry walls, or fire-rated floor and wall assemblies.
- B. Concrete Slabs and Walls: Install sleeves for penetrations unless core-drilled holes or formed openings are used. Install sleeves during erection of slabs and walls.
- C. Use pipe sleeves unless penetration arrangement requires rectangular sleeved opening.
- D. Fire-Rated Assemblies: Install sleeves for penetrations of fire-rated floor and wall assemblies unless openings compatible with firestop system used are fabricated during construction of floor or wall.
- E. Cut sleeves to length for mounting flush with both surfaces of walls.
- F. Extend sleeves installed in floors 2 inches above finished floor level.
- G. Size pipe sleeves to provide 1/4-inch annular clear space between sleeve and raceway or cable, unless indicated otherwise.
- H. Seal space outside of sleeves with grout for penetrations of concrete and masonry
 - 1. Promptly pack grout solidly between sleeve and wall so no voids remain. Tool exposed surfaces smooth; protect grout while curing.

- I. Interior Penetrations of Non-Fire-Rated Walls and Floors: Seal annular space between sleeve and raceway or cable, using joint sealant appropriate for size, depth, and location of joint. Comply with requirements in Division 07 Section "Joint Sealants".
- J. Fire-Rated-Assembly Penetrations: Maintain indicated fire rating of walls, partitions, ceilings, and floors at raceway and cable penetrations. Install sleeves and seal raceway and cable penetration sleeves with firestop materials. Comply with requirements in Division 07 Section "Penetration Firestopping."
- K. Roof-Penetration Sleeves: Seal penetration of individual raceways and cables with flexible boot-type flashing units applied in coordination with roofing work.
- L. Aboveground, Exterior-Wall Penetrations: Seal penetrations using steel pipe sleeves and mechanical sleeve seals. Select sleeve size to allow for 1-inch annular clear space between pipe and sleeve for installing mechanical sleeve seals.
- M. Underground, Exterior-Wall Penetrations: Install cast-iron pipe sleeves. Size sleeves to allow for 1-inch annular clear space between raceway or cable and sleeve for installing mechanical sleeve seals.

3.04 SLEEVE-SEAL INSTALLATION

- A. Install to seal exterior wall penetrations.
- B. Use type and number of sealing elements recommended by manufacturer for raceway or cable material and size. Position raceway or cable in center of sleeve. Assemble mechanical sleeve seals and install in annular space between raceway or cable and sleeve. Tighten bolts against pressure plates that cause sealing elements to expand and make watertight seal.

3.05 FIRESTOPPING

- A. Apply firestopping to penetrations of fire-rated floor and wall assemblies for electrical installations to restore original fire-resistance rating of assembly. Firestopping materials and installation requirements are specified in Division 07 Section "Penetration Firestopping."

3.06 PRODUCT DELIVERY, STORAGE AND HANDLING

- A. Protection and Identification: Deliver products to project properly identified with names, model numbers, types, grades, compliance labels and similar information needed for distinct identification; adequately packaged or protected to prevent deterioration during shipment, storage and handling. Store in dry, well ventilated, indoor space, except where prepared and protected by manufacturer specifically for exterior storage.

3.07 TEMPORARY WIRING

- A. The electrical contractor shall arrange for and provide all necessary equipment, outlets, temporary lights, metering and communications as required during the construction period for temporary electrical service to the project.
- B. It shall be the responsibility of the electrical contractor to consult with all other trades on the project in order to determine the voltage of temporary electrical service required to operate the construction equipment to be employed and to provide such services to the project.
- C. It shall be the responsibility of the electrical contractor to make all arrangements for, and to furnish and install, any and all temporary wiring, switches, and structures which may be required to maintain service continuity during the entire construction period. Temporary power and lights shall be UL listed and shall include a ground wire, a guard and a proper means of support.

- D. All temporary installations shall be performed in accordance with the current edition of the National Electrical Code. All machinery and equipment powered by electricity shall have effective electrical equipment grounding provided with all electrical circuits.

3.08 UTILITIES

- A. This contractor shall examine the site and shall verify, to his own satisfaction, the location and elevation of all utilities, and shall adequately inform himself as to their relation to the work before entering into a contract.
- B. Existing utility lines shown within the scope of this project to be abandoned or removed shall be performed as directed by the Owner, and/or utility companies.
- C. Existing utility lines not shown on the drawings but encountered during construction shall be protected, relocated or capped as directed by the Owner, and/or utility companies. All precautions shall be exercised to prevent damage to existing lines not shown, but should work become necessary, it must be authorized prior to execution except in an emergency situation.
- D. Before beginning excavations of any nature whatsoever, the contractor shall make an attempt to locate all underground utilities of every nature occurring within the bounds of the area to be excavated. The contractor shall then proceed with caution in his excavation work so that no utility shall be damaged with a resultant loss of service.
- E. Should any damage result to any utility through the contractor's negligence or failure to comply with the above directive, he will be liable for such damage and for all expense incurred in the expeditious repair or replacement of such damaged utilities.
- F. Repair of damaged utilities shall be to a condition equal to or better than the adjacent undamaged portion of such utility and to the complete satisfaction of the Owner and/or utility companies.

3.09 EXCAVATION

- A. The contractor shall perform all excavation of every description and of whatever substances encountered, to the depths indicated and/or required for the installation of all portions of the utilities systems. All excavated materials not required for fill or backfill shall be removed. All excavation shall be made by open cut. The banks of trenches shall be kept as nearly vertical as practicable and where required shall be properly shored and braced. Trenches shall be at least 12" wider and not more than 16" wider than the outside diameter of the conduit, and shall be excavated true to line so that a clear space greater than 6" and less than 8" in width is provided on each side of the conduit or duct bank.
- B. Except at locations where the excavation of rock from bottom of trenches is required, care shall be taken not to excavate below the depths indicated. Where rock excavation is required, the rock shall be excavated to a minimum over-depth of 4" below the trench depths indicated on the drawings or as specified. The over-depth rock excavation shall be back-filled with loose, moist earth and thoroughly tamped.
- C. Whenever wet or otherwise unstable soil that is incapable of supporting the conduit duct bank, pole base or pad is encountered in the trench bottom, such soil shall be removed to a depth required. The trench bottom shall be filled with course sand, fine gravel, or other suitable material.
- D. Backfill with earth under pole bases, pads or other buried structures will not be permitted, and any unauthorized excess excavation below the levels indicated for foundation of such structures shall be filled with sand, gravel or concrete at the expense of the contractor.

- E. All grading in the vicinity of excavations shall be controlled to prevent surface ground water from flowing into the excavations. Any water accumulated in the excavations shall be removed by pumping or by other approved method. During excavation, material suitable for backfilling shall be stacked in an orderly manner a sufficient distance back from the edges of trenches to avoid overloading and to prevent slides or cave-ins.

3.10 BACK-FILLING

- A. Trenches shall not be back filled until all required tests are performed and until the utilities systems as installed conform to the requirements specified.
- B. Trenches shall be carefully back filled with the excavated materials approved for back filling. This material shall consist of earth, loam, sandy clay, sand and gravel, soft shale, or other approved materials, free from large clods of earth or stones, deposited in thoroughly and carefully tamped 6" layers, until the conduit has a cover as specified. Broken rock, broken concrete or pavement, and large boulders shall not be used as backfill material.
- C. Settling the backfill with water will be permissible and will be a requirement when so directed.
- D. Any trenches across roadways or other areas to be paved shall be back filled with K-Crete or approved equal (ashes combined with concrete) in such manner as to permit the rolling and compaction of the filled trench. Together with the adjoining earth, shall provide required bearing value so that paving of the area can proceed immediately after the backfilling is completed.

3.11 CLOSEOUT PROCEDURES

- A. General Coordination: Refer to Division 1 sections and individual specification sections for coordination of electrical closeout work with variable loads on electrical system. Coordinate taking of final photographs (if any) with electrical closeout, so that maximum detail of work as finally accepted is shown. Sequence closeout procedures properly, so that work will not be endangered or damaged, and so that every required performance will be fully tested and demonstrated.
- B. System Performance Test Runs: Coordinate test runs of electrical systems with test runs of equipment served thereby (heating, air conditioning, plumbing, etc.). Check each item in each system to determine that it is set for proper operation. With Owner's Representative and Engineer present, operate each system in test run of appropriate duration to demonstrate compliance with performance requirements. During or following test runs, make final corrections or adjustments of systems to refine and improve performances where possible, including noise and vibration reductions, elimination of hazards, better response of controls, signals and alarms, and similar system performance improvements. Provide testing or inspection devices as may be reasonably requested for Engineer's observation of actual system performances. Demonstrate that controls and items requiring service or maintenance are accessible.
- C. Cleaning and Lubrication: After final performance test run of each electrical system, clean system both externally and internally. Comply with manufacturer's instructions for lubrication of both power and hand-operated equipment, and remove excess lubrication. Touch-up minor damage to factory-painted finishes and other painting specified as electrical work; refinish work where damage is extensive.
- D. General Operating Instructions: In addition to specific training of Owner's operating personnel specified in individual Division 16 work sections, and in addition to preparation of written operating instructions and compiled maintenance manuals specified in Division-16 Sections and elsewhere in these specifications, provide general operating instructions for each

operational system and equipment item of electrical work. Coordinate instructions with instructions for mechanical work, elevators and other equipment where associated with electrical systems or equipment.

1. Describe each basic electrical system and functioning of its control system.
 2. Explain identification system, mimic diagrams, signals, actuators, sensors, alarms, telecommunication systems, and similar audio/visual provisions.
 3. Describe interfaces with mechanical equipment, including interlocks, sequencing, start-up, shut down, emergency, safety, system failure, security and similar provisions.
 4. Outline basic maintenance procedures and major equipment turnaround requirements, including adjustments to optimize output and efficiency of electrical system.
 5. Display and conduct "thumb-through" explanation of maintenance manuals, record drawings, spare part inventory, storage of extra materials, meter readings and similar service items.
- E. Construction Equipment: After completion of performance testing and Owner's operating instructions and demonstrations, remove installer's tools, test facilities, construction equipment and similar devices and materials used in execution of work but not incorporated in work.
- F. Security and Protection: During electrical work closeout phase, meet with Owner's operating representative frequently (daily where necessary) and agree upon status of operational responsibility for electrical systems (including securing provisions to prevent unauthorized operations, and including protective measures to ensure that systems are not neglected or misused.

PART 4- CONTINUED SYSTEM OPERATIONS

- A. Acceptance and Continued Services: Coordinate Owner's take-over of electrical systems with take-over of mechanical systems, including the provision of skilled electrical operating and maintenance personnel until time Owner's personnel take over operation of entire mechanical and electrical plant. Contractor shall continue consultation and services (beyond take-over date) for electrical systems, matching required continued services on associated mechanical systems and equipment.

END OF SECTION

SECTION 260519 - LOW-VOLTAGE ELECTRICAL POWER CONDUCTORS AND CABLES

PART 1 - GENERAL

1.01 RELATED DOCUMENTS

- A. Drawings and general provisions of the Contract, including General and Supplementary Conditions and Division 01 Specification Sections, apply to this Section.

1.02 SUMMARY

- A. This Section includes the following:
 - 1. Building wires and cables rated 600V and less.
 - 2. Connectors, splices, and terminations rated 600V and less.
 - 3. Sleeves and sleeve seals for cables.
- B. Related Sections include the following:
 - 1. Division 26 Section "Medium-Voltage Cables" for single-conductor and multi-conductor cables, cable splices, and terminations for electrical distribution systems with 2001 to 35,000V.
 - 2. Division 27 Section "Communications Horizontal Cabling" for cabling used for voice and data circuits.

1.03 DEFINITIONS

- A. EPDM: Ethylene-propylene-dieneterpolymer rubber.
- B. NBR: Acrylonitrile-butadiene rubber.

1.04 SUBMITTALS

- A. Product Data: For each type of product indicated.
- B. Qualification Data: For testing agency.
- C. Field quality-control test reports.

1.05 QUALITY ASSURANCE

- A. Testing Agency Qualifications: An independent agency, with the experience and capability to conduct the testing indicated, that is a member company of the InterNational Electrical Testing Association or is a nationally recognized testing laboratory (NRTL) as defined by OSHA in 29 CFR 1910.7, and that is acceptable to authorities having jurisdiction.
 - 1. Testing Agency's Field Supervisor: Person currently certified by the InterNational Electrical Testing Association or the National Institute for Certification in Engineering Technologies to supervise on-site testing specified in Part 3.
- B. Electrical Components, Devices, and Accessories: Listed and labeled as defined in NFPA 70, Article 100, by a testing agency acceptable to authorities having jurisdiction, and marked for intended use.
- C. Comply with NFPA 70.
- D. UL Compliance: Provide components which are listed and labeled by UL under the following standards.
 - 1. UL Std. 83 - Thermoplastic-Insulated Wires and Cables.

2. UL Std. 4 - Armored Cable
 3. UL Std. 1569 - Metal-Clad Cables
 4. UL Std. 486A - Wire Connectors and Soldering Lugs for Use with Copper Conductors.
 5. UL 13 - Power limited circuit cables.
 6. UL 1666 - Test for flame propagation height of electrical and optical-fiber cables installed vertically in shafts.
 7. UL 910 - Test for flame propagation and smoke density values for and optical fiber cables used in spaces environmental air.
 8. UL 1685 - Vertical tray fire propagation and smoke release test for and optical fiber cables.
- E. NEMA WC-5: Thermoplastic-insulated wire and cable for the transmission and distribution of electrical energy.
- F. Federal Specifications
1. J-C-30B (1) cable and wire, electrical (power, fixed installation).

1.06 COORDINATION

- A. Set sleeves in cast-in-place concrete, masonry walls, and other structural components as they are constructed.

PART 2 - PRODUCTS

2.01 CONDUCTORS AND CABLES

- A. Manufacturers, 600 Volt or Less Wire and Cable: Subject to compliance with requirements, provide products by one of the following:
1. Essex.
 2. General Wire.
 3. South wire.
- B. Manufacturers, Low Voltage Wire (300V and under): Subject to compliance with requirements, provide products by one of the following
1. Alpha.
 2. Belden.
 3. West Penn.
- C. Copper Conductors: Comply with NEMA WC 70.
- D. Conductor Insulation: Comply with NEMA WC 70 for Types THW, THHN-THWN, XHHW, UF, USE and SO.
- E. Multi-conductor Cable: Comply with NEMA WC 70 for armed cable, Type AC, metal clad cable, Type MC, mineral-insulated, sheathed cable, Type MI with ground wire.

2.02 CONNECTORS AND SPLICES

- A. Available Manufacturers: Subject to compliance with requirements, manufacturers offering products that may be incorporated into the Work include, but are not limited to, the following:
- B. Manufacturers: Subject to compliance with requirements, provide products by one of the following:
1. AFC Cable Systems, Inc.
 2. Hubbell Power Systems, Inc.
 3. O-Z/Gedney; EGS Electrical Group LLC.

4. 3M; Electrical Products Division.
 5. Tyco Electronics Corp.
- C. Description: Factory-fabricated connectors and splices of size, ampacity rating, material, type, and class for application and service indicated.

2.03 SLEEVES FOR CABLES

- A. Steel Pipe Sleeves: ASTM A 53/A 53M, Type E, Grade B, Schedule 40, galvanized steel, plain ends.
- B. Cast-Iron Pipe Sleeves: Cast or fabricated "wall pipe," equivalent to ductile-iron pressure pipe, with plain ends and integral water stop, unless otherwise indicated.
- C. Sleeves for Rectangular Openings: Galvanized sheet steel with minimum 0.052- or 0.138-inch thickness as indicated and of length to suit application.
- D. Coordinate sleeve selection and application with selection and application of firestopping specified in Division 07 Section "Penetration Firestopping."

2.04 SLEEVE SEALS

- A. Manufacturers: Subject to compliance with requirements, provide products by one of the following:
- B. Basis-of-Design Product: Subject to compliance with requirements, provide a comparable product by one of the following:
 1. Advance Products & Systems, Inc.
 2. Calpico, Inc.
 3. Metraflex Co.
 4. Pipeline Seal and Insulator, Inc.
- C. Description: Modular sealing device, designed for field assembly, to fill annular space between sleeve and cable.

PART 3 - EXECUTION

3.01 CONDUCTOR MATERIAL APPLICATIONS

- A. Feeders: Copper. Solid for No. 10 AWG and smaller; stranded for No. 8 AWG and larger.
- B. Branch Circuits: Copper. Solid for No. 10 AWG and smaller; stranded for No. 8 AWG and larger.

3.02 INSTALLATION OF CONDUCTORS AND CABLES

- A. Conceal cables in finished walls, ceilings, and floors, unless otherwise indicated.
- B. Use manufacturer-approved pulling compound or lubricant where necessary; compound used must not deteriorate conductor or insulation. Do not exceed manufacturer's recommended maximum pulling tensions and sidewall pressure values.
- C. Use pulling means, including fish tape, cable, rope, and basket-weave wire/cable grips, that will not damage cables or raceway.
- D. Install exposed cables parallel and perpendicular to surfaces of exposed structural members, and follow surface contours where possible.
- E. Support cables according to Division 26 Section "Hangers and Supports for Electrical Systems."

- F. Identify and color-code conductors and cables according to Division 26 Section "Identification for Electrical Systems."
- G. All wire shall be installed in conduit or raceways.
- H. All circuits shall have a hot, neutral and green ground wire unless otherwise indicated.
- I. Provide #12 conductors and #12 grounds minimum to all 15 and 20 amp devices unless otherwise indicated.
- J. Provide #10 conductors and #10 grounds minimum to all 30 amp devices unless otherwise indicated.
- K. Provide #10 minimum conductors for 120/208V 20 amp circuits for which the distance from the panelboard to the first device is greater than 100 feet.
- L. Provide #10 minimum conductors for 277/480V 20 amp circuits for which the distance from the panelboard to the first device is greater than 200 feet.
- M. Do not install wires in conduit until entire system of conduit and outlet boxes is permanently in place.
- N. Exercise care when installing wire in conduit so as to prevent injury to the conductor insulation. Mechanical means of pulling shall not be used unless approved. Conductors shall be pulled using UL non-flammable listed lubricant when necessary.
- O. Whenever wiring leaves the conduit and terminates at a terminal board, the wiring shall be formed and laced with plastic wire ties.
- P. In the event circuits feed through outlet boxes, provide splice and pigtail for device connection, with sufficient slack to pull splice out of box at least 6 inches (for inspection).
- Q. Coordinate cable installation with other Work.
- R. Pull conductors simultaneously where more than one is being installed in same raceway.
- S. Use pulling means including, fish tape, cable, rope, and basket weave wire/cable grips which will not damage cables or raceways. Do not use rope hitches for pulling attachment to wire or cable.
- T. Keep conductor splices to a minimum.
- U. Install splice and tap connectors which possess equivalent or better mechanical strength and insulation rating than conductors being spliced.
- V. Use splice and tap connectors which are compatible with conductor material.
- W. Provide adequate length of conductors within electrical enclosures and train the conductors to terminal points with no excess. Bundle multiple conductors, with conductors larger than no.10 AWG cabled in individual circuits. Make terminations so there is no bare conductor at the terminal.
- X. Home Runs: except where specifically indicated, provide lighting branch circuit home runs with not more than three different line conductors and a common neutral in a single raceway for 4-wire, 3-phase systems.
- Y. Conductors may be run in parallel in sizes 1/0 through 750 MCM where indicated and provided that all conductors of each phase are the same length and so arranged and terminated as to ensure equal division of the current between all paralleled phase conductors.
- Z. Feeders shall be installed in continuous pieces without splice.
Install a separate neutral for each circuit which serves GFCI or isolated ground receptacles.

Each circuit originating from a GFCI type circuit breaker shall also have a separate neutral.

- AA. Where specifically indicated, for receptacle branch circuits, provide a separate neutral conductor for each line conductor.
- BB. Each circuit serving receptacles where data terminals are used shall have separate neutral.

3.03 CONNECTIONS

- A. Tighten electrical connectors and terminals according to manufacturer's published torque-tightening values. If manufacturer's torque values are not indicated, use those specified in UL 486A and UL 486B.
- B. Make splices and taps that are compatible with conductor material and that possess equivalent or better mechanical strength and insulation ratings than un-spliced conductors.
 - 1. Use oxide inhibitor in each splice and tap conductor for aluminum conductors.
- C. Wiring at Outlets: Install conductor at each outlet, with at least 6 inches of slack.

3.04 SLEEVE INSTALLATION FOR ELECTRICAL PENETRATIONS

- A. Coordinate sleeve selection and application with selection and application of firestopping specified in Division 07 Section "Penetration Firestopping."
- B. Concrete Slabs and Walls: Install sleeves for penetrations unless core-drilled holes or formed openings are used. Install sleeves during erection of slabs and walls.
- C. Use pipe sleeves unless penetration arrangement requires rectangular sleeved opening.
- D. Rectangular Sleeve Minimum Metal Thickness:
 - 1. For sleeve rectangle perimeter less than 50 inches and no side greater than 16 inches, thickness shall be 0.052 inch.
 - 2. For sleeve rectangle perimeter equal to, or greater than, 50 inches and 1 or more sides equal to, or greater than, 16 inches, thickness shall be 0.138 inch.
- E. Fire-Rated Assemblies: Install sleeves for penetrations of fire-rated floor and wall assemblies unless openings compatible with firestop system used are fabricated during construction of floor or wall.
- F. Edit first paragraph below as required for 2-inch (50-mm) extension above floor.
- G. Cut sleeves to length for mounting flush with both wall surfaces.
- H. Extend sleeves installed in floors 2 inches above finished floor level.
- I. Edit paragraph below as required for Project design conditions and seismic-criteria status.
- J. Size pipe sleeves to provide 1/4-inch annular clear space between sleeve and cable unless sleeve seal is to be installed.
- K. Retain first paragraph below if external sealing is required.
- L. Seal space outside of sleeves with grout for penetrations of concrete and masonry and with approved joint compound for gypsum board assemblies.
- M. Interior Penetrations of Non-Fire-Rated Walls and Floors: Seal annular space between sleeve and cable, using joint sealant appropriate for size, depth, and location of joint according to Division 07 Section "Joint Sealants."

- N. Fire-Rated-Assembly Penetrations: Maintain indicated fire rating of walls, partitions, ceilings, and floors at cable penetrations. Install sleeves and seal with firestop materials according to Division 07 Section "Penetration Firestopping."
- O. Roof-Penetration Sleeves: Seal penetration of individual cables with flexible boot-type flashing units applied in coordination with roofing work.
- P. Aboveground Exterior-Wall Penetrations: Seal penetrations using sleeves and mechanical sleeve seals. Size sleeves to allow for 1-inch annular clear space between pipe and sleeve for installing mechanical sleeve seals.
- Q. Underground Exterior-Wall Penetrations: Install cast-iron "wall pipes" for sleeves. Size sleeves to allow for 1-inch annular clear space between cable and sleeve for installing mechanical sleeve seals.

3.05 SLEEVE-SEAL INSTALLATION

- A. Install to seal underground exterior-wall penetrations.
- B. Use type and number of sealing elements recommended by manufacturer for cable material and size. Position cable in center of sleeve. Assemble mechanical sleeve seals and install in annular space between cable and sleeve. Tighten bolts against pressure plates that cause sealing elements to expand and make watertight seal.

3.06 FIRESTOPPING

- A. Apply firestopping to electrical penetrations of fire-rated floor and wall assemblies to restore original fire-resistance rating of assembly according to Division 07 Section "Penetration Firestopping."

3.07 FIELD QUALITY CONTROL

- A. Testing Agency: Engage a qualified testing agency to perform tests and inspections and prepare test reports.
- B. Perform tests and inspections and prepare test reports.
- C. Tests and Inspections:
 - 1. Performing NETA tests on all conductors and cables can be expensive. Consider limiting testing to a certain group of conductors, such as service entrance and feeder conductors, or to those conductors feeding critical equipment and services. To require all conductors and cables to be tested, delete option in first subparagraph below and delete associated subparagraph.
 - 2. After installing conductors and cables and before electrical circuitry has been energized, test service entrance and feeder conductors, and conductors feeding the following critical equipment and services for compliance with requirements.
 - 3. Perform each visual and mechanical inspection and electrical test stated in NETA Acceptance Testing Specification. Certify compliance with test parameters.
 - 4. Consider the cost and benefit of infrared scanning of cable and conductor splices before retaining subparagraph and associated subparagraphs below.
 - 5. Infrared Scanning: After Substantial Completion, but not more than 60 days after Final Acceptance, perform an infrared scan of each splice in cables and conductors No. 3 AWG and larger. Remove box and equipment covers so splices are accessible to portable scanner.
 - a. Follow-up Infrared Scanning: Perform an additional follow-up infrared scan of each splice 11 months after date of Substantial Completion.

- b. Instrument: Use an infrared scanning device designed to measure temperature or to detect significant deviations from normal values. Provide calibration record for device.
 - c. Record of Infrared Scanning: Prepare a certified report that identifies splices checked and that describes scanning results. Include notation of deficiencies detected, remedial action taken, and observations after remedial action.
- D. Test Reports: Prepare a written report to record the following:
- 1. Test procedures used.
 - 2. Test results that comply with requirements.
 - 3. Test results that do not comply with requirements and corrective action taken to achieve compliance with requirements.
- E. Remove and replace malfunctioning units and retest as specified above.

END OF SECTION

SECTION 260526 - GROUNDING AND BONDING FOR ELECTRICAL SYSTEMS

PART 1 - GENERAL

1.01 RELATED DOCUMENTS

- A. Drawings and general provisions of the Contract, including General and Supplementary Conditions and Division 01 Specification Sections, apply to this Section.

1.02 SUMMARY

- A. This Section includes methods and materials for grounding systems and equipment, plus the following special applications:
 - 1. Underground distribution grounding.
 - 2. Common ground bonding with lightning protection system.

1.03 SUBMITTALS

- A. Product Data: For each type of product indicated.
- B. Other Informational Submittals: Plans showing dimensioned as-built locations of grounding features specified in Part 3 "Field Quality Control" Article, including the following:
 - 1. Test wells.
 - 2. Ground rods.
 - 3. Ground rings.
 - 4. Grounding arrangements and connections for separately derived systems.
 - 5. Grounding for sensitive electronic equipment.
- C. Qualification Data: For testing agency and testing agency's field supervisor.
- D. Field quality-control test reports.
- E. Operation and Maintenance Data: For grounding to include the following in emergency, operation, and maintenance manuals:
 - 1. Instructions for periodic testing and inspection of grounding features at ground rings grounding connections for separately derived systems based on NFPA 70B.
 - a. Tests shall be to determine if ground resistance or impedance values remain within specified maximums, and instructions shall recommend corrective action if they do not.
 - b. Include recommended testing intervals.

1.04 QUALITY ASSURANCE

- A. Testing Agency Qualifications: An independent agency, with the experience and capability to conduct the testing indicated, that is a member company of the InterNational Electrical Testing Association or is a nationally recognized testing laboratory (NRTL) as defined by OSHA in 29 CFR 1910.7, and that is acceptable to authorities having jurisdiction.
 - 1. Testing Agency's Field Supervisor: Person currently certified by the InterNational Electrical Testing Association to supervise on-site testing specified in Part 3.
- B. Electrical Components, Devices, and Accessories: Listed and labeled as defined in NFPA 70, Article 100, by a testing agency acceptable to authorities having jurisdiction, and marked for intended use.
- C. Comply with UL 467 for grounding and bonding materials and equipment.

PART 2 - PRODUCTS

2.01 GROUNDING AND BONDING FOR ELECTRICAL SYSTEMS

- A. Acceptable Manufacturers: Copper weld, Cad weld, Bundy

2.02 CONDUCTORS

- A. Insulated Conductors: Copper wire or cable insulated for 600 V unless otherwise required by applicable Code or authorities having jurisdiction.
- B. Bare Copper Conductors:
 - 1. Solid Conductors: ASTM B 3.
 - 2. Stranded Conductors: ASTM B 8.
 - 3. Tinned Conductors: ASTM B 33.
 - 4. Bonding Cable: 28 kcmil, 14 strands of No. 17 AWG conductor and 1/4 inch in diameter.
 - 5. Bonding Conductor: No. 4 or No. 6 AWG, stranded conductor.
 - 6. Bonding Jumper: Copper tape, braided conductors, terminated with copper ferrules; 1-5/8 inches wide and 1/16 inch thick.
 - 7. Tinned Bonding Jumper: Tinned-copper tape, braided conductors, terminated with copper ferrules; 1-5/8 inches wide and 1/16 inch thick.
- C. Bare Grounding Conductor and Conductor Protector for Wood Poles:
 - 1. No. 4 AWG minimum, soft-drawn copper.
 - 2. Conductor Protector: Half-round PVC or wood molding. If wood, use pressure-treated fir or cypress or cedar.
- D. Grounding Bus: Rectangular bars of annealed copper, 1/4 by 2 inches in cross section, unless otherwise indicated; with insulators.

2.03 CONNECTORS

- A. Listed and labeled by a nationally recognized testing laboratory acceptable to authorities having jurisdiction for applications in which used, and for specific types, sizes, and combinations of conductors and other items connected.
- B. Bolted Connectors for Conductors and Pipes: Copper or copper alloy, bolted pressure-type, with at least two bolts.
 - 1. Pipe Connectors: Clamp type, sized for pipe.
- C. Welded Connectors: Exothermic-welding kits of types recommended by kit manufacturer for materials being joined and installation conditions.

2.04 GROUNDING ELECTRODES

- A. Ground Rods: Copper-clad steel; 3/4 inch by 10 feet in diameter.
- B. Chemical-Enhanced Grounding Electrodes: Copper tube, straight or L-shaped, charged with nonhazardous electrolytic chemical salts.
 - 1. Termination: Factory-attached No. 4/0 AWG bare conductor at least 48 inches long.
 - 2. Backfill Material: Electrode manufacturers recommended material.

PART 3 - EXECUTION

3.01 APPLICATIONS

- A. Conductors: Install solid conductor for No. 8 AWG and smaller, and stranded conductors for No. 6 AWG and larger, unless otherwise indicated.
- B. Underground Grounding Conductors: Install bare tinned copper conductor, No. 2/0 AWG minimum.
 - 1. Bury at least 24 inches below grade.
 - 2. Duct-Bank Grounding Conductor: Bury 12 inches above duct bank when indicated as part of duct-bank installation.
- C. Isolated Grounding Conductors: Green-colored insulation with continuous yellow stripe. On feeders with isolated ground, identify grounding conductor where visible to normal inspection, with alternating bands of green and yellow tape, with at least three bands of green and two bands of yellow.
- D. Grounding Bus: Install in electrical and telephone equipment rooms, in rooms housing service equipment, and elsewhere as indicated.
 - 1. Install bus on insulated spacers 1 inch, minimum, from wall 6 inches above finished floor, unless otherwise indicated.
 - 2. Where indicated on both sides of doorways, route bus up to top of door frame, across top of doorway, down to specified height above floor, and connect to horizontal bus.
- E. Conductor Terminations and Connections:
 - 1. Pipe and Equipment Grounding Conductor Terminations: Bolted connectors.
 - 2. Underground Connections: Welded connectors except at test wells and as otherwise indicated.
 - 3. Connections to Ground Rods at Test Wells: Bolted connectors.
 - 4. Connections to Structural Steel: Welded connectors.

3.02 GROUNDING UNDERGROUND DISTRIBUTION SYSTEM COMPONENTS

- A. Comply with IEEE C2 grounding requirements.
- B. Grounding Manholes and Handholes: Install a driven ground rod through manhole or handhole floor, close to wall, and set rod depth so 4 inches will extend above finished floor. If necessary, install ground rod before manhole is placed and provide No. 1/0 AWG bare, tinned-copper conductor from ground rod into manhole through a waterproof sleeve in manhole wall. Protect ground rods passing through concrete floor with a double wrapping of pressure-sensitive insulating tape or heat-shrunk insulating sleeve from 2 inches above to 6 inches below concrete. Seal floor opening with waterproof, non-shrink grout.
- C. Grounding Connections to Manhole Components: Bond exposed-metal parts such as inserts, cable racks, pulling irons, ladders, and cable shields within each manhole or handhole, to ground rod or grounding conductor. Make connections with No. 4 AWG minimum, stranded, hard-drawn copper bonding conductor. Train conductors level or plumb around corners and fasten to manhole walls. Connect to cable armor and cable shields as recommended by manufacturer of splicing and termination kits.
- D. Pad-Mounted Transformers and Switches: Install two ground rods and ground ring around the pad. Ground pad-mounted equipment and noncurrent-carrying metal items associated with substations by connecting them to underground cable and grounding electrodes. Install tinned-

copper conductor not less than No. 2 AWG for ground ring and for taps to equipment grounding terminals. Bury ground ring not less than 6 inches from the foundation.

3.03 EQUIPMENT GROUNDING

- A. Install insulated equipment grounding conductors with all feeders and branch circuits.
- B. Install insulated equipment grounding conductors with the following items, in addition to those required by NFPA 70:
 - 1. Feeders and branch circuits.
 - 2. Lighting circuits.
 - 3. Receptacle circuits.
 - 4. Single-phase motor and appliance branch circuits.
 - 5. Three-phase motor and appliance branch circuits.
 - 6. Flexible raceway runs.
 - 7. Armored and metal-clad cable runs.
 - 8. Busway Supply Circuits: Install insulated equipment grounding conductor from grounding bus in the switchgear, switchboard, or distribution panel to equipment grounding bar terminal on busway.
 - 9. Computer and Rack-Mounted Electronic Equipment Circuits: Install insulated equipment grounding conductor in branch-circuit runs from equipment-area power panels and power-distribution units.
- C. Air-Duct Equipment Circuits: Install insulated equipment grounding conductor to duct-mounted electrical devices operating at 120 V and more, including air cleaners, heaters, dampers, humidifiers, and other duct electrical equipment. Bond conductor to each unit and to air duct and connected metallic piping.
- D. Water Heater, Heat-Tracing, and Anti-frost Heating Cables: Install a separate insulated equipment grounding conductor to each electric water heater and heat-tracing cable. Bond conductor to heater units, piping, connected equipment, and components.
- E. Isolated Grounding Receptacle Circuits: Install an insulated equipment grounding conductor connected to the receptacle grounding terminal. Isolate conductor from raceway and from panelboard grounding terminals. Terminate at equipment grounding conductor terminal of the applicable derived system or service, unless otherwise indicated.
- F. Isolated Equipment Enclosure Circuits: For designated equipment supplied by a branch circuit or feeder, isolate equipment enclosure from supply circuit raceway with a nonmetallic raceway fitting listed for the purpose. Install fitting where raceway enters enclosure, and install a separate insulated equipment grounding conductor. Isolate conductor from raceway and from panelboard grounding terminals. Terminate at equipment grounding conductor terminal of the applicable derived system or service, unless otherwise indicated.
- G. Signal and Communication Equipment: For telephone, alarm, voice and data, and other communication equipment, provide No. 4 AWG minimum insulated grounding conductor in raceway from grounding electrode system to each service location, terminal cabinet, wiring closet, and central equipment location.
 - 1. Service and Central Equipment Locations and Wiring Closets: Terminate grounding conductor on a 1/4-by-2-by-12-inch grounding bus.
 - 2. Terminal Cabinets: Terminate grounding conductor on cabinet grounding terminal.
- H. Metal Poles Supporting Outdoor Lighting Fixtures: Install grounding electrode and a separate insulated equipment grounding conductor in addition to grounding conductor installed with branch-circuit conductors.

3.04 INSTALLATION

- A. Grounding Conductors: Route along shortest and straightest paths possible, unless otherwise indicated or required by Code. Avoid obstructing access or placing conductors where they may be subjected to strain, impact, or damage.
- B. Common Ground Bonding with Lightning Protection System: Comply with NFPA 780 and UL 96 when interconnecting with lightning protection system. Bond electrical power system ground directly to lightning protection system grounding conductor at closest point to electrical service grounding electrode. Use bonding conductor sized same as system grounding electrode conductor, and install in conduit.
- C. Ground Rods: Drive rods until tops are 2 inches below finished floor or final grade, unless otherwise indicated.
 - 1. Interconnect ground rods with grounding electrode conductor below grade and as otherwise indicated. Make connections without exposing steel or damaging coating, if any.
 - 2. For grounding electrode system, install at least three rods spaced at least one-rod length from each other and located at least the same distance from other grounding electrodes, and connect to the service grounding electrode conductor.
- D. Test Wells: Ground rod driven through drilled hole in bottom of handhole. Handholes are specified in Division 26 Section "Underground Ducts and Raceways for Electrical Systems," and shall be at least 12 inches deep, with cover.
 - 1. Test Wells: Install at least one test well for each service, unless otherwise indicated. Install at the ground rod electrically closest to service entrance. Set top of test well flush with finished grade or floor.
- E. Bonding Straps and Jumpers: Install in locations accessible for inspection and maintenance, except where routed through short lengths of conduit.
 - 1. Bonding to Structure: Bond straps directly to basic structure, taking care not to penetrate any adjacent parts.
 - 2. Bonding to Equipment Mounted on Vibration Isolation Hangers and Supports: Install so vibration is not transmitted to rigidly mounted equipment.
 - 3. Use exothermic-welded connectors for outdoor locations, but if a disconnect-type connection is required, use a bolted clamp.
- F. Grounding and Bonding for Piping:
 - 1. Metal Water Service Pipe: Install insulated copper grounding conductors, in conduit, from building's main service equipment, or grounding bus, to main metal water service entrances to building. Connect grounding conductors to main metal water service pipes, using a bolted clamp connector or by bolting a lug-type connector to a pipe flange, using one of the lug bolts of the flange. Where a dielectric main water fitting is installed, connect grounding conductor on street side of fitting. Bond metal grounding conductor conduit or sleeve to conductor at each end.
 - 2. Water Meter Piping: Use braided-type bonding jumpers to electrically bypass water meters. Connect to pipe with a bolted connector.
 - 3. Bond each aboveground portion of gas piping system downstream from equipment shutoff valve.
- G. Bonding Interior Metal Ducts: Bond metal air ducts to equipment grounding conductors of associated fans, blowers, electric heaters, and air cleaners. Install bonding jumper to bond across flexible duct connections to achieve continuity.
- H. Grounding for Steel Building Structure: Install a driven ground rod at base of each corner column and at intermediate exterior columns at distances not more than 60 feet apart.

- I. Ground Ring: Install a grounding conductor, electrically connected to each building structure ground rod and to each indicated item, extending around the perimeter of[building].
 1. Install tinned-copper conductor not less than No. 2/0 AWG for ground ring and for taps to building steel.
 2. Bury ground ring not less than 24 inches from building foundation.

3.05 FIELD QUALITY CONTROL

- A. Testing Agency: Owner will engage a qualified testing and inspecting agency to perform field tests and inspections and prepare test reports.
- B. Testing Agency: Engage a qualified testing and inspecting agency to perform the following field tests and inspections and prepare test reports:
- C. Perform the following tests and inspections and prepare test reports:
 1. After installing grounding system but before permanent electrical circuits have been energized, test for compliance with requirements.
 2. Test completed grounding system at each location where a maximum ground-resistance level is specified, at service disconnect enclosure grounding terminal and at individual ground rods. Make tests at ground rods before any conductors are connected.
 - a. Measure ground resistance not less than two full days after last trace of precipitation and without soil being moistened by any means other than natural drainage or seepage and without chemical treatment or other artificial means of reducing natural ground resistance.
 - b. Perform tests by fall-of-potential method according to IEEE 81.
 3. Prepare dimensioned drawings locating each test well, ground rod and ground rod assembly, and other grounding electrodes. Identify each by letter in alphabetical order, and key to the record of tests and observations. Include the number of rods driven and their depth at each location, and include observations of weather and other phenomena that may affect test results. Describe measures taken to improve test results.
- D. Report measured ground resistances that exceed the following values:
 1. Power and Lighting Equipment or System with Capacity More Than 1000 kVA: 5 ohms.
 2. Power Distribution Units or Panelboards Serving Electronic Equipment: 3 ohm(s).
 3. Substations and Pad-Mounted Equipment: 5 ohms.
 4. Manhole Grounds: 10 ohms.
- E. Excessive Ground Resistance: If resistance to ground exceeds specified values, notify Architect promptly and include recommendations to reduce ground resistance.

END OF SECTION

SECTION 260529 - HANGERS AND SUPPORTS FOR ELECTRICAL SYSTEMS

PART 1 –GENERAL

1.01 RELATED DOCUMENTS

- A. Drawings and general provisions of the Contract, including General and Supplementary Conditions and Division 01 Specification Sections, apply to this Section.

1.02 SUMMARY

- A. This Section includes the following:
 - 1. Hangers and supports for electrical equipment and systems.
 - 2. Construction requirements for concrete bases.

1.03 DEFINITIONS

- A. EMT: Electrical metallic tubing.
- B. IMC: Intermediate metal conduit.
- C. RMC: Rigid metal conduit.

1.04 PERFORMANCE REQUIREMENTS

- A. Delegated Design: Design supports for multiple raceways, including comprehensive engineering analysis by a qualified professional engineer, using performance requirements and design criteria indicated.
- B. Design supports for multiple raceways capable of supporting combined weight of supported systems and its contents.
- C. Design equipment supports capable of supporting combined operating weight of supported equipment and connected systems and components.
- D. Rated Strength: Adequate in tension, shear, and pullout force to resist maximum loads calculated or imposed for this Project, with a minimum structural safety factor of five times the applied force.

1.05 SUBMITTALS

- A. Product Data: For the following:
 - 1. Steel slotted support systems.
 - 2. Nonmetallic slotted support systems.
- B. Shop Drawings: Show fabrication and installation details and include calculations for the following:
 - 1. Trapeze hangers. Include Product Data for components.
 - 2. Steel slotted channel systems. Include Product Data for components.
 - 3. Nonmetallic slotted channel systems. Include Product Data for components.
 - 4. Equipment supports.

1.06 QUALITY ASSURANCE

- A. Welding: Qualify procedures and personnel according to AWS D1.1/D1.1M, "Structural Welding Code - Steel."

- B. Comply with NFPA 70.

1.07 COORDINATION

- A. Coordinate size and location of concrete bases. Cast anchor-bolt inserts into bases. Concrete, reinforcement, and formwork requirements are specified in Division 03.
- B. Coordinate installation of roof curbs, equipment supports, and roof penetrations. These items are specified in Division 07 Section "Roof Accessories."

PART 2 - PRODUCTS

2.01 SUPPORT, ANCHORAGE, AND ATTACHMENT COMPONENTS

- A. Steel Slotted Support Systems: Comply with MFMA-4, factory-fabricated components for field assembly.
 - 1. Available Manufacturers: Subject to compliance with requirements, manufacturers offering products that may be incorporated into the Work include, but are not limited to, the following:
 - 2. Manufacturers: Subject to compliance with requirements, provide products by one of the following:
 - a. Allied Tube & Conduit.
 - b. Cooper B-Line, Inc.; a division of Cooper Industries.
 - c. ERICO International Corporation.
 - d. Thomas & Betts Corporation.
 - e. Unistrut; Tyco International, Ltd.
 - 3. Metallic Coatings: Hot-dip galvanized after fabrication and applied according to MFMA-4.
 - 4. Nonmetallic Coatings: Manufacturer's standard PVC, polyurethane, or polyester coating applied according to MFMA-4.
 - 5. Painted Coatings: Manufacturer's standard painted coating applied according to MFMA-4.
 - 6. Channel Dimensions: Selected for applicable load criteria.
- B. Nonmetallic Slotted Support Systems: Structural-grade, factory-formed, glass-fiber-resin channels and angles with 9/16-inch diameter holes at a maximum of 8 inches o.c., in at least 1 surface.
 - 1. Available Manufacturers: Subject to compliance with requirements, manufacturers offering products that may be incorporated into the Work include, but are not limited to, the following:
 - 2. Manufacturers: Subject to compliance with requirements, provide products by one of the following:
 - a. Allied Tube & Conduit.
 - b. Cooper B-Line, Inc.; a division of Cooper Industries.
 - c. Fabco Plastics Wholesale Limited.
 - 3. Fittings and Accessories: Products of channel and angle manufacturer and designed for use with those items.
 - 4. Fitting and Accessory Materials: Same as channels and angles except metal items may be stainless steel.
 - 5. Rated Strength: Selected to suit applicable load criteria.
- C. Raceway and Cable Supports: As described in NECA 1 and NECA 101.

- D. Conduit and Cable Support Devices: Steel and malleable-iron hangers, clamps, and associated fittings, designed for types and sizes of raceway or cable to be supported.
- E. Support for Conductors in Vertical Conduit: Factory-fabricated assembly consisting of threaded body and insulating wedging plug or plugs for non-armored electrical conductors or cables in riser conduits. Plugs shall have number, size, and shape of conductor gripping pieces as required to suit individual conductors or cables supported. Body shall be malleable iron.
- F. Structural Steel for Fabricated Supports and Restraints: ASTM A 36/A 36M, steel plates, shapes, and bars; black and galvanized.
- G. Mounting, Anchoring, and Attachment Components: Items for fastening electrical items or their supports to building surfaces include the following:
 - 1. Powder-Actuated Fasteners: Threaded-steel stud, for use in hardened portland cement concrete, steel, or wood, with tension, shear, and pullout capacities appropriate for supported loads and building materials where used.
 - a. Available Manufacturers: Subject to compliance with requirements, manufacturers offering products that may be incorporated into the Work include, but are not limited to, the following:
 - b. Manufacturers: Subject to compliance with requirements, provide products by one of the following:
 - (1) Hilti Inc.
 - (2) ITW Ramset/Red Head; a division of Illinois Tool Works, Inc.
 - (3) MKT Fastening, LLC.
 - (4) Simpson Strong-Tie Co., Inc.; Masterset Fastening Systems Unit.
 - 2. Mechanical-Expansion Anchors: Insert-wedge-type, steel, for use in hardened portland cement concrete with tension, shear, and pullout capacities appropriate for supported loads and building materials in which used.
 - a. Available Manufacturers: Subject to compliance with requirements, manufacturers offering products that may be incorporated into the Work include, but are not limited to, the following:
 - b. Manufacturers: Subject to compliance with requirements, provide products by one of the following:
 - (1) Cooper B-Line, Inc.; a division of Cooper Industries.
 - (2) Empire Tool and Manufacturing Co., Inc.
 - (3) Hilti Inc.
 - (4) ITW Ramset/Red Head; a division of Illinois Tool Works, Inc.
 - (5) MKT Fastening, LLC.
 - 3. Concrete Inserts: Steel or malleable-iron, slotted support system units similar to MSS Type 18; complying with MFMA-4 or MSS SP-58.
 - 4. Clamps for Attachment to Steel Structural Elements: MSS SP-58, type suitable for attached structural element.
 - 5. Through Bolts: Structural type, hex head, and high strength. Comply with ASTM A 325.
 - 6. Toggle Bolts: All-steel springhead type.
 - 7. Hanger Rods: Threaded steel.

2.02 FABRICATED METAL EQUIPMENT SUPPORT ASSEMBLIES

- A. Description: Welded or bolted, structural-steel shapes, shop or field fabricated to fit dimensions of supported equipment.

- B. Materials: Comply with requirements in Division 05 Section "Metal Fabrications" for steel shapes and plates.

PART 3 - EXECUTION

3.01 APPLICATION

- A. Comply with NECA 1 and NECA 101 for application of hangers and supports for electrical equipment and systems except if requirements in this Section are stricter.
- B. Maximum Support Spacing and Minimum Hanger Rod Size for Raceway: Space supports for EMT, IMC, and RMC as required by NFPA 70. Minimum rod size shall be 1/4 inch in diameter.
- C. Multiple Raceways or Cables: Install trapeze-type supports fabricated with steel slotted or other support system, sized so capacity can be increased by at least 25 percent in future without exceeding specified design load limits.
 - 1. Secure raceways and cables to these supports with two-bolt conduit clamps.
- D. Spring-steel clamps designed for supporting single conduits without bolts may be used for 1-1/2-inch and smaller raceways serving branch circuits and communication systems above suspended ceilings and for fastening raceways to trapeze supports.

3.02 SUPPORT INSTALLATION

- A. Comply with NECA 1 and NECA 101 for installation requirements except as specified in this Article.
- B. Raceway Support Methods: In addition to methods described in NECA 1, EMT, IMC, and RMC may be supported by openings through structure members, as permitted in NFPA 70.
- C. Strength of Support Assemblies: Where not indicated, select sizes of components so strength will be adequate to carry present and future static loads within specified loading limits. Minimum static design load used for strength determination shall be weight of supported components plus 200 lb.
- D. Mounting and Anchorage of Surface-Mounted Equipment and Components: Anchor and fasten electrical items and their supports to building structural elements by the following methods unless otherwise indicated by code:
 - 1. To Wood: Fasten with lag screws or through bolts.
 - 2. To New Concrete: Bolt to concrete inserts.
 - 3. To Masonry: Approved toggle-type bolts on hollow masonry units and expansion anchor fasteners on solid masonry units.
 - 4. To Existing Concrete: Expansion anchor fasteners.
 - 5. Instead of expansion anchors, powder-actuated driven threaded studs provided with lock washers and nuts may be used in existing standard-weight concrete 4 inches thick or greater. Do not use for anchorage to lightweight-aggregate concrete or for slabs less than 4 inches thick.
 - 6. To Steel: Welded threaded studs complying with AWS D1.1/D1.1M, with lock washers and nuts.
 - 7. To Light Steel: Sheet metal screws.
 - 8. Items Mounted on Hollow Walls and Nonstructural Building Surfaces: Mount cabinets, panelboards, disconnect switches, control enclosures, pull and junction boxes, transformers, and other devices on slotted-channel racks attached to substrate by means that meet seismic-restraint strength and anchorage requirements.

- E. Drill holes for expansion anchors in concrete at locations and to depths that avoid reinforcing bars.

3.03 INSTALLATION OF FABRICATED METAL SUPPORTS

- A. Comply with installation requirements in Division 05 Section "Metal Fabrications" for site-fabricated metal supports.
- B. Cut, fit, and place miscellaneous metal supports accurately in location, alignment, and elevation to support and anchor electrical materials and equipment.
- C. Field Welding: Comply with AWS D1.1/D1.1M.

3.04 CONCRETE BASES

- A. Construct concrete bases of dimensions indicated but not less than 4 inches larger in both directions than supported unit, and so anchors will be a minimum of 10 bolt diameters from edge of the base.
- B. Use 3000-psi, 28-day compressive-strength concrete. Concrete materials, reinforcement, and placement requirements are specified in Division 03 Section "Cast-in-Place Concrete."
- C. Anchor equipment to concrete base.
 - 1. Place and secure anchorage devices. Use supported equipment manufacturer's setting drawings, templates, diagrams, instructions, and directions furnished with items to be embedded.
 - 2. Install anchor bolts to elevations required for proper attachment to supported equipment.
 - 3. Install anchor bolts according to anchor-bolt manufacturer's written instructions.

3.05 PAINTING

- A. Touchup: Clean field welds and abraded areas of shop paint. Paint exposed areas immediately after erecting hangers and supports. Use same materials as used for shop painting. Comply with SSPC-PA 1 requirements for touching up field-painted surfaces.
 - 1. Apply paint by brush or spray to provide minimum dry film thickness of 2.0 mils.
- B. Galvanized Surfaces: Clean welds, bolted connections, and abraded areas and apply galvanizing-repair paint to comply with ASTM A 780.

END OF SECTION

SECTION 260533 - RACEWAY AND BOXES FOR ELECTRICAL SYSTEMS

PART 1 - GENERAL

1.01 RELATED DOCUMENTS

- A. Drawings and general provisions of the Contract, including General and Supplementary Conditions and Division 01 Specification Sections, apply to this Section.
- B. Requirements of Division 16 "BASIC ELECTRICAL REQUIREMENTS" apply to this Section

1.02 SUMMARY

- A. This Section includes raceways, fittings, boxes, enclosures, and cabinets for electrical wiring.
- B. Related Sections include the following:
 - 1. Division 26 Section "Underground Ducts and Raceways for Electrical Systems" for exterior ductbanks, manholes, and underground utility construction.

1.03 DEFINITIONS

- A. EMT: Electrical metallic tubing.
- B. ENT: Electrical nonmetallic tubing.
- C. EPDM: Ethylene-propylene-dieneterpolymer rubber.
- D. FMC: Flexible metal conduit.
- E. IMC: Intermediate metal conduit.
- F. LFMC: Liquidtight flexible metal conduit.
- G. LFNC: Liquidtight flexible nonmetallic conduit.
- H. NBR: Acrylonitrile-butadiene rubber.
- I. RNC: Rigid nonmetallic conduit.

1.04 SUBMITTALS

- A. Product Data: For surface raceways, wireways and fittings, floor boxes, hinged-cover enclosures, and cabinets.
- B. Manufacturer's instructions: indicate application conditions, limitations and maximum conductor fill.
- C. Shop Drawings: For the following raceway components. Include plans, elevations, sections, details, and attachments to other work.
 - 1. Custom enclosures and cabinets.
 - 2. For handholes and boxes for underground wiring, including the following:
 - a. Duct entry provisions, including locations and duct sizes.
 - b. Frame and cover design.
 - c. Grounding details.
 - d. Dimensioned locations of cable rack inserts, and pulling-in and lifting irons.
 - e. Joint details.

- D. Coordination Drawings: Conduit routing plans, drawn to scale, on which the following items are shown and coordinated with each other, based on input from installers of the items involved:
 - 1. Structural members in the paths of conduit groups with common supports.
 - 2. HVAC and plumbing items and architectural features in the paths of conduit groups with common supports.
- E. Qualification Data: For professional engineer and testing agency.
- F. Source quality-control test reports.

1.05 QUALITY ASSURANCE

- A. Electrical Components, Devices, and Accessories: Listed and labeled as defined in NFPA 70, Article 100, by a testing agency acceptable to authorities having jurisdiction, and marked for intended use.
- B. Comply with NFPA 70, UL 5 surface metal electric raceways and fittings Guide RJPR, UL 870 wire way, auxiliary gutters and associated fittings.

PART 2 - PRODUCTS

2.01 METAL CONDUIT AND TUBING

- A. Available Manufacturers: Subject to compliance with requirements, manufacturers offering products that may be incorporated into the Work include, but are not limited to, the following:
Manufacturers: Subject to compliance with requirements, provide products by one of the following: **Acceptable Manufacturers:, Triangle, Republic, Carlen, , Centex, Western Tube Appleton, Crouse Hinds, Steel City, OOZY. Gender, Race**
 - 1. AFC Cable Systems, Inc.
 - 2. Alflex Inc.
 - 3. Allied Tube & Conduit; a Tyco International Ltd. Co.
 - 4. Anamet Electrical, Inc.; Anaconda Metal Hose.
 - 5. Electri-Flex Co.
 - 6. Manhattan/CDT/Cole-Flex.
 - 7. Maverick Tube Corporation.
 - 8. O-Z Gedney; a unit of General Signal.
 - 9. Wheatland Tube Company.
- B. Rigid Steel Conduit: ANSI C80.1.
- C. Aluminum Rigid Conduit: ANSI C80.5.
- D. IMC: ANSI C80.6.
- E. PVC-Coated Steel Conduit: PVC-coated rigid steel conduit.
 - 1. Comply with NEMA RN 1.
 - 2. Coating Thickness: 0.040 inch, minimum.
- F. EMT: ANSI C80.3.
- G. FMC: Zinc-coated steel or aluminum
- H. LFMC: Flexible steel conduit with PVC jacket.

- I. Fittings for Conduit (Including all Types and Flexible and Liquidtight), EMT, and Cable: NEMA FB 1; listed for type and size raceway with which used, and for application and environment in which installed.
 - 1. Conduit Fittings for Hazardous (Classified) Locations: Comply with UL 886.
 - 2. Fittings for EMT: compression type.
 - 3. Coating for Fittings for PVC-Coated Conduit: Minimum thickness, 0.040 inch, with overlapping sleeves protecting threaded joints.
- J. Joint Compound for Rigid Steel Conduit or IMC: Listed for use in cable connector assemblies, and compounded for use to lubricate and protect threaded raceway joints from corrosion and enhance their conductivity.

2.02 NONMETALLIC CONDUIT AND TUBING

- A. Available Manufacturers: Subject to compliance with requirements, manufacturers offering products that may be incorporated into the Work include, but are not limited to, the following:
- B. Manufacturers: Subject to compliance with requirements, provide products by one of the following:
 - 1. AFC Cable Systems, Inc.
 - 2. Anamet Electrical, Inc.; Anaconda Metal Hose.
 - 3. Arco Corporation.
 - 4. CANTEX Inc.
 - 5. CertainTeed Corp.; Pipe & Plastics Group.
 - 6. Condux International, Inc.
 - 7. ElecSYS, Inc.
 - 8. Electri-Flex Co.
 - 9. Lamson & Sessions; Carlon Electrical Products.
 - 10. Manhattan/CDT/Cole-Flex.
 - 11. RACO; a Hubbell Company.
 - 12. Thomas & Betts Corporation.
- C. ENT: NEMA TC 13.
- D. RNC: NEMA TC 2, Type EPC-40-PVC, unless otherwise indicated.
- E. LFNC: UL 1660.
- F. Fittings for ENT and RNC: NEMA TC 3; match to conduit or tubing type and material.
- G. Fittings for LFNC: UL 514B.

2.03 OPTICAL FIBER/COMMUNICATIONS CABLE RACEWAY AND FITTINGS

- A. Available Manufacturers: Subject to compliance with requirements, manufacturers offering products that may be incorporated into the Work include, but are not limited to, the following:
- B. Manufacturers: Subject to compliance with requirements, provide products by one of the following:
 - 1. Arco Corporation.
 - 2. Endot Industries Inc.
 - 3. IPEX Inc.
 - 4. Lamson & Sessions; Carlon Electrical Products.

- C. Description: Comply with UL 2024; flexible type, approved for general-use installation.

2.04 METAL WIREWAYS

- A. Available Manufacturers: Subject to compliance with requirements, manufacturers offering products that may be incorporated into the Work include, but are not limited to, the following:
- B. Manufacturers: Subject to compliance with requirements, provide products by one of the following:
 - 1. Cooper B-Line, Inc.
 - 2. Hoffman.
 - 3. Square D; Schneider Electric.
 - 4. Tanco.
 - 5. General Electric.
 - 6. Westinghouse/Cutler Hammer.
- C. Description: Sheet metal sized and shaped as indicated, NEMA 250, Type 1, 12, 3R, unless otherwise indicated. Provide electrical wire ways of grades and number of channels for each type of service as indicated. Comply with U.L. 870 "Wire way, Auxiliary Gutters and Associated Fittings." And NEC 366.
- D. Fittings and Accessories: Include couplings, offsets, elbows, expansion joints, adapters, hold-down straps, end caps, and other fittings to match and mate with wireways as required for complete system.
- E. Connectors: Provide wireway connectors suitable for "lay-in" conductors, with connector covers permanently attached that removal is not necessary to utilize the lay-in feature.
- F. Wireway Covers: Lay-In Wire ways: Construct lay-in wire ways with hinged covers with components UL-listed, including lengths, connectors, and fittings. Select units to allow fastening hinged cover closed without use of parts other than standard lengths, fittings and connectors. Construct units to be capable of sealing cover in closed position with sealing wire. Provide wire ways with knockouts.
- G. Finish: Protect sheet metal parts with rust inhibiting coating and baked enamel finish. Plate finish hardware to prevent corrosion. Protect screws installed toward inside of wireway with spring nuts to prevent wire insulation damage.
- H. Rain tight Wireway: Construct rain tight lay-in wire ways with hinged covers with components UL-listed, including lengths, connectors and fittings. Design units to allow fastening hinged cover closed without use of parts other than standard lengths, fittings and connectors. Construct units to be capable of sealing cover in closed position with sealing wire. Provide wireway units with knockouts only in bottom of troughs
 - 1. Construction: 16-gauge galvanized sheet metal parts for 4" x 4" to 6" x 6" sections, and 14-gauge parts for 8" x 8" and larger sections. Provide knockouts only in bottom of troughs, with suitable adapters to facilitate attaching to other NEMA 3R enclosures. Do not use gasketing that can rip or tear during installation, or would compromise rain tight capability of the trough area and damage wire insulation.
 - 2. Finish: Provide 14-gauge and 16-gauge galvanized sheet metal parts with corrosion-resistant phosphate primer and baked enamel finish. Plate hardware to prevent corrosion.

2.05 NONMETALLIC WIREWAYS

- A. Available Manufacturers: Subject to compliance with requirements, manufacturers offering products that may be incorporated into the Work include, but are not limited to, the following:

- B. Manufacturers: Subject to compliance with requirements, provide products by one of the following:
 - 1. Hoffman.
 - 2. Lamson & Sessions; Carlon Electrical Products.
- C. Description: Fiberglass polyester, extruded and fabricated to size and shape indicated, with no holes or knockouts. Cover is gasketed with oil-resistant gasket material and fastened with captive screws treated for corrosion resistance. Connections are flanged, with stainless-steel screws and oil-resistant gaskets.
- D. Description: PVC plastic, extruded and fabricated to size and shape indicated, with snap-on cover and mechanically coupled connections with plastic fasteners.
- E. Fittings and Accessories: Include couplings, offsets, elbows, expansion joints, adapters, hold-down straps, end caps, and other fittings to match and mate with wireways as required for complete system.

2.06 SURFACE RACEWAYS

- A. Surface Metal Raceways: Galvanized steel with snap-on covers. Manufacturer's standard enamel finish in color selected by Architect.
 - 1. Available Manufacturers: Subject to compliance with requirements, manufacturers offering products that may be incorporated into the Work include, but are not limited to, the following:
 - 2. Manufacturers: Subject to compliance with requirements, provide products by one of the following:
 - a. Thomas & Betts Corporation.
 - b. Walker Systems, Inc.; Wiremold Company (The).
 - c. Wiremold Company (The); Electrical Sales Division.
 - 3. Multi outlet assemblies shall be used to provide power and/or low potential services as shown on the building plans.
 - 4. The Electrical Contractor shall provide and install all surface metal raceways and appropriate fittings to provide safe and complete installation. The surface metal raceway and fittings shall be the two-piece with receptacles and data outlets (if any) as indicated.
 - 5. When power and data are indicated, the raceway shall afford the capability of being divided into two equal but separate wiring compartments to facilitate installation of power and low potential wiring. "Separate compartments are to be identified by sharply contrasting colors of the interior finish of the divider."
 - 6. A full line of fittings for the surface metal raceway shall be available. This shall include but not limited to elbows (90, internal and external), couplings for joining raceway sections, wire clips for holding conductors or cables in place, blank end fittings for closing open ends of the raceway, transition connectors to other surface metal communications (if any). All openings shall be grommet. Voice/Data connections (if any) shall be provided with interchangeable LAN adapters. When power and data are indicated, device brackets to install single or two gang devices within the raceway and combination receptacle and telephone outlet covers shall be available.
 - 7. The surface metal raceway and fittings shall meet all requirements of the NEC Article 376 and 380, and shall be listed by Underwriter's Laboratories, Inc. in full compliance with their standard for surface metal raceways and fittings (UL-5).
 - 8. Multi outlet assemblies shall be Wiremold 2000 series with 5-15R simplex receptacles 18" on center.

9. Verify finish color with architect.
- B. Surface Nonmetallic Raceways: Two-piece construction, manufactured of rigid PVC with texture and color selected by Architect from manufacturer's standard colors.
 1. Available Manufacturers: Subject to compliance with requirements, manufacturers offering products that may be incorporated into the Work include, but are not limited to, the following:
 2. Manufacturers: Subject to compliance with requirements, provide products by one of the following:
 - a. Butler Manufacturing Company; Walker Division.
 - b. Enduro Systems, Inc.; Composite Products Division.
 - c. Hubbell Incorporated; Wiring Device-Kellems Division.
 - d. Lamson & Sessions; Carlon Electrical Products.
 - e. Panduit Corp.
 - f. Walker Systems, Inc.; Wiremold Company (The).
 - g. Wiremold Company (The); Electrical Sales Division.
 3. Multi outlet assemblies shall be used to provide power and/or low potential services as shown on the building plans.
 4. The Electrical Contractor shall provide and install all surface metal raceways and appropriate fittings to provide safe and complete installation. The surface metal raceway and fittings shall be the two-piece with receptacles and data outlets (if any) as indicated.
 5. When power and data are indicated, the raceway shall afford the capability of being divided into two equal but separate wiring compartments to facilitate installation of power and low potential wiring. "Separate compartments are to be identified by sharply contrasting colors of the interior finish of the divider."
 6. A full line of fittings for the surface metal raceway shall be available. This shall include but not limited to elbows (90, internal and external), couplings for joining raceway sections, wire clips for holding conductors or cables in place, blank end fittings for closing open ends of the raceway, transition connectors to other surface metal communications (if any). All openings shall be grommet. Voice/Data connections (if any) shall be provided with interchangeable LAN adapters. When power and data are indicated, device brackets to install single or two gang devices within the raceway and combination receptacle and telephone outlet covers shall be available.
 7. The surface nonmetal raceway and fittings shall meet all requirements of the NEC Article 376 and 380, and shall be listed by Underwriter's Laboratories, Inc. in full compliance with their standard for surface metal raceways and fittings (UL-5).
 8. Multi outlet assemblies shall be Wiremold NM2000 series with 5-15R simplex receptacles 18" on center.
 9. Verify finish color with architect.

2.07 BOXES, ENCLOSURES, AND CABINETS

- A. Available Manufacturers: Subject to compliance with requirements, manufacturers offering products that may be incorporated into the Work include, but are not limited to, the following:
- B. Manufacturers: Subject to compliance with requirements, provide products by one of the following:
 1. Cooper Crouse-Hinds; Div. of Cooper Industries, Inc.
 2. EGS/Appleton Electric.

3. Erickson Electrical Equipment Company.
 4. Hoffman.
 5. Hubbell Incorporated; Killark Electric Manufacturing Co. Division.
 6. O-Z/Gedney; a unit of General Signal.
 7. RACO; a Hubbell Company.
 8. Robroy Industries, Inc.; Enclosure Division.
 9. Scott Fetzer Co.; Adalet Division.
 10. Spring City Electrical Manufacturing Company.
 11. Thomas & Betts Corporation.
 12. Walker Systems, Inc.; Wiremold Company (The).
 13. Woodhead, Daniel Company; Woodhead Industries, Inc. Subsidiary.
- C. Sheet Metal Outlet and Device Boxes: NEMA OS 1.
- D. Cast-Metal Outlet and Device Boxes: NEMA FB 1, aluminum, Type FD, with gasketed cover.
- E. Nonmetallic Outlet and Device Boxes: NEMA OS 2.
- F. Metal Floor Boxes: Cast or sheet metal rectangular.
- G. Nonmetallic Floor Boxes: Nonadjustable, round.
- H. Small Sheet Metal Pull and Junction Boxes: NEMA OS 1.
- I. Cast-Metal Access, Pull, and Junction Boxes: NEMA FB 1, galvanized, cast iron with gasketed cover.
- J. Hinged-Cover Enclosures: NEMA 250, Type 1, with continuous-hinge cover with flush latch, unless otherwise indicated.
1. Metal Enclosures: Steel, finished inside and out with manufacturer's standard enamel.
 2. Nonmetallic Enclosures: Plastic.
- K. Cabinets:
1. NEMA 250, Type 1, galvanized-steel box with removable interior panel and removable front, finished inside and out with manufacturer's standard enamel.
 2. Hinged door in front cover with flush latch and concealed hinge.
 3. Key latch to match panelboards.
 4. Metal barriers to separate wiring of different systems and voltage.
 5. Accessory feet where required for freestanding equipment.

2.08 HANDHOLES AND BOXES FOR EXTERIOR UNDERGROUND WIRING

- A. Description: Comply with SCTE 77.
1. Color of Frame and Cover: Green.
 2. Configuration: Units shall be designed for flush burial and have closed bottom, unless otherwise indicated.
 3. Cover: Weatherproof, secured by tamper-resistant locking devices and having structural load rating consistent with enclosure.
 4. Cover Finish: Nonskid finish shall have a minimum coefficient of friction of 0.50.
 5. Cover Legend: Molded lettering, "ELECTRIC." as indicated for each service.
 6. Conduit Entrance Provisions: Conduit-terminating fittings shall mate with entering ducts for secure, fixed installation in enclosure wall.

7. Handholes 12 inches wide by 24 inches long and larger shall have inserts for cable racks and pulling-in irons installed before concrete is poured.
- B. Polymer-Concrete Handholes and Boxes with Polymer-Concrete Cover: Molded of sand and aggregate, bound together with polymer resin, and reinforced with steel or fiberglass or a combination of the two.
 1. Available Manufacturers: Subject to compliance with requirements, manufacturers offering products that may be incorporated into the Work include, but are not limited to, the following:
 - a. Armorcast Products Company.
 - b. Carson Industries LLC.
 - c. CDR Systems Corporation.
 - d. NewBasis.
- C. Fiberglass Handholes and Boxes with Polymer-Concrete Frame and Cover: Sheet-molded, fiberglass-reinforced, polyester-resin enclosure joined to polymer-concrete top ring or frame.
 1. Available Manufacturers: Subject to compliance with requirements, manufacturers offering products that may be incorporated into the Work include, but are not limited to, the following:
 - a. Armorcast Products Company.
 - b. Carson Industries LLC.
 - c. Christy Concrete Products.
 - d. Synertech Moulded Products, Inc.; a division of Oldcastle Precast.

2.09 SLEEVES FOR RACEWAYS

- A. Steel Pipe Sleeves: ASTM A 53/A 53M, Type E, Grade B, Schedule 40, galvanized steel, plain ends.
- B. Cast-Iron Pipe Sleeves: Cast or fabricated "wall pipe," equivalent to ductile-iron pressure pipe, with plain ends and integral water stop, unless otherwise indicated.
- C. Sleeves for Rectangular Openings: Galvanized sheet steel with minimum 0.052- or 0.138-inch thickness as indicated and of length to suit application.
- D. Coordinate sleeve selection and application with selection and application of firestopping specified in Division 07 Section "Penetration Firestopping."

2.10 SLEEVE SEALS

- A. Available Manufacturers: Subject to compliance with requirements, manufacturers offering products that may be incorporated into the Work include, but are not limited to, the following:
 1. Advance Products & Systems, Inc.
 2. Calpico, Inc.
 3. Metraflex Co.
 4. Pipeline Seal and Insulator, Inc.
- B. Description: Modular sealing device, designed for field assembly, to fill annular space between sleeve and cable.
 1. Sealing Elements: EPDM interlocking links shaped to fit surface of cable or conduit. Include type and number required for material and size of raceway or cable.
 2. Pressure Plates: Plastic. Include two for each sealing element.

3. Connecting Bolts and Nuts: Carbon steel with corrosion-resistant coating of length required to secure pressure plates to sealing elements. Include one for each sealing element.

2.11 SOURCE QUALITY CONTROL FOR UNDERGROUND ENCLOSURES

- A. Handhole and Pull-Box Prototype Test: Test prototypes of handholes and boxes for compliance with SCTE 77. Strength tests shall be for specified tier ratings of products supplied.
 1. Tests of materials shall be performed by a independent testing agency.
 2. Strength tests of complete boxes and covers shall be by either an independent testing agency or manufacturer. A qualified registered professional engineer shall certify tests by manufacturer.
 3. Testing machine pressure gages shall have current calibration certification complying with ISO 9000 and ISO 10012, and traceable to NIST standards.

PART 3 - EXECUTION

3.01 RACEWAY APPLICATION

- A. Outdoors: Apply raceway products as specified below, unless otherwise indicated:
 1. Exposed Conduit: Rigid steel conduit IMC.
 2. Concealed Conduit, Aboveground: Rigid steel conduit IMC EMT.
 3. Underground Conduit: RNC, Type EPC-40-PVC, direct buried.
 4. Connection to Vibrating Equipment (Including Transformers and Hydraulic, Pneumatic, Electric Solenoid, or Motor-Driven Equipment): LFMC.
 5. Boxes and Enclosures, Aboveground: NEMA 250, Type 3R.
 6. Application of Handholes and Boxes for Underground Wiring:
 - a. Handholes and Pull Boxes in Driveway, Parking Lot, and Off-Roadway Locations, Subject to Occasional, Non-deliberate Loading by Heavy Vehicles: Polymer concrete, SCTE 77, Tier 15 structural load rating.
 - b. Handholes and Pull Boxes in Sidewalk and Similar Applications with a Safety Factor for Non-deliberate Loading by Vehicles: Polymer-concrete units, SCTE 77, Tier 8 structural load rating.
 - c. Handholes and Pull Boxes Subject to Light-Duty Pedestrian Traffic Only: Fiberglass-reinforced polyester resin structurally tested according to SCTE 77 with 3000-lbf vertical loading.
- B. Comply with the following indoor applications, unless otherwise indicated:
 1. Exposed, Not Subject to Physical Damage: EMT.
 2. Exposed, Not Subject to Severe Physical Damage: EMT.
 3. Exposed and Subject to Severe Physical Damage: Rigid steel conduit or IMC. Includes raceways in the following locations:
 - a. Loading dock.
 - b. Corridors used for traffic of mechanized carts, forklifts, and pallet-handling units.
 - c. Mechanical rooms.
 4. Concealed in Ceilings and Interior Walls and Partitions: EMT.

5. Connection to Vibrating Equipment (Including Transformers and Hydraulic, Pneumatic, Electric Solenoid, or Motor-Driven Equipment): FMC, except use LFMC in damp or wet locations.
 6. Damp or Wet Locations: Rigid steel conduit or IMC.
 7. Raceways for Optical Fiber or Communications Cable in Spaces Used for Environmental Air: EMT.
 8. Raceways for Optical Fiber or Communications Cable Risers in Vertical Shafts: EMT.
 9. Raceways for Concealed General Purpose Distribution of Optical Fiber or Communications Cable: EMT.
 10. Boxes and Enclosures: NEMA 250, Type 1, except use NEMA 250, Type 4, stainless steel in damp or wet locations.
- C. Minimum Raceway Size: 3/4-inch trade size.
- D. Raceway Fittings: Compatible with raceways and suitable for use and location.
1. Rigid and Intermediate Steel Conduit: Use threaded rigid steel conduit fittings, unless otherwise indicated.
 2. PVC Externally Coated, Rigid Steel Conduits: Use only fittings listed for use with that material. Patch and seal all joints, nicks, and scrapes in PVC coating after installing conduits and fittings. Use sealant recommended by fitting manufacturer.
- E. Do not install aluminum conduits in contact with concrete.

3.02 INSTALLATION

- A. Install products in accordance with manufacturer's instructions, NEC 366, NEC 380, and NEC 376. Comply with NECA 1 for installation requirements applicable to products specified in Part 2 except where requirements on Drawings or in this Article are stricter.
- B. Use flat-head screws, clips, and straps to fasten raceway base to surfaces. Mount plumb and level.
- C. Use suitable insulating bushings and inserts at connections to outlets and corner fittings.
- D. Wireway and Auxiliary Gutter Supports: Provide steel channel as specified in Section 260529.
- E. Close ends of wireway and unused conduit openings.
- F. Ground and bond raceway and wireway under provisions of Section 260526.
- G. Keep raceways at least 6 inches away from parallel runs of flues and steam or hot-water pipes. Install horizontal raceway runs above water and steam piping.
- H. Complete raceway installation before starting conductor installation.
- I. Support raceways as specified in Division 26 Section "Hangers and Supports for Electrical Systems."
- J. Arrange stub-ups so curved portions of bends are not visible above the finished slab.
- K. Install no more than the equivalent of three 90-degree bends in any conduit run except for communications conduits, for which fewer bends are allowed.
- L. Conceal conduit and EMT within finished walls, ceilings, and floors, unless otherwise indicated.
- M. Raceways Embedded in Slabs:
 1. Run conduit larger than 1-inch trade size, parallel or at right angles to main reinforcement. Where at right angles to reinforcement, place conduit close to slab support.

2. Arrange raceways to cross building expansion joints at right angles with expansion fittings.
 3. Change from ENT to RNC, Type EPC-40-PVC, rigid steel conduit, or IMC before rising above the floor.
- N. Threaded Conduit Joints, Exposed to Wet, Damp, Corrosive, or Outdoor Conditions: Apply listed compound to threads of raceway and fittings before making up joints. Follow compound manufacturer's written instructions.
- O. Raceway Terminations at Locations Subject to Moisture or Vibration: Use insulating bushings to protect conductors, including conductors smaller than No. 4 AWG.
- P. Install pull wires in empty raceways. Use polypropylene or monofilament plastic line with not less than 200-lb tensile strength. Leave at least 12 inches of slack at each end of pull wire.
- Q. Raceways for Optical Fiber and Communications Cable: Install raceways, metallic and nonmetallic, rigid and flexible, as follows:
1. 3/4-Inch Trade Size and Smaller: Install raceways in maximum lengths of 50 feet.
 2. 1-Inch Trade Size and Larger: Install raceways in maximum lengths of 75 feet.
 3. Install with a maximum of two 90-degree bends or equivalent for each length of raceway unless Drawings show stricter requirements. Separate lengths with pull or junction boxes or terminations at distribution frames or cabinets where necessary to comply with these requirements.
- R. Install raceway sealing fittings at suitable, approved, and accessible locations and fill them with listed sealing compound. For concealed raceways, install each fitting in a flush steel box with a blank cover plate having a finish similar to that of adjacent plates or surfaces. Install raceway sealing fittings at the following points:
1. Where conduits pass from warm to cold locations, such as boundaries of refrigerated spaces.
 2. Where otherwise required by NFPA 70.
- S. Expansion-Joint Fittings for RNC: Install in each run of aboveground conduit that is located where environmental temperature change may exceed 30 deg F, and that has straight-run length that exceeds 25 feet.
1. Install expansion-joint fittings for each of the following locations, and provide type and quantity of fittings that accommodate temperature change listed for location:
 - a. Outdoor Locations Not Exposed to Direct Sunlight: 125 deg F temperature change.
 - b. Outdoor Locations Exposed to Direct Sunlight: 155 deg F temperature change.
 - c. Indoor Spaces: Connected with the Outdoors without Physical Separation: 125 deg F temperature change.
 - d. Attics: 135 deg F temperature change.
 2. Install fitting(s) that provide expansion and contraction for at least 0.00041 inch per foot of length of straight run per deg F of temperature change.
 3. Install each expansion-joint fitting with position, mounting, and piston setting selected according to manufacturer's written instructions for conditions at specific location at the time of installation.
- T. Flexible Conduit Connections: Use maximum of 72 inches of flexible conduit for recessed and semi-recessed lighting fixtures, equipment subject to vibration, noise transmission, or movement; and for transformers and motors.
1. Use LFMC in damp or wet locations subject to severe physical damage.

2. Use LFMC or LFNC in damp or wet locations not subject to severe physical damage.
- U. Recessed Boxes in Masonry Walls: Saw-cut opening for box in center of cell of masonry block, and install box flush with surface of wall.
- V. Set metal floor boxes level and flush with finished floor surface.
- W. Set nonmetallic floor boxes level. Trim after installation to fit flush with finished floor surface.

3.03 INSTALLATION OF UNDERGROUND CONDUIT

- A. Direct-Buried Conduit:
 1. Excavate trench bottom to provide firm and uniform support for conduit. Prepare trench bottom as specified in Division 31 Section "Earth Moving" for pipe less than 6 inches in nominal diameter.
 2. Install backfill as specified in Division 31 Section "Earth Moving."
 3. After installing conduit, backfill and compact. Start at tie-in point, and work toward end of conduit run, leaving conduit at end of run free to move with expansion and contraction as temperature changes during this process. Firmly hand tamp backfill around conduit to provide maximum supporting strength. After placing controlled backfill to within 12 inches of finished grade, make final conduit connection at end of run and complete backfilling with normal compaction as specified in Division 31 Section "Earth Moving."
 4. Install manufactured duct elbows for stub-ups at poles and equipment and at building entrances through the floor, unless otherwise indicated. Encase elbows for stub-up ducts throughout the length of the elbow.
 5. Install manufactured rigid steel conduit elbows for stub-ups at poles and equipment and at building entrances through the floor.
 - a. Couple steel conduits to ducts with adapters designed for this purpose, and encase coupling with 3 inches of concrete.
 - b. For stub-ups at equipment mounted on outdoor concrete bases, extend steel conduit horizontally a minimum of 60 inches from edge of equipment pad or foundation. Install insulated grounding bushings on terminations at equipment.
 6. Warning Planks: Bury warning planks approximately 12 inches above direct-buried conduits, placing those 24 inches o.c. Align planks along the width and along the centerline of conduit.

3.04 INSTALLATION OF UNDERGROUND HANDHOLES AND BOXES

- A. Install handholes and boxes level and plumb and with orientation and depth coordinated with connecting conduits to minimize bends and deflections required for proper entrances.
- B. Unless otherwise indicated, support units on a level bed of crushed stone or gravel, graded from 1/2-inch sieve to No. 4 sieve and compacted to same density as adjacent undisturbed earth.
- C. Elevation: In paved areas, set so cover surface will be flush with finished grade. Set covers of other enclosures 1 inch above finished grade.
- D. Install removable hardware, including pulling eyes, cable stanchions, cable arms, and insulators, as required for installation and support of cables and conductors and as indicated. Select arm lengths to be long enough to provide spare space for future cables, but short enough to preserve adequate working clearances in the enclosure.
- E. Field-cut openings for conduits according to enclosure manufacturer's written instructions. Cut wall of enclosure with a tool designed for material to be cut. Size holes for terminating fittings to be used, and seal around penetrations after fittings are installed.

3.05 SLEEVE INSTALLATION FOR ELECTRICAL PENETRATIONS

- A. Coordinate sleeve selection and application with selection and application of firestopping specified in Division 07 Section "Penetration Firestopping."
- B. Concrete Slabs and Walls: Install sleeves for penetrations unless core-drilled holes or formed openings are used. Install sleeves during erection of slabs and walls.
- C. Use pipe sleeves unless penetration arrangement requires rectangular sleeved opening.
- D. Rectangular Sleeve Minimum Metal Thickness:
 - 1. For sleeve cross-section rectangle perimeter less than 50 inches and no side greater than 16 inches, thickness shall be 0.052 inch.
 - 2. For sleeve cross-section rectangle perimeter equal to, or greater than, 50 inches and 1 or more sides equal to, or greater than, 16 inches, thickness shall be 0.138 inch.
- E. Fire-Rated Assemblies: Install sleeves for penetrations of fire-rated floor and wall assemblies unless openings compatible with firestop system used are fabricated during construction of floor or wall.
- F. Cut sleeves to length for mounting flush with both surfaces of walls.
- G. Extend sleeves installed in floors 2 inches above finished floor level.
- H. Size pipe sleeves to provide 1/4-inch annular clear space between sleeve and raceway unless sleeve seal is to be installed.
- I. Seal space outside of sleeves with grout for penetrations of concrete and masonry and with approved joint compound for gypsum board assemblies.
- J. Interior Penetrations of Non-Fire-Rated Walls and Floors: Seal annular space between sleeve and raceway, using joint sealant appropriate for size, depth, and location of joint. Refer to Division 07 Section "Joint Sealants" for materials and installation.
- K. Fire-Rated-Assembly Penetrations: Maintain indicated fire rating of walls, partitions, ceilings, and floors at raceway penetrations. Install sleeves and seal with firestop materials. Comply with Division 07 Section "Penetration Firestopping."
- L. Roof-Penetration Sleeves: Seal penetration of individual raceways with flexible, boot-type flashing units applied in coordination with roofing work.
- M. Aboveground, Exterior-Wall Penetrations: Seal penetrations using sleeves and mechanical sleeve seals. Select sleeve size to allow for 1-inch annular clear space between pipe and sleeve for installing mechanical sleeve seals.
- N. Underground, Exterior-Wall Penetrations: Install cast-iron "wall pipes" for sleeves. Size sleeves to allow for 1-inch annular clear space between raceway and sleeve for installing mechanical sleeve seals.

3.06 SLEEVE-SEAL INSTALLATION

- A. Install to seal underground, exterior wall penetrations.
- B. Use type and number of sealing elements recommended by manufacturer for raceway material and size. Position raceway in center of sleeve. Assemble mechanical sleeve seals and install in annular space between raceway and sleeve. Tighten bolts against pressure plates that cause sealing elements to expand and make watertight seal.

3.07 FIRESTOPPING

- A. Apply firestopping to electrical penetrations of fire-rated floor and wall assemblies to restore original fire-resistance rating of assembly. Firestopping materials and installation requirements are specified in Division 07 Section "Penetration Firestopping."

3.08 PROTECTION

- A. Provide final protection and maintain conditions that ensure coatings, finishes, and cabinets are without damage or deterioration at time of Substantial Completion.
 - 1. Repair damage to galvanized finishes with zinc-rich paint recommended by manufacturer.
 - 2. Repair damage to PVC or paint finishes with matching touchup coating recommended by manufacturer.

END OF SECTION

SECTION 260543 - UNDERGROUND DUCTS AND RACEWAYS FOR ELECTRICAL SYSTEMS

PART 1 - GENERAL

1.01 RELATED DOCUMENTS

- A. Drawings and general provisions of the Contract, including General and Supplementary Conditions and Division 01 Specification Sections, apply to this Section.

1.02 SUMMARY

- A. This Section includes the following:
 - 1. Conduit, ducts, and duct accessories for concrete-encased duct banks.
 - 2. Hand-holes and boxes.
 - 3. Manholes.

1.03 DEFINITION

- A. RNC: Rigid nonmetallic conduit.

1.04 SUBMITTALS

- A. Product Data: For the following:
 - 1. Duct-bank materials, including separators and miscellaneous components.
 - 2. Ducts and conduits and their accessories, including elbows, end bells, bends, fittings, and solvent cement.
 - 3. Accessories for manholes, hand-holes, boxes.
 - 4. Warning tape.
 - 5. Warning planks.
- B. Shop Drawings for Precast or Factory-Fabricated Underground Utility Structures: Include plans, elevations, sections, details, attachments to other work, and accessories, including the following:
 - 1. Duct entry provisions, including locations and duct sizes.
 - 2. Reinforcement details.
 - 3. Frame and cover design and manhole frame support rings.
 - 4. Ladder details.
 - 5. Grounding details.
 - 6. Dimensioned locations of cable rack inserts, pulling-in and lifting irons, and sumps.
 - 7. Joint details.
- C. Shop Drawings for Factory-Fabricated Handholes and Boxes Other Than Precast Concrete: Include dimensioned plans, sections, and elevations, and fabrication and installation details, including the following:
 - 1. Duct entry provisions, including locations and duct sizes.
 - 2. Cover design.
 - 3. Grounding details.
 - 4. Dimensioned locations of cable rack inserts, and pulling-in and lifting irons.

- D. Duct-Bank Coordination Drawings: Show duct profiles and coordination with other utilities and underground structures.
 - 1. Include plans and sections, drawn to scale, and show bends and locations of expansion fittings.
 - 2. Drawings shall be signed and sealed by a qualified professional engineer.
- E. Product Certificates: For concrete and steel used in pre-cast concrete manholes and handholes, as required by ASTM C 858.
- F. Qualification Data: For professional engineer and testing agency.
- G. Source quality-control test reports.
- H. Field quality-control test reports.

1.05 QUALITY ASSURANCE

- A. Testing Agency Qualifications: Qualified according to ASTM E 329 for testing indicated.
- B. Comply with ANSI C2.
- C. Comply with NFPA 70.

1.06 DELIVERY, STORAGE, AND HANDLING

- A. Deliver ducts to Project site with ends capped. Store nonmetallic ducts with supports to prevent bending, warping, and deforming.
- B. Store pre-cast concrete and other factory-fabricated underground utility structures at Project site as recommended by manufacturer to prevent physical damage. Arrange so identification markings are visible.
- C. Lift and support pre-cast concrete units only at designated lifting or supporting points.

1.07 PROJECT CONDITIONS

- A. Interruption of Existing Electrical Service: Do not interrupt electrical service to facilities occupied by Owner or others unless permitted under the following conditions and then only after arranging to provide temporary electrical service according to requirements indicated:
 - 1. Notify Construction Manager and Owner no fewer than two weeks in advance of proposed interruption of electrical service.
 - 2. Do not proceed with interruption of electrical service without Owner's written permission.

1.08 COORDINATION

- A. Coordinate layout and installation of ducts, manholes, hand-holes, and boxes with final arrangement of other utilities, site grading, and surface features as determined in the field.
- B. Coordinate elevations of ducts and duct-bank entrances into manholes, hand-holes, and boxes with final locations and profiles of ducts and duct banks as determined by coordination with other utilities, underground obstructions, and surface features. Revise locations and elevations from those indicated as required to suit field conditions and to ensure that duct runs drain to manholes and hand-holes, and as approved by Architect.

1.09 EXTRA MATERIALS

- A. Furnish extra materials described below that match products installed and that are packaged with protective covering for storage and identified with labels describing contents.
- B. Furnish cable-support stanchions, arms, and insulators, and associated fasteners in quantities equal to 10 percent of quantity of each item installed.

PART 2 - PRODUCTS

2.01 CONDUIT

- A. Rigid Steel Conduit: Galvanized. Comply with ANSI C80.1.
- B. RNC: NEMA TC 2, Type EPC-40-PVC and Type EPC-80-PVC, UL 651, with matching fittings by same manufacturer as the conduit, complying with NEMA TC 3 and UL 514B.

2.02 NONMETALLIC DUCTS AND DUCT ACCESSORIES

- A. Available Manufacturers: Subject to compliance with requirements, manufacturers offering products that may be incorporated into the Work include, but are not limited to, the following:
- B. Manufacturers: Subject to compliance with requirements, provide products by one of the following:
- C. Basis-of-Design Product: Subject to compliance with requirements, provide the product indicated on Drawings or a comparable product by one of the following:
 - 1. ARNCO Corp.
 - 2. Beck Manufacturing.
 - 3. Cantex, Inc.
 - 4. CertainTeed Corp.; Pipe & Plastics Group.
 - 5. Condux International, Inc.
 - 6. ElecSys, Inc.
 - 7. Electri-Flex Company.
 - 8. IPEX Inc.
 - 9. Lamson & Sessions; Carlon Electrical Products.
 - 10. Manhattan/CDT; a division of Cable Design Technologies.
 - 11. Spiraduct/AFC Cable Systems, Inc.
- D. Duct Accessories:
 - 1. Duct Separators: Factory-fabricated rigid PVC interlocking spacers, sized for type and sizes of ducts with which used, and selected to provide minimum duct spacing indicated while supporting ducts during concreting or backfilling.
 - 2. Warning Tape: Underground-line warning tape specified in Division 26 Section "Identification for Electrical Systems."
 - 3. Concrete Warning Planks: Nominal 12 by 24 by 3 inches in size, manufactured from 6000-psi concrete.
 - a. Color: Red dye added to concrete during batching.
 - b. Mark each plank with "ELECTRIC" in 2-inch- high, 3/8-inch- deep letters.

2.03 PRECAST CONCRETE HANDHOLES AND BOXES

- A. Available Manufacturers: Subject to compliance with requirements, manufacturers offering products that may be incorporated into the Work include, but are not limited to, the following:
- B. Manufacturers: Subject to compliance with requirements, provide products by one of the following:
 - 1. Carder Concrete Products.
 - 2. Christy Concrete Products.
 - 3. Elmhurst-Chicago Stone Co.

4. Oldcastle Precast Group.
 5. Riverton Concrete Products; a division of Cretex Companies, Inc.
 6. Utility Concrete Products, LLC.
 7. Utility Vault Co.
 8. Wausau Tile, Inc.
- C. Comply with ASTM C 858 for design and manufacturing processes.
- D. Description: Factory-fabricated, reinforced-concrete, monolithically poured walls and bottom unless open-bottom enclosures are indicated. Frame and cover shall form top of enclosure and shall have load rating consistent with that of hand-hole or box.
1. Frame and Cover: Weatherproof cast-iron frame, with cast-iron cover with recessed cover hook eyes and tamper-resistant, captive, cover-securing bolts.
 2. Frame and Cover: Weatherproof steel frame, with steel cover with recessed cover hook eyes and tamper-resistant, captive, cover-securing bolts.
 3. Frame and Cover: Weatherproof steel frame, with hinged steel access door assembly with tamper-resistant, captive, cover-securing bolts.
 - a. Cover Hinges: Concealed, with hold-open ratchet assembly.
 - b. Cover Handle: Recessed.
 4. Frame and Cover: Weatherproof aluminum frame with hinged aluminum access door assembly with tamper-resistant, captive, cover-securing bolts.
 - a. Cover Hinges: Concealed, with hold-open ratchet assembly.
 - b. Cover Handle: Recessed.
 5. Cover Finish: Nonskid finish shall have a minimum coefficient of friction of 0.50.
 6. Cover Legend: Molded lettering.
 7. Configuration: Units shall be designed for flush burial and have closed bottom, unless otherwise indicated.
 8. Extensions and Slabs: Designed to mate with bottom of enclosure. Same material as enclosure.
 - a. Extension shall provide increased depth of 12 inches.
 - b. Slab: Same dimensions as bottom of enclosure, and arranged to provide closure.
 9. Windows: Precast openings in walls, arranged to match dimensions and elevations of approaching ducts and duct banks plus an additional 12 inches vertically and horizontally to accommodate alignment variations.
 - a. Windows shall be located no less than 6 inches from interior surfaces of walls, floors, or frames and covers of handholes, but close enough to corners to facilitate racking of cables on walls.
 - b. Window opening shall have cast-in-place, welded wire fabric reinforcement for field cutting and bending to tie in to concrete envelopes of duct banks.
 - c. Window openings shall be framed with at least two additional No. 4 steel reinforcing bars in concrete around each opening.
 10. Duct Entrances in Handhole Walls: Cast end-bell or duct-terminating fitting in wall for each entering duct.
 - a. Type and size shall match fittings to duct or conduit to be terminated.
 - b. Fittings shall align with elevations of approaching ducts and be located near interior corners of handholes to facilitate racking of cable.

11. Handholes 12 inches wide by 24 inches long and larger shall have inserts for cable racks and pulling-in irons installed before concrete is poured.

2.04 HANDHOLES AND BOXES OTHER THAN PRECAST CONCRETE

- A. Description: Comply with SCTE 77.
 1. Color: Gray.
 2. Configuration: Units shall be designed for flush burial and have closed bottom, unless otherwise indicated.
 3. Cover: Weatherproof, secured by tamper-resistant locking devices and having structural load rating consistent with enclosure.
 4. Cover Finish: Nonskid finish shall have a minimum coefficient of friction of 0.50.
 5. Cover Legend: Molded lettering, as indicated for each service.
 6. Direct-Buried Wiring Entrance Provisions: Knockouts equipped with insulated bushings or end-bell fittings, selected to suit box material, sized for wiring indicated, and arranged for secure, fixed installation in enclosure wall.
 7. Duct Entrance Provisions: Duct-terminating fittings shall mate with entering ducts for secure, fixed installation in enclosure wall.
 8. Handholes 12 inches wide by 24 inches long and larger shall have factory-installed inserts for cable racks and pulling-in irons.
- B. Polymer Concrete Handholes and Boxes with Polymer Concrete Cover: Molded of sand and aggregate, bound together with a polymer resin, and reinforced with steel or fiberglass or a combination of the two.
 1. Available Manufacturers: Subject to compliance with requirements, manufacturers offering products that may be incorporated into the Work include, but are not limited to, the following:
 2. Manufacturers: Subject to compliance with requirements, provide products by one of the following:
 3. Basis-of-Design Product: Subject to compliance with requirements, provide the product indicated on Drawings or a comparable product by one of the following:
 - a. Armorcast Products Company.
 - b. Carson Industries LLC.
 - c. CDR Systems Corporation.
 - d. NewBasis.
- C. Fiberglass Handholes and Boxes with Polymer Concrete Frame and Cover: Sheet-molded, fiberglass-reinforced, polyester resin enclosure joined to polymer concrete top ring or frame.
 1. Available Manufacturers: Subject to compliance with requirements, manufacturers offering products that may be incorporated into the Work include, but are not limited to, the following:
 2. Manufacturers: Subject to compliance with requirements, provide products by one of the following:
 3. Basis-of-Design Product: Subject to compliance with requirements, provide the product indicated on Drawings or a comparable product by one of the following:
 - a. Armorcast Products Company.
 - b. Carson Industries LLC.
 - c. Christy Concrete Products.

- d. Synertech Moulded Products, Inc.; a division of Oldcastle Precast.
- D. Fiberglass Handholes and Boxes: Molded of fiberglass-reinforced polyester resin, with covers of polymer concrete.
 - 1. Available Manufacturers: Subject to compliance with requirements, manufacturers offering products that may be incorporated into the Work include, but are not limited to, the following:
 - 2. Manufacturers: Subject to compliance with requirements, provide products by one of the following:
 - 3. Basis-of-Design Product: Subject to compliance with requirements, provide the product indicated on Drawings or a comparable product by one of the following:
 - a. Carson Industries LLC.
 - b. Christy Concrete Products.
 - c. Nordic Fiberglass, Inc.

2.05 PRECAST MANHOLES

- A. Available Manufacturers: Subject to compliance with requirements, manufacturers offering products that may be incorporated into the Work include, but are not limited to, the following:
- B. Manufacturers: Subject to compliance with requirements, provide products by one of the following:
 - 1. Carder Concrete Products.
 - 2. Christy Concrete Products.
 - 3. Elmhurst-Chicago Stone Co.
 - 4. Oldcastle Precast Group.
 - 5. Riverton Concrete Products; a division of Cretex Companies, Inc.
 - 6. Utility Concrete Products, LLC.
 - 7. Utility Vault Co.
 - 8. Wausau Tile, Inc.
- C. Comply with ASTM C 858 and with interlocking mating sections, complete with accessories, hardware, and features.
 - 1. Windows: Precast openings in walls, arranged to match dimensions and elevations of approaching ducts and duct banks plus an additional 12 inches vertically and horizontally to accommodate alignment variations.
 - a. Windows shall be located no less than 6 inches from interior surfaces of walls, floors, or roofs of manholes, but close enough to corners to facilitate racking of cables on walls.
 - b. Window opening shall have cast-in-place, welded wire fabric reinforcement for field cutting and bending to tie in to concrete envelopes of duct banks.
 - c. Window openings shall be framed with at least two additional No. 4 steel reinforcing bars in concrete around each opening.
 - 2. Duct Entrances in Manhole Walls: Cast end-bell or duct-terminating fitting in wall for each entering duct.
 - a. Type and size shall match fittings to duct or conduit to be terminated.
 - b. Fittings shall align with elevations of approaching ducts and be located near interior corners of manholes to facilitate racking of cable.

- D. Concrete Knockout Panels: 1-1/2 to 2 inches thick, for future conduit entrance and sleeve for ground rod.
- E. Joint Sealant: Asphaltic-butyl material with adhesion, cohesion, flexibility, and durability properties necessary to withstand maximum hydrostatic pressures at the installation location with the ground-water level at grade.

2.06 CAST-IN-PLACE MANHOLES

- A. Description: Underground utility structures, constructed in place, complete with accessories, hardware, and features. Include concrete knockout panels for conduit entrance and sleeve for ground rod.
- B. Materials: Comply with ASTM C 858 and with Division 03 Section "Cast-in-Place Concrete."
- C. Structural Design Loading: As specified in Part 3 "Underground Enclosure Application" Article.

2.07 UTILITY STRUCTURE ACCESSORIES

- A. Available Manufacturers: Subject to compliance with requirements, manufacturers offering products that may be incorporated into the Work include, but are not limited to, the following:
- B. Manufacturers: Subject to compliance with requirements, provide products by one of the following:
 - 1. Bilco Company (The).
 - 2. Campbell Foundry Company.
 - 3. Carder Concrete Products.
 - 4. Christy Concrete Products.
 - 5. East Jordan Iron Works, Inc.
 - 6. Elmhurst-Chicago Stone Co.
 - 7. McKinley Iron Works, Inc.
 - 8. Neenah Foundry Company.
 - 9. NewBasis.
 - 10. Oldcastle Precast Group.
 - 11. Osburn Associates, Inc.
 - 12. Pennsylvania Insert Corporation.
 - 13. Riverton Concrete Products; a division of Cretex Companies, Inc..
 - 14. Strongwell Corporation; Lenoir City Division.
 - 15. Underground Devices, Inc.
 - 16. Utility Concrete Products, LLC.
 - 17. Utility Vault Co.
 - 18. Wausau Tile, Inc.
- C. Manhole Frames, Covers, and Chimney Components: Comply with structural design loading specified for manhole.
 - 1. Frame and Cover: Weatherproof, gray cast iron complying with ASTM A 48/A 48M, Class 30B with milled cover-to-frame bearing surfaces; diameter, 29 inches.
 - a. Cover Finish: Nonskid finish shall have a minimum coefficient of friction of 0.50.
 - b. Special Covers: Recess in face of cover designed to accept finish material in paved areas.

2. Cover Legend: Cast in. Selected to suit system.
 - a. Legend: "ELECTRIC-LV" for duct systems with power wires and cables for systems operating at 600 V and less.
 - b. Legend: "ELECTRIC-HV" for duct systems with medium-voltage cables.
 - c. Legend: "COMMUNICATION" for communications, data, and telephone duct systems.
3. Manhole Chimney Components: Precast concrete rings with dimensions matched to those of roof opening.
 - a. Mortar for Chimney Ring and Frame and Cover Joints: Comply with ASTM C 270, Type M, except for quantities less than 2.0 cu. ft. where packaged mix complying with ASTM C 387, Type M, may be used.
- D. Manhole Sump Frame and Grate: ASTM A 48/A 48M, Class 30B, gray cast iron.
- E. Pulling Eyes in Concrete Walls: Eyebolt with reinforcing-bar fastening insert, 2-inch diameter eye, and 1-by 4-inch bolt.
 1. Working Load Embedded in 6-Inch, 4000-psi Concrete: 13,000-lbf minimum tension.
- F. Pulling Eyes in Non-concrete Walls: Eyebolt with reinforced fastening, 1-1/4-inch diameter eye, rated 2500-lbf minimum tension.
- G. Pulling-In and Lifting Irons in Concrete Floors: 7/8-inch diameter, hot-dip galvanized, bent steel rod; stress relieved after forming; and fastened to reinforcing rod. Exposed triangular opening.
 1. Ultimate Yield Strength: 40,000-lbf shear and 60,000-lbf tension.
- H. Bolting Inserts for Concrete Utility Structure Cable Racks and Other Attachments: Flared, threaded inserts of noncorrosive, chemical-resistant, nonconductive thermoplastic material; 1/2-inch ID by 2-3/4 inches deep, flared to 1-1/4 inches minimum at base.
 1. Tested Ultimate Pullout Strength: 12,000 lbf minimum.
- I. Expansion Anchors for Installation after Concrete Is Cast: Zinc-plated, carbon-steel-wedge type with stainless-steel expander clip with 1/2-inch bolt, 5300-lbf rated pullout strength, and minimum 6800-lbf rated shear strength.
- J. Cable Rack Assembly: Steel, hot-dip galvanized, except insulators.
 1. Stanchions: T-section or channel; 2-1/4-inch nominal size; punched with 14 holes on 1-1/2-inch centers for cable-arm attachment.
 2. Arms: 1-1/2 inches wide, lengths ranging from 3 inches with 450-lb minimum capacity to 18 inches with 250-lb minimum capacity. Arms shall have slots along full length for cable ties and be arranged for secure mounting in horizontal position at any vertical location on stanchions.
 3. Insulators: High-glaze, wet-process porcelain arranged for mounting on cable arms.
- K. Cable Rack Assembly: Nonmetallic. Components fabricated from nonconductive, fiberglass-reinforced polymer.
 1. Stanchions: Nominal 36 inches high by 4 inches wide, with minimum of 9 holes for arm attachment.
 2. Arms: Arranged for secure, drop-in attachment in horizontal position at any location on cable stanchions, and capable of being locked in position. Arms shall be available in lengths ranging from 3 inches with 450-lb minimum capacity to 20 inches with 250-lb

minimum capacity. Top of arm shall be nominally 4 inches wide, and arm shall have slots along full length for cable ties.

- L. Duct-Sealing Compound: Non-hardening, safe for contact with human skin, not deleterious to cable insulation, and workable at temperatures as low as 35 deg F. Capable of withstanding temperature of 300 deg F without slump and adhering to clean surfaces of plastic ducts, metallic conduits, conduit coatings, concrete, masonry, lead, cable sheaths, cable jackets, insulation materials, and common metals.
- M. Fixed Manholes Ladders: Arranged for attachment to wall of manhole. Ladder and mounting brackets and braces shall be fabricated from hot-dip galvanized steel.
- N. Cover Hooks: Heavy duty, designed for lifts 60 lbf and greater. Two required.

2.08 SOURCE QUALITY CONTROL

- A. Test and inspect precast concrete utility structures according to ASTM C 1037.
- B. Non-concrete Handhole and Pull-Box Prototype Test: Test prototypes of manholes and boxes for compliance with SCTE 77. Strength tests shall be for specified tier ratings of products supplied.
 - 1. Tests of materials shall be performed by a independent testing agency.
 - 2. Strength tests of complete boxes and covers shall be by either an independent testing agency or the manufacturer. A qualified registered professional engineer shall certify tests by manufacturer.
 - 3. Testing machine pressure gages shall have current calibration certification complying with ISO 9000 and ISO 10012, and traceable to NIST standards.

PART 3 - EXECUTION

3.01 UNDERGROUND DUCT APPLICATION

- A. Ducts for Electrical Cables Over 600 V: RNC, NEMA Type EPC-40-PVC, in concrete-encased duct bank, unless otherwise indicated.
- B. Ducts for Electrical Feeders 600 V and Less: RNC, NEMA Type EPC-40 -PVC, in concrete-encased duct bank, unless otherwise indicated.
- C. Underground Ducts for Telephone, Communications, or Data Utility Service Cables: RNC, NEMA Type EPC-40-PVC, installed in concrete-encased duct bank, unless otherwise indicated.

3.02 UNDERGROUND ENCLOSURE APPLICATION

- A. Handholes and Boxes for 600 V and Less:
 - 1. Units in Roadways and Other Deliberate Traffic Paths: Precast concrete, AASHTO HB 17, H-20 structural load rating.
 - 2. Units in Driveway, Parking Lot, and Off-Roadway Locations, Subject to Occasional, Non-deliberate Loading by Heavy Vehicles: Precast concrete, AASHTO HB 17, H-20 structural load rating.
 - 3. Units in Sidewalk and Similar Applications with a Safety Factor for Non-deliberate Loading by Vehicles: Precast concrete, AASHTO HB 17, H-10 structural load rating.
 - 4. Units Subject to Light-Duty Pedestrian Traffic only: Fiberglass-reinforced polyester resin structurally tested according to SCTE 77 with 3000-lbf vertical loading.
- B. Manholes: Precast or cast-in-place concrete.

1. Units Located in Roadways and Other Deliberate Traffic Paths by Heavy or Medium Vehicles: H-20 structural load rating according to AASHTO HB 17.
2. Units Not Located in Deliberate Traffic Paths by Heavy or Medium Vehicles: H-10 load rating according to AASHTO HB 17.

3.03 EARTHWORK

- A. Excavation and Backfill: Comply with Division 31 Section "Earth Moving," but do not use heavy-duty, hydraulic-operated, compaction equipment.
- B. Restore surface features at areas disturbed by excavation and reestablish original grades, unless otherwise indicated. Replace removed sod immediately after backfilling is completed.
- C. Restore areas disturbed by trenching, storing of dirt, cable laying, and other work. Restore vegetation and include necessary top soiling, fertilizing, liming, seeding, sodding, sprigging, and mulching. Comply with Division 32 Sections "Turf and Grasses" and "Plants."
- D. Cut and patch existing pavement in the path of underground ducts and utility structures according to Division 01 Section "Cutting and Patching."

3.04 DUCT INSTALLATION

- A. Slope: Pitch ducts a minimum slope of 1:300 down toward manholes and handholes and away from buildings and equipment. Slope ducts from a high point in runs between two manholes to drain in both directions.
- B. Curves and Bends: Use 5-degree angle couplings for small changes in direction. Use manufactured long sweep bends with a minimum radius of 48 inches, both horizontally and vertically, at other locations, unless otherwise indicated and 25ft horizontally for above 600v cables.
- C. Joints: Use solvent-cemented joints in ducts and fittings and make watertight according to manufacturer's written instructions. Stagger couplings so those of adjacent ducts do not lie in same plane.
- D. Duct Entrances to Manholes and Concrete and Polymer Concrete Handholes: Use end bells, spaced approximately 10 inches o.c. for 5-inch ducts, and vary proportionately for other duct sizes.
 1. Begin change from regular spacing to end-bell spacing 10 feet from the end bell without reducing duct line slope and without forming a trap in the line.
 2. Direct-Buried Duct Banks: Install an expansion and deflection fitting in each conduit in the area of disturbed earth adjacent to manhole or handhole.
 3. Grout end bells into structure walls from both sides to provide watertight entrances.
- E. Building Wall Penetrations: Make a transition from underground duct to rigid steel conduit at least 10 feet outside the building wall without reducing duct line slope away from the building, and without forming a trap in the line. Use fittings manufactured for duct-to-conduit transition. Install conduit penetrations of building walls as specified in Division 26 Section "Common Work Results for Electrical."
- F. Sealing: Provide temporary closure at terminations of ducts that have cables pulled. Seal spare ducts at terminations. Use sealing compound and plugs to withstand at least 15-psig hydrostatic pressure.
- G. Pulling Cord: Install 100-lbf- test nylon cord in ducts, including spares.
- H. Concrete-Encased Ducts: Support ducts on duct separators.

1. Separator Installation: Space separators close enough to prevent sagging and deforming of ducts, with not less than 5 spacers per 20 feet of duct. Secure separators to earth and to ducts to prevent floating during concreting. Stagger separators approximately 6 inches between tiers. Tie entire assembly together using fabric straps; do not use tie wires or reinforcing steel that may form conductive or magnetic loops around ducts or duct groups.
 2. Concreting Sequence: Pour each run of envelope between manholes or other terminations in one continuous operation.
 - a. Start at one end and finish at the other, allowing for expansion and contraction of ducts as their temperature changes during and after the pour. Use expansion fittings installed according to manufacturer's written recommendations, or use other specific measures to prevent expansion-contraction damage.
 - b. If more than one pour is necessary, terminate each pour in a vertical plane and install 3/4-inch reinforcing rod dowels extending 18 inches into concrete on both sides of joint near corners of envelope.
 3. Pouring Concrete: Spade concrete carefully during pours to prevent voids under and between conduits and at exterior surface of envelope. Do not allow a heavy mass of concrete to fall directly onto ducts. Use a plank to direct concrete down sides of bank assembly to trench bottom. Allow concrete to flow to center of bank and rise up in middle, uniformly filling all open spaces. Do not use power-driven agitating equipment unless specifically designed for duct-bank application.
 4. Reinforcement: Reinforce concrete-encased duct banks where they cross disturbed earth and where indicated. Arrange reinforcing rods and ties without forming conductive or magnetic loops around ducts or duct groups.
 5. Forms: Use walls of trench to form side walls of duct bank where soil is self-supporting and concrete envelope can be poured without soil inclusions; otherwise, use forms.
 6. Minimum Space between Ducts: 3 inches between ducts and exterior envelope wall, 2 inches between ducts for like services, and 4 inches (between power and signal ducts).
 7. Depth: Install top of duct bank at least 24 inches below finished grade in areas not subject to deliberate traffic, and at least 30 inches below finished grade in deliberate traffic paths for vehicles, unless otherwise indicated.
 8. Stub-Ups: Use manufactured duct elbows for stub-ups at poles and equipment and at building entrances through the floor, unless otherwise indicated. Extend concrete encasement throughout the length of the elbow.
 9. Stub-Ups: Use manufactured rigid steel conduit elbows for stub-ups at poles and equipment and at building entrances through the floor.
 - a. Couple steel conduits to ducts with adapters designed for this purpose, and encase coupling with 3 inches of concrete.
 - b. Stub-Ups to Equipment: For equipment mounted on outdoor concrete bases, extend steel conduit horizontally a minimum of 60 inches from edge of base. Install insulated grounding bushings on terminations at equipment.
 10. Warning Tape: Bury warning tape approximately 12 inches above all concrete-encased ducts and duct banks. Align tape parallel to and within 3 inches of the centerline of duct bank. Provide an additional warning tape for each 12-inch increment of duct-bank width over a nominal 18 inches. Space additional tapes 12 inches apart, horizontally.
- I. Direct-Buried Duct Banks:
1. Support ducts on duct separators coordinated with duct size, duct spacing, and outdoor temperature.

2. Space separators close enough to prevent sagging and deforming of ducts, with not less than 4 spacers per 20 feet of duct. Secure separators to earth and to ducts to prevent displacement during backfill and yet permit linear duct movement due to expansion and contraction as temperature changes. Stagger spacers approximately 6 inches between tiers.
3. Excavate trench bottom to provide firm and uniform support for duct bank. Prepare trench bottoms as specified in Division 31 Section "Earth Moving" for pipes less than 6 inches in nominal diameter.
4. Install backfill as specified in Division 31 Section "Earth Moving."
5. After installing first tier of ducts, backfill and compact. Start at tie-in point and work toward end of duct run, leaving ducts at end of run free to move with expansion and contraction as temperature changes during this process. Repeat procedure after placing each tier. After placing last tier, hand-place backfill to 4 inches over ducts and hand tamp. Firmly tamp backfill around ducts to provide maximum supporting strength. Use hand tamper only. After placing controlled backfill over final tier, make final duct connections at end of run and complete backfilling with normal compaction as specified in Division 31 Section "Earth Moving."
6. Install ducts with a minimum of 3 inches between ducts for like services and 6 inches between power and signal ducts.
7. Depth: Install top of duct bank at least 36 inches below finished grade, unless otherwise indicated.
8. Set elevation of bottom of duct bank below the frost line.
9. Install manufactured duct elbows for stub-ups at poles and equipment and at building entrances through the floor, unless otherwise indicated. Encase elbows for stub-up ducts throughout the length of the elbow.
10. Install manufactured rigid steel conduit elbows for stub-ups at poles and equipment and at building entrances through the floor.
 - a. Couple steel conduits to ducts with adapters designed for this purpose, and encase coupling with 3 inches of concrete.
 - b. For equipment mounted on outdoor concrete bases, extend steel conduit horizontally a minimum of 60 inches from edge of equipment pad or foundation. Install insulated grounding bushings on terminations at equipment.
11. Warning Planks: Bury warning planks approximately 12 inches above direct-buried ducts and duct banks, placing them 24 inches o.c. Align planks along the width and along the centerline of duct bank. Provide an additional plank for each 12-inch increment of duct-bank width over a nominal 18 inches. Space additional planks 12 inches apart, horizontally.

3.05 INSTALLATION OF CONCRETE MANHOLES, HANDHOLES, AND BOXES

- A. Precast Concrete Handhole and Manhole Installation:
 1. Comply with ASTM C 891, unless otherwise indicated.
 2. Install units level and plumb and with orientation and depth coordinated with connecting ducts to minimize bends and deflections required for proper entrances.
 3. Unless otherwise indicated, support units on a level bed of crushed stone or gravel, graded from 1-inch sieve to No. 4 sieve and compacted to same density as adjacent undisturbed earth.
- B. Elevations:
 1. Manhole Roof: Install with rooftop at least 15 inches below finished grade.

2. Manhole Frame: In paved areas and traffic ways, set frames flush with finished grade. Set other manhole frames 1 inch above finished grade.
 3. Handhole Covers: In paved areas and traffic ways, set surface flush with finished grade. Set covers of other handholes 1 inch above finished grade.
 4. Where indicated, cast handhole cover frame integrally with handhole structure.
- C. Drainage: Install drains in bottom of manholes where indicated. Coordinate with drainage provisions indicated.
- D. Manhole Access: Circular opening in manhole roof; sized to match cover size.
1. Install chimney, constructed of precast concrete collars and rings to support frame and cover and to connect cover with manhole roof opening. Provide moisture-tight masonry joints and waterproof grouting for cast-iron frame to chimney.
- E. Waterproofing: Apply waterproofing to exterior surfaces of manholes after concrete has cured at least three days. Waterproofing materials and installation are specified in Division 07 Section "Elastomeric Sheet Waterproofing." After ducts have been connected and grouted, and before backfilling, waterproof joints and connections and touch up abrasions and scars. Waterproof exterior of manhole chimneys after mortar has cured at least three days.
- F. Damp proofing: Apply damp proofing to exterior surfaces of manholes after concrete has cured at least three days. Damp proofing materials and installation are specified in Division 07 Section "Bituminous Damp proofing." After ducts have been connected and grouted, and before backfilling, damp proof joints and connections and touch up abrasions and scars. Damp proof exterior of manhole chimneys after mortar has cured at least three days.
- G. Hardware: Install removable hardware, including pulling eyes, cable stanchions, and cable arms, and insulators, as required for installation and support of cables and conductors and as indicated.
- H. Field-Installed Bolting Anchors in Manholes and Concrete Handholes: Do not drill deeper than 3-7/8 inches for manholes and 2 inches for handholes, for anchor bolts installed in the field. Use a minimum of two anchors for each cable stanchion.
- I. Warning Sign: Install "Confined Space Hazard" warning sign on the inside surface of each manhole cover.

3.06 INSTALLATION OF HANDHOLES AND BOXES OTHER THAN PRECAST CONCRETE

- A. Install handholes and boxes level and plumb and with orientation and depth coordinated with connecting ducts to minimize bends and deflections required for proper entrances. Use box extension if required to match depths of ducts, and seal joint between box and extension as recommended by the manufacturer.
- B. Unless otherwise indicated, support units on a level bed of crushed stone or gravel, graded from 1/2-inch sieve to No. 4 sieve and compacted to same density as adjacent undisturbed earth.
- C. Elevation: In paved areas and traffic ways, set so cover surface will be flush with finished grade. Set covers of other handholes 1 inch above finished grade.
- D. Install removable hardware, including pulling eyes, cable stanchions, cable arms, and insulators, as required for installation and support of cables and conductors and as indicated. Select arm lengths to be long enough to provide spare space for future cables, but short enough to preserve adequate working clearances in the enclosure.
- E. Field-cut openings for ducts and conduits according to enclosure manufacturer's written instructions. Cut wall of enclosure with a tool designed for material to be cut. Size holes for terminating fittings to be used, and seal around penetrations after fittings are installed.

- F. For enclosures installed in asphalt paving and subject to occasional, non-deliberate, heavy-vehicle loading, form and pour a concrete ring encircling, and in contact with, enclosure and with top surface screeded to top of box cover frame. Bottom of ring shall rest on compacted earth.
 - 1. Concrete: 3000 psi, 28-day strength, complying with Division 03 Section "Cast-in-Place Concrete," with a troweled finish.
 - 2. Dimensions: 10 inches wide by 12 inches deep.

3.07 GROUNDING

- A. Ground underground ducts and utility structures according to Division 26 Section "Grounding and Bonding for Electrical Systems."

3.08 FIELD QUALITY CONTROL

- A. Perform the following tests and inspections and prepare test reports:
 - 1. Demonstrate capability and compliance with requirements on completion of installation of underground ducts and utility structures.
 - 2. Pull aluminum or wood test mandrel through duct to prove joint integrity and test for out-of-round duct. Provide mandrel equal to 80 percent fill of duct. If obstructions are indicated, remove obstructions and retest.
 - 3. Test manhole grounding to ensure electrical continuity of grounding and bonding connections. Measure and report ground resistance as specified in Division 26 Section "Grounding and Bonding for Electrical Systems."
- B. Correct deficiencies and retest as specified above to demonstrate compliance.

3.09 CLEANING

- A. Pull leather-washer-type duct cleaner, with graduated washer sizes, through full length of ducts. Follow with rubber duct swab for final cleaning and to assist in spreading lubricant throughout ducts.
- B. Clean internal surfaces of manholes, including sump. Remove foreign material.

END OF SECTION

SECTION 260553 - IDENTIFICATION FOR ELECTRICAL SYSTEMS

PART 1 - GENERAL

1.01 RELATED DOCUMENTS

- A. Drawings and general provisions of the Contract, including General and Supplementary Conditions and Division 01 Specification Sections, apply to this Section.

1.02 SUMMARY

- A. Section Includes:
 1. Identification for raceways.
 2. Identification of power and control cables.
 3. Identification for conductors.
 4. Underground-line warning tape.
 5. Warning labels and signs.
 6. Instruction signs.
 7. Equipment identification labels.
 8. Miscellaneous identification products.

1.03 SUBMITTALS

- A. Product Data: For each electrical identification product indicated.
- B. Samples: For each type of label and sign to illustrate size, colors, lettering style, mounting provisions, and graphic features of identification products.
- C. Identification Schedule: An index of nomenclature of electrical equipment and system components used in identification signs and labels.

1.04 QUALITY ASSURANCE

- A. Comply with ANSI A13.1.
- B. Comply with NFPA 70.
- C. Comply with 29 CFR 1910.144 and 29 CFR 1910.145.
- D. Comply with ANSI Z535.4 for safety signs and labels.
- E. Adhesive-attached labeling materials, including label stocks, laminating adhesives, and inks used by label printers, shall comply with UL 969.

1.05 COORDINATION

- A. Coordinate identification names, abbreviations, colors, and other features with requirements in other Sections requiring identification applications, Drawings, Shop Drawings, manufacturer's wiring diagrams, and the Operation and Maintenance Manual; and with those required by codes, standards, and 29 CFR 1910.145. Use consistent designations throughout Project.
- B. Coordinate installation of identifying devices with completion of covering and painting of surfaces where devices are to be applied.
- C. Coordinate installation of identifying devices with location of access panels and doors.
- D. Install identifying devices before installing acoustical ceilings and similar concealment.

PART 2 - PRODUCTS

2.01 POWER RACEWAY IDENTIFICATION MATERIALS

- A. Comply with ANSI A13.1 for minimum size of letters for legend and for minimum length of color field for each raceway size.
- B. Colors for Raceways Carrying Circuits at 600 V or Less:
 - 1. Black letters on an orange field.
 - 2. Legend: Indicate voltage and system or service type.
- C. Colors for Raceways Carrying Circuits at More Than 600 V:
 - 1. Black letters on an orange field.
 - 2. Legend: "DANGER CONCEALED HIGH VOLTAGE WIRING" with 3-inch- high letters on 20-inch centers.
- D. Self-Adhesive Vinyl Labels for Raceways Carrying Circuits at 600 V or Less: Preprinted, flexible label laminated with a clear, weather- and chemical-resistant coating and matching wraparound adhesive tape for securing ends of legend label.
- E. Snap-Around Labels for Raceways Carrying Circuits at 600 V or Less: Slit, pre-tensioned, flexible, preprinted, color-coded acrylic sleeve, with diameter sized to suit diameter of raceway or cable it identifies and to stay in place by gripping action.
- F. Snap-Around, Color-Coding Bands for Raceways Carrying Circuits at 600 V or Less: Slit, pre-tensioned, flexible, solid-colored acrylic sleeve, 2 inches long, with diameter sized to suit diameter of raceway or cable it identifies and to stay in place by gripping action.
- G. Tape and Stencil for Raceways Carrying Circuits More Than 600 V: 4-inch-wide black stripes on 10-inch centers diagonally over orange background that extends full length of raceway or duct and is 12 inches wide. Stop stripes at legends.
- H. Metal Tags: Brass or aluminum, 2 by 2 by 0.05 inch, with stamped legend, punched for use with self-locking cable tie fastener.
- I. Write-On Tags: Polyester tag, 0.010 inch thick, with corrosion-resistant grommet and cable tie for attachment to conductor or cable.
 - 1. Marker for Tags: Permanent, waterproof, black ink marker recommended by tag manufacturer.
 - 2. Marker for Tags: Machine-printed, permanent, waterproof, black ink marker recommended by printer manufacturer.

2.02 ARMORED AND METAL-CLAD CABLE IDENTIFICATION MATERIALS

- A. Comply with ANSI A13.1 for minimum size of letters for legend and for minimum length of color field for each raceway and cable size.
- B. Colors for Raceways Carrying Circuits at 600 V and Less:
 - 1. Black letters on an orange field.
 - 2. Legend: Indicate voltage and system or service type.
- C. Colors for Raceways Carrying Circuits at More Than 600 V:
 - 1. Black letters on an orange field.
 - 2. Legend: "DANGER CONCEALED HIGH VOLTAGE WIRING" with 3-inch- high letters on 20-inch centers.

- D. Self-Adhesive Vinyl Labels: Preprinted, flexible label laminated with a clear, weather- and chemical-resistant coating and matching wraparound adhesive tape for securing ends of legend label.
- E. Self-Adhesive Vinyl Tape: Colored, heavy duty, waterproof, fade resistant; 2 inches wide; compounded for outdoor use.

2.03 POWER AND CONTROL CABLE IDENTIFICATION MATERIALS

- A. Comply with ANSI A13.1 for minimum size of letters for legend and for minimum length of color field for each raceway and cable size.
- B. Self-Adhesive Vinyl Labels: Preprinted, flexible label laminated with a clear, weather- and chemical-resistant coating and matching wraparound adhesive tape for securing ends of legend label.
- C. Metal Tags: Brass or aluminum, 2 by 2 by 0.05 inch, with stamped legend, punched for use with self-locking cable tie fastener.
- D. Write-On Tags: Polyester tag, 0.010 inch thick, with corrosion-resistant grommet and cable tie for attachment to conductor or cable.
 - 1. Marker for Tags: Permanent, waterproof, black ink marker recommended by tag manufacturer.
 - 2. Marker for Tags: Machine-printed, permanent, waterproof, black ink marker recommended by printer manufacturer.
- E. Snap-Around Labels: Slit, pre-tensioned, flexible, preprinted, color-coded acrylic sleeve, with diameter sized to suit diameter of raceway or cable it identifies and to stay in place by gripping action.
- F. Snap-Around, Color-Coding Bands: Slit, pre-tensioned, flexible, solid-colored acrylic sleeve, 2 inches long, with diameter sized to suit diameter of raceway or cable it identifies and to stay in place by gripping action.

2.04 CONDUCTOR IDENTIFICATION MATERIALS

- A. Color-Coding Conductor Tape: Colored, self-adhesive vinyl tape not less than 3 mils thick by 1 to 2 inches wide.
- B. Self-Adhesive Vinyl Labels: Preprinted, flexible label laminated with a clear, weather- and chemical-resistant coating and matching wraparound adhesive tape for securing ends of legend label.
- C. Snap-Around Labels: Slit, pre-tensioned, flexible, preprinted, color-coded acrylic sleeve, with diameter sized to suit diameter of raceway or cable it identifies and to stay in place by gripping action.
- D. Snap-Around, Color-Coding Bands: Slit, pre-tensioned, flexible, solid-colored acrylic sleeve, 2 inches long, with diameter sized to suit diameter of raceway or cable it identifies and to stay in place by gripping action.
- E. Marker Tapes: Vinyl or vinyl-cloth, self-adhesive wraparound type, with circuit identification legend machine printed by thermal transfer or equivalent process.
- F. Write-On Tags: Polyester tag, 0.010 inch thick, with corrosion-resistant grommet and cable tie for attachment to conductor or cable.
 - 1. Marker for Tags: Permanent, waterproof, black ink marker recommended by tag manufacturer.

2. Marker for Tags: Machine-printed, permanent, waterproof, black ink marker recommended by printer manufacturer.

2.05 FLOOR MARKING TAPE

- A. 2-inch- wide, 5-mil pressure-sensitive vinyl tape, with black and white stripes and clear vinyl overlay.

2.06 UNDERGROUND-LINE WARNING TAPE

- A. Tape:
 1. Recommended by manufacturer for the method of installation and suitable to identify and locate underground electrical and communications utility lines.
 2. Printing on tape shall be permanent and shall not be damaged by burial operations.
 3. Tape material and ink shall be chemically inert, and not subject to degrading when exposed to acids, alkalis, and other destructive substances commonly found in soils.
- B. Color and Printing:
 1. Comply with ANSI Z535.1 through ANSI Z535.5.
 2. Inscriptions for Red-Colored Tapes: ELECTRIC LINE, HIGH VOLTAGE.
 3. Inscriptions for Orange-Colored Tapes: TELEPHONE, COMMUNICATIONS CABLE, OPTICAL FIBER CABLE.

2.07 WARNING LABELS AND SIGNS

- A. Comply with NFPA 70 and 29 CFR 1910.145.
- B. Self-Adhesive Warning Labels: Factory-printed, multicolor, pressure-sensitive adhesive labels, configured for display on front cover, door, or other access to equipment unless otherwise indicated.
- C. Baked-Enamel Warning Signs:
 1. Preprinted aluminum signs, punched or drilled for fasteners, with colors, legend, and size required for application.
 2. 1/4-inch grommets in corners for mounting.
 3. Nominal size, 7 by 10 inches.
- D. Warning label and sign shall include, but are not limited to, the following legends:
 1. Multiple Power Source Warning: "DANGER - ELECTRICAL SHOCK HAZARD - EQUIPMENT HAS MULTIPLE POWER SOURCES."
 2. Workspace Clearance Warning: "WARNING - OSHA REGULATION - AREA IN FRONT OF ELECTRICAL EQUIPMENT MUST BE KEPT CLEAR FOR 36 INCHES."

2.08 EQUIPMENT IDENTIFICATION LABELS

- A. Adhesive Film Label: Machine printed, in black, by thermal transfer or equivalent process. Minimum letter height shall be 3/8 inch.
- B. Adhesive Film Label with Clear Protective Overlay: Machine printed, in black, by thermal transfer or equivalent process. Minimum letter height shall be 3/8 inch. Overlay shall provide a weatherproof and UV-resistant seal for label.
- C. Self-Adhesive, Engraved, Laminated Acrylic or Melamine Label: Adhesive backed, with white letters on a dark-gray background. Minimum letter height shall be 3/8 inch.
- D. Engraved, Laminated Acrylic or Melamine Label: Punched or drilled for screw mounting. White letters on a dark-gray background. Minimum letter height shall be 3/8 inch.

- E. Stenciled Legend: In non-fading, waterproof, black ink or paint. Minimum letter height shall be 1 inch.

2.09 CABLE TIES

- A. General-Purpose Cable Ties: Fungus inert, self extinguishing, one piece, self locking, Type 6/6 nylon.
 - 1. Minimum Width: 3/16 inch.
 - 2. Tensile Strength at 73 deg F, According to ASTM D 638: 12,000 psi.
 - 3. Temperature Range: Minus 40 to plus 185 deg F.
 - 4. Color: Black except where used for color-coding.
- B. UV-Stabilized Cable Ties: Fungus inert, designed for continuous exposure to exterior sunlight, self extinguishing, one piece, self locking, Type 6/6 nylon.
 - 1. Minimum Width: 3/16 inch.
 - 2. Tensile Strength at 73 deg F, According to ASTM D 638: 12,000 psi.
 - 3. Temperature Range: Minus 40 to plus 185 deg F.
 - 4. Color: Black.
- C. Plenum-Rated Cable Ties: Self extinguishing, UV stabilized, one piece, self locking.
 - 1. Minimum Width: 3/16 inch.
 - 2. Tensile Strength at 73 deg F, According to ASTM D 638: 7000 psi.
 - 3. UL 94 Flame Rating: 94V-0.
 - 4. Temperature Range: Minus 50 to plus 284 deg F.
 - 5. Color: Black.

2.10 MISCELLANEOUS IDENTIFICATION PRODUCTS

- A. Paint: Comply with requirements in Division 09 painting Sections for paint materials and application requirements. Select paint system applicable for surface material and location (exterior or interior).
- B. Fasteners for Labels and Signs: Self-tapping, stainless-steel screws or stainless-steel machine screws with nuts and flat and lock washers.

PART 3 - EXECUTION

3.01 INSTALLATION

- A. Verify identity of each item before installing identification products.
- B. Location: Install identification materials and devices at locations for most convenient viewing without interference with operation and maintenance of equipment.
- C. Apply identification devices to surfaces that require finish after completing finish work.
- D. Self-Adhesive Identification Products: Clean surfaces before application, using materials and methods recommended by manufacturer of identification device.
- E. Attach signs and plastic labels that are not self-adhesive type with mechanical fasteners appropriate to the location and substrate.
- F. System Identification Color-Coding Bands for Raceways and Cables: Each color-coding band shall completely encircle cable or conduit. Place adjacent bands of two-color markings in contact, side by side. Locate bands at changes in direction, at penetrations of walls and floors,

at 50-foot maximum intervals in straight runs, and at 25-foot maximum intervals in congested areas.

- G. Aluminum Wraparound Marker Labels and Metal Tags: Secure tight to surface of conductor or cable at a location with high visibility and accessibility.
- H. Cable Ties: For attaching tags. Use general-purpose type, except as listed below:
 - 1. Outdoors: UV-stabilized nylon.
 - 2. In Spaces Handling Environmental Air: Plenum rated.
- I. Underground-Line Warning Tape: During backfilling of trenches install continuous underground-line warning tape directly above line at 6 to 8 inches (below finished grade. Use multiple tapes where width of multiple lines installed in a common trench exceeds 16 inches overall.
- J. Painted Identification: Comply with requirements in Division 09 painting Sections for surface preparation and paint application.

3.02 IDENTIFICATION SCHEDULE

- A. Concealed Raceways, Duct Banks, More Than 600 V, within Buildings: Tape and stencil 4-inch- wide black stripes on 10-inch centers over orange background that extends full length of raceway or duct and is 12 inches wide. Stencil legend "DANGER CONCEALED HIGH VOLTAGE WIRING" with 3-inch-high black letters on 20-inch centers. Stop stripes at legends. Apply to the following finished surfaces:
 - 1. Floor surface directly above conduits running beneath and within 12 inches of a floor that is in contact with earth or is framed above unexcavated space.
 - 2. Wall surfaces directly external to raceways concealed within wall.
 - 3. Accessible surfaces of concrete envelope around raceways in vertical shafts, exposed in the building, or concealed above suspended ceilings.
- B. Accessible Raceways and Metal-Clad Cables, 600 V or Less, for Service, Feeder, and Branch Circuits More Than 30 A, and 120 V to ground: Identify with self-adhesive vinyl label. Install labels at 10-foot maximum intervals.
- C. Accessible Raceways and Cables within Buildings: Identify the covers of each junction and pull box of the following systems with self-adhesive vinyl labels with the wiring system legend and system voltage. System legends shall be as follows:
 - 1. Emergency Power.
 - 2. Power.
- D. Power-Circuit Conductor Identification, 600 V or Less: For conductors in vaults, pull and junction boxes, manholes, and hand-holes, use color-coding conductor tape to identify the phase.
 - 1. Color-Coding for Phase and Voltage Level Identification, 600 V or Less: Use colors listed below for ungrounded service, feeder, and branch-circuit conductors.
 - a. Color shall be factory applied or field applied for sizes larger than No. 8 AWG, if authorities having jurisdiction permit.
 - b. Colors for 208/120-V Circuits:
 - (1) Phase A: Black.
 - (2) Phase B: Red.
 - (3) Phase C: Blue.
 - c. Colors for 480/277-V Circuits:

- (1) Phase A: Brown.
 - (2) Phase B: Orange.
 - (3) Phase C: Yellow.
- d. Field-Applied, Color-Coding Conductor Tape: Apply in half-lapped turns for a minimum distance of 6 inches from terminal points and in boxes where splices or taps are made. Apply last two turns of tape with no tension to prevent possible unwinding. Locate bands to avoid obscuring factory cable markings.
- E. Power-Circuit Conductor Identification, More than 600 V: For conductors in vaults, pull and junction boxes, manholes, and hand-holes, use nonmetallic plastic tag holder with adhesive-backed phase tags, and a separate tag with the circuit designation.
- F. Install instructional sign including the color code for grounded and ungrounded conductors using adhesive-film-type labels.
- G. Conductors to Be Extended in the Future: Attach marker tape to conductors and list source.
- H. Auxiliary Electrical Systems Conductor Identification: Identify field-installed alarm, control, and signal connections.
1. Identify conductors, cables, and terminals in enclosures and at junctions, terminals, and pull points. Identify by system and circuit designation.
 2. Use system of marker tape designations that is uniform and consistent with system used by manufacturer for factory-installed connections.
 3. Coordinate identification with Project Drawings, manufacturer's wiring diagrams, and the Operation and Maintenance Manual.
- I. Locations of Underground Lines: Identify with underground-line warning tape for power, lighting, communication, and control wiring and optical fiber cable.
1. Limit use of underground-line warning tape to direct-buried cables.
 2. Install underground-line warning tape for both direct-buried cables and cables in raceway.
- J. Workspace Indication: Install floor marking tape to show working clearances in the direction of access to live parts. Workspace shall be as required by NFPA 70 and 29 CFR 1926.403 unless otherwise indicated. Do not install at flush-mounted panelboards and similar equipment in finished spaces.
- K. Warning Labels for Indoor Cabinets, Boxes, and Enclosures for Power and Lighting: Self-adhesive warning labels.
1. Comply with 29 CFR 1910.145.
 2. Identify system voltage with black letters on an orange background.
 3. Apply to exterior of door, cover, or other access.
 4. For equipment with multiple power or control sources, apply to door or cover of equipment including, but not limited to, the following:
 - a. Power transfer switches.
 - b. Controls with external control power connections.
- L. Operating Instruction Signs: Install instruction signs to facilitate proper operation and maintenance of electrical systems and items to which they connect. Install instruction signs with approved legend where instructions are needed for system or equipment operation.
- M. Emergency Operating Instruction Signs: Install instruction signs with white legend on a red background with minimum 3/8-inch- high letters for emergency instructions at equipment used for power transfer.

- N. Equipment Identification Labels: On each unit of equipment, install unique designation label that is consistent with wiring diagrams, schedules, and the Operation and Maintenance Manual. Apply labels to disconnect switches and protection equipment, central or master units, control panels, control stations, terminal cabinets, and racks of each system. Systems include power, lighting, control, communication, signal, monitoring, and alarm systems unless equipment is provided with its own identification.
1. Labeling Instructions:
 - a. Indoor Equipment: Self-adhesive, engraved, laminated acrylic or melamine label. Unless otherwise indicated, provide a single line of text with 1/2-inch- high letters on 1-1/2-inch- high label; where two lines of text are required, use labels 2 inches high.
 - b. Outdoor Equipment: Engraved, laminated acrylic or melamine label.
 - c. Elevated Components: Increase sizes of labels and letters to those appropriate for viewing from the floor.
 - d. Unless provided with self-adhesive means of attachment, fasten labels with appropriate mechanical fasteners that do not change the NEMA or NRTL rating of the enclosure.
 2. Equipment to Be Labeled:
 - a. Panelboards: Typewritten directory of circuits in the location provided by panelboard manufacturer. Panelboard identification shall be laminated acrylic or melamine label.
 - b. Enclosures and electrical cabinets.
 - c. Access doors and panels for concealed electrical items.
 - d. Switchboards.
 - e. Transformers: Label that includes tag designation shown on Drawings for the transformer, feeder, and panelboards or equipment supplied by the secondary.
 - f. Substations.
 - g. Emergency system boxes and enclosures.
 - h. Motor-control centers.
 - i. Enclosed switches.
 - j. Enclosed circuit breakers.
 - k. Enclosed controllers.
 - l. Variable-speed controllers.
 - m. Push-button stations.
 - n. Power transfer equipment.
 - o. Contactors.
 - p. Remote-controlled switches, dimmer modules, and control devices.
 - q. Battery-inverter units.
 - r. Battery racks.
 - s. Power-generating units.
 - t. Monitoring and control equipment.

END OF SECTION

SECTION 262200 - LOW-VOLTAGE TRANSFORMERS

PART 1 - GENERAL

1.01 RELATED DOCUMENTS

- A. Drawings and general provisions of the Contract, including General and Supplementary Conditions and Division 01 Specification Sections, apply to this Section.

1.02 SUMMARY

- A. This Section includes the following types of dry-type transformers rated 600 V and less, with capacities up to 1000 kVA:
 - 1. Distribution transformers.
 - 2. Harmonics Mitigating (Canceling) Transformers.
 - a. Single output HMT:
 - (1) Delta-to-ZigZag 0-degree phase shift secondary.
 - (2) Wye-to-ZigZag 30-degree phase shift secondary.
 - b. Dual output HMT:
 - (1) ZigZag 0-degree and 30-degree phase shift secondaries.
 - (2) ZigZag 15-degree and 45-degree phase shift secondaries.

1.03 SUBMITTALS

- A. Product Data: Include rated nameplate data, capacities, weights, dimensions, minimum clearances, installed devices and features, and performance for each type and size of transformer indicated.
- B. Shop Drawings: Detail equipment assemblies and indicate dimensions, weights, loads, required clearances, method of field assembly, components, and location and size of each field connection.
- C. Qualification Data: For testing agency.
- D. Source quality-control test reports.
- E. Field quality-control test reports.
- F. Operation and Maintenance Data.

1.04 QUALITY ASSURANCE

- A. Source Limitations: Obtain each transformer type through one source from a single manufacturer.
- B. Electrical Components, Devices, and Accessories: Listed and labeled as defined in NFPA 70, Article 100, by a testing agency acceptable to authorities having jurisdiction, and marked for intended use.
- C. Comply with IEEE C57.12.91, "Test Code for Dry-Type Distribution and Power Transformers."
- D. Harmonics Canceling Transformers: NEMA ST-1, TP-1, TP-2 and IEEE-519-1992 compliance.

1.05 DELIVERY, STORAGE, AND HANDLING

- A. Temporary Heating: Apply temporary heat according to manufacturer's written instructions within the enclosure of each ventilated-type unit, throughout periods during which equipment is not energized and when transformer is not in a space that is continuously under normal control of temperature and humidity.

1.06 COORDINATION

- A. Coordinate size and location of concrete bases with actual transformer provided. Cast anchor-bolt inserts into bases. Concrete, reinforcement, and formwork requirements are specified in Division 03.
- B. Coordinate installation of wall-mounting and structure-hanging supports with actual transformer provided.

PART 2 - PRODUCTS

2.01 MANUFACTURERS

- A. Manufacturers: Subject to compliance with requirements, provide products by one of the following:
 - 1. Square D.
 - 2. Eaton/Cutler-Hammer.
 - 3. General Electric.
 - 4. Siemens

2.02 GENERAL TRANSFORMER REQUIREMENTS

- A. Description: Factory-assembled and -tested, air-cooled units for 60-Hz service.
- B. Cores: Grain-oriented, non-aging silicon steel.
- C. Coils: Continuous windings without splices except for taps.
 - 1. Internal Coil Connections: Brazed or pressure type.
 - 2. Coil Material: Copper.

2.03 DISTRIBUTION TRANSFORMERS

- A. Comply with NEMA ST 20, and list and label as complying with UL 1561.
- B. Cores: One leg per phase.
- C. Enclosure: Ventilated, NEMA 250, Type 2.
 - 1. Core and coil shall be encapsulated within resin compound, sealing out moisture and air.
- D. Taps for Transformers Smaller than 3 kVA: None.
- E. Taps for Transformers 7.5 to 24 kVA: Two 5 percent taps below rated voltage.
- F. Taps for Transformers 25 kVA and Larger: Two 2.5 percent taps above and two 2.5 percent taps below normal full capacity.
- G. Insulation Class: 220 deg C, UL-component-recognized insulation system with a maximum of 80 deg C rise above 40 deg C ambient temperature.
- H. Energy Efficiency for Transformers Rated 15 kVA and Larger:
 - 1. Complying with NEMA TP 1, Class 1 efficiency levels.
 - 2. Tested according to NEMA TP 2.

- I. K-Factor Rating: Transformers indicated to be K-factor rated shall comply with UL 1561 requirements for non-sinusoidal load current-handling capability to the degree defined by designated K-factor.
 - 1. Unit shall not overheat when carrying full-load current with harmonic distortion corresponding to designated K-factor.
 - 2. Indicate value of K-factor on transformer nameplate.
- J. Wall Brackets: Manufacturer's standard brackets.
- K. Fungus Proofing: Permanent fungicidal treatment for coil and core.
- L. Low-Sound-Level Requirements: Minimum of 3 dBA less than NEMA ST 20 standard sound levels when factory tested according to IEEE C57.12.91.
- M. Low-Sound-Level Requirements: Maximum sound levels, when factory tested, shall be in according to IEEE C57.12.91.

2.04 HARMONIC MITIGATING TRANSFORMERS (SINGLE AND DUAL OUTPUT)

- A. Single Output (Secondary):
 - 1. DZ0 – Delta Primary, Zig-Zag Secondary, 0 degree phase shift.
 - 2. YZ30 – Wye Primary (ungrounded neutral), Zig-Zag Secondary, 30 degree phase shift.
- B. Dual Output (Secondaries):
 - 1. Delta Primary, Zig-Zag Secondaries, 0 degree and 30 degree phase shift (each output).
 - 2. Delta Primary, Zig-Zag Secondaries, 15 degree and 45 degree phase shift (each output).
- C. Manufacturers:
 - 1. Powersmiths International T-1000
 - 2. Power Quality International
- D. Insulation and Varnish systems: 220 deg. C. Class, Epoxy polyester impregnation, 115 deg.. Temperature Rise in 40 deg. Ambient.
- E. All terminals. Including those for changing taps, must be readily accessible. Windings shall be continuous with terminations brazed or welded. 10KV BIL.
- F. Compatible with all types of linear and non-linear current and future loads.
- G. Impedance: Between 3.0% and 5.0% at rated KVA.
- H. Zero sequence Impedance/reactance less than 0.95% and 0.3% respectively.
- I. Zero sequence currents not coupled into primary windings.
- J. Voltage Taps: Two 2 ½% above and below nominal primary voltage.
- K. Enclosure: NEMA 1 or 3 as required.
- L. Efficiencies:

<u>KVA Rating</u>	<u>% Efficiency</u>	<u>KVA Rating</u>	<u>% Efficiency</u>
15	97.0	150	98.1
30	97.3	225	98.2
45	97.7	300	98.3
75	98.0	500	98.3
112.5	98.0	750	98.5

2.05 IDENTIFICATION DEVICES

- A. Nameplates: Engraved, laminated-plastic or metal nameplate for each transformer, mounted with corrosion-resistant screws. Nameplates and label products are specified in Division 26 Section "Identification for Electrical Systems."

2.06 SOURCE QUALITY CONTROL

- A. Test and inspect transformers according to IEEE C57.12.91.
- B. Factory Sound-Level Tests: Conduct sound-level tests on equipment for this Project.

PART 3 - EXECUTION

3.01 EXAMINATION

- A. Examine conditions for compliance with enclosure- and ambient-temperature requirements for each transformer.
- B. Verify that field measurements are as needed to maintain working clearances required by NFPA 70 and manufacturer's written instructions.
- C. Examine walls, floors, roofs, and concrete bases for suitable mounting conditions where transformers will be installed.
- D. Verify that ground connections are in place and requirements in Division 26 Section "Grounding and Bonding for Electrical Systems" have been met. Maximum ground resistance shall be 5 ohms at location of transformer.
- E. Proceed with installation only after unsatisfactory conditions have been corrected.

3.02 INSTALLATION

- A. Install wall-mounting transformers level and plumb with wall brackets fabricated by transformer manufacturer.
 - 1. Brace wall-mounting transformers as specified in Division 26 Section "Vibration and Seismic Controls for Electrical Systems."
- B. Construct concrete bases and anchor floor-mounting transformers according to manufacturer's written instructions.
- C. Install ALL floor mounted transformers as indicated on 4" housekeeping pads 3-inches larger than transformer, complying with manufacturer's written instructions, applicable requirements of NEC, NESC, NEMA, ANSI and IEEE standards, and in accordance with recognized industry practices to ensure that products fulfill requirements. Provide NEC working clearance in front of transformers assuming they will require examination while energized.
- D. Coordinate transformer installation work with electrical raceway and wire/cable work, as necessary for proper interface.
- E. Install floor mounted units with bolts to equipment pad with neoprene/cork vibration mounts between transformer and pad. Comply with manufacturer's indicated installation method, if any.
- F. Connect transformer units to electrical wiring system with flexible metal conduit or liquid tight flexible metal conduit. Comply with the requirements of other Division 16 sections.
- G. Tighten electrical connectors and terminals, including screws and bolts, in accordance with equipment manufacturer's published torque tightening values for equipment connectors. Where

manufacturer's torque requirements are not indicated, tighten connectors and terminals to comply with tightening torques specified in UL STD 486A.

H. Back off shipping bolts on internal vibration isolators.

3.03 CONNECTIONS

A. Ground equipment according to Division 26 Section "Grounding and Bonding for Electrical Systems."

B. Connect wiring according to Division 26 Section "Low-Voltage Electrical Power Conductors and Cables."

3.04 FIELD QUALITY CONTROL

A. Manufacturer's Field Service: Engage a factory-authorized service representative to inspect, test, and adjust components, assemblies, and equipment installations, including connections. Report results in writing.

B. Perform tests and inspections and prepare test reports.

1. Manufacturer's Field Service: Engage a factory-authorized service representative to inspect components, assemblies, and equipment installations, including connections, and to assist in testing.

C. Tests and Inspections:

1. Perform each visual and mechanical inspection and electrical test stated in NETA Acceptance Testing Specification. Certify compliance with test parameters.

D. Remove and replace units that do not pass tests or inspections and retest as specified above.

E. Infrared Scanning: Two months after Substantial Completion, perform an infrared scan of transformer connections.

1. Use an infrared-scanning device designed to measure temperature or detect significant deviations from normal values. Provide documentation of device calibration.

2. Perform 2 follow-up infrared scans of transformers, one at 4 months and the other at 11 months after Substantial Completion.

3. Prepare a certified report identifying transformer checked and describing results of scanning. Include notation of deficiencies detected, remedial action taken, and scanning observations after remedial action.

F. Test Labeling: On completion of satisfactory testing of each unit, attach a dated and signed "Satisfactory Test" label to tested component.

G. Provide equipment grounding connections for power/distribution transformers, sizes per NEC. Tighten connections to comply with tightening torques specified in UL STD 486A to assure permanent and effective grounding.

H. Transformer Testing

1. Certified Test Reports in accordance with TP-1-2002 and TP-2.

2. Open Circuit transformer tests, for calculating percent zero-sequence impedances and reactance as follows:

a. With the transformer's primary terminals open-circuited, make a low impedance connection between secondary Terminals X1, X2 and X3.

- b. Connect a variable 60HZ power source between Secondary Terminals X1, X2, X3 and X0, which includes precision revenue class voltage and current measurement instrumentation.
 - c. Increase 60HZ voltage across Terminals X1, X2, X3 and Terminal X0 until $>2/3$ full-scale readings are obtained on the voltage and current meters. In no case can the current reading exceed the full load rating of the winding under test. The values may be lower since impedance and reactance are linear.
 - d. Calculate impedance in Ohms based on the measured voltage and current values.
 - e. Based on the measured voltage, as a percentage of the rated voltage of the windings, calculate percent zero-sequence impedance and reactance.
3. Closed Circuit Transformer Tests, for calculating transformer core and copper losses as follows:
- a. In accordance with e-Rated Transformer Corporation Standard Publications VAD1-2003 and VAD2-2003.
 - b. Measure Primary and Secondary voltage and current differences simultaneously, using 'revenue class' instrumentation and calculate excitation or no-load losses and impedances/load losses.
 - c. Submit such reports as part of shop drawings submittals for each size typical transformers, based on tests done within a year or less time.
 - d. Submit such reports for all the transformers for the project, prior to shipment.
4. Design, manufacturing and testing of these transformers, in compliance with most current NEMA, IEEE and Industry standards and practices.
5. Transformer Loss Calculations based on primary and secondary voltage and current differences measured simultaneously.

3.05 ADJUSTING

- A. Record transformer secondary voltage at each unit for at least 48 hours of typical occupancy period. Adjust transformer taps to provide optimum voltage conditions at secondary terminals. Optimum is defined as not exceeding nameplate voltage plus 10 percent and not being lower than nameplate voltage minus 3 percent at maximum load conditions. Submit recording and tap settings as test results.
- B. Connect buck-boost transformers to provide nameplate voltage of equipment being served, plus or minus 5 percent, at secondary terminals.
- C. Output Settings Report: Prepare a written report recording output voltage and tap settings.

3.06 CLEANING

- A. Vacuum dirt and debris; do not use compressed air to assist in cleaning.

END OF SECTION

SECTION 262416 - PANELBOARDS

PART 1 - GENERAL

1.01 RELATED DOCUMENTS

- A. Drawings and general provisions of the Contract, including General and Supplementary Conditions and Division 01 Specification Sections, apply to this Section.

1.02 SUMMARY

- A. Section Includes:
 - 1. Distribution panelboards.
 - 2. Lighting and appliance branch-circuit panelboards.

1.03 DEFINITIONS

- A. SVR: Suppressed voltage rating.
- B. TVSS: Transient voltage surge suppressor.

1.04 SUBMITTALS

- A. Product Data: For each type of panelboard, switching and over-current protective device, transient voltage suppression device, accessory, and component indicated. Include dimensions and manufacturers' technical data on features, performance, electrical characteristics, ratings, and finishes.
- B. Shop Drawings: For each panelboard and related equipment.
 - 1. Include dimensioned plans, elevations, sections, and details. Show tabulations of installed devices, equipment features, and ratings.
 - 2. Detail enclosure types and details for types other than NEMA 250, Type 1.
 - 3. Detail bus configuration, current, and voltage ratings.
 - 4. Short-circuit current rating of panelboards and over-current protective devices.
 - 5. Include evidence of NRTL listing for series rating of installed devices.
 - 6. Detail features, characteristics, ratings, and factory settings of individual over-current protective devices and auxiliary components.
 - 7. Include wiring diagrams for power, signal, and control wiring.
 - 8. Include time-current coordination curves for each type and rating of over-current protective device included in panelboards. Submit on translucent log-log graft paper; include selectable ranges for each type of over-current protective device.
- C. Qualification Data: For qualified testing agency.
- D. Field Quality-Control Reports:
 - 1. Test procedures used.
 - 2. Test results that comply with requirements.
 - 3. Results of failed tests and corrective action taken to achieve test results that comply with requirements.
- E. Panelboard Schedules: For installation in panelboards.

- F. Operation and Maintenance Data: For panelboards and components to include in emergency, operation, and maintenance manuals. In addition to items specified in Division 01 Section "Operation and Maintenance Data," include the following:
 - 1. Manufacturer's written instructions for testing and adjusting over-current protective devices.
 - 2. Time-current curves, including selectable ranges for each type of over-current protective device that allows adjustments.

1.05 QUALITY ASSURANCE

- A. Source Limitations: Obtain panelboards, over-current protective devices, components, and accessories from single source from single manufacturer.
- B. Product Selection for Restricted Space: Drawings indicate maximum dimensions for panelboards including clearances between panelboards and adjacent surfaces and other items. Comply with indicated maximum dimensions.
- C. Electrical Components, Devices, and Accessories: Listed and labeled as defined in NFPA 70, by a qualified testing agency, and marked for intended location and application.
- D. Comply with NEMA PB 1.
- E. Comply with NFPA 70.

1.06 DELIVERY, STORAGE, AND HANDLING

- A. Remove loose packing and flammable materials from inside panelboards; install temporary electric heating (250 W per panelboard) to prevent condensation.
- B. Handle and prepare panelboards for installation according to NEMA PB 1.

1.07 PROJECT CONDITIONS

- A. Environmental Limitations:
 - 1. Do not deliver or install panelboards until spaces are enclosed and weather tight, wet work in spaces is complete and dry, work above panelboards is complete, and temporary HVAC system is operating and maintaining ambient temperature and humidity conditions at occupancy levels during the remainder of the construction period.
- B. Service Conditions: NEMA PB 1, usual service conditions, as follows:
 - 1. Ambient temperatures within limits specified.
 - 2. Altitude not exceeding 6600 feet.
- C. Interruption of Existing Electric Service: Do not interrupt electric service to facilities occupied by Owner or others unless permitted under the following conditions and then only after arranging to provide temporary electric service according to requirements indicated:
 - 1. Notify Owner no fewer than two weeks days in advance of proposed interruption of electric service.
 - 2. Comply with NFPA 70E.

1.08 COORDINATION

- A. Coordinate layout and installation of panelboards and components with other construction that penetrates walls or is supported by them, including electrical and other types of equipment, raceways, piping, encumbrances to workspace clearance requirements, and adjacent surfaces. Maintain required workspace clearances and required clearances for equipment access doors and panels.

- B. Coordinate sizes and locations of concrete bases with actual equipment provided. Cast anchor-bolt inserts into bases. Concrete, reinforcement, and formwork requirements are specified in Division 03.

1.09 WARRANTY

- A. Special Warranty: Manufacturer's standard form in which manufacturer agrees to repair or replace transient voltage suppression devices that fail in materials or workmanship within specified warranty period.
 - 1. Warranty Period: Five years from date of Substantial Completion.

1.10 EXTRA MATERIALS

- A. Furnish extra materials that match products installed and that are packaged with protective covering for storage and identified with labels describing contents.
 - 1. Keys: Two spares for each type of panelboard cabinet lock.
 - 2. Circuit Breakers Including GFCI and Ground Fault Equipment Protection (GFEP) Types: Two spares for each panelboard.
 - 3. Fuses for Fused Switches: Equal to 10 percent of quantity installed for each size and type, but no fewer than three of each size and type.
 - 4. Fuses for Fused Power-Circuit Devices: Equal to 10 percent of quantity installed for each size and type, but no fewer than three of each size and type.

PART 2 - PRODUCTS

2.01 GENERAL REQUIREMENTS FOR PANELBOARDS

- A. Fabricate and test panelboards according to IEEE 344 to withstand seismic forces defined in Division 26 Section "Vibration and Seismic Controls for Electrical Systems."
- B. Enclosures: Flush- and surface-mounted cabinets.
 - 1. Rated for environmental conditions at installed location.
 - a. Indoor Dry and Clean Locations: NEMA 250, Type 1.
 - b. Outdoor Locations: NEMA 250, Type 3R.
 - c. Wash-Down Areas: NEMA 250, Type 4X stainless steel.
 - d. Other Wet or Damp Indoor Locations: NEMA 250, Type 4.
 - e. Indoor Locations Subject to Dust, Falling Dirt, and Dripping Non-corrosive Liquids: NEMA 250, Type 5.
 - 2. Front: Secured to box with concealed trim clamps. For surface-mounted fronts, match box dimensions; for flush-mounted fronts, overlap box.
 - 3. Hinged Front Cover: Entire front trim hinged to box and with standard door within hinged trim cover.
 - 4. Skirt for Surface-Mounted Panelboards: Same gage and finish as panelboard front with flanges for attachment to panelboard, wall, and ceiling or floor.
 - 5. Gutter Extension and Barrier: Same gage and finish as panelboard enclosure; integral with enclosure body. Arrange to isolate individual panel sections.
 - 6. Finishes:
 - a. Panels and Trim: Steel and galvanized steel, factory finished immediately after cleaning and pre-treating with manufacturer's standard two-coat, baked-on finish consisting of prime coat and thermosetting topcoat.

- b. Back Boxes: Same finish as panels and trim.
- 7. Directory Card: Inside panelboard door, mounted in metal frame with transparent protective cover.
- C. Incoming Mains Location: Top and bottom.
- D. Phase, Neutral, and Ground Buses:
 - 1. Material: Hard-drawn copper, 98 percent conductivity.
 - 2. Equipment Ground Bus: Adequate for feeder and branch-circuit equipment grounding conductors; bonded to box.
 - 3. Isolated Ground Bus: Adequate for branch-circuit isolated ground conductors; insulated from box.
 - 4. Extra-Capacity Neutral Bus: Neutral bus rated 200 percent of phase bus and UL listed as suitable for nonlinear loads.
 - 5. Split Bus: Vertical buses divided into individual vertical sections.
- E. Conductor Connectors: Suitable for use with conductor material and sizes.
 - 1. Material: Hard-drawn copper, 98 percent conductivity.
 - 2. Main and Neutral Lugs: Mechanical type.
 - 3. Ground Lugs and Bus-Configured Terminators: Mechanical type.
 - 4. Feed-Through Lugs: Mechanical type, suitable for use with conductor material. Locate at opposite end of bus from incoming lugs or main device.
 - 5. Sub-feed (Double) Lugs: Mechanical type suitable for use with conductor material. Locate at same end of bus as incoming lugs or main device.
 - 6. Gutter-Tap Lugs: Mechanical type suitable for use with conductor material. Locate at same end of bus as incoming lugs or main device.
 - 7. Extra-Capacity Neutral Lugs: Rated 200 percent of phase lugs mounted on extra-capacity neutral bus.
- F. Service Equipment Label: NRTL labeled for use as service equipment for panelboards or load centers with one or more main service disconnecting and over-current protective devices.
- G. Future Devices: Mounting brackets, bus connections, filler plates, and necessary appurtenances required for future installation of devices.
- H. Panelboard Short-Circuit Current Rating: Fully rated to interrupt symmetrical short-circuit current available at terminals. Series-connected ratings are not acceptable.

2.02 DISTRIBUTION PANELBOARDS

- A. Manufacturers: Subject to compliance with requirements, provide products by one of the following:
 - 1. Square D.
 - 2. General Electric Company.
 - 3. Cutler-Hammer.
 - 4. Siemens.
- B. Panelboards: NEMA PB 1, power and feeder distribution type.
- C. Doors: Secured with vault-type latch with tumbler lock; keyed alike.
 - 1. For doors more than 36 inches high, provide two latches, keyed alike.
- D. Mains: Circuit breaker.

- E. Branch Overcurrent Protective Devices for Circuit-Breaker Frame Sizes 125 A and Smaller: Bolt-on circuit breakers.
- F. Branch Over-current Protective Devices for Circuit-Breaker Frame Sizes Larger than 125 A: Bolt-on circuit breakers; plug-in circuit breakers where individual positive-locking device requires mechanical release for removal.
- G. Branch Over-current Protective Devices: Circuit Breaker.
- H. Contactors in Main Bus: NEMA ICS 2, Class A, mechanically held, general-purpose controller, with same short-circuit interrupting rating as panelboard.
 - 1. Internal Control-Power Source: Control-power transformer, with fused primary and secondary terminals, connected to main bus ahead of contactor connection.

2.03 LIGHTING AND APPLIANCE BRANCH-CIRCUIT PANELBOARDS

- A. Manufacturers: Subject to compliance with requirements, provide products by one of the following:
 - 1. Square D.
 - 2. General Electric Company.
 - 3. Eaton.
- B. Panelboards: NEMA PB 1, lighting and appliance branch-circuit type.
- C. Mains: Circuit breaker.
- D. Branch Over-current Protective Devices: Bolt-on circuit breakers, replaceable without disturbing adjacent units.
- E. Contactors in Main Bus: NEMA ICS 2, Class A, mechanically held, general-purpose controller, with same short-circuit interrupting rating as panelboard.
 - 1. Internal Control-Power Source: Control-power transformer, with fused primary and secondary terminals, connected to main bus ahead of contactor connection.
- F. Doors: Concealed hinges; secured with flush latch with tumbler lock; keyed alike.
- G. Column-Type Panelboards: Narrow gutter extension, with cover, to overhead junction box equipped with ground and neutral terminal buses.
- H. Panelboard Short-Circuit Current Rating: Fully rated to interrupt symmetrical short-circuit current available at terminals. Series-connected ratings are not acceptable.

2.04 ACCESSORY COMPONENTS AND FEATURES

- A. Accessory Set: Include tools and miscellaneous items required for over-current protective device test, inspection, maintenance, and operation.
- B. Portable Test Set: For testing functions of solid-state trip devices without removing from panelboard. Include relay and meter test plugs suitable for testing panelboard meters and switchboard class relays.

PART 3 - EXECUTION

3.01 EXAMINATION

- A. Receive, inspect, handle, and store panelboards according to NEMA PB 1.1.
- B. Examine panelboards before installation. Reject panelboards that are damaged or rusted or have been subjected to water saturation.

- C. Examine elements and surfaces to receive panelboards for compliance with installation tolerances and other conditions affecting performance of the Work.
- D. Proceed with installation only after unsatisfactory conditions have been corrected.

3.02 INSTALLATION

- A. Install panelboards and accessories according to NEMA PB 1.1.
- B. Equipment Mounting: Install panelboards on concrete bases, 4-inch nominal thickness.
 - 1. Install dowel rods to connect concrete base to concrete floor. Unless otherwise indicated, install dowel rods on 18-inch centers around full perimeter of base.
 - 2. For panelboards, install epoxy-coated anchor bolts that extend through concrete base and anchor into structural concrete floor.
 - 3. Place and secure anchorage devices. Use setting drawings, templates, diagrams, instructions, and directions furnished with items to be embedded.
 - 4. Install anchor bolts to elevations required for proper attachment to panelboards.
 - 5. Attach panelboard to the vertical finished or structural surface behind the panelboard.
- C. Temporary Lifting Provisions: Remove temporary lifting eyes, channels, and brackets and temporary blocking of moving parts from panelboards.
- D. Comply with mounting and anchoring requirements specified in Division 26 Section "Vibration and Seismic Controls for Electrical Systems."
- E. Mount top of trim 90 inches above finished floor unless otherwise indicated.
- F. Mount panelboard cabinet plumb and rigid without distortion of box. Mount recessed panelboards with fronts uniformly flush with wall finish and mating with back box.
- G. Install over-current protective devices and controllers not already factory installed.
 - 1. Set field-adjustable, circuit-breaker trip ranges.
- H. Install filler plates in unused spaces.
- I. Stub four 1-inch empty conduits from panelboard into accessible ceiling space or space designated to be ceiling space in the future. Stub four 1-inch empty conduits into raised floor space or below slab not on grade.
- J. Comply with NECA 1.

3.03 IDENTIFICATION

- A. Identify field-installed conductors, interconnecting wiring, and components; provide warning signs complying with Division 26 Section "Identification for Electrical Systems."
- B. Create a directory to indicate installed circuit loads after balancing panelboard loads; incorporate Owner's final room designations. Obtain approval before installing. Use a computer or typewriter to create directory; handwritten directories are not acceptable.
- C. Panelboard Nameplates: Label each panelboard with a nameplate complying with requirements for identification specified in Division 26 Section "Identification for Electrical Systems."
- D. Device Nameplates: Label each branch circuit device in distribution panelboards with a nameplate complying with requirements for identification specified in Division 26 Section "Identification for Electrical Systems."

3.04 FIELD QUALITY CONTROL

- A. Manufacturer's Field Service: Engage a factory-authorized service representative to inspect, test, and adjust components, assemblies, and equipment installations, including connections.
- B. Perform tests and inspections.
 - 1. Manufacturer's Field Service: Engage a factory-authorized service representative to inspect components, assemblies, and equipment installations, including connections, and to assist in testing.
- C. Acceptance Testing Preparation:
 - 1. Test insulation resistance for each panelboard bus, component, connecting supply, feeder, and control circuit.
 - 2. Test continuity of each circuit.
- D. Tests and Inspections:
 - 1. Perform each visual and mechanical inspection and electrical test stated in NETA Acceptance Testing Specification. Certify compliance with test parameters.
 - 2. Correct malfunctioning units on-site, where possible, and retest to demonstrate compliance; otherwise, replace with new units and retest.
 - 3. Perform the following infrared scan tests and inspections and prepare reports:
 - a. Initial Infrared Scanning: After Substantial Completion, but not more than 60 days after Final Acceptance, perform an infrared scan of each panelboard. Remove front panels so joints and connections are accessible to portable scanner.
 - b. Follow-up Infrared Scanning: Perform an additional follow-up infrared scan of each panelboard 11 months after date of Substantial Completion.
 - c. Instruments and Equipment:
 - (1) Use an infrared scanning device designed to measure temperature or to detect significant deviations from normal values. Provide calibration record for device.
- E. Panelboards will be considered defective if they do not pass tests and inspections.
- F. Prepare test and inspection report, including a certified report that identifies panelboards included and that describes scanning results. Include notation of deficiencies detected, remedial action taken, and observations after remedial action.

3.05 ADJUSTING

- A. Adjust moving parts and operable component to function smoothly, and lubricate as recommended by manufacturer.
- B. Set field-adjustable circuit-breaker trip ranges as indicated.
- C. Load Balancing: After Substantial Completion, but not more than 60 days after Final Acceptance, measure load balancing and make circuit changes.
 - 1. Measure as directed during period of normal system loading.
 - 2. Perform load-balancing circuit changes outside normal occupancy/working schedule of the facility and at time directed. Avoid disrupting critical 24-hour services such as fax machines and on-line data processing, computing, transmitting, and receiving equipment.
 - 3. After circuit changes, recheck loads during normal load period. Record all load readings before and after changes and submit test records.
 - 4. Tolerance: Difference exceeding 20 percent between phase loads, within a panelboard, is not acceptable. Rebalance and recheck as necessary to meet this minimum requirement.

3.06 PROTECTION

- A. Temporary Heating: Apply temporary heat to maintain temperature according to manufacturer's written instructions.

END OF SECTION

SECTION 262726 - WIRING DEVICES

PART 1 - GENERAL

1.01 RELATED DOCUMENTS

- A. Drawings and general provisions of the Contract, including General and Supplementary Conditions and Division 01 Specification Sections, apply to this Section.

1.02 SUMMARY

- A. This Section includes the following:
 - 1. Receptacles, receptacles with integral GFCI, and associated device plates.
 - 2. Twist-locking receptacles.
 - 3. Receptacles with integral surge suppression units.
 - 4. Hospital Grade
 - 5. Wall-box motion sensors.
 - 6. Isolated-ground receptacles.
 - 7. Snap switches and wall-box dimmers.
 - 8. Wall-switch and exterior occupancy sensors.
 - 9. Communications outlets.
 - 10. Pendant cord-connector devices.
 - 11. Cord and plug sets.
 - 12. Floor service outlets, poke-through assemblies, service poles, and multi-outlet assemblies.

1.03 DEFINITIONS

- A. EMI: Electromagnetic interference.
- B. GFCI: Ground-fault circuit interrupter.
- C. Pigtail: Short lead used to connect a device to a branch-circuit conductor.
- D. RFI: Radio-frequency interference.
- E. TVSS: Transient voltage surge suppressor.
- F. UTP: Unshielded twisted pair.

1.04 SUBMITTALS

- A. Product Data: For each type of product indicated.
- B. Shop Drawings: List of legends and description of materials and process used for pre-marking wall plates.
- C. Samples: One for each type of device and wall plate specified, in each color specified.
- D. Field quality-control test reports.
- E. Operation and Maintenance Data: For wiring devices to include in all manufacturers' packing label warnings and instruction manuals that include labeling conditions.

1.05 QUALITY ASSURANCE

- A. Source Limitations: Obtain each type of wiring device and associated wall plate through one source from a single manufacturer. Insofar as they are available, obtain all wiring devices and associated wall plates from a single manufacturer and one source.
- B. Electrical Components, Devices, and Accessories: Listed and labeled as defined in NFPA 70, Article 100, by a testing agency acceptable to authorities having jurisdiction, and marked for intended use.
- C. Comply with NFPA 70.

1.06 COORDINATION

- A. Receptacles for Owner-Furnished Equipment: Match plug configuration.
 - 1. Cord and Plug Sets: Match equipment requirements.

1.07 EXTRA MATERIALS

- A. Furnish extra materials described in subparagraphs below that match products installed and that are packaged with protective covering for storage and identified with labels describing contents.
 - 1. Service/Power Poles: One for every 10, but no less than one.
 - 2. Floor Service Outlet Assemblies: One for every 10 but no less than one.
 - 3. Poke-Through, Fire-Rated Closure Plugs: One for every five floor service outlets installed, but no fewer than two.
 - 4. TVSS Receptacles: One for every 10 of each type installed, but no fewer than two of each type.

PART 2 - PRODUCTS

2.01 MANUFACTURERS

- A. Manufacturers' Names: Shortened versions (shown in parentheses) of the following manufacturers' names are used in other Part 2 articles:
 - 1. Pass & Seymour/Legrand
 - 2. Hubbell Incorporated; Wiring Device-Kellems (Hubbell).
 - 3. Leviton Mfg. Company Inc. (Leviton).
 - 4. Watt Stopper

2.02 STRAIGHT BLADE RECEPTACLES

- A. Convenience Receptacles, 125 V, 20 A: Comply with NEMA WD 1, NEMA WD 6 configuration 5-20R, and UL 498.
 - 1. Products: Subject to compliance with requirements, provide one of the following:
 - a. Pass & Seymour/Legrand ; 5381 (single), 5352 (duplex).
 - b. Hubbell; HBL5351 (single), CR5352 (duplex).
 - c. Leviton; 5891 (single), 5352 (duplex).
- B. Hospital-Grade, Duplex Convenience Receptacles, 125 V, 20 A: Comply with NEMA WD 1, NEMA WD 6 configuration 5-20R, and UL 498 Supplement SD.
 - 1. Products: Subject to compliance with requirements, provide one of the following:
 - a. Pass & Seymour/Legrand; 9301-HG (single), 9300-HG (duplex).

- b. Hubbell; HBL8310 (single), HBL8300H (duplex).
 - c. Leviton; 8310 (single), 8300 (duplex).
- C. Isolated-Ground, Duplex Convenience Receptacles, 125 V, 20 A: Comply with NEMA WD 1, NEMA WD 6 configuration 5-20R, and UL 498.
 - 1. Products: Subject to compliance with requirements, provide one of the following:
 - a. Hubbell; CR 5253IG.
 - b. Leviton; 5362-IG.
 - c. Pass & Seymour; IG6300.
 - 2. Description: Straight blade; equipment grounding contacts shall be connected only to the green grounding screw terminal of the device and with inherent electrical isolation from mounting strap. Isolation shall be integral to receptacle construction and not dependent on removable parts.
- D. Tamper-Resistant Convenience Receptacles, 125 V, 20 A: Comply with NEMA WD 1, NEMA WD 6 configuration 5-20R, and UL 498.
 - 1. Products: Subject to compliance with requirements, provide one of the following:
 - a. Pass & Seymour; 63H
 - b. Hubbell; HBL8300SG.
 - c. Leviton; 8300-SGG.
 - 2. Description: Labeled to comply with NFPA 70, "Health Care Facilities" Article, "Pediatric Locations" Section.

2.03 GFCI RECEPTACLES

- A. General Description: Straight blade, feed-through type. Comply with NEMA WD 1, NEMA WD 6, UL 498, and UL 943, Class A, and include indicator light that is lighted when device is tripped.
- B. Duplex GFCI Convenience Receptacles, 125 V, 20 A:
 - 1. Products: Subject to compliance with requirements, provide one of the following:
 - a. Pass & Seymour/Legrand; 2084.
- C. Hospital-Grade, Duplex GFCI Convenience Receptacles, 125 V, 20 A: Comply with UL 498 Supplement SD.
 - 1. Products: Subject to compliance with requirements, provide one of the following:
 - a. Pass & Seymour/Legrand; 2091-SHG.
 - b. Hubbell; HGF8300.
 - c. Leviton; 6898-HG.

2.04 TVSS RECEPTACLES

- A. General Description: Comply with NEMA WD 1, NEMA WD 6, UL 498, and UL 1449, with integral TVSS in line to ground, line to neutral, and neutral to ground.
 - 1. TVSS Components: Multiple metal-oxide varistors; with a nominal clamp-level rating of 400 volts and minimum single transient pulse energy dissipation of 240 J, according to IEEE C62.41.2 and IEEE C62.45.
 - 2. Active TVSS Indication: Visual and audible, with light visible in face of device to indicate device is "active" or "no longer in service."
- B. Duplex TVSS Convenience Receptacles:

1. Products: Subject to compliance with requirements, provide one of the following:
 - a. Pass & Seymour/Legrand
 - b. Hubbell; HBL5362SA.
 - c. Leviton; 5380.
 2. Description: Straight blade, 125 V, 20 A; NEMA WD 6 configuration 5-20R.
- C. Isolated-Ground, Duplex Convenience Receptacles:
1. Available Products: Subject to compliance with requirements, products that may be incorporated into the Work include, but are not limited to, the following:
 2. Products: Subject to compliance with requirements, provide one of the following:
 - a. Pass & Seymour/Legrand
 - b. Hubbell; IG5362SA.
 3. Leviton; 5380-IG.
 4. Description: Straight blade, 125 V, 20 A; NEMA WD 6 configuration 5-20R. Equipment grounding contacts shall be connected only to the green grounding screw terminal of the device and with inherent electrical isolation from mounting strap. Isolation shall be integral to receptacle construction and not dependent on removable parts.
- D. Hospital-Grade, Duplex Convenience Receptacles: Comply with UL 498 Supplement SD.
1. Products: Subject to compliance with requirements, provide one of the following:
 - a. Pass & Seymour/Legrand
 - b. Hubbell; HBL8362SA.
 - c. Leviton; 8380.
 2. Description: Straight blade, 125 V, 20 A; NEMA WD 6 configuration 5-20R.
- E. Isolated-Ground, Hospital-Grade, Duplex Convenience Receptacles:
1. Products: Subject to compliance with requirements, provide one of the following:
 - a. Pass & Seymour/Legrand
 - b. Hubbell; IG8362SA.
 2. Leviton; 8380-IG.
 3. Description: Straight blade, 125 V, 20 A; NEMA WD 6 configuration 5-20R. Comply with UL 498 Supplement SD. Equipment grounding contacts shall be connected only to the green grounding screw terminal of the device and with inherent electrical isolation from mounting strap. Isolation shall be integral to receptacle construction and not dependent on removable parts.

2.05 HAZARDOUS (CLASSIFIED) LOCATION RECEPTACLES

- A. Wiring Devices for Hazardous (Classified) Locations: Comply with NEMA FB 11 and UL 1010.
1. Manufacturers: Subject to compliance with requirements, provide products by one of the following:
 - a. Cooper Crouse-Hinds.
 - b. EGS/Appleton Electric.
 - c. Killark; a division of Hubbell Inc.

2.06 TWIST-LOCKING RECEPTACLES

- A. Single Convenience Receptacles, 125 V, 20 A: Comply with NEMA WD 1, NEMA WD 6 configuration L5-20R, and UL 498.
 - 1. Products: Subject to compliance with requirements, provide one of the following:
 - a. Pass & Seymour/Legrand; L520-R.
 - b. Hubbell; HBL2310.
 - c. Leviton; 2310.
- B. Isolated-Ground, Single Convenience Receptacles, 125 V, 20 A:
 - 1. Products: Subject to compliance with requirements, provide one of the following:
 - a. Hubbell; IG2310.
 - b. Leviton; 2310-IG.
 - c. Pass & Seymour/Legrand
 - 2. Description: Comply with NEMA WD 1, NEMA WD 6 configuration L5-20R, and UL 498. Equipment grounding contacts shall be connected only to the green grounding screw terminal of the device and with inherent electrical isolation from mounting strap. Isolation shall be integral to receptacle construction and not dependent on removable parts.

2.07 PENDANT CORD-CONNECTOR DEVICES

- A. Description: Matching, locking-type plug and receptacle body connector; NEMA WD 6 configurations L5-20P and L5-20R, heavy-duty grade.
 - 1. Body: Nylon with screw-open cable-gripping jaws and provision for attaching external cable grip.
 - 2. External Cable Grip: Woven wire-mesh type made of high-strength galvanized-steel wire strand, matched to cable diameter, and with attachment provision designed for corresponding connector.

2.08 CORD AND PLUG SETS

- A. Description: Match voltage and current ratings and number of conductors to requirements of equipment being connected.
 - 1. Cord: Rubber-insulated, stranded-copper conductors, with Type SOW-A jacket; with green-insulated grounding conductor and equipment-rating ampacity plus a minimum of 30 percent.
 - 2. Plug: Nylon body and integral cable-clamping jaws. Match cord and receptacle type for connection.

2.09 SNAP SWITCHES

- A. Comply with NEMA WD 1 and UL 20.
- B. Switches, 120/277 V, 20 A:
 - 1. Products: Subject to compliance with requirements, provide one of the following:
 - a. Pass & Seymour/Legrand; 20AC1 (single pole), 20AC2 (two pole), 20AC3 (three way), 20AC4 (four way).
 - b. Hubbell; CS1221 (single pole), CS1222 (two pole), CS1223 (three way), CS1224 (four way).
 - c. Leviton; 1221-2 (single pole), 1222-2 (two pole), 1223-2 (three way), 1224-2 (four way).

- C. Pilot Light Switches, 20 A:
 - 1. Products: Subject to compliance with requirements, provide one of the following:
 - a. Pass & Seymour/Legrand; PS20AC1-PLR for 120 V.
 - b. Hubbell; HPL1221PL for 120 V and 277 V.
 - c. Leviton; 1221-PLR for 120 V, 1221-7PLR for 277 V.
 - 2. Description: Single pole, with neon-lighted handle, illuminated when switch is "ON."
- D. Key-Operated Switches, 120/277 V, 20 A:
 - 1. Products: Subject to compliance with requirements, provide one of the following:
 - a. Pass & Seymour/Legrand; PS20AC1-L.
 - b. Hubbell; HBL1221L.
 - c. Leviton; 1221-2L.
 - 2. Description: Single pole, with factory-supplied key in lieu of switch handle.
- E. Single-Pole, Double-Throw, Momentary Contact, Center-Off Switches, 120/277 V, 20 A; for use with mechanically held lighting contactors.
 - 1. Products: Subject to compliance with requirements, provide one of the following:
 - a. Pass & Seymour/Legrand; 1251.
 - b. Hubbell; HBL1557.
 - c. Leviton; 1257.
- F. Key-Operated, Single-Pole, Double-Throw, Momentary Contact, Center-Off Switches, 120/277 V, 20 A; for use with mechanically held lighting contactors, with factory-supplied key in lieu of switch handle.
 - 1. Products: Subject to compliance with requirements, provide one of the following:
 - a. Pass & Seymour/Legrand; 1251L.
 - b. Hubbell; HBL1557L.
 - c. Leviton; 1257L.

2.10 WALL-BOX DIMMERS

- A. Dimmer Switches: Modular, full-wave, solid-state units with integral, quiet on-off switches, with audible frequency and EMI/RFI suppression filters.
- B. Control: Continuously adjustable slider; with single-pole or three-way switching. Comply with UL 1472.
- C. Incandescent Lamp Dimmers: 120 V; control shall follow square-law dimming curve. On-off switch positions shall bypass dimmer module.
- D. Fluorescent Lamp Dimmer Switches: Modular; compatible with dimmer ballasts; trim potentiometer to adjust low-end dimming; dimmer-ballast combination capable of consistent dimming with low end not greater than 20 percent of full brightness.

2.11 OCCUPANCY SENSORS

- A. Wall-Switch Sensors:
 - 1. Products: Subject to compliance with requirements, provide one of the following:
 - a. Pass & Seymour/Legrand; WS3000.
 - b. Hubbell; WS1277.

- c. Leviton; ODS 10-ID.
 - d. Watt Stopper: WS-250
 - (1) Line voltage: WS-250
 - e. Watt Stopper
2. Description: Passive-infrared type, 120/277 V, adjustable time delay up to 30 minutes, 180-degree field of view, with a minimum coverage area of 900 sq. ft.
- B. Long-Range Wall-Switch Sensors:
- 1. Products: Subject to compliance with requirements, provide one of the following:
 - a. Hubbell; ATP1600WRP.
 - b. Leviton; ODWWV-IRW.
 - c. Pass & Seymour; WA1001.
 - d. Watt Stopper (The); CX-100.
 - 2. Description: Passive-infrared type, 120/277 V, adjustable time delay up to 30 minutes, 110-degree field of view, with a minimum coverage area of 1200 sq. ft.
- C. Wide-Range Wall-Switch Sensors:
- 1. Products: Subject to compliance with requirements, provide one of the following:
 - a. Hubbell; ATP120HBRP.
 - b. Leviton; ODWHB-IRW.
 - c. Pass & Seymour; HS1001.
 - d. Watt Stopper (The); CX-100-3.
 - 2. Description: Passive-infrared type, 120/277 V, adjustable time delay up to 30 minutes, 150-degree field of view, with a minimum coverage area of 1200 sq. ft.
- D. Ceiling-Mounted Dual-Technology (PIR/Ultrasound) Sensors:
- 1. Products: Subject to compliance with requirements, provide one of the following:
 - a. Hubbell; XXXX.
 - b. Leviton; ODC-20.
 - c. Pass & Seymour; XXXX.
 - d. Watt Stopper: LMDC100 and LMRC-102
 - 2. Description: Passive-infrared type, 120/277 V, adjustable time delay up to 30 minutes, 150-degree field of view, with a minimum coverage area of 1200 sq. ft.
- E. Exterior Occupancy Sensors:
- 1. Products: Subject to compliance with requirements, provide one of the following:
 - a. Leviton; PS200-10.
 - b. Watt Stopper (The); EW-100-120.
 - c. Pass & Seymour/Legrand
 - 2. Description: Passive-infrared type, 120/277 V, weatherproof, adjustable time delay up to 15 minutes, 180-degree field of view, and 110-foot detection range. Minimum switch rating: 1000-W incandescent, 500-VA fluorescent.

2.12 COMMUNICATIONS OUTLETS

- A. Telephone Outlet:
- 1. Products: Subject to compliance with requirements, provide one of the following:

- a. Cooper; 3560-6.
- b. Leviton; 40649.
- 2. Description: Single RJ-45 jack for terminating 100-ohm, balanced, four-pair UTP; TIA/EIA-568-B.1; complying with Category 5e. Comply with UL 1863.
- B. Combination TV and Telephone Outlet:
 - 1. Products: Subject to compliance with requirements, provide one of the following:
 - a. Cooper; 3562.
 - b. Leviton; 40595.
 - 2. Description: Single RJ-45 jack for 100-ohm, balanced, four-pair UTP; TIA/EIA-568-B.1; complying with Category 5e; and one Type F coaxial cable connector.

2.13 WALL PLATES

- A. Single and combination types to be 302/304 stainless steel.
- B. Wet-Location, Weatherproof Cover Plates: NEMA 250, complying with type 3R weather-resistant thermoplastic with lockable cover.

2.14 FLOOR SERVICE FITTINGS

- A. Type: Modular, flush-type, dual-service units suitable for wiring method used.
- B. Compartments: Barrier separates power from voice and data communication cabling.
- C. Service Plate: Rectangular, solid brass with satin finish.
- D. Power Receptacle: NEMA WD 6 configuration 5-20R, gray finish, unless otherwise indicated.
- E. Voice and Data Communication Outlet: Blank cover with bushed cable opening.

2.15 POKE-THROUGH ASSEMBLIES

- A. Available Manufacturers: Subject to compliance with requirements, manufacturers offering products that may be incorporated into the Work include, but are not limited to, the following:
- B. Manufacturers: Subject to compliance with requirements, provide products by one of the following:
 - 1. Hubbell Incorporated; Wiring Device-Kellems.
 - 2. Pass & Seymour/Legrand; Wiring Devices & Accessories.
 - 3. Square D/ Schneider Electric.
 - 4. Thomas & Betts Corporation.
 - 5. Wiremold Company (The).
- C. Description: Factory-fabricated and -wired assembly of below-floor junction box with multi-channeled, through-floor raceway/fire-stop unit and detachable matching floor service outlet assembly.
 - 1. Service Outlet Assembly: Pedestal type with services indicated.
 - 2. Size: Selected to fit nominal 3-inch cored holes in floor and matched to floor thickness.
 - 3. Fire Rating: Unit is listed and labeled for fire rating of floor-ceiling assembly.
 - 4. Closure Plug: Arranged to close unused 3-inch cored openings and reestablish fire rating of floor.
 - 5. Wiring Raceways and Compartments: For a minimum of four No. 12 AWG conductors and a minimum of four, 4-pair, Category 5e voice and data communication cables.

2.16 MULTIOUTLET ASSEMBLIES

- A. Manufacturers: Subject to compliance with requirements, provide products by one of the following:
 - 1. Hubbell Incorporated; Wiring Device-Kellems.
 - 2. Wiremold Company (The).
- B. Components of Assemblies: Products from a single manufacturer designed for use as a complete, matching assembly of raceways and receptacles.
- C. Raceway Material: Metal, with manufacturer's standard finish.
- D. Wire: No. 12 AWG.

2.17 SERVICE POLES

- A. Description: Factory-assembled and -wired units to extend power and voice and data communication from distribution wiring concealed in ceiling to devices or outlets in pole near floor.
 - 1. Poles: Nominal 2.5-inch square cross section, with height adequate to extend from floor to at least 6 inches above ceiling, and with separate channels for power wiring and voice and data communication cabling.
 - 2. Mounting: Ceiling trim flange with concealed bracing arranged for positive connection to ceiling supports; with pole foot and carpet pad attachment.
 - 3. Finishes: Manufacturer's standard painted finish and trim combination.
 - 4. Wiring: Sized for minimum of five No. 12 AWG power and ground conductors and a minimum of four, 4-pair, Category 3 or 5 voice and data communication cables.
 - 5. Power Receptacles: Two duplex, 20-A, heavy-duty, NEMA WD 6 configuration 5-20R units.
 - 6. Voice and Data Communication Outlets: Blank insert with bushed cable opening.

2.18 FINISHES

- A. Color: Wiring device catalog numbers in Section Text do not designate device color.
 - 1. Wiring Devices Connected to Normal Power System: Ivory, or as selected by Architect unless otherwise indicated or required by NFPA 70 or device listing.
 - 2. Wiring Devices Connected to Emergency Power System: Red.
 - 3. TVSS Devices: Blue.
 - 4. Isolated-Ground Receptacles: Orange.

PART 3 - EXECUTION

3.01 INSTALLATION

- A. Comply with NECA 1, including the mounting heights listed in that standard, unless otherwise noted.
- B. Coordination with Other Trades:
 - 1. Take steps to insure that devices and their boxes are protected. Do not place wall finish materials over device boxes and do not cut holes for boxes with routers that are guided by riding against outside of the boxes.
 - 2. Keep outlet boxes free of plaster, drywall joint compound, mortar, cement, concrete, dust, paint, and other material that may contaminate the raceway system, conductors, and cables.

3. Install device boxes in brick or block walls so that the cover plate does not cross a joint unless the joint is troweled flush with the face of the wall.
 4. Install wiring devices after all wall preparation, including painting, is complete.
- C. Conductors:
1. Do not strip insulation from conductors until just before they are spliced or terminated on devices.
 2. Strip insulation evenly around the conductor using tools designed for the purpose. Avoid scoring or nicking of solid wire or cutting strands from stranded wire.
 3. The length of free conductors at outlets for devices shall meet provisions of NFPA 70, Article 300, without pigtails.
 4. Existing Conductors:
 - a. Cut back and pigtail, or replace all damaged conductors.
 - b. Straighten conductors that remain and remove corrosion and foreign matter.
 - c. Pigtailing existing conductors is permitted provided the outlet box is large enough.
- D. Device Installation:
1. Replace all devices that have been in temporary use during construction or that show signs that they were installed before building finishing operations were complete.
 2. Keep each wiring device in its package or otherwise protected until it is time to connect conductors.
 3. Do not remove surface protection, such as plastic film and smudge covers, until the last possible moment.
 4. Connect devices to branch circuits using pigtails that are not less than 6 inches in length.
 5. Provide devices utilizing compression type connections.
 6. When there is a choice, use side wiring with binding-head screw terminals. Wrap solid conductor tightly clockwise, 2/3 to 3/4 of the way around terminal screw.
 7. Use a torque screwdriver when a torque is recommended or required by the manufacturer.
 8. When conductors larger than No. 12 AWG are installed on 15- or 20-A circuits, splice No. 12 AWG pigtails for device connections.
 9. Tighten unused terminal screws on the device.
 10. When mounting into metal boxes, remove the fiber or plastic washers used to hold device mounting screws in yokes, allowing metal-to-metal contact.
 11. Heights are measured above finished floor to midpoint of device boxes, unless otherwise noted. Install devices at the mounting heights prescribed in the following table.

<u>DEVICE</u>	<u>MOUNTING HEIGHT</u>
Wall Switch/Temperature, CO2, Humidity Sensors	48"
Wall Receptacle	18"
Wall Telecom Outlet	18"
Wall Phone, Pay Phone	48"
Panelboards	72" aff to top of box
Starter, Disconnect	66" aff to midpoint of box
Countertop Receptacles, Outlets	8" above counter to midpoint of box

12. Electrical contractor is responsible for all temperature, CO₂, and Humidity sensor stub-ups for the mechanical HVAC system. Refer to mechanical prints for sensor quantity and locations.

E. Receptacle Orientation:

1. Install ground pin of vertically mounted receptacles up, and on horizontally mounted receptacles to the right.
2. Install hospital-grade receptacles in patient-care areas with the ground pin or neutral blade at the top.

F. Device Plates: Do not use oversized or extra-deep plates. Repair wall finishes and remount outlet boxes when standard device plates do not fit flush or do not cover rough wall opening.

G. Dimmers:

1. Install dimmers within terms of their listing.
2. Verify that dimmers used for fan speed control are listed for that application.
3. Install unshared neutral conductors on line and load side of dimmers according to manufacturers' device listing conditions in the written instructions.

H. Arrangement of Devices: Unless otherwise indicated, mount flush, with long dimension vertical and with grounding terminal of receptacles on top. Group adjacent switches under single, multi-gang wall plates.

I. Adjust locations of floor service outlets and service poles to suit arrangement of partitions and furnishings.

3.02 IDENTIFICATION

A. Comply with Division 26 Section "Identification for Electrical Systems."

1. Receptacles: Identify panelboard and circuit number from which served. Use hot, stamped or engraved machine printing with black-filled lettering on face of plate, and durable wire markers or tags inside outlet boxes.

3.03 FIELD QUALITY CONTROL

A. Perform tests and inspections and prepare test reports.

1. In healthcare facilities, prepare reports that comply with recommendations in NFPA 99.
2. Test Instruments: Use instruments that comply with UL 1436.
3. Test Instrument for Convenience Receptacles: Digital wiring analyzer with digital readout or illuminated LED indicators of measurement.

B. Tests for Convenience Receptacles:

1. Line Voltage: Acceptable range is 105 to 132 V.
2. Percent Voltage Drop under 15-A Load: A value of 6 percent or higher is not acceptable.
3. Ground Impedance: Values of up to 2 ohms are acceptable.
4. GFCI Trip: Test for tripping values specified in UL 1436 and UL 943.
5. Using the test plug, verify that the device and its outlet box are securely mounted.
6. The tests shall be diagnostic, indicating damaged conductors, high resistance at the circuit breaker, poor connections, inadequate fault current path, defective devices, or similar problems. Correct circuit conditions, remove malfunctioning units and replace with new ones, and retest as specified above.

END OF SECTION

SECTION 262813 - FUSES

PART 1 - GENERAL

1.01 RELATED DOCUMENTS

- A. Drawings and general provisions of the Contract, including General and Supplementary Conditions and Division 01 Specification Sections, apply to this Section.

1.02 SUMMARY

- A. Section Includes:
 1. Cartridge fuses rated 600-V ac and less for use in control circuits, enclosed switches, panelboards, switchboards, enclosed controllers, and motor-control centers.
 2. Plug fuses rated 125-V ac and less for use in plug-fuse-type enclosed switches, fuseholders, and panelboards.
 3. Retain first subparagraph below if retaining rejection-base-type plug fuses and if Project contains fuseholders with Edison-base, plug-fuse sockets.
 4. Plug-fuse adapters for use in Edison-base, plug-fuse sockets.
 5. Spare-fuse cabinets.

1.03 SUBMITTALS

- A. Product Data: For each type of product indicated. Include construction details, material, dimensions, descriptions of individual components, and finishes for spare-fuse cabinets. Include the following for each fuse type indicated:
 1. Ambient Temperature Adjustment Information: If ratings of fuses have been adjusted to accommodate ambient temperatures, provide list of fuses with adjusted ratings.
 - a. For each fuse having adjusted ratings, include location of fuse, original fuse rating, local ambient temperature, and adjusted fuse rating.
 - b. Provide manufacturer's technical data on which ambient temperature adjustment calculations are based.
 2. Dimensions and manufacturer's technical data on features, performance, electrical characteristics, and ratings.
 3. Current-limitation curves for fuses with current-limiting characteristics.
 4. Time-current coordination curves (average melt) and current-limitation curves (instantaneous peak let-through current) for each type and rating of fuse.
 5. Coordination charts and tables and related data.
 6. Fuse sizes for elevator feeders and elevator disconnect switches.
- B. Operation and Maintenance Data: For fuses to include in emergency, operation, and maintenance manuals. In addition to items specified in Division 01 Section "Operation and Maintenance Data," include the following:
 1. Ambient temperature adjustment information.
 2. Current-limitation curves for fuses with current-limiting characteristics.
 3. Time-current coordination curves (average melt) and current-limitation curves (instantaneous peak let-through current) for each type and rating of fuse.

4. Coordination charts and tables and related data.

1.04 QUALITY ASSURANCE

- A. Source Limitations: Obtain fuses, for use within a specific product or circuit, from single source from single manufacturer.
- B. Electrical Components, Devices, and Accessories: Listed and labeled as defined in NFPA 70, by a qualified testing agency, and marked for intended location and application.
- C. Comply with NEMA FU 1 for cartridge fuses.
- D. Comply with NFPA 70.
- E. Comply with UL 248-11 for plug fuses.

1.05 COORDINATION

- A. Coordinate fuse ratings with utilization equipment nameplate limitations of maximum fuse size and with system short-circuit current levels.

1.06 EXTRA MATERIALS

- A. Furnish extra materials that match products installed and that are packaged with protective covering for storage and identified with labels describing contents.

PART 2 - PRODUCTS

2.01 MANUFACTURERS

- A. Manufacturers: Subject to compliance with requirements, provide products by one of the following:
 - 1. Cooper Bussmann, Inc.
 - 2. Littlefuse, Inc.

2.02 SAFETY SWITCH FUSES

- A. Provide fuse Class and Type as indicated on One Line Diagram. If not specifically indicated, provide Dual Element Time Delay (DETD) type, Class RK1 rejection fuses.
- B. Provide rejection kits as required for Class RK1 and RK5 fuses.

2.03 CARTRIDGE FUSES

- A. Characteristics: NEMA FU 1, nonrenewable cartridge fuses with voltage ratings consistent with circuit voltages.

2.04 PLUG FUSES

- A. Characteristics: UL 248-11, nonrenewable plug fuses; 125-V ac.

2.05 PLUG-FUSE ADAPTERS

- A. Characteristics: Adapters for using Type S, rejection-base plug fuses in Edison-base fuse-holders or sockets; ampere ratings matching fuse ratings; irremovable once installed.

PART 3 - EXECUTION

3.01 EXAMINATION

- A. Examine fuses before installation. Reject fuses that are moisture damaged or physically damaged.

- B. Examine holders to receive fuses for compliance with installation tolerances and other conditions affecting performance, such as rejection features.
- C. Examine utilization equipment nameplates and installation instructions. Install fuses of sizes and with characteristics appropriate for each piece of equipment.
- D. Evaluate ambient temperatures to determine if fuse rating adjustment factors must be applied to fuse ratings.
- E. Proceed with installation only after unsatisfactory conditions have been corrected.

3.02 FUSE APPLICATIONS

- A. Cartridge Fuses:
 - 1. Service Entrance: Class L, fast acting.
 - 2. Feeders: Class L, fast acting
 - 3. Motor Branch Circuits: Class RK1 and Class RK5, time delay.
 - 4. Other Branch Circuits: Class J, fast acting.
 - 5. Control Circuits: Class CC, fast acting.

3.03 INSTALLATION

- A. Install fuses in fusible devices. Arrange fuses so rating information is readable without removing fuse.
- B. Install plug-fuse adapters in Edison-base fuse-holders and sockets. Ensure that adapters are irremovable once installed.
- C. Install spare-fuse cabinet(s).

3.04 IDENTIFICATION

- A. Install labels complying with requirements for identification specified in Division 26 Section "Identification for Electrical Systems" and indicating fuse replacement information on inside door of each fused switch and adjacent to each fuse block, socket, and holder.

END OF SECTION

SECTION 262816 - ENCLOSED SWITCHES AND CIRCUIT BREAKERS

PART 1 - GENERAL

1.01 RELATED DOCUMENTS

- A. Drawings and general provisions of the Contract, including General and Supplementary Conditions and other Division 01 Specification Sections, apply to this Section.

1.02 SUMMARY

- A. Section Includes:
 1. Fusible switches.
 2. Non-fusible switches.
 3. Receptacle switches.
 4. Shunt trip switches.
 5. Molded-case circuit breakers.
 6. Enclosures.

1.03 DEFINITIONS

- A. NC: Normally closed.
- B. NO: Normally open.
- C. SPDT: Single pole, double throw.

1.04 SUBMITTALS

- A. Product Data: For each type of enclosed switch, circuit breaker, accessory, and component indicated. Include dimensioned elevations, sections, weights, and manufacturers' technical data on features, performance, electrical characteristics, ratings, accessories, and finishes.
 1. Enclosure types and details for types other than NEMA 250, Type 1.
 2. Current and voltage ratings.
 3. Short-circuit current ratings (interrupting and withstand, as appropriate).
 4. Detail features, characteristics, ratings, and factory settings of individual over-current protective devices, accessories, and auxiliary components.
 5. Include time-current coordination curves (average melt) for each type and rating of over-current protective device; include selectable ranges for each type of over-current protective device.
- B. Shop Drawings: For enclosed switches and circuit breakers. Include plans, elevations, sections, details, and attachments to other work.
 1. Wiring Diagrams: For power, signal, and control wiring.
- C. Qualification Data: For qualified testing agency.
- D. Seismic Qualification Certificates: For enclosed switches and circuit breakers, accessories, and components, from manufacturer.
 1. Basis for Certification: Indicate whether withstand certification is based on actual test of assembled components or on calculation.
 2. Dimensioned Outline Drawings of Equipment Unit: Identify center of gravity and locate

- and describe mounting and anchorage provisions.
3. Detailed description of equipment anchorage devices on which the certification is based and their installation requirements.
- E. Field quality-control reports.
1. Test procedures used.
 2. Test results that comply with requirements.
 3. Results of failed tests and corrective action taken to achieve test results that comply with requirements.
- F. Manufacturer's field service report.
- G. Operation and Maintenance Data: For enclosed switches and circuit breakers to include in emergency, operation, and maintenance manuals. In addition to items specified in Division 01 Section "Operation and Maintenance Data," include the following:
1. Manufacturer's written instructions for testing and adjusting enclosed switches and circuit breakers.
 2. Time-current coordination curves (average melt) for each type and rating of over-current protective device; include selectable ranges for each type of over-current protective device.

1.05 QUALITY ASSURANCE

- A. Source Limitations: Obtain enclosed switches and circuit breakers, over-current protective devices, components, and accessories, within same product category, from single source from single manufacturer.
- B. Product Selection for Restricted Space: Drawings indicate maximum dimensions for enclosed switches and circuit breakers, including clearances between enclosures, and adjacent surfaces and other items. Comply with indicated maximum dimensions.
- C. Electrical Components, Devices, and Accessories: Listed and labeled as defined in NFPA 70, by a qualified testing agency, and marked for intended location and application.
- D. Comply with NFPA 70.

1.06 COORDINATION

- A. Coordinate layout and installation of switches, circuit breakers, and components with equipment served and adjacent surfaces. Maintain required workspace clearances and required clearances for equipment access doors and panels.

1.07 EXTRA MATERIALS

- A. Furnish extra materials that match products installed and that are packaged with protective covering for storage and identified with labels describing contents.
1. Fuses: Equal to 10 percent of quantity installed for each size and type, but no fewer than three of each size and type.
 2. Fuse Pullers: Two for each size and type.

PART 2 - PRODUCTS

2.01 FUSIBLE SWITCHES

- A. Manufacturers: Subject to compliance with requirements, provide products by one of the following:
1. Square D.

2. Cutler-Hammer
 3. GE
 4. Siemens
- B. Type HD, Heavy Duty, Six Pole, Single Throw, 600-V ac, 200 A and Smaller: UL 98 and NEMA KS 1, horsepower rated, with clips or bolt pads to accommodate indicated fuses, lockable handle with capability to accept three padlocks, and interlocked with cover in closed position.
- C. Type HD, Heavy Duty, Double Throw, 600-V ac, 1200 A and Smaller: UL 98 and NEMA KS 1, horsepower rated, with clips or bolt pads to accommodate indicated fuses, lockable handle with capability to accept three padlocks, and interlocked with cover in closed position.
- D. Accessories:
1. Equipment Ground Kit: Internally mounted and labeled for copper and aluminum ground conductors.
 2. Neutral Kit: Internally mounted; insulated, capable of being grounded and bonded; labeled for copper and aluminum neutral conductors.
 3. Isolated Ground Kit: Internally mounted; insulated, capable of being grounded and bonded; labeled for copper and aluminum neutral conductors.
 4. Class R Fuse Kit: Provides rejection of other fuse types when Class R fuses are specified.
 5. Auxiliary Contact Kit: Two NO/NC (Form "C") auxiliary contact(s), arranged to activate before switch blades open.
 6. Hook stick Handle: Allows use of a hook stick to operate the handle.
 7. Lugs: Mechanical type, suitable for number, size, and conductor material.
 8. Service-Rated Switches: Labeled for use as service equipment.
 9. Accessory Control Power Voltage: Remote mounted and powered; 120-V ac.

2.02 NONFUSIBLE SWITCHES

- A. Manufacturers: Subject to compliance with requirements, provide products by one of the following:
1. Square D.
 2. Cutler-Hammer
 3. GE
 4. Siemens
- B. Type HD, Heavy Duty, Single Throw, 240, 600-V ac, 1200 A and Smaller: UL 98 and NEMA KS 1, horsepower rated, lockable handle with capability to accept three padlocks, and interlocked with cover in closed position.
- C. Type HD, Heavy Duty, Six Pole, Single Throw, 240, 600-V ac, 200 A and Smaller: UL 98 and NEMA KS 1, horsepower rated, lockable handle with capability to accept three padlocks, and interlocked with cover in closed position.
- D. Type HD, Heavy Duty, Double Throw, 240, 600-V ac, 1200 A and Smaller: UL 98 and NEMA KS 1, horsepower rated, lockable handle with capability to accept three padlocks, and interlocked with cover in closed position.
- E. Accessories:

1. Equipment Ground Kit: Internally mounted and labeled for copper and aluminum ground conductors.
2. Neutral Kit: Internally mounted; insulated, capable of being grounded and bonded; labeled for copper and aluminum neutral conductors.
3. Isolated Ground Kit: Internally mounted; insulated, capable of being grounded and bonded; labeled for copper and aluminum neutral conductors.
4. Auxiliary Contact Kit: Two NO/NC (Form "C") auxiliary contact(s), arranged to activate before switch blades open.
5. Hook-stick Handle: Allows use of a hook-stick to operate the handle.
6. Lugs: Mechanical type, suitable for number, size, and conductor material.
7. Accessory Control Power Voltage: Remote mounted and powered; 120-V ac.

2.03 MOLDED-CASE CIRCUIT BREAKERS

- A. Manufacturers: Subject to compliance with requirements, provide products by one of the following:
 1. Square D.
 2. Cutler-Hammer
 3. GE
 4. Siemens
- B. General Requirements: Comply with UL 489, NEMA AB 1, and NEMA AB 3, with interrupting capacity to comply with available fault currents.
- C. Thermal-Magnetic Circuit Breakers: Inverse time-current element for low-level overloads and instantaneous magnetic trip element for short circuits. Adjustable magnetic trip setting for circuit-breaker frame sizes 250 A and larger.
- D. Adjustable, Instantaneous-Trip Circuit Breakers: Magnetic trip element with front-mounted, field-adjustable trip setting.
- E. Electronic Trip Circuit Breakers: Field-replaceable rating plug, rms sensing, with the following field-adjustable settings:
 1. Instantaneous trip.
 2. Long- and short-time pickup levels.
 3. Long- and short-time time adjustments.
 4. Ground-fault pickup level, time delay, and I^2t response.
- F. Current-Limiting Circuit Breakers: Frame sizes 400 A and smaller, and let-through ratings less than NEMA FU 1, RK-5.
- G. Integrally Fused Circuit Breakers: Thermal-magnetic trip element with integral limiter-style fuse listed for use with circuit breaker and trip activation on fuse opening or on opening of fuse compartment door.
- H. Ground-Fault, Circuit-Interrupter (GFCI) Circuit Breakers: Single- and two-pole configurations with Class A ground-fault protection (6-mA trip).
- I. Ground-Fault, Equipment-Protection (GFEP) Circuit Breakers: With Class B ground-fault protection (30-mA trip).
- J. Features and Accessories:
 1. Standard frame sizes, trip ratings, and number of poles.

2. Lugs: Mechanical type, suitable for number, size, trip ratings, and conductor material.
3. Application Listing: Appropriate for application; Type SWD for switching fluorescent lighting loads; Type HID for feeding fluorescent and high-intensity discharge lighting circuits.
4. Ground-Fault Protection: Comply with UL 1053; integrally mounted, self-powered type with mechanical ground-fault indicator; relay with adjustable pickup and time-delay settings, push-to-test feature, internal memory, and shunt trip unit; and three-phase, zero-sequence current transformer/sensor.
5. Communication Capability: Integral communication module with functions and features compatible with power monitoring and control system, specified in Division 26 Section "Electrical Power Monitoring and Control."
6. Shunt Trip: Trip coil energized from separate circuit, with coil-clearing contact.
7. Under-voltage Trip: Set to operate at 35 to 75 percent of rated voltage without intentional time delay.
8. Auxiliary Contacts: Two SPDT switches with "a" and "b" contacts; "a" contacts mimic circuit-breaker contacts, "b" contacts operate in reverse of circuit-breaker contacts.
9. Key Interlock Kit: Externally mounted to prohibit circuit-breaker operation; key shall be removable only when circuit breaker is in off position.
10. Electrical Operator: Provide remote control for on, off, and reset operations.

2.04 ENCLOSURES

- A. Enclosed Switches and Circuit Breakers: NEMA AB 1, NEMA KS 1, NEMA 250, and UL 50, to comply with environmental conditions at installed location.
 1. Indoor, Dry and Clean Locations: NEMA 250, Type 1.
 2. Outdoor Locations: NEMA 250, Type 3R.
 3. Kitchen and Wash-Down Areas: NEMA 250, Type 4X, stainless steel.
 4. Other Wet or Damp, Indoor Locations: NEMA 250, Type 4-SS.
 5. Indoor Locations Subject to Dust, Falling Dirt, and Dripping Non-corrosive Liquids: NEMA 250, Type 12.
 6. Hazardous Areas Indicated on Drawings: NEMA 250, Type 7.

PART 3 - EXECUTION

3.01 EXAMINATION

- A. Examine elements and surfaces to receive enclosed switches and circuit breakers for compliance with installation tolerances and other conditions affecting performance of the Work.
- B. Proceed with installation only after unsatisfactory conditions have been corrected.

3.02 INSTALLATION

- A. Install individual wall-mounted switches and circuit breakers with tops at uniform height unless otherwise indicated.
- B. Comply with mounting and anchoring requirements specified in Division 26 Section "Vibration and Seismic Controls for Electrical Systems."
- C. Temporary Lifting Provisions: Remove temporary lifting eyes, channels, and brackets and temporary blocking of moving parts from enclosures and components.

- D. Install fuses in fusible devices.
- E. Comply with NECA 1.

3.03 IDENTIFICATION

- A. Comply with requirements in Division 26 Section "Identification for Electrical Systems."
 - 1. Identify field-installed conductors, interconnecting wiring, and components; provide warning signs.
 - 2. Label each enclosure with engraved metal or laminated-plastic nameplate.

3.04 FIELD QUALITY CONTROL

- A. Perform tests and inspections.
 - 1. Manufacturer's Field Service: Engage a factory-authorized service representative to inspect components, assemblies, and equipment installations, including connections, and to assist in testing.
- B. Acceptance Testing Preparation:
 - 1. Test insulation resistance for each enclosed switch and circuit breaker, component, connecting supply, feeder, and control circuit.
 - 2. Test continuity of each circuit.
- C. Tests and Inspections:
 - 1. Perform each visual and mechanical inspection and electrical test stated in NETA Acceptance Testing Specification. Certify compliance with test parameters.
 - 2. Correct malfunctioning units on-site, where possible, and retest to demonstrate compliance; otherwise, replace with new units and retest.
 - 3. Perform the following infrared scan tests and inspections and prepare reports:
 - a. Initial Infrared Scanning: After Substantial Completion, but not more than 60 days after Final Acceptance, perform an infrared scan of each enclosed switch and circuit breaker. Remove front panels so joints and connections are accessible to portable scanner.
 - b. Follow-up Infrared Scanning: Perform an additional follow-up infrared scan of each enclosed switch and circuit breaker 11 months after date of Substantial Completion.
 - c. Instruments and Equipment: Use an infrared scanning device designed to measure temperature or to detect significant deviations from normal values. Provide calibration record for device.
 - 4. Test and adjust controls, remote monitoring, and safeties. Replace damaged and malfunctioning controls and equipment.
- D. Enclosed switches and circuit breakers will be considered defective if they do not pass tests and inspections.
- E. Prepare test and inspection report, including a certified report that identifies enclosed switches and circuit breakers and that describes scanning results. Include notation of deficiencies detected, remedial action taken and observations after remedial action.

3.05 ADJUSTING

- A. Adjust moving parts and operable components to function smoothly, and lubricate as recommended by manufacturer.

END OF SECTION

SECTION 264313 - TRANSIENT-VOLTAGE SUPPRESSION FOR LOW-VOLTAGE ELECTRICAL POWER CIRCUITS

PART 1 - GENERAL

1.01 RELATED DOCUMENTS

- A. Drawings and general provisions of the Contract, including General and Supplementary Conditions and Division 01 Specification Sections, apply to this Section.

1.02 SUMMARY

- A. Section includes field-mounted TVSS for low-voltage (120 to 600 V) power distribution and control equipment.
- B. Related Sections:
 - 1. Division 26 Section "Switchboards" for factory-installed TVSS.
 - 2. Division 26 Section "Panelboards" for factory-installed TVSS.
 - 3. Division 26 Section "Wiring Devices" for devices with integral TVSS.

1.03 DEFINITIONS

- A. ATS: Acceptance Testing Specifications.
- B. SVR: Suppressed voltage rating.
- C. TVSS: Transient voltage surge suppressor(s), both singular and plural; also, transient voltage surge suppression.

1.04 SUBMITTALS

- A. Product Data: For each type of product indicated. Include rated capacities, operating weights, electrical characteristics, furnished specialties, and accessories.
- B. Qualification Data: For qualified testing agency.
- C. Product Certificates: For TVSS devices, from manufacturer.
- D. Field quality-control reports.
- E. Operation and Maintenance Data: For TVSS devices to include in emergency, operation, and maintenance manuals.
- F. Warranties: Sample of special warranties.

1.05 QUALITY ASSURANCE

- A. Testing Agency Qualifications: Member company of NETA or an NRTL.
 - 1. Testing Agency's Field Supervisor: Currently certified by NETA to supervise on-site testing.
- B. Electrical Components, Devices, and Accessories: Listed and labeled as defined in NFPA 70, by a testing agency, and marked for intended location and application.
- C. Comply with IEEE C62.41.2 and test devices according to IEEE C62.45.
- D. Comply with NEMA LS 1.
- E. Comply with UL 1283 and UL 1449.

F. Comply with NFPA 70.

1.06 PROJECT CONDITIONS

- A. Interruption of Existing Electrical Service: Do not interrupt electrical service to facilities occupied by Owner or others unless permitted under the following conditions and then only after arranging to provide temporary electrical service according to requirements indicated:
1. Notify Owner no fewer than four days in advance of proposed electrical service interruptions.
 2. Do not proceed with interruption of electrical service without Owner's written permission.

1.07 COORDINATION

- A. Coordinate location of field-mounted TVSS devices to allow adequate clearances for maintenance.
- B. Coordinate TVSS devices with Division 26 Section "Electrical Power Monitoring and Control."

1.08 WARRANTY

- A. Special Warranty: Manufacturer's standard form in which manufacturer agrees to repair or replace components of surge suppressors that fail in materials or workmanship within specified warranty period.
1. Warranty Period: Five years from date of Substantial Completion.

1.09 EXTRA MATERIALS

- A. Furnish extra materials that match products installed and that are packaged with protective covering for storage and identified with labels describing contents.
1. Replaceable Protection Modules: One of each size and type installed.

PART 2 - PRODUCTS

2.01 SERVICE ENTRANCE SUPPRESSORS

- A. Manufacturers: Subject to compliance with requirements, provide products by one of the following:
1. Square D.
 2. GE.
 3. Cutler-Hammer.
 4. Liebert
 5. Current Technology Inc.; Danaher Power Solutions.
 6. Leviton
- B. Surge Protection Devices:
1. Non-modular.
 2. LED indicator lights for power and protection status.
 3. Audible alarm, with silencing switch, to indicate when protection has failed.
 4. Form-C contacts rated at 5 A and 250-V ac, one normally open and one normally closed, for remote monitoring of protection status. Contacts shall reverse on failure of any surge diversion module or on opening of any current-limiting device. Coordinate with building power monitoring and control system.
- C. Surge Protection Devices:

1. Comply with UL 1449.
 2. Modular design.
 3. Fuses, rated at 200-kA interrupting capacity.
 4. Fabrication using bolted compression lugs for internal wiring.
 5. Integral disconnect switch.
 6. Redundant suppression circuits.
 7. Redundant replaceable modules.
 8. Arrangement with copper bus bars and for bolted connections to phase buses, neutral bus, and ground bus.
 9. Arrangement with wire connections to phase buses, neutral bus, and ground bus.
 10. LED indicator lights for power and protection status.
 11. Audible alarm, with silencing switch, to indicate when protection has failed.
 12. Form-C contacts rated at 5 A and 250-V ac, one normally open and one normally closed, for remote monitoring of protection status. Contacts shall reverse on failure of any surge diversion module or on opening of any current-limiting device. Coordinate with building power monitoring and control system.
 13. Six-digit transient-event counter set to totalize transient surges.
- D. Peak Single-Impulse Surge Current Rating: 320 kA per mode/640 kA per phase.
- E. Minimum single impulse current ratings, using 8-by-20-mic.sec waveform described in IEEE C62.41.2
1. Line to Neutral: 70,000
 2. Line to Ground: 70,000
 3. Neutral to Ground: 50,000A.
- F. Protection modes and UL 1449 SVR for grounded wye circuits with 480Y/277 V and 208Y/120 V, 3-phase, 4-wire circuits shall be as follows:
1. Line to Neutral: 800 V for 480Y/277 V, 400 V for 208Y/120 V.
 2. Line to Ground: 800 V for 480Y/277 V, 400 V for 208Y/120 V.
 3. Neutral to Ground: 800 V for 480Y/277 V, 400 V for 208Y/120 V.

2.02 PANELBOARD SUPPRESSORS

- A. Manufacturers: Subject to compliance with requirements, provide products by one of the following:
1. Square D.
 2. GE.
 3. Eaton.
 4. Advanced Protection Technologies Inc. (APT).
 5. Current Technology Inc.; Danaher Power Solutions.
 6. Dehn Inc.
- B. Surge Protection Devices:
1. Non-modular.
 2. LED indicator lights for power and protection status.
 3. Audible alarm, with silencing switch, to indicate when protection has failed.

4. Form-C contacts rated at 5 A and 250-V ac, one normally open and one normally closed, for remote monitoring of protection status. Contacts shall reverse on failure of any surge diversion module or on opening of any current-limiting device. Coordinate with building power monitoring and control system.
- C. Surge Protection Devices:
1. Comply with UL 1449.
 2. Modular design.
 3. Short-circuit current rating complying with UL 1449, and matching or exceeding the panelboard short-circuit rating and redundant suppression circuits; with individually fused metal-oxide varistors.
 4. Fuses, rated at 200-kA interrupting capacity.
 5. Fabrication using bolted compression lugs for internal wiring.
 6. Integral disconnect switch.
 7. Redundant suppression circuits.
 8. Redundant replaceable modules.
 9. Arrangement with wire connections to phase buses, neutral bus, and ground bus.
 10. LED indicator lights for power and protection status.
 11. Audible alarm, with silencing switch, to indicate when protection has failed.
 12. Form-C contacts rated at 5 A and 250-V ac, one normally open and one normally closed, for remote monitoring of protection status. Contacts shall reverse on failure of any surge diversion module or on opening of any current-limiting device. Coordinate with building power monitoring and control system.
 13. Six-digit transient-event counter set to totalize transient surges.
- D. Peak Single-Impulse Surge Current Rating: 160 kA per mode/320 kA per phase.
- E. Minimum single impulse current ratings, using 8-by-20-mic.sec waveform described in IEEE C62.41.2:
1. Line to Neutral: 70,000 A.
 2. Line to Ground: 70,000 A.
 3. Neutral to Ground: 50,000 A.
- F. Protection modes and UL 1449 SVR for grounded wye circuits with 480Y/277 V, 208Y/120 V, 3-phase, 4-wire circuits shall be as follows:
1. Line to Neutral: 800 V for 480Y/277 V, 400 V for 208Y/120 V.
 2. Line to Ground: 800 V for 480Y/277 V, 400 V for 208Y/120 V.
 3. Neutral to Ground: 800 V for 480Y/277 V, 400 V for 208Y/120 V.

2.03 ENCLOSURES

- A. Indoor Enclosures: NEMA 250 Type 1.
- B. Outdoor Enclosures: NEMA 250 Type 3R.

PART 3 - EXECUTION

3.01 INSTALLATION

- A. Install TVSS devices at service entrance on load side, with ground lead bonded to service entrance ground.

- B. Install TVSS devices for panelboards and auxiliary panels with conductors or buses between suppressor and points of attachment as short and straight as possible. Do not exceed manufacturer's recommended lead length. Do not bond neutral and ground.
 - 1. Provide multiple, 30, 60 or 100. A circuit breaker as applicable as a dedicated disconnecting means for TVSS unless otherwise indicated.

3.02 FIELD QUALITY CONTROL

- A. Manufacturer's Field Service: Engage a factory-authorized service representative to inspect, test, and adjust components, assemblies, and equipment installations, including connections.
 - 1. Verify that electrical wiring installation complies with manufacturer's written installation requirements.
- B. Tests and Inspections:
 - 1. Perform each visual and mechanical inspection and electrical test stated in NETA ATS, "Surge Arresters, Low-Voltage Surge Protection Devices" Section. Certify compliance with test parameters.
 - 2. After installing TVSS devices but before electrical circuitry has been energized, test for compliance with requirements.
 - 3. Complete startup checks according to manufacturer's written instructions.
- C. TVSS device will be considered defective if it does not pass tests and inspections.
- D. Prepare test and inspection reports.

3.03 STARTUP SERVICE

- A. Do not energize or connect service entrance equipment, panelboards, control terminals or data terminals to their sources until TVSS devices are installed and connected.
- B. Do not perform insulation resistance tests of the distribution wiring equipment with the TVSS installed. Disconnect before conducting insulation resistance tests, and reconnect immediately after the testing is over.

3.04 DEMONSTRATION

- A. Engage a factory-authorized service representative to train. Owner's maintenance personnel to maintain TVSS devices.

END OF SECTION

SECTION 265100 - INTERIOR LIGHTING

PART 1 - GENERAL

1.01 RELATED DOCUMENTS

- A. Drawings and general provisions of the Contract, including General and Supplementary Conditions and Division 01 Specification Sections, apply to this Section.

1.02 SUMMARY

- A. This Section includes the following:
 1. Interior lighting fixtures, lamps, and ballasts.
 2. Emergency lighting units.
 3. Exit signs lighted
 4. Lighting fixture supports.
 5. Retrofit kits for fluorescent lighting fixtures.
- B. Related Sections include the following:
 1. Division 26 Section "Lighting Control Devices" for automatic control of lighting, including time switches, photoelectric relays, occupancy sensors, and multiple lighting relays and contactors.
 2. Division 26 Section "Wiring Devices" for manual wall-box dimmers for incandescent lamps.
 3. Division 26 Section "Theatrical Lighting" for theatrical lighting fixtures and their controls.

1.03 DEFINITIONS

- A. BF: Ballast factor.
- B. CRI: Color-rendering index.
- C. CU: Coefficient of utilization.
- D. HID: High-intensity discharge.
- E. LER: Luminaire efficacy rating.
- F. Luminaire: Complete lighting fixture, including ballast housing if provided.
- G. RCR: Room cavity ratio.

1.04 SUBMITTALS

- A. Product Data: For each type of lighting fixture, arranged in order of fixture designation. Include data on features, accessories, finishes, and the following:
 1. Physical description of lighting fixture including dimensions.
 2. Emergency lighting units including battery and charger.
 3. Ballast.
 4. Energy-efficiency data.
 5. Air and Thermal Performance Data: For air-handling lighting fixtures. Furnish data required in "Submittals" Article in Division 23 Section "Diffusers, Registers, and Grilles."
 6. Sound Performance Data: For air-handling lighting fixtures. Indicate sound power level and sound transmission class in test reports certified according to standards specified in Di-

vision 23 Section "Diffusers, Registers, and Grilles."

7. Life, output, and energy-efficiency data for lamps.
8. Photometric data, in IESNA format, based on laboratory tests of each lighting fixture type, outfitted with lamps, ballasts, and accessories identical to those indicated for the lighting fixture as applied in this Project.
 - a. For indicated fixtures, photometric data shall be certified by a qualified independent testing agency. Photometric data for remaining fixtures shall be certified by the manufacturer.
 - b. Photometric data shall be certified by a manufacturer's laboratory with a current accreditation under the National Voluntary Laboratory Accreditation Program (NVLAP) for Energy Efficient Lighting Products.
- B. Shop Drawings: Show details of nonstandard or custom lighting fixtures. Indicate dimensions, weights, methods of field assembly, components, features, and accessories.
 1. Wiring Diagrams: Power and control wiring.
- C. Samples for Verification: Interior lighting fixtures designated for sample submission in Interior Lighting Fixture Schedule. Each sample shall include the following:
 1. Lamps: Specified units installed.
 2. Accessories: Cords and plugs.
- D. Product Certificates: For each type of ballast for bi-level and dimmer-controlled fixtures, signed by product manufacturer.
- E. Qualification Data: For agencies providing photometric data for lighting fixtures.
- F. Field quality-control test reports.
- G. Operation and Maintenance Data: For lighting equipment and fixtures to include in emergency, operation, and maintenance manuals.
- H. Warranties: Special warranties specified in this Section.

1.05 QUALITY ASSURANCE

- A. Luminaire Photometric Data Testing Laboratory Qualifications: Provided by manufacturers' laboratories that are accredited under the National Volunteer Laboratory Accreditation Program for Energy Efficient Lighting Products.
- B. Luminaire Photometric Data Testing Laboratory Qualifications: Provided by an independent agency, with the experience and capability to conduct the testing indicated, that is an NRTL as defined by OSHA in 29 CFR 1910.7.
- C. Electrical Components, Devices, and Accessories: Listed and labeled as defined in NFPA 70, Article 100, by a testing agency acceptable to authorities having jurisdiction, and marked for intended use.
- D. Comply with NFPA 70.
- E. FMG Compliance: Lighting fixtures for hazardous locations shall be listed and labeled for indicated class and division of hazard by FMG.
- F. Mockups: Provide interior lighting fixtures for room or module mock-ups, complete with power and control connections.
 1. Obtain Architect's approval of fixtures for mockups before starting installations.
 2. Maintain mockups during construction in an undisturbed condition as a standard for judging the completed Work.

3. Approved fixtures in mockups may become part of the completed Work if undisturbed at time of Substantial Completion.

1.06 COORDINATION

- A. Coordinate layout and installation of lighting fixtures and suspension system with other construction that penetrates ceilings or is supported by them, including HVAC equipment, fire-suppression system, and partition assemblies.

1.07 WARRANTY

- A. Special Warranty for Emergency Lighting Batteries: Manufacturer's standard form in which manufacturer of battery-powered emergency lighting unit agrees to repair or replace components of rechargeable batteries that fail in materials or workmanship within specified warranty period.
 1. Warranty Period for Emergency Lighting Unit Batteries: 5 years from date of Substantial Completion. Full warranty shall apply for first year, and prorated warranty for the remaining nine years.
 2. Warranty Period for Emergency Fluorescent Ballast Batteries: 5 years from date of Substantial Completion. Full warranty shall apply for first year, and prorated warranty for the remaining six years.
- B. Special Warranty for Ballasts: Manufacturer's standard form in which ballast manufacturer agrees to repair or replace ballasts that fail in materials or workmanship within specified warranty period.
 1. Warranty Period for Electronic Ballasts: Five years from date of Substantial Completion.
 2. Warranty Period for Electromagnetic Ballasts: Three years from date of Substantial Completion.
- C. Special Warranty for T5 and T8 Fluorescent Lamps: Manufacturer's standard form, made out to Owner and signed by lamp manufacturer agreeing to replace lamps that fail in materials or workmanship, f.o.b. the nearest shipping point to Project site, within specified warranty period indicated below.
 1. Warranty Period: Two year(s) from date of Substantial Completion.

1.08 EXTRA MATERIALS

- A. Furnish extra materials described below that match products installed and that are packaged with protective covering for storage and identified with labels describing contents.
 1. Lamps: 10 for every 100 of each type and rating installed. Furnish at least one of each type.
 2. Plastic Diffusers and Lenses: 1 for every 100 of each type and rating installed. Furnish at least one of each type.
 3. Battery and Charger Data: One for each emergency lighting unit.
 4. Ballasts: 1 for every 100 of each type and rating installed. Furnish at least one of each type.
 5. Globes and Guards: 1 for every 20 of each type and rating installed. Furnish at least one of each type.

PART 2 - PRODUCTS

2.01 MANUFACTURERS

- A. In other Part 2 articles where titles below introduce lists, the following requirements apply to

product selection:

- B. In Interior Lighting Fixture Schedule where titles below are column or row headings that introduce lists, the following requirements apply to product selection:
 - 1. Available Manufacturers: Subject to compliance with requirements, manufacturers offering products that may be incorporated into the Work include, but are not limited to, manufacturers specified.
- C. Luminaires, Acceptable Manufacturers:
 - 1. Cooper
 - 2. Genlyte
 - 3. General Electric
 - 4. Hubbell
 - 5. Kenall
 - 6. Lithonia
- D. Lamps, Acceptable Manufacturers:
 - 1. General Electric
 - 2. Osram Sylvania
 - 3. North American Phillips
- E. Ballasts, Acceptable Manufacturers:
 - 1. Advance Transformer Co.
 - 2. Universal Lighting Technology
 - 3. Osram
 - 4. Sylvania

2.02 LIGHTING FIXTURES AND COMPONENTS, GENERAL REQUIREMENTS

- A. Recessed Fixtures: Comply with NEMA LE 4 for ceiling compatibility for recessed fixtures.
- B. Incandescent Fixtures: Comply with UL 1598. Where LER is specified, test according to NEMA LE 5A.
- C. Fluorescent Fixtures: Comply with UL 1598. Where LER is specified, test according to NEMA LE 5 and NEMA LE 5A as applicable.
- D. HID Fixtures: Comply with UL 1598. Where LER is specified, test according to NEMA LE 5B.
- E. Metal Parts: Free of burrs and sharp corners and edges.
- F. Sheet Metal Components: Steel, unless otherwise indicated. Form and support to prevent warping and sagging.
- G. Doors, Frames, and Other Internal Access: Smooth operating, free of light leakage under operating conditions, and designed to permit re-lamping without use of tools. Designed to prevent doors, frames, lenses, diffusers, and other components from falling accidentally during re-lamping and when secured in operating position.
- H. Reflecting surfaces shall have minimum reflectance as follows, unless otherwise indicated:
 - 1. White Surfaces: 85 percent.
 - 2. Specular Surfaces: 83 percent.
 - 3. Diffusing Specular Surfaces: 75 percent.

4. Laminated Silver Metalized Film: 90 percent.
- I. Plastic Diffusers, Covers, and Globes:
 1. Acrylic Lighting Diffusers: 100 percent virgin acrylic plastic. High resistance to yellowing and other changes due to aging, exposure to heat, and UV radiation.
 - a. Lens Thickness: At least 0.125 inch minimum unless different thickness is indicated.
 - b. UV stabilized.
 2. Glass: Annealed crystal glass, unless otherwise indicated.
- J. Electromagnetic-Interference Filters: Factory installed to suppress conducted electromagnetic-interference as required by MIL-STD-461E. Fabricate lighting fixtures, indicated to require a filter, with one filter per ballast.
- K. Air-Handling Fluorescent Fixtures: For use with plenum ceiling for air return and heat extraction and for attaching an air-diffuser-boot assembly specified in Division 23 Section "Diffusers, Registers, and Grilles."
 1. Air Supply Units: Slots in one or both side trims join with air-diffuser-boot assemblies.
 2. Heat Removal Units: Air path leads through lamp cavity.
 3. Combination Heat Removal and Air Supply Unit: Heat is removed through lamp cavity at both ends of the fixture door with air supply same as for air supply units.
 4. Dampers: Operable from outside fixture for control of return-air volume.
 5. Static Fixture: Air supply slots are blanked off, and fixture appearance matches active units.

2.03 BALLASTS FOR LINEAR FLUORESCENT LAMPS

- A. Electronic Ballasts: Comply with ANSI C82.11; instant-start type, unless otherwise indicated, and designed for type and quantity of lamps served. Ballasts shall be designed for full light output unless dimmer or bi-level control is indicated.
 1. Sound Rating: A.
 2. See Evaluations for discussion of harmonic considerations.
 3. Total Harmonic Distortion Rating: Less than 10 percent.
 4. Transient Voltage Protection: IEEE C62.41, Category A or better.
 5. Operating Frequency: 20 kHz or higher.
 6. Lamp Current Crest Factor: 1.7 or less.
 7. BF: 0.85 or higher.
 8. Power Factor: 0.95 or higher.
 9. Parallel Lamp Circuits: Multiple lamp ballasts shall comply with ANSI C 82.11 and shall be connected to maintain full light output on surviving lamps if one or more lamps fail.
- B. Electronic Programmed-Start Ballasts for T5 Lamps: Comply with ANSI C82.11 and the following:
 1. Lamp end-of-life detection and shutdown circuit for T5 diameter lamps.
 2. Automatic lamp starting after lamp replacement.
 3. Sound Rating: A.
 4. Total Harmonic Distortion Rating: Less than 20 percent.
 5. Transient Voltage Protection: IEEE C62.41, Category A or better.
 6. Operating Frequency: 20 kHz or higher.

7. Lamp Current Crest Factor: 1.7 or less.
 8. BF: 0.95 or higher, unless otherwise indicated.
 9. Power Factor: 0.95 or higher.
- C. Electromagnetic Ballasts: Comply with ANSI C82.1; energy saving, high-power factor, Class P, and having automatic-reset thermal protection.
1. Ballast Manufacturer Certification: Indicated by label.
- D. Ballasts for Low-Temperature Environments:
1. Temperatures 0 Deg F and Higher: Electronic or electromagnetic type rated for 0 deg F starting and operating temperature with indicated lamp types.
- E. Ballasts for Low Electromagnetic-Interference Environments: Comply with 47 CFR, Chapter 1, Part 18, Subpart C, for limitations on electromagnetic and radio-frequency interference for consumer equipment.
- F. Ballasts for Dimmer-Controlled Lighting Fixtures: Electronic type.
1. Dimming Range: 100 to 5 percent of rated lamp lumens.
 2. Ballast Input Watts: Can be reduced to 20 percent of normal.
 3. Compatibility: Certified by manufacturer for use with specific dimming control system and lamp type indicated.
- G. Ballasts for Bi-Level Controlled Lighting Fixtures: Electronic type.
1. Operating Modes: Ballast circuit and leads provide for remote control of the light output of the associated lamp between high- and low-level and off.
 - a. High-Level Operation: 100 percent of rated lamp lumens.
 - b. Low-Level Operation: 30 percent of rated lamp lumens.
 2. Ballast shall provide equal current to each lamp in each operating mode.
 3. Compatibility: Certified by manufacturer for use with specific bi-level control system and lamp type indicated.

2.04 BALLASTS FOR COMPACT FLUORESCENT LAMPS

- A. Description: Electronic programmed rapid-start type, complying with ANSI C 82.11, designed for type and quantity of lamps indicated. Ballast shall be designed for full light output unless dimmer or bi-level control is indicated:
1. Lamp end-of-life detection and shutdown circuit.
 2. Automatic lamp starting after lamp replacement.
 3. Sound Rating: A.
 4. Total Harmonic Distortion Rating: Less than 20 percent.
 5. Transient Voltage Protection: IEEE C62.41, Category A or better.
 6. Operating Frequency: 20 kHz or higher.
 7. Lamp Current Crest Factor: 1.7 or less.
 8. BF: 0.95 or higher, unless otherwise indicated.
 9. Power Factor: 0.95 or higher.
 10. Interference: Comply with 47 CFR, Chapter 1, Part 18, Subpart C, for limitations on electromagnetic and radio-frequency interference for non-consumer equipment.
 11. Ballast Case Temperature: 75 deg C, maximum.
- B. Ballasts for Dimmer-Controlled Lighting Fixtures: Electronic type.

1. Dimming Range: 100 to 5 percent of rated lamp lumens.
2. Ballast Input Watts: Can be reduced to 20 percent of normal.
3. Compatibility: Certified by manufacturer for use with specific dimming control system and lamp type indicated.

2.05 EMERGENCY FLUORESCENT POWER UNIT

- A. Internal Type: Self-contained, modular, battery-inverter unit, factory mounted within lighting fixture body and compatible with ballast. Comply with UL 924.
1. Emergency Connection: Operate 1 fluorescent lamp(s) continuously at an output of 1100 lumens each. Connect un-switched circuit to battery-inverter unit and switched circuit to fixture ballast.
 2. Night-Light Connection: Operate one fluorescent lamp continuously.
 3. Test Push Button and Indicator Light: Visible and accessible without opening fixture or entering ceiling space.
 - a. Push Button: Push-to-test type, in unit housing, simulates loss of normal power and demonstrates unit operability.
 - b. Indicator Light: LED indicates normal power on. Normal glow indicates trickle charge; bright glow indicates charging at end of discharge cycle.
 4. Battery: Sealed, maintenance-free, nickel-cadmium type.
 5. Charger: Fully automatic, solid-state, constant-current type with sealed power transfer relay.
 6. Remote Test: Switch in hand-held remote device aimed in direction of tested unit initiates coded infrared signal. Signal reception by factory-installed infrared receiver in tested unit triggers simulation of loss of its normal power supply, providing visual confirmation of either proper or failed emergency response.
 7. Integral Self-Test: Factory-installed electronic device automatically initiates code-required test of unit emergency operation at required intervals. Test failure is annunciated by an integral audible alarm and flashing red LED.

2.06 BALLASTS FOR HID LAMPS

- A. Electromagnetic Ballast for Metal-Halide Lamps: Comply with ANSI C82.4 and UL 1029. Include the following features, unless otherwise indicated:
1. Ballast Circuit: Constant-wattage autotransformer or regulating high-power-factor type.
 2. Minimum Starting Temperature: Minus 22 deg F for single-lamp ballasts.
 3. Normal Ambient Operating Temperature: 104 deg F.
 4. Open-circuit operation that will not reduce average life.
 5. Low-Noise Ballasts: Manufacturers' standard epoxy-encapsulated models designed to minimize audible fixture noise.
- B. Electronic Ballast for Metal-Halide Lamps: Include the following features unless otherwise indicated:
1. Lamp end-of-life detection and shutdown circuit.
 2. Sound Rating: A.
 3. Total Harmonic Distortion Rating: Less than 15 percent.
 4. Transient Voltage Protection: IEEE C62.41, Category A or better.
 5. Lamp Current Crest Factor: 1.5 or less.

6. Power Factor: .90 or higher.
 7. Interference: Comply with 47 CFR, Chapter 1, Part 18, Subpart C, for limitations on electromagnetic and radio-frequency interference for non-consumer equipment.
 8. Protection: Class P thermal cutoff.
 9. Retain subparagraph and associated subparagraphs below for bi-level ballasts.
 10. Bi-Level Dimming Ballast: Ballast circuit and leads provide for remote control of the light output of the associated fixture between high- and low-level and off.
 - a. High-Level Operation: 100 percent of rated lamp lumens.
 - b. Low-Level Operation: 35 percent of rated lamp lumens.
 - c. Compatibility: Certified by ballast manufacturer for use with specific bi-level control system and lamp type indicated. Certified by lamp manufacturer that ballast operating modes are free from negative effect on lamp life and color-rendering capability.
 11. Continuous Dimming Ballast: Dimming range shall be from 100 to 35 percent of rated lamp lumens without flicker.
 - a. Ballast Input Watts: Reduced to a maximum of 50 percent of normal at lowest dimming setting.
 - b. Compatibility: Certified by manufacturer for use with specific dimming control system and lamp type indicated. Certified by lamp manufacturer that ballast operating modes are free from negative effect on lamp life and color-rendering capability.
- C. Auxiliary Instant-On Quartz System: Factory-installed feature automatically switches quartz lamp on when fixture is initially energized and when power outages occur. System automatically turns quartz lamp off when HID lamp reaches approximately 60 percent light output.
- D. High-Pressure Sodium Ballasts: Electromagnetic type, with solid-state igniter/starter. Igniter-starter shall have an average life in pulsing mode of 10,000 hours at an igniter/starter-case temperature of 90 deg C.
1. Instant Re-strike Device: Integral with ballast, or solid-state potted module, factory installed within fixture and compatible with lamps, ballasts, and mogul sockets up to 150 W.
 - a. Re-strike Range: 105- to 130-V ac.
 - b. Maximum Voltage: 250-V peak or 150-V ac RMS.
 2. Minimum Starting Temperature: Minus 40 deg F.
 3. Open-circuit operation shall not reduce average lamp life.

2.07 EXIT SIGNS LIGHTED

- A. Description: Comply with UL 924; for sign colors, visibility, luminance, and lettering size, comply with authorities having jurisdiction.
- B. Internally Lighted Signs:
 1. Lamps for AC Operation: Fluorescent, 2 for each fixture, 20,000 hours of rated lamp life.
 2. Lamps for AC Operation: LEDs, 70,000 hours minimum rated lamp life.
 3. Self-Powered Exit Signs (Battery Type): Integral automatic charger in a self-contained power pack.
 - a. Battery: Sealed, maintenance-free, nickel-cadmium type.
 - b. Charger: Fully automatic, solid-state type with sealed transfer relay.
 - c. Operation: Relay automatically energizes lamp from battery when circuit voltage drops to 80 percent of nominal voltage or below. When normal voltage is restored, relay disconnects lamps from battery, and battery is automatically recharged and floated.

- on charger.
- d. Test Push Button: Push-to-test type, in unit housing, simulates loss of normal power and demonstrates unit operability.
 - e. LED Indicator Light: Indicates normal power on. Normal glow indicates trickle charge; bright glow indicates charging at end of discharge cycle.
 - f. Remote Test: Switch in hand-held remote device aimed in direction of tested unit initiates coded infrared signal. Signal reception by factory-installed infrared receiver in tested unit triggers simulation of loss of its normal power supply, providing visual confirmation of either proper or failed emergency response.
 - g. Integral Self-Test: Factory-installed electronic device automatically initiates code-required test of unit emergency operation at required intervals. Test failure is annunciated by an integral audible alarm and flashing red LED.
4. Master/Remote Sign Configurations:
- a. Master Unit: Comply with requirements above for self-powered exit signs, and provide additional capacity in LED power supply for power connection to remote unit.
 - b. Remote Unit: Comply with requirements above for self-powered exit signs, except omit power supply, battery and test features. Arrange to receive full power requirements from master unit. Connect for testing concurrently with master unit as a unified system.

2.08 EMERGENCY LIGHTING UNITS

- A. Description: Self-contained units complying with UL 924.
- 1. Battery: Sealed, maintenance-free, lead-acid type.
 - 2. Charger: Fully automatic, solid-state type with sealed transfer relay.
 - 3. Operation: Relay automatically turns lamp on when power supply circuit voltage drops to 80 percent of nominal voltage or below. Lamp automatically disconnects from battery when voltage approaches deep-discharge level. When normal voltage is restored, relay disconnects lamps from battery, and battery is automatically recharged and floated on charger.
 - 4. Test Push Button: Push-to-test type, in unit housing, simulates loss of normal power and demonstrates unit operability.
 - 5. LED Indicator Light: Indicates normal power on. Normal glow indicates trickle charge; bright glow indicates charging at end of discharge cycle.
 - 6. Wire Guard: Heavy-chrome-plated wire guard protects lamp heads or fixtures.
 - 7. Integral Time-Delay Relay: Holds unit on for fixed interval of 5 minutes when power is restored after an outage.
 - 8. Remote Test: Switch in hand-held remote device aimed in direction of tested unit initiates coded infrared signal. Signal reception by factory-installed infrared receiver in tested unit triggers simulation of loss of its normal power supply, providing visual confirmation of either proper or failed emergency response.
 - 9. Integral Self-Test: Factory-installed electronic device automatically initiates code-required test of unit emergency operation at required intervals. Test failure is annunciated by an integral audible alarm and flashing red LED.

2.09 FLUORESCENT LAMPS

- A. Low-Mercury Lamps: Comply with EPA's toxicity characteristic leaching procedure test; shall yield less than 0.2 mg of mercury per liter when tested according to NEMA LL 1.
- B. T8 rapid-start lamps, rated 32 W maximum, nominal length of 48 inches, 2800 initial lumens

(minimum), CRI 75 (minimum), color temperature 3500 K, and average rated life 20,000 hours, unless otherwise indicated.

- C. T8 rapid-start lamps, rated 17 W maximum, nominal length of 24 inches, 1300 initial lumens (minimum), CRI 75 (minimum), color temperature 3500 K, and average rated life of 20,000 hours, unless otherwise indicated.
- D. T5 rapid-start low-mercury lamps, rated 28 W maximum, nominal length of 45.2 inches, 2900 initial lumens (minimum), CRI 85 (minimum), color temperature 3000 K, and average rated life of 20,000 hours, unless otherwise indicated.
- E. T5HO rapid-start, high-output lamps, rated 54 W maximum, nominal length of 45.2 inches, 5000 initial lumens (minimum), CRI 85 (minimum), color temperature 4100 K, and average rated life of 20,000 hours, unless otherwise indicated.
- F. Compact Fluorescent Lamps: 4-Pin, CRI 80 (minimum), color temperature 3500 K, average rated life of 10,000 hours at 3 hours operation per start, unless otherwise indicated.
 - 1. 13 W: T4, double or triple tube, rated 900 initial lumens (minimum).
 - 2. 18 W: T4, double or triple tube, rated 1200 initial lumens (minimum).
 - 3. 26 W: T4, double or triple tube, rated 1800 initial lumens (minimum).
 - 4. 32 W: T4, triple tube, rated 2400 initial lumens (minimum).
 - 5. 42 W: T4, triple tube, rated 3200 initial lumens (minimum).
 - 6. 55 W: T4, triple tube, rated 4300 initial lumens (minimum).

2.10 HID LAMPS

- A. High-Pressure Sodium Lamps: ANSI C78.42, CRI 21 (minimum), color temperature 1900 K, and average rated life of 24,000 hours, minimum.
 - 1. Dual-Arc Tube Lamps: Arranged so only one of two arc tubes is lighted at one time and, when power is restored after an outage, the cooler arc tube, with lower internal pressure, lights instantly, providing an immediate 8 to 15 percent of normal light output.
- B. Metal-Halide Lamps: ANSI C78.1372, with a minimum CRI 65, and color temperature 4000 K.
- C. Pulse-Start, Metal-Halide Lamps: Minimum CRI 65, and color temperature 4000K.
start Ceramic, Pulse-Start, Metal-Halide Lamps: Minimum CRI 80, and color temperature 4000K.

2.11 LIGHTING FIXTURE SUPPORT COMPONENTS

- A. Comply with Division 26 Section "Hangers and Supports for Electrical Systems" for channel- and angle-iron supports and nonmetallic channel and angle supports.
- B. Single-Stem Hangers: 1/2-inch steel tubing with swivel ball fittings and ceiling canopy. Finish same as fixture.
- C. Twin-Stem Hangers: Two, 1/2-inch steel tubes with single canopy designed to mount a single fixture. Finish same as fixture.
- D. Wires: ASTM A 641/A 641M, Class 3, soft temper, zinc-coated steel, 12 gage.
- E. Wires for Humid Spaces: ASTM A 580/A 580M, Composition 302 or 304, annealed stainless steel, 12 gage.
- F. Rod Hangers: 3/16-inch minimum diameter, cadmium-plated, threaded steel rod.
- G. Hook Hangers: Integrated assembly matched to fixture and line voltage and equipped with

threaded attachment, cord, and locking-type plug.

PART 3 - EXECUTION

3.01 INSTALLATION

- A. Lighting fixtures: Set level, plumb, and square with ceilings and walls. Install lamps in each fixture.
- B. Support for Lighting Fixtures in or on Grid-Type Suspended Ceilings: Use grid as a support element.
 - 1. Install a minimum of four ceiling support system rods or wires for each fixture. Locate not more than 6 inches from lighting fixture corners.
 - 2. Support Clips: Fasten to lighting fixtures and to ceiling grid members at or near each fixture corner with clips that are UL listed for the application.
 - 3. Fixtures of Sizes Less Than Ceiling Grid: Install as indicated on reflected ceiling plans or center in acoustical panel, and support fixtures independently with at least two 3/4-inch metal channels spanning and secured to ceiling tees.
 - 4. Install at least one independent support rod or wire from structure to a tab on lighting fixture. Wire or rod shall have breaking strength of the weight of fixture at a safety factor of 3.
- C. Suspended Lighting Fixture Support:
 - 1. Pendants and Rods: Where longer than 48 inches, brace to limit swinging.
 - 2. Stem-Mounted, Single-Unit Fixtures: Suspend with twin-stem hangers.
 - 3. Continuous Rows: Use tubing or stem for wiring at one point and tubing or rod for suspension for each unit length of fixture chassis, including one at each end.
- D. Air-Handling Lighting Fixtures: Install with dampers closed and ready for adjustment.
- E. Adjust aim-able lighting fixtures to provide required light intensities.
- F. Connect wiring according to Division 26 Section "Low-Voltage Electrical Power Conductors and Cables."

3.02 FIELD QUALITY CONTROL

- A. Test for Emergency Lighting: Interrupt power supply to demonstrate proper operation. Verify transfer from normal power to battery and retransfer to normal.
- B. Prepare a written report of tests, inspections, observations, and verifications indicating and interpreting results. If adjustments are made to lighting system, retest to demonstrate compliance with standards.

END OF SECTION

SECTION 269500 - FIELD ELECTRICAL TESTING

PART 1 - GENERAL

1.01 RELATED DOCUMENTS

- A. Requirements of Division 26 "COMMON WORK RESULTS FOR ELECTRICAL" apply to this Section.

1.02 SECTION INCLUDES

- A. Testing by Installing Contractor
- B. Testing by Independent Testing Contractor

1.03 SUBMITTALS: Submit the following in accordance with Section 260500.

- A. Contractor shall submit experience of testing firm and individuals who will be performing and evaluating tests before any tests are done.
- B. Contractor shall submit in writing at least 24 hours in advance notification of the occurrence of any test described in this section.
- C. Contractor shall record all test data and submit three (3) copies for review. In addition to the test data, each record shall include; date of test, ambient temperature, climate conditions, instruments used, names of test personnel and witnesses and identification of items tested.
- D. The testing firm shall maintain a written record of all tests and, upon completion of project, shall assemble and certify a final test report.

1.04 QUALITY ASSURANCE: Comply with the following.

- A. All tests shall be done in accordance with all applicable codes and standards.
- B. Qualifications of Testing Firm:
 - 1. The testing firm shall be an independent testing organization which can function as an unbiased testing authority, professionally independent of the manufacturers, suppliers, and installers of equipment or systems evaluated by the testing firm.
 - 2. The testing firm shall be regularly engaged in the testing of electrical equipment devices, installations, and systems.
 - 3. The testing firm shall meet OSHA criteria for accreditation of testing laboratories, Title 29, or be a Full Member company of the International Electrical Testing Association (IETA).
 - 4. The testing firm shall utilize engineers and technicians who are regularly employed by the firm for testing services.

PART 2 - PRODUCT (Not Used)

PART 3 - EXECUTION

3.01 DIVISION OF RESPONSIBILITY

- A. All tests indicate in this specification section shall be done by the testing firm except the installing contractor shall be responsible for the following:
 - 1. The contractor shall perform routine insulation-resistance, continuity, and rotation tests for all distribution and utilization equipment prior to and in addition to tests performed by the testing

firm specified herein.

2. 120 Volt General Purpose Receptacles: All 120 volt general purpose receptacles shall be tested for correct connection using a Hubbell Catalog #5200 or equal receptacle tester.
 3. 120 Volt Ground Fault Circuit, Interrupter (GFCI) Receptacles: All 120 volt GFCI receptacles shall be tested for correct connection and rating using Hubbell Catalog #GFT-2G with a range of 2 to 7 milliamps.
 4. Enclosed (Disconnect) Switches: Subsequently to completion of installation of electrical disconnect switches, energize circuits and demonstrate capability and compliance with requirements. Except as otherwise indicated, do not test switches by operating them under load. However, demonstrate switch operation through six opening/closing cycles with circuit unloaded. Open each switch enclosure for inspection of interior, mechanical and electrical connections, fuse installation, and for verification of type and rating of fuses installed. Correct deficiencies then retest to demonstrate compliance. Remove and replace defective units with new units and retest.
 5. Light Switching: Verify proper connection and operation of switches for lighting fixtures.
 6. Lighting Contactors: Demonstrate proper operation of lighting contactors for all items indicated in Division 16.
 7. Balancing Loads: After Substantial Completion, but not more than two months after Final Acceptance, conduct load-balancing measurements on panelboards and circuit changes as follows:
 - a. Perform measurements during period of normal working load as advised by the Owner.
 - b. Perform load-balancing circuit changes outside the normal occupancy/working schedule of the facility. Make special arrangements with Owner to avoid disrupting critical 24-hour services such as fax machines and on-line data processing, computing, transmitting, and receiving equipment.
 - c. Recheck loads after circuit changes during normal load period. Record all load readings before and after changes and submit test records.
 - d. Tolerance: Difference between phase loads exceeding 20 percent at any one panelboard is not acceptable. Rebalance and recheck as required to meet this minimum requirement.
- B. The Contractor shall supply a suitable and stable source of electrical power to each test site. The testing firm shall specify the specific power requirements.
- C. The Contractor shall notify the testing firm when equipment becomes available for acceptance tests. Work shall be coordinated to expedite project scheduling.
- D. Any system, material, or workmanship which is found defective on the basis of acceptance tests shall be reported to the Owner/Engineer's representative replaced or repaired by the Contractor at no cost to the Owner, and retested.
- E. An electrical system will not be accepted until tested in its entirety and results reported to the Owner.
- 3.02 TESTING FIRM;** The testing firm shall test the following equipment as indicated in each section:
- A. 600V Wire and Cables
 - B. Grounding and Bonding.
 - C. Dry Type Transformers.
 - D. Enclosed Motor Controllers

E. Motor Control Center

3.03 INFRARED SCANNING

- A. Provide scanning for Switchboards, Transformers, MCC's, Panelboards, Generator connection points, and Transfer Switches.
- B. After Substantial Completion, but not more than two months after Final Acceptance, perform an infrared scan of each panelboard, switchboard and pad mounted transformer. Remove fronts to make joints and connections accessible to a portable scanner.
- C. Instrument: Use an approved infrared scanning device designed to measure temperature or detect significant deviations from normal values. Provide calibration record for device used.
- D. Record of Infrared Scanning: Prepare a certified report identifying panelboards checked and describing results of scanning. Include notation of deficiencies detected, remedial action taken, and observations after remedial action.

END OF SECTION

SECTION 283111 - DIGITAL, ADDRESSABLE FIRE-ALARM SYSTEM

PART 1 - GENERAL

1.01 RELATED DOCUMENTS

- A. Drawings and general provisions of the Contract, including General and Supplementary Conditions and Division 01 Specification Sections, apply to this Section.

1.02 SUMMARY

- A. Section Includes:
 1. Fire-alarm control unit.
 2. Manual fire-alarm boxes.
 3. System smoke detectors.
 4. Nonsystem smoke detectors.
 5. Heat detectors.
 6. Notification appliances.
 7. Firefighters' two-way telephone communication service.
 8. Magnetic door holders.
 9. Remote annunciator.
 10. Addressable interface device.
 11. Digital alarm communicator transmitter.
 12. Radio alarm transmitter.
 13. System printer.

1.03 DEFINITIONS

- A. LED: Light-emitting diode.
- B. NICET: National Institute for Certification in Engineering Technologies.

1.04 SYSTEM DESCRIPTION

- A. Noncoded, UL-certified addressable system, with multiplexed signal transmission, dedicated to fire-alarm service only.

1.05 PERFORMANCE REQUIREMENTS

1.06 SUBMITTALS

- A. General Submittal Requirements:
 1. Submittals shall be approved by authorities having jurisdiction prior to submitting them to Architect.
 2. Shop Drawings shall be prepared by persons with the following qualifications:
 - a. Trained and certified by manufacturer in fire-alarm system design.
 - b. NICET-certified fire-alarm technician, Level III minimum.
 - c. Licensed or certified by authorities having jurisdiction.
- B. Product Data: For each type of product indicated.
- C. Shop Drawings: For fire-alarm system. Include plans, elevations, sections, details, and at-

tachments to other work.

1. Comply with recommendations in the "Documentation" Section of the "Fundamentals of Fire Alarm Systems" Chapter in NFPA 72.
 2. Include voltage drop calculations for notification appliance circuits.
 3. Include battery-size calculations.
 4. Include performance parameters and installation details for each detector, verifying that each detector is listed for complete range of air velocity, temperature, and humidity possible when air-handling system is operating.
 5. Include plans, sections, and elevations of heating, ventilating, and air-conditioning ducts, drawn to scale and coordinating installation of duct smoke detectors and access to them. Show critical dimensions that relate to placement and support of sampling tubes, detector housing, and remote status and alarm indicators. Locate detectors according to manufacturer's written recommendations.
 6. Include voice/alarm signaling-service equipment rack or console layout, grounding schematic, amplifier power calculation, and single-line connection diagram.
 7. Include floor plans to indicate final outlet locations showing address of each addressable device. Show size and route of cable and conduits.
- D. Delegated-Design Submittal: For smoke and heat detectors indicated to comply with performance requirements and design criteria, including analysis data signed and sealed by the qualified professional engineer responsible for their preparation.
1. Drawings showing the location of each smoke and heat detector, ratings of each, and installation details as needed to comply with listing conditions of the detector.
 2. Design Calculations: Calculate requirements for selecting the spacing and sensitivity of detection, complying with NFPA 72.
- E. Qualification Data: For qualified Installer.
- F. Field quality-control reports.
- G. Operation and Maintenance Data: For fire-alarm systems and components to include in emergency, operation, and maintenance manuals. In addition to items specified in Division 01 Section "Operation and Maintenance Data," include the following:
1. Comply with the "Records" Section of the "Inspection, Testing and Maintenance" Chapter in NFPA 72.
 2. Provide "Record of Completion Documents" according to NFPA 72 article "Permanent Records" in the "Records" Section of the "Inspection, Testing and Maintenance" Chapter.
 3. Record copy of site-specific software.
 4. Provide "Maintenance, Inspection and Testing Records" according to NFPA 72 article of the same name and include the following:
 5. Frequency of testing of installed components.
 6. Frequency of inspection of installed components.
 7. Requirements and recommendations related to results of maintenance.
 8. Manufacturer's user training manuals.
 9. Manufacturer's required maintenance related to system warranty requirements.
 10. Abbreviated operating instructions for mounting at fire-alarm control unit.
 11. Copy of NFPA 25.
- H. Software and Firmware Operational Documentation:

1. Software operating and upgrade manuals.
2. Program Software Backup: On magnetic media or compact disk, complete with data files.
3. Device address list.
4. Printout of software application and graphic screens.

1.07 QUALITY ASSURANCE

- A. Installer Qualifications: Personnel shall be trained and certified by manufacturer for installation of units required for this Project.
- B. Installer Qualifications: Installation shall be by personnel certified by NICET as fire-alarm Level III technician.
- C. Source Limitations for Fire-Alarm System and Components: Obtain fire-alarm system from single source from single manufacturer. Components shall be compatible with, and operate as, an extension of existing system.
- D. Electrical Components, Devices, and Accessories: Listed and labeled as defined in NFPA 70, by a qualified testing agency, and marked for intended location and application.
- E. NFPA Certification: Obtain certification according to NFPA 72 by a UL-listed alarm company.

1.08 PROJECT CONDITIONS

- A. Interruption of Existing Fire-Alarm Service: Do not interrupt fire-alarm service to facilities occupied by Owner or others unless permitted under the following conditions and then only after arranging to provide temporary guard service according to requirements indicated:
 1. Notify Owner no fewer than two weeks in advance of proposed interruption of fire-alarm service.
 2. Do not proceed with interruption of fire-alarm service without Owner's written permission.

1.09 SEQUENCING AND SCHEDULING

- A. Existing Fire-Alarm Equipment: Maintain existing equipment fully operational until new equipment has been tested and accepted. As new equipment is installed, label it "NOT IN SERVICE" until it is accepted. Remove labels from new equipment when put into service and label existing fire-alarm equipment "NOT IN SERVICE" until removed from the building.
- B. Equipment Removal: After acceptance of new fire-alarm system, remove existing disconnected fire-alarm equipment and wiring.

1.10 SOFTWARE SERVICE AGREEMENT

- A. Comply with UL 864.
- B. Technical Support: Beginning with Substantial Completion, provide software support for two years.
- C. Upgrade Service: Update software to latest version at Project completion. Install and program software upgrades that become available within two years from date of Substantial Completion. Upgrading software shall include operating system. Upgrade shall include new or revised licenses for use of software.
 1. Provide 30 days' notice to Owner to allow scheduling and access to system and to allow Owner to upgrade computer equipment if necessary.

1.11 EXTRA MATERIALS

- A. Furnish extra materials that match products installed and that are packaged with protective cov-

ering for storage and identified with labels describing contents.

1. Lamps for Remote Indicating Lamp Units: Quantity equal to 10 percent of amount installed, but no fewer than 1 unit.
2. Lamps for Strobe Units: Quantity equal to 10 percent of amount installed, but no fewer than 1 unit.
3. Smoke Detectors, Fire Detectors and Flame Detectors: Quantity equal to 10 percent of amount of each type installed, but no fewer than 1 unit of each type.
4. Detector Bases: Quantity equal to 2 percent of amount of each type installed, but no fewer than 1 unit of each type.
5. Keys and Tools: One extra set for access to locked and tamper-proofed components.
6. Audible and Visual Notification Appliances: two of each type installed.
7. Fuses: Two of each type installed in the system.

PART 2 - PRODUCTS

2.01 MANUFACTURERS

- A. Manufacturers: Subject to compliance with requirements, provide products as manufactured by Silent Knight. Silent Knight is the only acceptable manufacturer.

2.02 SYSTEMS OPERATIONAL DESCRIPTION

- A. Fire-alarm signal initiation shall be by one or more of the following devices and systems:
 1. Manual stations.
 2. Heat detectors.
 3. Flame detectors.
 4. Smoke detectors.
 5. Duct smoke detectors.
 6. Verified automatic alarm operation of smoke detectors.
 7. Automatic sprinkler system water flow.
 8. Heat detectors in elevator shaft and pit.
 9. Fire-extinguishing system operation.
 10. Fire standpipe system.
 11. Smoke Evacuation System.
- B. Fire-alarm signal shall initiate the following actions:
 1. Continuously operate alarm notification appliances.
 2. Identify alarm at fire-alarm control unit and remote annunciators.
 3. Transmit an alarm signal to the remote alarm receiving station.
 4. Unlock electric door locks in designated egress paths.
 5. Release fire and smoke doors held open by magnetic door holders.
 6. Activate voice/alarm communication system.
 7. Switch heating, ventilating, and air-conditioning equipment controls to fire-alarm mode.
 8. Activate smoke-control system (smoke management) at firefighter smoke-control system panel.
 9. Activate stairwell and elevator-shaft pressurization systems.
 10. Close smoke dampers in air ducts of designated air-conditioning duct systems.

11. Recall elevators to primary or alternate recall floors.
 12. Activate emergency lighting control.
 13. Activate emergency shutoffs for gas and fuel supplies.
 14. Record events in the system memory.
 15. Record events by the system printer.
- C. Supervisory signal initiation shall be by one or more of the following devices and actions:
1. Valve supervisory switch.
 2. Low-air-pressure switch of a dry-pipe sprinkler system.
 3. Elevator shunt-trip supervision.
- D. System trouble signal initiation shall be by one or more of the following devices and actions:
1. Open circuits, shorts, and grounds in designated circuits.
 2. Opening, tampering with, or removing alarm-initiating and supervisory signal-initiating devices.
 3. Loss of primary power at fire-alarm control unit.
 4. Ground or a single break in fire-alarm control unit internal circuits.
 5. Abnormal ac voltage at fire-alarm control unit.
 6. Break in standby battery circuitry.
 7. Failure of battery charging.
 8. Abnormal position of any switch at fire-alarm control unit or annunciator.
 9. Fire-pump power failure, including a dead-phase or phase-reversal condition.
 10. Low-air-pressure switch operation on a dry-pipe or preaction sprinkler system.
- E. System Trouble and Supervisory Signal Actions: Initiate notification appliance and annunciate at fire-alarm control unit and remote annunciators. Record the event on system printer.

2.03 FIRE-ALARM CONTROL PANEL

- A. The fire alarm control panel shall be Silent Knight SK-5820 5820XL or IFP-1000.
- B. All sub-panels shall be analog addressable (i.e. Power Booster) (*) Silent Knight– Model #5895XL.

2.04 MANUAL FIRE-ALARM BOXES

- A. General Requirements for Manual Fire-Alarm Boxes: Comply with UL 38. Boxes shall be finished in red with molded, raised-letter operating instructions in contrasting color; shall show visible indication of operation; and shall be mounted on recessed outlet box. If indicated as surface mounted, provide manufacturer's surface back box.
 1. Single-action mechanism, breaking-glass or plastic-rod type; with integral addressable module arranged to communicate manual-station status (normal, alarm, or trouble) to fire-alarm control unit.
 2. Double-action mechanism requiring two actions to initiate an alarm, breaking-glass or plastic-rod type; with integral addressable module arranged to communicate manual-station status (normal, alarm, or trouble) to fire-alarm control unit.
 3. Station Reset: Key- or wrench-operated switch.
 4. Indoor Protective Shield: Factory-fabricated clear plastic enclosure hinged at the top to permit lifting for access to initiate an alarm. Lifting the cover actuates an integral battery-powered audible horn intended to discourage false-alarm operation.

5. Weatherproof Protective Shield: Factory-fabricated clear plastic enclosure hinged at the top to permit lifting for access to initiate an alarm.

2.05 SYSTEM SMOKE DETECTORS

A. General Requirements for System Smoke Detectors:

1. Comply with UL 268; operating at 24-V dc, nominal.
2. Integral Addressable Module: Arranged to communicate detector status (normal, alarm, or trouble) to fire-alarm control unit.
3. Base Mounting: Detector and associated electronic components shall be mounted in a twist-lock module that connects to a fixed base. Provide terminals in the fixed base for connection to building wiring.
4. Self-Restoring: Detectors do not require resetting or readjustment after actuation to restore them to normal operation.
5. Integral Visual-Indicating Light: LED type indicating detector has operated and power-on status.
 - a. Provide multiple levels of detection sensitivity for each sensor.

B. Photoelectric Smoke Detectors:

1. Detector address shall be accessible from fire-alarm control unit and shall be able to identify the detector's location within the system and its sensitivity setting.
2. An operator at fire-alarm control unit, having the designated access level, shall be able to manually access the following for each detector:
 - a. Primary status.
 - b. Device type.
 - c. Present average value.
 - d. Present sensitivity selected.
 - e. Sensor range (normal, dirty, etc.).

C. Ionization Smoke Detector:

1. Detector address shall be accessible from fire-alarm control unit and shall be able to identify the detector's location within the system and its sensitivity setting.
2. An operator at fire-alarm control unit, having the designated access level, shall be able to manually access the following for each detector:
 - a. Primary status.
 - b. Device type.
 - c. Present average value.
 - d. Present sensitivity selected.
 - e. Sensor range (normal, dirty, etc.).

D. Duct Smoke Detectors: Photoelectric type complying with UL 268A.

1. Detector address shall be accessible from fire-alarm control unit and shall be able to identify the detector's location within the system and its sensitivity setting.
2. An operator at fire-alarm control unit, having the designated access level, shall be able to manually access the following for each detector:
 - a. Primary status.
 - b. Device type.
 - c. Present average value.

- d. Present sensitivity selected.
- e. Sensor range (normal, dirty, etc.).
- 3. Weatherproof Duct Housing Enclosure: NEMA 250, Type 4X; NRTL listed for use with the supplied detector.
- 4. Each sensor shall have multiple levels of detection sensitivity.
- 5. Sampling Tubes: Design and dimensions as recommended by manufacturer for specific duct size, air velocity, and installation conditions where applied.
- 6. Relay Fan Shutdown: Rated to interrupt fan motor-control circuit.

2.06 NONSYSTEM SMOKE DETECTORS

- A. Single-Station Duct Smoke Detectors:
 - 1. Comply with UL 268A; operating at 120-V ac.
 - 2. Sensor: LED or infrared light source with matching silicon-cell receiver.
 - a. Detector Sensitivity: Smoke obscuration between 2.5 and 3.5 percent/foot when tested according to UL 268A.
 - 3. Base Mounting: Detector and associated electronic components shall be mounted in a twist-lock module that connects to a fixed base. The fixed base shall be designed for mounting directly to air duct. Provide terminals in the fixed base for connection to building wiring.
 - a. Weatherproof Duct Housing Enclosure: NEMA 250, Type 4X; NRTL listed for use with the supplied detector.
 - 4. Sampling Tubes: Design and dimensions as recommended by manufacturer for specific duct size, air velocity, and installation conditions where applied.
 - 5. Relay Fan Shutdown: Rated to interrupt fan motor-control circuit.

2.07 HEAT DETECTORS

- A. General Requirements for Heat Detectors: Comply with UL 521.
- B. Heat Detector, Combination Type: Actuated by either a fixed temperature of 135 deg F or a rate of rise that exceeds 15 deg per minute unless otherwise indicated.
 - 1. Mounting: Twist-lock base interchangeable with smoke-detector bases.
 - 2. Integral Addressable Module: Arranged to communicate detector status (normal, alarm, or trouble) to fire-alarm control unit.

2.08 NOTIFICATION APPLIANCES

- A. General Requirements for Notification Appliances: Individually addressed, connected to a signaling line circuit, equipped for mounting as indicated and with screw terminals for system connections.
- B. General Requirements for Notification Appliances: Connected to notification appliance signal circuits, zoned as indicated, equipped for mounting as indicated and with screw terminals for system connections.
 - 1. Combination Devices: Factory-integrated audible and visible devices in a single-mounting assembly, equipped for mounting as indicated and with screw terminals for system connections.
- C. Chimes, Low-Level Output: Vibrating type, 75-dBA minimum rated output.
- D. Chimes, High-Level Output: Vibrating type, 81-dBA minimum rated output.
- E. Horns: Electric-vibrating-polarized type, 24-V dc; with provision for housing the operating

mechanism behind a grille. Comply with UL 464. Horns shall produce a sound-pressure level of 90 dBA, measured 10 feet from the horn, using the coded signal prescribed in UL 464 test protocol.

- F. Visible Notification Appliances: Xenon strobe lights comply with UL 1971, with clear or nominal white polycarbonate lens mounted on an aluminum faceplate. The word "FIRE" is engraved in minimum 1-inch high letters on the lens.
 - 1. Mounting: Wall mounted unless otherwise indicated.
 - 2. For units with guards to prevent physical damage, light output ratings shall be determined with guards in place.
 - 3. Flashing shall be in a temporal pattern, synchronized with other units.
 - 4. Strobe Leads: Factory connected to screw terminals.
 - 5. Mounting Faceplate: Factory finished red.
- G. Voice/Tone Notification Appliances:
 - 1. Appliances shall comply with UL 1480 and shall be listed and labeled by an NRTL.
 - 2. High-Range Units: Rated 2 to 15 W.
 - 3. Low-Range Units: Rated 1 to 2 W.
 - 4. Mounting: Flush or surface mounted and bidirectional.
 - 5. Matching Transformers: Tap range matched to acoustical environment of speaker location.

2.09 FIREFIGHTERS' TWO-WAY TELEPHONE COMMUNICATION SERVICE

- A. Dedicated, two-way, supervised, telephone voice communication links between fire-alarm control unit and remote firefighters' telephone stations. Supervised telephone lines shall be connected to talk circuits by controls in a control module. Provide the following:
 - 1. Selective-talk type for use by firefighters and fire wardens.
 - 2. Controls to disconnect phones from talk circuits if too many phones are in use simultaneously.
 - 3. Audible Pulse and Tone Generator, and High-Intensity Lamp: When a remote telephone is activated, it causes audible signal to sound and high-intensity lamp to flash.
 - 4. Selector panel controls shall provide for simultaneous operation of up to six telephones in selected zones. Indicate ground faults and open or shorted telephone lines on the panel front by individual LEDs.
 - 5. Display: Graphic to indicate location of caller.
 - 6. Remote Telephone Cabinet: Flush- or surface-mounted cabinet as indicated, factory-standard red finish, with handset.
 - a. Install one-piece handset to cabinet with vandal-resistant armored cord. Silk-screened or engraved label on cabinet door, designating "Fire Emergency Phone."
 - b. With "break-glass" type door access lock.

2.10 MAGNETIC DOOR HOLDERS

- A. Description: Units are equipped for wall or floor mounting as indicated and are complete with matching doorplate.
 - 1. Electromagnet: Requires no more than 3 W to develop 25-lbf holding force.
 - 2. Wall-Mounted Units: Flush mounted unless otherwise indicated.
 - 3. Rating: 24-V ac or dc.
- B. Material and Finish: Match door hardware.

2.11 REMOTE ANNUNCIATOR

- A. Description: Annunciator functions shall match those of fire-alarm control unit for alarm, supervisory, and trouble indications. Manual switching functions shall match those of fire-alarm control unit, including acknowledging, silencing, resetting, and testing.
 - 1. Mounting: Flush or Surface cabinet, NEMA 250, Type 1.
- B. Display Type and Functional Performance: Alphanumeric display and LED indicating lights shall match those of fire-alarm control unit. Provide controls to acknowledge, silence, reset, and test functions for alarm, supervisory, and trouble signals.

2.12 ADDRESSABLE INTERFACE DEVICE

- A. Description: Microelectronic monitor module, NRTL listed for use in providing a system address for alarm-initiating devices for wired applications with normally open contacts.
- B. Integral Relay: Capable of providing a direct signal to elevator controller to initiate elevator recall.

2.13 DIGITAL ALARM COMMUNICATOR TRANSMITTER

- A. Digital alarm communicator transmitter shall be acceptable to the remote central station and shall comply with UL 632 and be listed and labeled by an NRTL.
- B. Functional Performance: Unit shall receive an alarm, supervisory, or trouble signal from fire-alarm control unit and automatically capture two telephone line(s) and dial a preset number for a remote central station. When contact is made with central station(s), signals shall be transmitted. If service on line is interrupted for longer than 45 seconds, transmitter shall initiate a local trouble signal and transmit the signal indicating loss of telephone line to the remote alarm receiving station over the remaining line. Transmitter shall automatically report telephone service restoration to the central station. If service is lost on both telephone lines, transmitter shall initiate the local trouble signal.
- C. Local functions and display at the digital alarm communicator transmitter shall include the following:
 - 1. Verification that both telephone lines are available.
 - 2. Programming device.
 - 3. LED display.
 - 4. Manual test report function and manual transmission clear indication.
 - 5. Communications failure with the central station or fire-alarm control unit.
- D. Digital data transmission shall include the following:
 - 1. Address of the alarm-initiating device.
 - 2. Loss of ac supply or loss of power.
 - 3. Low battery.
 - 4. Abnormal test signal.
 - 5. Communication bus failure.
- E. Secondary Power: Integral rechargeable battery and automatic charger.
- F. Self-Test: Conducted automatically every 24 hours with report transmitted to central station.

2.14 SYSTEM PRINTER

- A. Printer shall be listed and labeled by an NRTL as an integral part of fire-alarm system.

2.15 DEVICE GUARDS

- A. Description: Welded wire mesh of size and shape for the manual station, smoke detector, gong, or other device requiring protection.
 - 1. Factory fabricated and furnished by manufacturer of device.
 - 2. Finish: Paint of color to match the protected device.

PART 3 - EXECUTION

3.01 EQUIPMENT INSTALLATION

- A. Comply with NFPA 72 for installation of fire-alarm equipment.
- B. Equipment Mounting: Install fire-alarm control unit on concrete base with tops of cabinets not more than 72 inches above the finished floor. Comply with requirements for concrete base specified in Division 03 Section."
 - 1. Install dowel rods to connect concrete base to concrete floor. Unless otherwise indicated, install dowel rods on 18-inch centers around the full perimeter of concrete base.
 - 2. For supported equipment, install epoxy-coated anchor bolts that extend through concrete base and anchor into structural concrete floor.
 - 3. Place and secure anchorage devices. Use setting drawings, templates, diagrams, instructions, and directions furnished with items to be embedded.
 - 4. Install anchor bolts to elevations required for proper attachment to supported equipment.
- C. Equipment Mounting: Install fire-alarm control unit on finished floor with tops of cabinets not more than 72 inches above the finished floor.
- D. Smoke- or Heat-Detector Spacing:
 - 1. Comply with NFPA 72, "Smoke-Sensing Fire Detectors" Section in the "Initiating Devices" Chapter, for smoke-detector spacing.
 - 2. Comply with NFPA 72, "Heat-Sensing Fire Detectors" Section in the "Initiating Devices" Chapter, for heat-detector spacing.
 - 3. Smooth ceiling spacing shall not exceed 30 feet.
 - 4. Spacing of detectors for irregular areas, for irregular ceiling construction, and for high ceiling areas shall be determined according to Appendix A in NFPA 72.
 - 5. HVAC: Locate detectors not closer than 3 feet from air-supply diffuser or return-air opening.
 - 6. Lighting Fixtures: Locate detectors not closer than 12 inches from any part of a lighting fixture.
- E. Duct Smoke Detectors: Comply with NFPA 72 and NFPA 90A. Install sampling tubes so they extend the full width of duct.
- F. Heat Detectors in Elevator Shafts: Coordinate temperature rating and location with sprinkler rating and location.
- G. Single-Station Smoke Detectors: Where more than one smoke alarm is installed within a dwelling or suite, they shall be connected so that the operation of any smoke alarm causes the alarm in all smoke alarms to sound.
- H. Remote Status and Alarm Indicators: Install near each smoke detector and each sprinkler water-flow switch and valve-tamper switch that is not readily visible from normal viewing position.
- I. Audible Alarm-Indicating Devices: Install not less than 6 inches below the ceiling. Install bells and horns on flush-mounted back boxes with the device-operating mechanism concealed

behind a grille.

- J. Visible Alarm-Indicating Devices: Install adjacent to each alarm bell or alarm horn and at least 6 inches below the ceiling.
- K. Device Location-Indicating Lights: Locate in public space near the device they monitor.
- L. Fire-Alarm Control Unit: Surface mounted, with tops of cabinets not more than 72 inches above the finished floor.
- M. Annunciator: Install with top of panel not more than 72 inches above the finished floor.

3.02 CONNECTIONS

- A. For fire-protection systems related to doors in fire-rated walls and partitions and to doors in smoke partitions, comply with requirements in Division 08 Section "Door Hardware." Connect hardware and devices to fire-alarm system.
 - 1. Verify that hardware and devices are NRTL listed for use with fire-alarm system in this Section before making connections.
- B. Make addressable connections with a supervised interface device to the following devices and systems. Install the interface device less than 3 feet from the device controlled. Make an addressable confirmation connection when such feedback is available at the device or system being controlled.
 - 1. Alarm-initiating connection to smoke-control system (smoke management) at firefighter smoke-control system panel.
 - 2. Alarm-initiating connection to stairwell and elevator-shaft pressurization systems.
 - 3. Smoke dampers in air ducts of designated air-conditioning duct systems.
 - 4. Alarm-initiating connection to elevator recall system and components.
 - 5. Alarm-initiating connection to activate emergency lighting control.
 - 6. Alarm-initiating connection to activate emergency shutoffs for gas and fuel supplies.
 - 7. Supervisory connections at valve supervisory switches.
 - 8. Supervisory connections at low-air-pressure switch of each dry-pipe sprinkler system.
 - 9. Supervisory connections at elevator shunt trip breaker.
 - 10. Supervisory connections at fire-pump power failure including a dead-phase or phase-reversal condition.

3.03 IDENTIFICATION

- A. Identify system components, wiring, cabling, and terminals. Comply with requirements for identification specified in Division 26 Section "Identification for Electrical Systems."
- B. Install framed instructions in a location visible from fire-alarm control unit.

3.04 GROUNDING

- A. Ground fire-alarm control unit and associated circuits; comply with IEEE 1100. Install a ground wire from main service ground to fire-alarm control unit.

3.05 FIELD QUALITY CONTROL

- A. Field tests shall be witnessed by authorities having jurisdiction.
- B. Manufacturer's Field Service: Engage a factory-authorized service representative to inspect, test, and adjust components, assemblies, and equipment installations, including connections.
- C. Perform tests and inspections.

1. Manufacturer's Field Service: Engage a factory-authorized service representative to inspect components, assemblies, and equipment installations, including connections, and to assist in testing.
- D. Tests and Inspections:
1. Visual Inspection: Conduct visual inspection prior to testing.
 - a. Inspection shall be based on completed Record Drawings and system documentation that is required by NFPA 72 in its "Completion Documents, Preparation" Table in the "Documentation" Section of the "Fundamentals of Fire Alarm Systems" Chapter.
 - b. Comply with "Visual Inspection Frequencies" Table in the "Inspection" Section of the "Inspection, Testing and Maintenance" Chapter in NFPA 72; retain the "Initial/Reacceptance" column and list only the installed components.
 2. System Testing: Comply with "Test Methods" Table in the "Testing" Section of the "Inspection, Testing and Maintenance" Chapter in NFPA 72.
 3. Test audible appliances for the public operating mode according to manufacturer's written instructions. Perform the test using a portable sound-level meter complying with Type 2 requirements in ANSI S1.4.
 4. Test audible appliances for the private operating mode according to manufacturer's written instructions.
- E. Reacceptance Testing: Perform reacceptance testing to verify the proper operation of added or replaced devices and appliances.
- F. Fire-alarm system will be considered defective if it does not pass tests and inspections.
- G. Prepare test and inspection reports.
- H. Maintenance Test and Inspection: Perform tests and inspections listed for weekly, monthly, quarterly, and semiannual periods. Use forms developed for initial tests and inspections.
- I. Annual Test and Inspection: One year after date of Substantial Completion, test fire-alarm system complying with visual and testing inspection requirements in NFPA 72. Use forms developed for initial tests and inspections.

3.06 DEMONSTRATION

- A. Engage a factory-authorized service representative to train Owner's maintenance personnel to adjust, operate, and maintain fire-alarm system.

END OF SECTION

BAYSIDE COMMUNITY CENTER

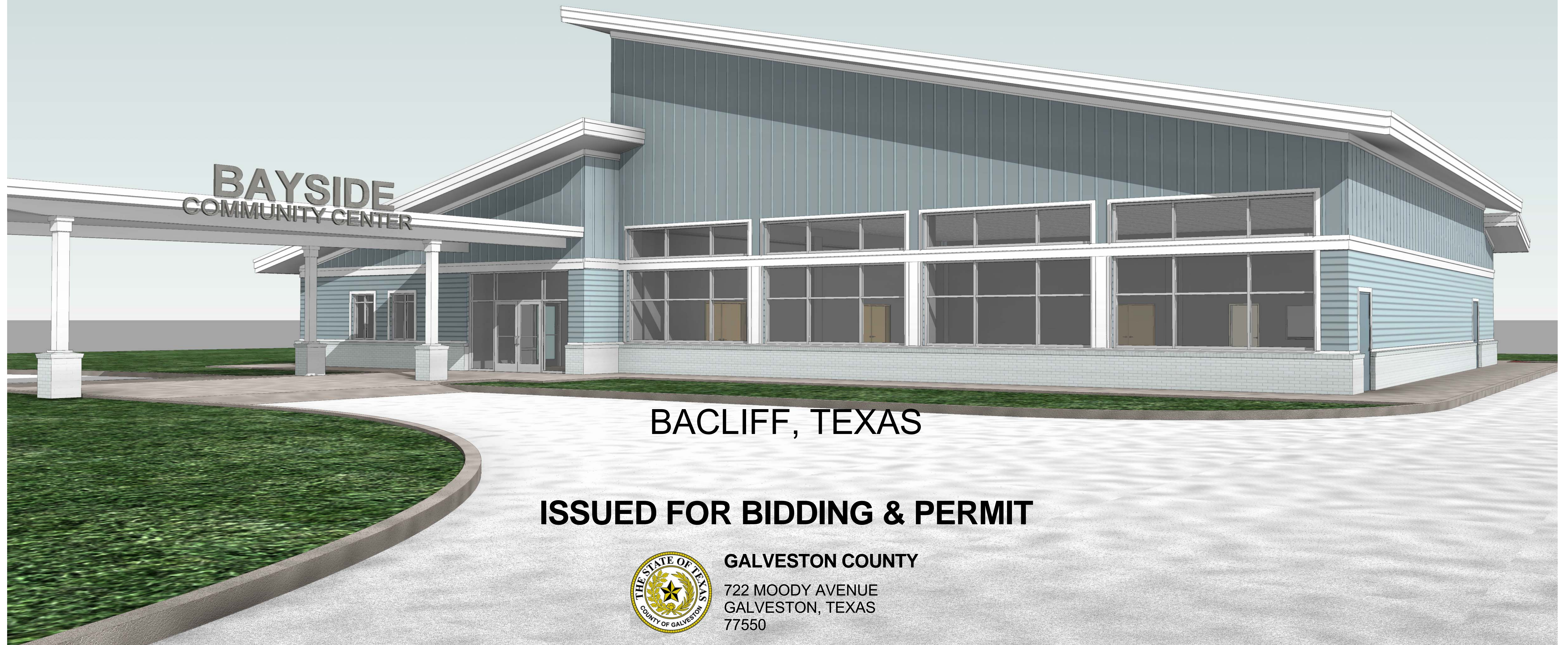

BACLIFF, TEXAS

ISSUED FOR BIDDING & PERMIT



GALVESTON COUNTY

722 MOODY AVENUE
GALVESTON, TEXAS
77550

MEP

STRUCTURE

ARCHITECT



INFRASTRUCTURE ASSOCIATES, INC.
6117 RICHMOND AVENUE, SUITE 200
HOUSTON, TEXAS 77057
TBPE REGISTRATION NO. F-4506
(713) 622-0120 PH (713) 622-0557 FAX
WWW.IAHOUSTON.COM



9800 Richmond Avenue, Suite 460
Houston, Texas 77042 t 713 337 8881
TEXAS REGISTERED ENGINEERING FIRM
F-003426



Boucher Design Group LLC
Members A.I.A.
6802 Mapleridge, Suite 200
Bellaire, Texas 77401
Tel. 713.785.3644
www.bdgap.com

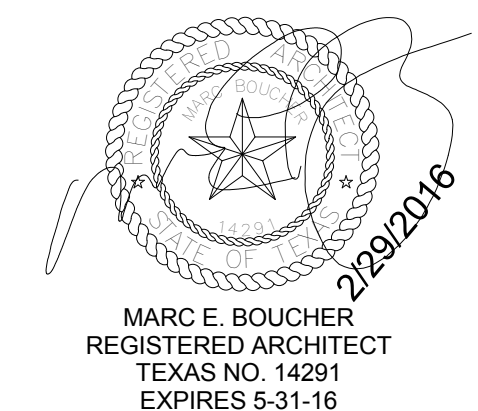

This document is an instrument of service protected by the copyright law of the United States of America, 17 U.S.C. §102, and shall not be copied or reproduced without the express written consent of Boucher Design Group, LLC, 2016

PROJECT #: 1409000
DATE: 2/29/2016

ISSUE	DATE	DESCRIPTION
3	5/16/16	VALUE ENGINEERING

DRAWING SYMBOLS

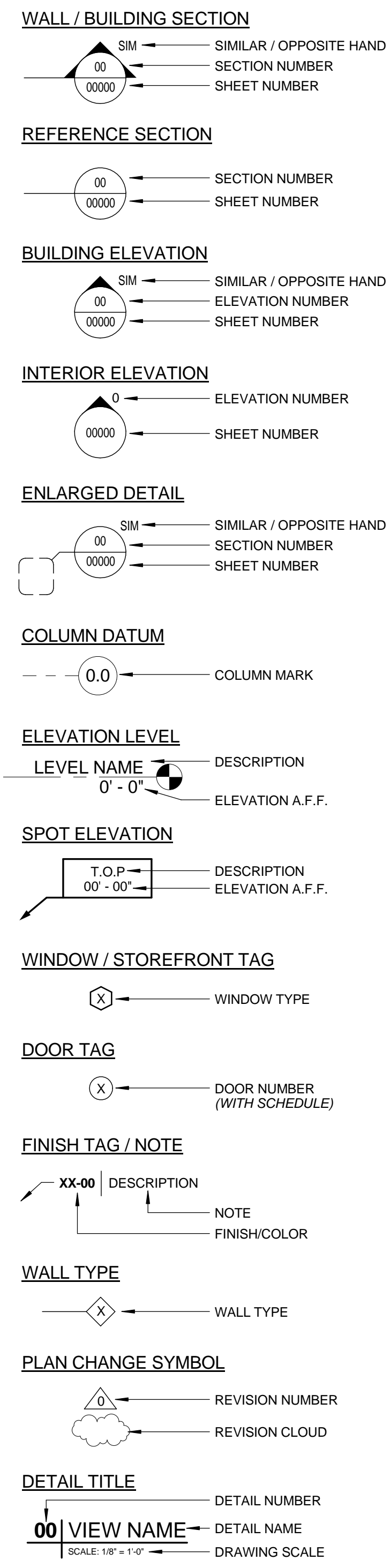

MATERIAL SYMBOLS

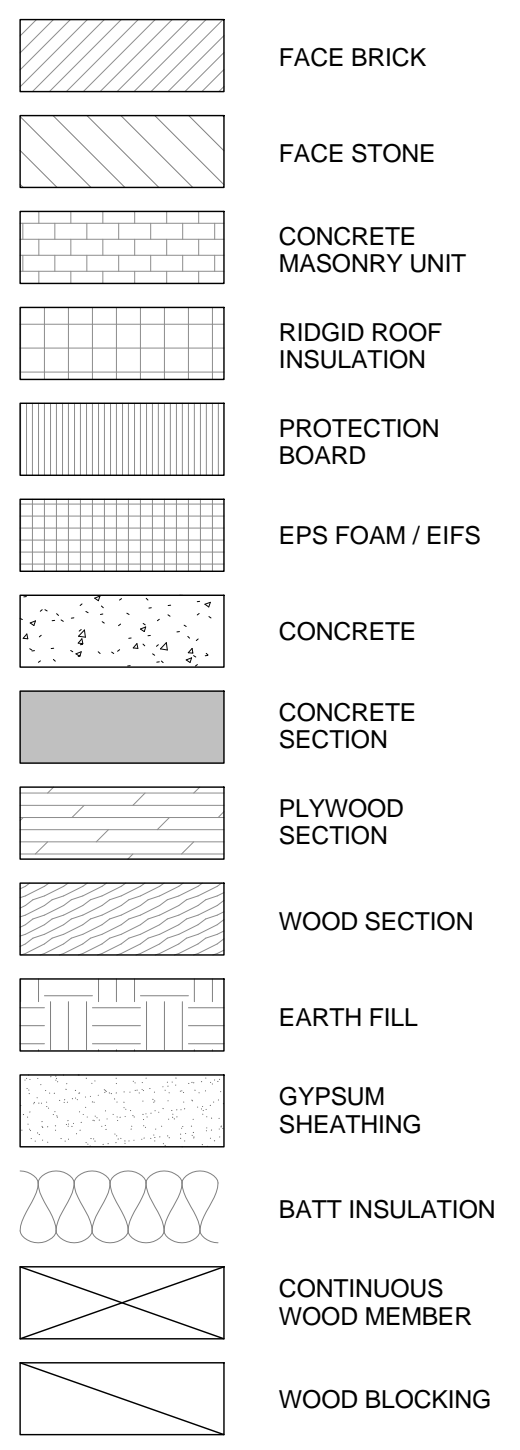

ABBREVIATIONS

Ø	DIAMETER	JT.	JOINT
&	AND	LAM.	LAMINATED
@	AT	LAV.	LAVATORY
#	CENTERLINE	LT.	LIGHT
0	EXISTING	MAX.	MAXIMUM
A.B.	ANCHOR BOLT	M.B.	MACHINE BOLT
ABV.	ABOVE	M.D.	MEDIUM DENSITY
ADD.	ADDENDUM	MECH.	MECHANICAL
AC	AIR CONDITIONING	MTL.	METAL
ACOUS.	ACOUSTICAL	MFR.	MANUFACTURER
AFF	ABOVE FINISH FLOOR	M.H.	MANHOLE
ALUM.	ALUMINUM	MGR.	MANAGER
APPROX.	APPROXIMATE	MFG.	MANUFACTURING
ARCH.	ARCHITECTURAL	MIN.	MINIMUM
BD.	BOARD	MISC.	MISCELLANEOUS
BLDG.	BUILDING	M.O.	MASONRY OPENING
BLKG.	BLOCK	MTD.	MOUNTED
BM.	BLOCKING	MUL.	MULLION
BOT.	BEAM	N.I.C.	NOT IN CONTRACT
BTWN.	BOTTOM	NO.	NUMBER
B.U.R.	BETWEEN BUILT UP ROOF	NOM.	NOMINAL
CATV	CABLE TELEVISION	N.T.S.	NOT TO SCALE
C.B.	CHALKBOARD	O.A.	OVERALL
CEM.	CEMENT	O.C.	ON CENTER
CER.	CERAMIC	O.D.	OUTSIDE DIAMETER
C.I.	CAST IRON	O.H.	OPPOSITE HAND
C.J.	CONTROL JOINT	OPP.	OPENING OPPOSITE
CLG.	CEILING	PERP.	PERPENDICULAR
CLR.	CLEAR	PARTN.	PARTITION
C.M.U.	CONCRETE MASONRY UNIT	P.L.	PROPERTY LINE
C.O.	CLEAR OPENING	PLAS.	PLASTIC
C/O	CLEAN OUT	PLBG.	PLUMBING
COL.	COLUMN	P.C.	PLAN CHANGE
CONC.	CONCRETE	PLYWD.	PLYWOOD
CONN.	CONNECTION	PR.	PAIR
CONSTR.	CONSTRUCTION	P.T.	PRESSURE TREATED
CONT.	CONTINUOUS	Q.T.	QUARRY TILE
CONTR.	CONTRACTOR	R.	RADIUS
C.Y.	CUBIC YARD	R.D.	ROOF DRAIN
DBL.	DOUBLE	RDWD.	REDWOOD
DEPT.	DEPARTMENT	REF.	REFERENCE
D.F.	DRINKING FOUNTAIN	REFR.	REFRIGERATOR
DIA.	DIAMETER	REIN.	REINFORCED
DIM.	DIMENSION	REQ'D.	REQUIRED
DN	DOWN	RESIL.	RESILIENT
DR	DOOR	R & S	ROD AND SHELF
DS	DOWNSPOUT	RM.	ROOM
DWG.	DRAWING	R.O.	ROUGH OPENING
EA.	EACH	R.O.W.	RIGHT OF WAY
EIFS	EXTERIOR INSULATING FINISHING SYSTEM	R.S.	ROUGH SAWN
E.J.	EXPANSION JOINT	SUSP.	SUSPENDED
ELEC.	ELECTRICAL	S.C.	SOLID CORE
ELEV.	ELEVATION	SCHED.	SCHEDULE
EQ.	EQUAL	SECT.	SECTION
EQUIP.	EQUIPMENT	SHT.	SHEET
E.W.	EACH WAY	SHTG.	SHEATHING
EXIST.	EXISTING	SK.	SINK
EXT.	EXTERIOR	SIM.	SIMILAR
F.D.	FLOOR DRAIN	SPEC.	SPECIFICATION
F.F.	FINISH FLOOR	SQ.	SQUARE
FIN.	FINISH	S.S.	STAINLESS STEEL
FIXT.	FIXTURE	STD.	STANDARD
FLR.	FLOOR	STL.	STEEL
F.L.	FLOOR LINE	STOR.	STORAGE
FLUOR.	FLUORESCENT	STRUCT.	STRUCTURAL
F.H.	FIRE HYDRANT	SYM.	SYMMETRICAL
F.O.F.	FACE OF FINISH	T.B.	TACK BOARD
F.O.M.	FACE OF MASONRY	T.O.B.	TOP OF BEAM
F.O.S.	FACE OF STUD	T.O.C.	TOP OF CURB
F.S.	FLOOR SINK	TEL.	TELEPHONE
FT.	FOOT/FEET	T&G	TONGUE AND GROOVE
FTG.	FOOTING	THK.	THICK
F.V.	FIELD VERIFY	T.O.P.	TOP OF PARAPET
GA.	GALVE	T.O.R.	TOP OF ROOF
GALV.	GALVANIZED	T.O.W.	TOP OF WALL
GL.	GLASS	T.P.	TOP OF PAVING
GND.	GROUND	TYP.	TYPICAL
GR.	GRADE	U.O.N.	UNLESS OTHERWISE NOTED
GYP.	GYPSUM	UR.	URINAL
HAND.	HANDICAP	V.W.C.	VINYL WALL COVERING
H.B.	HOSE BIBB	VERT.	VERTICAL
H.C.	HOLLOW CORE	V.T.R.	VENT THROUGH ROOF
HDR.	HEADER	V.C.T.	VINYL COMPOSITION TILE
HDW.	HARDWARE	W/	WITH
HT.	HEIGHT	W.C.	WATER CLOSET
H.M.	HOLLOW METAL	WD.	WOOD
HORIZ.	HORIZONTAL	W.H.	WATER HEATER
HT.	HEATING	WO	WITHOUT
HDWD.	HARDWOOD	W.P.	WEATHERPROOF
HVAC	HEATING, VENTILATION & AIR CONDITIONING	W.R.	WATER RESISTANT
I.D.	INSIDE DIAMETER	W.W.F.	WELDED WIRE FABRIC
IN.	INCH		
INSUL.	INSULATION		
INT.	INTERIOR		

DRAWING INDEX

ARCHITECTURAL		MEP SITE	
A000	COVER SHEET	MEP 101	SITE PLAN
A001	PROJECT INFORMATION		
A101	MASTER SITE PLAN		
A102	SITE PLAN		
A103	SIDEWALK PLAN		
A104	DUMPSTER / AC ENCLOSURE DETAILS		
A105	SITE DETAILS		
A200	FLOOR PLAN		
A200A	FINISH FLOOR PLAN		
A201	ROOF PLAN		
A202	ENLARGED RESTROOM PLAN & ELEVATIONS		
A203	POLE BARN		
A203A	POLE BARN ENLARGED PLAN		
A300	EXTERIOR ELEVATIONS		
A400	WALL SECTIONS		
A401	WALL SECTIONS		
A402	WALL SECTIONS		
A403	WALL SECTIONS		
A404	SECTION DETAILS		
A600	INTERIOR ELEVATIONS		
A701	DOOR AND WINDOW TYPES		
A702	HEAD, JAMB, SILL DETAILS		
A800	REFLECTED CEILING PLAN		

MECHANICAL

M101	NOTES AND LEGENDS
M102	SCHEDULES
M201	HVAC FLOOR PLAN
M301	DETAILS

ELECTRICAL

E101	SYMBOL LEGEND
E102	NOTES AND SCHEDULES
E110	ONE LINE DIAGRAM
E201	ELECTRICAL FLOOR PLAN - POWER
E211	EQUIPMENT PLAN - POWER
E301	REFLECTED CEILING PLAN - LIGHTING
E401	FLOOR PLAN - SPECIAL SYSTEMS
E501	DETAILS
E502	DETAILS

PLUMBING

P101	SCHEDULES, NOTES, AND LEGENDS
P201	PLUMBING FLOOR PLAN - SANITARY
P301	PLUMBING FLOOR PLAN - DOMESTIC
P401	RISER DIAGRAMS
P501	DETAILS
P502	DETAILS

STRUCTURAL

S101	GENERAL STRUCTURAL CRITERIA
S102	GENERAL STRUCTURAL CRITERIA
S201	FOUNDATION PLAN
S202	LOW ROOF / CANOPY FRAMING PLAN
S203	ROOF FRAMING PLAN
S204	HIGH ROOF FRAMING PLAN
S205	POLE BARN PLAN
S301	DRILLED PIER & PLINTH SCHEDULE & DETAILS
S302	COLUMN SCHEDULE
S501	TYPICAL FOUNDATION DETAILS
S502	FOUNDATION DETAILS
S601	FRAMING DETAILS
S602	POLE BARN FRAMING DETAILS
S701	TYPICAL FRAMING DETAILS

CODE DATA

BAYSIDE COMMUNITY CENTER

PARKING SPACES: 158 SPACES

HANDICAP: 1 VAN, 4 ACCESSIBLE

TOTAL PARKING: 163 SPACES

BUILDING AREA: 8,066 S.F.

OCCUPANCY: A-3

BUILDING TYPE: V-B

SPRINKLERED: NO

EXITS REQUIRED: 3

EXITS PROVIDED: 5

PROJECT INFO

CODE DATA: 2006 IBC W/ TDI AMENDMENTS AND TEXAS REVISIONS, 120MPH 3 SECOND GUST DESIGN WIND SPEED

2006 IPC
 2006 IFC
 2009 IECC
 2006 IMC
 2014 NEC

NOTE: ALL CONSTRUCTION MUST BE CERTIFIED WIND STORM RESISTANT BY A CERTIFIED TWIA INSPECTOR. A WPH-8 MUST BE PROVIDED BEFORE 100% APPLICATION FOR PAYMENT AND REQUEST FOR RELEASE OF RETAINAGE

VACINITY MAP

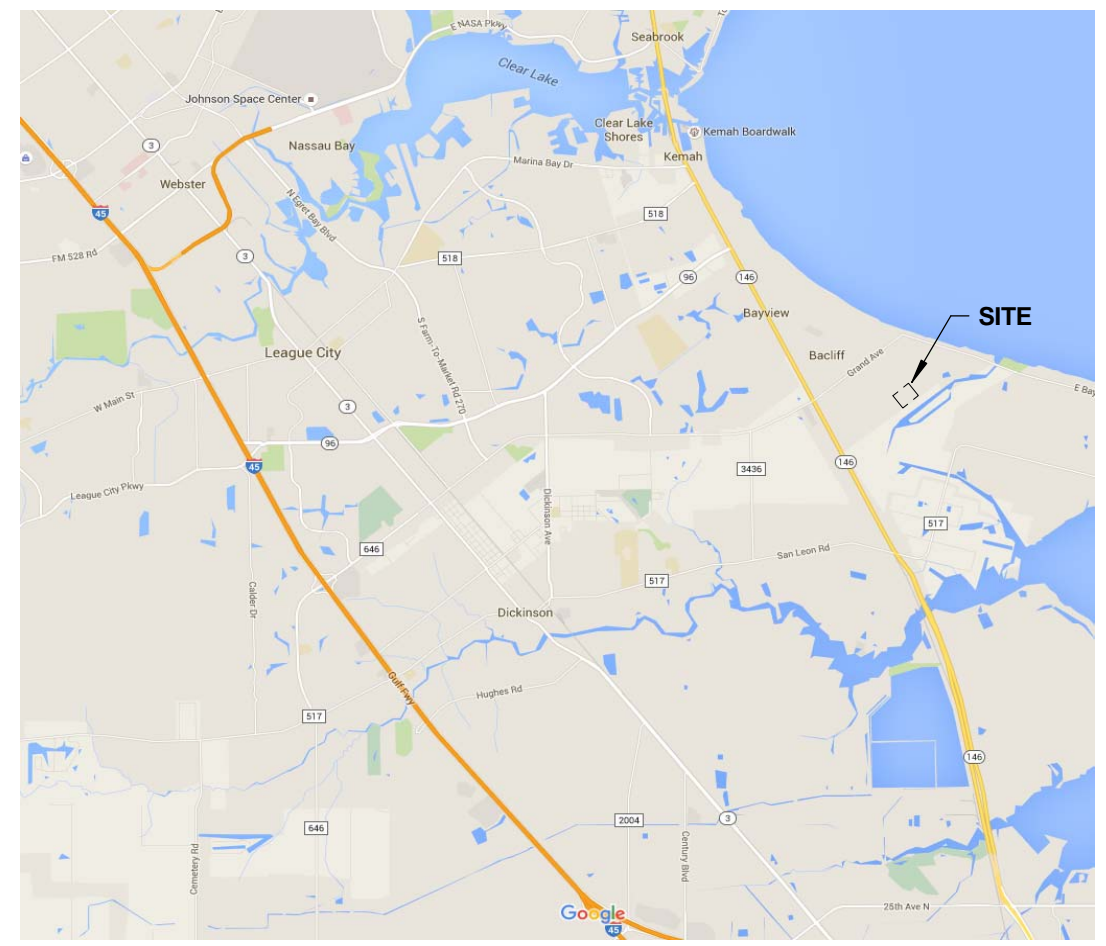

LOCATION MAP

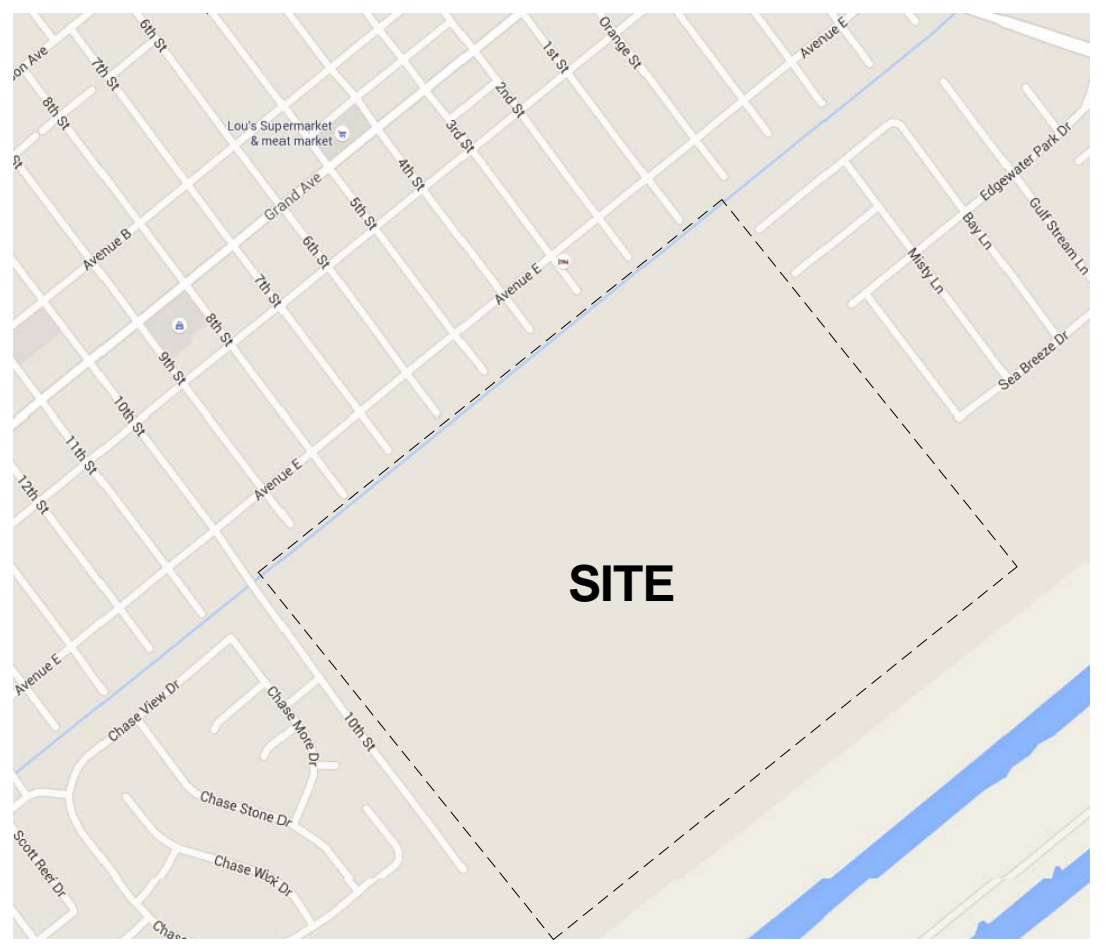

Boucher Design Group LLC
 Members A.I.A.
 6802 Maple Ridge, Suite 200
 Bellaire, Texas 77401
 Tel. 713.785.3644
 www.bdgap.com

This document is an instrument of service protected by the copyright law of the United States of America, 17 U.S.C. § 102, and shall not be copied or reproduced without the express written consent of Boucher Design Group, LLC. 2016

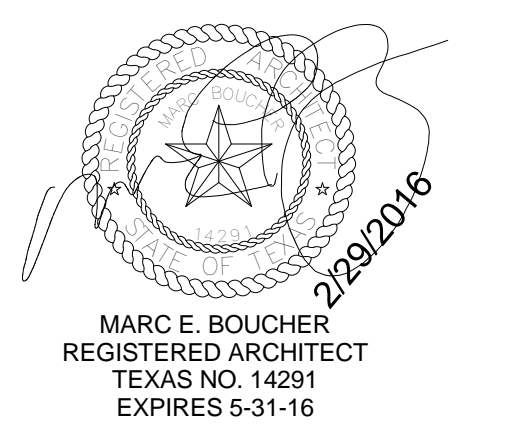

BAYSIDE COMMUNITY CENTER

BACLIFF, TEXAS
 GALVESTON COUNTY

DATE	12/08/2015
PROJECT NO.	1409000
DRAWN BY	BW
CHECKED BY	BA

PROJECT INFORMATION

A001
 © COPYRIGHT 2016 BOUCHER DESIGN GROUP, LLC

C:\Users\bdg\Documents\REVIT PROJECTS\1409000_GALVESTON COMMUNITY CENTER_bdm.rvt 6/9/2016 10:23:39 AM

ISSUE	DATE	DESCRIPTION
3	5/16/16	VALUE ENGINEERING

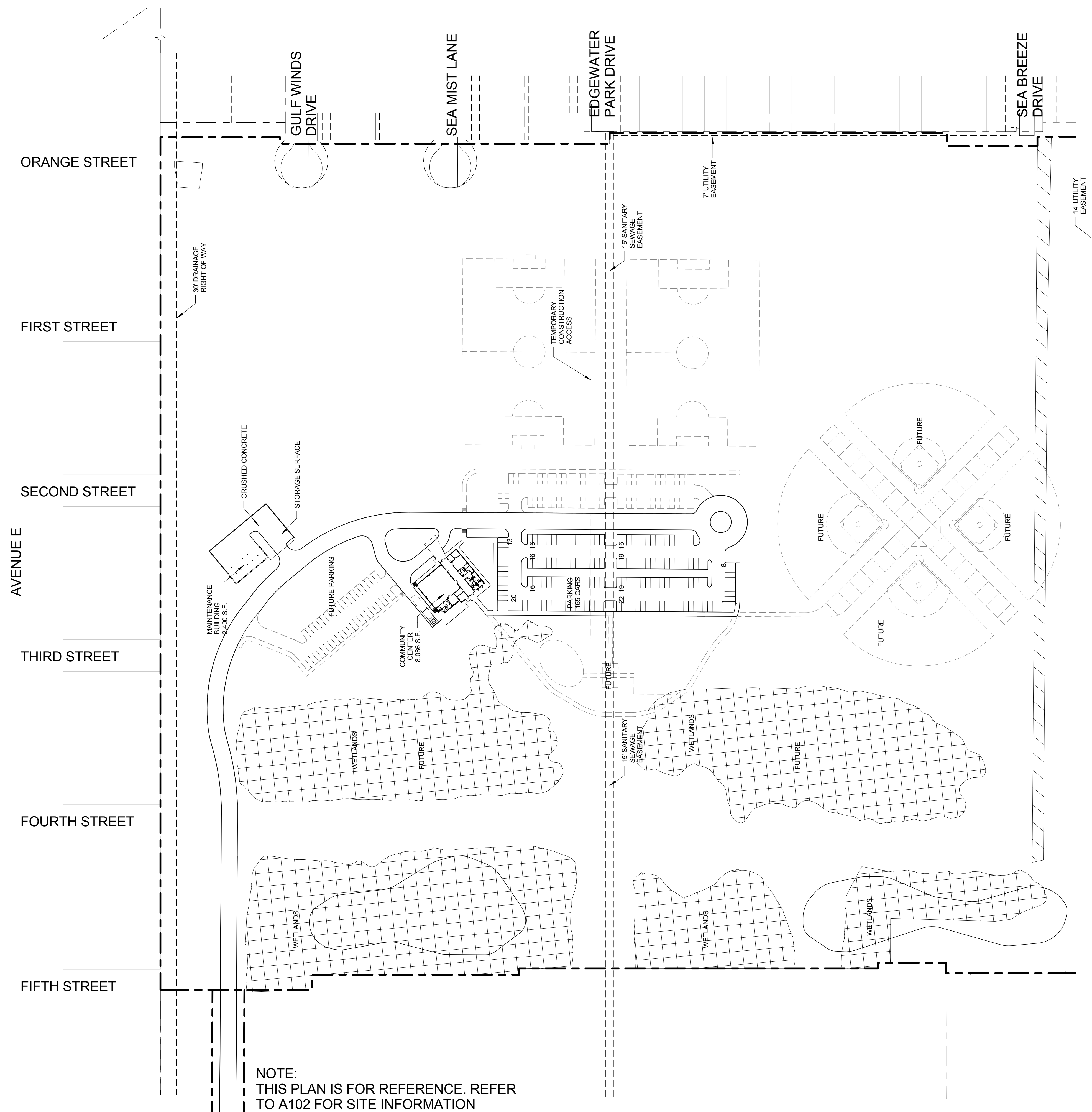

NOTE:
THIS PLAN IS FOR REFERENCE. REFER
TO A102 FOR SITE INFORMATION

NORTH
1 MASTER SITE PLAN
SCALE: 1" = 100'-0"

bdg
architecture
+ planning
boucher design group

Boucher Design Group LLC
Members A.I.A.
6802 Mapleridge, Suite 200
Bellaire, Texas 77401
Tel. 713.785.3644
www.bdgap.com

This document is an instrument of service protected by the copyright law of the United States of America, 17 U.S.C. §102, and shall not be copied or reproduced without the express written consent of Boucher Design Group, LLC. 2016

MARC E. BOUCHER
REGISTERED ARCHITECT
TEXAS NO. 14291
EXPIRES 5-31-16

BAYSIDE COMMUNITY CENTER
BACLIFF, TEXAS
GALVESTON COUNTY

DATE	02/16/16
PROJECT NO.	1409000
DRAWN BY	Author
CHECKED BY	Checker

MASTER SITE PLAN

A101
© COPYRIGHT 2016 BOUCHER DESIGN GROUP, LLC

ISSUE	DATE	DESCRIPTION
3	5/16/16	VALUE ENGINEERING

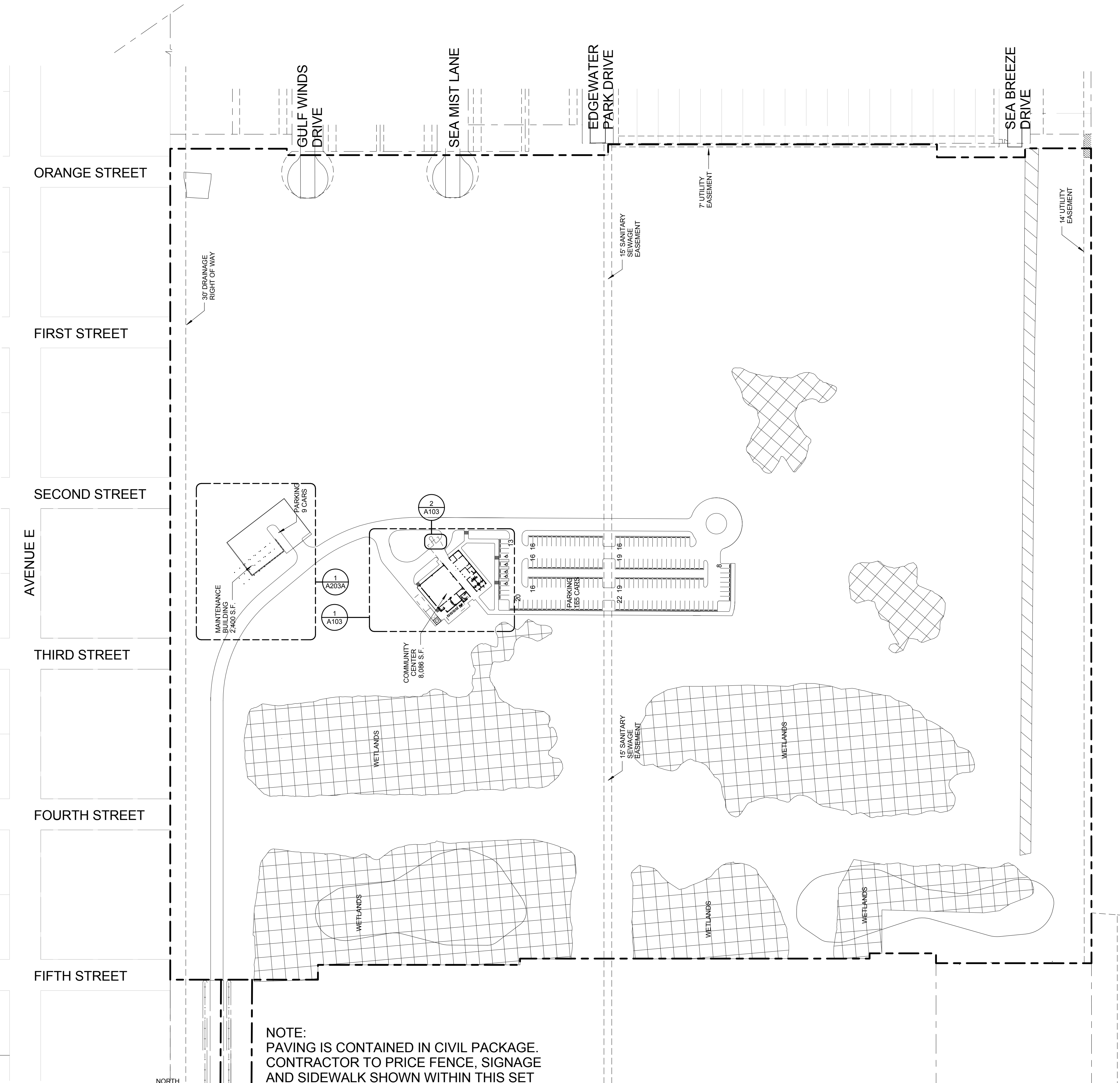

NOTE:
PAVING IS CONTAINED IN CIVIL PACKAGE.
CONTRACTOR TO PRICE FENCE, SIGNAGE
AND SIDEWALK SHOWN WITHIN THIS SET

GENERAL SITE PLAN NOTES

- COMPLY WITH TEXAS DEPARTMENT OF HEALTH AND PUBLIC SAFETY SPECIFICATIONS, CITY OF FRISCO, OR TEXAS HIGHWAY DEPARTMENT STANDARDS FOR CONSTRUCTION OF ALL DRIVEWAYS IN STREET RIGHT-OF-WAY.
- SPECIAL CARE SHALL BE TAKEN WITH NEW CONSTRUCTION ALONG ADJACENT PROPERTY LINES. ADJACENT PROPERTY IS ALTERED ONLY AS SPECIFICALLY REQUIRED IN THESE DRAWINGS AND SPECIFICATIONS, AND RESTORED TO ORIGINAL CONDITION BY CONTRACTOR IF ANY DAMAGE OCCURS.
- REFER TO CIVIL, PLUMBING, AND ELECTRICAL DRAWINGS FOR ALL UTILITY SERVICES TO AND ON THE SITE.
- REPAIR ALL LANDSCAPING AND GRASS AREAS DAMAGED BY CONSTRUCTION. BACK-FILL WITH TOP SOIL AND GRASS PER LANDSCAPE SPECIFICATIONS.
- ACCESSIBLE PARKING SPACES AS SHOWN ON THE SITE PLAN ARE EXISTING AND ARE DESIGNATED BY ABOVE GRADE SIGN AT EACH SPACE PER STATE AND LOCAL APPLICABLE CODES AND STANDARDS. MANEUVERING SPACE BETWEEN EACH TO HAVE 4" WIDE PAINTED WHITE STRIPES AT 12" O.C. PROVIDE CONCRETE RAMP AT WALKS AS DESIGNATED ON PLANS.
- SLOPE ACCESSIBLE RAMPS AT 1:12 MAXIMUM. REFER TO PLANS. SCORE RAMP SURFACE AT 3" O.C. PROVIDE NONSKID FINISH ACCESSIBLE AND DELIVERY RAMPS.
- SIDEWALKS ARE MIN. 4 1/2" THICK WITH 6" x 6" W2.9/W2.9 WELDED WIRE FABRIC TYPICAL.
- PROVIDE BONDING AGENT EQUAL TO EVAPOX BONDER #1 OR #2 AND BONDER #11 BY EPOXY INDUSTRIES INC. TO BOND CURBS TO PAVING PER MANUFACTURER'S INSTRUCTIONS.
- CONFORM TO THE REQUIREMENTS IN THE CIVIL DRAWINGS RELATED TO THE "POLLUTION PROTECTION PLAN" AND THE EPA'S NATIONAL POLLUTANT DISCHARGE ELIMINATION SYSTEM.
- OBTAIN AND PAY FOR ALL PERMITS NECESSARY TO PERFORM DEMOLITION WORK WITHIN THE PROPERTY LINE AND IN THE STREET RIGHT-OF-WAY.
- COORDINATE WITH THE LOCAL UTILITY COMPANIES FOR THE DISCONNECTION AND PLUGGING OF PUBLIC UTILITIES SERVING STRUCTURES TO BE DEMOLISHED, AND UTILITIES TO BE ABANDONED.
- ARRANGE AND PAY FOR RELOCATION OF POWER POLES AND UTILITIES REQUIRING DEMOLITION IN ORDER TO PERFORM NEW CONSTRUCTION.
- DAMAGE TO EXISTING SITE OR SURROUNDING IMPROVEMENTS, PUBLIC OR PRIVATE, BY CONTRACTOR ARE TO BE REPAIRED OR REPLACED AT THE CONTRACTOR'S EXPENSE.
- PUMP OPEN TRENCHES AT PERIMETER OR EXISTING PAVING OR AROUND NEW CONSTRUCTION FREE OF STANDING WATER AT ALL TIMES.
- WHERE EXISTING CONCRETE CURB IS TO BE REMOVED SAW CUT EXISTING CURB 1-1/2 INCHES DEEP MIN. AND REMOVE TWO FEET OF EXISTING PAVING FOR NEW CONNECTION.
- UNLESS OTHERWISE NOTED PERIMETER LANDSCAPING ABUTTING CURBS ARE FINE GRADED TO TOP OF CURB. PROVIDE FERTILE, FRIABLE, SANDY LOAM FILL TO TOP OF CONCRETE CURB AT ALL AREAS.
- ALL PARKING STRIPES ARE TO BE PAINTED WHITE.
- PLACE SIDE WALK CONTROL JOINTS AND EXPANSION JOINTS PER DETAIL. CONTRACTOR TO SUBMIT PROPOSED JOINT LAYOUT TO ARCHITECT FOR APPROVAL PRIOR TO LAYOUT IN THE FIELD.

PIPE SLEEVE NOTES

- REFER TO PLUMBING OR ELECTRICAL DRAWINGS FOR SPECIFIC INFORMATION AND RELATED DETAILS FOR ALL GAS, POWER, TELEPHONE AND CABLE SLEEVES.
- PIPES INDICATED AS "ELEC. PVC" ARE FOR FUTURE USE AND ARE 24" BELOW GRADE AND CAPPED. PROVIDE IRON PINS AT EACH END TO MARK LOCATIONS. INSTALL PULL WIRES INSIDE ELEC. PVC SLEEVES.



Boucher Design Group LLC
Members A.I.A.
6802 Mapleridge, Suite 200
Bellaire, Texas 77401
Tel. 713.785.3644
www.bdg.com

This document is an instrument of service protected by the copyright law of the United States of America, 17 U.S.C §102, and shall not be copied or reproduced without the express written consent of Boucher Design Group, LLC. 2016

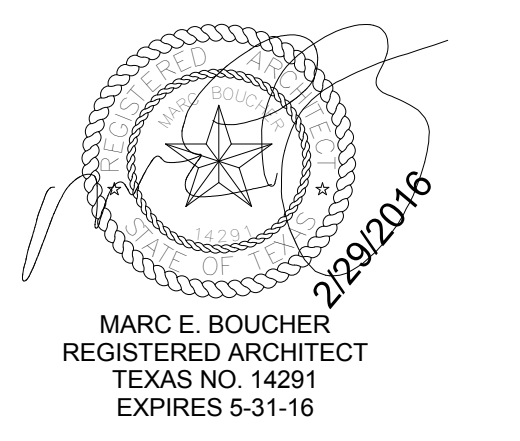

BAYSIDE COMMUNITY CENTER

BACLIFF, TEXAS
GALVESTON COUNTY

DATE	12/08/2015
PROJECT NO.	1409000
DRAWN BY	BW
CHECKED BY	BA

SITE PLAN

A102

ISSUE	DATE	DESCRIPTION
3	5/16/16	VALUE ENGINEERING

2 | SIDEWALK PLAN @ FLAGPOLE
SCALE: 1/8" = 1'-0"

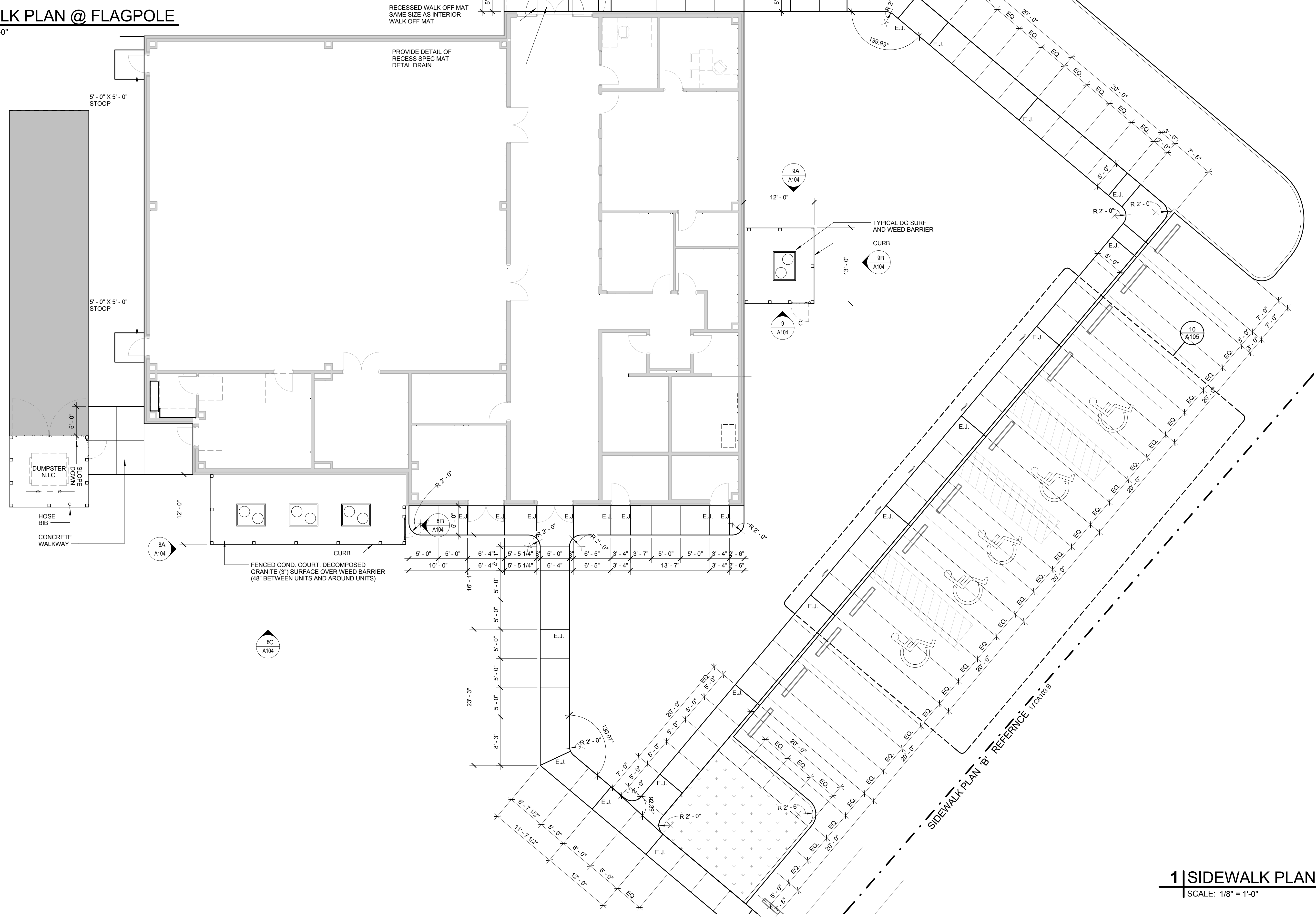
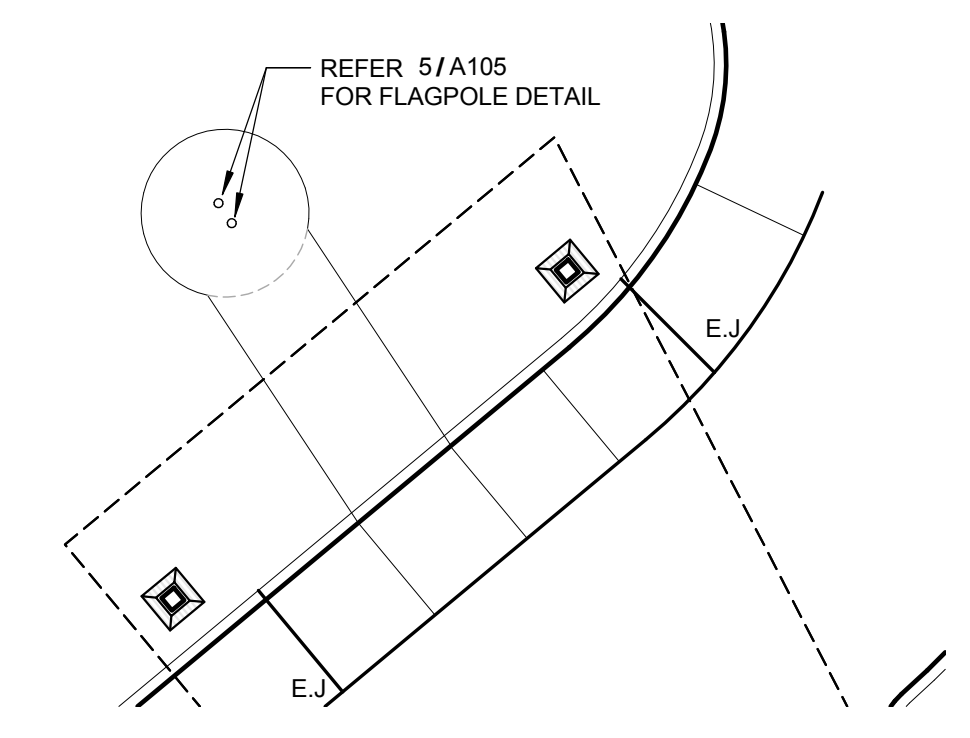

Boucher Design Group LLC
Members A.I.A.
6802 Mapleridge, Suite 200
Bellaire, Texas 77401
Tel. 713.785.3644
www.bdgap.com

This document is an instrument of service protected by the copyright law of the United States of America, 17 U.S.C §102, and shall not be copied or reproduced without the express written consent of Boucher Design Group, LLC. 2016

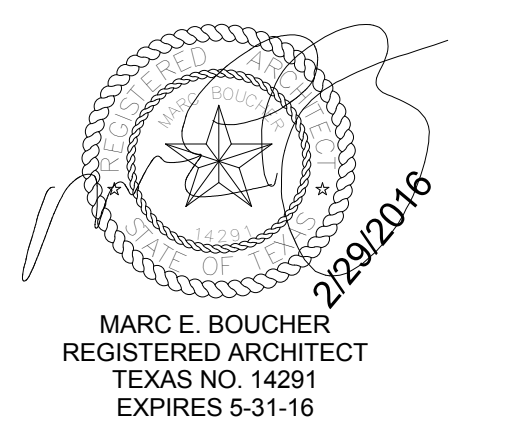

BAYSIDE COMMUNITY CENTER

BACLIFF, TEXAS

GALVESTON COUNTY

DATE	02/29/16
PROJECT NO.	1409000
DRAWN BY	Author
CHECKED BY	Checker

SIDEWALK PLAN

1 | SIDEWALK PLAN - A
SCALE: 1/8" = 1'-0"

A103
© COPYRIGHT 2016 BOUCHER DESIGN GROUP, LLC

ISSUE	DATE	DESCRIPTION
3	5/16/16	VALUE ENGINEERING

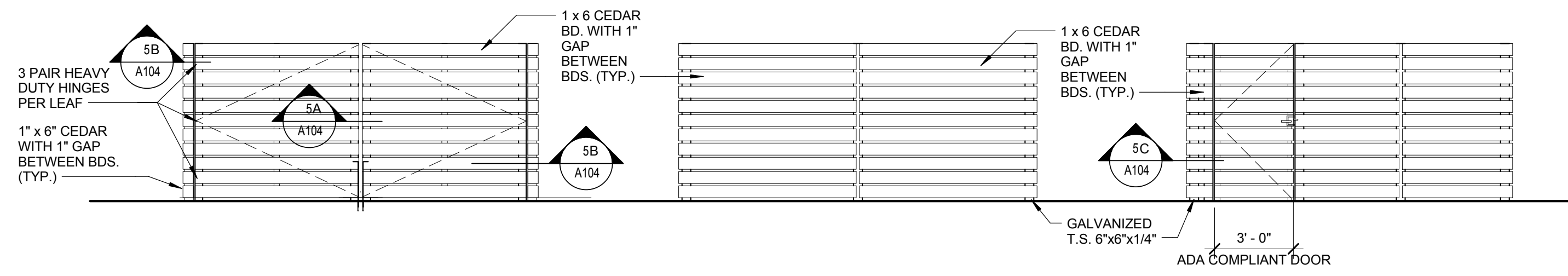

7 | DUMPSTER ELEVATIONS

SCALE: 1/4" = 1'-0"

10 | DUMPSTER WALL SECTION Copy 1

SCALE: 1/2" = 1'-0"

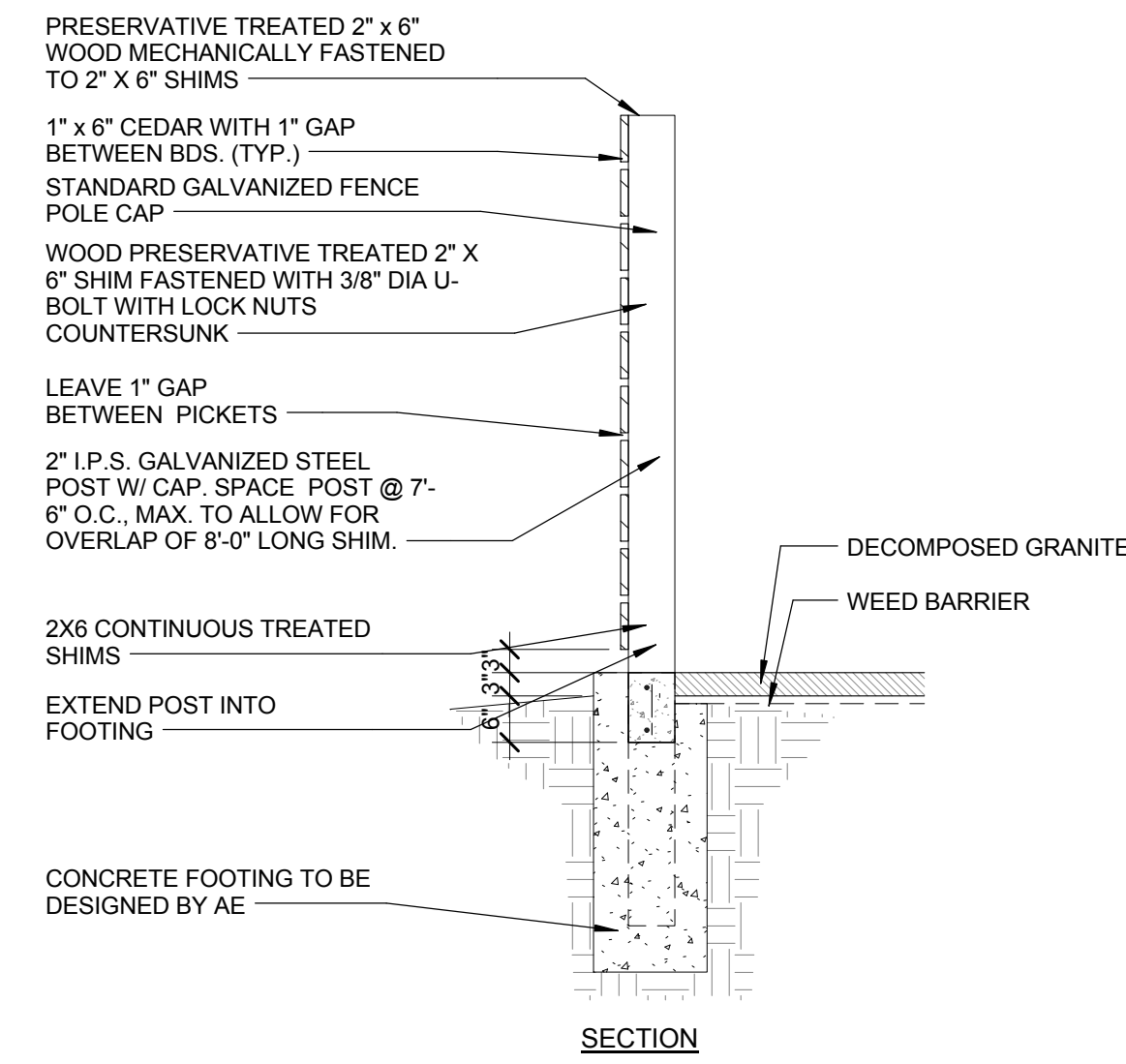

6 | DUMPSTER DIMENSION PLAN

SCALE: 1/4" = 1'-0"

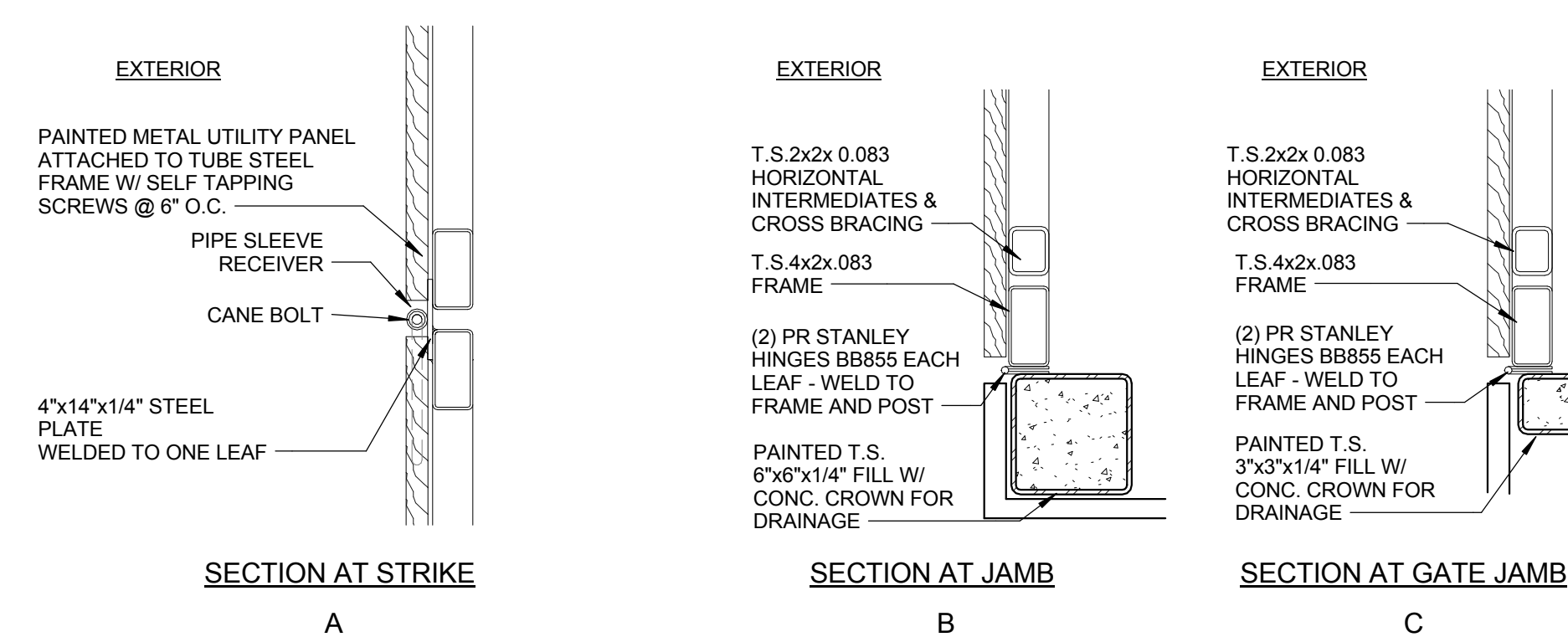
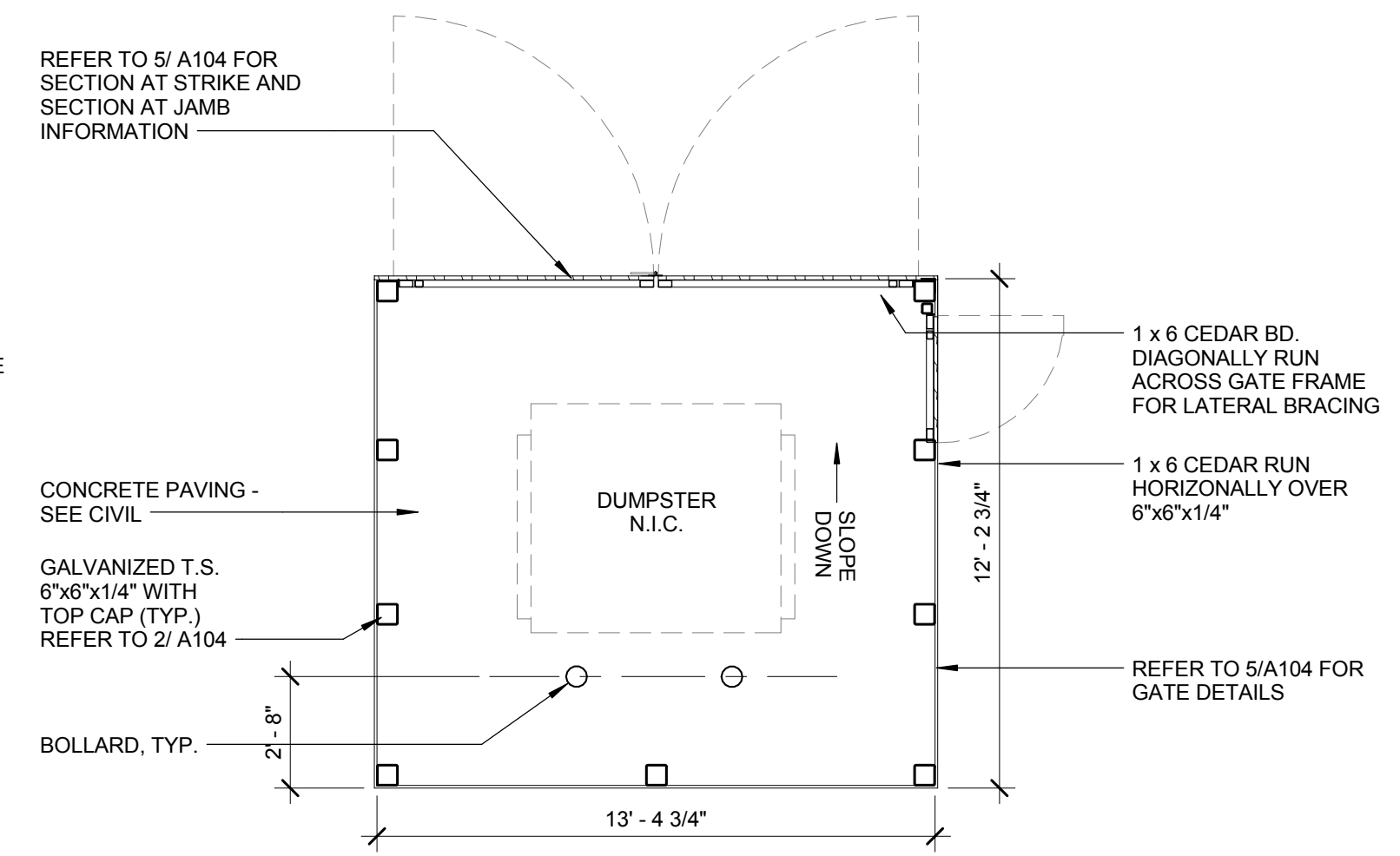

5 | GATE DETAILS

SCALE: 1 1/2" = 1'-0"

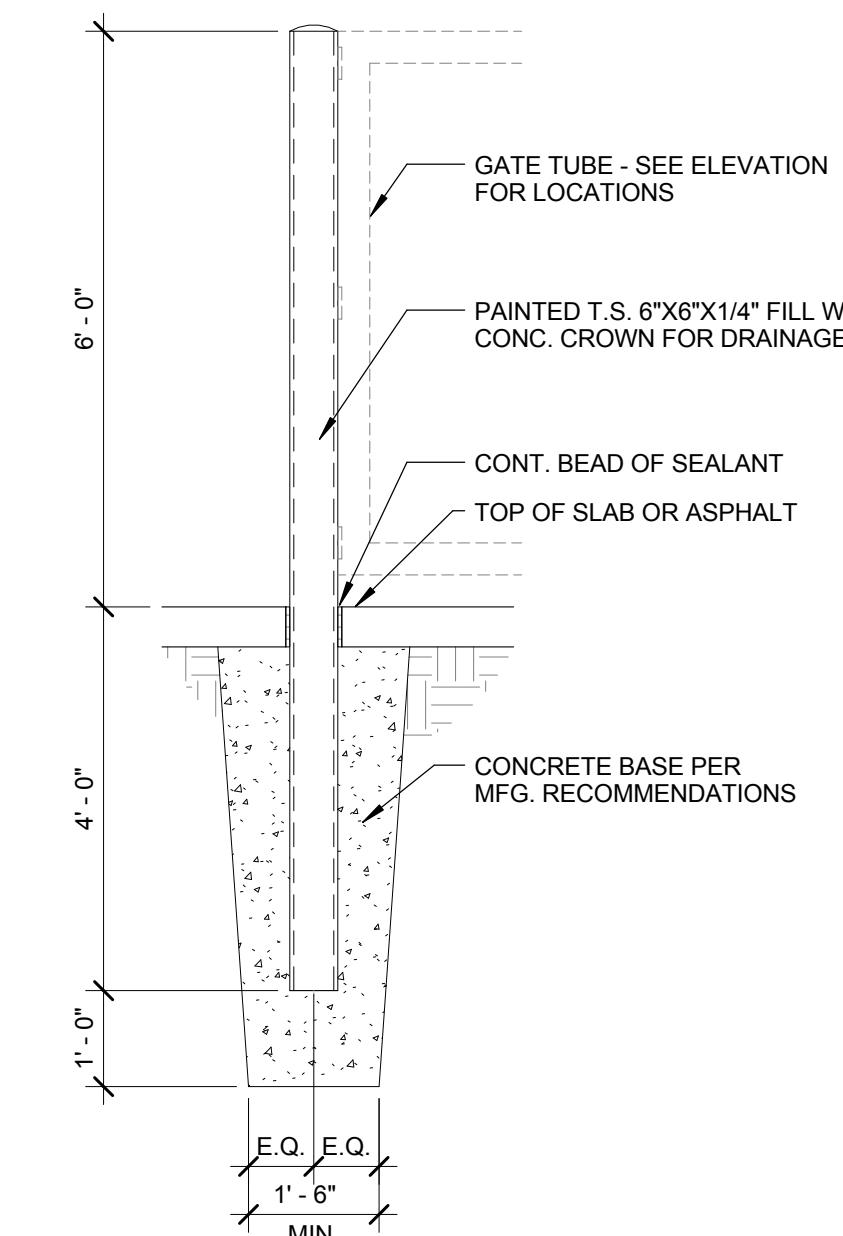

4 | TYPICAL GATE COLUMN

SCALE: 1/2" = 1'-0"

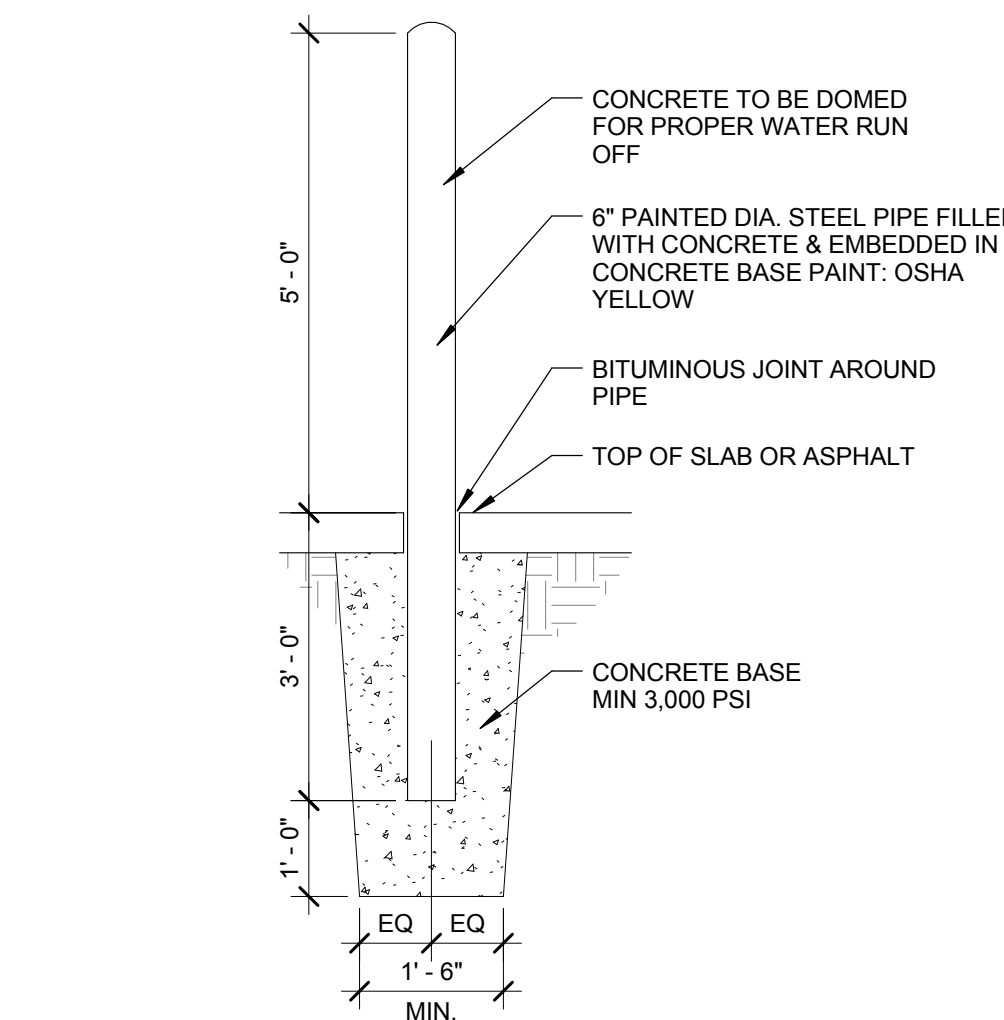

3 | TYPICAL BOLLARD DETAIL

SCALE: 1/2" = 1'-0"

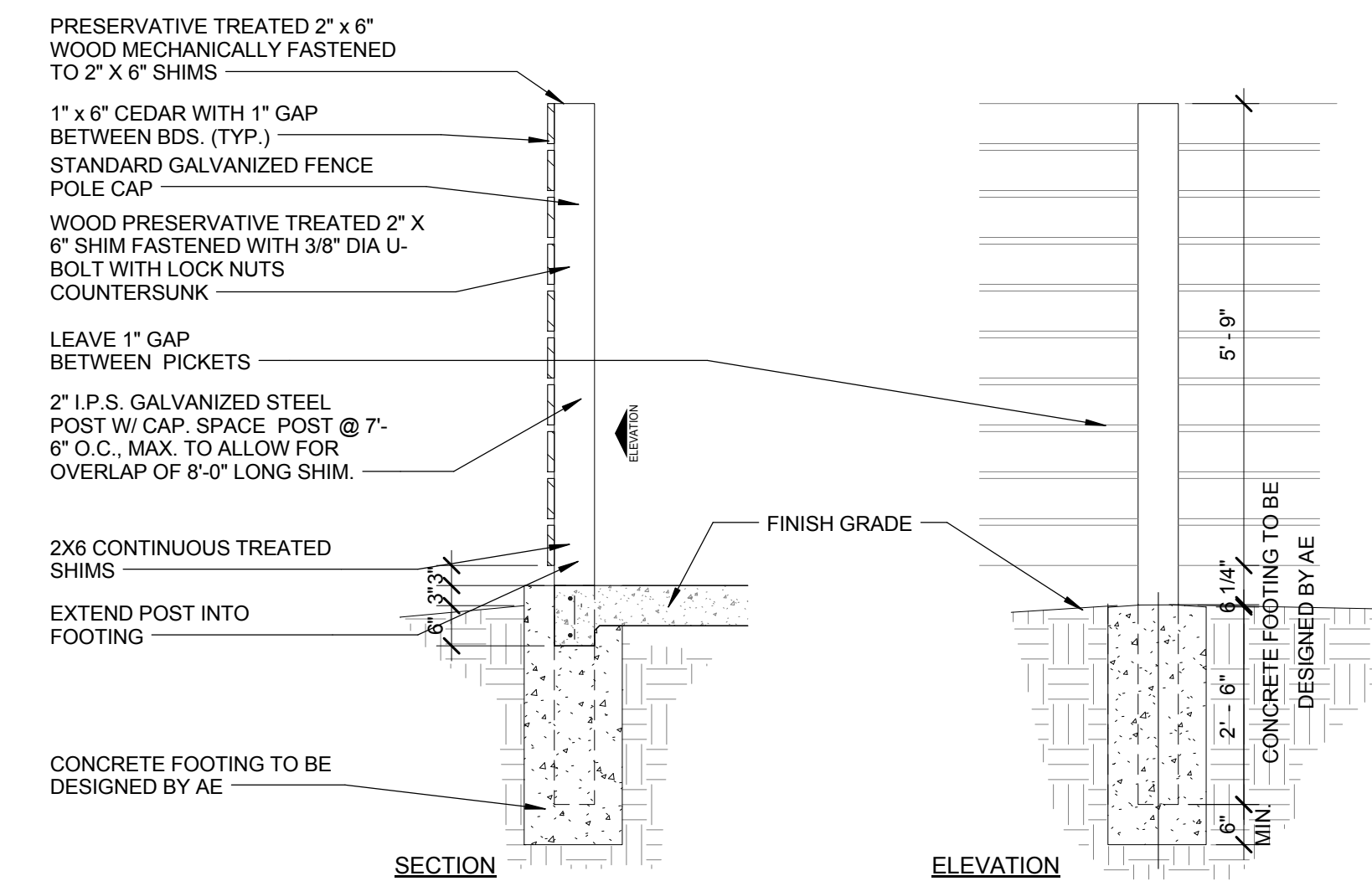

2 | DUMPSTER WALL SECTION

SCALE: 1/2" = 1'-0"

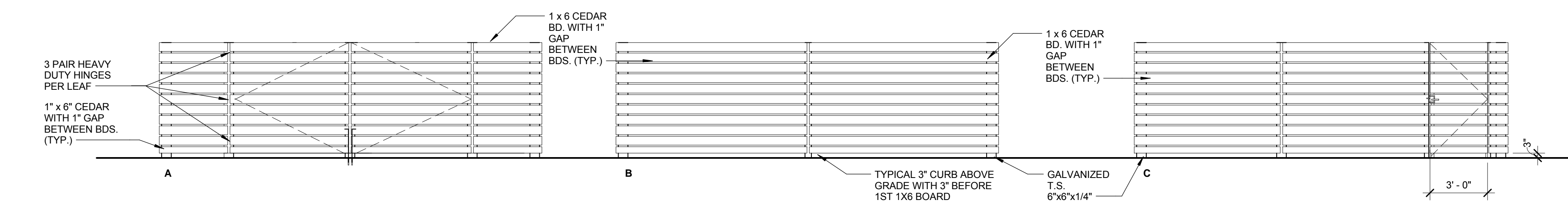

8 | ELEVATIONS

SCALE: 1/4" = 1'-0"

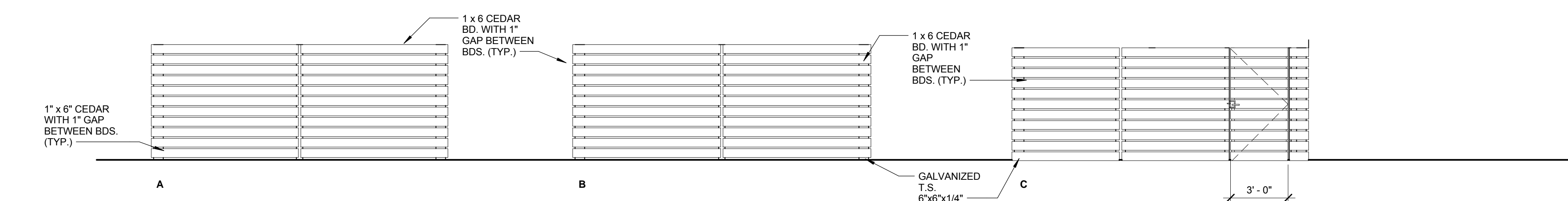

9 | ELEVATIONS

SCALE: 1/4" = 1'-0"

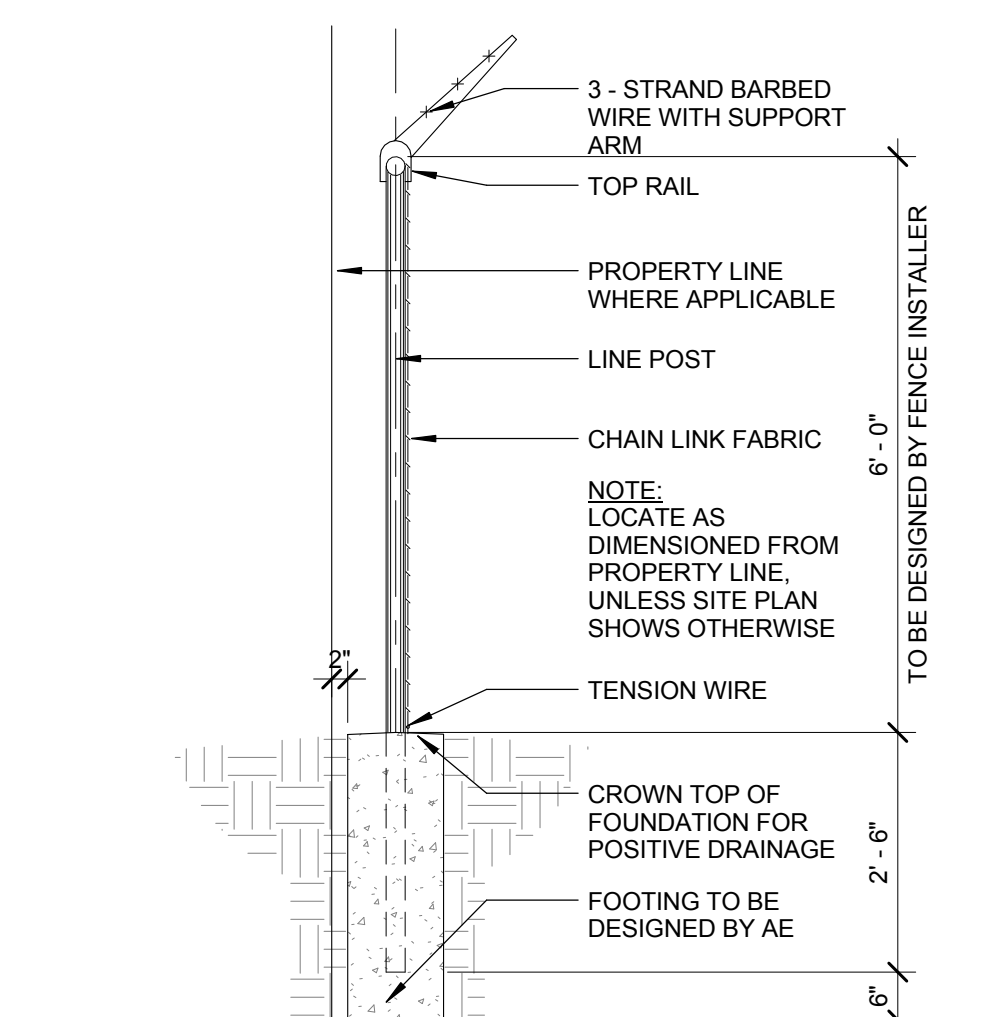

1 | CHAIN LINK FENCE SECTION

SCALE: 1/2" = 1'-0"



Boucher Design Group LLC
Members A.I.A.
6802 Maple Ridge, Suite 200
Bellaire, Texas 77401
Tel. 713.785.3644
www.bdgap.com

This document is an instrument of service protected by the copyright law of the United States of America, 17 U.S.C §102, and shall not be copied or reproduced without the express written consent of Boucher Design Group, LLC. 2016

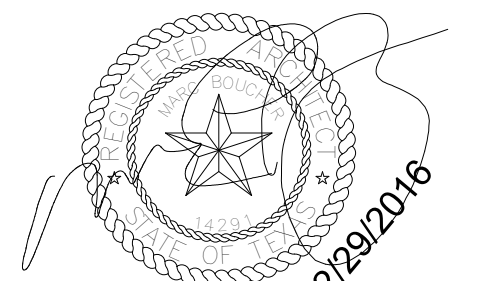

MARC E. BOUCHER
REGISTERED ARCHITECT
TEXAS NO. 14291
EXPIRES 5-31-16

BAYSIDE COMMUNITY CENTER

BACLIFF, TEXAS

GALVESTON COUNTY

DATE	02/16/16
PROJECT NO.	1409000
DRAWN BY	Author
CHECKED BY	Checker

DUMPSTER /AC ENCLOSURE DETAILS

A104

© COPYRIGHT 2016 BOUCHER DESIGN GROUP, LLC

ISSUE	DATE	DESCRIPTION
3	5/16/16	VALUE ENGINEERING

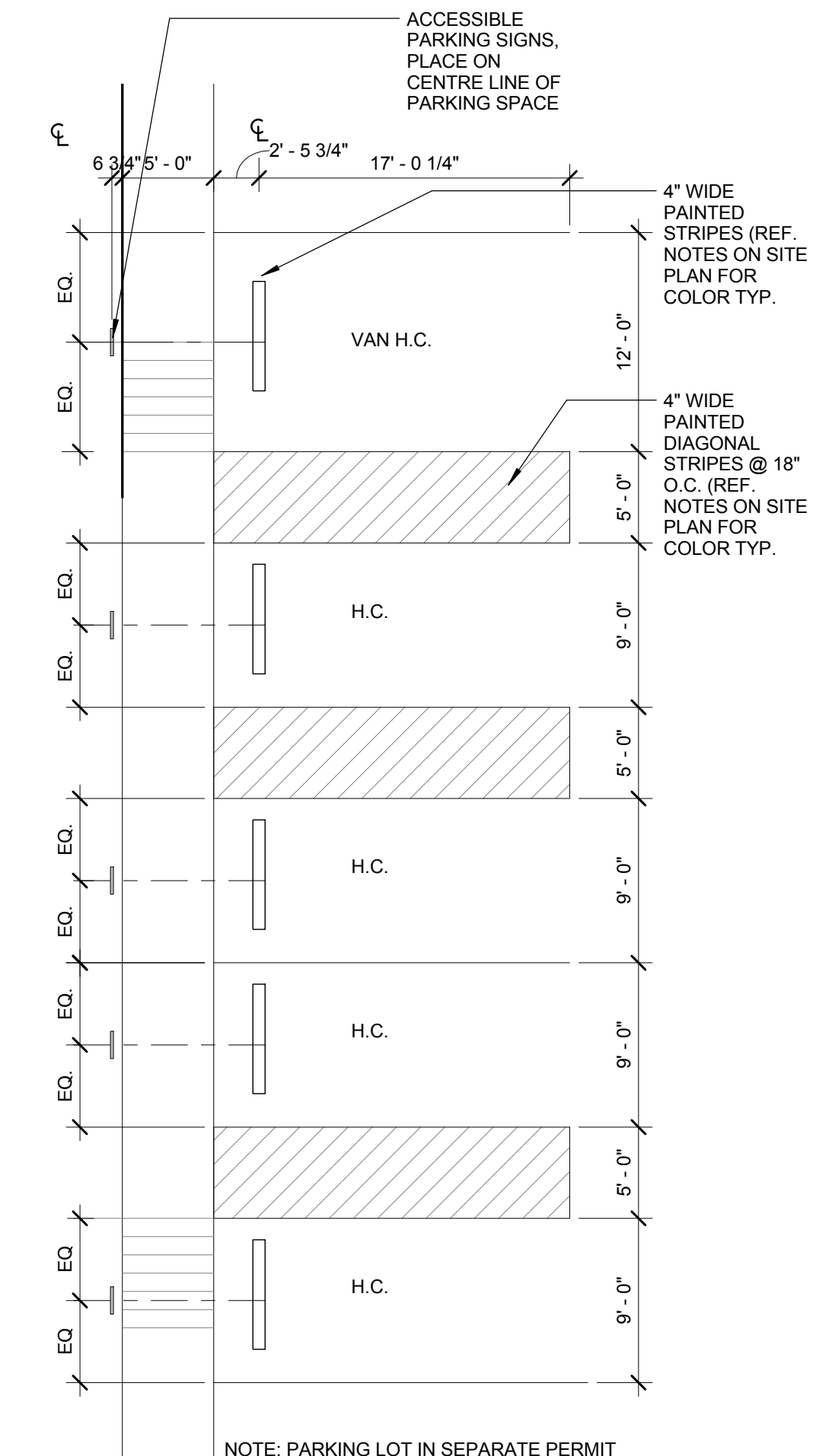

10 | TYPICAL ACCESSIBLE PARKING
SCALE: 1/8" = 1'-0"

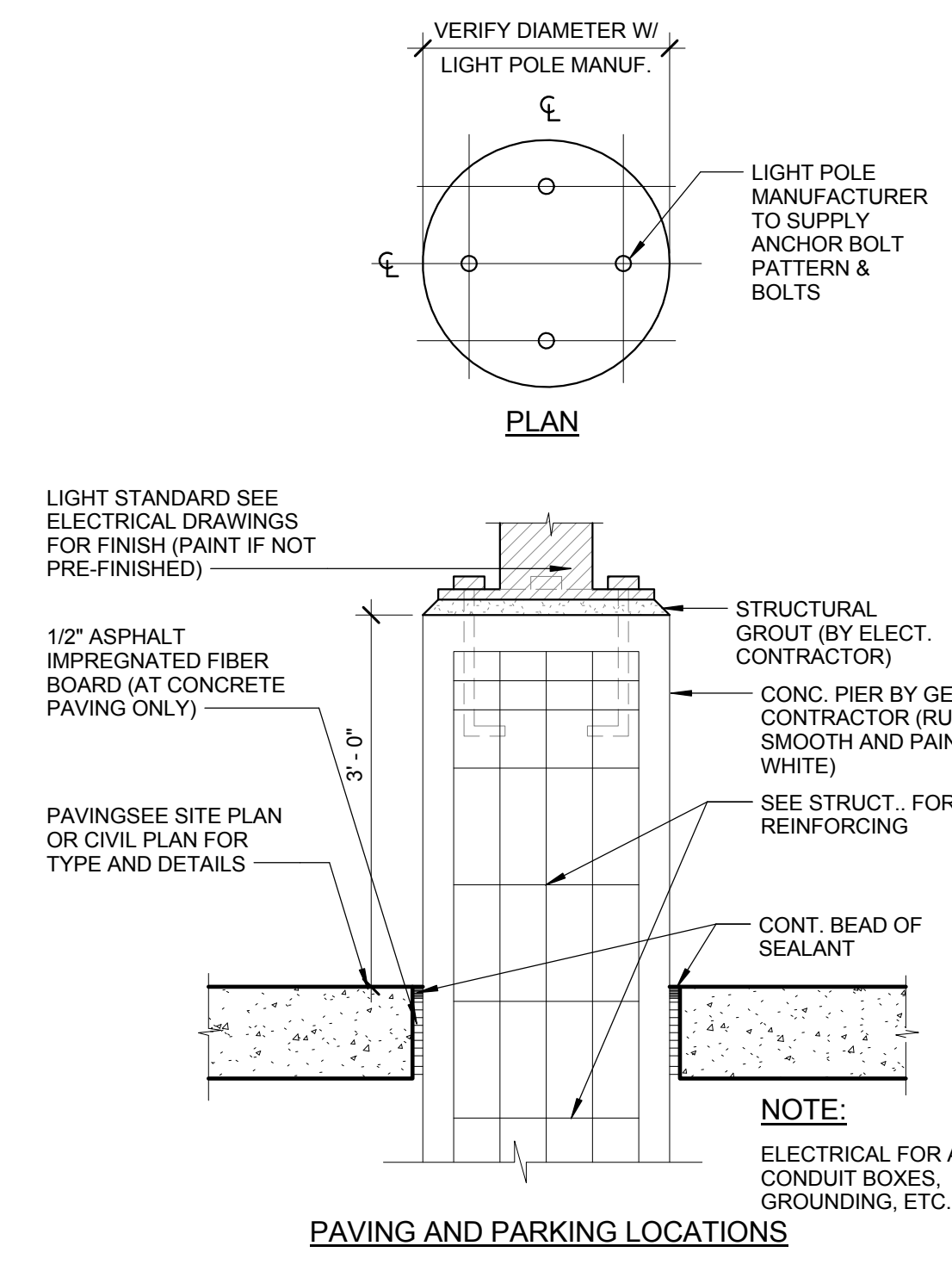

7 | SITE LIGHTING BASE
SCALE: 3/4" = 1'-0"

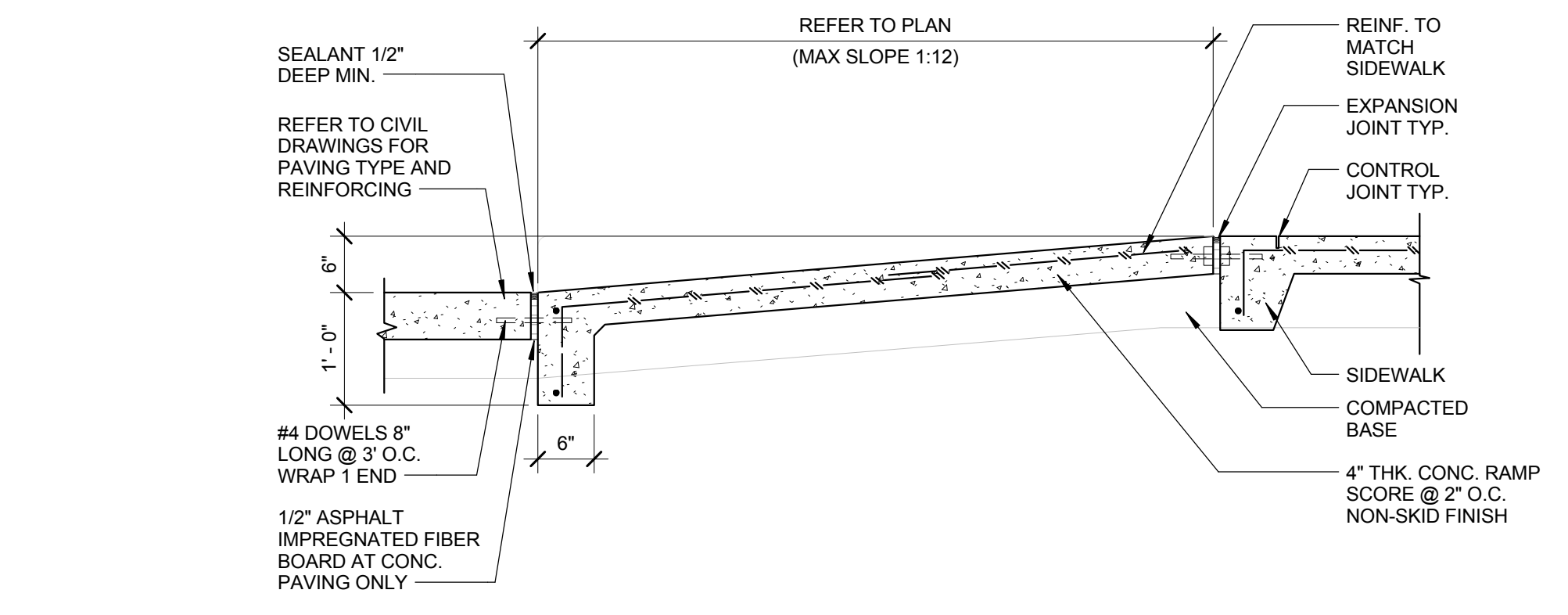

4 | ACCESSIBLE/ SERVICE RAMP SECTION
SCALE: 3/4" = 1'-0"

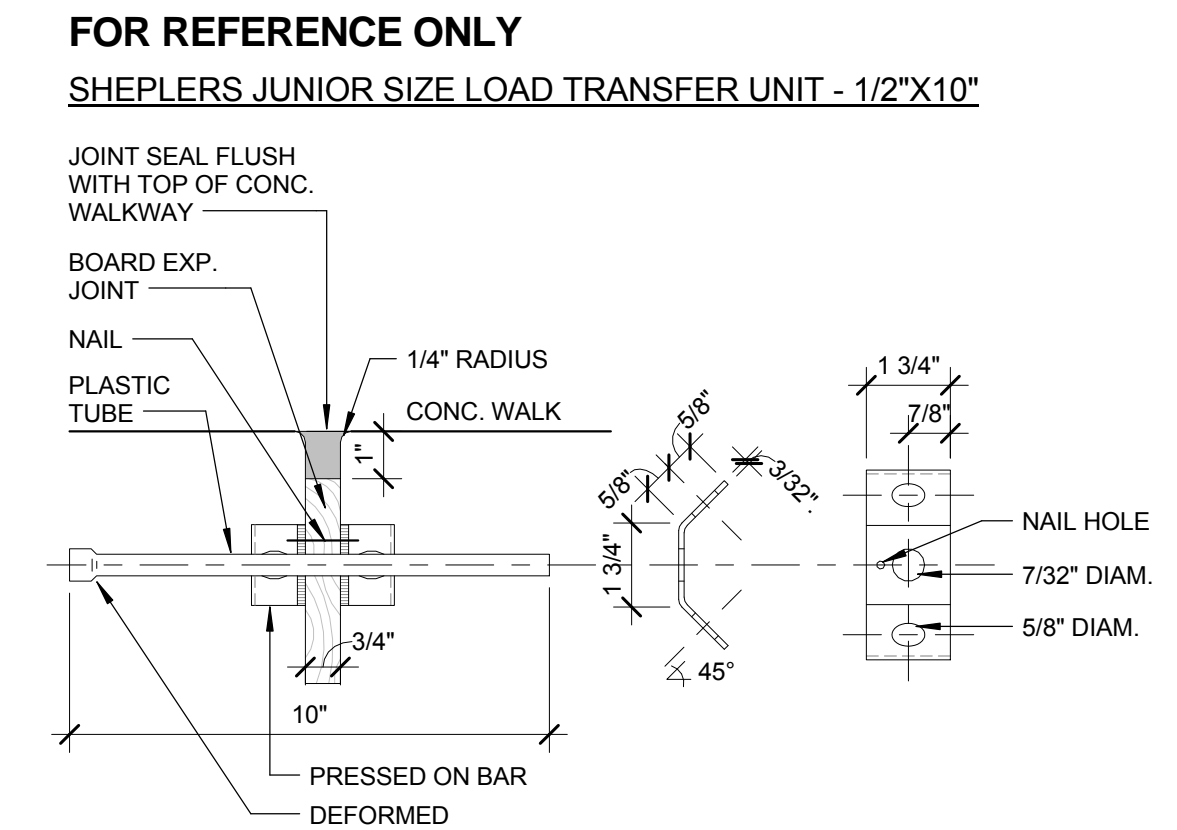
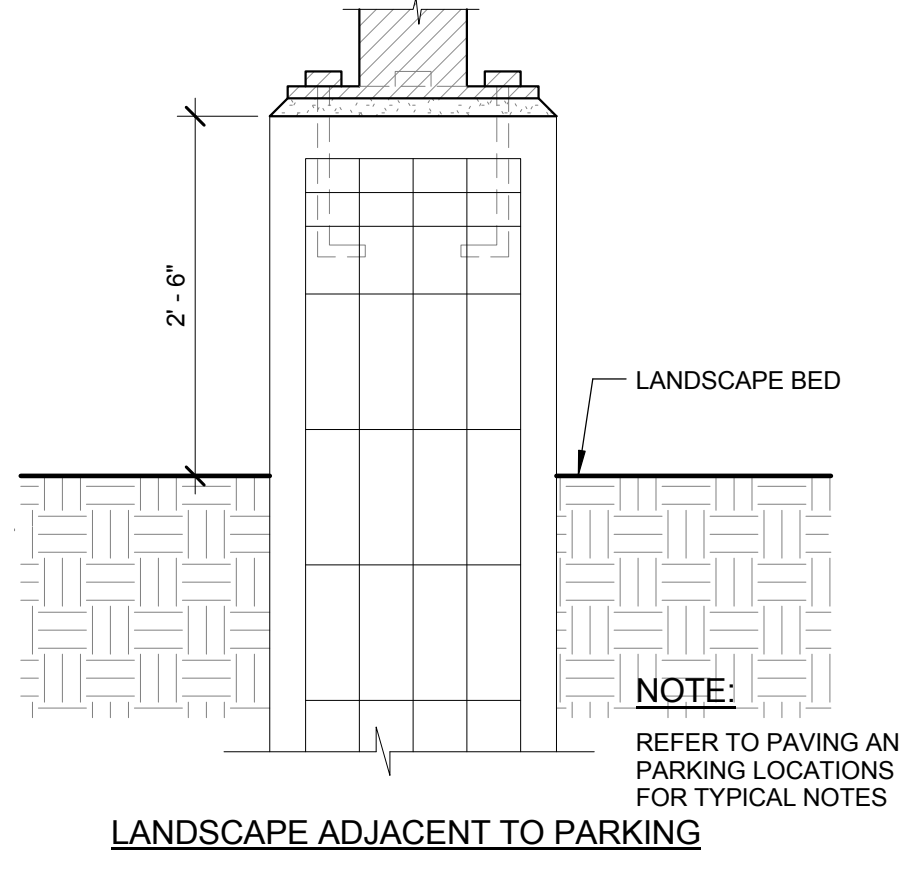

3 | LOAD TRANSFER UNIT DETAIL
SCALE: 3" = 1'-0"

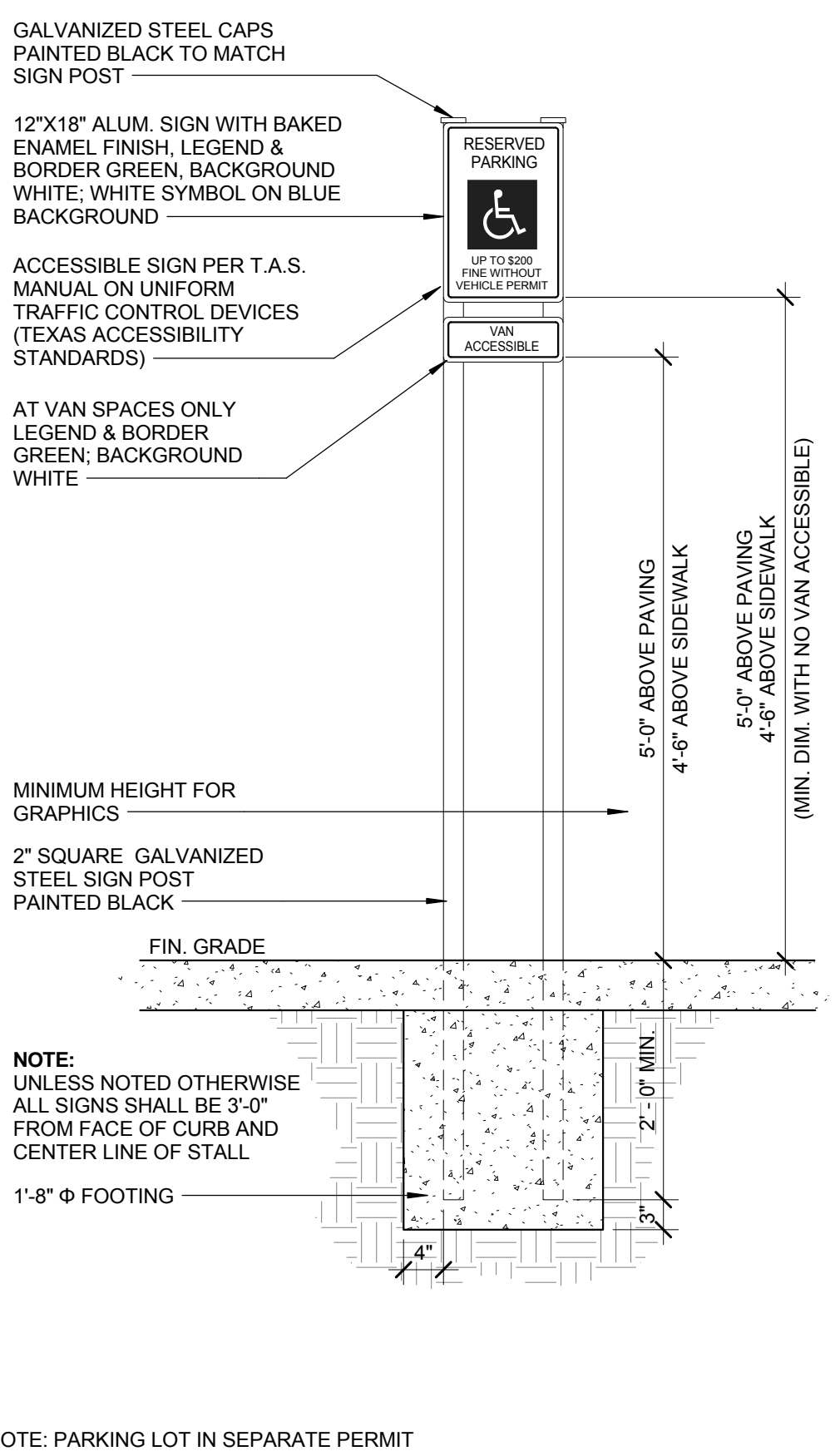

9 | TYPICAL PARKING SIGN DETAIL
SCALE: 3/4" = 1'-0"

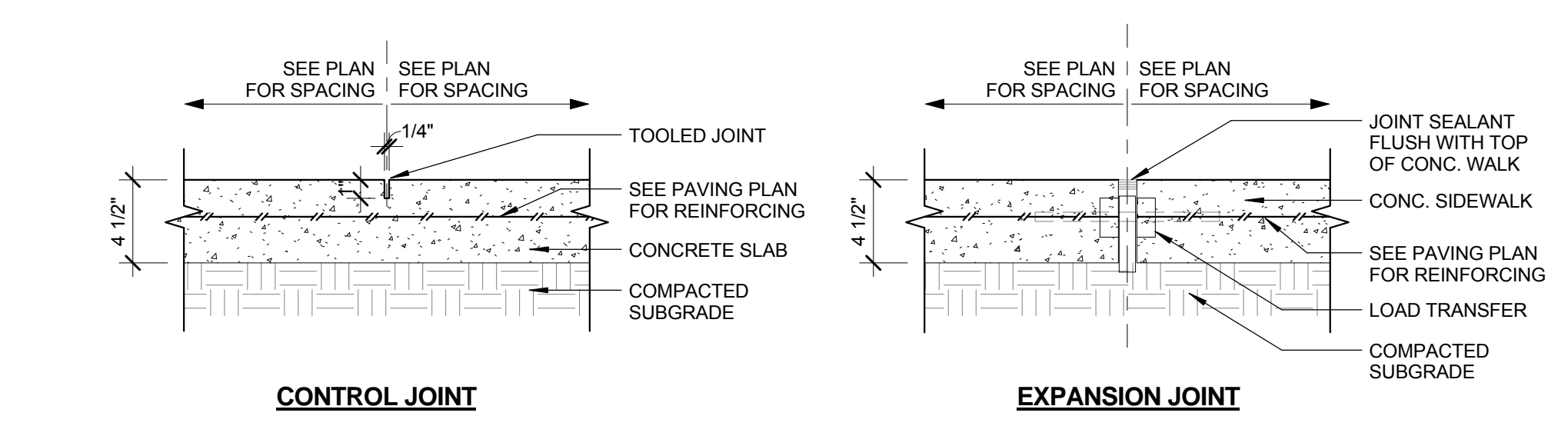

6 | TYPICAL CONCRETE DETAILS
SCALE: 1 1/2" = 1'-0"

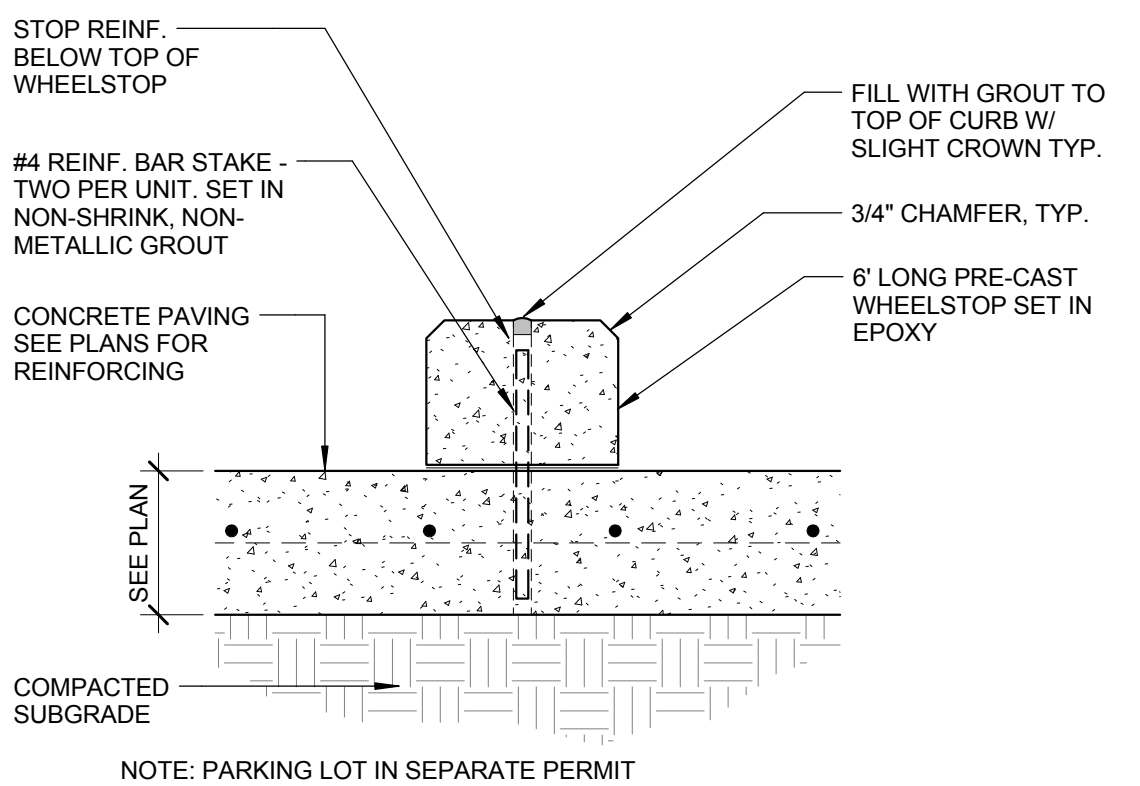

8 | TYPICAL WHEELSTOP DETAIL
SCALE: 1 1/2" = 1'-0"

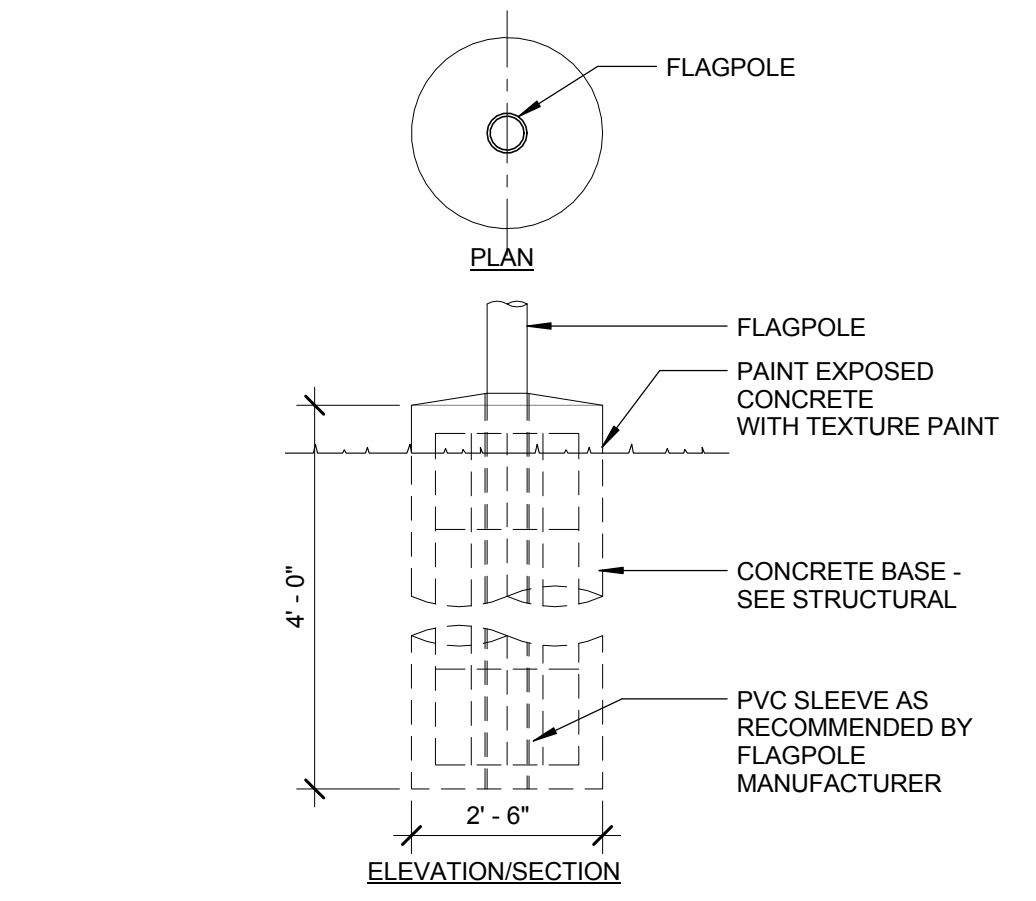

5 | FLAGPOLE DETAIL
SCALE: 1/2" = 1'-0"

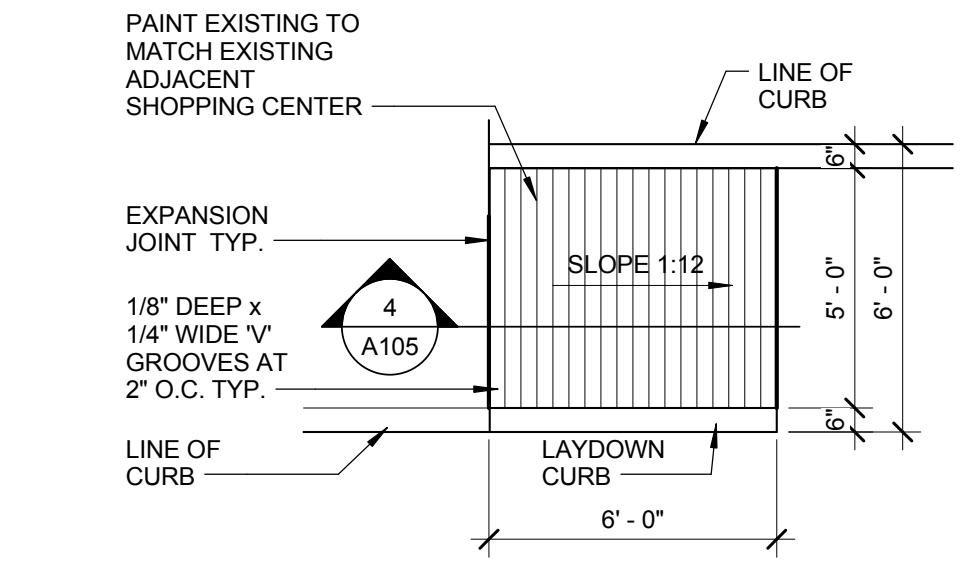

2 | ACCESSIBLE RAMP
SCALE: 1/4" = 1'-0"

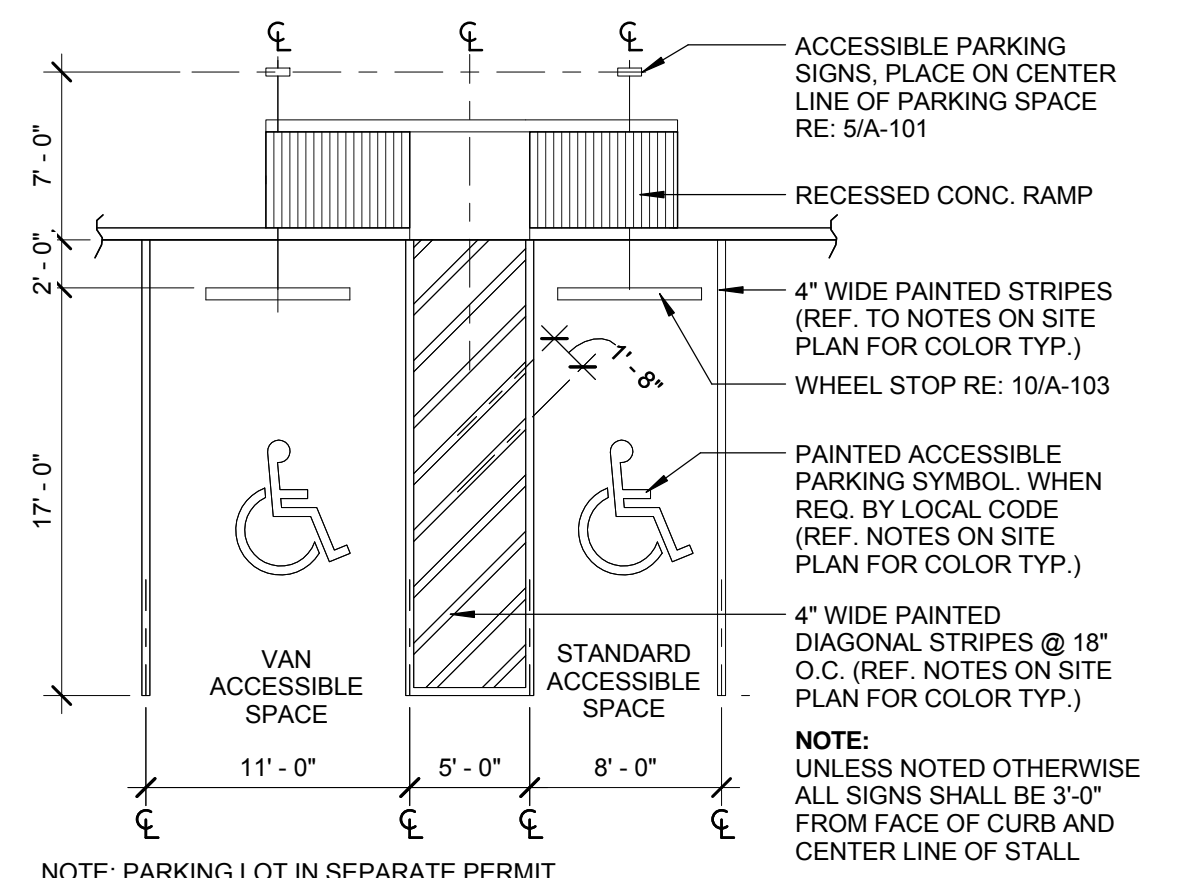

1 | TYPICAL LOT IN VAN ACCESSIBLE PARKING
SCALE: 1/8" = 1'-0"



Boucher Design Group LLC
Members A.I.A.
6802 Maple Ridge, Suite 200
Bellaire, Texas 77401
Tel. 713.785.3644
www.bdgap.com

This document is an instrument of service protected by the copyright law of the United States of America, 17 U.S.C §102, and shall not be copied or reproduced without the express written consent of Boucher Design Group, LLC. 2016

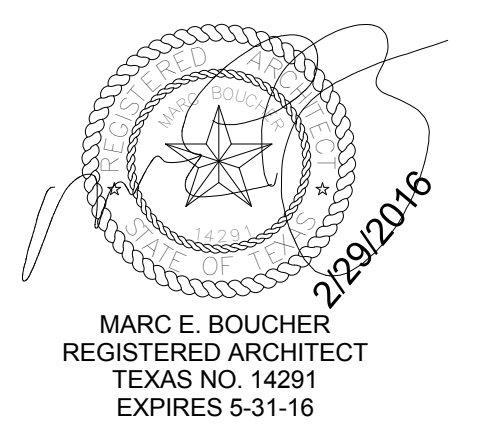

BAYSIDE COMMUNITY CENTER
BACLIFF, TEXAS
GALVESTON COUNTY

DATE	02/16/16
PROJECT NO.	1409000
DRAWN BY	Author
CHECKED BY	Checker

SITE DETAILS

A105
COPYRIGHT 2016 BOUCHER DESIGN GROUP, LLC

C:\Users\stian\Documents\REVIT PROJECTS\1409000_GALVESTON COMMUNITY CENTER_brian.rvt 6/9/2016 10:29:20 AM

ALL WOOD FRAMING AND PLYWOOD SHALL BE NON-COMB/FIRE-RETARDANT AS PER CODE

DO NOT SCALE THESE DRAWINGS FOR DIMENSIONAL INFORMATION. REFER TO DIMENSIONS ON THE FLOOR PLAN AND THE ENLARGED PLANS. IF THERE IS A CONFLICT WITH THE PLAN DIMENSIONS OR AN EXISTING FIELD CONDITION CONTACT THE ARCHITECT.

METAL STUD NOTE:

ALL LIGHT GAUGE STEEL STUDS IN THE INTERIOR WALLS SHALL BE SIZED IN ACCORDANCE WITH THE STUD MANUFACTURER'S RECOMMENDATIONS FOR STUD SIZE, SPACE AND UNBRACED LENGTH OF STUDS. ALL STEEL STUDS SHALL BE MANUFACTURED FROM PRIME STANDARD COMMERCIAL QUALITY STEEL SHEET HAVING A YIELD STRENGTH OF 33,000 POUNDS PER SQUARE INCH (PSI). THE STRUCTURAL PROPERTIES SHALL BE COMPUTED IN ACCORDANCE WITH THE AMERICAN IRON AND STEEL INSTITUTE LATEST EDITION OF "SPECIFICATION FOR THE DESIGN OF LIGHT GAUGE COLD-ROLLED STEEL STRUCTURAL MEMBERS".

GENERAL NOTES

- DO NOT SCALE DRAWINGS
- DIMENSIONS ARE FROM FACE OF FINISHED WALL TO FACE OF FINISHED WALL UNLESS NOTED OTHERWISE. (U.N.O.)
- IT IS THE RESPONSIBILITY OF THE GENERAL CONTRACTOR TO CROSS-CHECK THE STRUCTURAL AND ELECTRICAL DRAWINGS WITH THE ARCHITECTURAL DRAWINGS PRIOR TO THE ORDERING / INSTALLATION OF STEEL AND ELECTRICAL WORK. ANY DISCREPANCIES BETWEEN THE ARCHITECTURAL AND STRUCTURAL AND ELECTRICAL DRAWINGS SHALL BE BROUGHT TO THE ARCHITECT'S ATTENTION FOR IMMEDIATE CLARIFICATION.
- ALL CONSTRUCTION SHALL COMPLY WITH ALL APPLICABLE STATE, CITY AND LOCAL CODES AND ORDINANCES IN THE LOCATION OF THE PROJECT.
- WHERE EXISTING CONDITIONS ARE CUT OR DISTURBED TO PERMIT INSTALLATION OF NEW WORK, MATCH AND PATCH EXISTING DISTURBED CONSTRUCTION TO ORIGINAL CONDITION UNLESS OTHERWISE NOTED.
- ALL MATERIALS NOT LABELED ARE TYPICAL FOR ALL SIMILAR LOCATIONS. QUESTIONS SHALL BE REFERRED TO THE ARCHITECT.
- WHERE REQUIRED BY CODE, ALUMINUM VERTICAL MULLIONS SHALL RECEIVE STEEL STIFFENERS TO ACHIEVE MINIMUM REQUIREMENTS TO CONFORM WITH THE WIND SPEED CRITERIA. 1/4" THICK GLASS AND SHALL HAVE A MAXIMUM SIZE OF 43 SQUARE FEET.
- COORDINATE ALL REQUIRED ELECTRICAL CONDUITS AND SLEEVES WITH MECHANICAL AND ELECTRICAL DRAWINGS FOR IRRIGATION UNDER SIDEWALK AREAS, AT DECORATIVE LIGHT POLES, AND AT PLANTERS.
- REFER TO BUILDING ELEVATION DRAWINGS FOR FINISH MATERIAL CALLOUTS AND PAINT REQUIREMENTS.
- REFER TO ROOF PLANS FOR DOWNSPOUT SIZES AND GAUGES.
- SIDEWALKS SHALL BE MINIMUM 4-1/2" THICK CONCRETE WITH 6"x6" x 2,825 W.W.J. REINFORCEMENT. PROVIDE FILLER STRIP AND SEALANT IN JOINTS BETWEEN PAVERS AND ADJACENT CONCRETE PER DETAILS.
- PROVIDE 15 MIL VAPOR BARRIER UNDER ALL FLOOR SLABS, AND LEVEL FILL PER SPECIFICATIONS.
- PROVIDE 5/8" THICK GYPSUM BOARD THROUGHOUT THE PROJECT, UNLESS NOTED OTHERWISE (TYPE 'X' IF REQUIRED).
- PROVIDE WATER RESISTANT GYPSUM AT ALL WALLS IN RESTROOM AREAS
- SEE PLUMBING DRAWINGS FOR ADDITIONAL INFORMATION REGARDING FLOOR DRAINS, FLOOR SINKS, CLEANOUTS, ETC.
- DIMENSIONS ARE TO FACE OF STUDS, STRIPPING, FACE OF EXTERIOR WALL OR CENTERLINE OF COLUMN, AS INDICATED.
- SEAL PARTITIONS EXTENDING TO DECK, ON EACH SIDE.
- OPENINGS REQUIRED BY MECHANICAL AND ELECTRICAL APPARATUS WALLS IN EXPOSED AREAS SHALL BE SEALED AIR TIGHT.
- UNLESS OTHERWISE NOTED, WALLS ENCLOSING COLUMNS SHALL BE CENTERED ON COLUMN LINES.
- MAXIMUM CLEAR SPAN HEIGHTS FOR INTERIOR METAL STUDS SHALL BE SUCH THAT DEFLECTION UNDER A 5 P.S.F. LATERAL LOAD SHALL NOT EXCEED 1/800 LOAD AT CERAMIC TILE FINISHES AND 1/120 AT ALL OTHER AREAS.
- ALL WALLS ARE TO STEEL DECK UNLESS OTHERWISE NOTED
- ALL FIRE WALL PENETRATIONS SHALL BE SEALED WITH FIRE RATED FOAM SEALANT (BOTH SIDES OF WALL). SEALANT TYPE SHALL HAVE A COMPATIBLE RATING WITH THE WALL SYSTEM.
- ALL CORRIDOR/LOBBY WALLS SHALL BE RATED FOR 1 HOUR WITH OPENINGS AND DOORS 20 MINUTES.
- WOOD FRAMING, BLOCKING, SHEATHING OR BRACING SHALL BE FIRE RETARDANT TREATED (UNLESS NOTED OTHERWISE).
- PROVIDE MANUAL MECSHADE BLINDS FULL LENGTH OF WINDOW AT ALL EXTERIOR WINDOWS TYPICAL.

ISSUE	DATE	DESCRIPTION
3	5/16/16	VALUE ENGINEERING

LEGEND

- FIRE EXTINGUISHER
- FIRE EXTINGUISHER CABINET
- SMALL KNOX BOX

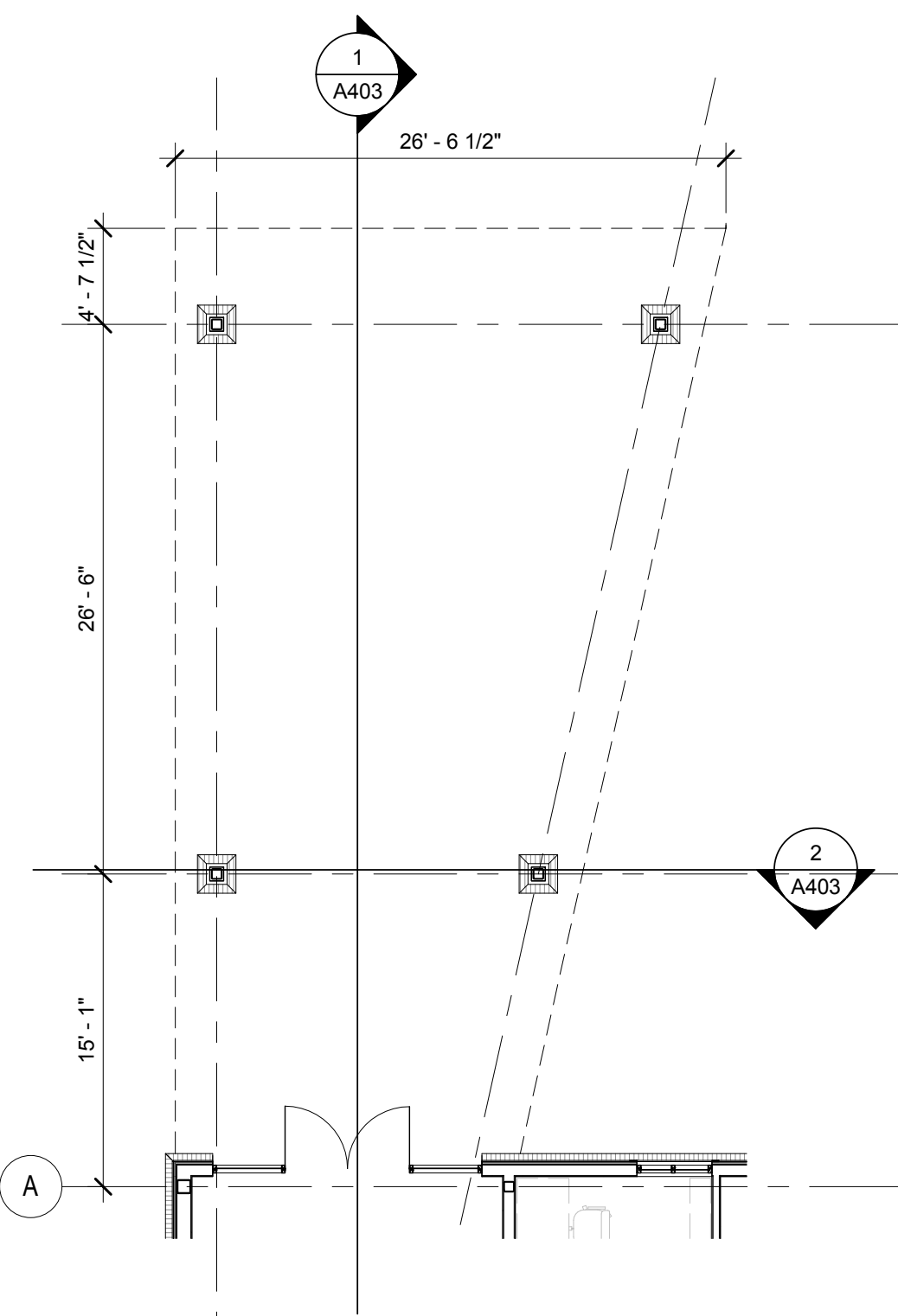
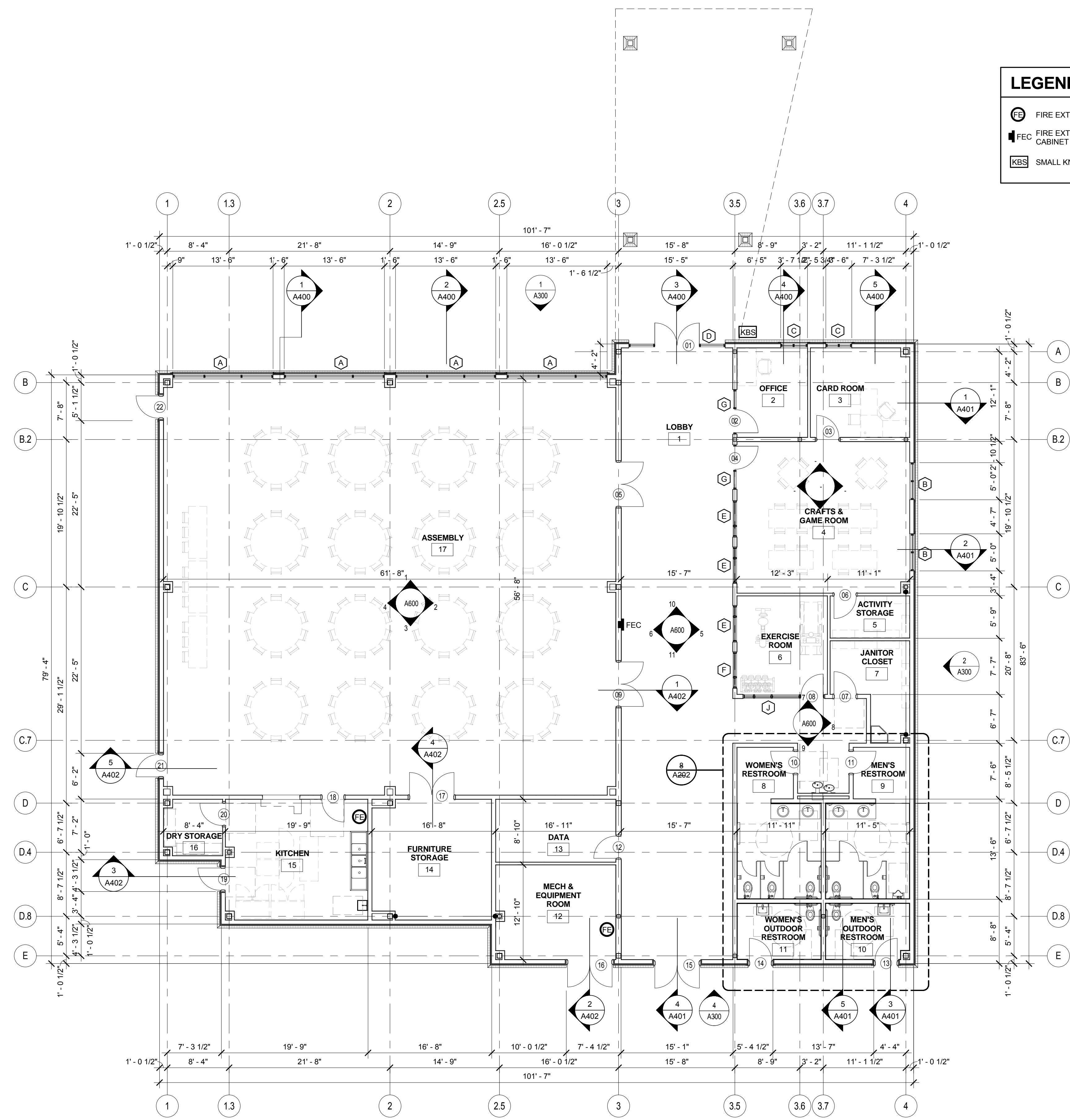

2 | CANOPY PLAN
SCALE: 1/8" = 1'-0"

1 | FLOOR PLAN
SCALE: 1/8" = 1'-0"



Boucher Design Group LLC
Members A.I.A.
6802 Maple Ridge, Suite 200
Bellaire, Texas 77401
Tel. 713.785.3644
www.bdgap.com

This document is an instrument of service protected by the copyright law of the United States of America, 17 U.S.C §102, and shall not be copied or reproduced without the express written consent of Boucher Design Group, LLC. 2016

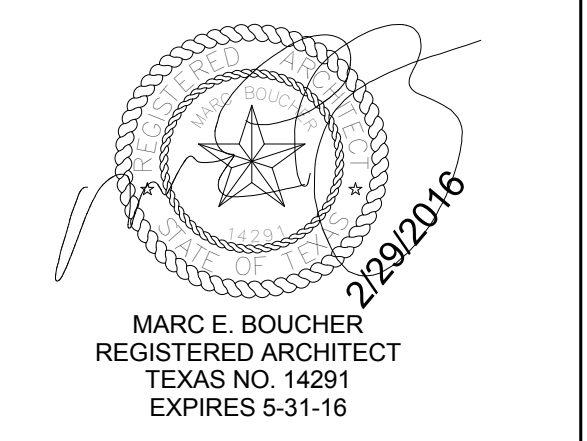

BAYSIDE COMMUNITY CENTER
BACLIFF, TEXAS
GALVESTON COUNTY

DATE	12/08/2015
PROJECT NO.	1409000
DRAWN BY	BW
CHECKED BY	BA

FLOOR PLAN

A200
© COPYRIGHT 2016 BOUCHER DESIGN GROUP, LLC

ISSUE	DATE	DESCRIPTION
3	5/16/16	VALUE ENGINEERING

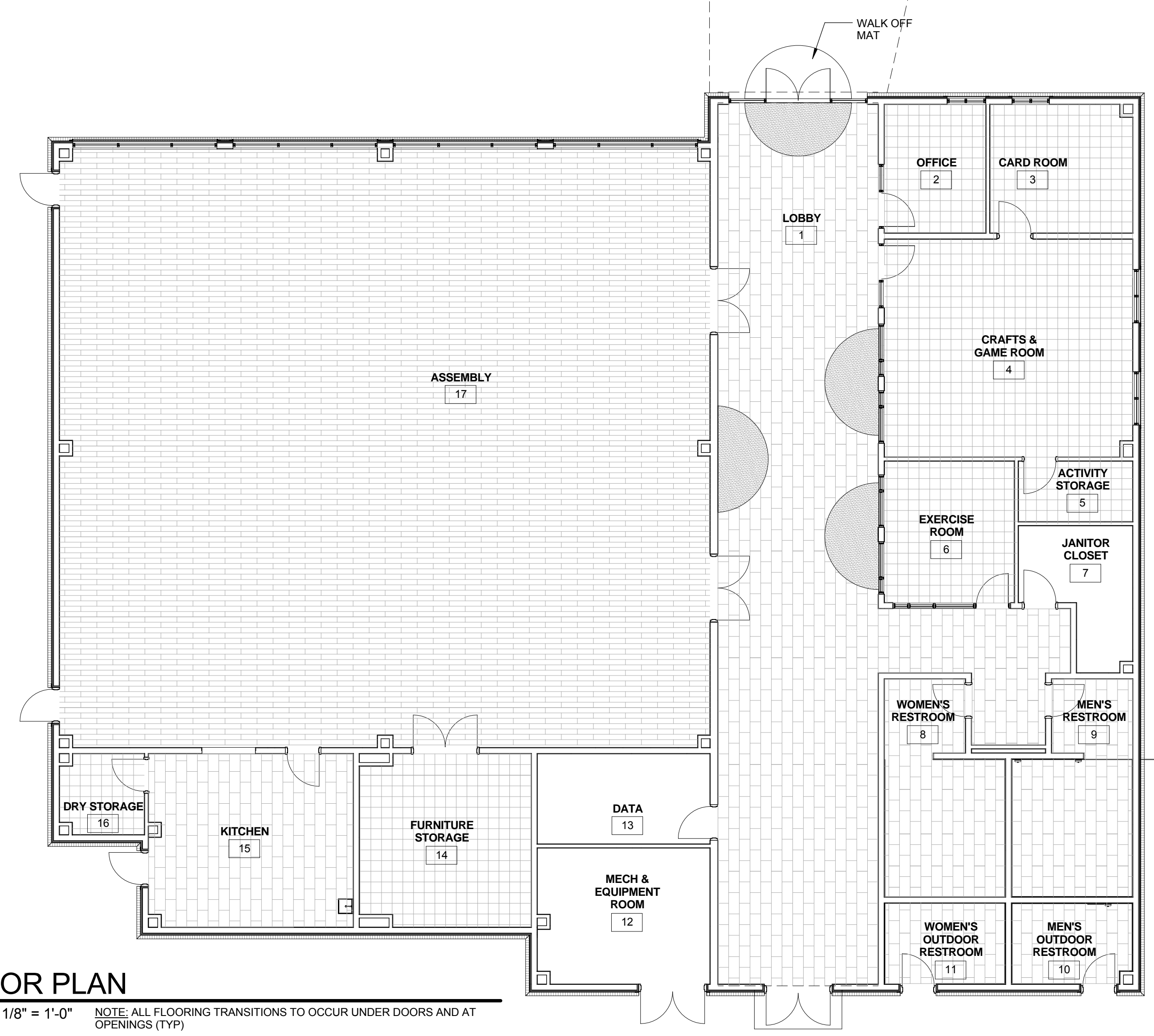

ROOM FINISH SCHEDULE

NO.	ROOM NAME	FLOOR	BASE	WALLS				CEILING	CEILING HEIGHT	REMARKS
				NORTH	SOUTH	EAST	WEST			
1	LOBBY	PT1/CPT	B1	P1	P1	P1	P1	APC1	15'-0"	-
2	OFFICE	VCT	B1	P1	P1	P1	P1	APC1	10'-0"	-
3	CARD OFFICE	VCT	B1	P1	P1	P1	P1	APC1	10'-0"	-
4	CRAFTS & GAME ROOM	VCT	B1	P1	P1	P1	P1	APC1	10'-0"	-
5	ACTIVITY STORAGE	VCT	B1	P1	P1	P1	P1	APC1	10'-0"	-
6	EXERCISE ROOM	VCT	B1	P1	P1	P1	P1	APC1	10'-0"	-
7	JANITOR CLOSET	S CONC	B1	P1/FRP	P1/FRP	P1/FRP	P1/FRP	APC2	10'-0"	FRP TO 5'-0 FROM FF
8	WOMEN'S RESTROOM	CT1	CT1	P1/CT1	P1/CT1	P1/CT1	P1/CT1	APC2	10'-0"	-
9	MEN'S RESTROOM	CT1	CT1	P1/CT1	P1/CT1	P1/CT1	P1/CT1	APC2	10'-0"	-
10	MEN'S RESTROOM	CT1	CT1	P1/CT1	P1/CT1	P1/CT1	P1/CT1	GYP	10'-0"	-
11	WOMEN'S RESTROOM	CT1	CT1	P1/CT1	P1/CT1	P1/CT1	P1/CT1	GYP	10'-0"	-
12	MECH & EQUIPMENT ROOM	S CONC	B1	P1	P1	P1	P1	EXP	EXP	-
13	DATA	S CONC	B1	P1	P1	P1	P1	APC1	10'-0"	-
14	FURNITURE STORAGE	VCT	B1	P1	P1	P1	P1	APC1	8'-0"	-
15	KITCHEN	PT1	B1	FRP	FRP	FRP	FRP	APC2	10'-0"	-
16	DRY STORAGE	VCT	B1	P1	P1	P1	P1	APC2	10'-0"	-
17	ASSEMBLY	VYL1	B1	P1	P1	P1	P1	APC1/GYP	VARIES	-

FINISH LEGEND

DESIGNATION	DESCRIPTION	MANUFACTURER	COLOR	MODEL NUMBER	NOTES:
FLOOR FINISHES					
CPT	CARPET	SHAW CONTACT GROUP	NEST	38760	-
VCT	VYNIL COMPOSITION TILE	ARMSTRONG - STANDARD EXCELON	COOL WHITE	51899	-
PT1	PORCELIN TILE	DALTILE	INTENSITY PEBBLE	VL72	-
VNL1	VYNIL PLANK FLOORING	KARNDGAN DESIGN FLOORING	LIME WASHED OAK	KP99	-
BASE FINISHES					
B1	RUBBER BASE	ROPPE	DOLPHIN	129	-
WALL FINISHES					
P1	PAINT	SHERMIN WILLIAMS	CEILING BRIGHT WHITE	SW 7007	-
CT1	CERAMIC TILE	LOBBY	WHITE	D100 (3"x6")	-
FRP	FIBER-REINFORCED PLASTIC PANELS	MARLITE	WHITE	S100G	-
CEILING FINISHES					
APC1	ACOUSTICAL PANEL CEILING	ARMSTRONG	WHITE	CORTEGA	-
APC2	VYNIL PANEL CEILING	LOBBY	FLAT WHITE	CLIMAPLUS 3270	-
MISC FINISHES					
PL-1	PLASTIC LAMINATE	WILSONART	TBD	-	BATHROOM COUNTER TOPS
PL-1	PLASTIC LAMINATE	WILSONART	TBD	-	TYPICAL WINDOW STOOL
PL-1	PLASTIC LAMINATE	WILSONART	TBD	-	INTERIOR DOOR LAMINATE
GROUT					
GR-1	GROUT	MAPEI	CHARCOAL	47	-
GR-2	GROUT	MAPEI	MATCH ADJACENT TILE COLOR	-	-



Boucher Design Group LLC
Members A.I.A.
6802 Mapleridge, Suite 200
Bellaire, Texas 77401
Tel. 713.785.3644
www.bdgap.com

This document is an instrument of service protected by the copyright law of the United States of America, 17 U.S.C §102, and shall not be copied or reproduced without the express written consent of Boucher Design Group, LLC. 2016

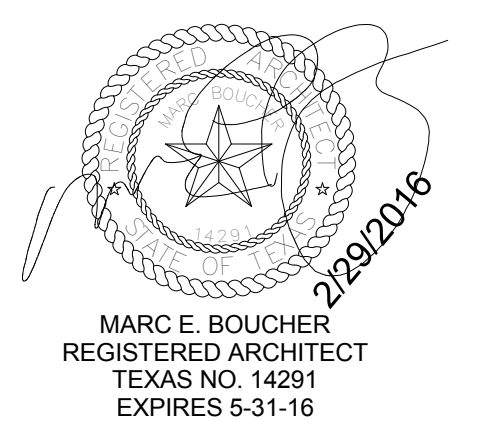

BAYSIDE COMMUNITY CENTER
BACLIFF, TEXAS
GALVESTON COUNTY

DATE	03/07/16
PROJECT NO.	1409000
DRAWN BY	Author
CHECKED BY	Checker

FINISH FLOOR PLAN

A200A
© COPYRIGHT 2016 BOUCHER DESIGN GROUP, LLC

C:\Users\bdg\Documents\REVIT PROJECTS\1409000_GALVESTON COMMUNITY CENTER_brian.rvt 6/9/2016 10:26:39 AM

ISSUE	DATE	DESCRIPTION
2	03/08/16	ADD ARCHITECTURE

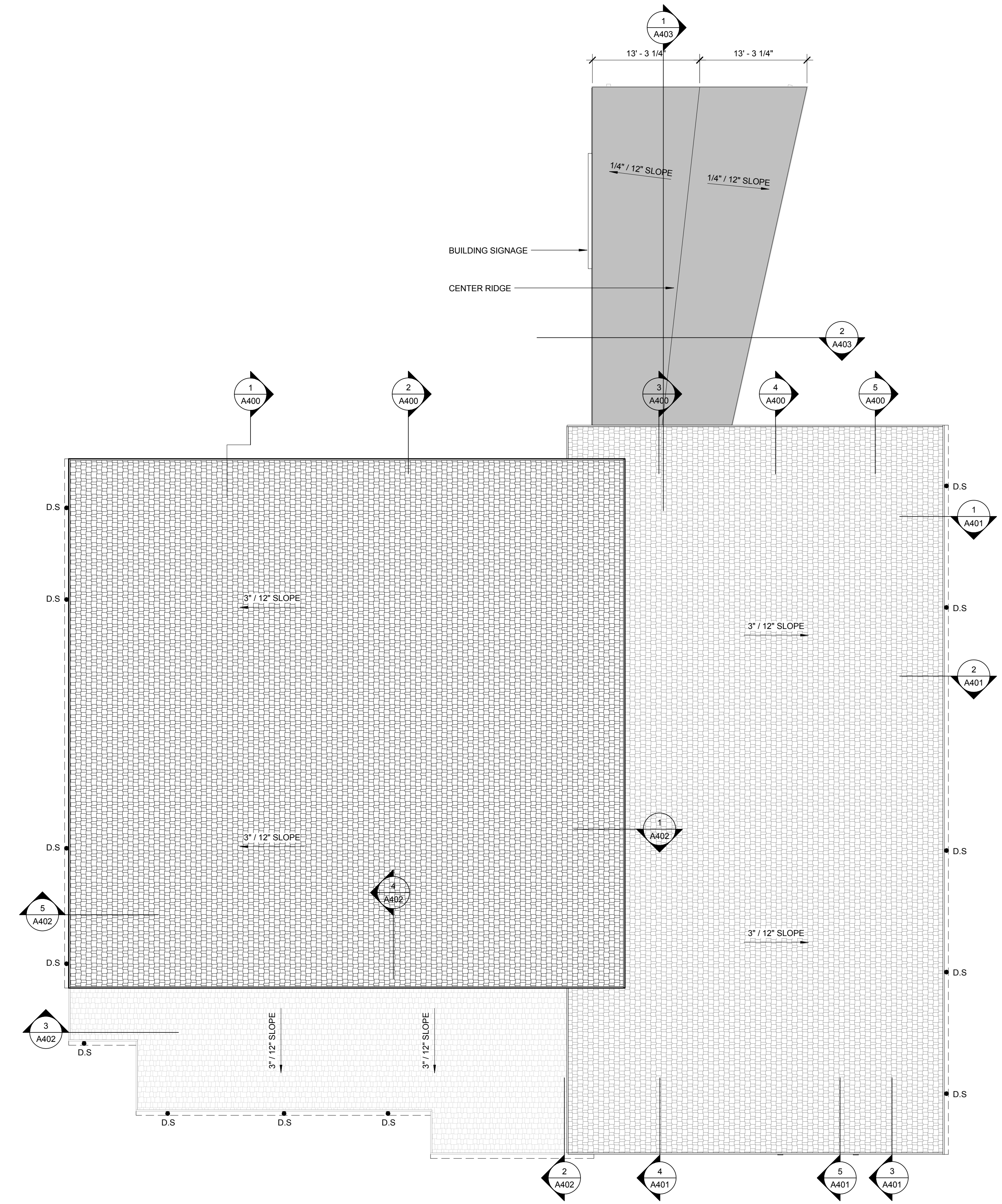

ROOF LEGEND

- ASPHALT SHINGLE ROOF OVER ICE AND WATER SHIELD TO MEET TPI REQUIREMENTS FOR 130MPH WIND
- D.S. PREFINISHED 6" X 6" DOWNSPOUT
- PREFINISHED 6" X 6" GUTTER
- 60 MIL TPO OVER 1/2" CD EXTERIOR PLYWOOD ON 1/2" TAPERED INSULATION



Boucher Design Group LLC
Members A.I.A.
6802 Mapleridge, Suite 200
Bellaire, Texas 77401
Tel. 713.785.3644
www.bdgap.com

This document is an instrument of service protected by the copyright law of the United States of America, 17 U.S.C §102, and shall not be copied or reproduced without the express written consent of Boucher Design Group, LLC. 2016

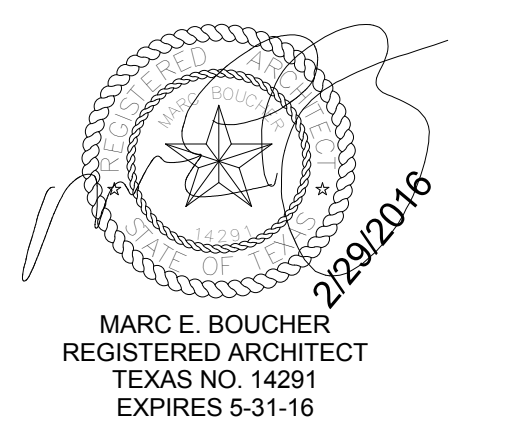

BAYSIDE COMMUNITY CENTER
BACLIFF, TEXAS
GALVESTON COUNTY

DATE	02/29/2016
PROJECT NO.	1409000
DRAWN BY	BW
CHECKED BY	BPA

ROOF PLAN

1 | ROOF PLAN
SCALE: 1/8" = 1'-0"

A201
© COPYRIGHT 2016 BOUCHER DESIGN GROUP, LLC

C:\Users\bsid\Documents\REVIT PROJECTS\1409000_GALVESTON COMMUNITY CENTER_brian.rvt 6/9/2016 10:28:43 AM

ISSUE	DATE	DESCRIPTION
2	03/08/16	ADD ENGINEERING

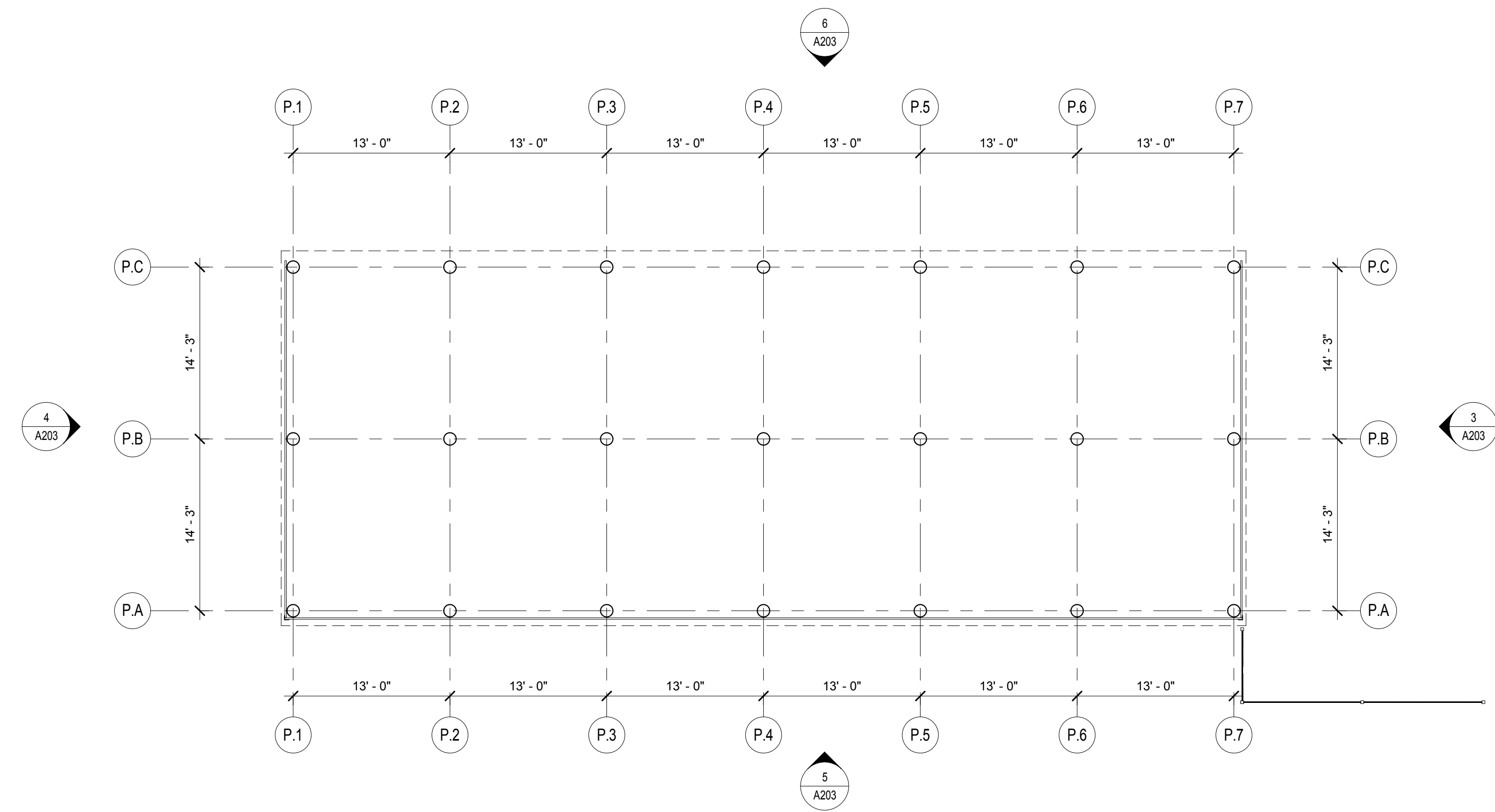

NOTE:
WALL PANEL DESIGN BASIS MBCI PBR PANEL WITH MANUFACTURE CLOSURE TRIM AT ALL CORNERS

2 | FLOOR PLAN
SCALE: 1/8" = 1'-0"



Boucher Design Group LLC
Members A.I.A.
6802 Mapleridge, Suite 200
Bellaire, Texas 77401
Tel. 713.785.3644
www.bdgap.com

This document is an instrument of service protected by the copyright law of the United States of America, 17 U.S.C §102, and shall not be copied or reproduced without the express written consent of Boucher Design Group, LLC. 2016

PRELIMINARY
MAY NOT BE USED FOR REGULATORY APPROVAL, PERMITTING, OR CONSTRUCTION MARC E. BOUCHER, REGISTERED ARCHITECT, TEXAS NO. 14291, EXPIRES 05-31-16

BAYSIDE COMMUNITY CENTER
BACLIFF, TEXAS
GALVESTON COUNTY

DATE	02/29/16
PROJECT NO.	1409000
DRAWN BY	BPA
CHECKED BY	BPA

POLE BARN

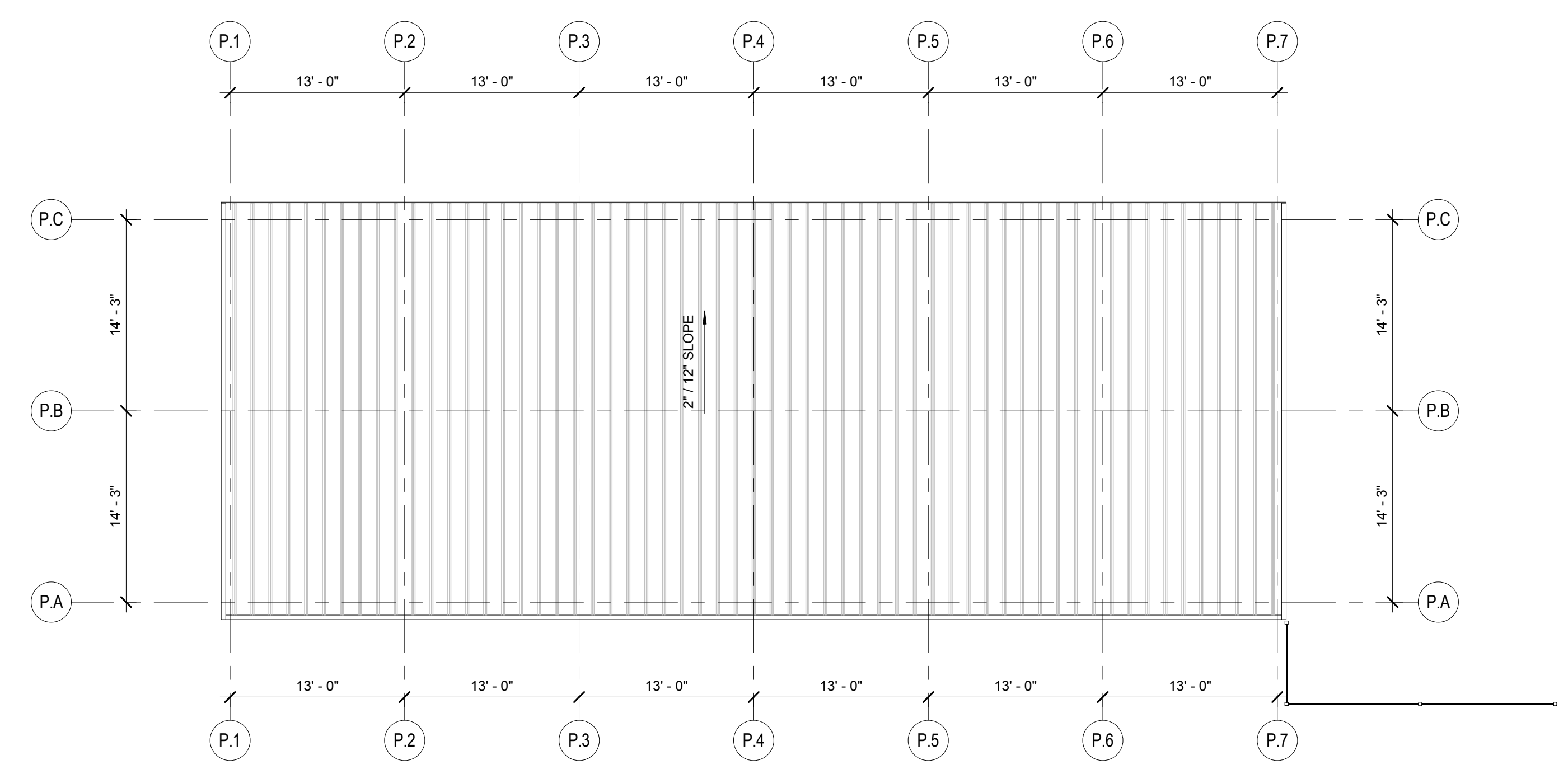

NOTE:
WALL PANEL DESIGN BASIS MBCI PBR PANEL WITH MANUFACTURE CLOSURE TRIM AT ALL CORNERS

1 | ROOF PLAN
SCALE: 1/8" = 1'-0"

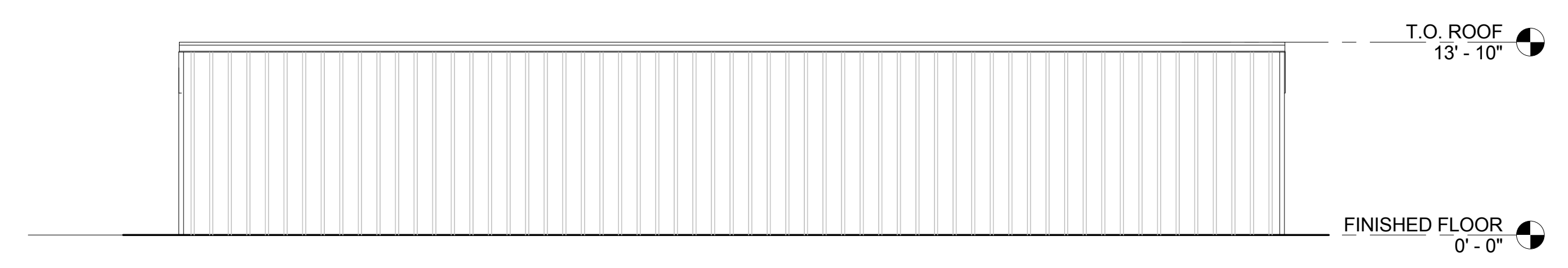

6 | ELEVATION
SCALE: 1/8" = 1'-0"

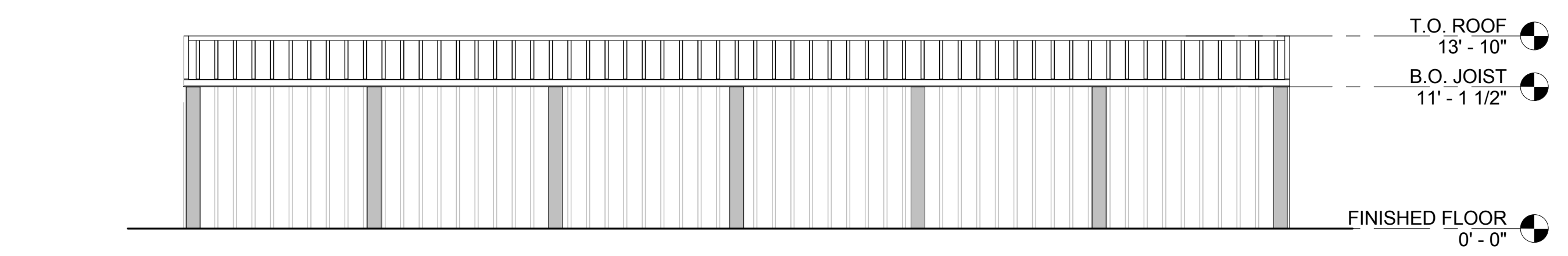

5 | ELEVATION
SCALE: 1/8" = 1'-0"

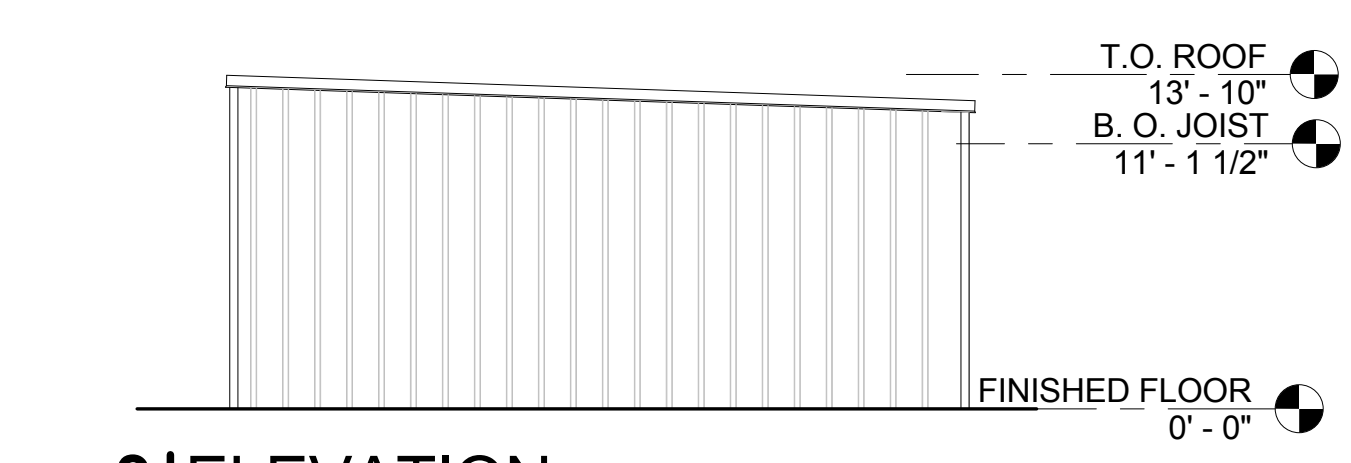

3 | ELEVATION
SCALE: 1/8" = 1'-0"

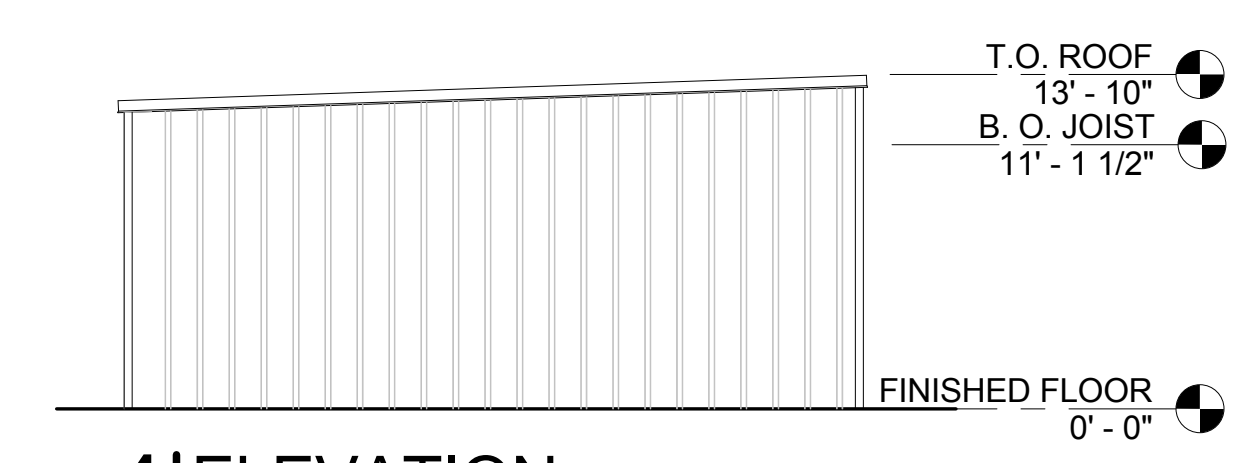

4 | ELEVATION
SCALE: 1/8" = 1'-0"

C:\Users\bristal\Documents\REVIT PROJECTS\1409000_GALVESTON COMMUNITY CENTER_brian.rvt 6/9/2016 10:26:52 AM

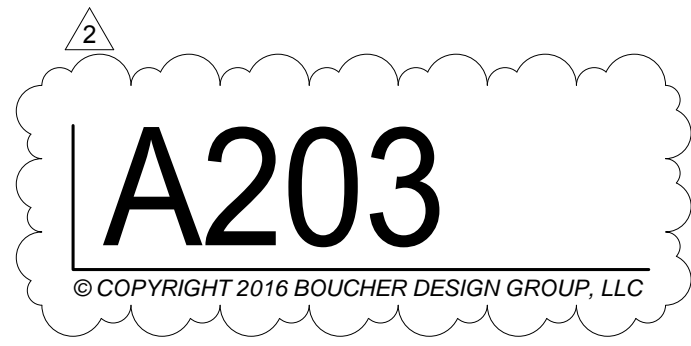

ISSUE	DATE	DESCRIPTION
3	5/16/16	VALUE ENGINEERING

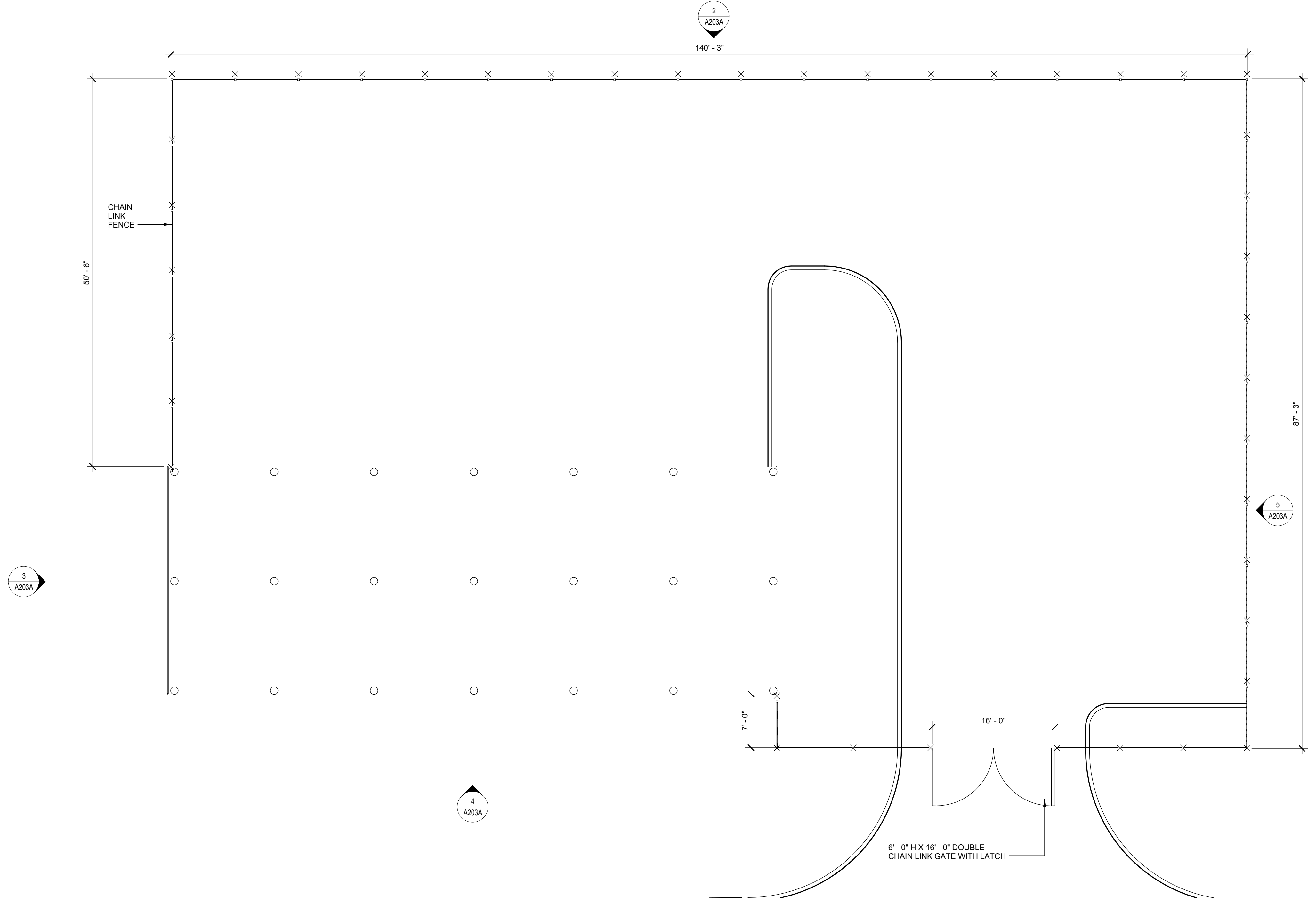
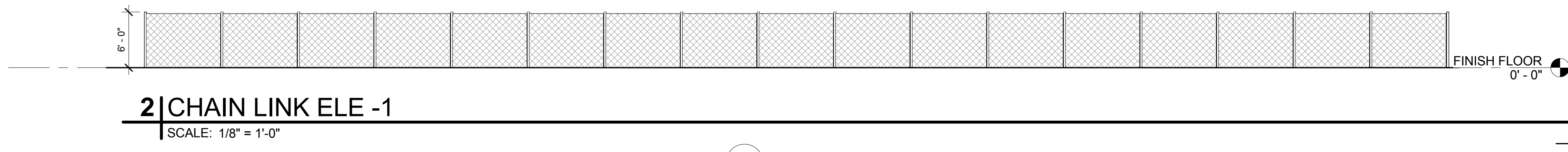
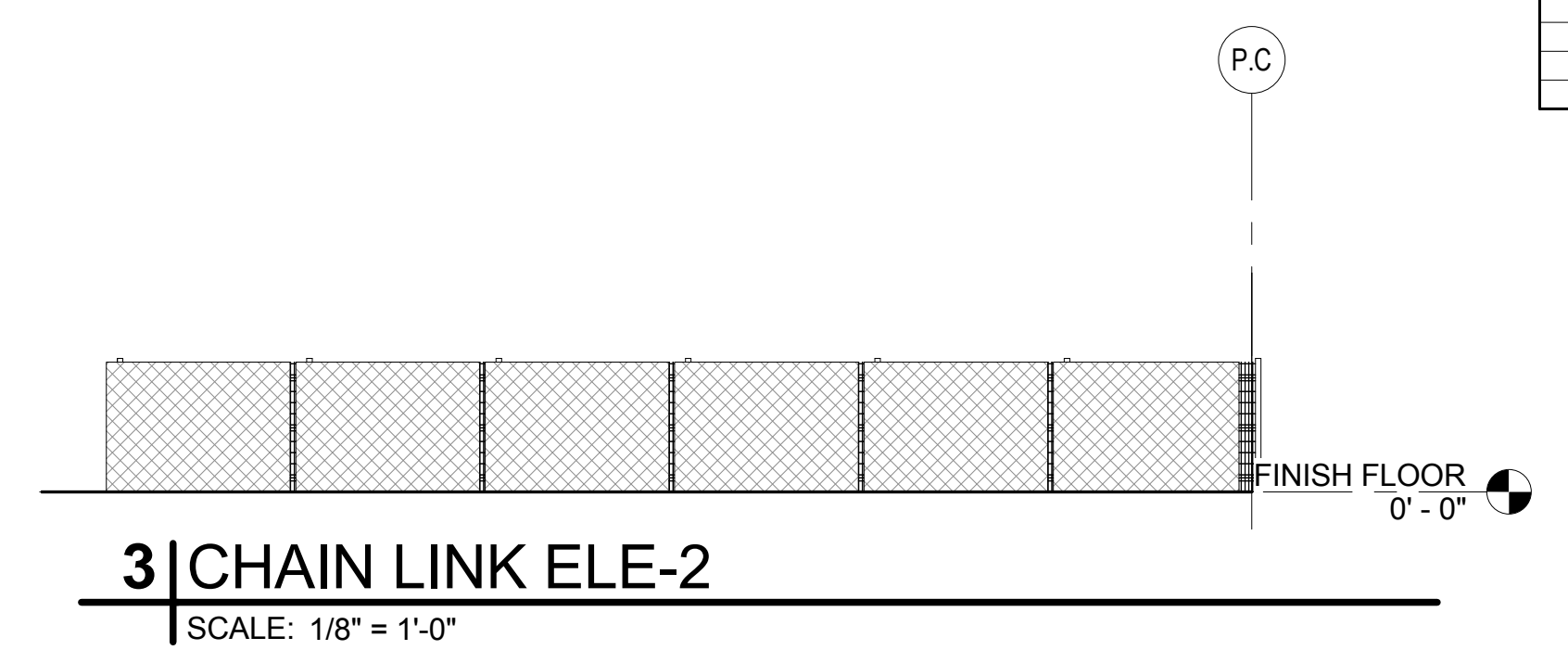
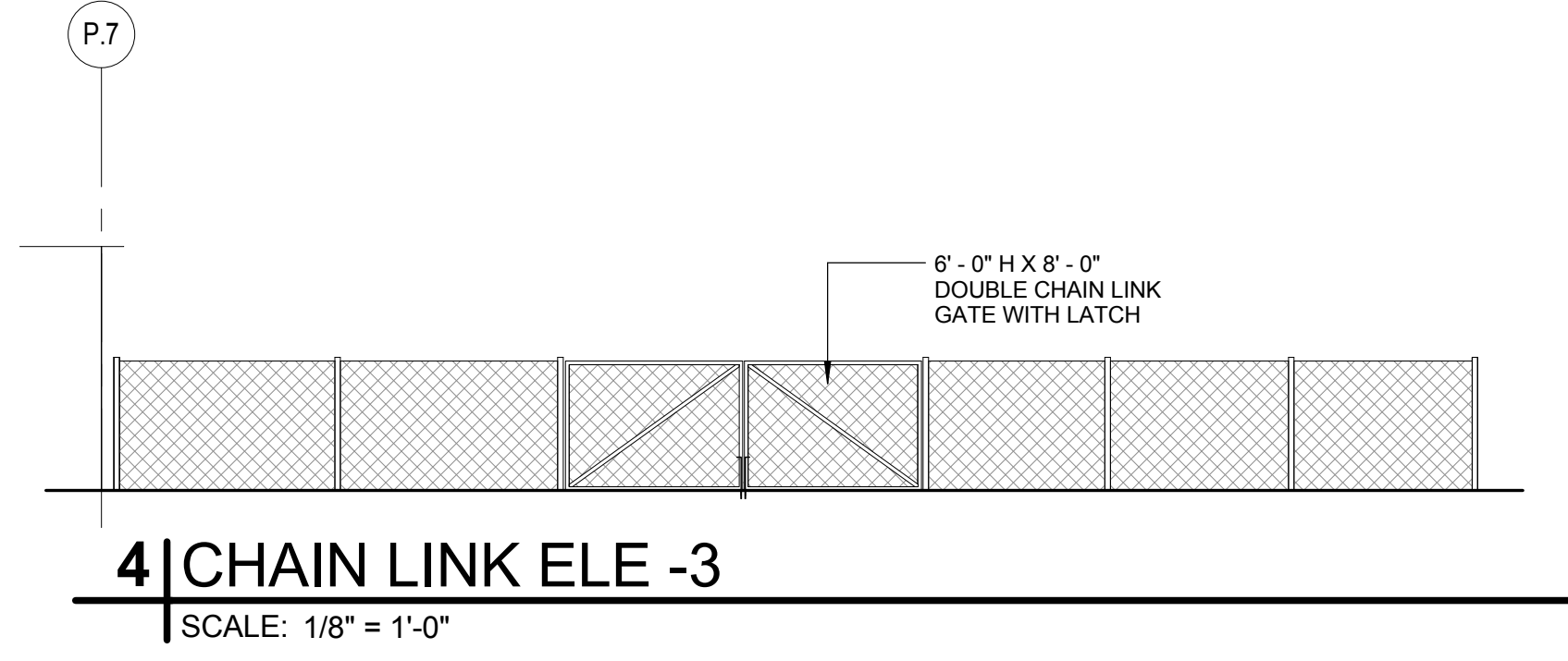
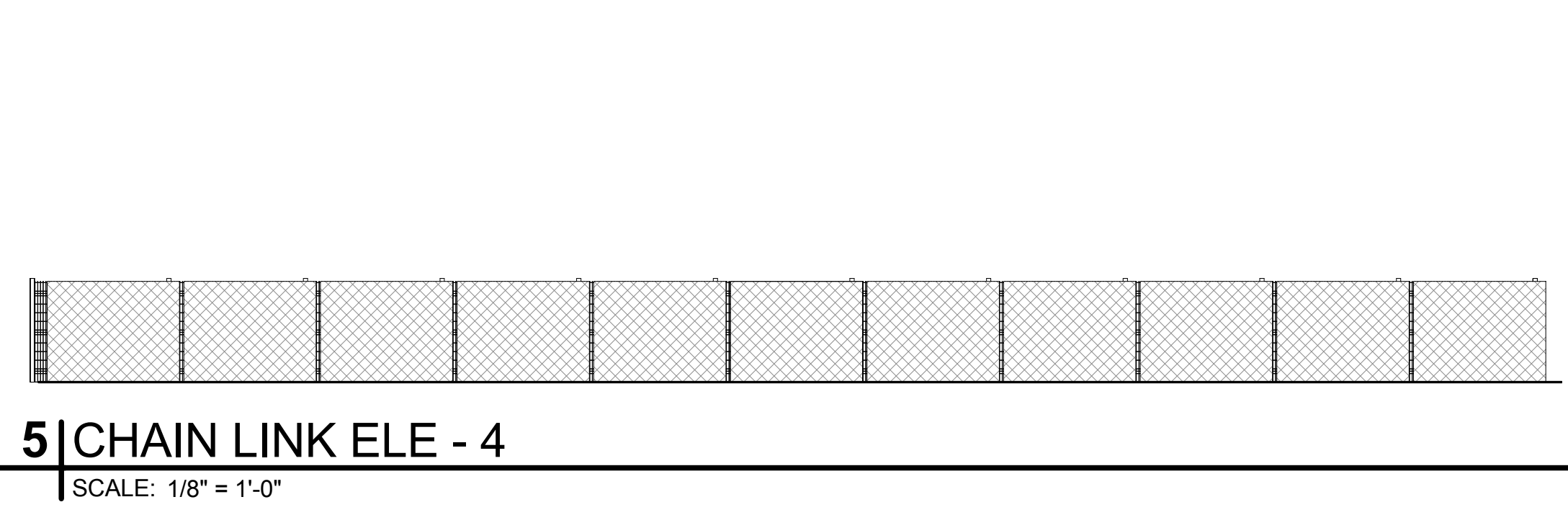

bdG
architecture
+ planning
 boucher design group

Boucher Design Group LLC
 Members A.I.A.
 6802 Mapleridge, Suite 200
 Bellaire, Texas 77401
 Tel. 713.785.3644
 www.bdgap.com

This document is an instrument of service protected by the copyright law of the United States of America, 17 U.S.C §102, and shall not be copied or reproduced without the express written consent of Boucher Design Group, LLC. 2016

PRELIMINARY
 MAY NOT BE USED FOR REGULATORY APPROVAL, PERMITTING, OR CONSTRUCTION MARC E. BOUCHER, REGISTERED ARCHITECT, TEXAS NO. 14291, EXPIRES 05-31-16

BAYSIDE COMMUNITY CENTER	
BACLIFF, TEXAS	
GALVESTON COUNTY	
DATE	05/16/16
PROJECT NO.	1409000
DRAWN BY	Author
CHECKED BY	Checker

POLE BARN ENLARGED PLAN

A203A
© COPYRIGHT 2016 BOUCHER DESIGN GROUP, LLC

1 | MASTER SITE PLAN
 SCALE: 1/8" = 1'-0"

C:\Users\bdg\Documents\REVIT PROJECTS\1409000_GALVESTON COMMUNITY CENTER_brian.rvt 6/9/2016 10:29:11 AM

ISSUE	DATE	DESCRIPTION
3	5/16/16	VALUE ENGINEERING

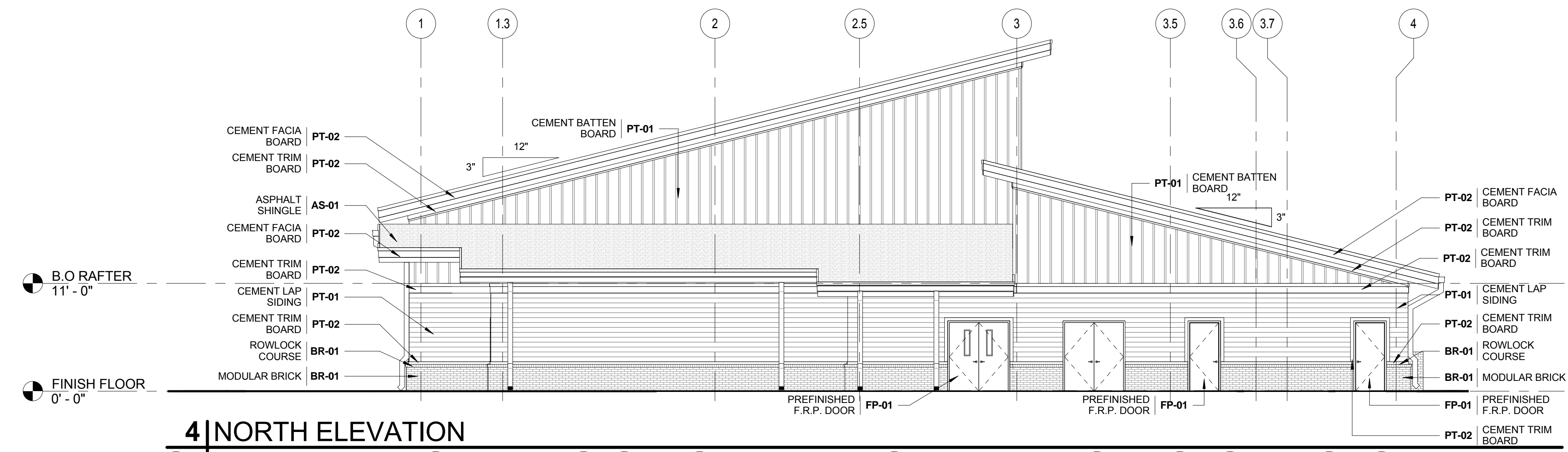

4 | NORTH ELEVATION
SCALE: 1/8" = 1'-0"

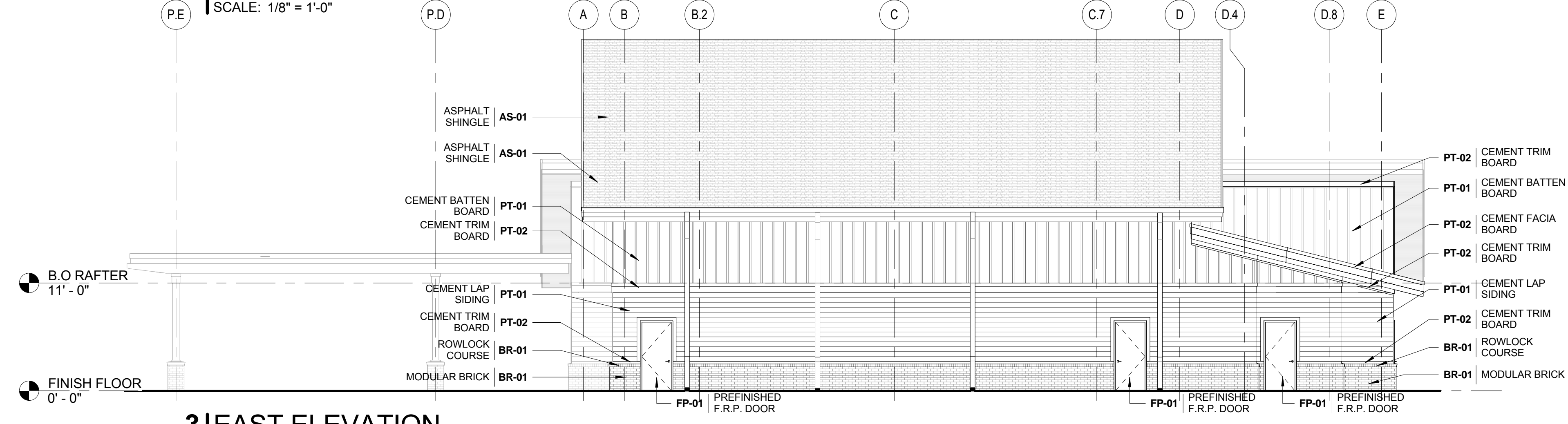

3 | EAST ELEVATION
SCALE: 1/8" = 1'-0"

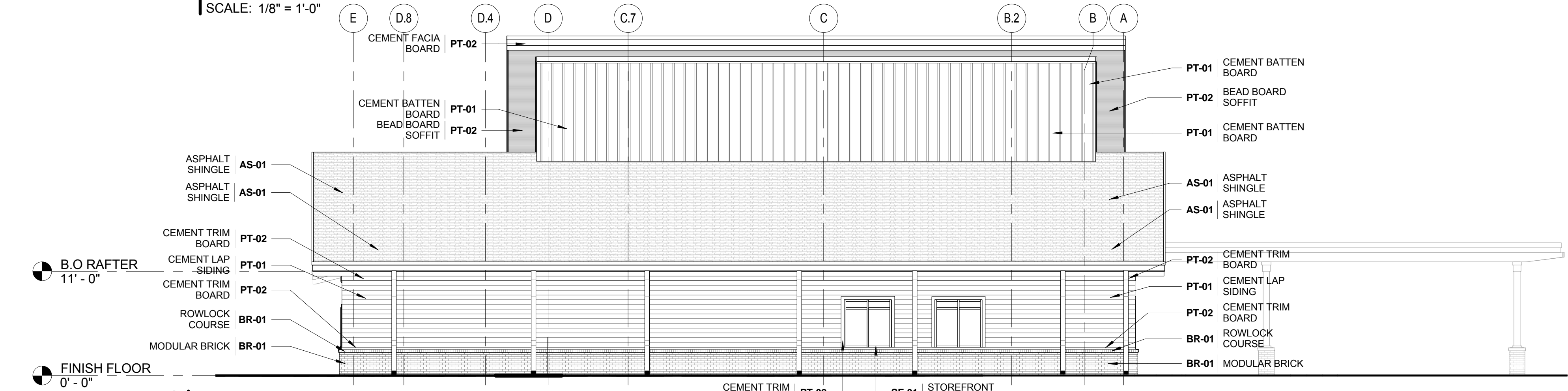

2 | WEST ELEVATION
SCALE: 1/8" = 1'-0"

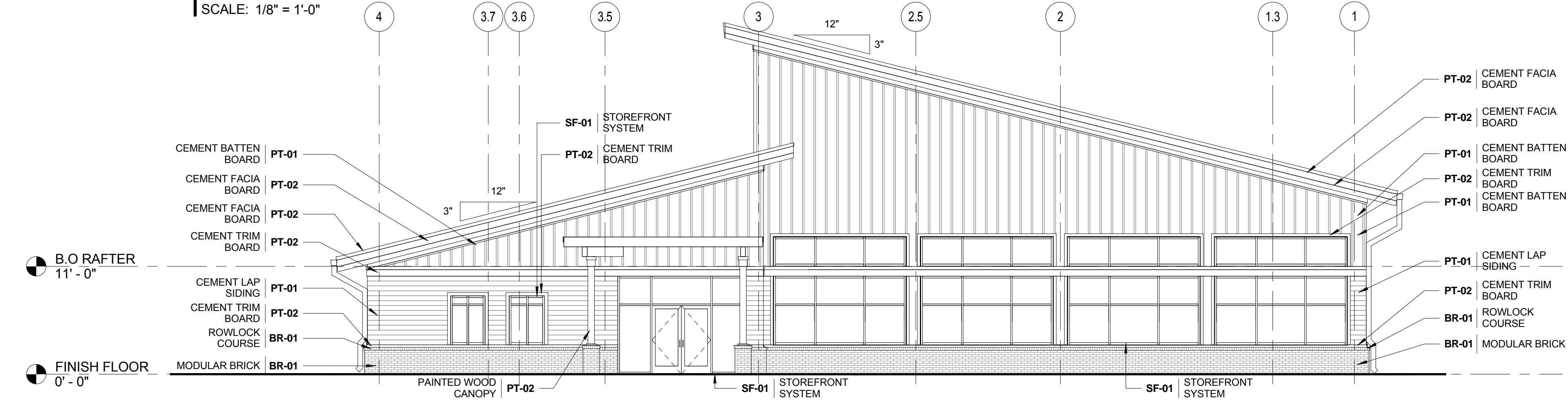

1 | SOUTH ELEVATION
SCALE: 1/8" = 1'-0"

- GENERAL NOTES**
- DO NOT SCALE DRAWINGS
 - DIMENSIONS ARE FROM FACE OF FINISHED WALL TO FACE OF FINISHED WALL UNLESS NOTED OTHERWISE. (U.N.O.)
 - IT IS THE RESPONSIBILITY OF THE GENERAL CONTRACTOR TO CROSS-CHECK THE STRUCTURAL AND ELECTRICAL DRAWINGS WITH THE ARCHITECTURAL DRAWINGS PRIOR TO THE ORDERING / INSTALLATION OF STEEL AND ELECTRICAL WORK. ANY DISCREPANCIES BETWEEN THE ARCHITECTURAL AND STRUCTURAL AND ELECTRICAL DRAWINGS SHALL BE BROUGHT TO THE ARCHITECTS' ATTENTION FOR IMMEDIATE CLARIFICATION.
 - ALL CONSTRUCTION SHALL COMPLY WITH ALL APPLICABLE STATE, CITY AND LOCAL CODES AND ORDINANCES IN THE LOCATION OF THE PROJECT.
 - WHERE EXISTING CONDITIONS ARE CUT OR DISTURBED TO PERMIT INSTALLATION OF NEW WORK, MATCH AND PATCH EXISTING DISTURBED CONSTRUCTION TO ORIGINAL CONDITION UNLESS OTHERWISE NOTED.
 - ALL MATERIALS NOT LABELED ARE TYPICAL FOR ALL SIMILAR LOCATIONS. QUESTIONS SHALL BE REFERRED TO THE ARCHITECT.
 - ALL EXTERIOR MATERIALS TO BE REPAIRED, CLEANED, AND PAINTED AS REQUIRED.

DO NOT SCALE THESE DRAWINGS FOR DIMENSIONAL INFORMATION. REFER TO DIMENSIONS ON THE FLOOR PLAN AND THE ENLARGED PLANS. IF THERE IS A CONFLICT WITH THE PLAN DIMENSIONS OR AN EXISTING FIELD CONDITION CONTACT THE ARCHITECT.

MATERIAL LEGEND

MARK	DESCRIPTION	MANUFACTURER	COLOR
AS-01	ASPHALT SHINGLE ROOF	CERTAINTEED	MAX DEF MOIRE BLACK
BR-01	BRICK	ACME BRICK	GLACIER WHITE - MODULAR
FP-01	FIBER GLASS	CHEM-PRUF	COLOR T.B.D.
LM-01			
MT-01	METAL	BERRIDGE	STANDING SEAM METAL AWNING
P1			Paint - Beige
P2			GWB
PL-1			
PT-01	PAINT	SHERWIN WILLIAMS	SW7624 SLATE TILE
PT-02	PAINT	SHERWIN WILLIAMS	SW7007 BRIGHT WHITE
SF-01	ALUMINUM	KAWNEER	CLEAR ANODIZED
TL-01	TILE	T.B.D.	3"X6" WHITE SUBWAY TILE WITH DARK GREY GROUT



Boucher Design Group LLC
Members A.I.A.
6802 Mapleridge, Suite 200
Bellaire, Texas 77401
Tel. 713.785.3644
www.bdgap.com

This document is an instrument of service protected by the copyright law of the United States of America, 17 U.S.C §102, and shall not be copied or reproduced without the express written consent of Boucher Design Group, LLC. 2016

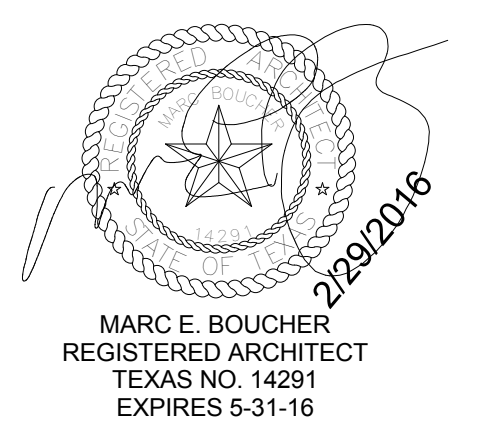

BAYSIDE COMMUNITY CENTER

BACLIFF, TEXAS

GALVESTON COUNTY

DATE	12/08/2015
PROJECT NO.	1409000
DRAWN BY	BW
CHECKED BY	BA

EXTERIOR ELEVATIONS

A300

© COPYRIGHT 2016 BOUCHER DESIGN GROUP, LLC

ISSUE	DATE	DESCRIPTION
2	02/29/16	ADD ARCHITECTURE

C:\Users\stian\Documents\REVIT PROJECTS\1409000_GALVESTON COMMUNITY CENTER_brian.rvt 8/9/2016 10:29:20 AM

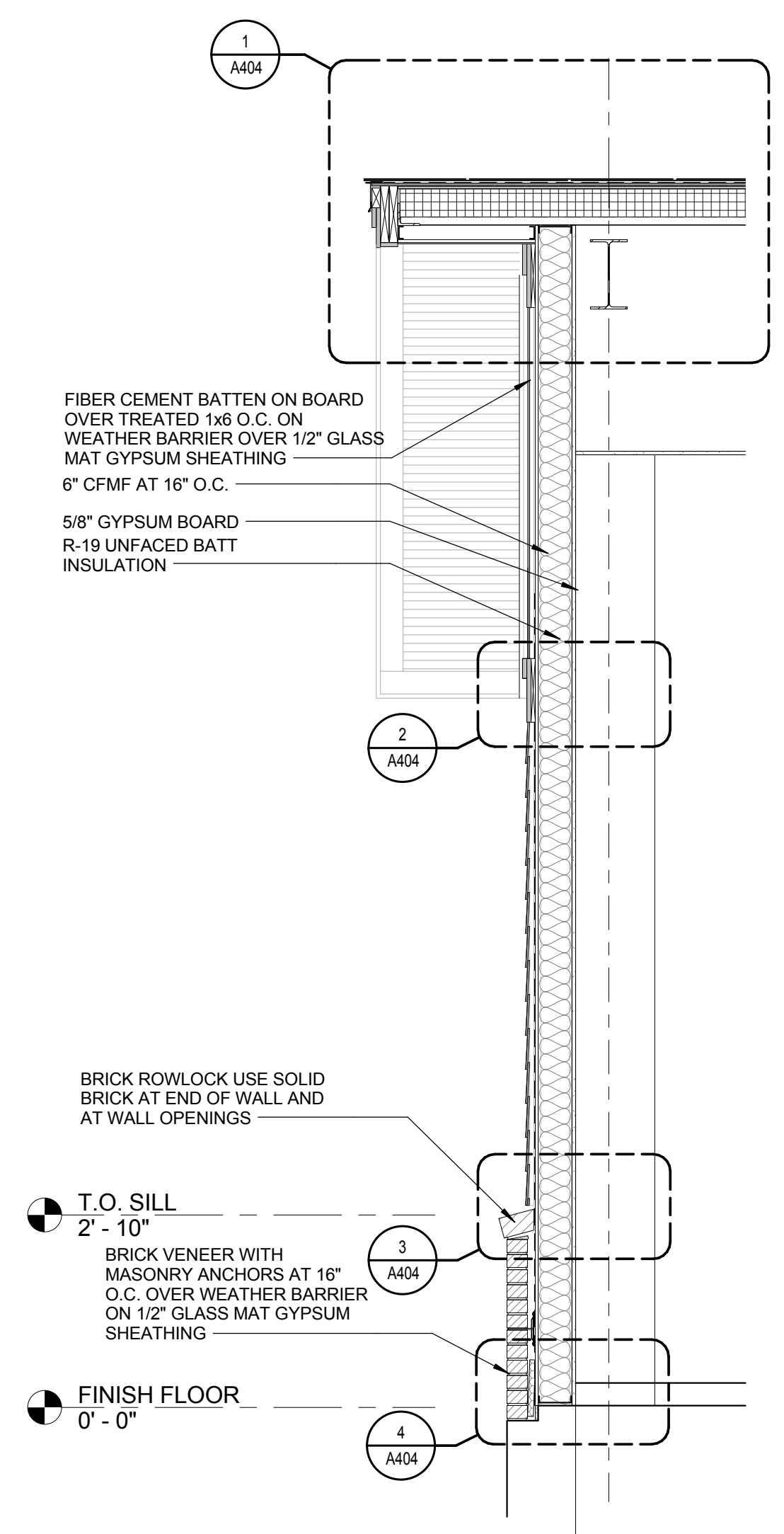

5 | WALL SECTION
SCALE: 1/2" = 1'-0"

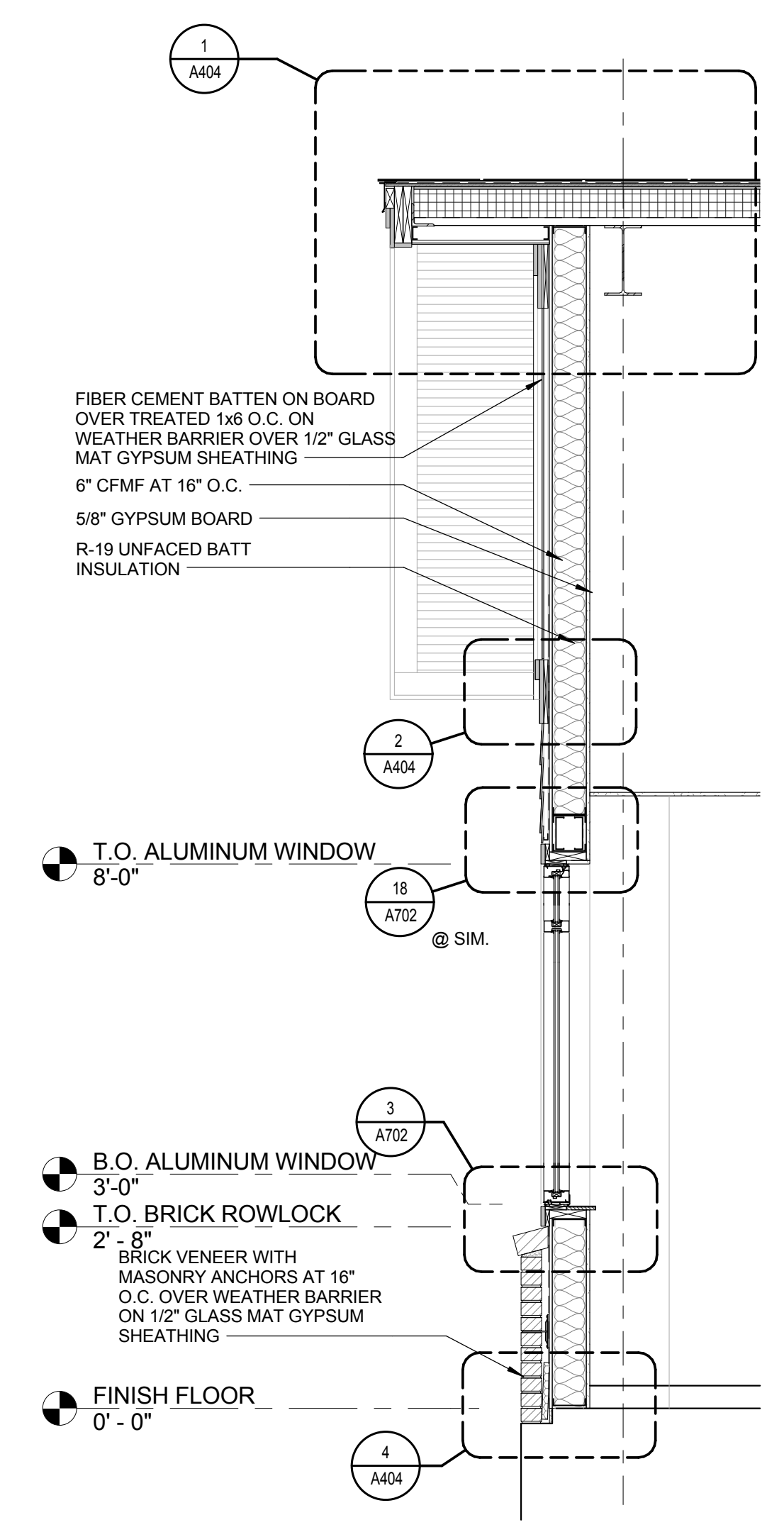

4 | WALL SECTION
SCALE: 1/2" = 1'-0"

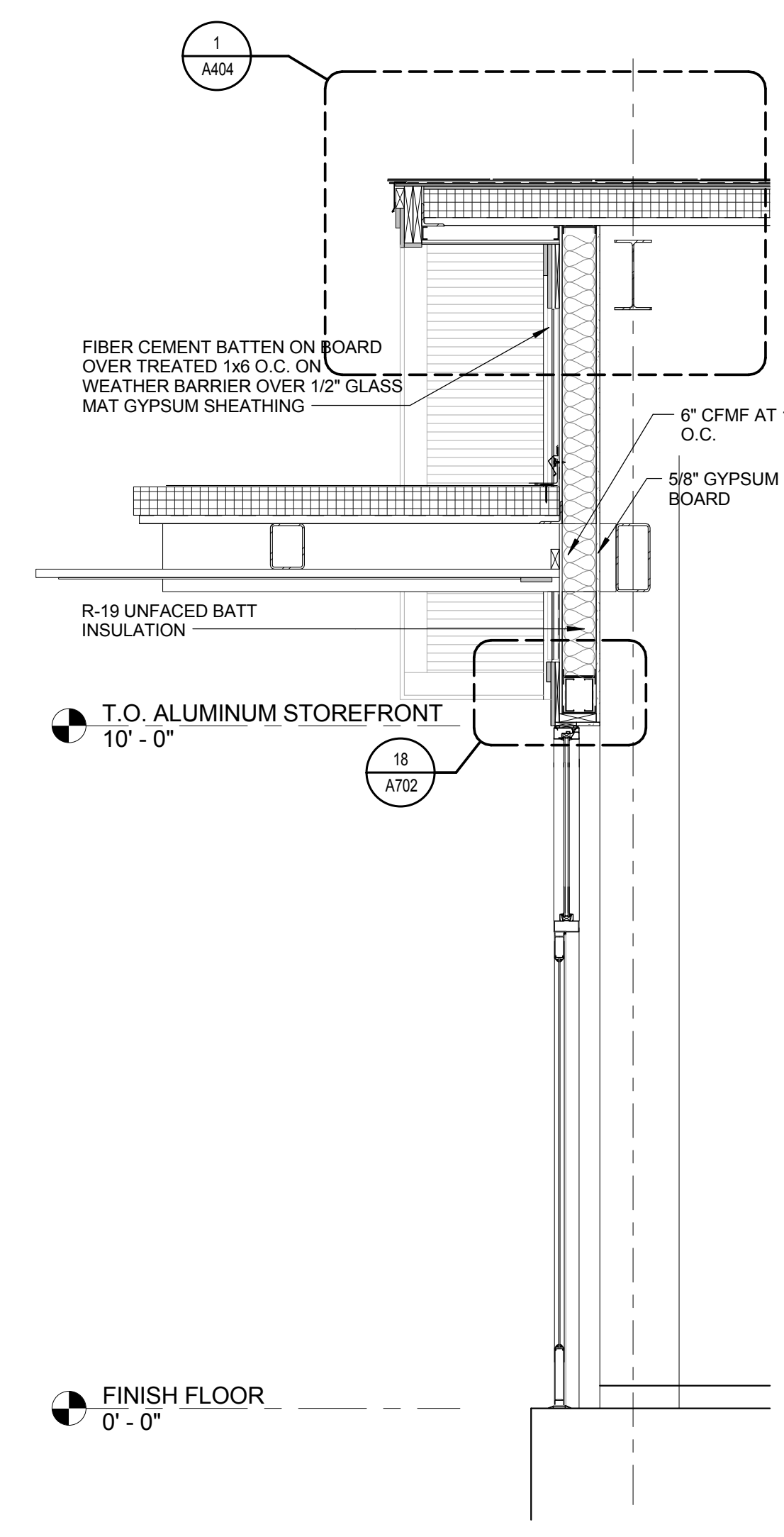

3 | WALL SECTION
SCALE: 1/2" = 1'-0"

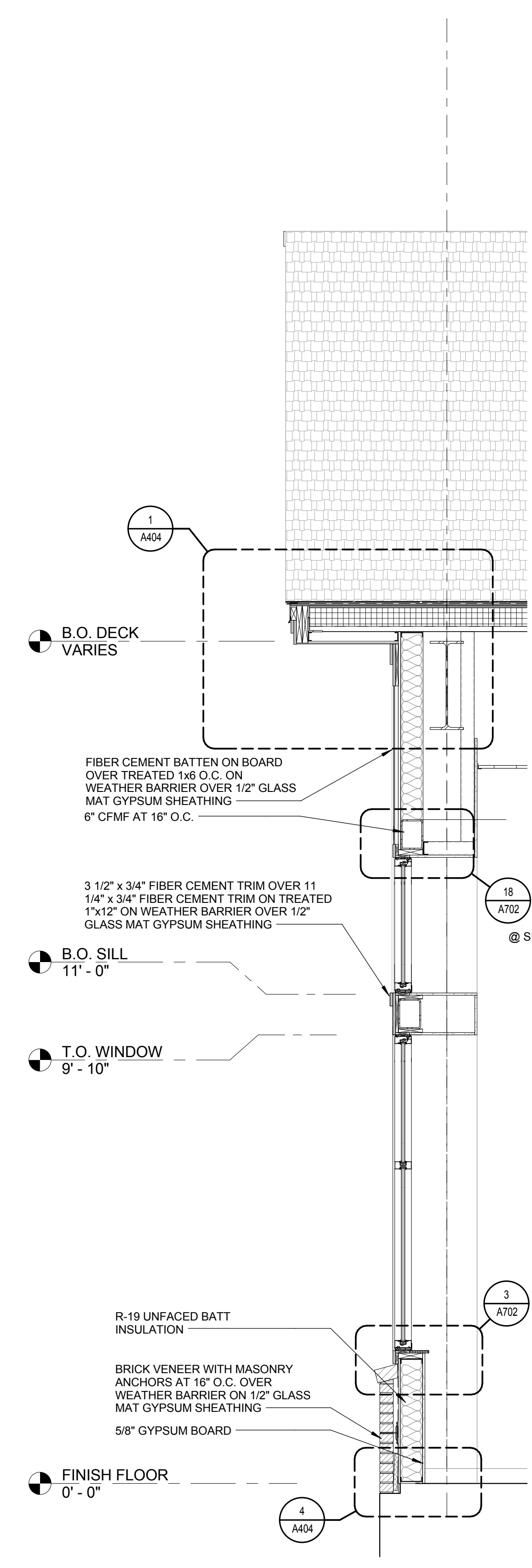

2 | WALL SECTION
SCALE: 1/2" = 1'-0"

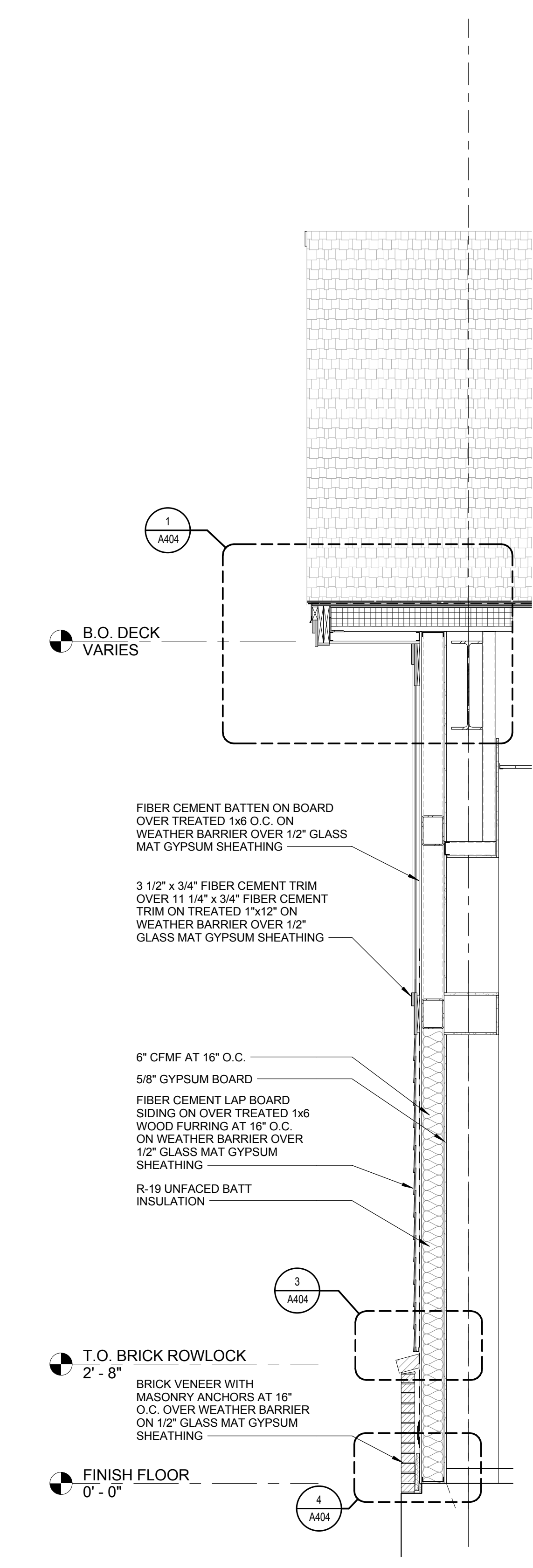

1 | WALL SECTION
SCALE: 1/2" = 1'-0"



Boucher Design Group LLC
Members A.I.A.
6802 Mapleridge, Suite 200
Bellaire, Texas 77401
Tel. 713.785.3644
www.bdgap.com

This document is an instrument of service protected by the copyright law of the United States of America, 17 U.S.C §102, and shall not be copied or reproduced without the express written consent of Boucher Design Group, LLC. 2016

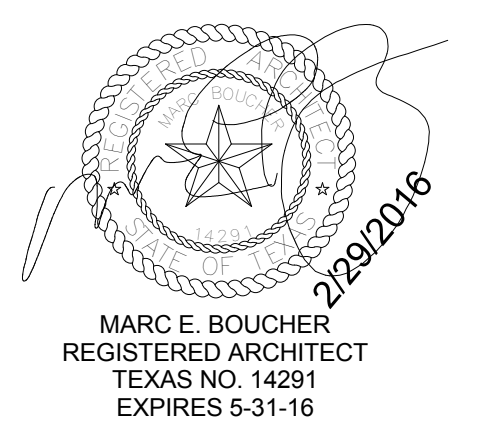

BAYSIDE COMMUNITY CENTER
BACLIFF, TEXAS
GALVESTON COUNTY

DATE 02/29/2016
PROJECT NO. 1409000
DRAWN BY BW
CHECKED BY BPA

WALL SECTIONS

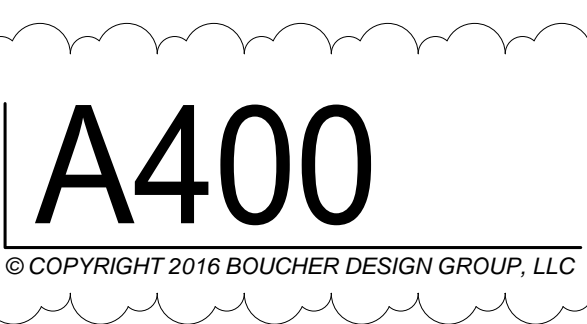

ISSUE	DATE	DESCRIPTION
2	03/08/16	ADD EXTERIOR FINISHING

C:\Users\stian\Documents\REVIT PROJECTS\1409000_GALVESTON COMMUNITY CENTER_1.rvt

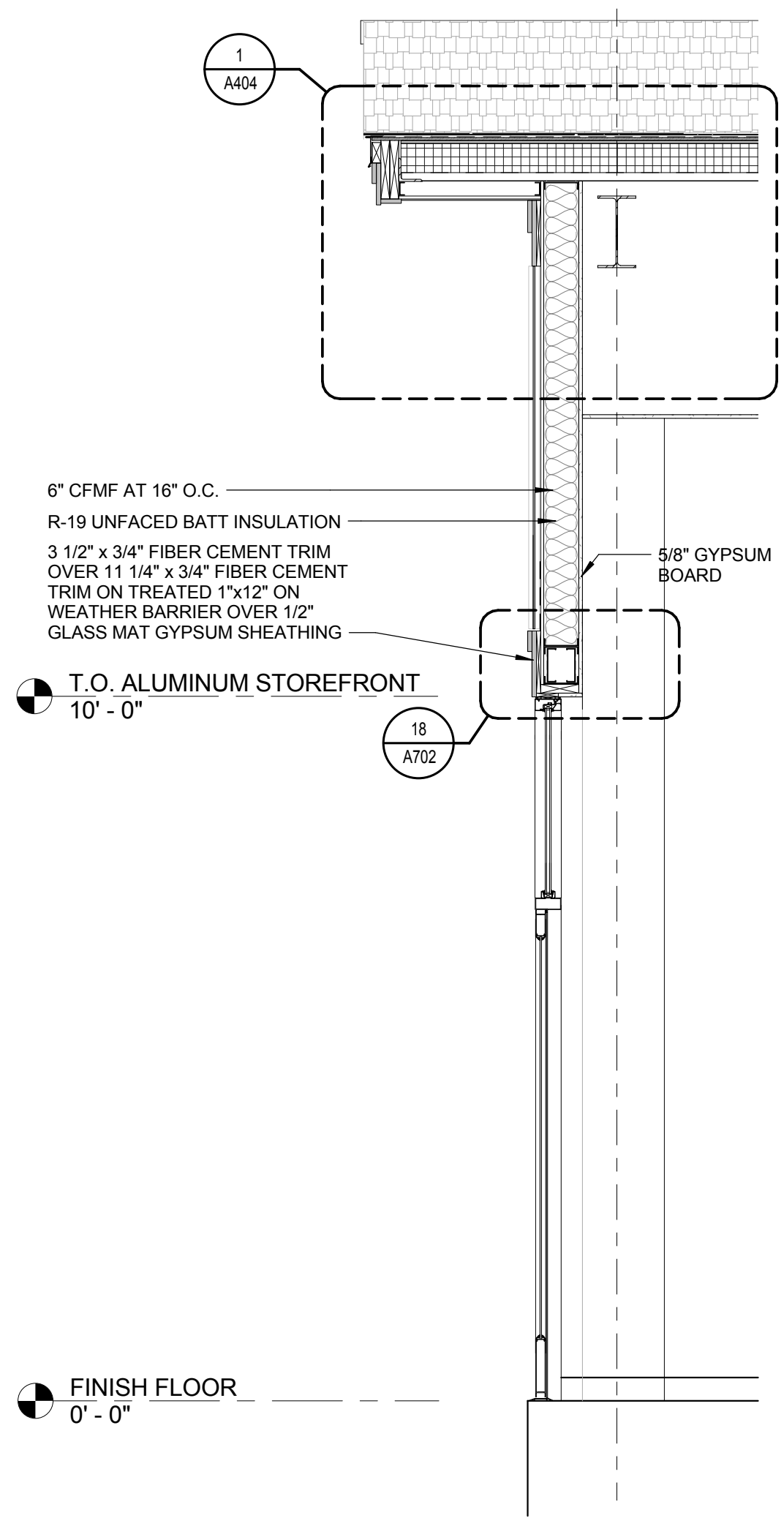

4 | WALL SECTION
SCALE: 1/2" = 1'-0"

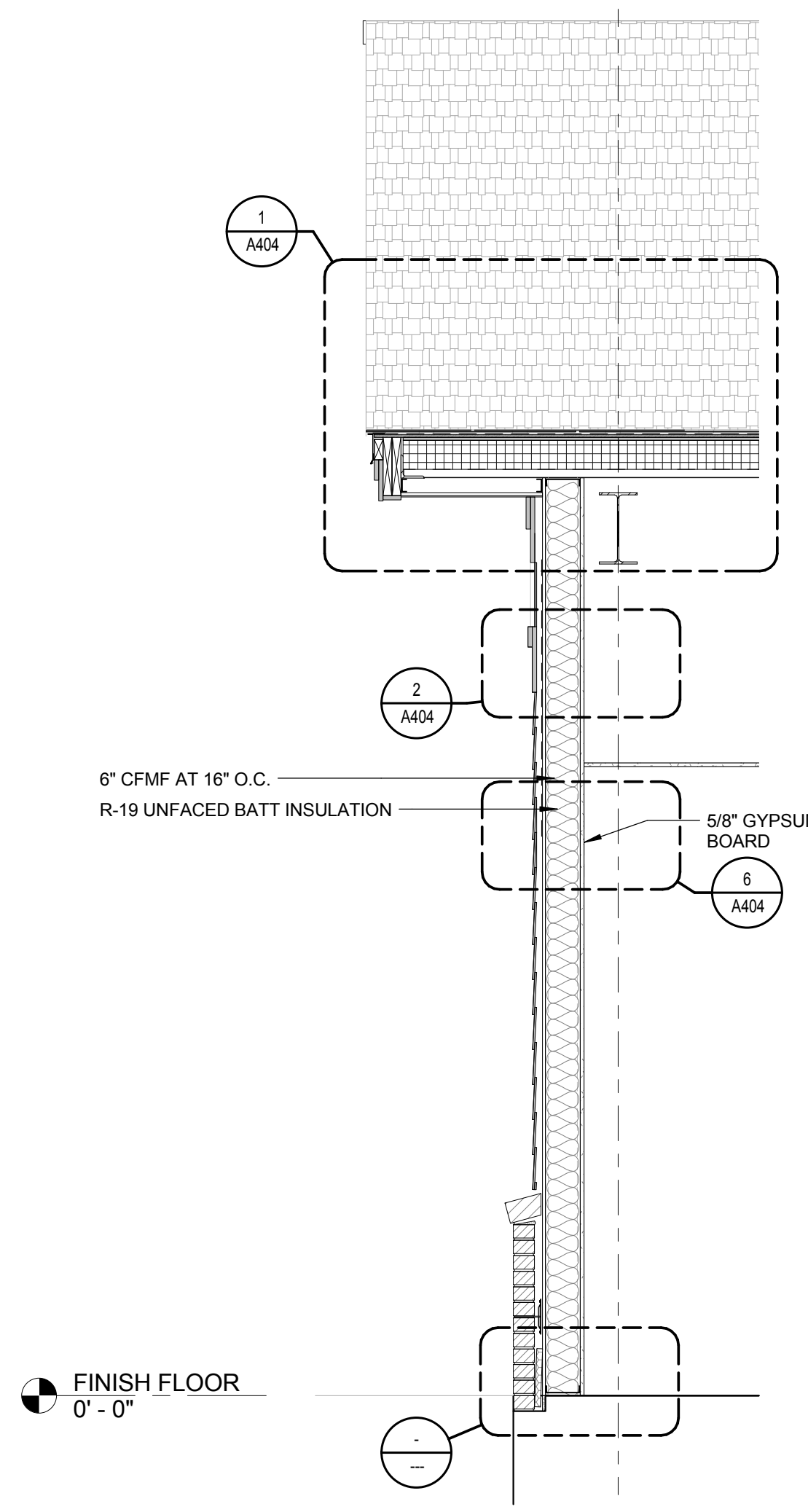

5 | WALL SECTION
SCALE: 1/2" = 1'-0"

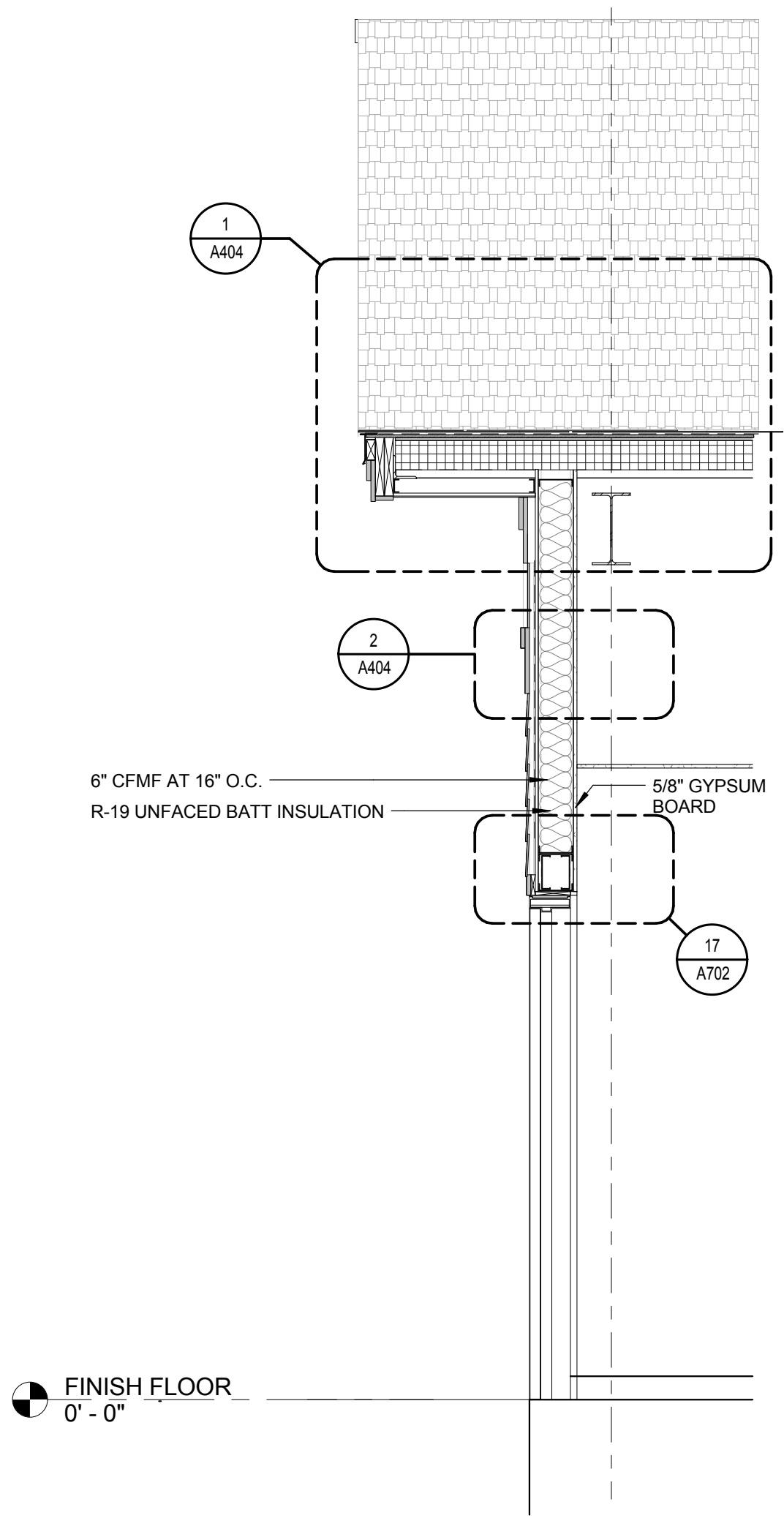

3 | WALL SECTION
SCALE: 1/2" = 1'-0"

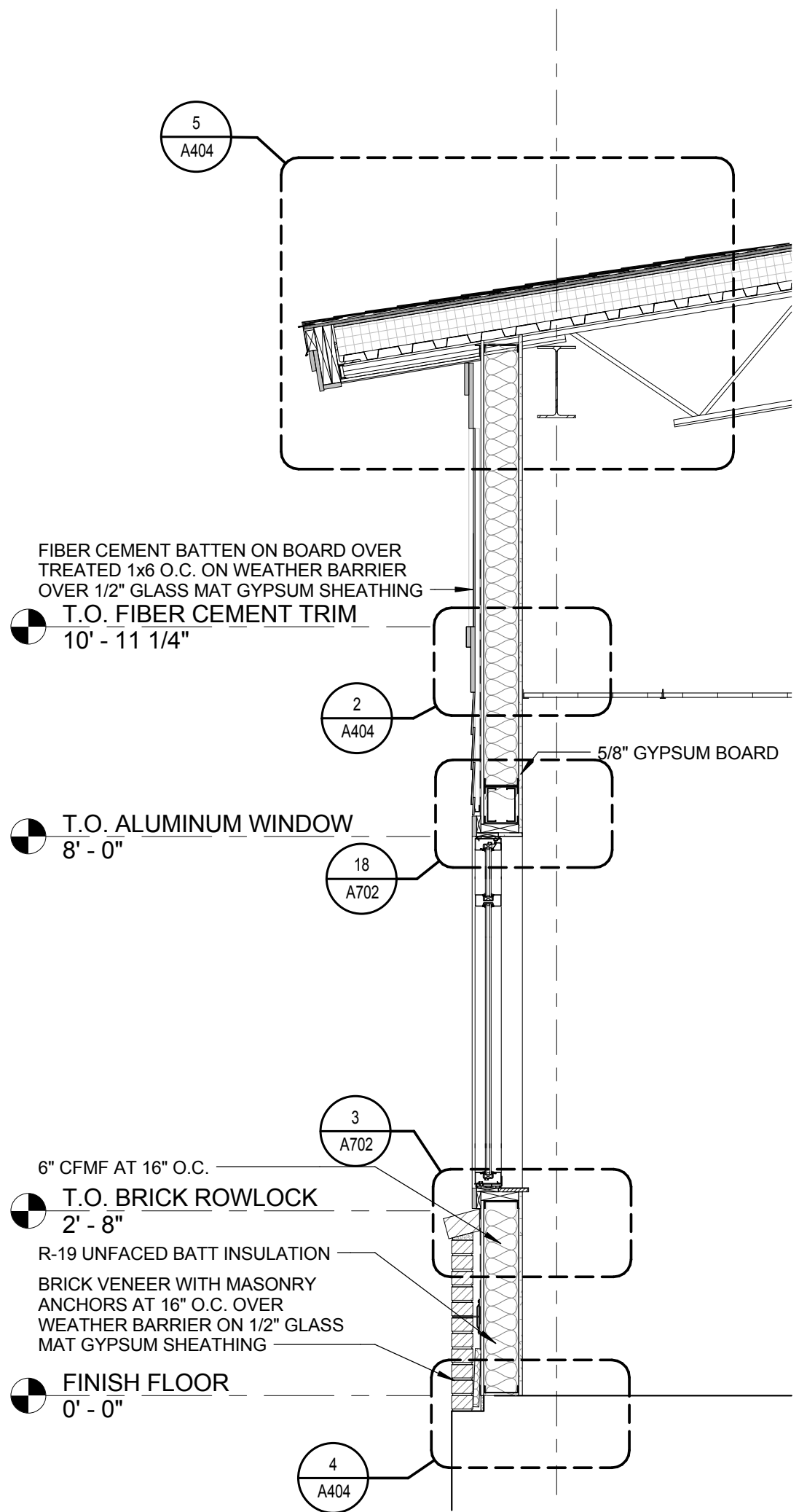

2 | WALL SECTION
SCALE: 1/2" = 1'-0"

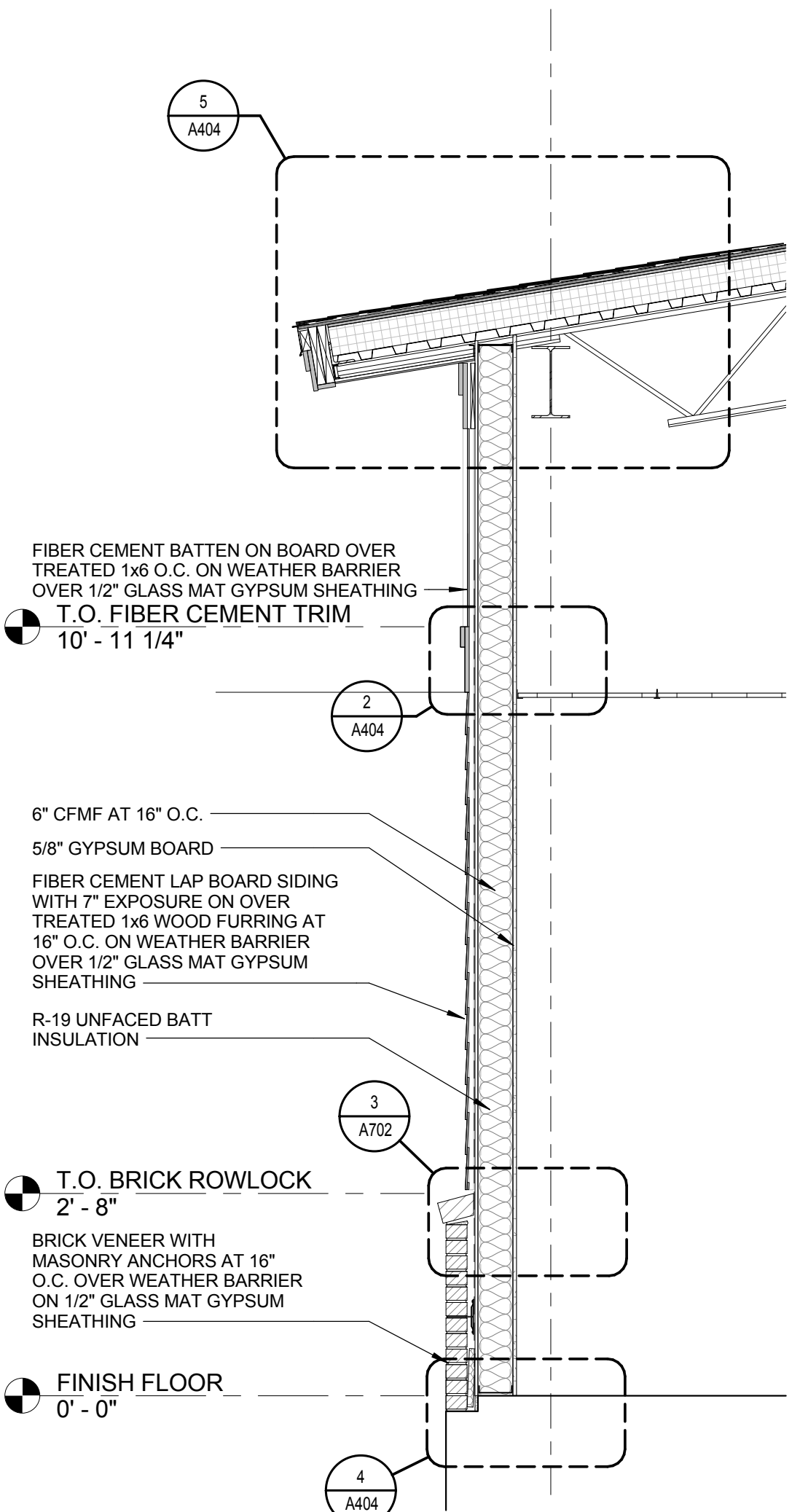

1 | WALL SECTION
SCALE: 1/2" = 1'-0"



Boucher Design Group LLC
Members A.I.A.
6802 Maple Ridge, Suite 200
Bellaire, Texas 77401
Tel. 713.785.3644
www.bdgap.com

This document is an instrument of service protected by the copyright law of the United States of America, 17 U.S.C §102, and shall not be copied or reproduced without the express written consent of Boucher Design Group, LLC. 2016

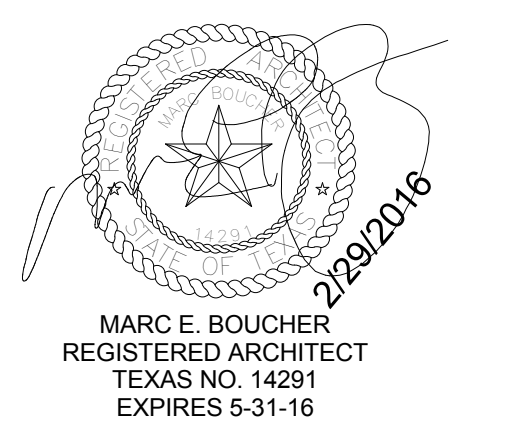

BAYSIDE COMMUNITY CENTER
BACLIFF, TEXAS
GALVESTON COUNTY

DATE	02/29/2016
PROJECT NO.	1409000
DRAWN BY	BW
CHECKED BY	BPA

WALL SECTIONS

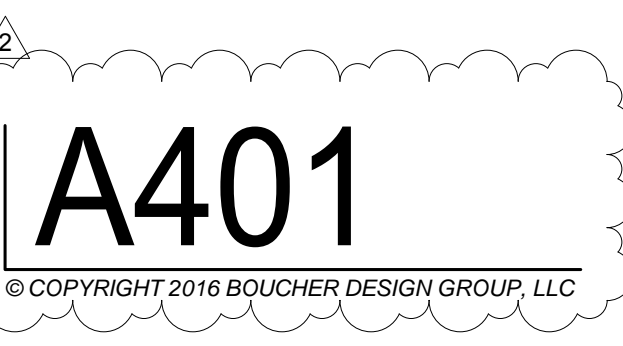

8/9/2016 10:29:22 AM

ISSUE	DATE	DESCRIPTION
2	03/08/16	ADD ARCHITECTURE



Boucher Design Group LLC
Members A.I.A.
6802 Mapleridge, Suite 200
Bellaire, Texas 77401
Tel. 713.785.3644
www.bdgap.com

This document is an instrument of service protected by the copyright law of the United States of America, 17 U.S.C §102, and shall not be copied or reproduced without the express written consent of Boucher Design Group, LLC. 2016

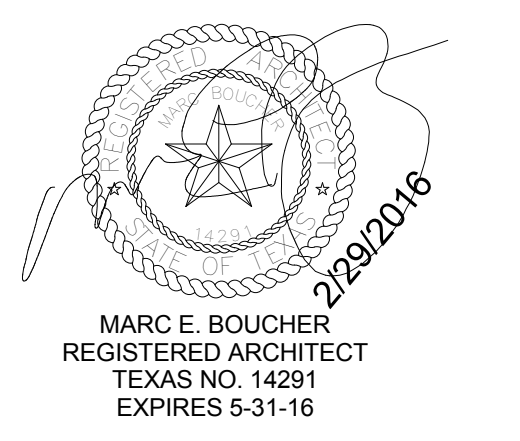

BAYSIDE COMMUNITY CENTER
BACLIFF, TEXAS
GALVESTON COUNTY

DATE	02/29/2016
PROJECT NO.	1409000
DRAWN BY	BW
CHECKED BY	BPA

WALL SECTIONS

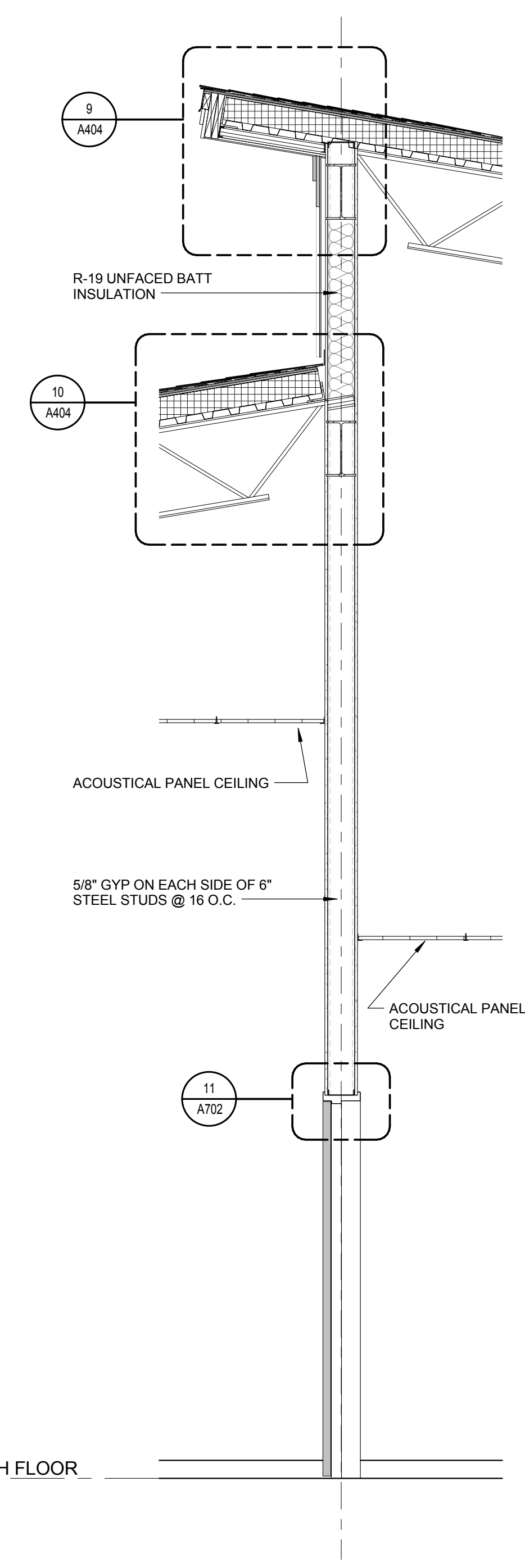

1 | WALL SECTION
SCALE: 1/2" = 1'-0"

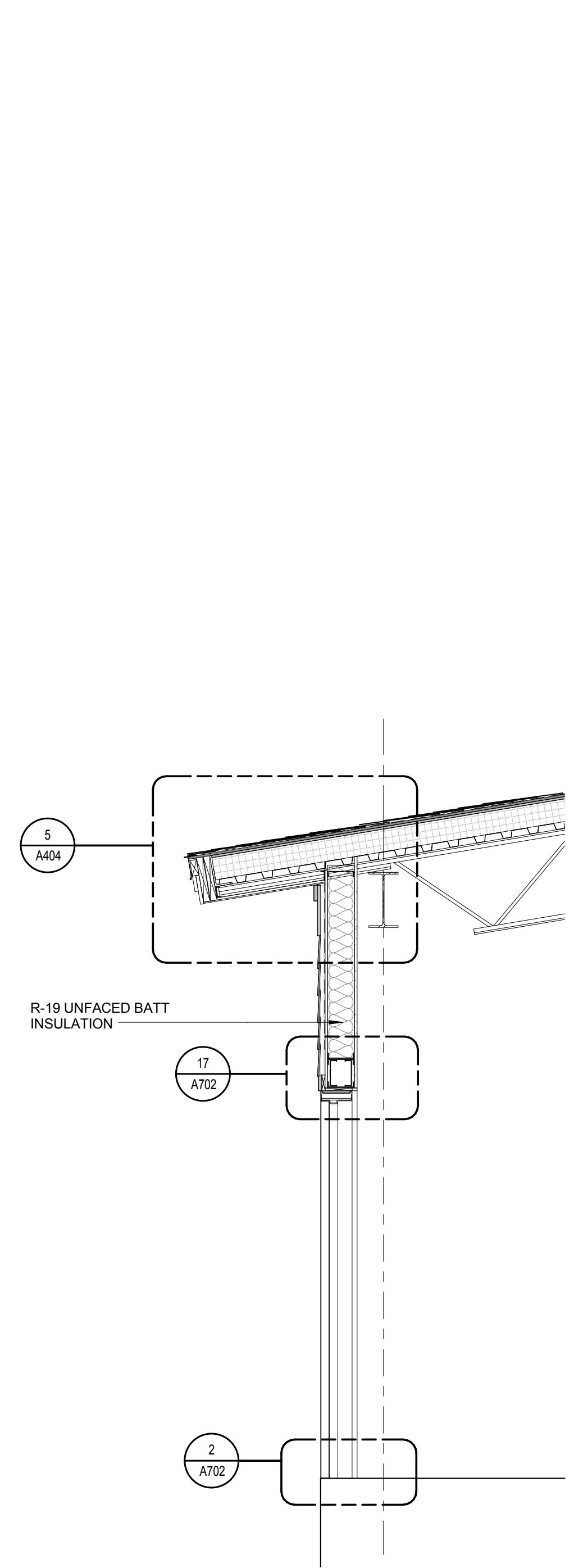

2 | WALL SECTION
SCALE: 1/2" = 1'-0"

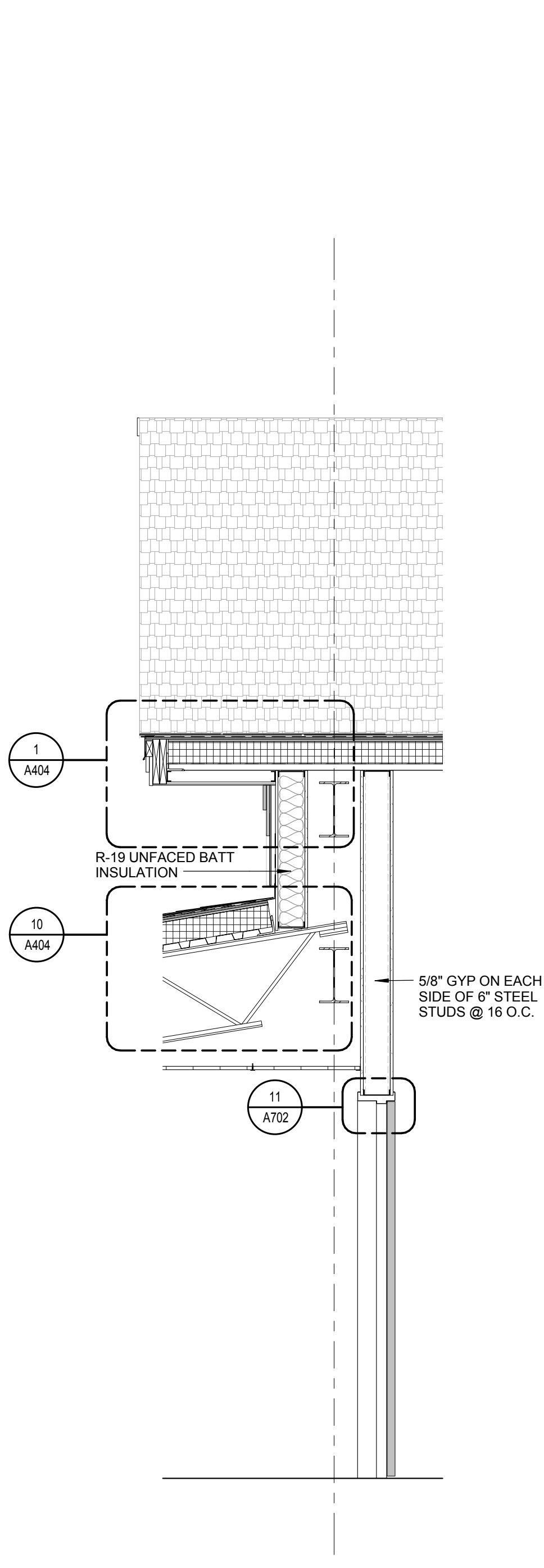

3 | WALL SECTION
SCALE: 1/2" = 1'-0"

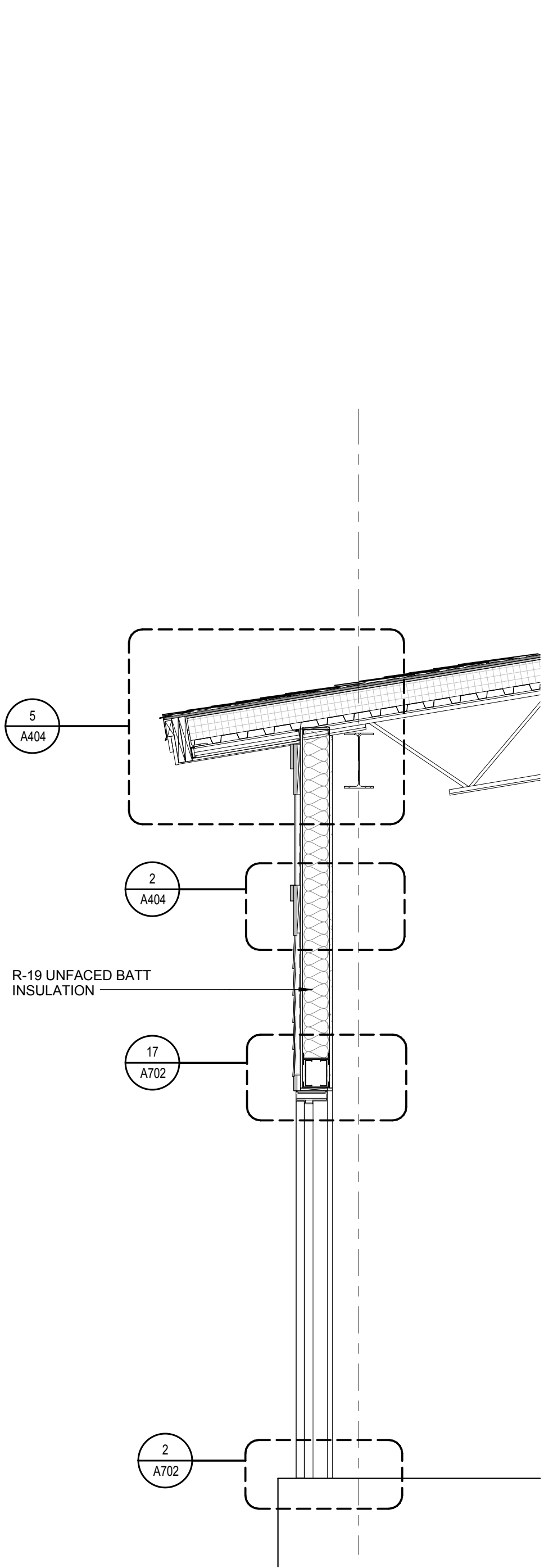

4 | WALL SECTION
SCALE: 1/2" = 1'-0"

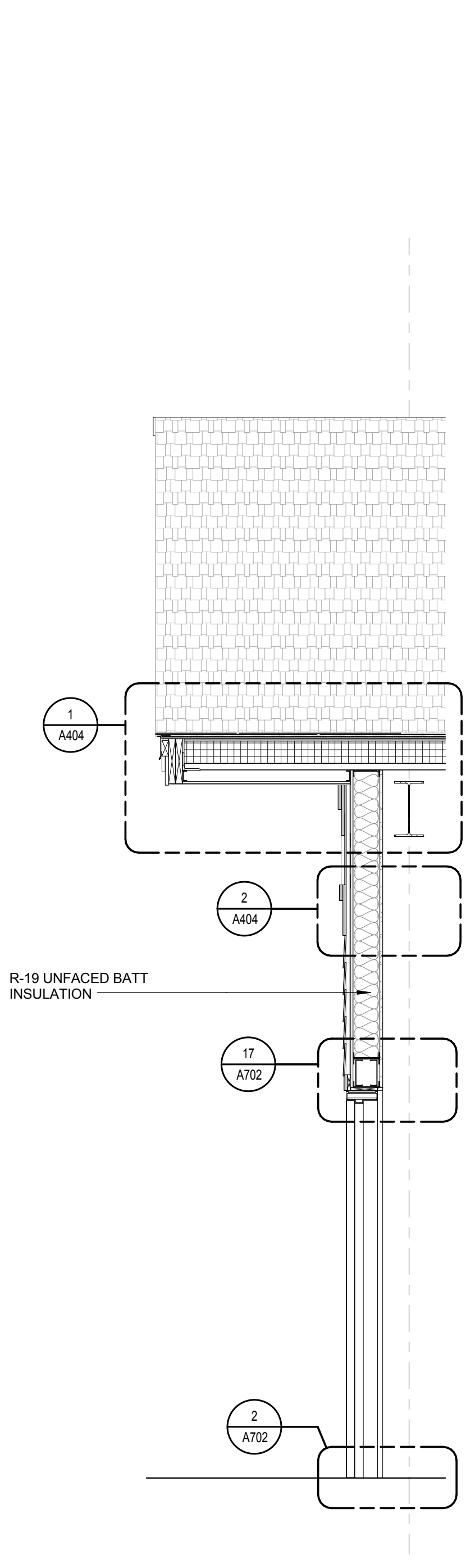

5 | WALL SECTION
SCALE: 1/2" = 1'-0"



C:\Users\stian\Documents\REVIT PROJECTS\1409000_GALVESTON COMMUNITY CENTER_brian.rvt

6/9/2016 10:29:24 AM

ISSUE	DATE	DESCRIPTION
3	5/16/16	VALUE ENGINEERING

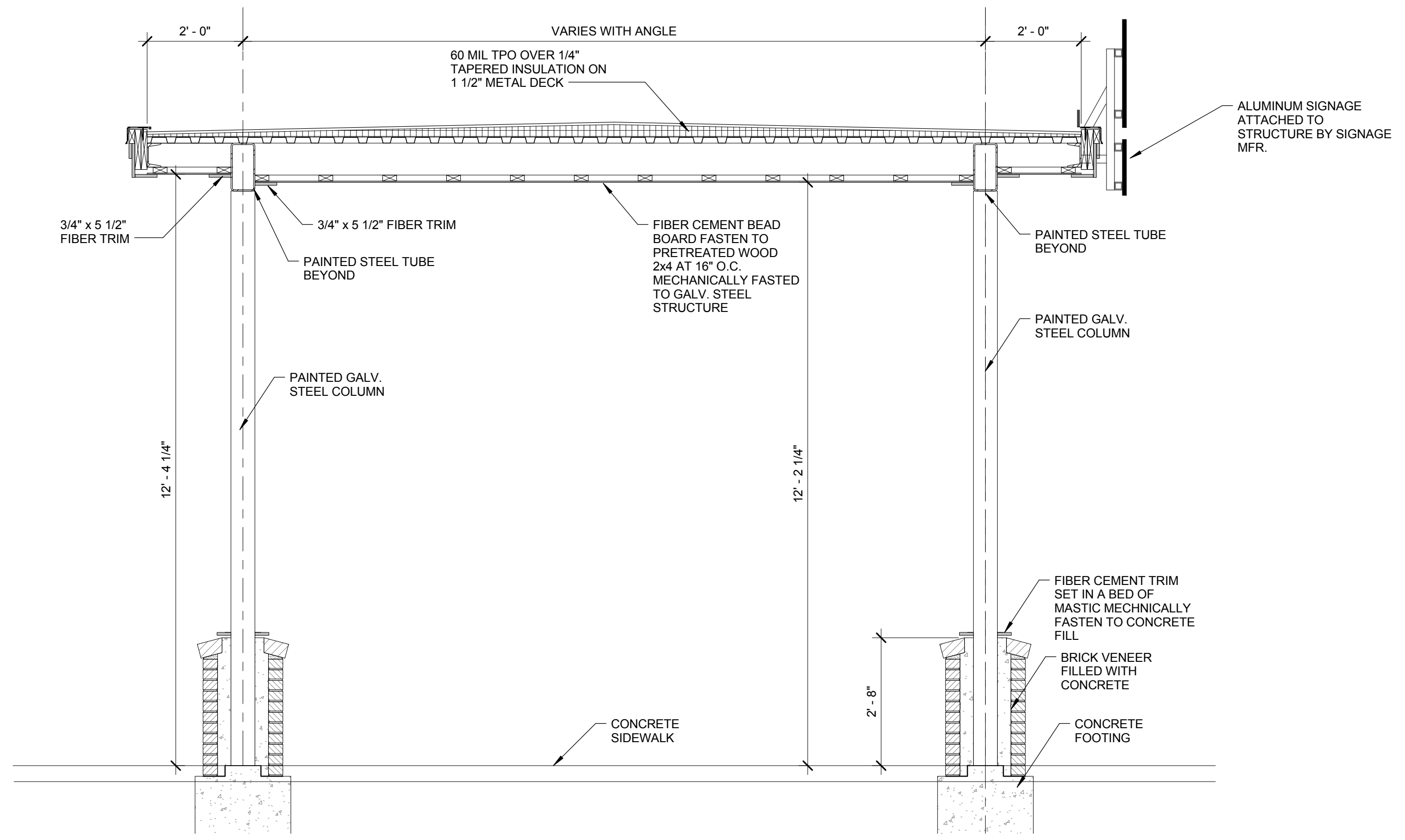

2 | CANOPY SECTION

SCALE: 1/2" = 1'-0"

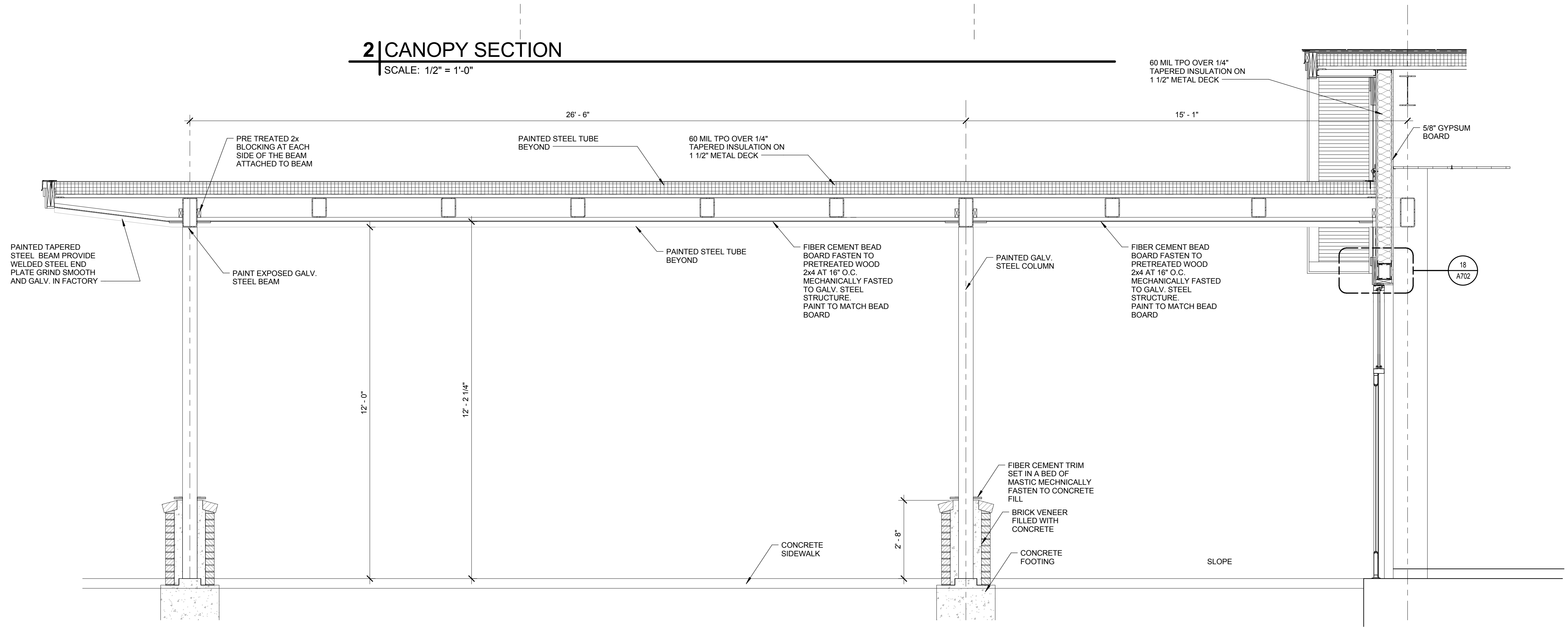

1 | CANOPY SECTION

SCALE: 1/2" = 1'-0"



Boucher Design Group LLC
Members A.I.A.
6802 Mapleridge, Suite 200
Bellaire, Texas 77401
Tel. 713.785.3644
www.bdgap.com

This document is an instrument of service protected by the copyright law of the United States of America, 17 U.S.C §102, and shall not be copied or reproduced without the express written consent of Boucher Design Group, LLC. 2016

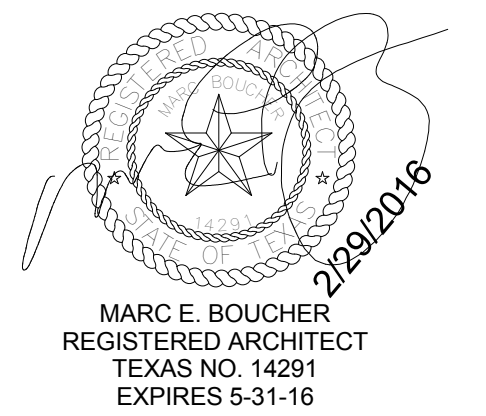

BAYSIDE COMMUNITY CENTER
BACLIFF, TEXAS
GALVESTON COUNTY

DATE	05/12/16
PROJECT NO.	1409000
DRAWN BY	BPA
CHECKED BY	BPA

WALL SECTIONS

A403
© COPYRIGHT 2016 BOUCHER DESIGN GROUP, LLC

ISSUE	DATE	DESCRIPTION
2	03/08/16	ADD ARCHITECTURE

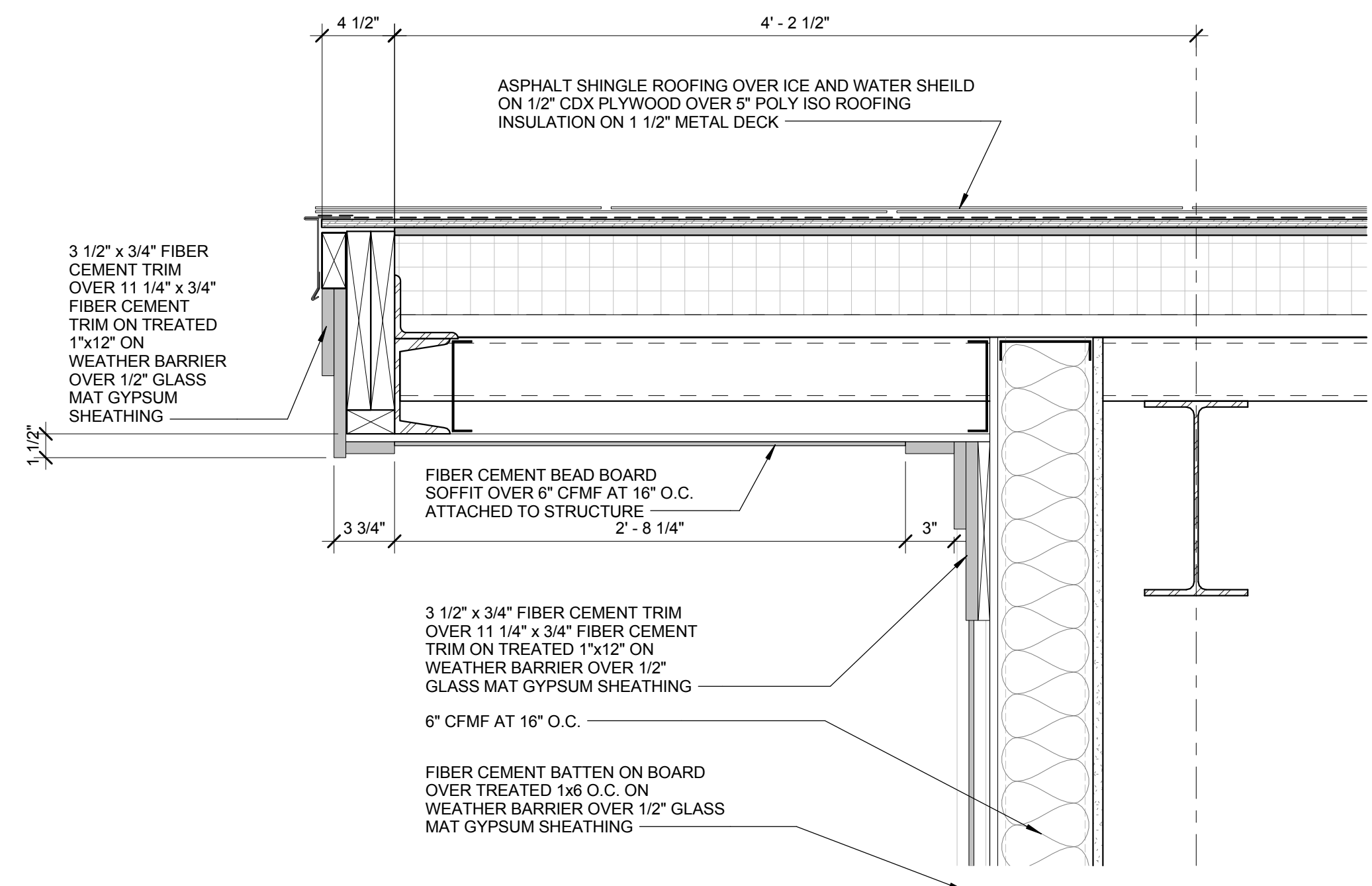

1 SECTION DETAIL

SCALE: 1 1/2" = 1'-0"

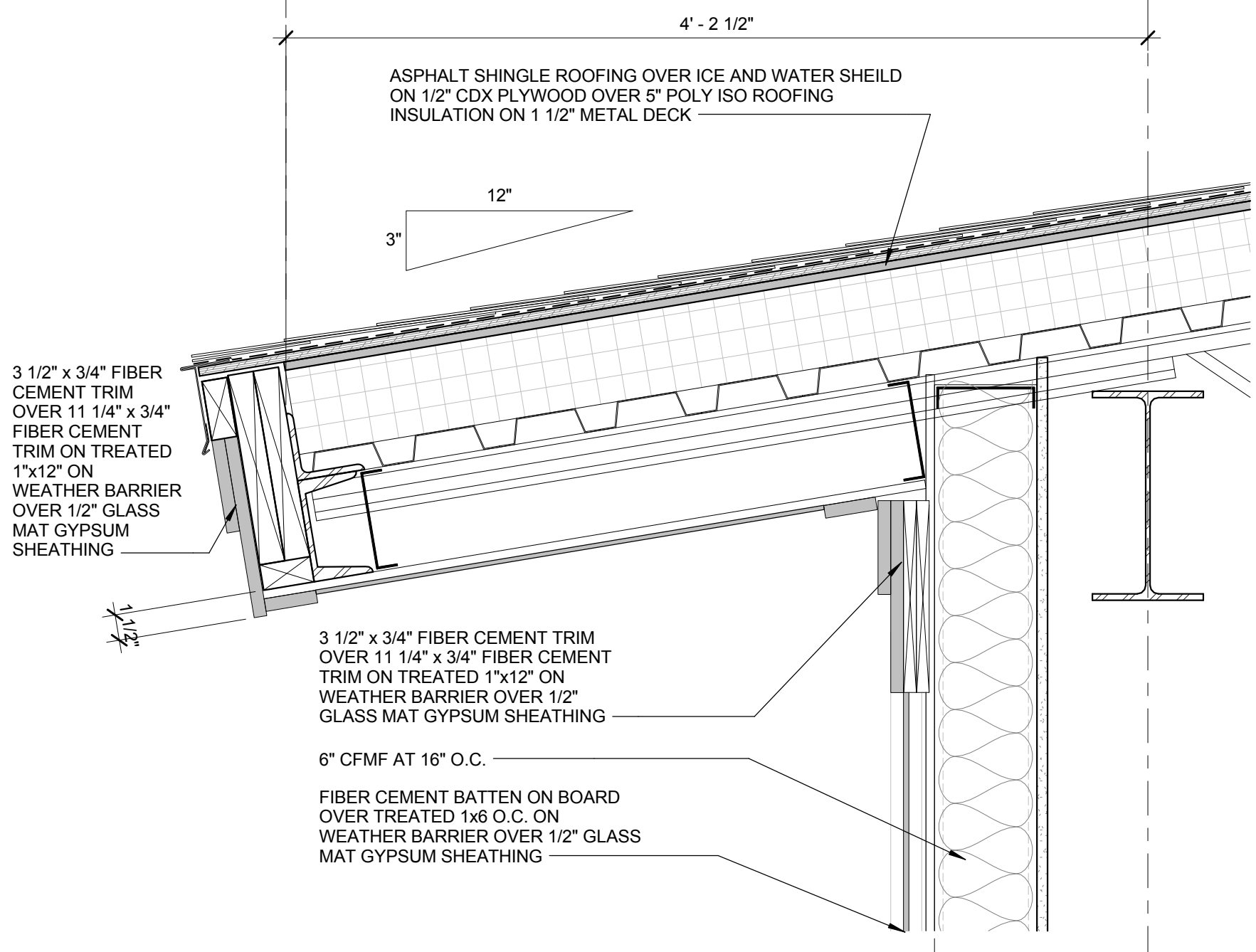

5 SECTION DETAIL

SCALE: 1 1/2" = 1'-0"

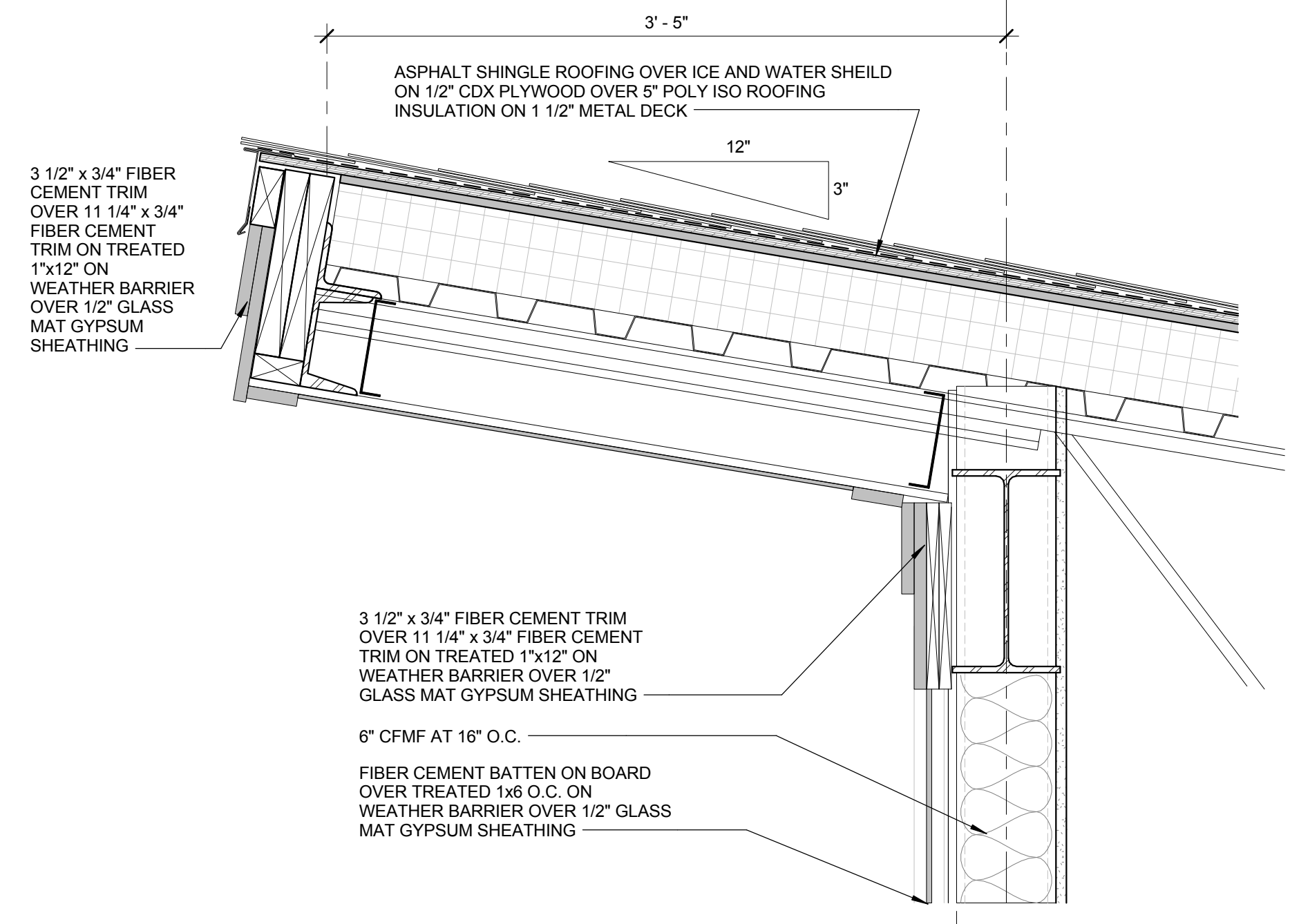

9 SECTION DETAIL

SCALE: 1 1/2" = 1'-0"

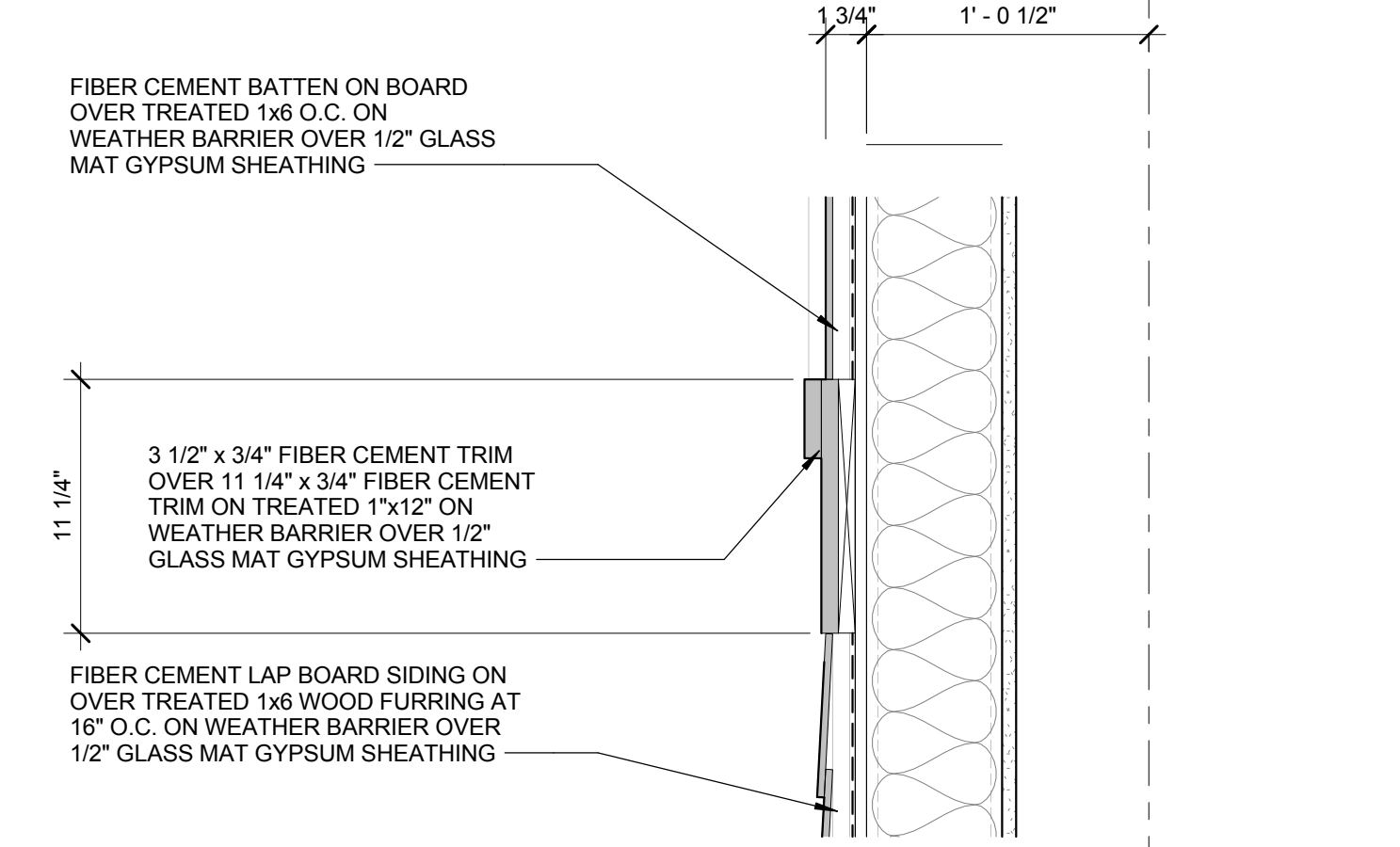

2 SECTION DETAIL

SCALE: 1 1/2" = 1'-0"

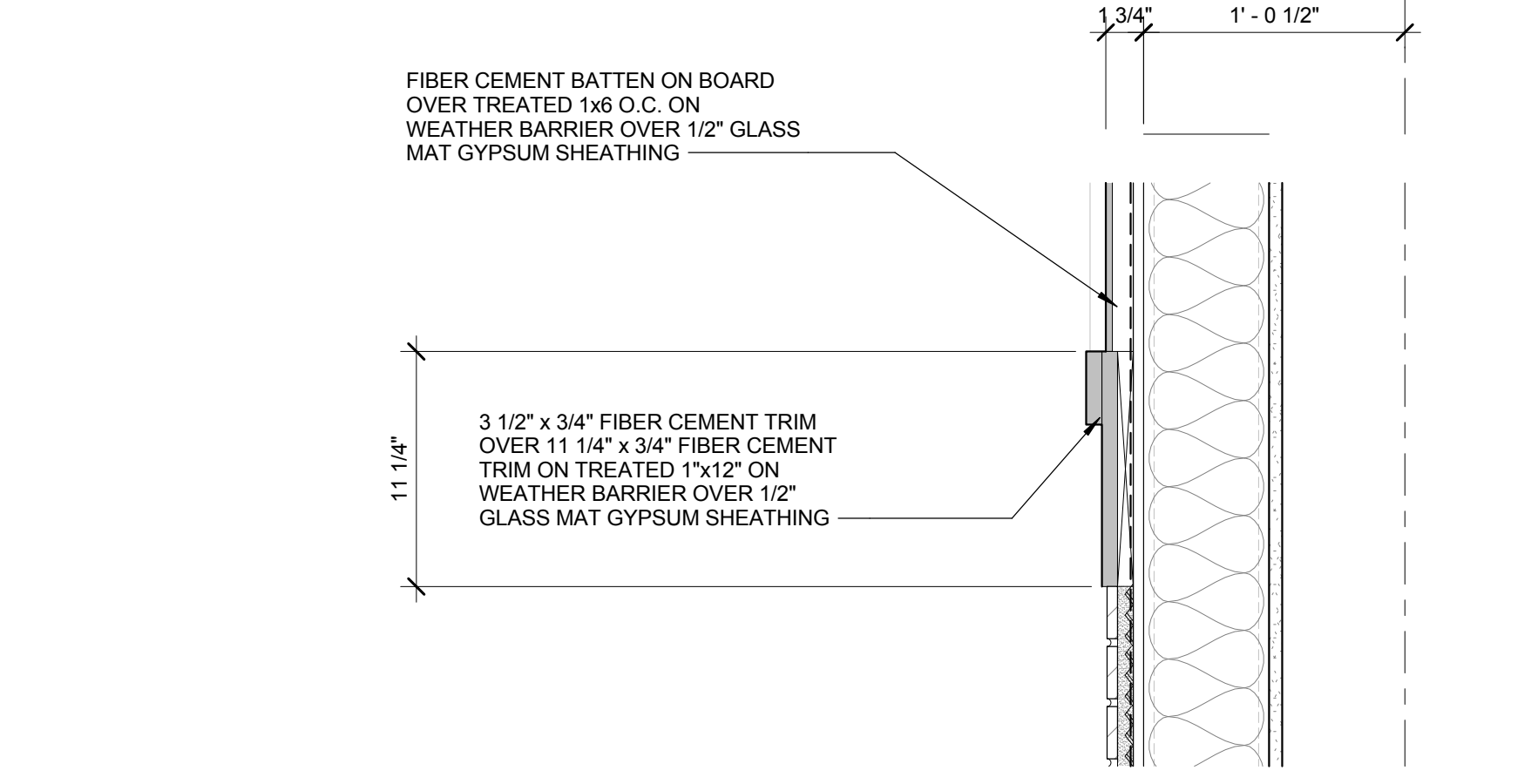

6 SECTION DETAIL

SCALE: 1 1/2" = 1'-0"

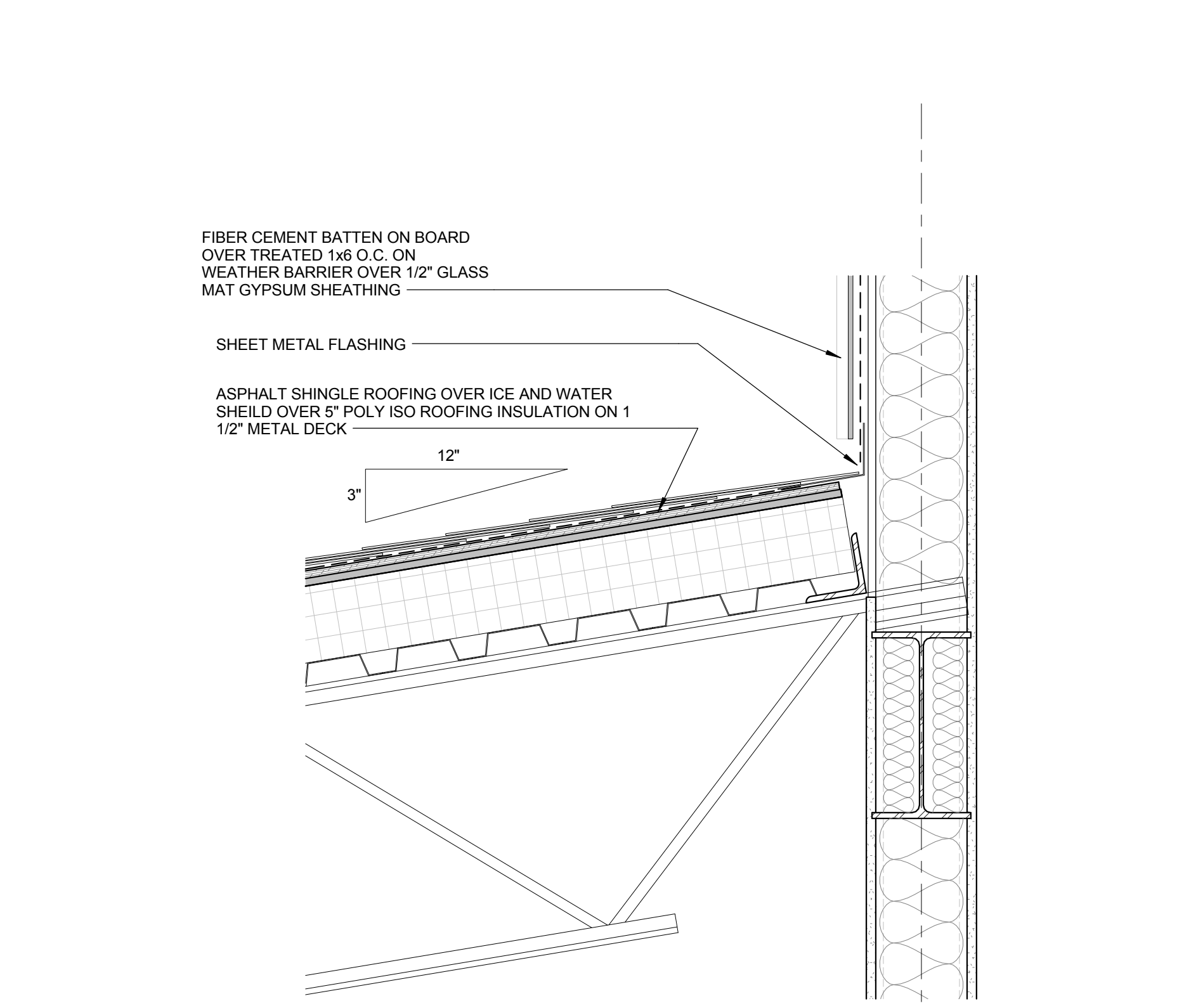

10 SECTION DETAIL

SCALE: 1 1/2" = 1'-0"

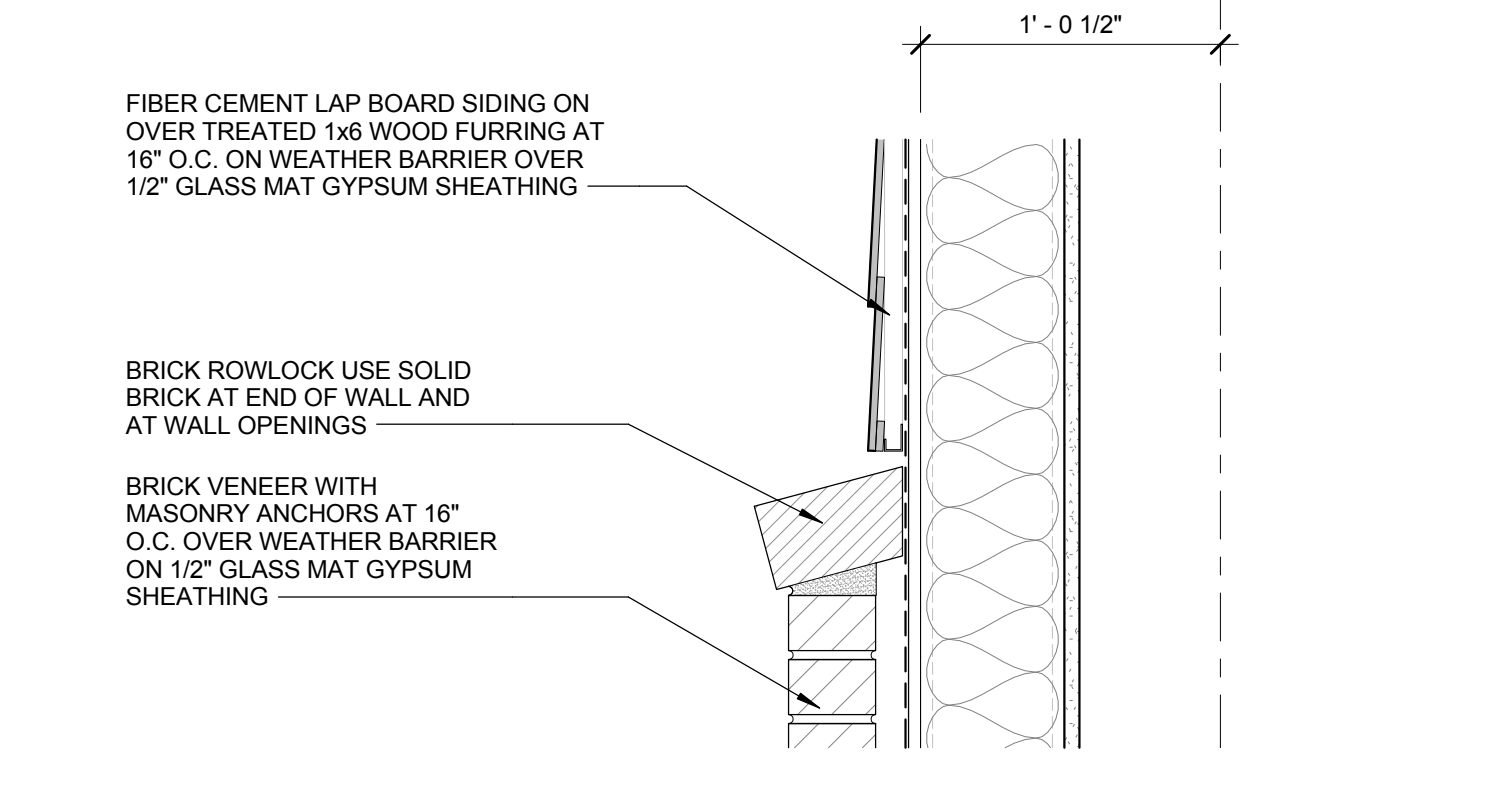

3 SECTION DETAIL

SCALE: 1 1/2" = 1'-0"

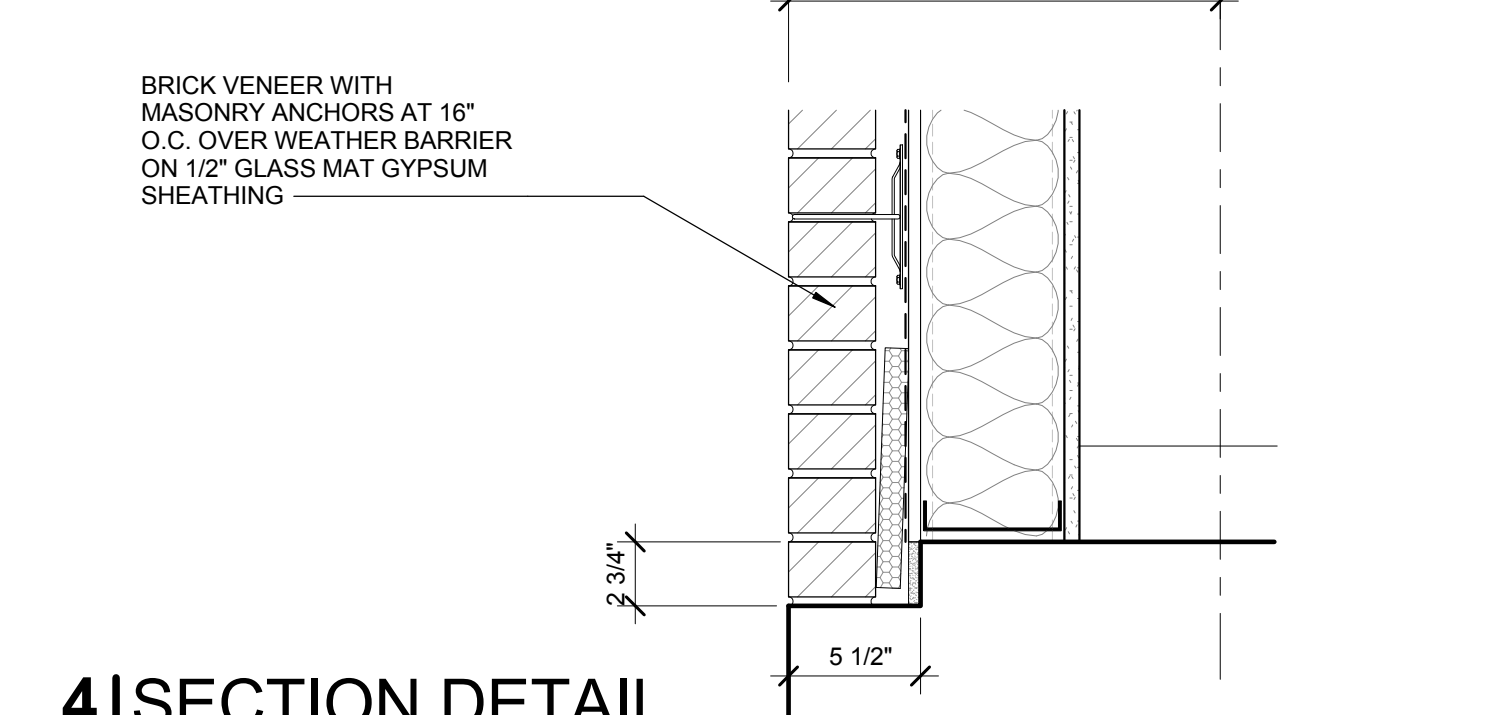

4 SECTION DETAIL

SCALE: 1 1/2" = 1'-0"



Boucher Design Group LLC
Members A.I.A.
6802 Mapleridge, Suite 200
Bellaire, Texas 77401
Tel. 713.785.3644
www.bdgap.com

This document is an instrument of service protected by the copyright law of the United States of America, 17 U.S.C §102, and shall not be copied or reproduced without the express written consent of Boucher Design Group, LLC. 2016

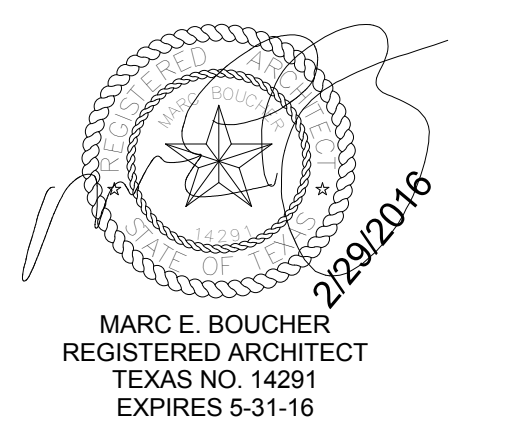

BAYSIDE COMMUNITY CENTER
BACLIFF, TEXAS
GALVESTON COUNTY

DATE	02/29/16
PROJECT NO.	1409000
DRAWN BY	BPA
CHECKED BY	BPA

SECTION DETAILS

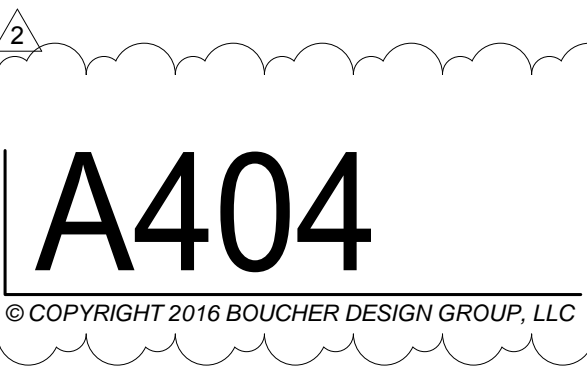

C:\Users\stran\Documents\REVIT PROJECTS\1409000_GALVESTON COMMUNITY CENTER_bdm.rvt 6/9/2016 10:29:29 AM

ISSUE	DATE	DESCRIPTION
3	5/16/16	VALUE ENGINEERING

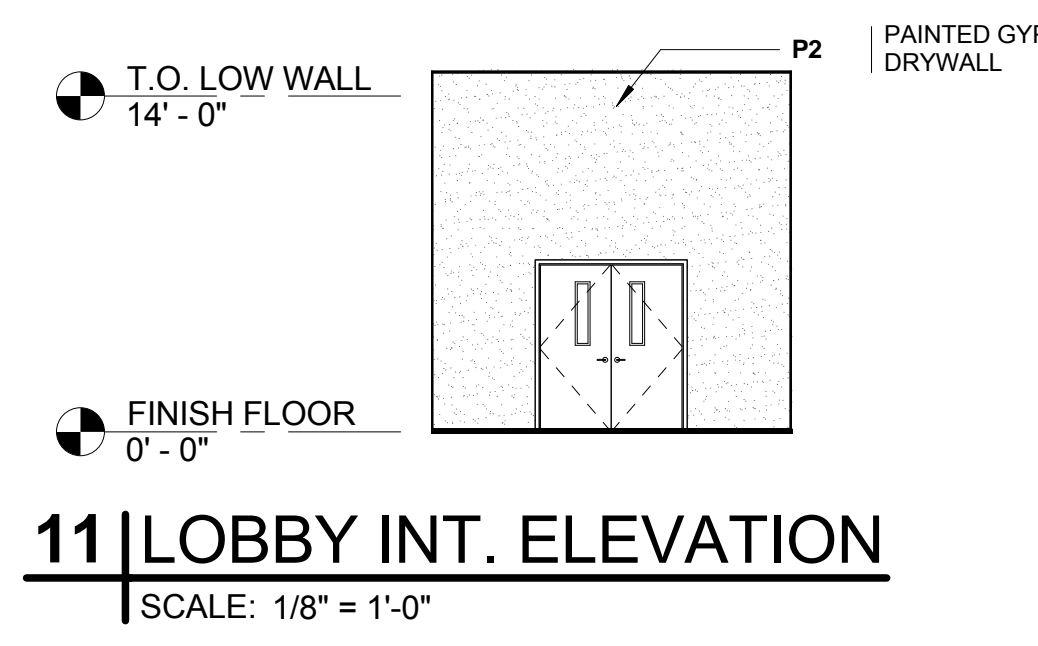

11 | LOBBY INT. ELEVATION
SCALE: 1/8" = 1'-0"

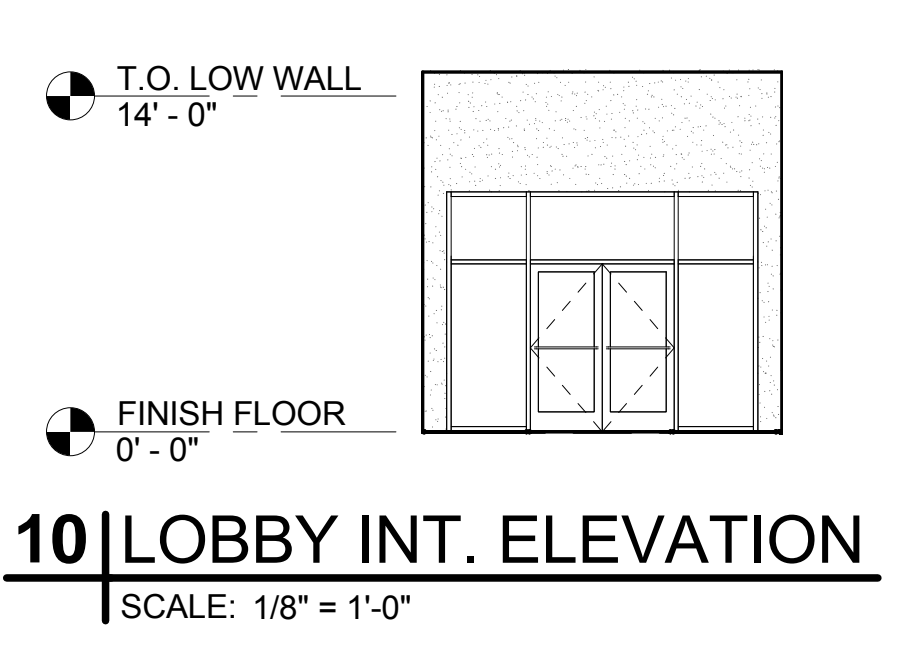

10 | LOBBY INT. ELEVATION
SCALE: 1/8" = 1'-0"

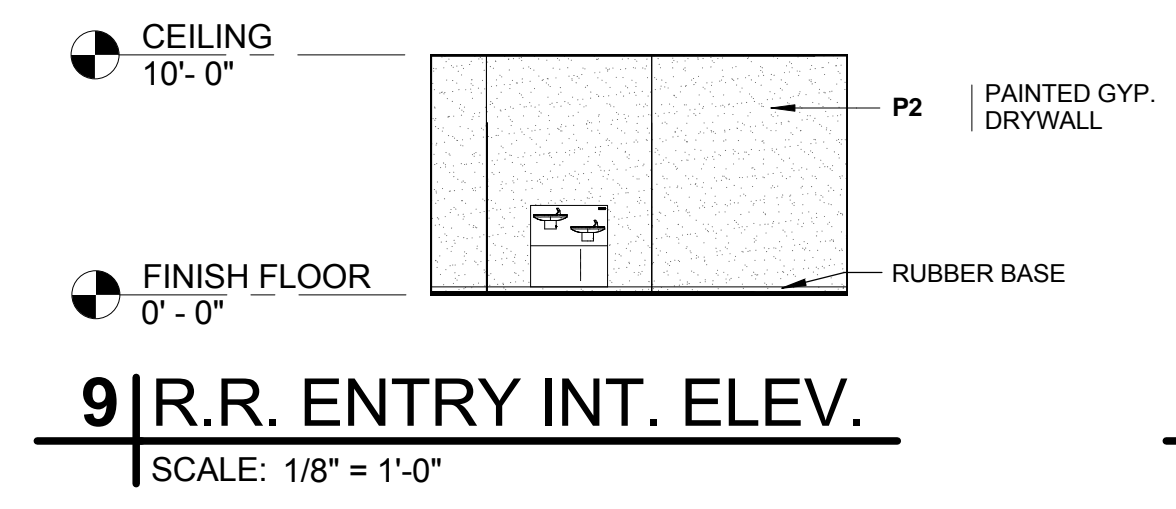

9 | R.R. ENTRY INT. ELEV.
SCALE: 1/8" = 1'-0"

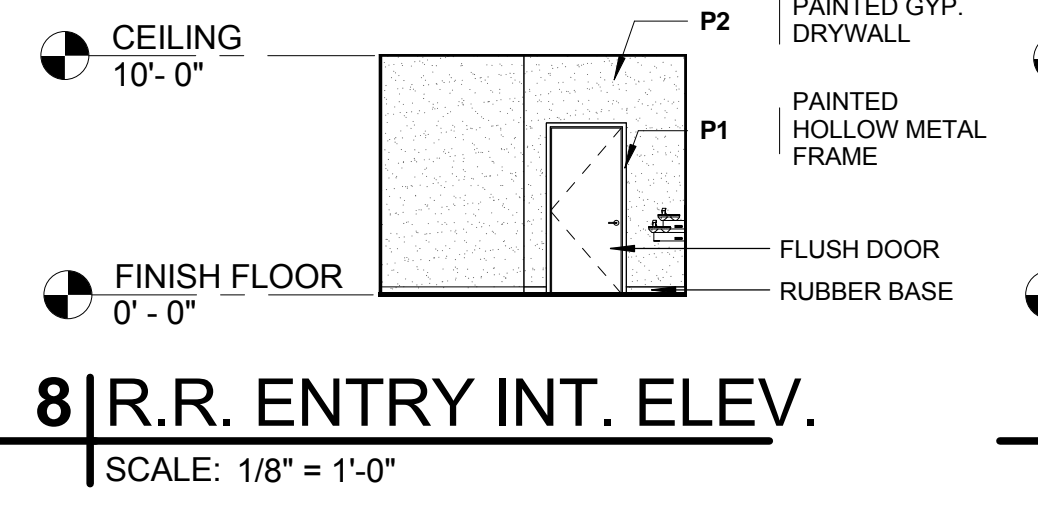

8 | R.R. ENTRY INT. ELEV.
SCALE: 1/8" = 1'-0"

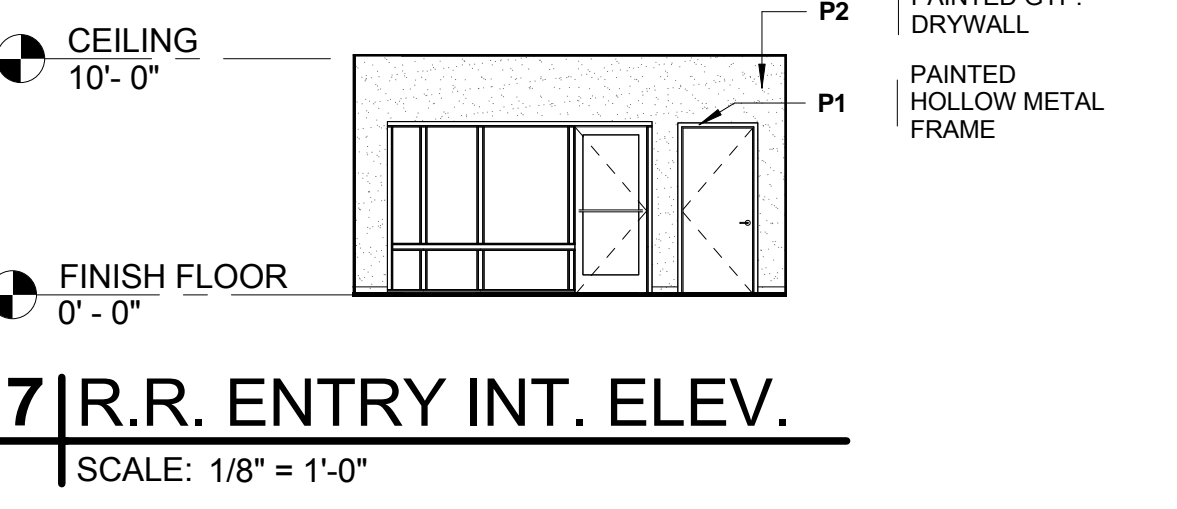

7 | R.R. ENTRY INT. ELEV.
SCALE: 1/8" = 1'-0"

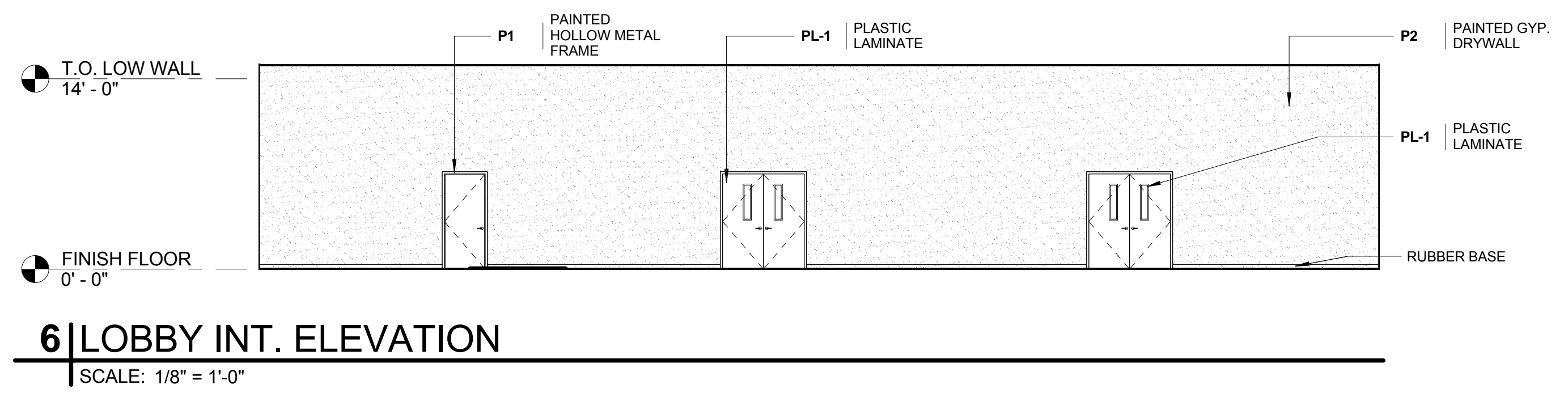

6 | LOBBY INT. ELEVATION
SCALE: 1/8" = 1'-0"

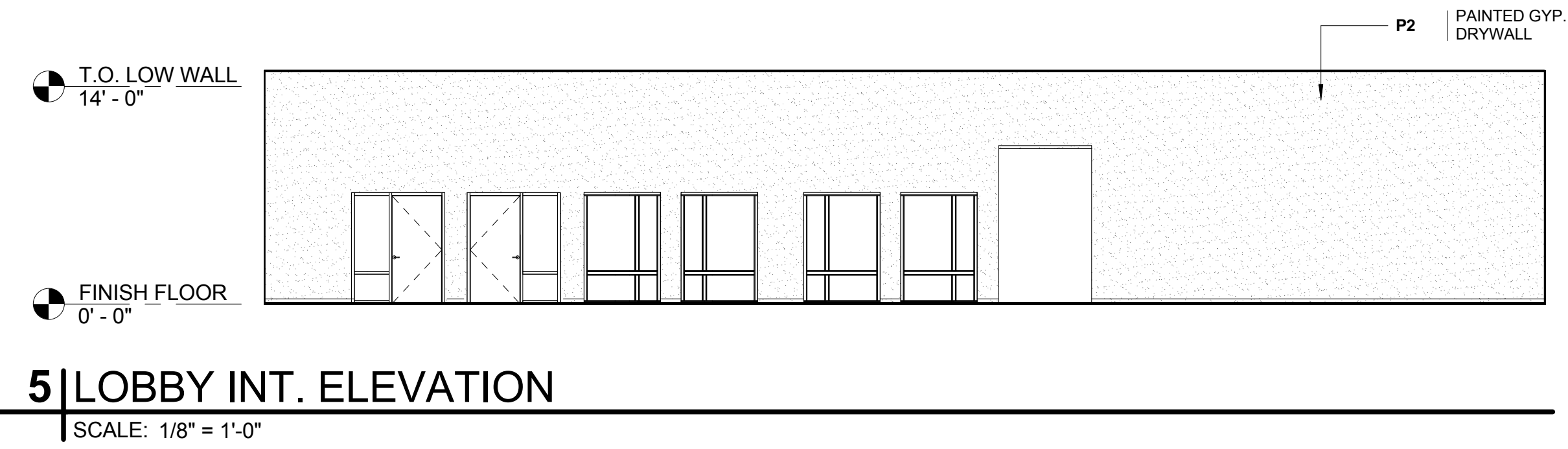

5 | LOBBY INT. ELEVATION
SCALE: 1/8" = 1'-0"

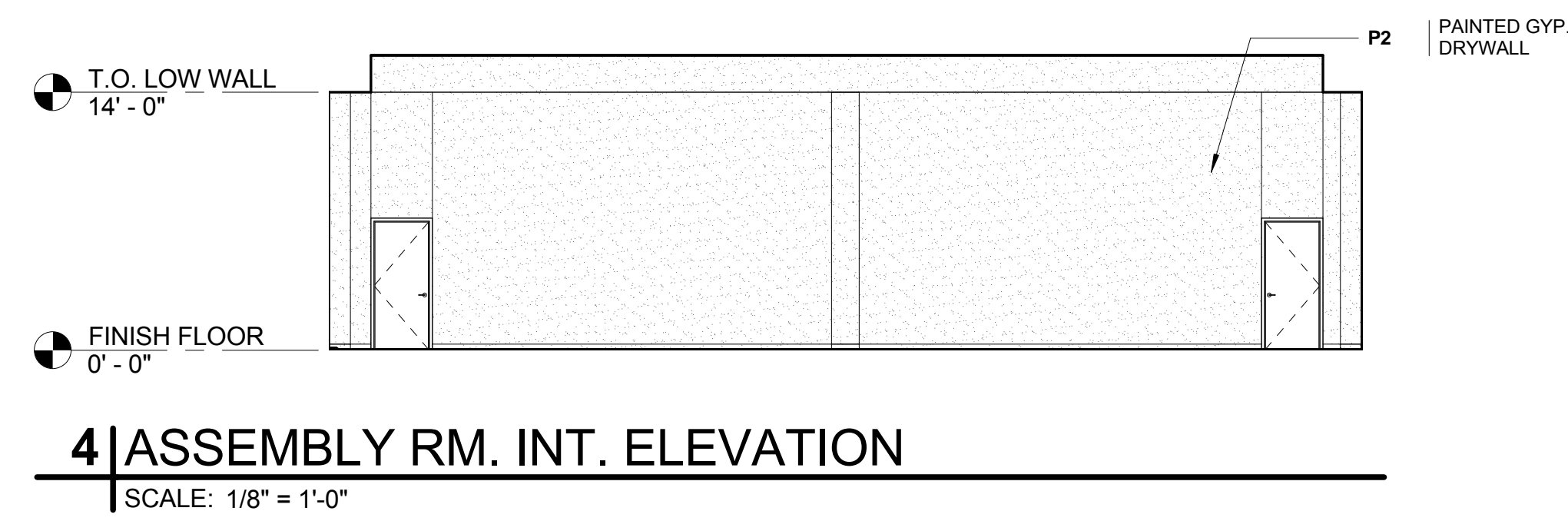

4 | ASSEMBLY RM. INT. ELEVATION
SCALE: 1/8" = 1'-0"

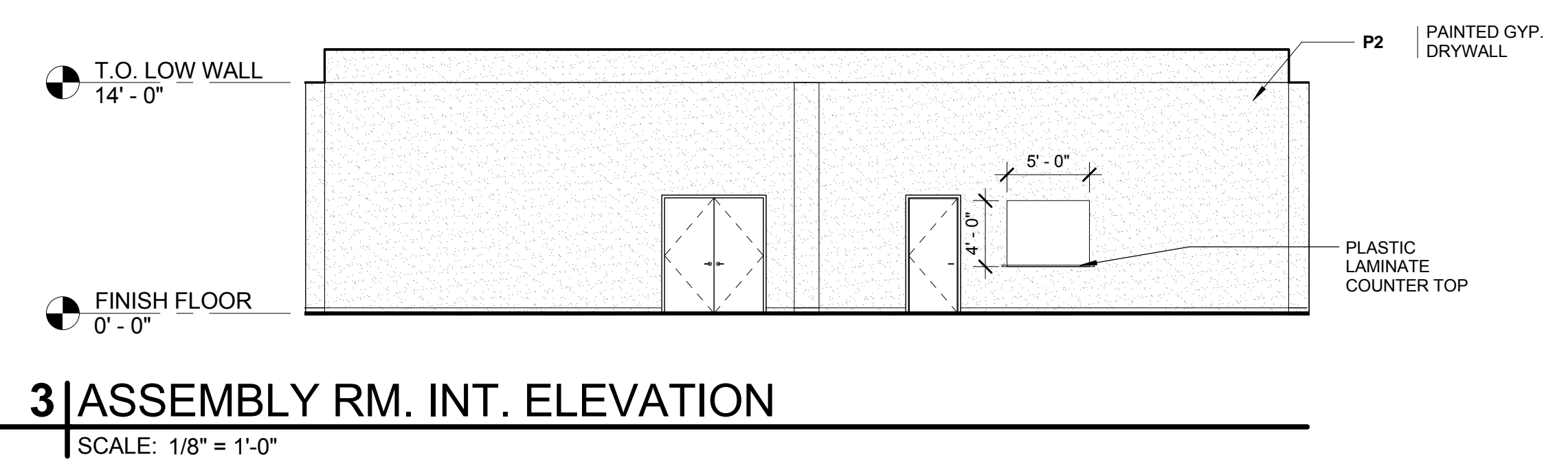

3 | ASSEMBLY RM. INT. ELEVATION
SCALE: 1/8" = 1'-0"

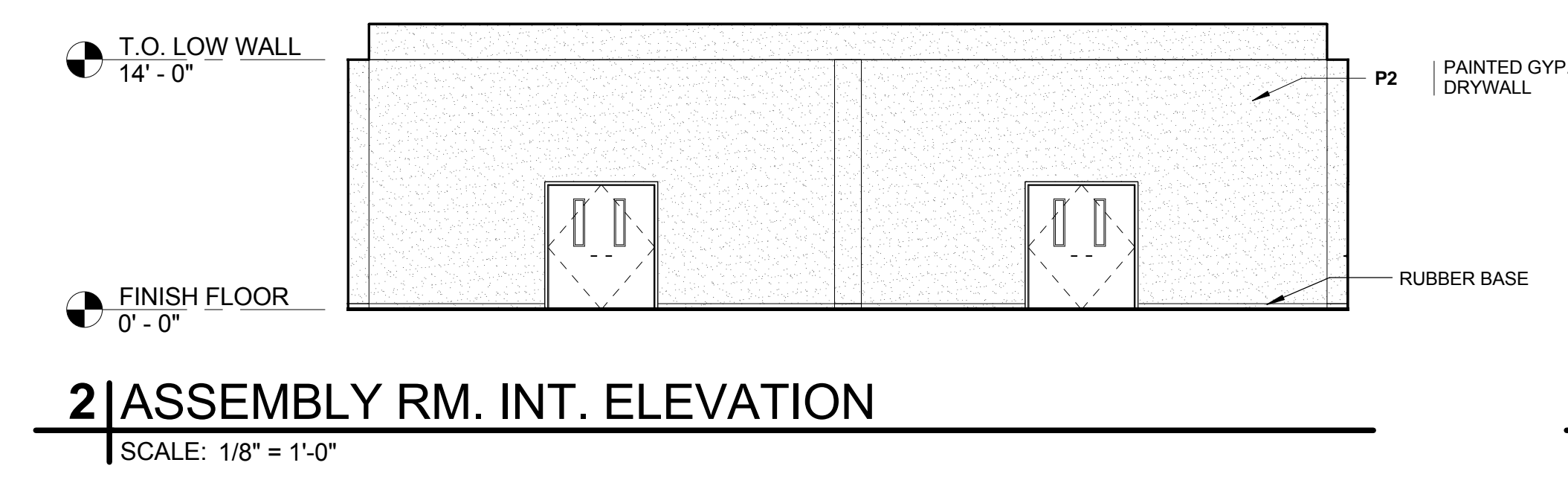

2 | ASSEMBLY RM. INT. ELEVATION
SCALE: 1/8" = 1'-0"

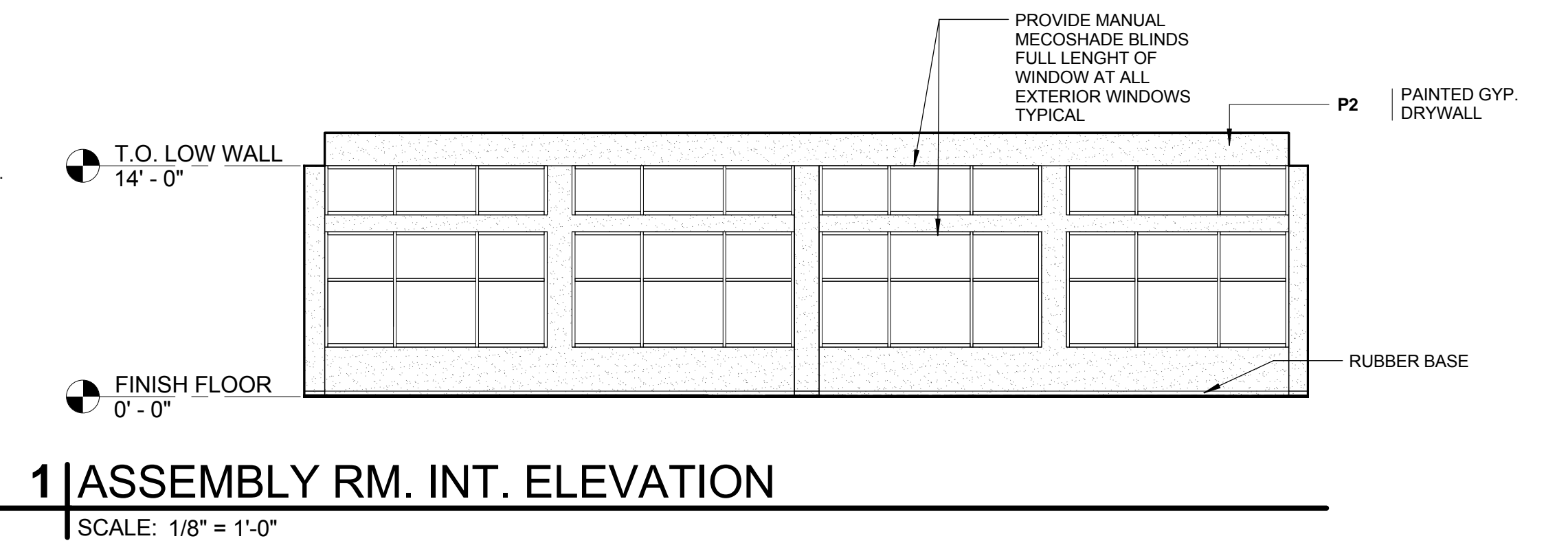

1 | ASSEMBLY RM. INT. ELEVATION
SCALE: 1/8" = 1'-0"

bdg
architecture
+ planning
boucher design group

Boucher Design Group LLC
Members A.I.A.
6802 Mapleridge, Suite 200
Bellaire, Texas 77401
Tel. 713.785.3644
www.bdgap.com

This document is an instrument of service protected by the copyright law of the United States of America, 17 U.S.C §102, and shall not be copied or reproduced without the express written consent of Boucher Design Group, LLC. 2016

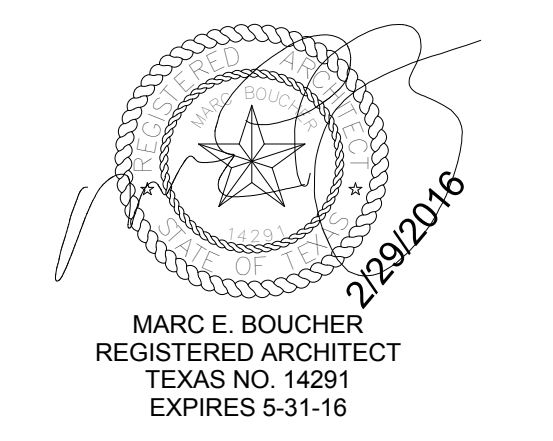

BAYSIDE COMMUNITY CENTER	
BACLIFF, TEXAS	
GALVESTON COUNTY	
DATE	08/15/08
PROJECT NO.	1409000
DRAWN BY	Author
CHECKED BY	Checker

INTERIOR ELEVATIONS

A600
© COPYRIGHT 2016 BOUCHER DESIGN GROUP, LLC

DOOR SCHEDULE

NO.	MATERIAL & TYPE	THK.	DOOR LOCATION		SIZE		ELEV.	FINISH	LABEL	FRAME			DETAILS			REMARKS	SIGNAGE	HARDWARE SET
			FROM	TO	WIDTH	HEIGHT				MAT.	FINISH	LABEL	HEAD	JAMB	SILL			
01	ALUM/GLASS	1 3/4"	LOBBY	EXTERIOR	6'-0"	7'-0"	E	ALUM.		ALUM			18/A702	13/A702	4/A702			SET # 01
02	HM/ P-LAM	1 3/4"	LOBBY	OFFICE	3'-2 3/4"	6'-11 3/4"	A	P-LAM		H.M.			16/A702	11/A702		A		
03	HM/ P-LAM	1 3/4"	CRAFTS RM.	CARD RM.	3'-0"	7'-0"	A	P-LAM	20 MINS	H.M.	20 MINS		16/A702	11/A702		A		
04	HM/ P-LAM	1 3/4"	LOBBY	CRAFTS RM.	3'-2 3/4"	6'-11 3/4"	A	P-LAM		H.M.			16/A702	11/A702		A		
05	HM/ P-LAM	1 3/4"	ASSEMBLY	LOBBY	6'-0"	7'-0"	D	P-LAM		H.M.			16/A702	11/A702		B		SET # 102
06	HM/ P-LAM	1 3/4"	ACT. STOR.	CRAFTS RM	3'-0"	7'-0"	A	P-LAM		H.M.			16/A702	11/A702		A		SET # 101
07	HM/ P-LAM	1 3/4"	JAN. CLOSET	LOBBY	3'-0"	7'-0"	A	P-LAM	20 MINS	H.M.	20 MINS		16/A702	11/A702		B		SET # 104
08	HM/ P-LAM	1 3/4"	EXERCISE RM.	LOBBY	3'-0"	7'-0"	A	P-LAM	20 MINS	H.M.	20 MINS		16/A702	11/A702	1/A702	B		SET # 101
09	HM/ P-LAM	1 3/4"	ASSEMBLY	LOBBY	6'-0"	7'-0"	D	P-LAM	20 MINS	H.M.	20 MINS		16/A702	11/A702		B		SET # 102
10	HM/ P-LAM	1 3/4"	WOMENS R.R.	LOBBY	3'-0"	7'-0"	A	P-LAM	20 MINS	H.M.	20 MINS		16/A702	11/A702		C		SET # 103
11	HM/ P-LAM	1 3/4"	MENS R.R.	LOBBY	3'-0"	7'-0"	A	P-LAM	20 MINS	H.M.	20 MINS		16/A702	11/A702		D		SET # 103
12	HM/ P-LAM	1 3/4"	DATA	LOBBY	3'-0"	7'-0"	A	P-LAM	20 MINS	H.M.	20 MINS		17/A702	12/A702		B		SET # 100
13	FRP	1 3/4"	MENS O. RR	EXTERIOR	3'-0"	7'-0"	B	FRP		FRP			17/A702	12/A702		C		SET # 106
14	FRP	1 3/4"	WMNS O. RR	EXTERIOR	3'-0"	7'-0"	B	FRP		FRP			17/A702	12/A702		D		SET # 106
15	FRP	1 3/4"	MECH. RM.	EXTERIOR	6'-0"	7'-0"	C	FRP		FRP			17/A702	12/A702		B		SET # 05
16	FRP	1 3/4"	LOBBY	EXTERIOR	6'-0"	7'-0"	F	FRP		FRP			17/A702	12/A702		B		SET # 05
17	HM/ P-LAM	1 3/4"	FURN. STOR.	ASSEMBLY	6'-0"	7'-0"	D	P-LAM		HM			16/A702	11/A702		A	OMIT LIGHTS	SET # 109
18	HM/ P-LAM	1 3/4"	KITCHEN	ASSEMBLY	3'-0"	7'-0"	A	P-LAM		HM			16/A702	11/A702		B		SET # 108
19	FRP	1 3/4"	KITCHEN	EXTERIOR	3'-0"	7'-0"	B	FRP		FRP			17/A702	12/A702				SET # 03
20	HM/ P-LAM	1 3/4"	DRY STORAGE	KITCHEN	3'-0"	7'-0"	A	P-LAM		H.M.			16/A702	11/A702		A		SET # 107
21	FRP	1 3/4"	ASSEMBLY	EXTERIOR	3'-0"	7'-0"	B	FRP		FRP			3/A702	8/A702	13/A702			SET # 04
22	FRP	1 3/4"	ASSEMBLY	EXTERIOR	3'-0"	7'-0"	B	FRP		FRP			3/A702	8/A702	13/A702			SET # 04

ISSUE	DATE	DESCRIPTION
2	03/08/16	ADD REVISIONS

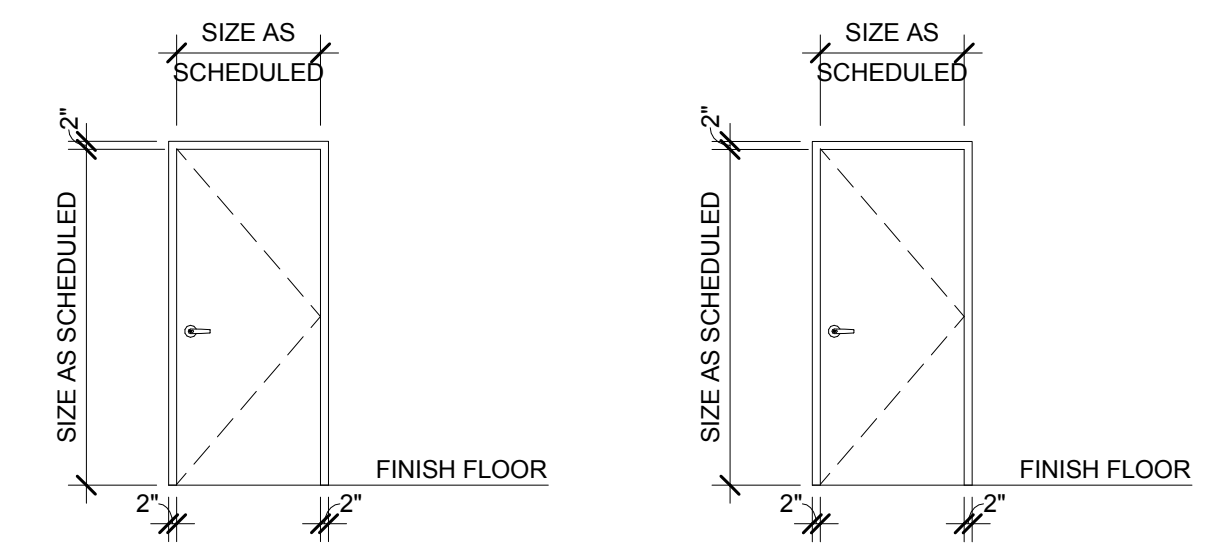
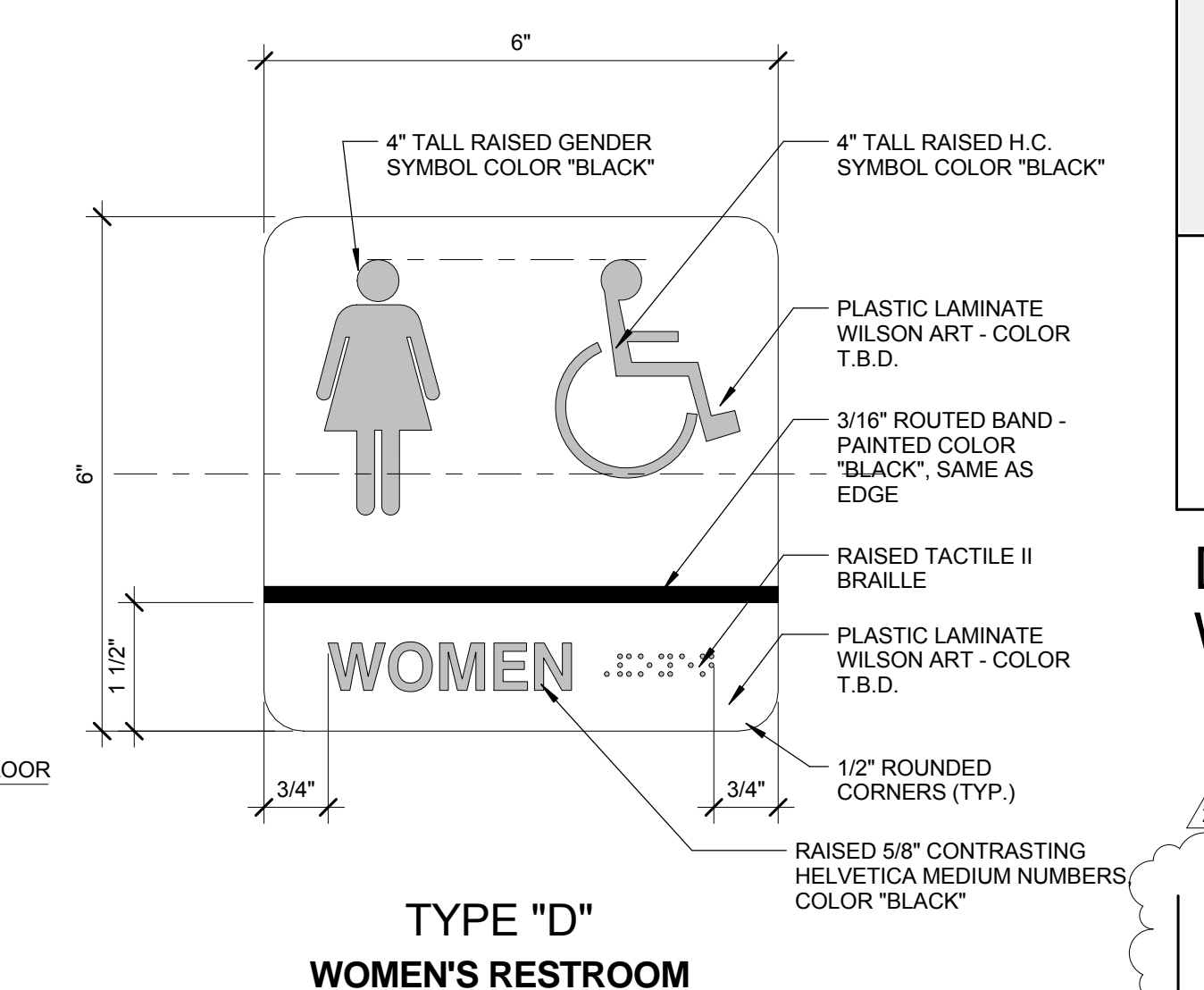
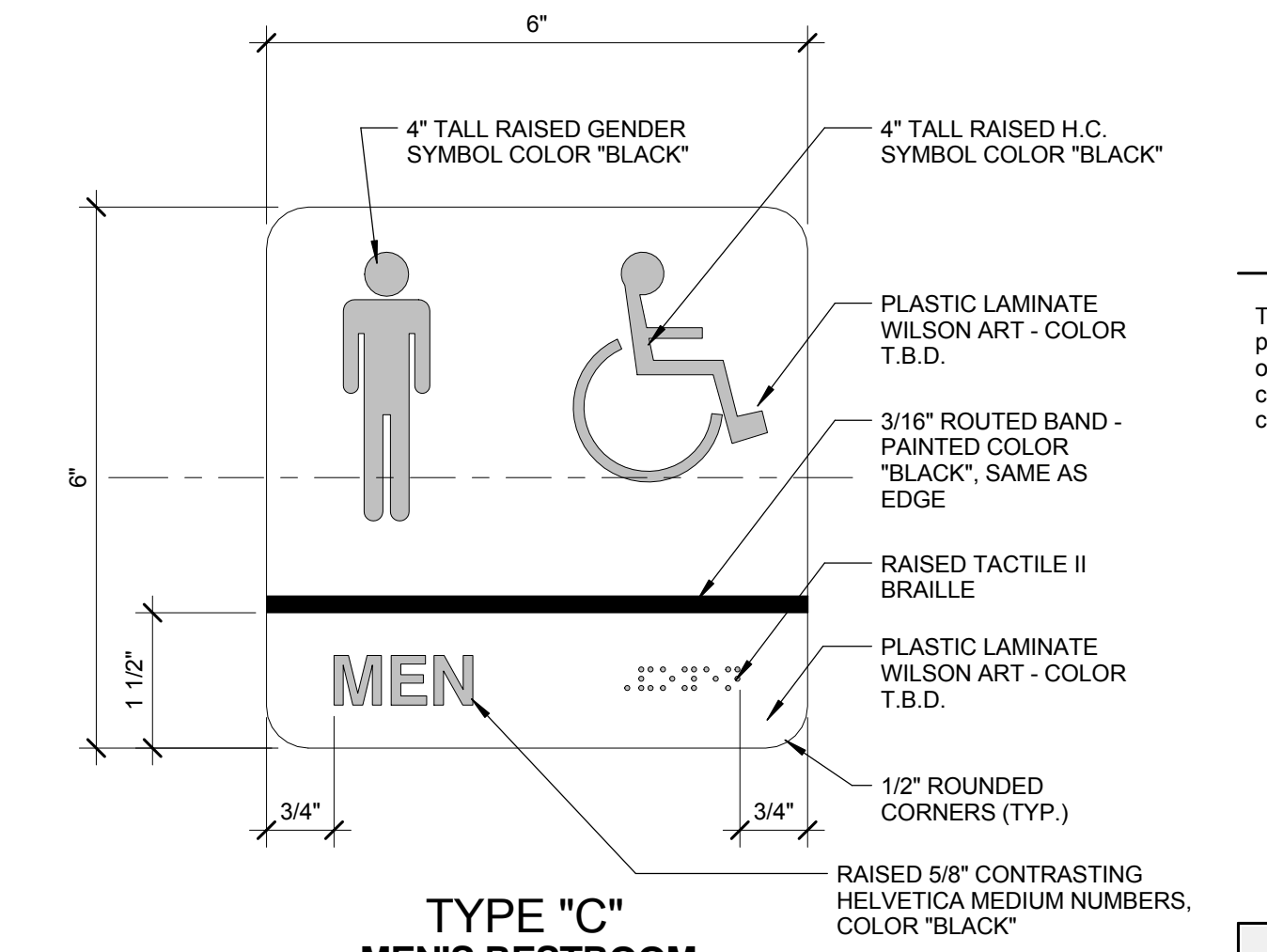
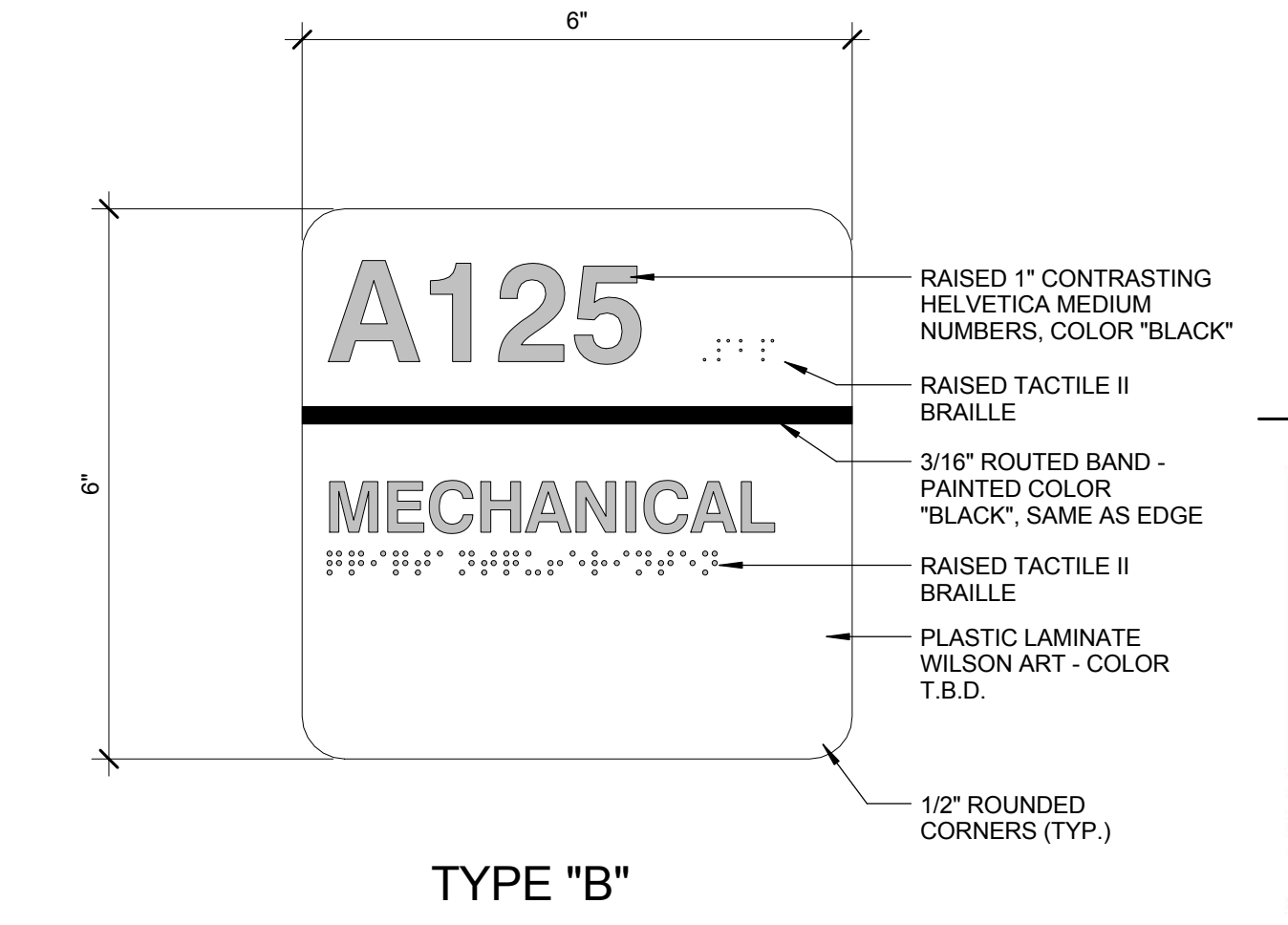
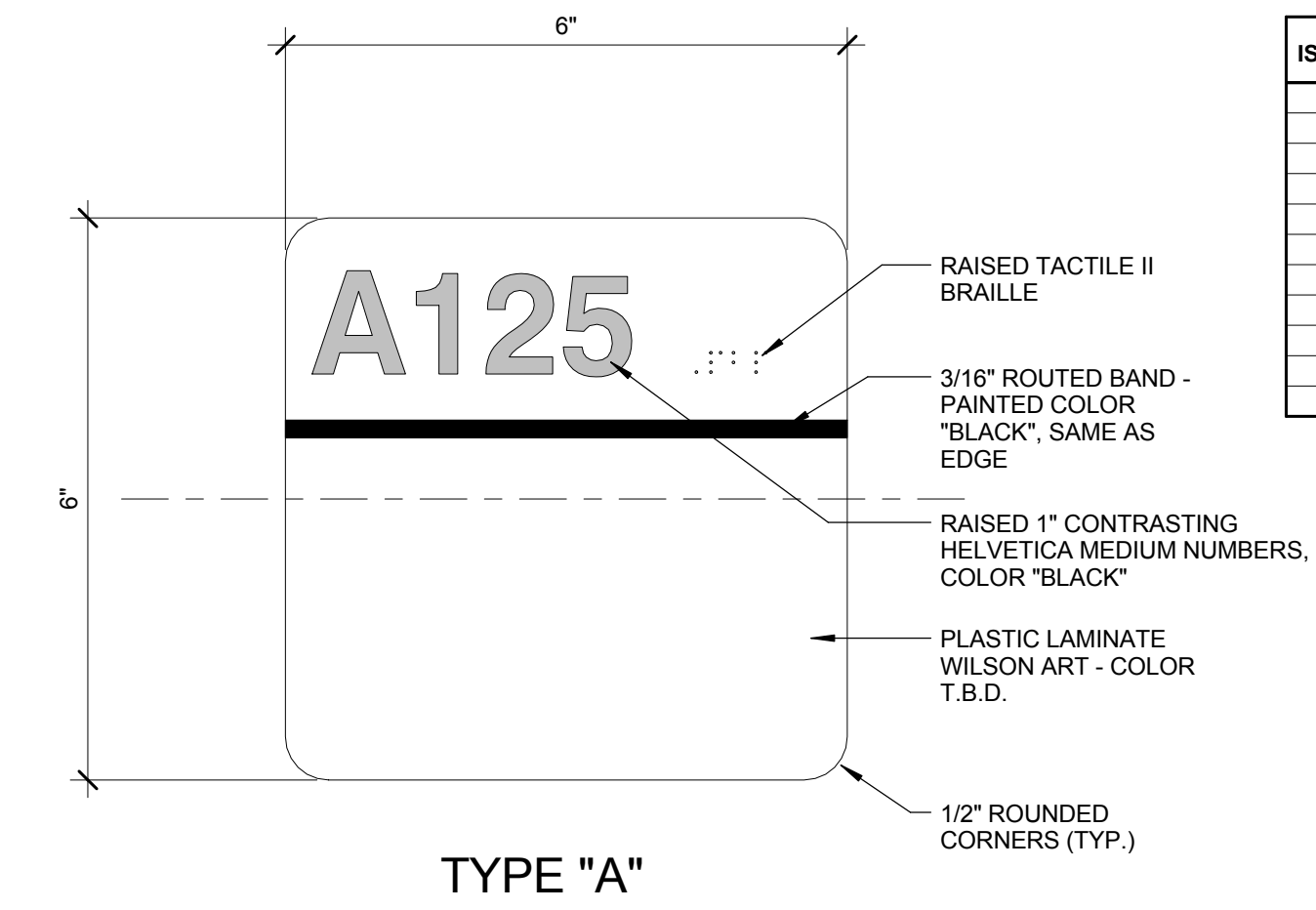

DOOR ELEVATION B
FRP FRAME
FRP DOOR

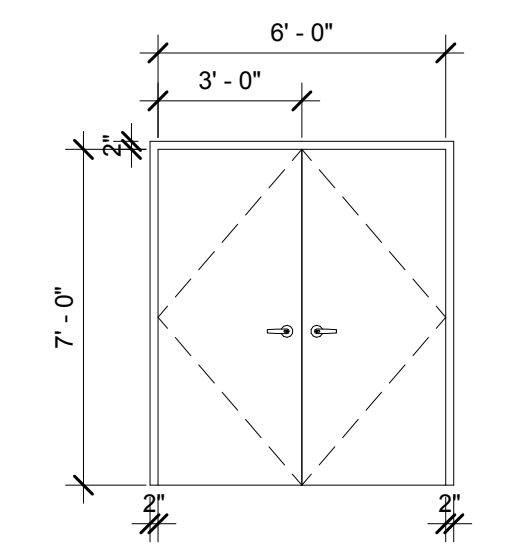

DOOR ELEVATION D
HOLLOW METAL FRAME
PLASTIC LAMINATE DOORS

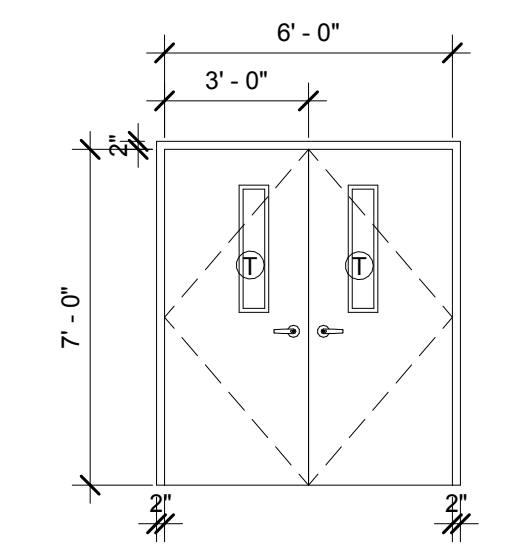

DOOR ELEVATION E
ALUMINUM ANODIZED DOOR WITH 1/4" TEMPERED GLASS

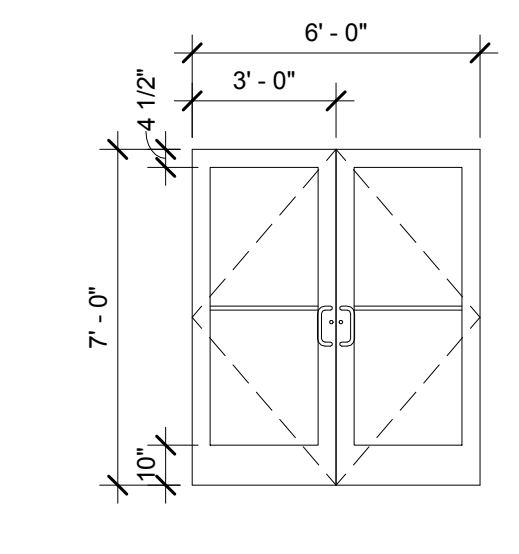

DOOR ELEVATION F
FRP FRAME
FRP DOORS

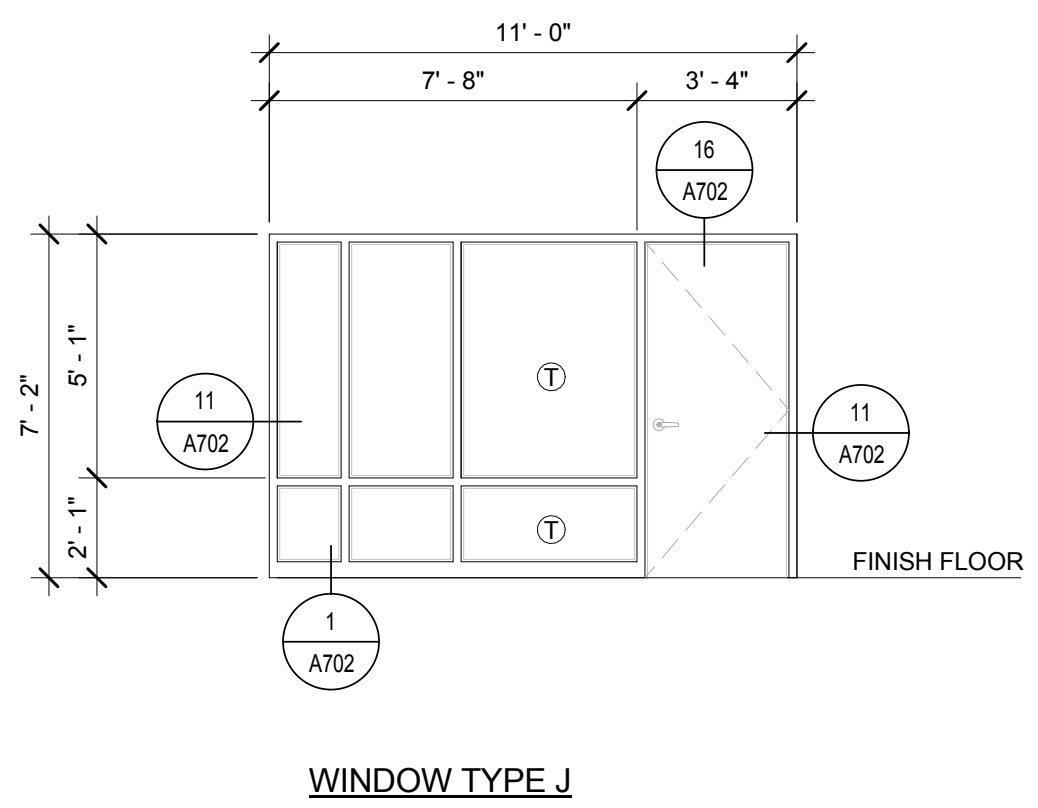
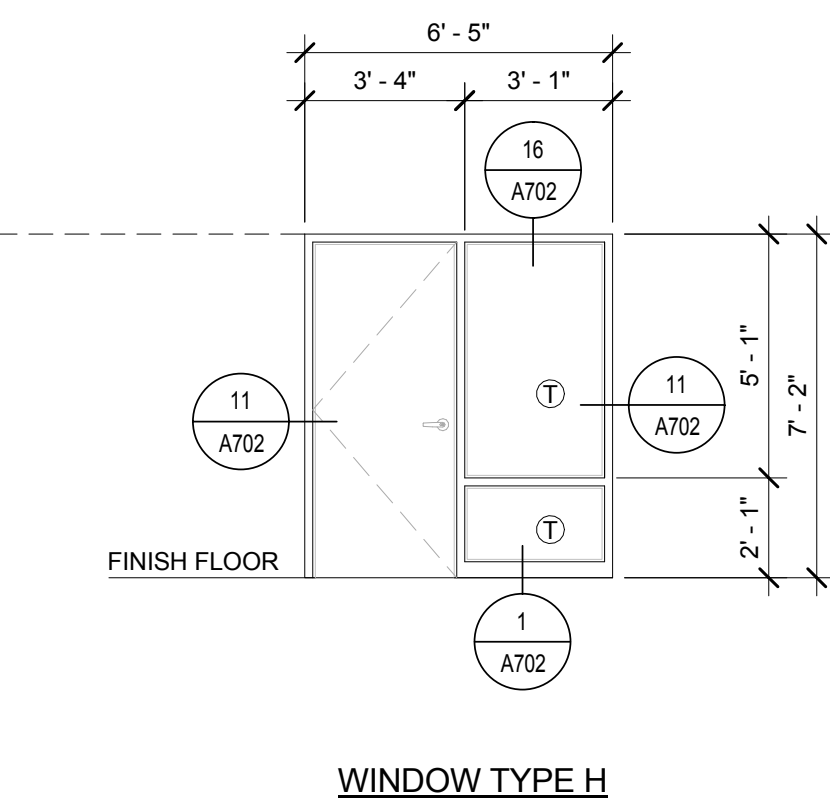
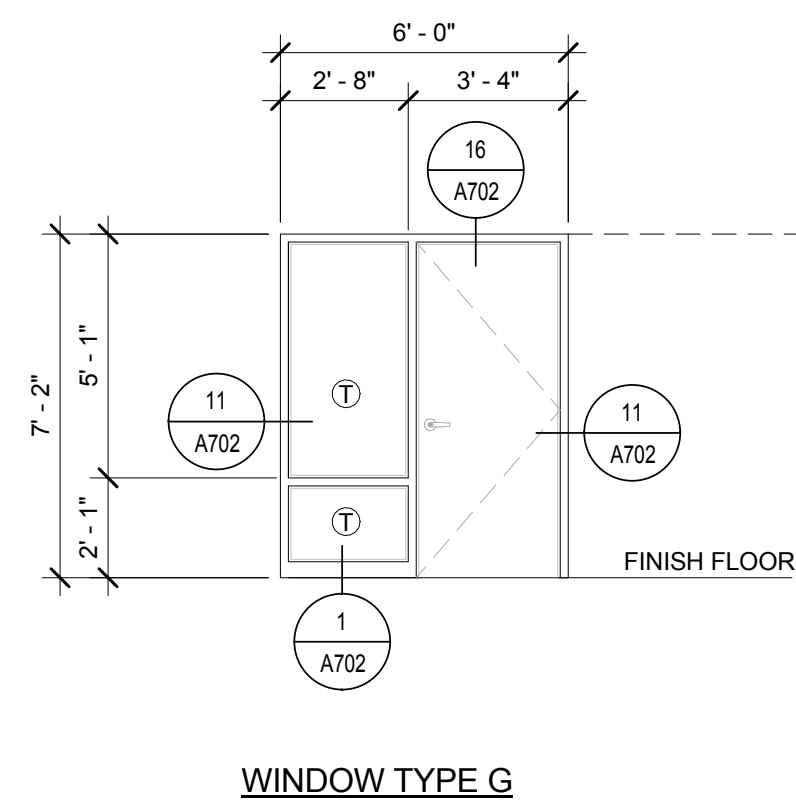
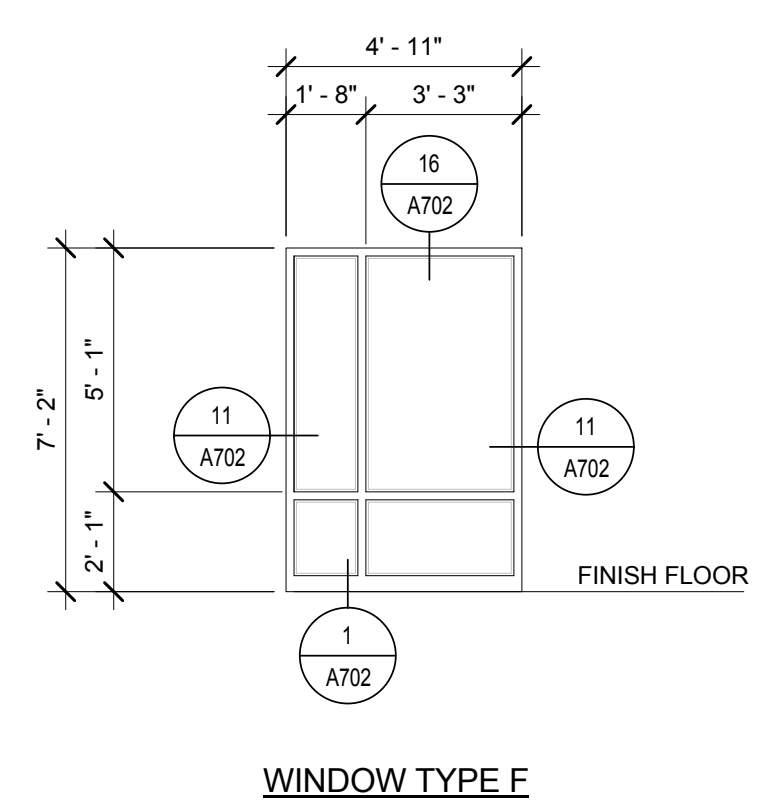
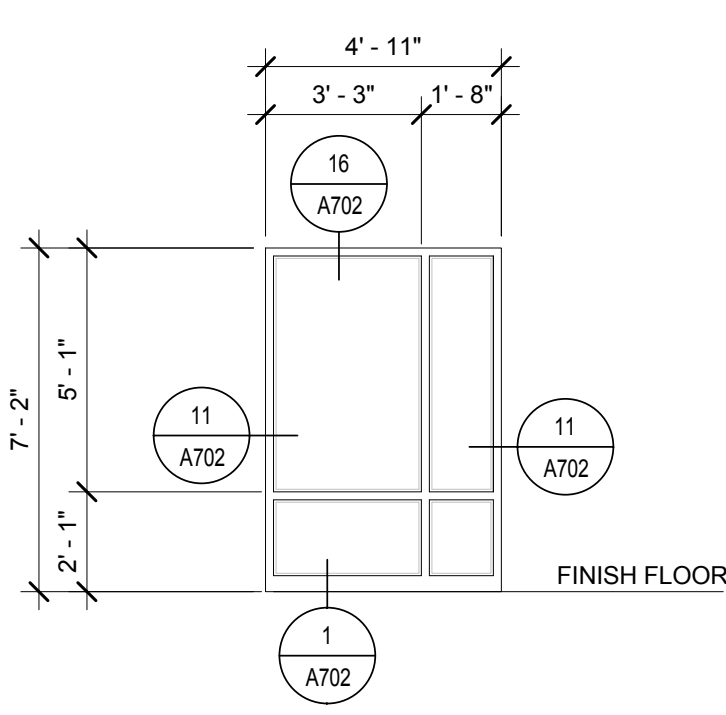
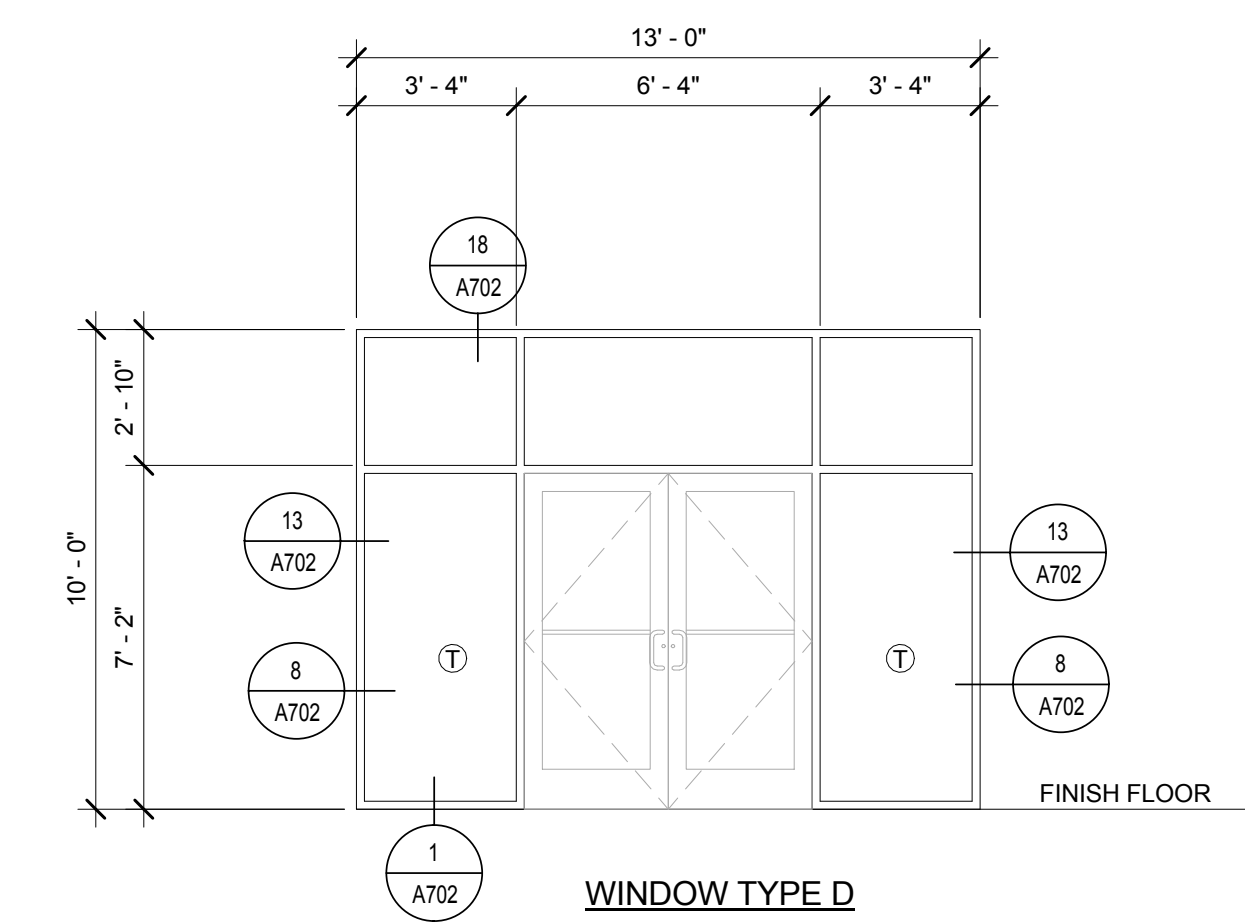
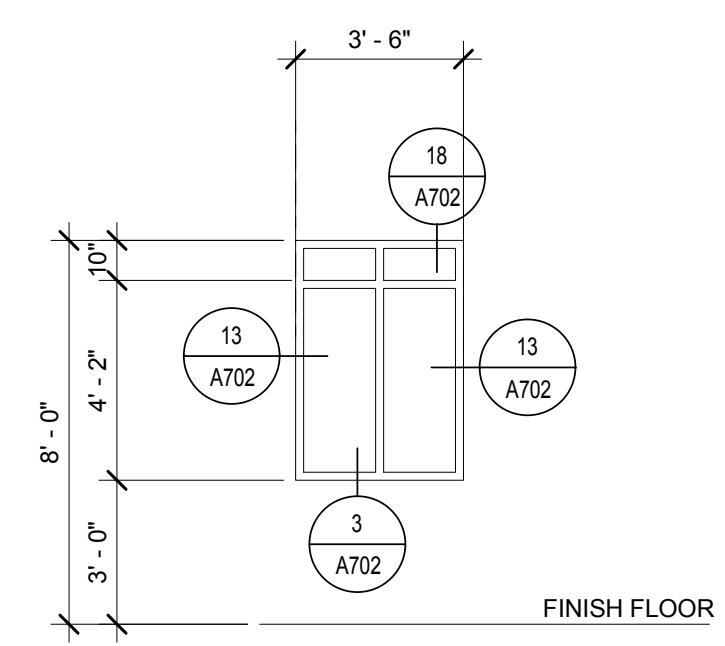
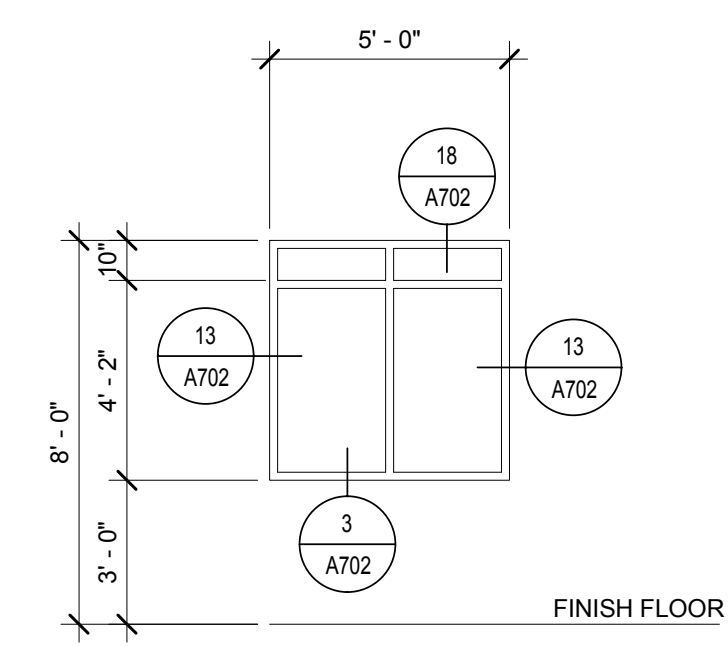
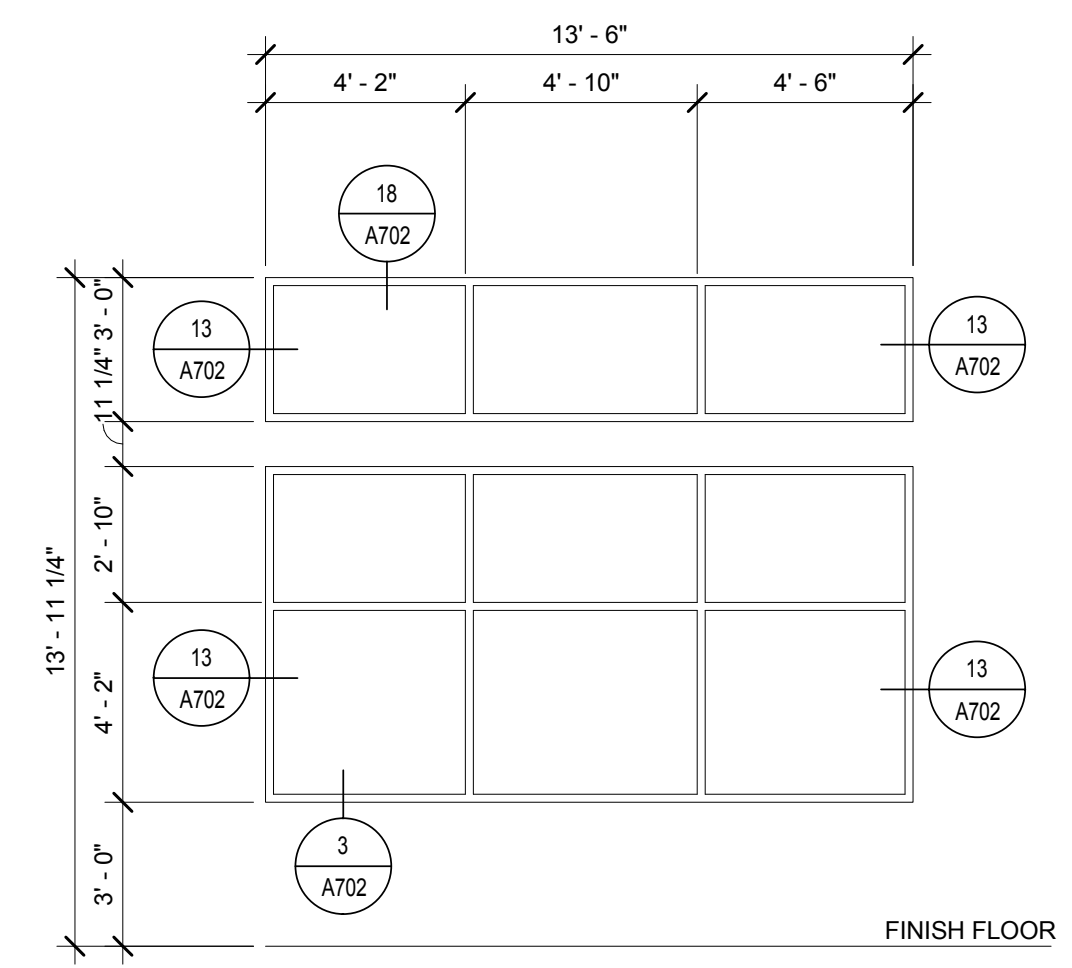

Boucher Design Group LLC
Members A.I.A.
6802 Maple Ridge, Suite 200
Bellaire, Texas 77401
Tel. 713.785.3644
www.bdgap.com

This document is an instrument of service protected by the copyright law of the United States of America, 17 U.S.C § 102, and shall not be copied or reproduced without the express written consent of Boucher Design Group, LLC. 2016

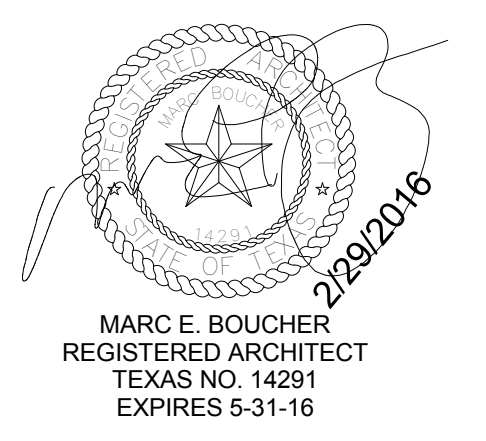

BAYSIDE COMMUNITY CENTER

BACLIFF, TEXAS

GALVESTON COUNTY

DATE	02/29/16
PROJECT NO.	1409000
DRAWN BY	BPA
CHECKED BY	BPA

DOOR AND WINDOW TYPES

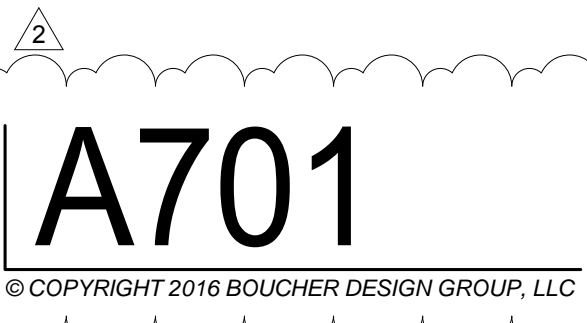

ISSUE	DATE	DESCRIPTION
3	5/16/16	VALUE ENGINEERING

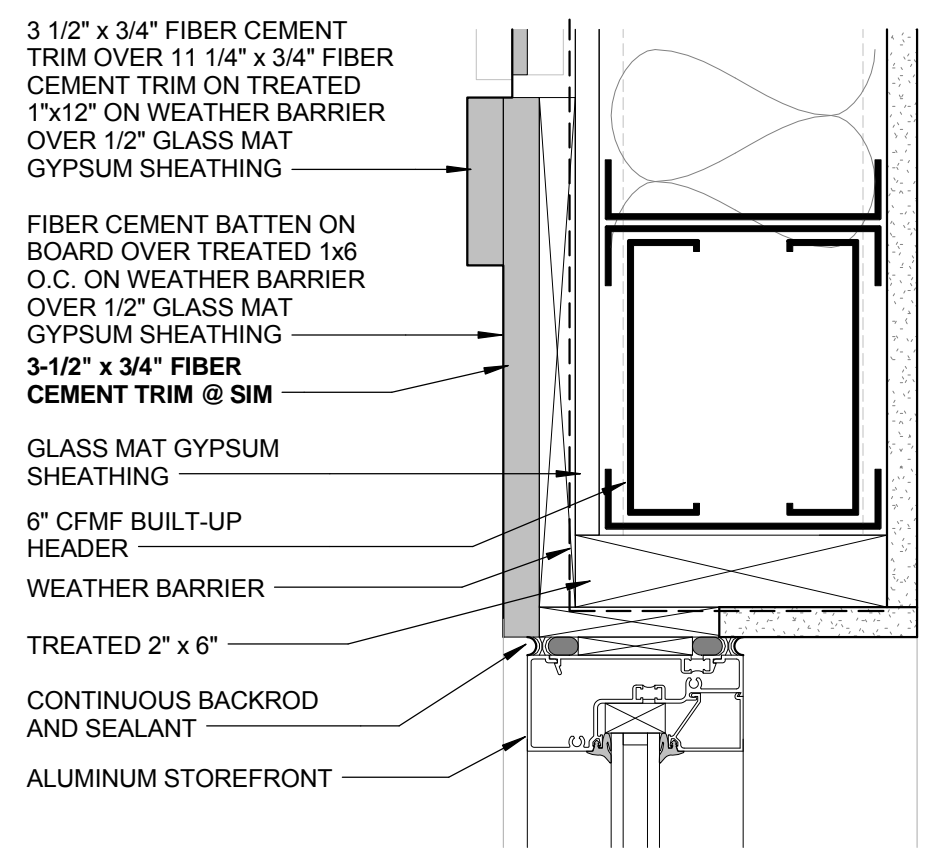

18 | HEAD DETAIL
SCALE: 3" = 1'-0"

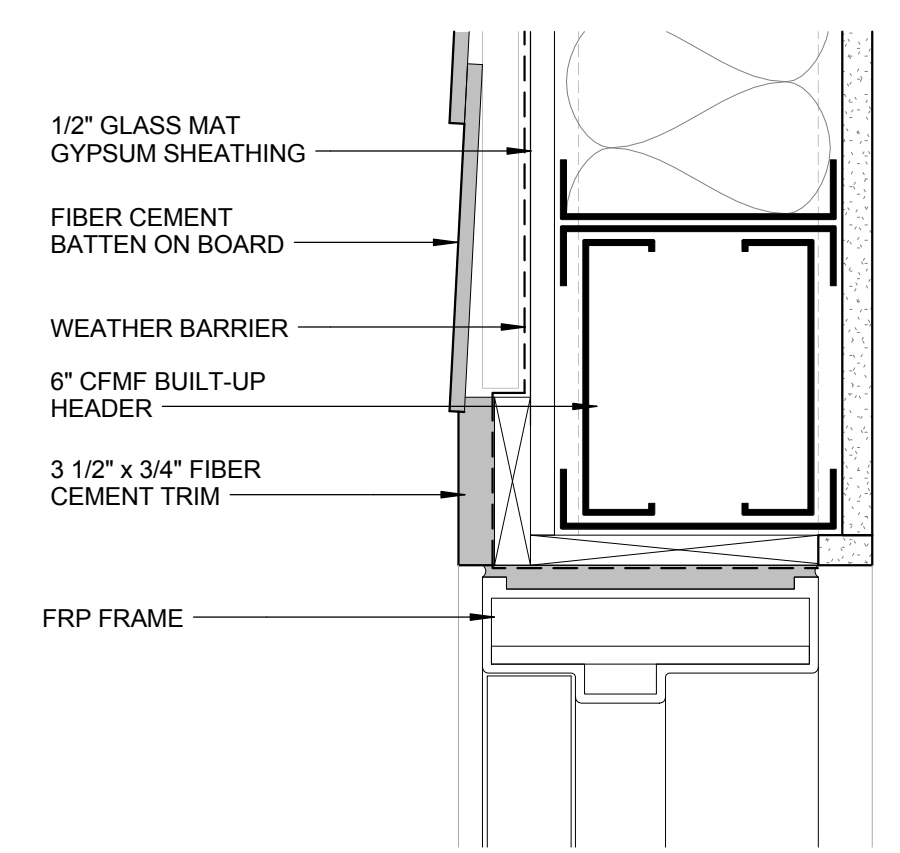

17 | HEAD DETAIL
SCALE: 3" = 1'-0"

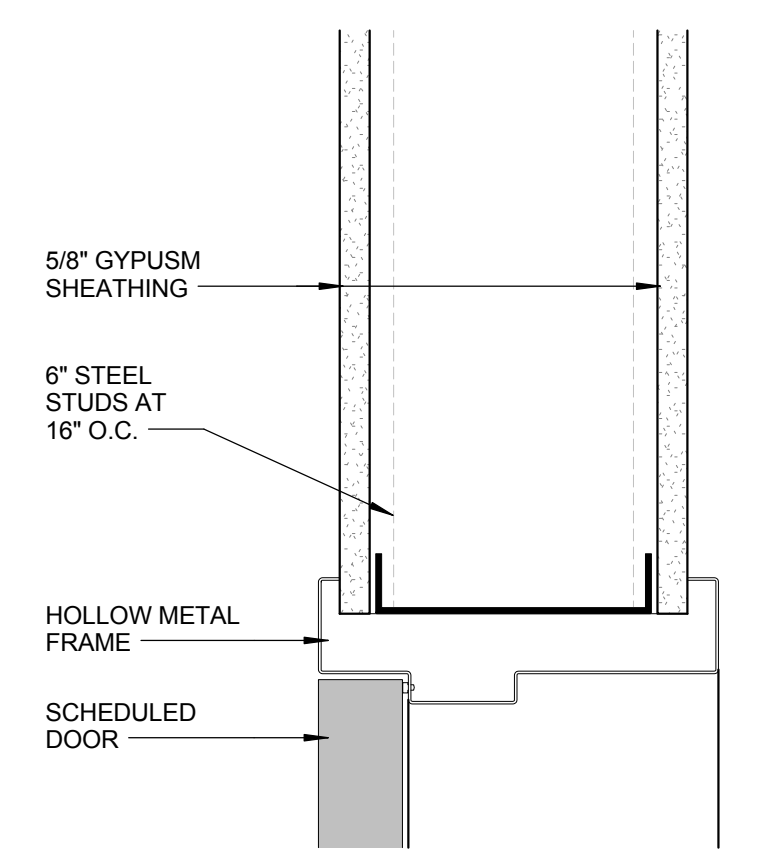

16 | HEAD DETAIL
SCALE: 3" = 1'-0"

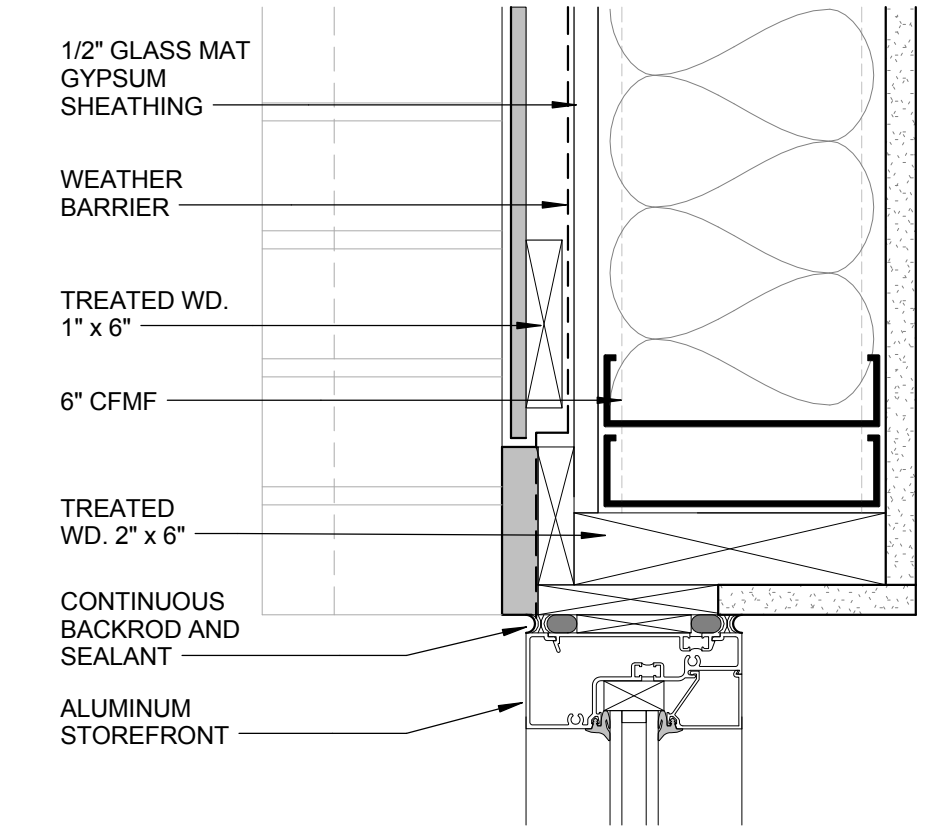

13 | JAMB DETAIL
SCALE: 3" = 1'-0"

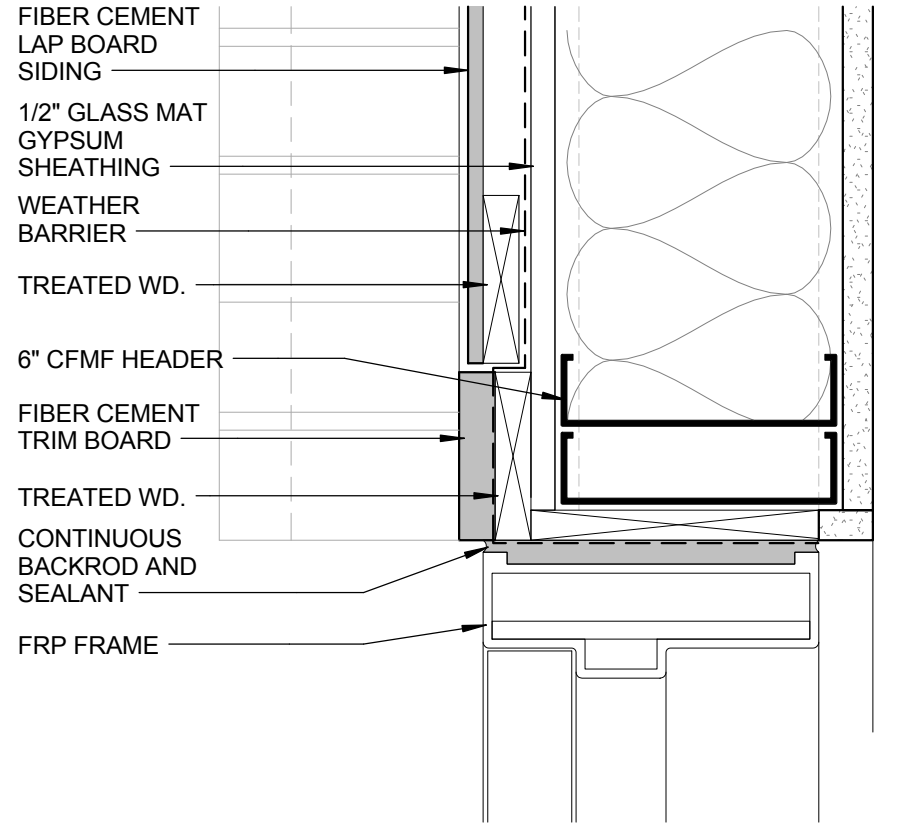

12 | JAMB DETAIL
SCALE: 3" = 1'-0"

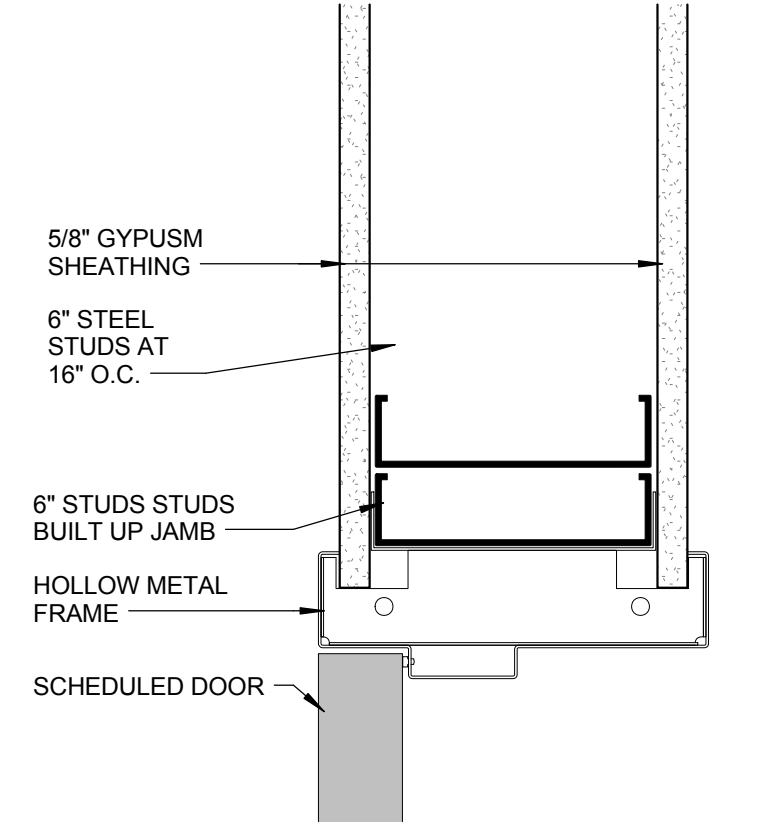

11 | JAMB DETAIL
SCALE: 3" = 1'-0"

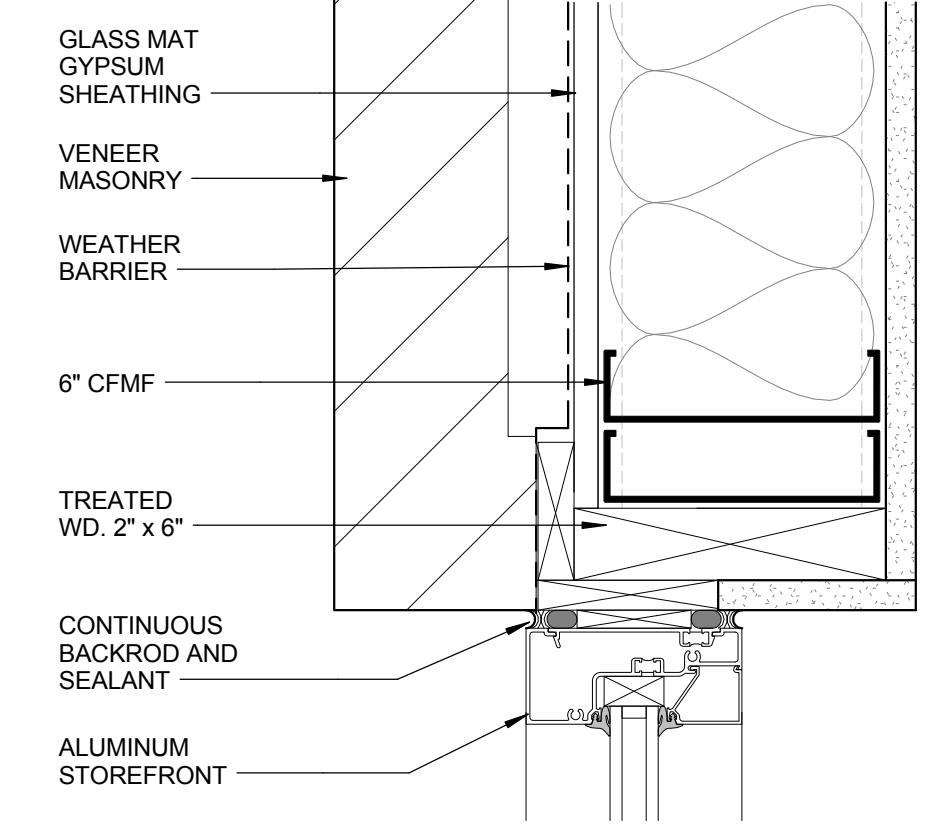

8 | JAMB DETAIL
SCALE: 3" = 1'-0"

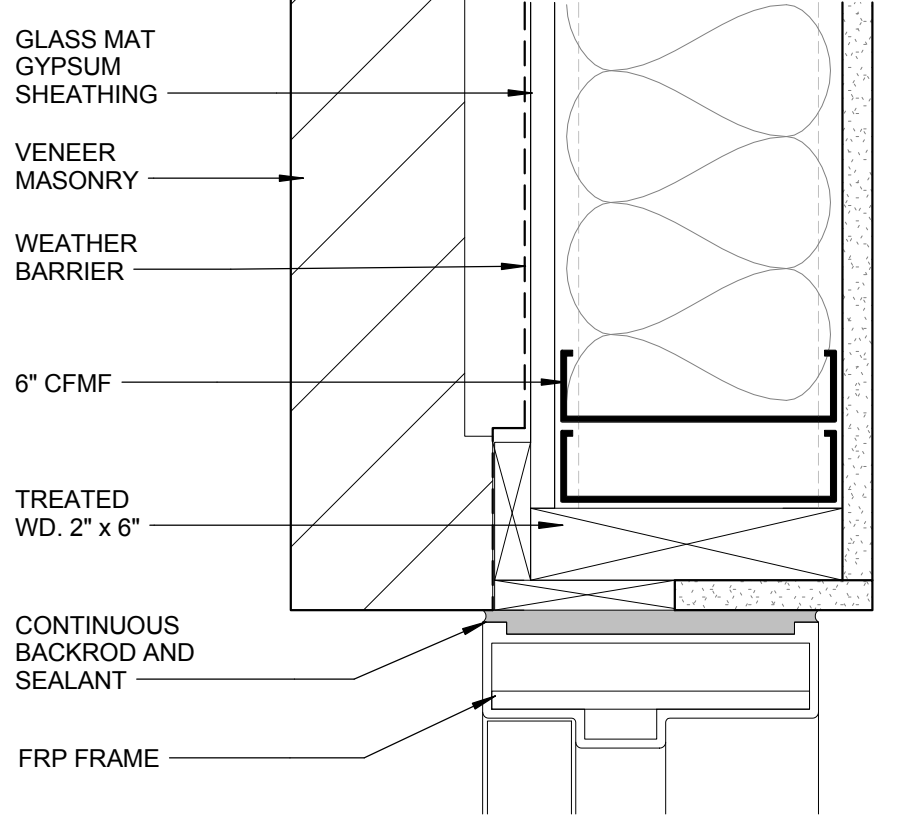

7 | JAMB DETAIL
SCALE: 3" = 1'-0"

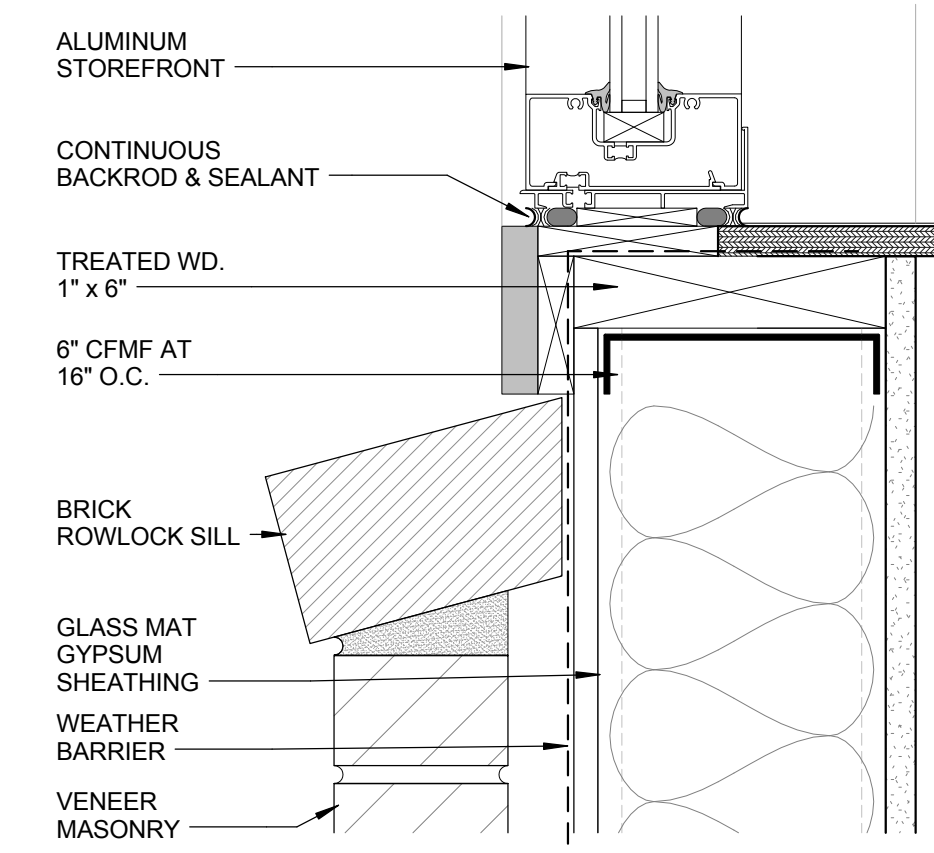

3 | SILL DETAIL
SCALE: 3" = 1'-0"

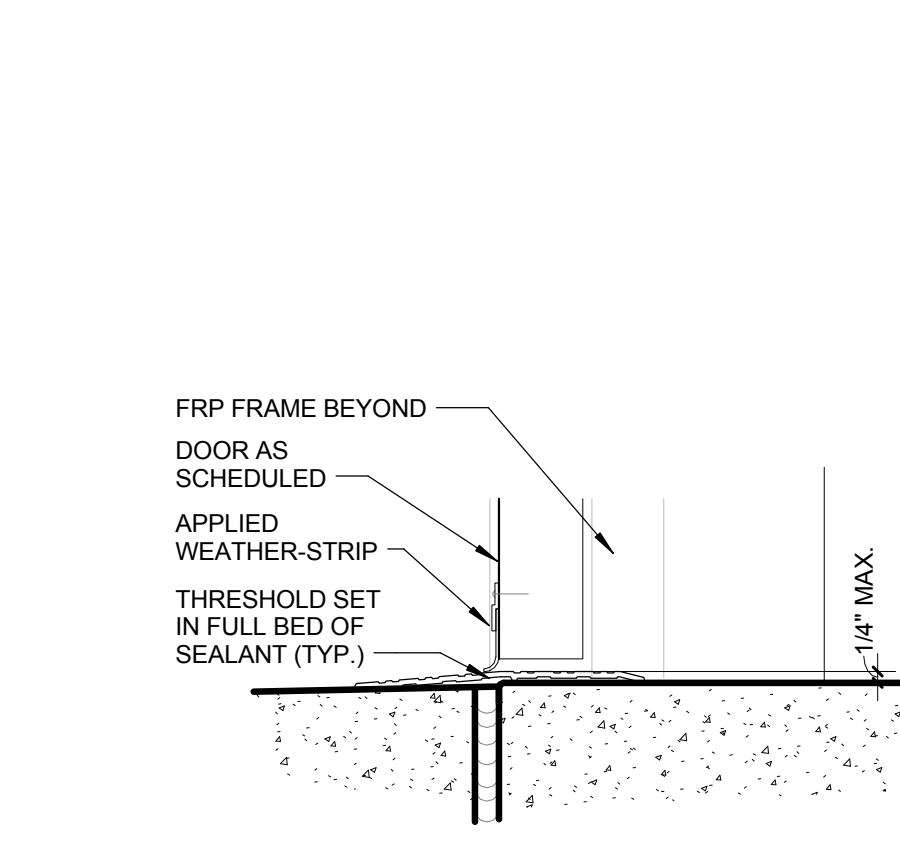

2 | SILL DETAIL
SCALE: 3" = 1'-0"

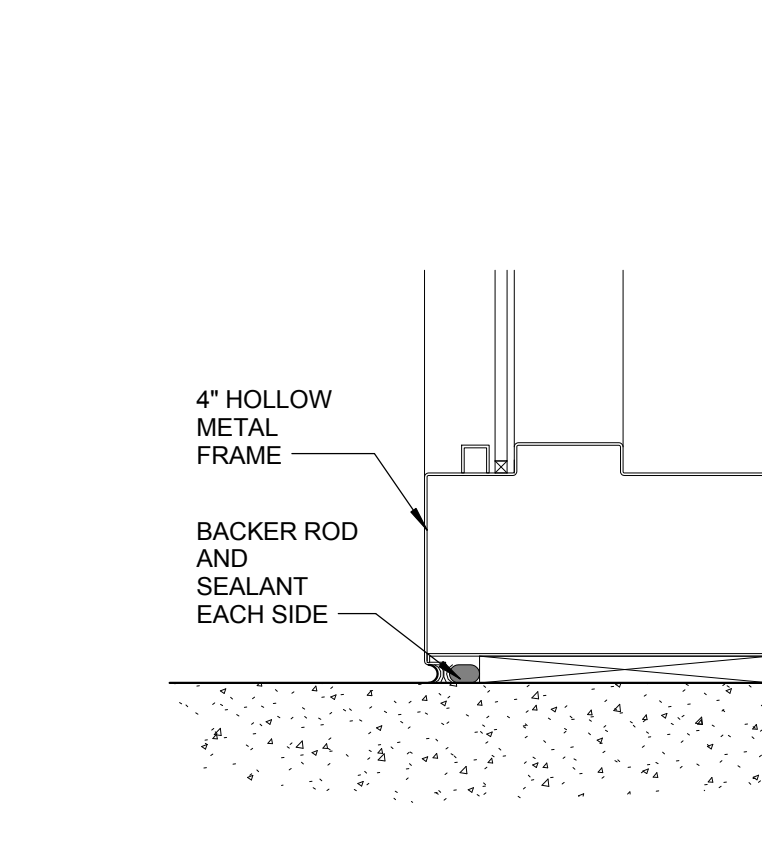

1 | JAMB DETAIL
SCALE: 3" = 1'-0"

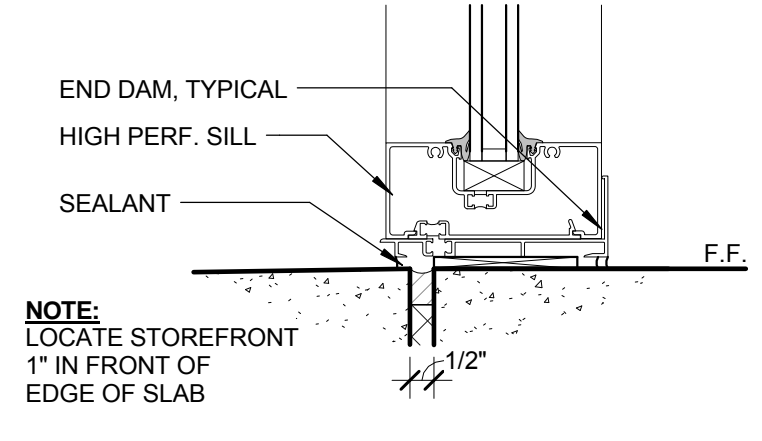

4 | SILL DETAIL
SCALE: 3" = 1'-0"

bdg
architecture
+ planning
boucher design group

Boucher Design Group LLC
Members A.I.A.
6802 Mapleridge, Suite 200
Bellaire, Texas 77401
Tel. 713.785.3644
www.bdgap.com

This document is an instrument of service protected by the copyright law of the United States of America, 17 U.S.C §102, and shall not be copied or reproduced without the express written consent of Boucher Design Group, LLC. 2016

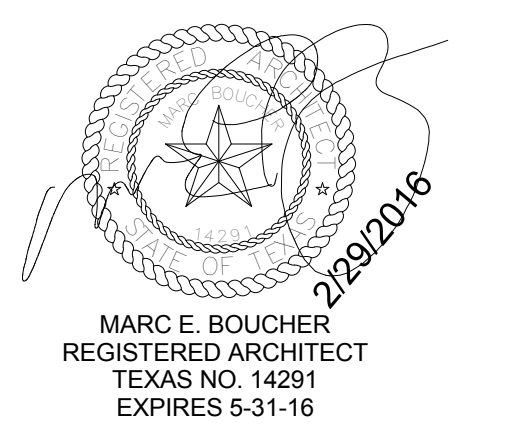

BAYSIDE COMMUNITY CENTER
BACLIFF, TEXAS
GALVESTON COUNTY

DATE	02/17/16
PROJECT NO.	1409000
DRAWN BY	Author
CHECKED BY	Checker

HEAD, JAMB, SILL DETAILS

A702
© COPYRIGHT 2016 BOUCHER DESIGN GROUP, LLC

ISSUE	DATE	DESCRIPTION
2	03/08/16	ADD REFLECTED CEILING

CEILING FINISH LEGEND

[Pattern]	VINYL PANEL CEILING
[Pattern]	ACOUSTIC PANEL CEILING
[Pattern]	GYPSUM CEILING
[Pattern]	BEAD BOARD CEILING

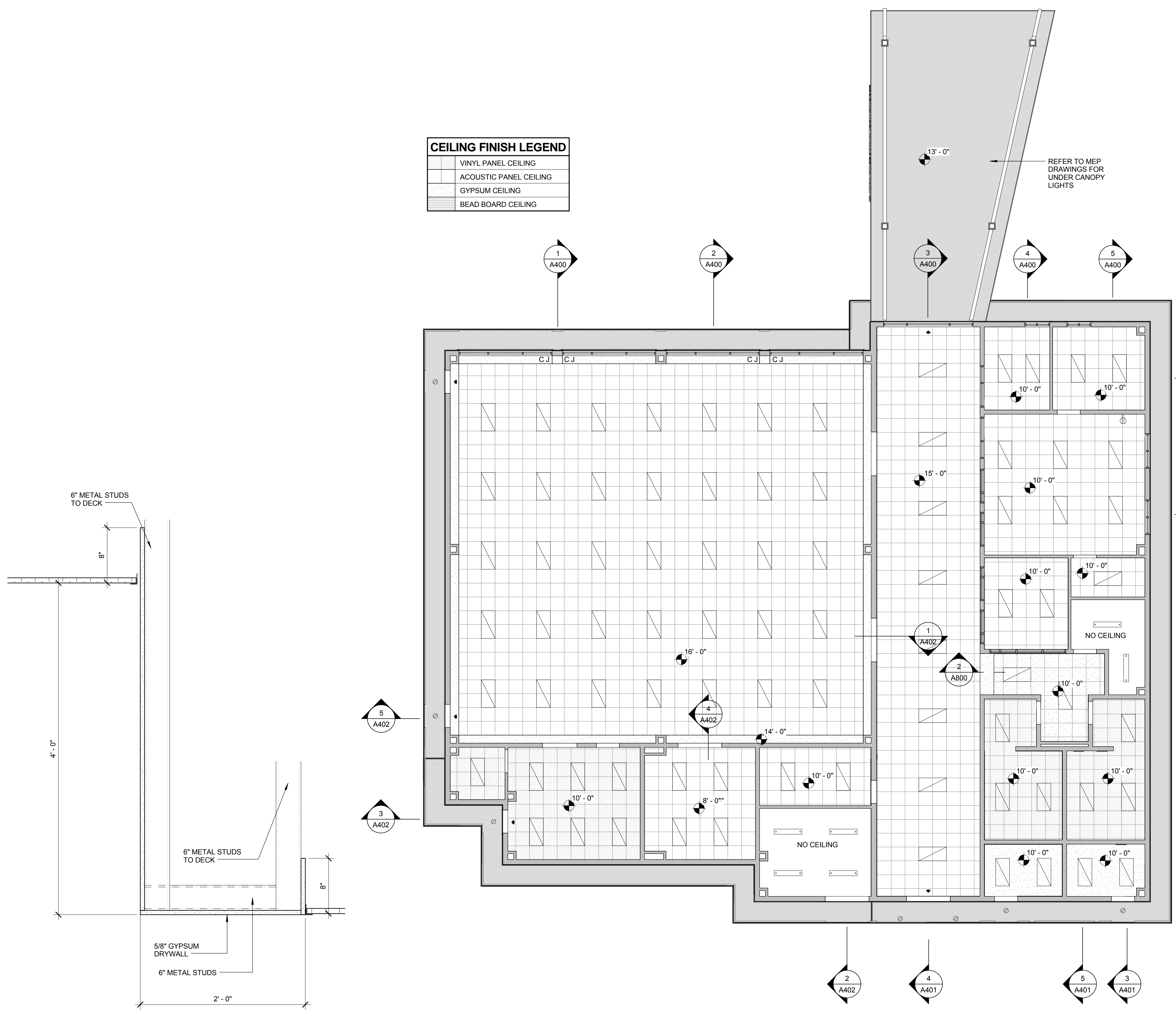

2 | SECTION DETAIL
SCALE: 1 1/2" = 1'-0"

1 | REFLECTED CEILING PLAN
SCALE: 1/8" = 1'-0"

bdg
architecture
+ planning
boucher design group

Boucher Design Group LLC
Members A.I.A.
6802 Mapleridge, Suite 200
Bellaire, Texas 77401
Tel. 713.785.3644
www.bdgap.com

This document is an instrument of service protected by the copyright law of the United States of America, 17 U.S.C §102, and shall not be copied or reproduced without the express written consent of Boucher Design Group, LLC. 2016

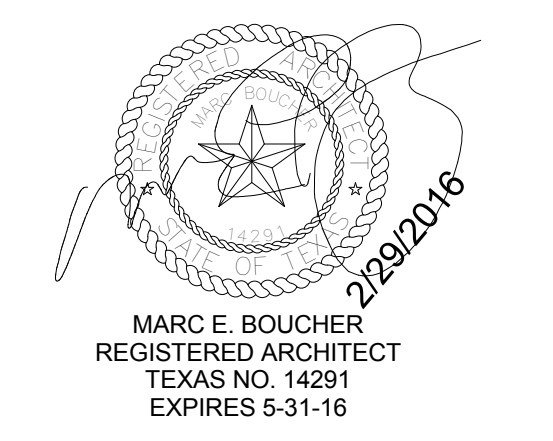

BAYSIDE COMMUNITY CENTER
BACLIFF, TEXAS
GALVESTON COUNTY

DATE	02/29/2016
PROJECT NO.	1409000
DRAWN BY	BW
CHECKED BY	BPA

REFLECTED CEILING PLAN

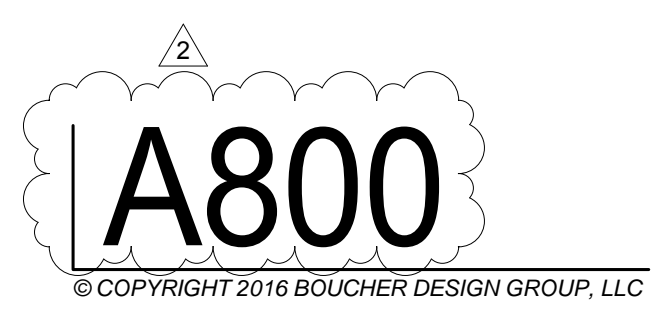

1. STRUCTURAL ABBREVIATIONS

AASHTO	AMERICAN ASSOCIATION OF STATE HIGHWAY AND TRANSPORTATION OFFICIALS	FND	FOUNDATION	PLUMB	PLUMBING
ACI	AMERICAN CONCRETE INSTITUTE	FS	FAR SIDE	PR	PAIR
ADL	ADDITIONAL	FT	FEET, FOOT	PROJ	PROJECTION
ADJ	ADJACENT	FTG	FOOTING	PSI	POUNDS PER SQUARE INCH
AISC	AMERICAN INSTITUTE OF STEEL CONSTRUCTION	FTG	FOOTING	PSF	POUNDS PER SQUARE FOOT
AISI	AMERICAN IRON AND STEEL INSTITUTE	GA	GAUGE	R	RIGHT, RISER, RADIUS
ANSI	AMERICAN NATIONAL STANDARD INSTITUTE	GALV	GALVANIZED	RD	ROOF DRAIN
APPROX.	APPROXIMATE(LY)	GB	GRADE BEAM	RE	REFER
AR	ANCHOR ROD	HORIZ	HORIZONTAL	REF	REFERENCE
ARCH	ARCHITECTURAL	HP	HIGH POINT	REINF	REINFORCE(D), (ING), (MENT)
ASCE	AMERICAN SOCIETY OF CIVIL ENGINEERS	HR	HOUR	REQD	REQUIRED
ASTM	AMERICAN SOCIETY OF TESTING MATERIALS	HS	HOLLOW STRUCTURAL SECTION	REV	REVISION
AWS	AMERICAN WELDING SOCIETY	HSS	HOLLOW STRUCTURAL SECTION	RH	RIGHT HAND
B. BM	BEAM (MILD REINFORCED)	ID	INSIDE DIAMETER	RO	ROUGH OPENING
BC	BOTTOM CHORD	IN	INCHES	S	SOUTH, SLAB
BLDG	BUILDING	IT	JOINT	SCHED	SCHEDULE(D)
BOD	BOTTOM OF DECK	JT	JOINT	SDI	STEEL DECK INSTITUTE
BOT	BOTTOM	K	KIPS, JOIST SERIES	SECT	SECTION
BP	BASE PLATE	KSI	KIPS PER SQUARE INCH	SF	SQUARE FEET
BRG	BEARING	L	SPAN, LEFT	SHT	SHEET
BS	BOTH SIDES	Ld	DEVELOPMENT LENGTH	SIM	SIMILAR
C	CHANNEL COMPRESSION	LG	LENGTH	SJI	STEEL JOIST INSTITUTE
CAMB	CAMBER	LH	LONG, LONGITUDINAL	SL	SLOPE
CIP	CAST-IN-PLACE	LL	LONG LEG	SPA	SPACE
CL	CENTER LINE	LLB	LONG LEG BACK TO BACK	SPC(S)	SPECIFICATION(S)
CLR	CLEAR	LLH	LONG LEG HORIZ.	SQ	SQUARE
COL	COLUMN	LLV	LONG LEG VERTICAL	STD	STANDARD
CONC	CONCRETE	LP	LOW POINT	STIF	STIFFENER
CONT	CONTINUOUS	LW	LONG WAY	STIR	STIRRUP
CPL	CAP PLATE	MATL	MATERIAL	STL	STEEL
CS	CARBON STEEL	MAX	MAXIMUM	STR	STRUCTURAL
CSJ	CONSTRUCTION JOINT	MC	MOMENT CONNECTION, MISC. CHANNEL	T	TOP, TENSION
CTJ	CONTROL JOINT	MFG(S)	MANUFACTURER(S)	T & B	TOP AND BOTTOM
D	DEPTH	MID	MIDDLE	T & G	TONGUE AND GROOVE
DET	DETAIL	MILL	MILL FACE	TEMP	TEMPERATURE
DF	DRILLED FOOTING	MIN	MINIMUM	THK	THICK(NESS)
DIA	DIAMETER	MISC	MISCELLANEOUS	THK	THICK(NESS)
DIAG	DIAGONAL	MO	MASONRY OPENING	TOC	TOP OF CONCRETE
DIM	DIMENSION	MS	MILD STEEL	TOF	TOP OF FOOTING
DL	DEAD LOAD	MT	STRUCTURAL TEE CUT FROM MISC. STEEL	TOL	TOP OF LEDGE
DN	DOWN	N	NORTH	TOP	TOP OF PANEL
DO	DITTO	NS	NEAR SIDE	TOS	TOP OF STEEL
DWG	DRAWING	NTS	NOT TO SCALE	TOT	TOTAL
DWL	DOWEL	NO	NUMBER	TOW	TOP OF WALL
E	EAST	NOM	NOMINAL	TRD(S)	TREAD(S)
EA	EACH	NS	NEAR SIDE	TOJ	TOP OF JOIST
EF	EACH FACE	NTS	NOT TO SCALE	TYP	TYPICAL
EJ	EXPANSION JOINT	OC	ON CENTER	UL	UNDERWRITERS LABORATORY
EL	ELEVATION	OD	OUTSIDE DIAMETER	UNIF	UNIFORM
ELEC	ELECTRICAL	OPNG	OPENING	UON	UNLESS OTHERWISE NOTED
ELEV	ELEVATOR	OPP	OPPOSITE	V	BEAM END SHEAR
EQ	EQUAL(LY)	PL	PLATE	VB	VERTICAL BRACE
EW	EACH WAY	PLF	POUNDS PER LINEAR FOOT	VERT	VERTICAL
EXIST	EXISTING	W	WALL, WEST, WIDTH, WIDE FLANGE	W	WALL, WEST, WIDTH, WIDE FLANGE
EXP	EXPANSION	W/	WITH	WL	WIND LOAD, WATER LEVEL, WORKING LINE
FD	FLOOR DRAIN	WP	WATERPROOF, WORKING POINT	W/	WITH
F.F.E.	FINISH FLOOR ELEVATION	P	PLATE	W/	WITH
		RE:	REFER TO	W/	WITH

2. STRUCTURAL LEGEND

SYMBOL	ITEM
	PRECAST CONCRETE PANEL
	SPREAD FOOTING MARK
	PLINTH MARK
	COLUMN MARK
	CONTINUOUS WALL FOOTING MARK
	BASEMENT WALL MARK
	RETAINING WALL MARK
	BASE PLATE MARK
	STRUCTURAL STEEL COLUMN SPLICE TYPE
	STRAIGHT SHAFT DRILLED PIER FOOTING
	MILD REINFORCED CONCRETE BEAM MARKS
	MILD REINFORCED CONCRETE JOIST MARK
	SPAN DIRECTION OF A MILD REINFORCED CONCRETE SLAB WITH MAIN REINFORCING MARK S1
	SPAN DIRECTION OF 5 1/2" THICK CONCRETE SLAB W/ TYPE 1 STEEL DECK
	SPAN DIRECTION OF A BARE STEEL DECK TYPE 2 NOT HAVING ANY CONCRETE TOPPING
	STANDARD SJI OPEN WEB STEEL JOIST, K SERIES WITH 5 KIPS END SHEAR
	STANDARD AISC ROLLED SHAPE OF W27x84 AT ELEVATION 24'-0"
	STANDARD AISC ROLLED SHAPE OF W21x55 WITH 1" UPWARD CAMBER
	STANDARD AISC ROLLED SHAPE OF W18x35 WITH 20 KIPS BEAM END SHEAR
	STANDARD AISC ROLLED SHAPE OF W14x22 WITH 10 HEADED SHEAR CONNECTORS EQUALLY SPACED
	STANDARD AISC ROLLED SHAPE OF W21x50 WITH 28 HEADED SHEAR CONNECTORS EQUALLY SPACED FROM LEFT TO RIGHT AS 10 CONNECTORS / 6 CONNECTORS / 12 CONNECTORS
	STANDARD 'K' SERIES JOIST
	KNEE BRACE
	STEEL ANGLE
	STEEL ANGLE BACK TO BACK
	STANDARD ROLLED SHAPE
	STANDARD ROLLED CHANNEL
	STANDARD STEEL PIPE
	HOLLOW STRUCTURAL SECTION
	AT
	AND
	BY
	CENTER LINE
	ON CENTER
	DIAMETER
	PERCENT
	PLATE
	REFER TO

2. STRUCTURAL LEGEND CONT.

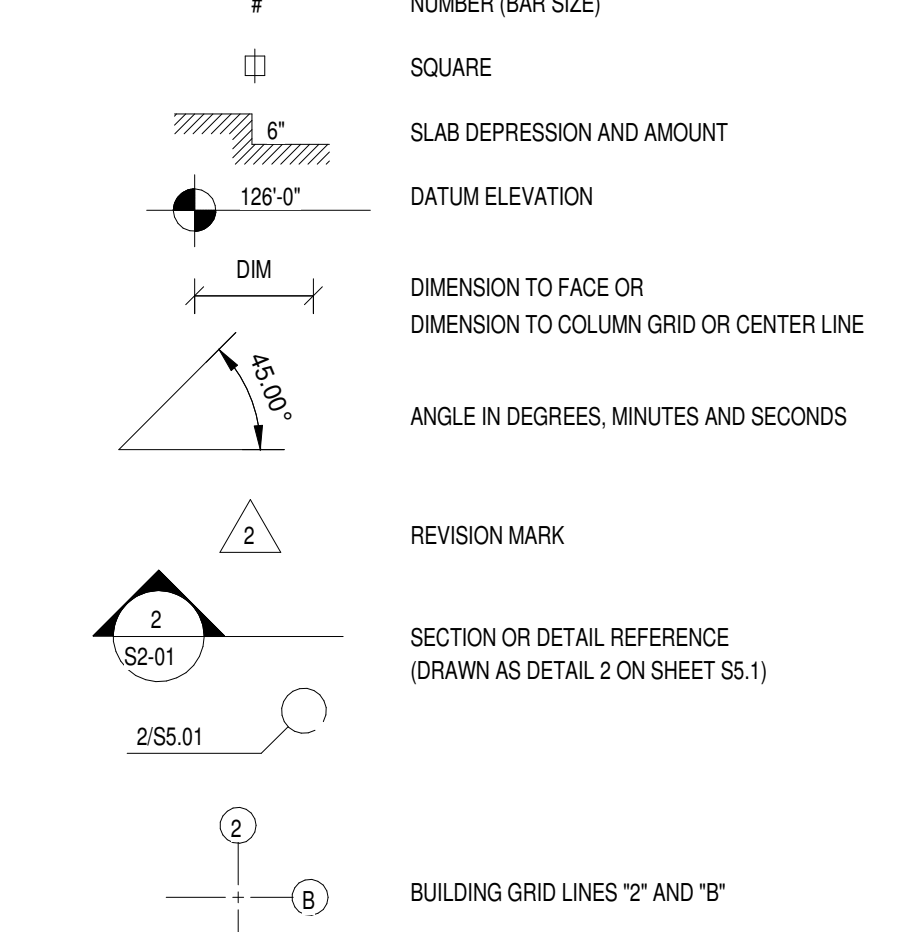

3. STRUCTURAL CONCEPT, STANDARDS AND LOADS

A. DESIGN CONCEPT:

THE STRUCTURE AS SHOWN HAS BEEN DESIGNED IN ACCORDANCE WITH THE BUILDING CODE REQUIREMENTS AND DESIGN STANDARDS TO SUPPORT THE FINAL BUILDING SERVICE LOADS. THE CONTRACTOR SHALL BE RESPONSIBLE FOR PROVIDING ADDITIONAL SUPPORTS FOR THE STRUCTURE IF NECESSITATED BY THE CONSTRUCTION SEQUENCE OR METHODS OF FABRICATION, HANDLING, ERECTION, AND OTHER CONSTRUCTION OPERATIONS.

B. BUILDING CODES AND DESIGN STANDARDS:

- INTERNATIONAL BUILDING CODE, 2006 EDITION.
- AMERICAN SOCIETY OF CIVIL ENGINEERS (ASCE); MINIMUM DESIGN LOADS FOR BUILDINGS AND OTHER STRUCTURES, ASCE 7, AS AMENDED.
- AMERICAN CONCRETE INSTITUTE (ACI); BUILDING CODE REQUIREMENTS FOR REINFORCED CONCRETE, ACI 318, AS AMENDED.
- AMERICAN INSTITUTE OF STEEL CONSTRUCTION (AISC); MANUAL OF STEEL CONSTRUCTION, 9TH EDITION (ASD), 1989, AS AMENDED.
- AMERICAN WELDING SOCIETY (AWS).
- STEEL JOIST INSTITUTE (SJI); STANDARD SPECIFICATIONS FOR OPEN WEB STEEL JOISTS AND JOIST GIRDERS.
- STEEL DECK INSTITUTE (SDI); DESIGN MANUAL FOR COMPOSITE DECKS, FORM DECKS, ROOF DECKS, AND CELLULAR METAL FLOOR DECK WITH ELECTRICAL DISTRIBUTION.

C. GRAVITY LOADS:

SUPERIMPOSED LOADS ARE GIVEN IN POUNDS PER SQUARE FOOT (PSF).

BUILDING AREA	DEAD LOAD (PSF)	LIVE LOAD (PSF)
1. SLAB ON GRADE	0	100
2. ROOF	20	20

*INCLUDES AN ALLOWANCE OF 15 PSF FOR PARTITION OR IF WEIGHT OF EQUIPMENT IS MORE.

D. LATERAL DESIGN LOADS:

- WIND LOADS FOR A BASIC WIND SPEED OF 140 MPH 3-SECOND GUST, WITH EXPOSURE C AND AN IMPORTANCE FACTOR OF 1.15.
- COMPONENT AND CLADDING PRESSURES ARE AS FOLLOWS:

TYPE	TRIBUTARY AREA	PRESSURES (PSF)		
		CORNER	PERIMETER	FIELD
WALLS	10 FT ²	-70, +53	-	-57, +53
ROOF	10 FT ²	-145	-97	-58
PARAPET	10 FT ²	-106, +180	-	-93, +132

- RE: IBC 2006 FOR DESCRIPTION OF CORNER, PERIMETER & FIELD.
- POSITIVE PRESSURES ARE PRESSURES ACTING TOWARD THE BUILDING.
- NEGATIVE PRESSURES ARE PRESSURES ACTING AWAY FROM THE BUILDING.

E. GROUND SNOW LOADS: 5 PSF

F. SPECIAL LOADS:

STAIR TREADS, RAILING AND GUARDRAILS

ITEM	REQUIRED CAPACITY
TREADS	300 POUNDS AT CENTER
TOP RAILS	50 PLF HORIZONTALLY
OTHER RAILS, FILLERS & CONNECTIONS	50 PSF HORIZONTALLY
HAND RAILS	200 POUNDS ANY DIRECTION

4. GENERAL NOTES FOR CONSTRUCTION

- CONSTRUCTION METHODS, PROCEDURES AND SEQUENCES ARE THE RESPONSIBILITY OF THE CONTRACTOR AND THE CONTRACTOR SHALL TAKE ALL THE NECESSARY MEASURES TO MAINTAIN AND PROTECT THE STRUCTURAL INTEGRITY OF ALL CONSTRUCTION AT ALL STAGES.
- ALL PROPOSED SUBSTITUTIONS MUST BE EQUAL OR BETTER AND SHALL BE REVIEWED BY THE ARCHITECT/ENGINEER PRIOR TO ANY PERTINENT WORK AND PRIOR TO THE AWARD OF THE CONTRACT.
- NOT ALL OPENINGS AND OTHER COMPONENTS THAT ARE REQUIRED HAVE BEEN SHOWN IN THE STRUCTURAL DRAWINGS. COORDINATE WITH THE ARCHITECTURAL, MECHANICAL, PLUMBING AND ELECTRICAL DRAWINGS AND VERIFY THE LOCATIONS AND SIZES OF ALL CHASES, INSERTS, OPENINGS, SLEEVES, FINISHES, DEPRESSIONS, PADS AND OTHER PROJECT REQUIREMENTS. FLOOR PLAN WILL BE FURNISHED FOR THAT PURPOSE.
- THE CONTRACTOR IS RESPONSIBLE FOR REVIEWING THE MECHANICAL, ELECTRICAL, PLUMBING AND ARCHITECTURAL DRAWINGS TO DETERMINE WHERE OPENINGS ARE REQUIRED IN REINFORCED CONCRETE BEAMS, SLABS AND WALLS.
- THE CONTRACTOR SHALL SUBMIT SHOP DRAWINGS, DETAILING ALL THE OPENINGS, INCLUDING ADDED REINFORCEMENT AS SHOWN ON THE TYPICAL WALL, SLAB AND BEAM OPENING DETAILS FOR REVIEW.
- ADDITIONAL REINFORCEMENT ABOVE THAT SHOWN IN THE TYPICAL SLAB AND BEAM OPENING DETAILS MAY BE REQUIRED AND WILL BE REVIEWED ON THE SHOP DRAWINGS.
- USE THE MANUFACTURER'S CERTIFIED DRAWINGS AND SPECIFICATIONS FOR THE EQUIPMENT ANCHORAGE AND DETAILS.
- ALL CONSTRUCTION JOINTS SHOWN ON THE STRUCTURAL DRAWINGS SHALL BE INCORPORATED INTO THE STRUCTURE. ADDITIONAL CONSTRUCTION JOINTS TO FACILITATE CONSTRUCTION SHALL BE LOCATED AND DETAILED ON THE SHOP DRAWINGS FOR REVIEW.
- HORIZONTAL CONSTRUCTION JOINTS SHALL NOT BE PERMITTED IN BEAMS UNLESS SHOWN ON THE STRUCTURAL DRAWINGS.
- ALL CONSTRUCTION AND CONTROL JOINTS FOR BEAMS WHICH ARE EXPOSED TO VIEW ARE TO BE LOCATED TO COINCIDE WITH THE ARCHITECTURAL RUSTICATION JOINTS AS SHOWN ON THE BUILDING ELEVATION SHEETS OR AS REVIEWED IN WRITING.
- SHOP DRAWINGS:

- THE TERM "SHOP DRAWINGS" INCLUDES FABRICATION, MANUFACTURING, ERECTION AND SETTING DRAWINGS, BROCHURES, CERTIFICATES, AND PRODUCT DATA DESCRIBING MATERIALS AND EQUIPMENT. SHOP DRAWINGS SHALL INCLUDE ALL PERTINENT INFORMATION REQUIRED FOR THE ENGINEER TO FULLY EVALUATE THE MATERIALS BEING REPRESENTED BY THE SUBMITTAL INCLUDING THE PHYSICAL PROPERTIES, DIMENSIONS, LOCATIONS AND METHOD OF INSTALLATION.
- SHOP DRAWINGS WILL BEAR THE REVIEW STAMP OF THE CONTRACTOR INDICATING THAT HE HAS REVIEWED THE DRAWINGS FOR CONFORMANCE WITH THE CONTRACT DOCUMENTS, COORDINATED ITEMS INCLUDED IN THE SUBMITTAL WITH RELATED ITEMS, AND VERIFIED AND COORDINATED DIMENSIONS.
- REPRODUCTIONS OF THE ENGINEERING DRAWINGS WILL NOT BE ACCEPTABLE AS SHOP DRAWINGS.
- ANY SHOP DRAWING NOT CONFORMING TO THESE REQUIREMENTS WILL BE CAUSE FOR REJECTION AND WILL BE RETURNED WITHOUT ANY FURTHER ACTION.

- IT IS THE OWNERS RESPONSIBILITY TO HIRE A CERTIFIED WIND STORM ENGINEER TO INSPECT THE BUILDING FOR TWI REQUIREMENTS

5. EXCAVATION, BACKFILLING & FOUNDATIONS

- A GEOTECHNICAL EXPLORATION OF SUBSURFACE CONDITIONS, CONTAINING TEST BORINGS, LABORATORY TEST, ENGINEERING ANALYSIS AND FOUNDATION RECOMMENDATIONS, PERFORMED BY HWJ ASSOCIATES, INC. DATED 10/22/16 IS AVAILABLE FOR REVIEW.

- MAINTAIN PROPER SITE DRAINAGE DURING CONSTRUCTION SO THAT PONDING OF WATER DOES NOT OCCUR IN THE BUILDING AREA.

C. SUB-GRADE PREPARATION:

- EXCAVATE EXISTING SOILS AS REQUIRED TO REMOVE ALL EXISTING VEGETATION ROOTS & DELETERIOUS MATERIALS FROM THE PROPOSED BUILDING AREA, & AS REQUIRED BY SOIL REPORT. THE CLEARING SHOULD EXTEND AT LEAST THREE (3) FEET BEYOND THE BUILDING EDGES. ONCE ROUGH GRADE IS ESTABLISHED, THE EXPOSED SURFACE SHOULD BE PROOF-ROLLED IN ACCORDANCE WITH TxDOT ITEM 216 (1993). ANY SOFT POCKETS OF SOFT OR WEAK SOILS ENCOUNTERED SHOULD BE REMOVED. BUILD BUILDING PAD AS REQUIRED BY SOIL REPORT.
- THE MATERIAL USED TO CONSTRUCT THE BUILDING PAD SHOULD CONSIST OF A SELECT NON-ACTIVE, INORGANIC SANDY CLAY TYPE SOIL HAVING A PLASTICITY INDEX (P.I.) OF 25% OR LESS. SELECT FILL MATERIAL SHOULD BE PLACED UNDER LABORATORY CONTROL, IN NO GREATER THAN TEN (10) INCH LOOSE LAYERS, AND COMPACTED TO 95% OF STANDARD PROCTOR DENSITY AS DETERMINED BY ASTM D-698 PROCEDURE, AT OPTIMUM MOISTURE CONTENT (0 TO +3%).

- REFER TO THE GEOTECHNICAL EXPLORATION FOR ADDITIONAL INFORMATION.

ISSUE #	DATE	DESCRIPTION



Boucher Design Group LLC
Members A.I.A.
8802 Maple Ridge, Suite 200
Bellaire, Texas 77401
Tel. 713.785.3644
www.bdgag.com

This document is an instrument of service protected by the copyright law of the United States of America, 17 U.S.C §102, and shall not be copied or reproduced without the express written consent of Boucher Design Group, LLC. 2015

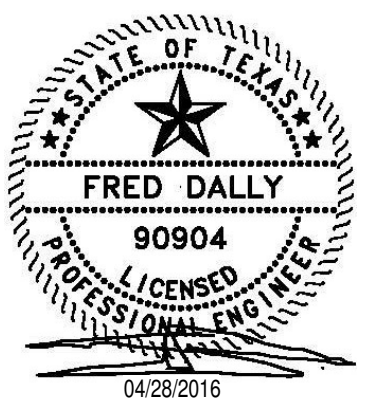

BAYSIDE COMMUNITY CENTER

BACLIFF, TEXAS

GALVESTON COUNTY

DATE	02/29/16
PROJECT NO.	1409000
DRAWN BY	FW
CHECKED BY	FD

GENERAL STRUCTURAL CRITERIA

S101

6. CONCRETE

A. CONCRETE SCHEDULE

BUILDING COMPONENT	28 DAY CYLINDER COMPRESSIVE STRENGTH POUNDS PER SQUARE INCH(P/SI)					
	NORMAL WEIGHT			LIGHT WEIGHT		
	3000	3500	5000	3000	4000	5000
1. DRILLED PIERS	●					
2. SLAB-ON-GRADE	●					
3. GRADE BEAMS AND PLINTHS	●					
4. ALL OTHER CONCRETE	●					

B.

C. PROVIDE DEFORMED NEW BILLET STEEL BARS CONFORMING TO ASTM A615, GRADE 60. ALL REINFORCING STEEL SHALL BE SECURELY HELD IN PLACE; PROVIDE ADDITIONAL BARS OR STIRRUPS FOR SUPPORT AS REQUIRED.

D. WELDED WIRE FABRIC SHALL CONSIST OF FLAT SHEETS AND SHALL CONFORM TO ASTM A185, WITH A MINIMUM YIELD STRENGTH OF 65.0 KSI

E. PROVIDE FULL EMBEDMENT WITH STANDARD 90 DEGREE HOOKS FOR ALL DOWELS. IF NOT OTHERWISE SPECIFIED, THE DOWEL SIZE AND SPACING SHALL BE THE SAME AS THE MAIN REINFORCING.

WHEN REINFORCING STEEL IN GRADE BEAMS, WALLS, SLABS AND BEAMS, IS NOTED AS CONTINUOUS, SPLICE REINFORCING STEEL ONLY WHEN UNAVOIDABLE DUE TO STOCK LENGTHS. STAGGER ALL SPLICES A MINIMUM OF 4'-0". ADJACENT BAR SPLICES ARE NOT ACCEPTABLE. LOCATE THE TOP BAR SPLICES WITHIN THE MIDDLE HALF OF THE SPAN AND LOCATE THE BOTTOM BAR SPLICES AT SUPPORTS OR BETWEEN SUPPORTS AND 1/3 SPAN POINT, UNLESS NOTED OTHERWISE ON PLANS, DETAILS OR SCHEDULES.

PROVIDE INTERIOR AND EXTERIOR HORIZONTAL LAPPED CORNER BARS AT ALL CORNERS TO MATCH THE SIZE, TYPE AND SPACING OF THE WALL AND GRADE BEAM HORIZONTAL REINFORCING.

UNLESS SPECIFICALLY NOTED, SCHEDULED OR DETAILED OTHERWISE, PROVIDE DEVELOPMENT LENGTH FOR REINFORCING IN CONCRETE COMPONENTS IN ACCORDANCE WITH THE SCHEDULE IN NOTE G. BELOW. THIS SCHEDULE SHALL APPLY TO ALL DEVELOPMENT LENGTHS NOT OTHERWISE NOTED, DETAILED OR SCHEDULED IN THE DRAWINGS OR SPECIFICATIONS.

H. REINFORCING BAR DEVELOPMENT LENGTHS (L_d) IN INCHES FOR VARIOUS CONCRETE STRENGTHS IN POUNDS PER SQUARE INCH (PSI). TOP BARS ARE DEFINED AS HORIZONTAL REINFORCING SO PLACED IN A MEMBER THAT MORE THAN 12 INCHES OF CONCRETE IS CAST BELOW THE BAR. ALL OTHER CONDITIONS ARE CONSIDERED BOTTOM BARS FOR DEVELOPMENT AND SPLICE LENGTH PURPOSES.

BAR SIZE GRADE 60	L _d FOR TOP BARS				L _d FOR BOTTOM BARS			
	28 DAY CYLINDER CONCRETE STRENGTH (PSI)				28 DAY CYLINDER CONCRETE STRENGTH (PSI)			
	3000	4000	5000	6000	3000	4000	5000	6000
#3	36	36	17	16	36	36	13	12
#4	36	36	23	21	36	36	17	16
#5	36	36	28	26	36	36	22	20
#6	43	37	34	31	36	36	26	24
#7	63	54	49	45	48	42	38	34
#8	72	62	56	51	55	48	43	39
#9	81	70	62	57	62	54	48	44
#10	89	78	69	63	69	60	53	49
#11	98	85	76	70	76	66	59	54

J. PROVIDE LAP SPLICE LENGTHS FOR REINFORCING BARS 1.3 TIMES THE L_d NOTED IN NOTE H ABOVE.

1. WHEN TWO BARS OF DIFFERENT SIZES ARE LAPPED, THE SMALLER SIZE SHALL GOVERN THE LAP LENGTH UNLESS SPECIFICALLY NOTED.

2. WELDED OR MECHANICAL SPLICES CAPABLE OF DEVELOPING 125% OF THE BAR YIELD STRENGTH MAY BE USED IN LIEU OF THE LAPS. SUCH SPLICES MAY BE EITHER FULL BUTT WELDS OR SERIES 'C' CADWELDS OR EQUAL.

THE GENERAL NOTES, LAP LENGTHS OR DETAILS PERTAINING TO REINFORCING STEEL AS K. SHOWN ON THE DETAIL SHEETS OR OTHER SCHEDULES SHALL SUPERSEDE THE NOTES SHOWN ON THIS SHEET.

PROVIDE THE FOLLOWING COVER FOR CAST-IN-PLACE CONCRETE REINFORCING.

- UNFORMED SURFACES IN CONTACT WITH EARTH: 3 INCHES
- UNFORMED SURFACES OVER MOISTURE BARRIER: 2 INCHES
- FORMED SURFACES EXPOSED TO EARTH OR WEATHER

- #6 AND LARGER: 2 INCHES
- #5 AND SMALLER: 1 1/2" INCHES

- FORMED SURFACES NOT EXPOSED TO EARTH OR WEATHER
- SLABS AND WALLS: 3/4 INCHES
 - BEAMS AND COLUMNS: 1 1/2 INCHES

7. STRUCTURAL STEEL

A. ROLLED SHAPES:

- ALL STRUCTURAL STEEL FOR ALL THE HORIZONTAL FRAMING MEMBER SHALL CONFORM TO ASTM A992, GRADE 50, UNLESS OTHERWISE NOTED
- ALL STRUCTURAL STEEL FOR HOLLOW STRUCTURAL SECTIONS SHALL CONFORM TO ASTM A500, GRADE B, UNLESS OTHERWISE NOTED.
- ALL STRUCTURAL STEEL FOR PIPE SHALL CONFORM TO ASTM A53, TYPE E OR S, GRADE B, UNLESS OTHERWISE NOTED.
- ALL STRUCTURAL STEEL FOR ANGLES, PLATES AND MISCELLANEOUS STEEL SHALL CONFORM TO ASTM A36, UNLESS OTHERWISE NOTED.
- ALL EXPOSED STEEL TO BE GALVANIZED.

B. CONNECTIONS

- PROVIDE STANDARD BOLTED CONNECTIONS CONFORMING TO AISC BOLTED CONNECTIONS, USING ASTM A325 BOLTS, FOR THE BEAM END SHEARS INDICATED IN THE DOCUMENTS. PROVIDE MINIMUM OF TWO BOLTS FOR ALL CONNECTIONS.
- ALL WELDED CONNECTIONS SHALL CONFORM TO AWS UNLESS OTHERWISE NOTED.
- SURVEY ALL PLANS, DETAILS, SECTIONS, SCHEDULES AND SPECIFICATIONS FOR SPECIAL CONNECTIONS.
- UNLESS OTHERWISE NOTED AND/OR SPECIFIED, DESIGN ALL BEAM CONNECTIONS TO SUPPORT 1/2 OF THE TOTAL MEMBER SIZE AND SPAN AS DETERMINED BY THE TABLES FOR ALLOWABLE UNIFORM LOADS ON BEAMS IN THE 9TH EDITION OF THE AISC MANUAL OF STEEL CONSTRUCTION (ALLOWABLE STRESS DESIGN).
- MOMENT CONNECTIONS SHOWN SHALL BE DESIGNED TO FULLY DEVELOP THE SECTION IN FLEXURE AND TO SUPPORT 1/2 THE TOTAL UNIFORM LOAD FOR SHEAR AS DESCRIBED IN NOTE 4 ABOVE.

C. OPEN WEB STEEL JOISTS:

- AS APPLICABLE FOR THE OPEN WEB STEEL JOIST TYPE INDICATED ON THE DRAWINGS, CONFORMING TO SJI OR AISC, WHICHEVER IS MORE STRINGENT.
- PROVIDE JOIST BRIDGING IN ACCORDANCE WITH SJI.
- DESIGN ROOF JOISTS FOR NET UPLIFT PRESSURES OF 20 PSF.

D. STEEL DECK:

TYPE 1

- PROVIDE STEEL ROOF DECK 1 1/2" DEEP TYPE B 20 GAUGE STEEL SHEETS AND CONFORMING TO ASTM A653, STRUCTURAL STEEL (SS), GRADE 33, GALVANIZED COATING DESIGNATION G60.
- PROVIDE STEEL ROOF DECK WITH THE FOLLOWING MINIMUM SECTION PROPERTIES:

- MOMENT OF INERTIA: I ≥ 0.201 INCHES⁴ /FOOT WIDTH
- SECTION MODULUS: S_x ≥ 0.234 INCHES³ /FOOT WIDTH
- SECTION MODULUS: S_y ≥ 0.247 INCHES³ /FOOT WIDTH

- ATTACH STEEL ROOF DECK TO STEEL SUPPORTS AND AT SIDE LAPS AS FOLLOWS:

POWDER-ACTUATED FASTENERS:
SUPPORTS: "HLTI" X-EDNK22 THQ12 AND "HLTI" X-ENP-19L15, 36/7 PATTERN
SIDELAPS: #10 "TEK" @ 9" O.C. MAXIMUM

SCREWS:
SUPPORTS: #12 "TEK" SCREWS, 36/7 PATTERN
SIDELAPS: #10 "TEK" @ 9" O.C. MAXIMUM

8. INDEPENDENT TESTING LABORATORY

A. A GEOTECHNICAL EXPLORATION OF SUBSURFACE CONDITIONS, CONTAINING TEST BORINGS, LABORATORY TEST, ENGINEERING ANALYSIS AND FOUNDATION RECOMMENDATIONS, PERFORMED BY bdg, REPORT NO. 14-S-3376, DATED bdg, IS AVAILABLE FOR REVIEW.

B. EMPLOYMENT OF A TESTING LABORATORY IN NO WAY RELIEVES THE CONTRACTOR OF ANY OBLIGATION TO PERFORM WORK IN ACCORDANCE WITH THE CONTRACT DOCUMENTS.

C. CONTRACTOR RESPONSIBILITIES:

- DELIVER TO LABORATORY AT DESIGNATED LOCATION ADEQUATE SAMPLES OF MATERIALS PROPOSED TO BE USED WHICH REQUIRE TESTING, TOGETHER WITH PROPOSED MIX DESIGNS.
- COOPERATE WITH LABORATORY PERSONNEL AND PROVIDE ACCESS TO WORK AND TO MANUFACTURER'S FACILITIES.
- PROVIDE INCIDENTAL LABOR AND FACILITIES TO PROVIDE ACCESS TO WORK TO BE TESTED, TO OBTAIN AND HANDLE SAMPLES AT THE SITE OR AT SOURCE OF PRODUCTS TO BE TESTED, TO FACILITATE TEST AND INSPECTIONS AND FOR STORAGE AND CURING OF TEST SAMPLES.
- NOTIFY LABORATORY OF MATERIAL SOURCES AND FURNISH NECESSARY QUANTITIES OF REPRESENTATIVE SAMPLES OF MATERIALS PROPOSED FOR USE WHICH ARE REQUIRED TO BE TESTED.
- NOTIFY ARCHITECT AND LABORATORY 24 HOURS PRIOR TO EXPECTED TIME FOR OPERATIONS REQUIRING INSPECTION AND TESTING SERVICES.
- ADVISE LABORATORY IN A TIMELY FASHION TO COMPLETE REQUIRED INSPECTION AND TESTING PRIOR TO SUBSEQUENT WORK BEING PERFORMED.
- PAY FOR ALL SUBSEQUENT RE-TESTING OF PRODUCTS OR SYSTEMS FOUND TO BE DEFECTIVE OR OTHERWISE NOT IN ACCORDANCE WITH SPECIFICATION REQUIREMENTS. REMOVE REJECTED PRODUCTS AND REPLACE WITH PRODUCTS OF SPECIFIED QUALITY.

D. INDIVIDUAL TEST AND SPECIAL INSPECTIONS REQUIRED:

- SOIL COMPACTION TESTS.
- SPREAD FOOTING BEARING STRATA CONFIRMATION, INSPECTION AND TESTS
- CONCRETE COMPRESSIVE STRENGTH TESTS
- CONCRETE SLUMP TESTS
- CONCRETE AIR CONTENT TESTS
- LIGHT WEIGHT CONCRETE PULL TESTS
- STRUCTURAL STEEL FIELD WELD INSPECTION AND TESTS. INSPECT AND TEST 100% OF FULL PENETRATION WELDS.
- STRUCTURAL STEEL BOLTED AND HIGH STRENGTH BOLTED CONNECTION INSPECTION AND TESTS
- STEEL JOIST FIELD WELD INSPECTION
- STEEL DECK FIELD WELD AND ATTACHMENT INSPECTION

E. ADDITIONAL TESTS AT THE CONTRACTOR'S EXPENSE WILL BE PERFORMED TO DETERMINE COMPLIANCE OF REPLACED OR ADDITIONAL WORK WITH SPECIFIED REQUIREMENTS.

CORRECT DEFICIENCIES IN WORK THAT TEST REPORTS AND INSPECTIONS INDICATE DO NOT COMPLY WITH THE CONTRACT DOCUMENTS.

PROVIDE THE ENGINEER OF RECORD (EOR) COPIES OF ALL SPECIAL INSPECTIONS SO A SPECIAL INSPECTIONS REPORT CAN BE PREPARED FOR OBTAINING A CERTIFICATE OF OCCUPANCY.

ISSUE #	DATE	DESCRIPTION
△	03-23-2016	ADDENDUM 3



Boucher Design Group LLC
Members A.I.A.
6802 Mapleridge, Suite 200
Bellaire, Texas 77401
Tel. 713.785.3644
www.bdgap.com

This document is an instrument of service protected by the copyright law of the United States of America, 17 U.S.C §102, and shall not be copied or reproduced without the express written consent of Boucher Design Group, LLC. 2015



BAYSIDE COMMUNITY CENTER

BACLIFF, TEXAS

GALVESTON COUNTY

DATE	02/29/16
PROJECT NO.	1409000
DRAWN BY	RW
CHECKED BY	FD

GENERAL STRUCTURAL CRITERIA

S102

© COPYRIGHT 2016 BOUCHER DESIGN GROUP, LLC

ISSUE #	DATE	DESCRIPTION
1	03-23-2016	ADDENDUM 3
2	04-22-2016	ADDENDUM 4

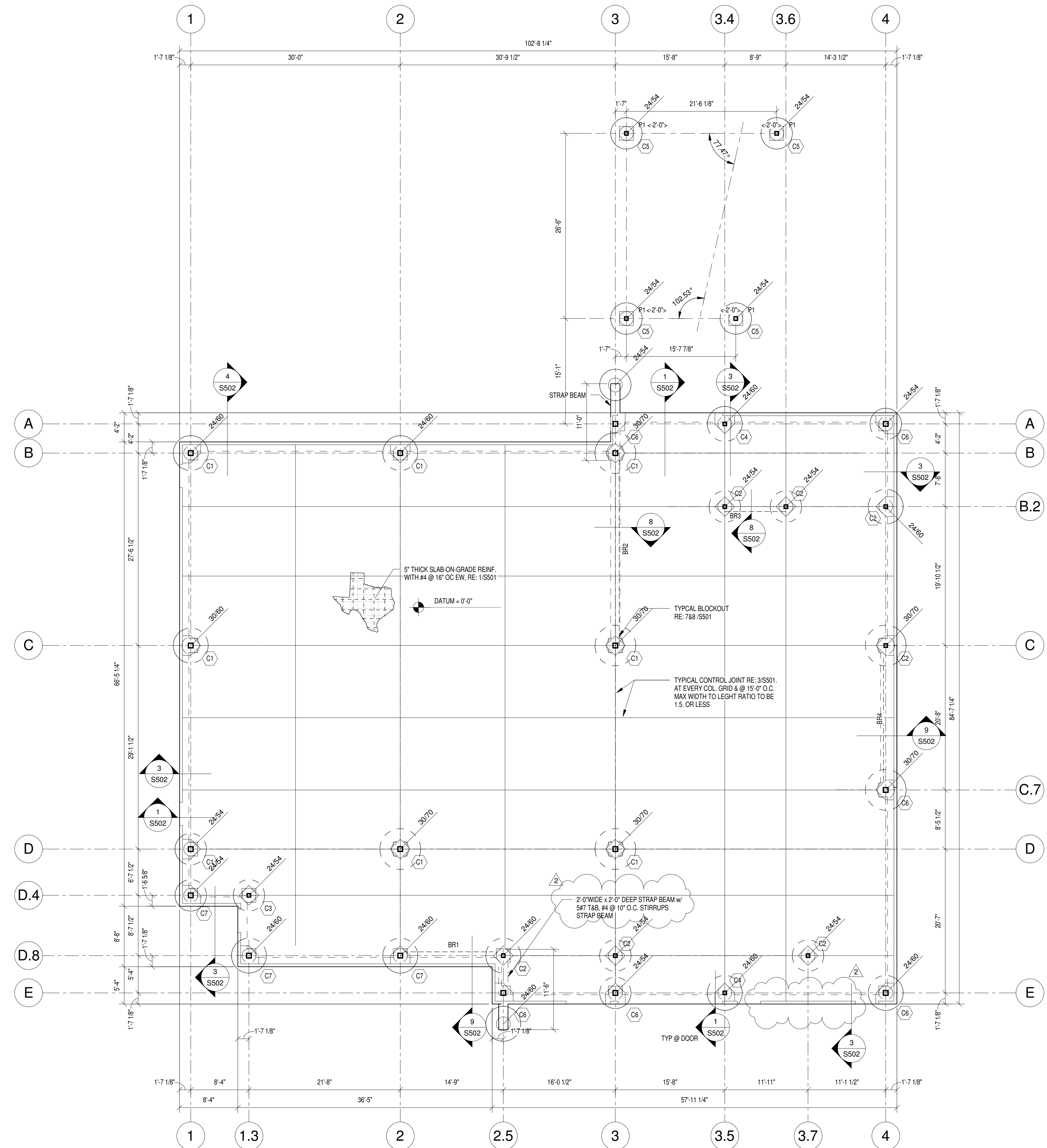

- FOUNDATION NOTES:**
- DATUM ELEVATION -0'-0" CORRESPONDS TO TRUE ELEVATION - RE: CIVIL. ALL ELEVATIONS ARE RELATIVE TO DATUM ELEVATION -0'-0".
 - ALL INTERIOR PLINTHS ARE TYPE "P1" UON, ALL PERIMETER PLINTHS ARE TYPE "P2" UON, ALL CORNER PLINTHS ARE TYPE "P3" UON, T.O. PLINTHS ARE AT - 0'-8" TYP. UON, FOR PLINTH AND PIER SCHEDULE & DETAILS RE: S301.
 - TOP OF ALL INTERIOR/EXTERIOR PIERS ARE AT ELEVATION - 2'-8" UON.
 - FOR COLUMN, BASE PLATE & ANCHOR BOLT SCHEDULE RE: S302
 - TYPICAL LIGHT-POLE FOUNDATION DETAIL RE: 1&5/S501.
 - DURING PIERS DRILLING IN CASE GC FINDS WATER GC TO PROVIDE CASING. GC TO PROVIDE A UNIT PRICE FOR CASING.
 - DURING PIERS DRILLING IN CASE OF HITTING SAND, OR IN CASE OF UNDERREAMED BELL COLLAPSE. GC TO DRILL STRAIGHT SHAFT PIER WITH DIAMETER EQUAL TO ORIGINAL BELL DIAMETER WITH 0.5% REINFORCING FOR THE NEW DIAMETER.

1 Foundation Plan
1/8" = 1'-0"

C:\Users\juser\Desktop\Local Files\2016\15-124-00 Bayshore Community Center_TCK.vrt 5/17/2016 8:09:23 AM

bdg
architecture
+ planning
boucher design group

Boucher Design Group LLC
Members A.I.A.
6802 Mapleridge, Suite 200
Bellaire, Texas 77401
Tel. 713.785.3644
www.bdgap.com

This document is an instrument of service protected by the copyright law of the United States of America, 17 U.S.C §102, and shall not be copied or reproduced without the express written consent of Boucher Design Group, LLC. 2015



BAYSIDE COMMUNITY CENTER	
BACLIFF, TEXAS	
GALVESTON COUNTY	
DATE	02/29/16
PROJECT NO.	1409000
DRAWN BY	Author
CHECKED BY	Checker

FOUNDATION PLAN

ISSUE #	DATE	DESCRIPTION
1	03-23-2016	ADDENDUM 3

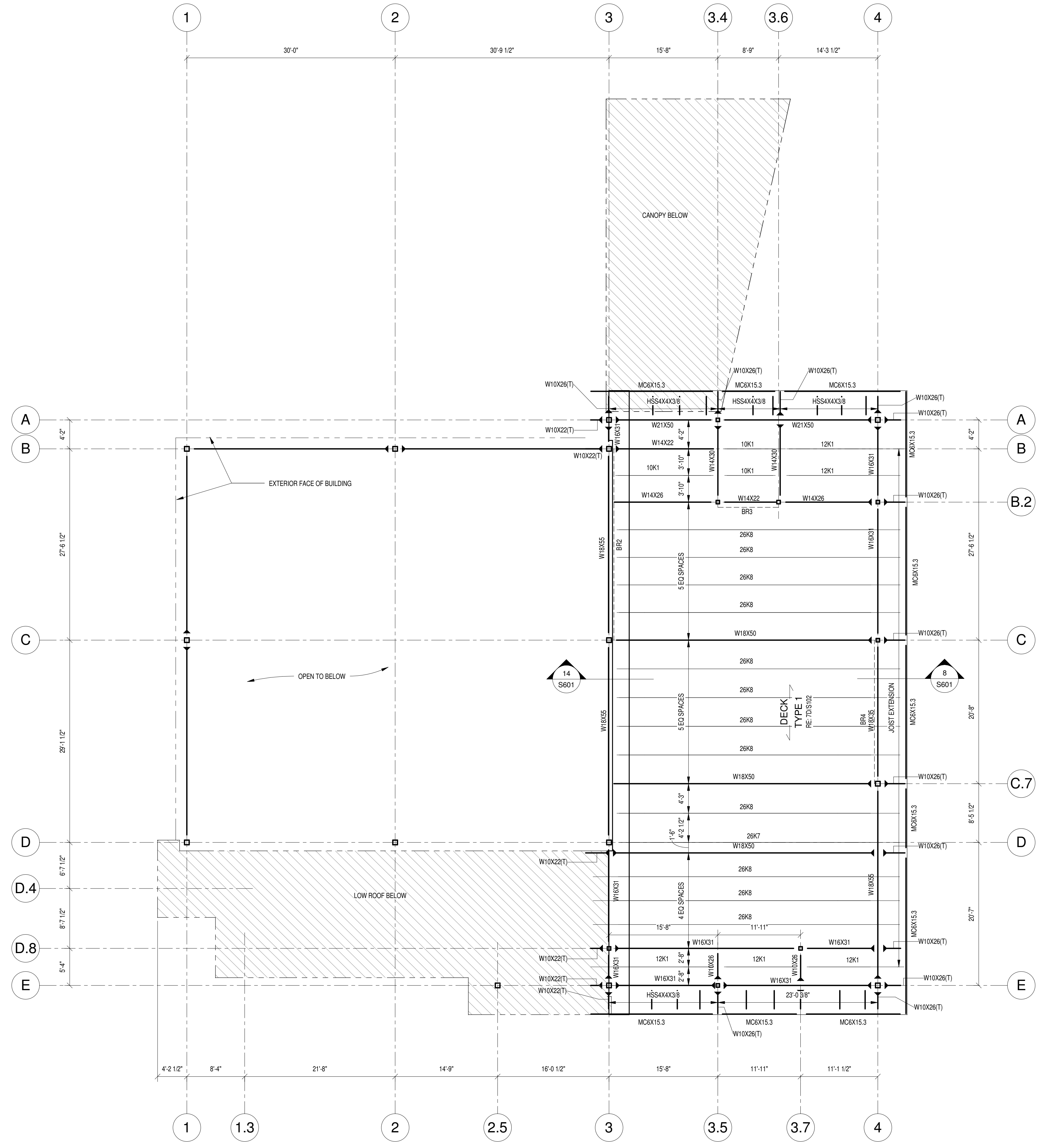

- STEEL FRAMING PLAN NOTES:**
- ALL ELEVATIONS ARE RELATIVE TO DATUM ELEVATION.
 - T.O. STEEL ELEVATION AT DECK TYPE 1 IS AT B.O. DECK, UON. FOR DECK TYPE INFORMATION RE: 7D/S102.
 - COORDINATE LOCATIONS AND SIZES OF ALL CHASES AND PENETRATIONS WITH MEP. COORDINATE EXACT LOCATION OF ALL MEP UNITS WITH MEP. FOR FRAMING AROUND ROOF OPENING RE: S701.
 - ALL BRACES ARE HSS6X6X3/8 TYP. UON.
 - THE BOTTOM FLANGE OF ALL CANTILEVER AND MOMENT BEAMS MUST BE KICKED W/ L3X3X1/4 @ 2'-0" OC TO THE BOTTOM OF DECK OR ADJACENT BEAM/JOIST.
 - JOIST GIRDER IS DESIGNED USING ASD TABLE.
 - (T) INDICATES TAPERED WIDE FLANGE BEAM.
 - ALL HSS TUBES ARE (LLV) TYP. UON.
 - ALL EXPOSED STEEL TO BE GALVANIZED

1 Roof Framing Plan
1/8" = 1'-0"

bdg
architecture
+ planning
boucher design group

Boucher Design Group LLC
Members A.I.A.
6802 Mapleridge, Suite 200
Bellaire, Texas 77401
Tel. 713.785.3644
www.bdgap.com

This document is an instrument of service protected by the copyright law of the United States of America, 17 U.S.C §102, and shall not be copied or reproduced without the express written consent of Boucher Design Group, LLC. 2015

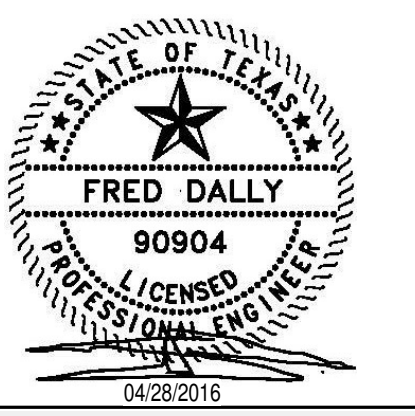

BAYSIDE COMMUNITY CENTER
BACLIFF, TEXAS
GALVESTON COUNTY

DATE	02/29/16
PROJECT NO.	1409000
DRAWN BY	Author
CHECKED BY	Checker

ROOF FRAMING PLAN

C:\Users\User\Desktop\Local Files\2015\15-124-00 Bayshore Community Center_TCK.rvt 5/17/2016 8:09:24 AM

ISSUE #	DATE	DESCRIPTION
1	03-23-2016	ADDENDUM 3

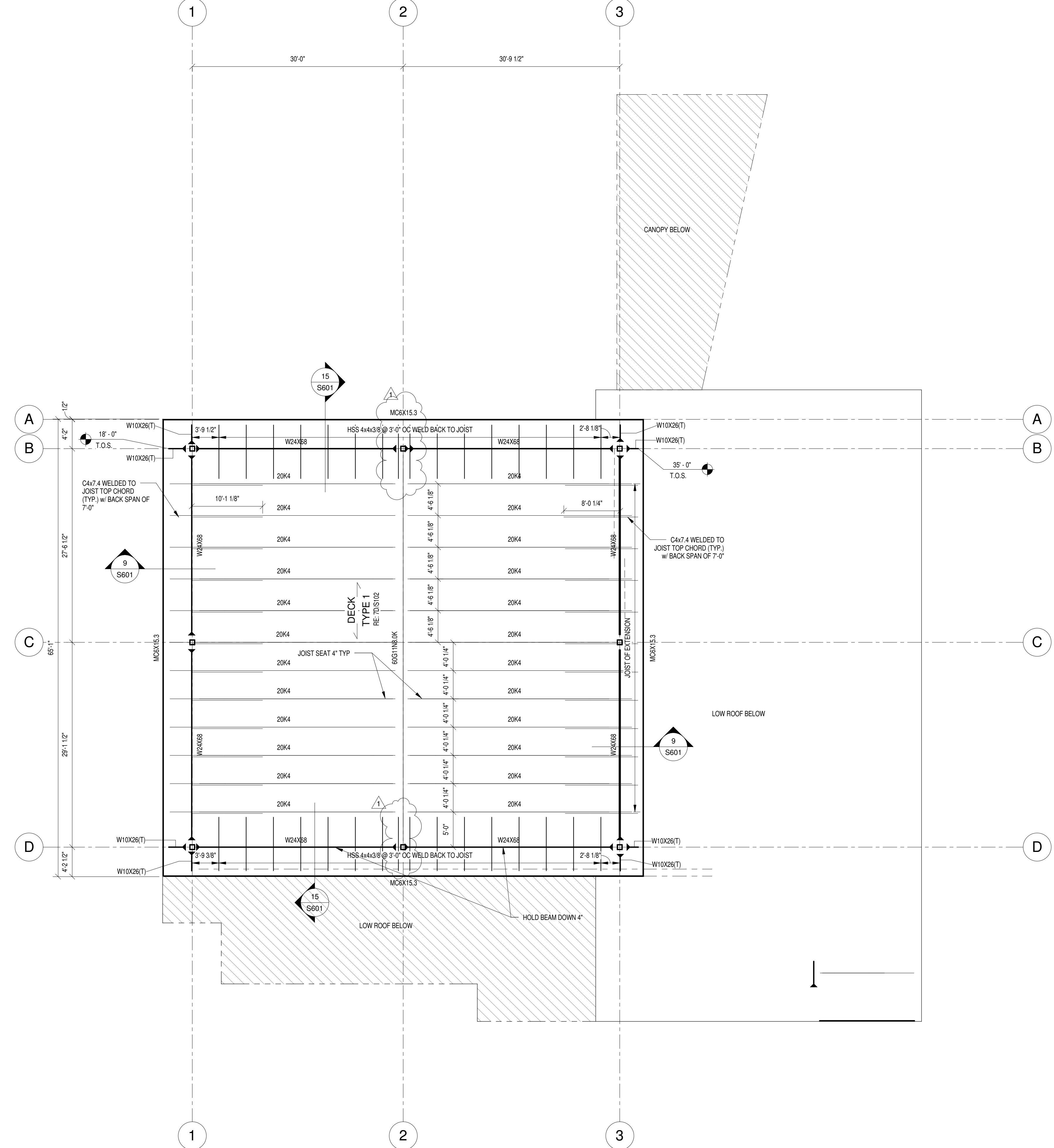

- STEEL FRAMING PLAN NOTES:**
- ALL ELEVATIONS ARE RELATIVE TO DATUM ELEVATION.
 - T.O. STEEL ELEVATION AT DECK TYPE 1 IS AT B.O. DECK, UON. FOR DECK TYPE INFORMATION RE: 7D/S102.
 - COORDINATE LOCATIONS AND SIZES OF ALL CHASES AND PENETRATIONS WITH MEP. COORDINATE EXACT LOCATION OF ALL MEP UNITS WITH MEP. FOR FRAMING AROUND ROOF OPENING RE: S701.
 - ALL BRACES ARE HSS6X6X3/8 TYP. UON.
 - THE BOTTOM FLANGE OF ALL CANTILEVER AND MOMENT BEAMS MUST BE KICKED W/ L3X3X1/4 @ 2'-0" OC TO THE BOTTOM OF DECK OR ADJACENT BEAM/JOIST.
 - JOIST GIRDER IS DESIGNED USING ASD TABLE.
 - (T) INDICATES TAPERED WIDE FLANGE BEAM.
 - ALL HSS TUBES ARE (LLV) TYP. UON.
 - ALL EXPOSED STEEL TO BE GALVANIZED

1 High Roof Framing Plan
1/8" = 1'-0"

bdg
architecture
+ planning
boucher design group

Boucher Design Group LLC
Members A.I.A.
6802 Mapleridge, Suite 200
Bellaire, Texas 77401
Tel. 713.785.3644
www.bdgap.com

This document is an instrument of service protected by the copyright law of the United States of America, 17 U.S.C §102, and shall not be copied or reproduced without the express written consent of Boucher Design Group, LLC. 2015



BAYSIDE COMMUNITY CENTER	
BACLIFF, TEXAS	
GALVESTON COUNTY	
DATE	02/29/16
PROJECT NO.	1409000
DRAWN BY	Author
CHECKED BY	Checker

HIGH ROOF FRAMING PLAN

C:\Users\User\Desktop\Local Files\2015\15-124-00 Bayshore Community Center_TCK.vrt
5/17/2016 8:09:25 AM

ISSUE #	DATE	DESCRIPTION

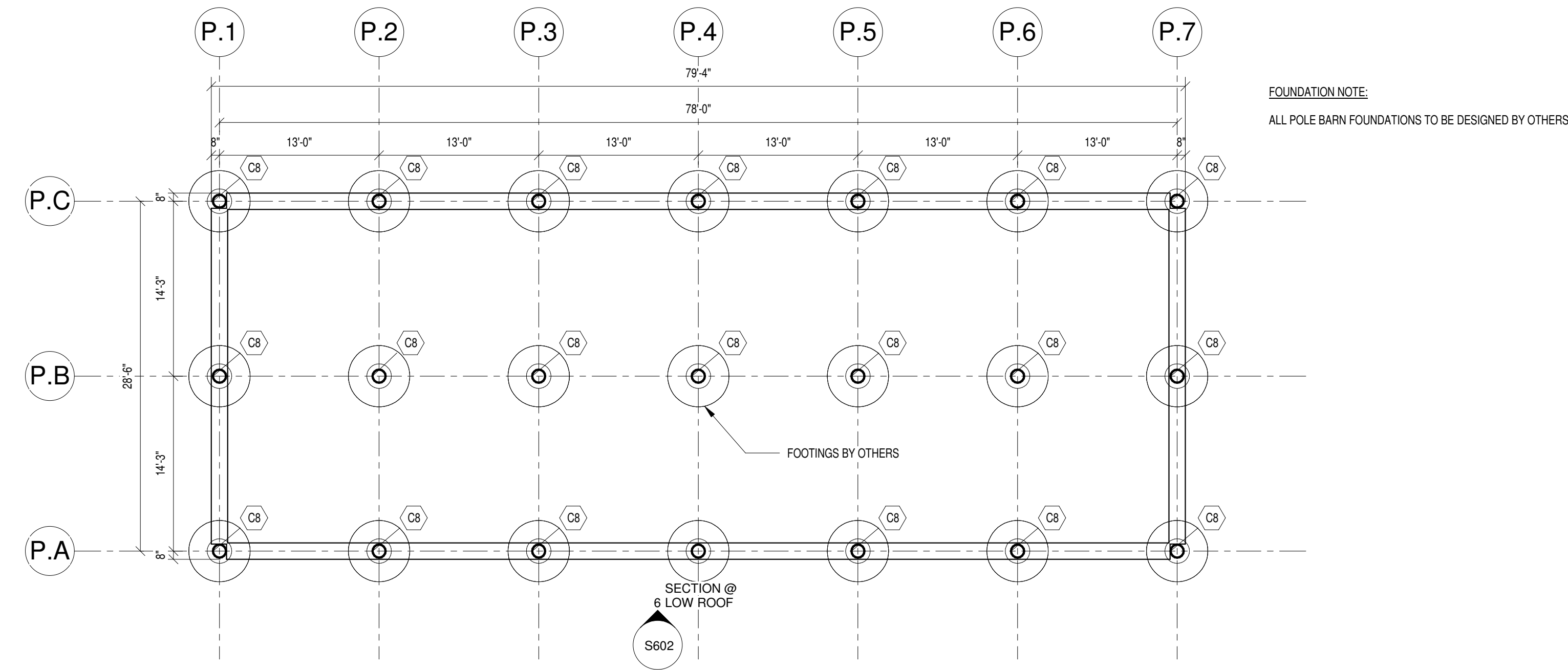

1 POLE BARN FOUNDATION PLAN
1/8" = 1'-0"

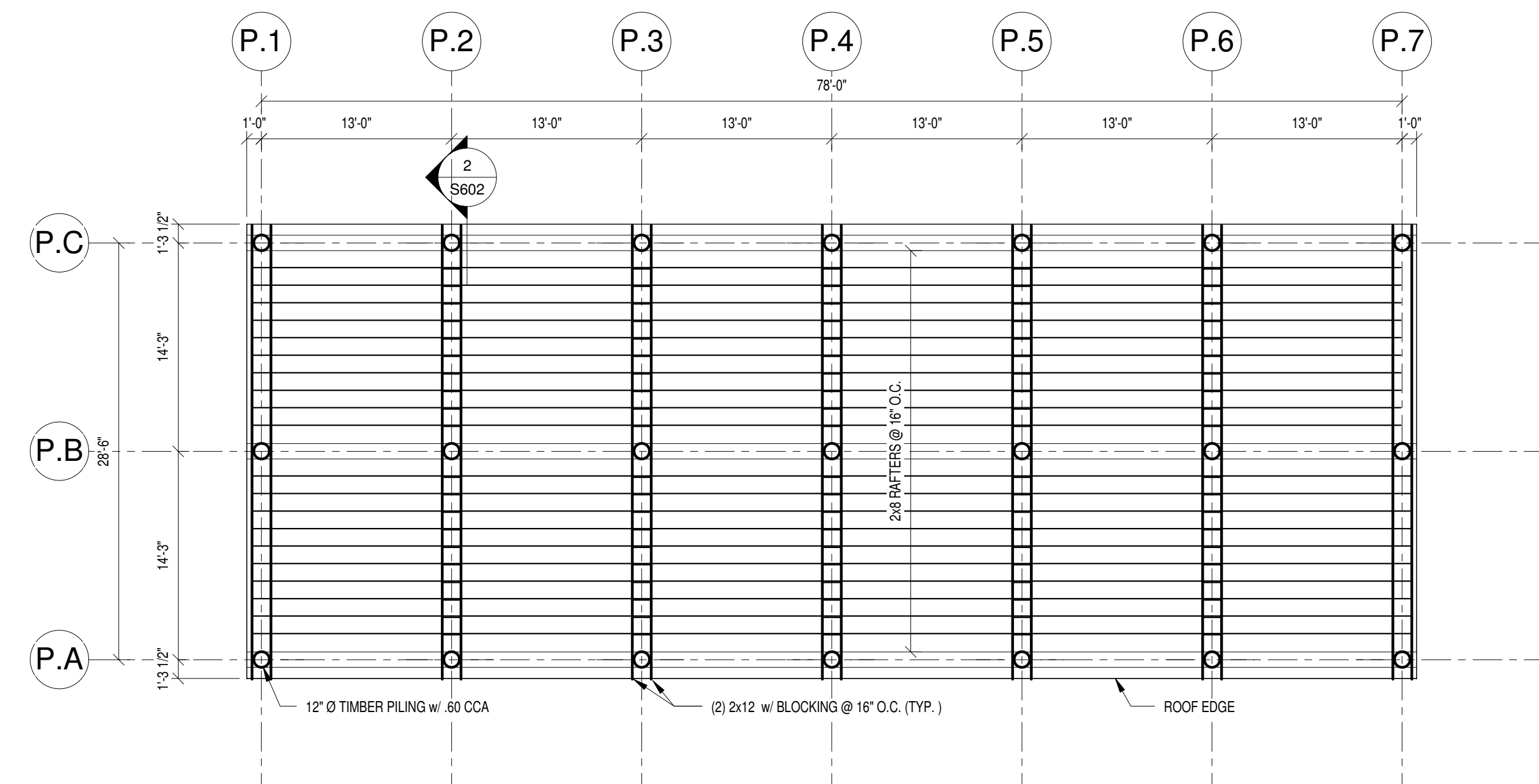

2 Pole Barn Framing Plan
1/8" = 1'-0"



Boucher Design Group LLC
Members A.I.A.
6802 Mapleridge, Suite 200
Bellaire, Texas 77401
Tel. 713.785.3644
www.bdgap.com

This document is an instrument of service protected by the copyright law of the United States of America, 17 U.S.C §102, and shall not be copied or reproduced without the express written consent of Boucher Design Group, LLC. 2015



BAYSIDE COMMUNITY CENTER

BACLIFF, TEXAS

GALVESTON COUNTY

DATE	02/29/16
PROJECT NO.	1409000
DRAWN BY	Author
CHECKED BY	Checker

POLE BARN PLANS

S205

© COPYRIGHT 2016 BOUCHER DESIGN GROUP, LLC

1. STRUCTURAL STEEL COLUMN SCHEDULE AND DETAILS

LEVEL	COLUMN MARK	C1	C2	C3	C4	C5	C6	C7	C8	C9	C10	C11	C12
CAP PLATE DETAIL		A/S302	A/S302	A/S302	A/S302	A/S302	A/S302	A/S302	A/S302	A/S302	A/S302	A/S302	A/S302
ROOF -R3>	B.O.D. ELEVATION = RE: PLAN												
ROOF -R2>	B.O.D. ELEVATION = RE: PLAN												
ROOF -R1>	B.O.D. ELEVATION = RE: PLAN												
CANOPY <C1>	B.O.D. ELEVATION = RE: PLAN												
F.F.E. = 0'-0"													
BOTTOM OF BASE PLATE EL		-6 1/2"	-6 1/2"	-6 1/2"	-6 1/2"	-6 1/2"	-6 1/2"	-6 1/2"					
BASE PLATE MARK		BP1	BP2	BP2	BP2	BP2	BP1	BP1					
REMARKS													

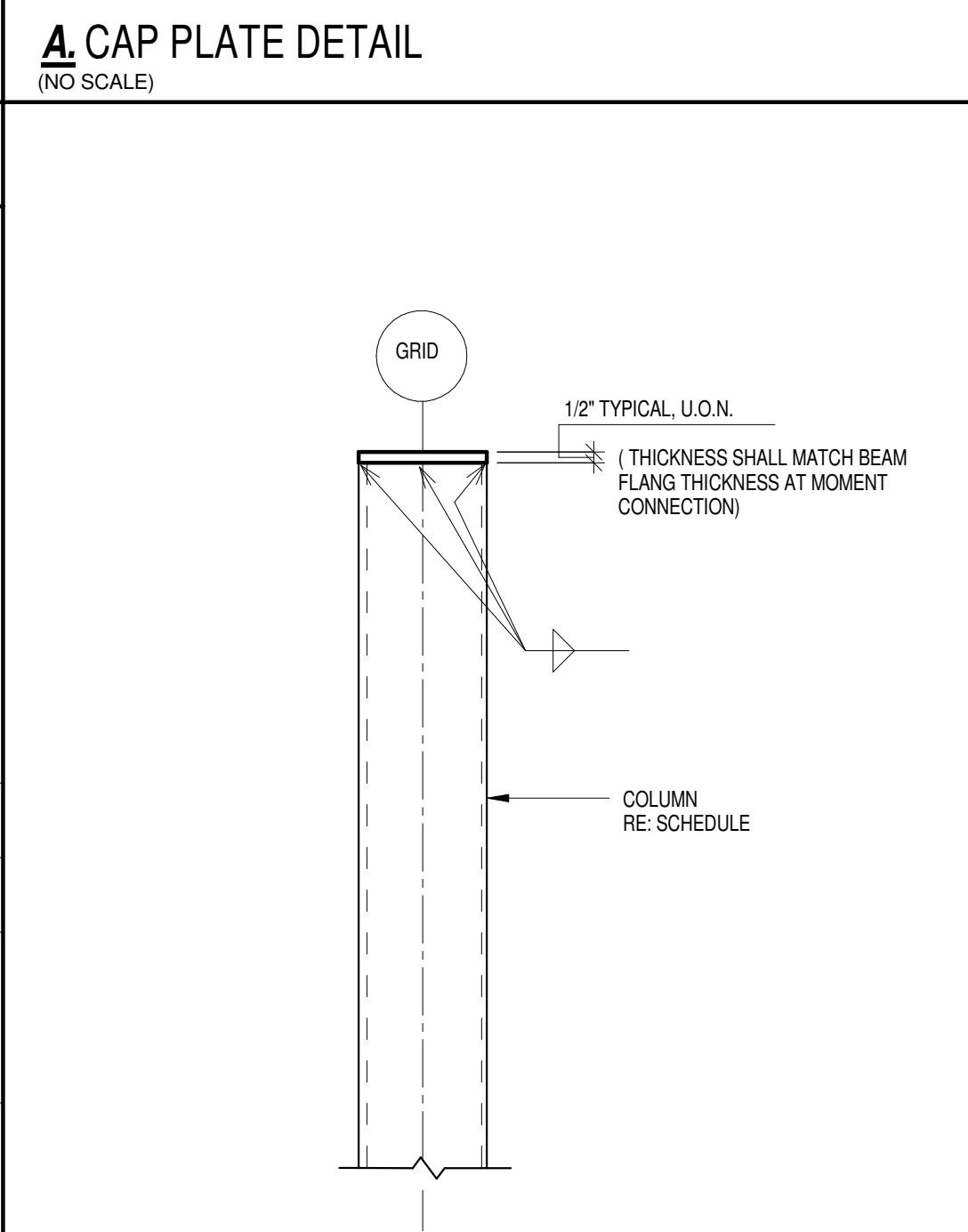

- ### B. COLUMN GENERAL NOTES
1. PROVIDE STRUCTURAL STEEL FOR W SHAPES CONFORMING TO ASTM 992, GRADE 50.
 2. PROVIDE STRUCTURAL STEEL FOR HSS COLUMNS CONFORMING TO ASTM A500, GRADE B.
 3. PROVIDE STEEL FOR STIFFENER PLATES, CONNECTION PLATES AND ANGLES CONFORMING TO ASTM A36.
 4. SAW OR MILL SURFACES NOTED FIN. (FINISHED) FOR TRUE AND FULL CONTACT.
 5. USE E70XX WELDING ELECTRODES FOR ALL WELDS, UNLESS OTHERWISE NOTED.
 6. WEB DOUBLER PLATES ARE NOT REQUIRED.

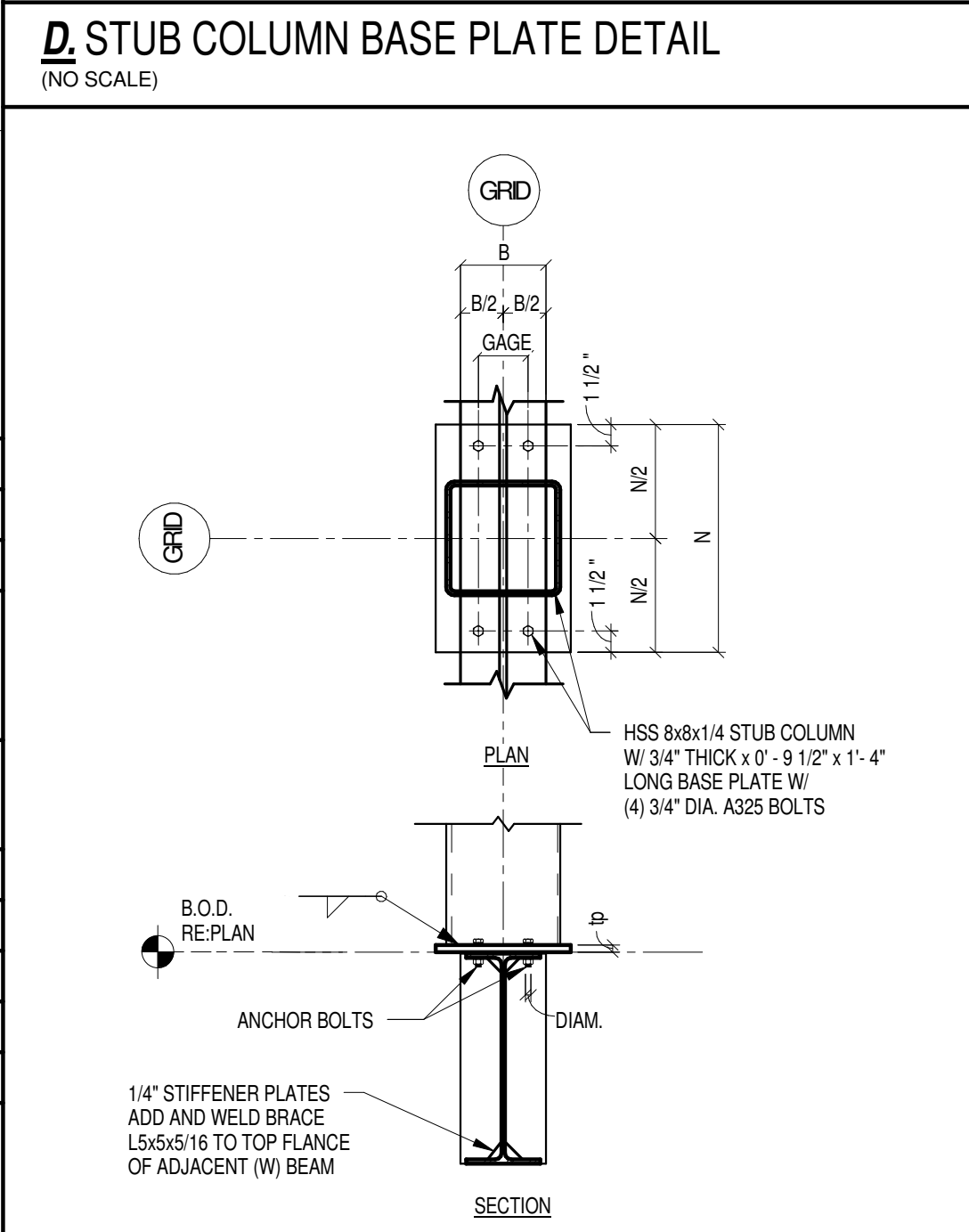

- ### E. BASE PLATE GENERAL NOTES
1. PROVIDE STEEL FOR BASE PLATES CONFORMING TO ASTM A36.
 2. PROVIDE HOLES IN BASE PLATES IN ACCORDANCE WITH AISC 13th EDITION.
 3. PROVIDE ANCHOR RODS CONFORMING TO ASTM F1554, GRADE 55 WELDABLE.
 4. PROVIDE ANCHOR RODS WITH PLATE WASHERS AND HEX NUTS.
 5. USE E70XX WELDING ELECTRODES FOR ALL WELDS, UNLESS OTHERWISE NOTED.
 6. MILL SURFACES NOTED FIN. (FINISHED) FOR TRUE AND FULL CONTACT.
 7. SET ANCHOR RODS WITH TEMPLATE.
 8. PROVIDE NON-METALLIC SHRINK-RESISTANT GROUT WITH 8000 PSI MINIMUM COMPRESSIVE STRENGTH AT 28-DAYS.

2. BASE PLATE SCHEDULE AND DETAILS

MARK	PLATE TYPE	DIMENSIONS			ANCHOR RODS				WELD SIZE	REMARKS
		B (IN)	N (IN)	lp (IN)	NUMBER	DIA. (IN)	PROJECTION, P (IN)	LENGTH, L (IN)	W (IN)	
BP1	A	18	18	1 1/2"	4	1 1/4"	6	2'-0"	5/16	
BP2	A	16	16	1 1/2"	4	1 1/4"	6	2'-0"	5/16	
BP3	B	16	26	1 1/2"	6	1"	6	2'-0"	5/16	FOR COLUMN 6x6 @ WIND BRACING
BP3 AS	B	18	28	1 1/2"	6	1"	6	2'-0"	5/16	FOR COLUMN 8x8 @ WIND BRACING

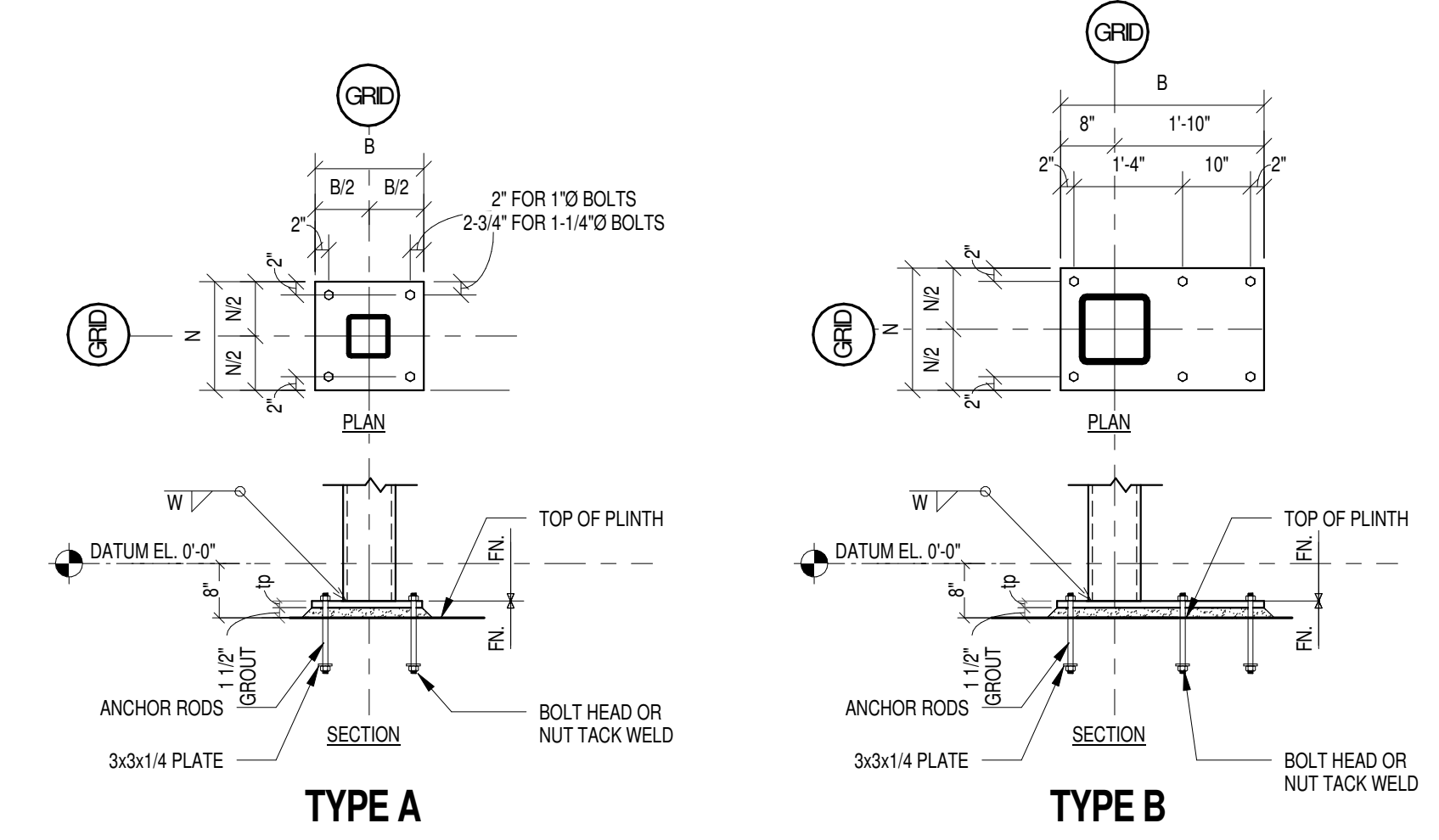

E. MOMENT CONNECTION DETAILS (NO SCALE)

SEE 7/S701

ISSUE #	DATE	DESCRIPTION

Boucher Design Group LLC
Members A.I.A.
6802 Mapleridge, Suite 200
Bellaire, Texas 77401
Tel. 713.785.3644
www.bdgap.com

This document is an instrument of service protected by the copyright law of the United States of America, 17 U.S.C §102, and shall not be copied or reproduced without the express written consent of Boucher Design Group, LLC. 2015



BAYSIDE COMMUNITY CENTER	
BACLIFF, TEXAS	
GALVESTON COUNTY	
DATE	02/29/16
PROJECT NO.	1409000
DRAWN BY	RW
CHECKED BY	FD

COLUMN SCHEDULE

S302

© COPYRIGHT 2016 BOUCHER DESIGN GROUP, LLC

ISSUE #	DATE	DESCRIPTION

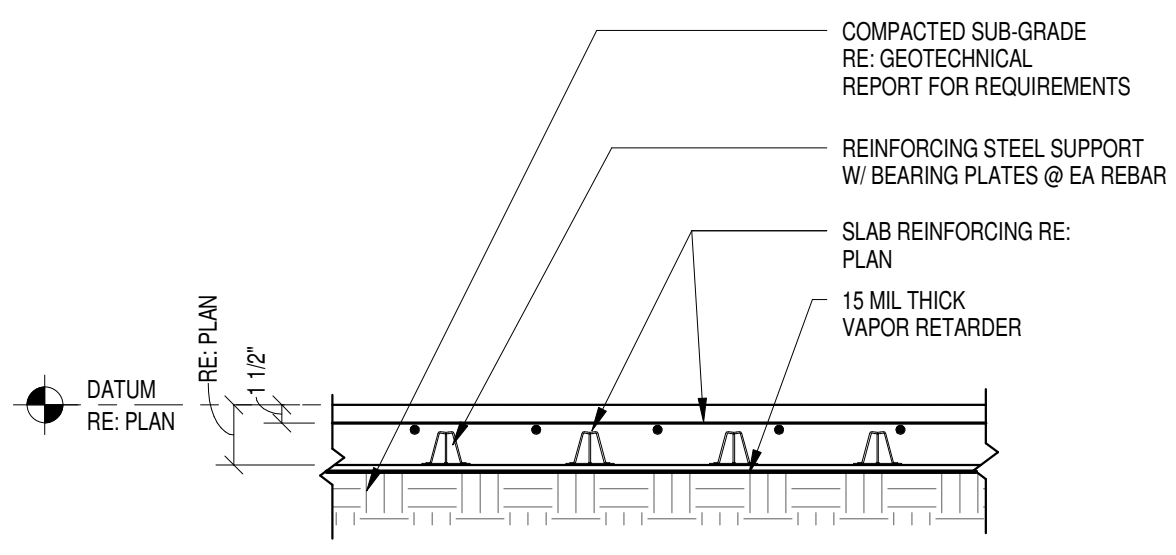

1 TYPICAL SLAB DETAIL
3/4" = 1'-0"

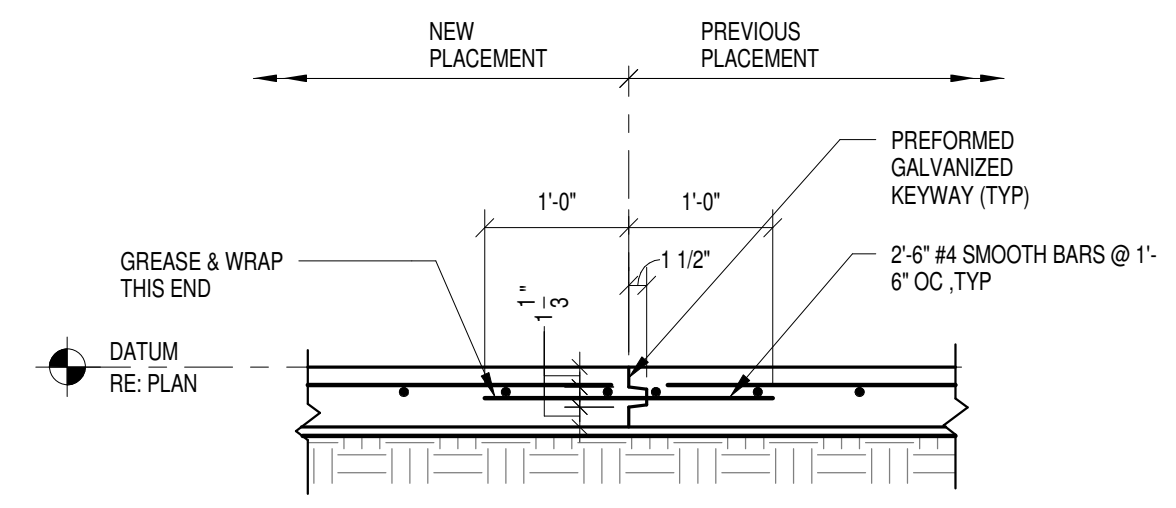

2 TYPICAL CONSTRUCTION SLAB JOINT
3/4" = 1'-0"

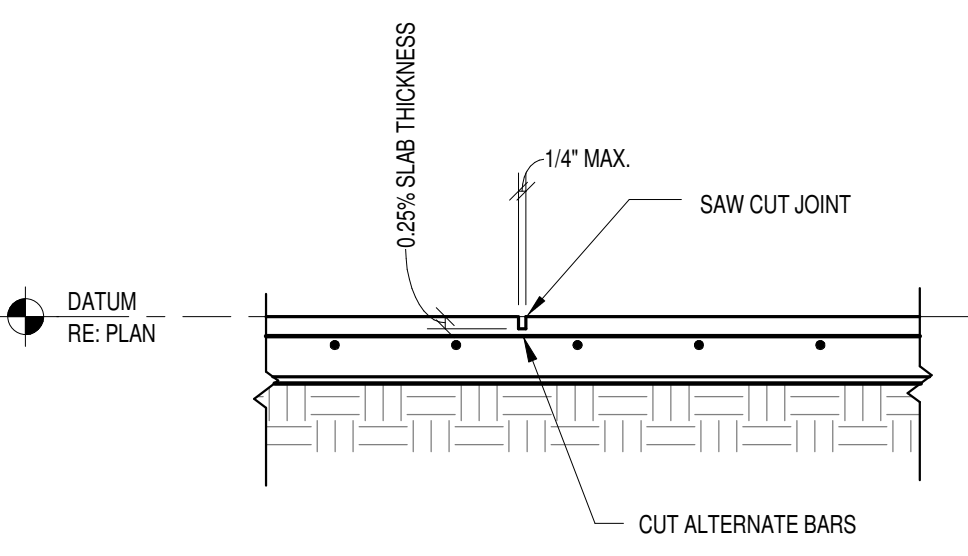

3 TYPICAL SLAB CONTROL JOINT
3/4" = 1'-0"

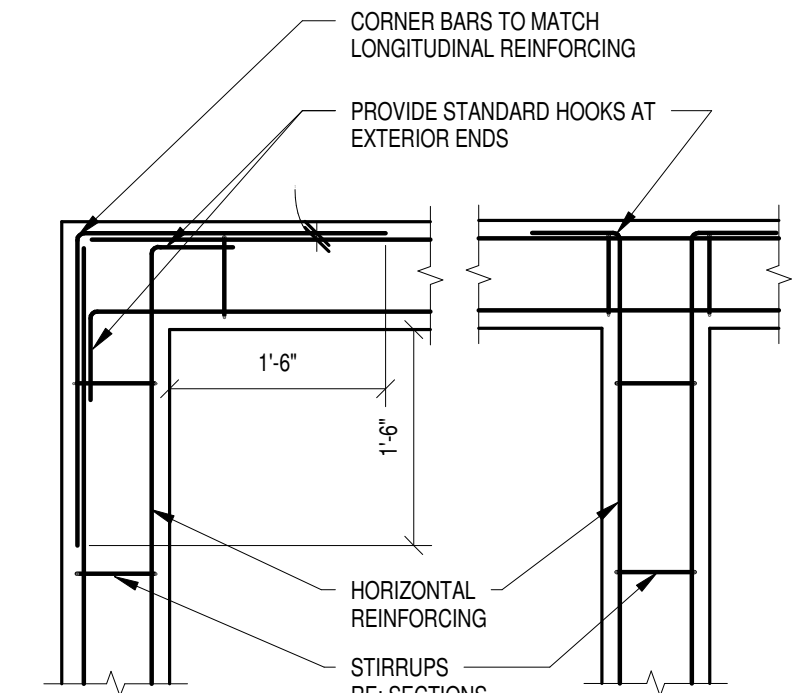

4 TYPICAL GRADE BEAM PLAN
3/4" = 1'-0"

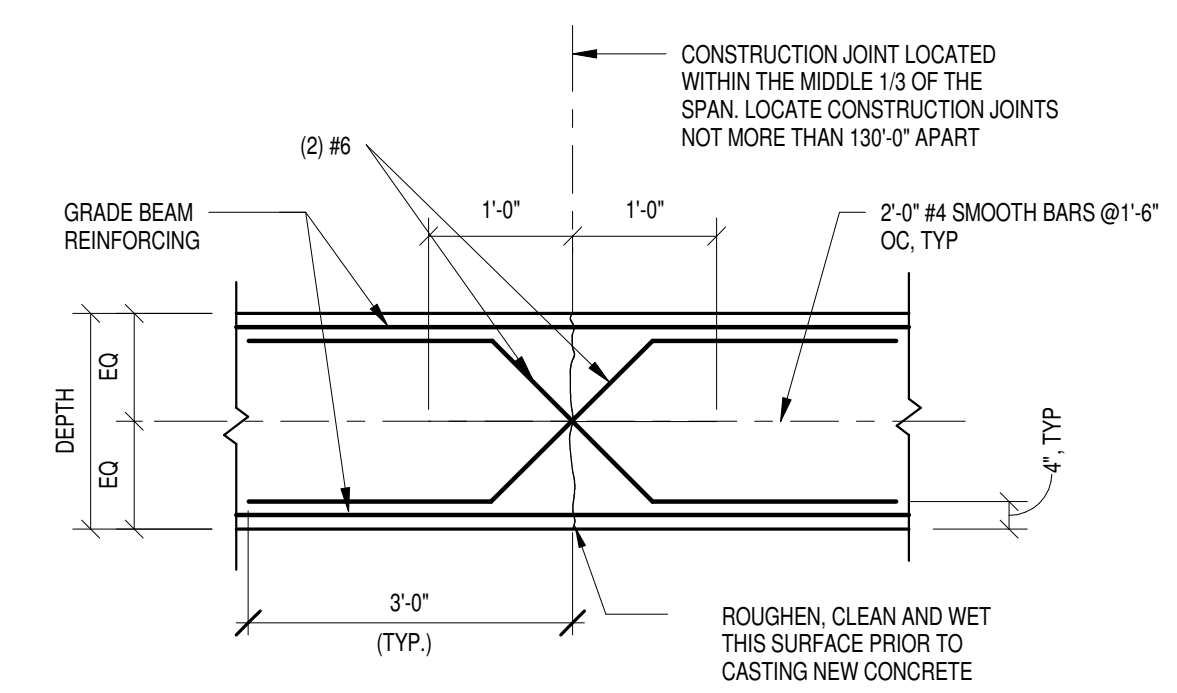

5 TYP. GRADE BEAM CONSTRUCTION JOINT
3/4" = 1'-0"

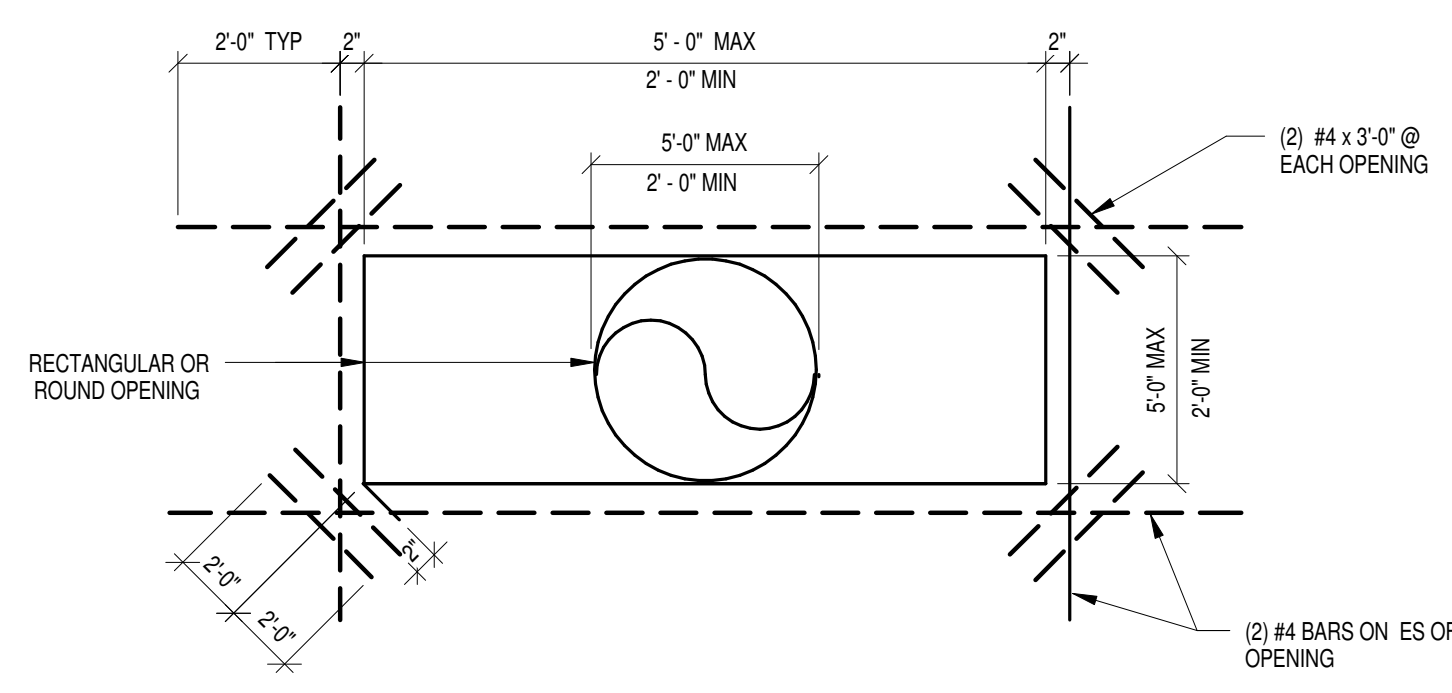

16 TYPICAL OPENING IN SLAB ON GRADE
3/4" = 1'-0"

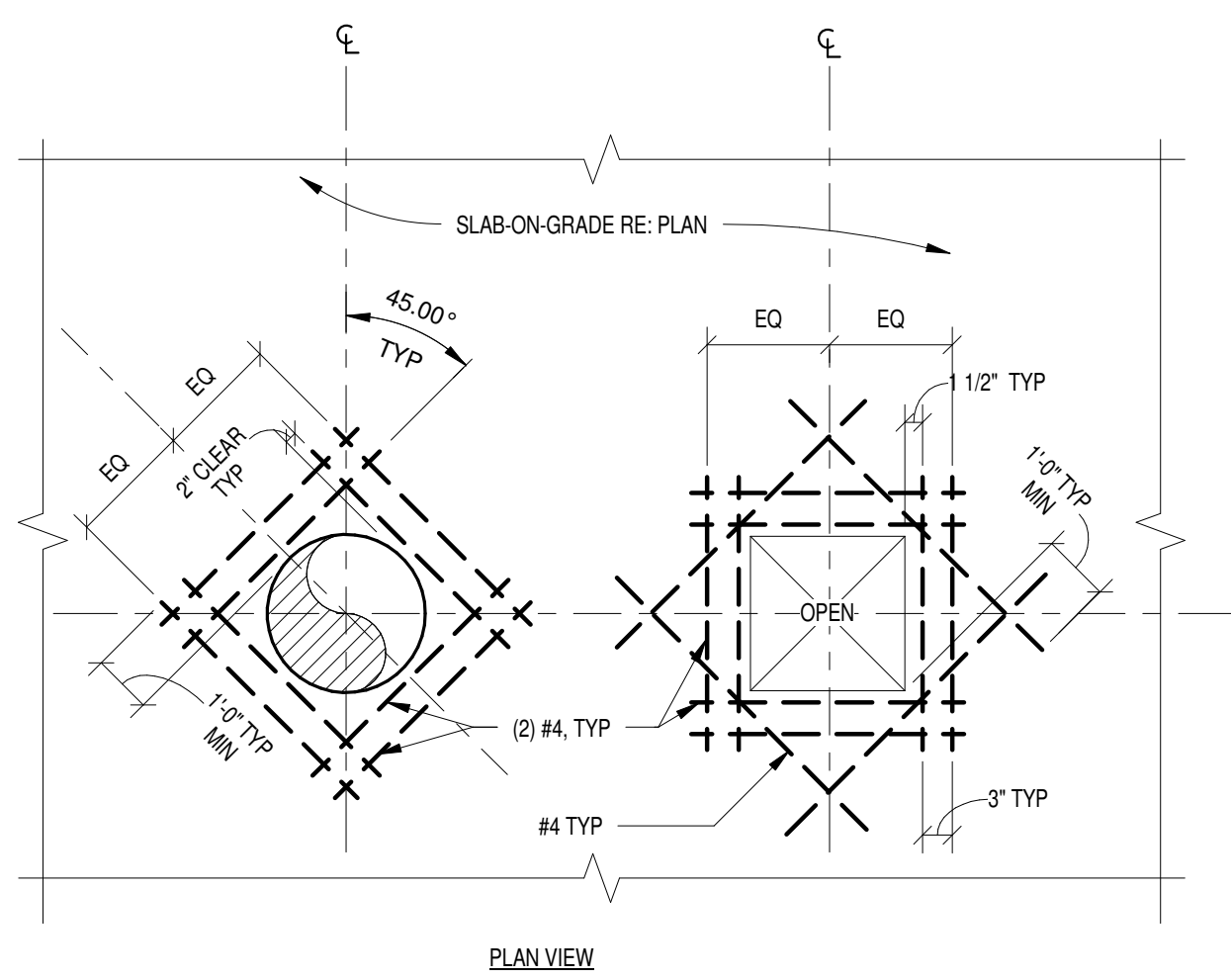

6 TYPICAL SLAB ADD'L REINF. AT OPENING
3/4" = 1'-0"

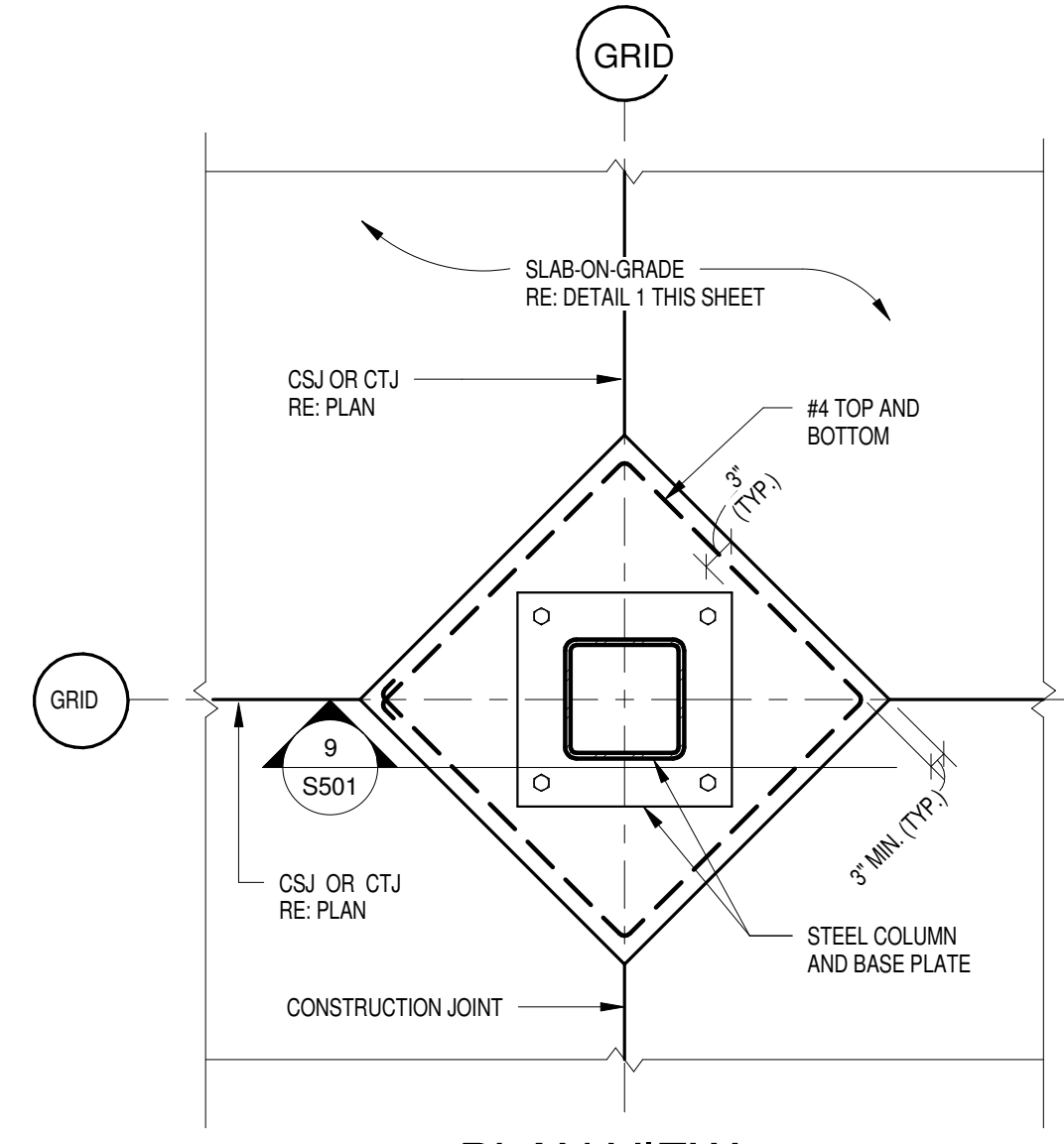

7 INTERIOR COLUMN BLOCKOUT
3/4" = 1'-0"

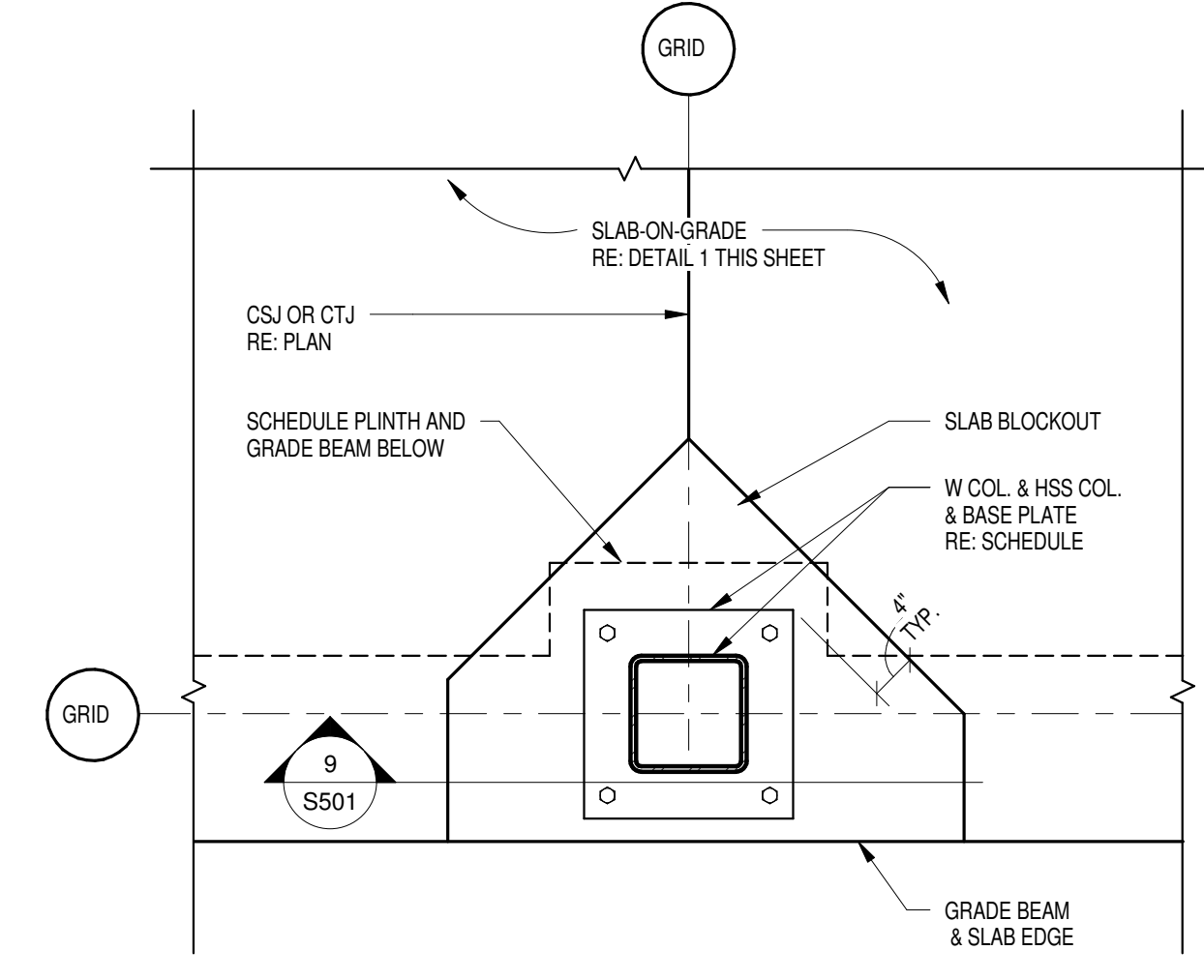

8 PERIMETER COLUMN BLOCKOUT
3/4" = 1'-0"

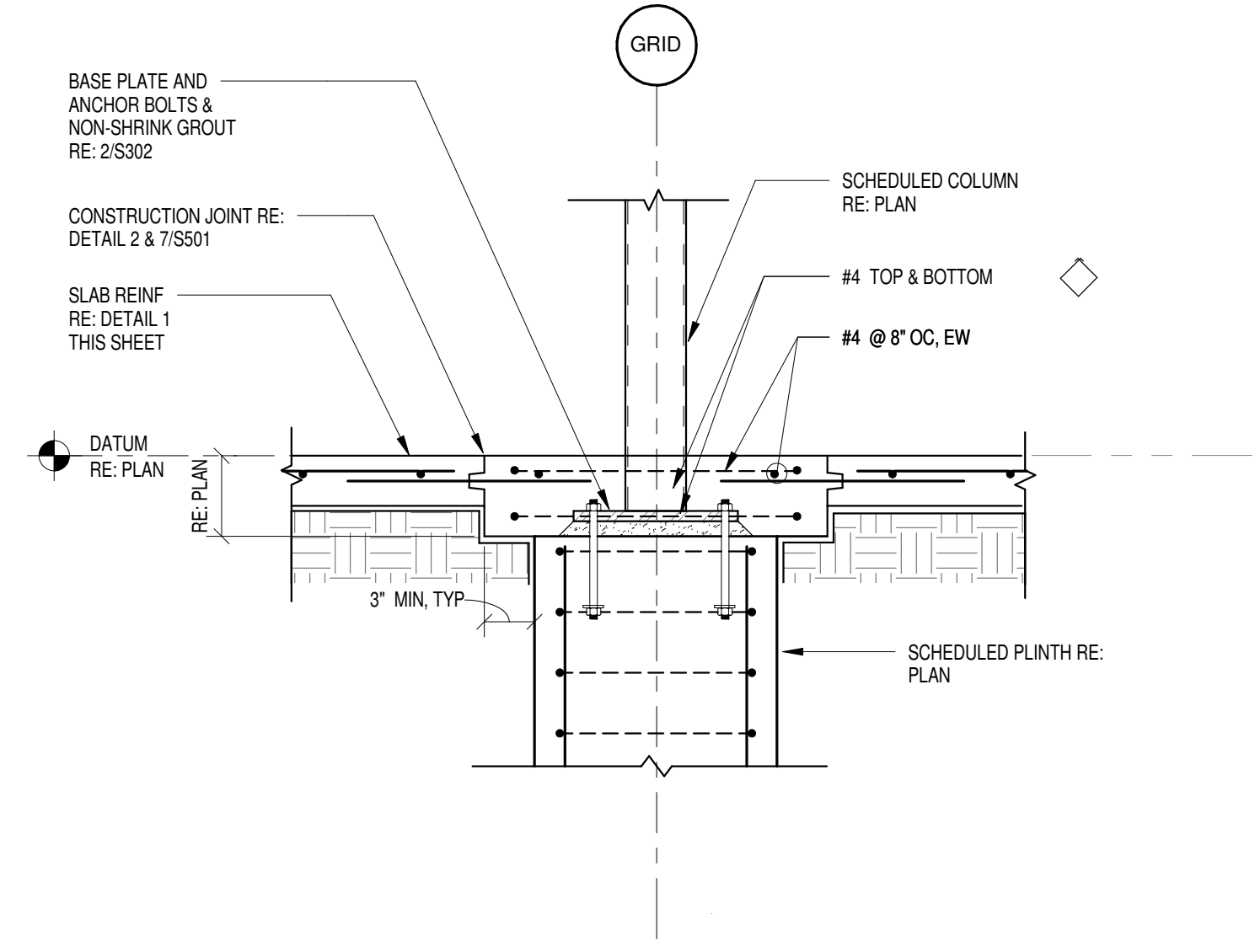

9 TYPICAL INTERIOR COLUMN SECTION
3/4" = 1'-0"

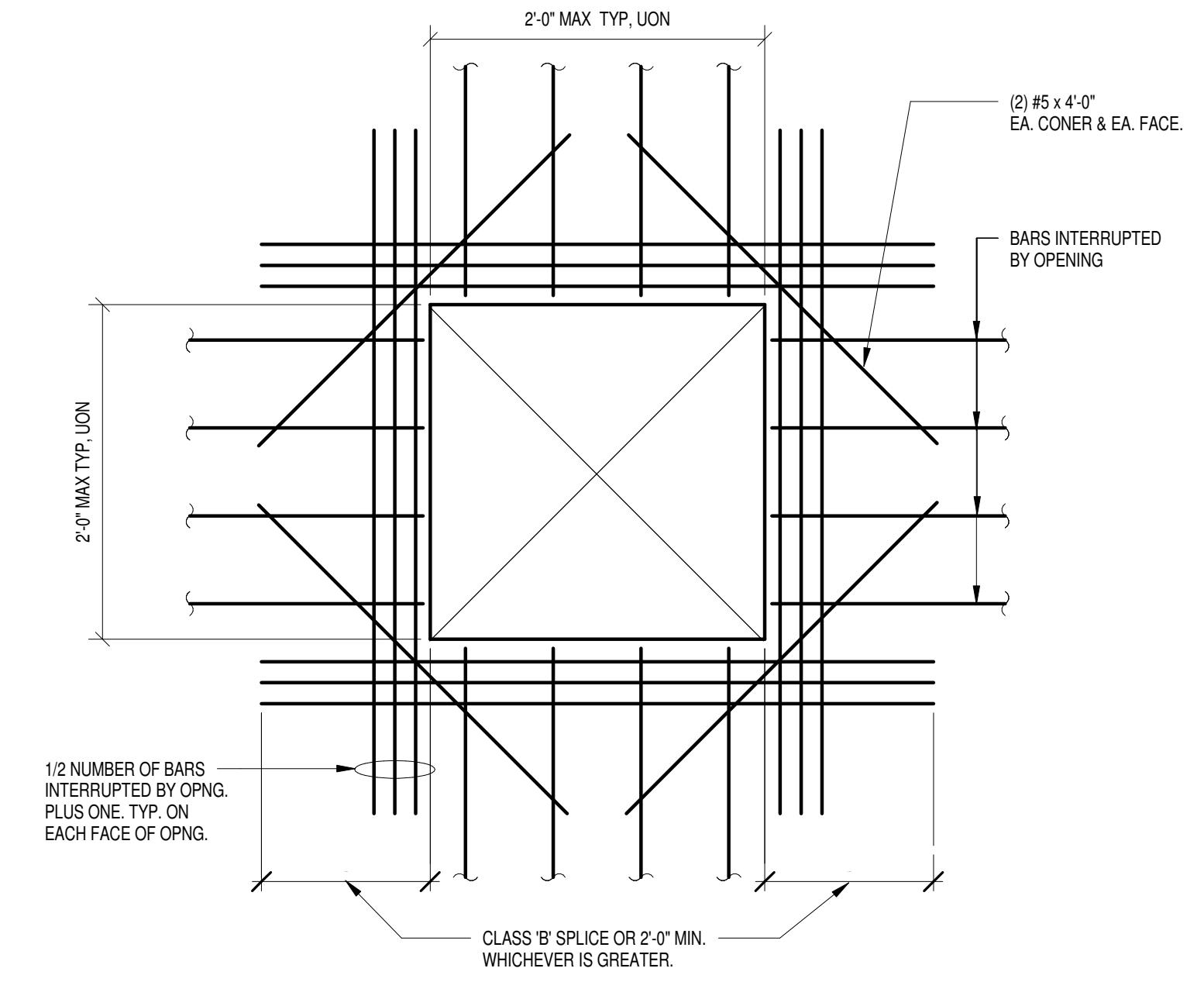

11 TYPICAL ADD'L BAR FOR WALL OR SLAB OPENING
3/4" = 1'-0"

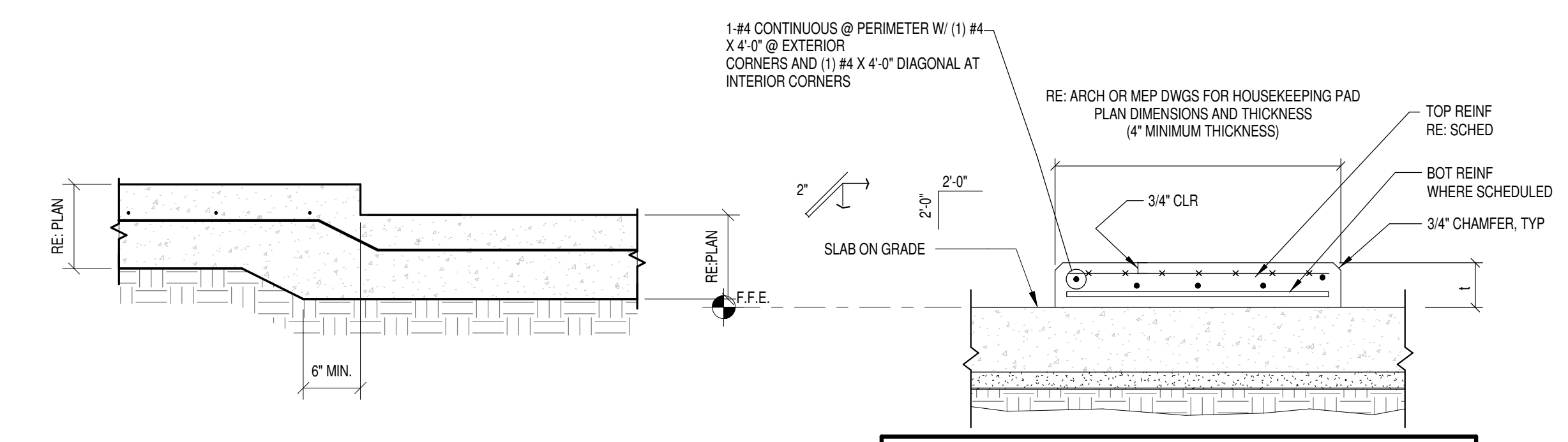

10 TYPICAL SLAB DEPRESSION DETAILS
3/4" = 1'-0"

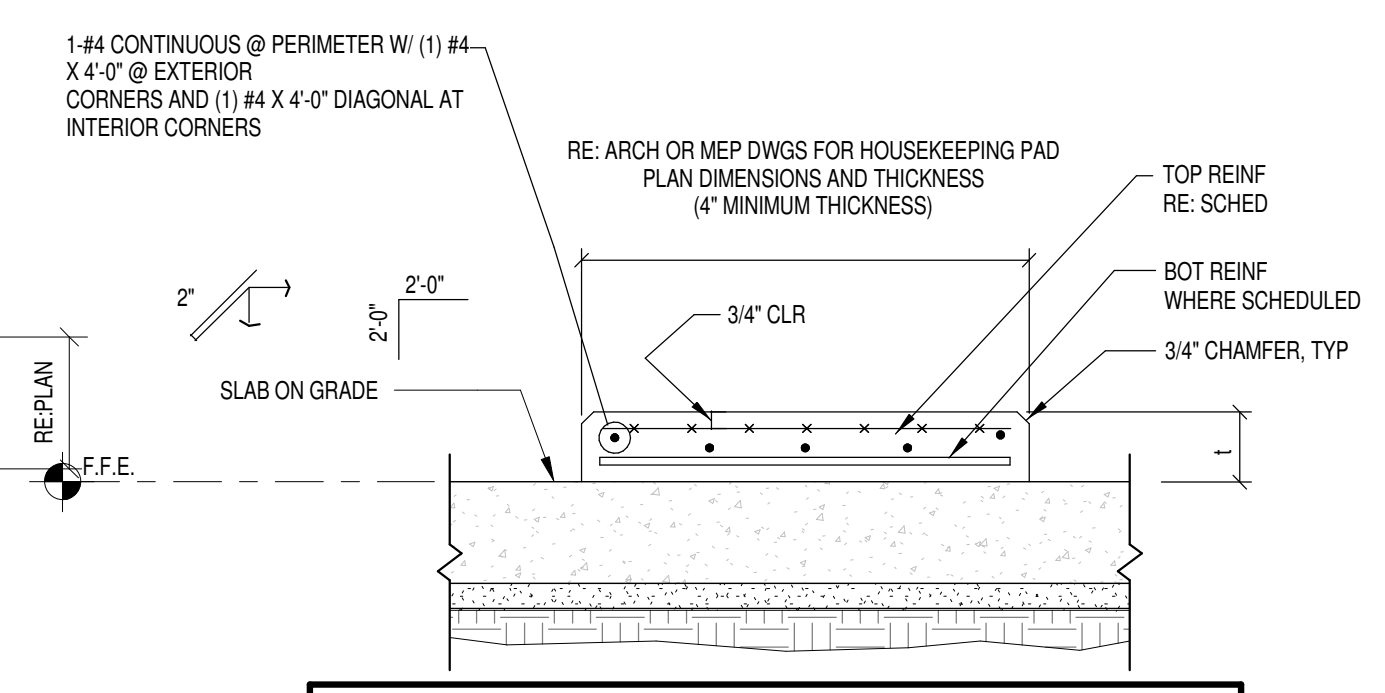

13 HOUSEKEEPING PAD
3/4" = 1'-0"

HOUSEKEEPING PAD REINFORCING SCHEDULE		
PAD THICKNESS	TOP REINFORCEMENT	BOTTOM REINF.
t <= 4"	6' x 6' W2.9 x W2.9	NONE
4' < t <= 6"	4' x 4' W4.0 x W4.0	NONE
6' < t <= 8"	4' x 4' W5.5 x W5.5	NONE
8' < t <= 12"	#4@12'EW	#3@18'EW
12' < t <= 16"	#4@12'EW	#4@12'EW

NOTES:
1. GENERAL CONTRACTOR TO COORDINATE WITH MECHANICAL DRAWINGS AND SPECIFICATIONS TO DETERMINE REQUIREMENTS FOR HOUSEKEEPING PADS OVER SLAB ON GRADE AND PROVIDE WHERE REQUIRED WHETHER SHOWN ON STRUCTURAL DRAWINGS OR NOT. COORDINATE DIMENSIONS AND OTHER SPECIAL REQUIREMENTS WITH EQUIPMENT MANUFACTURERS AS REQUIRED.



Boucher Design Group LLC
Members A.I.A.
6802 Mapleridge, Suite 200
Bellaire, Texas 77401
Tel. 713.785.3644
www.bdgap.com

This document is an instrument of service protected by the copyright law of the United States of America, 17 U.S.C §102, and shall not be copied or reproduced without the express written consent of Boucher Design Group, LLC. 2015

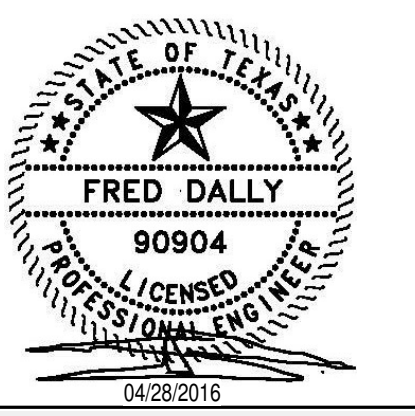

BAYSIDE COMMUNITY CENTER
BACLIFF, TEXAS
GALVESTON COUNTY

DATE	02/29/16
PROJECT NO.	1409000
DRAWN BY	RW
CHECKED BY	FD

TYPICAL FOUNDATION DETAILS

S501

© COPYRIGHT 2016 BOUCHER DESIGN GROUP, LLC

ISSUE #	DATE	DESCRIPTION
1	03-23-2016	ADDENDUM 3

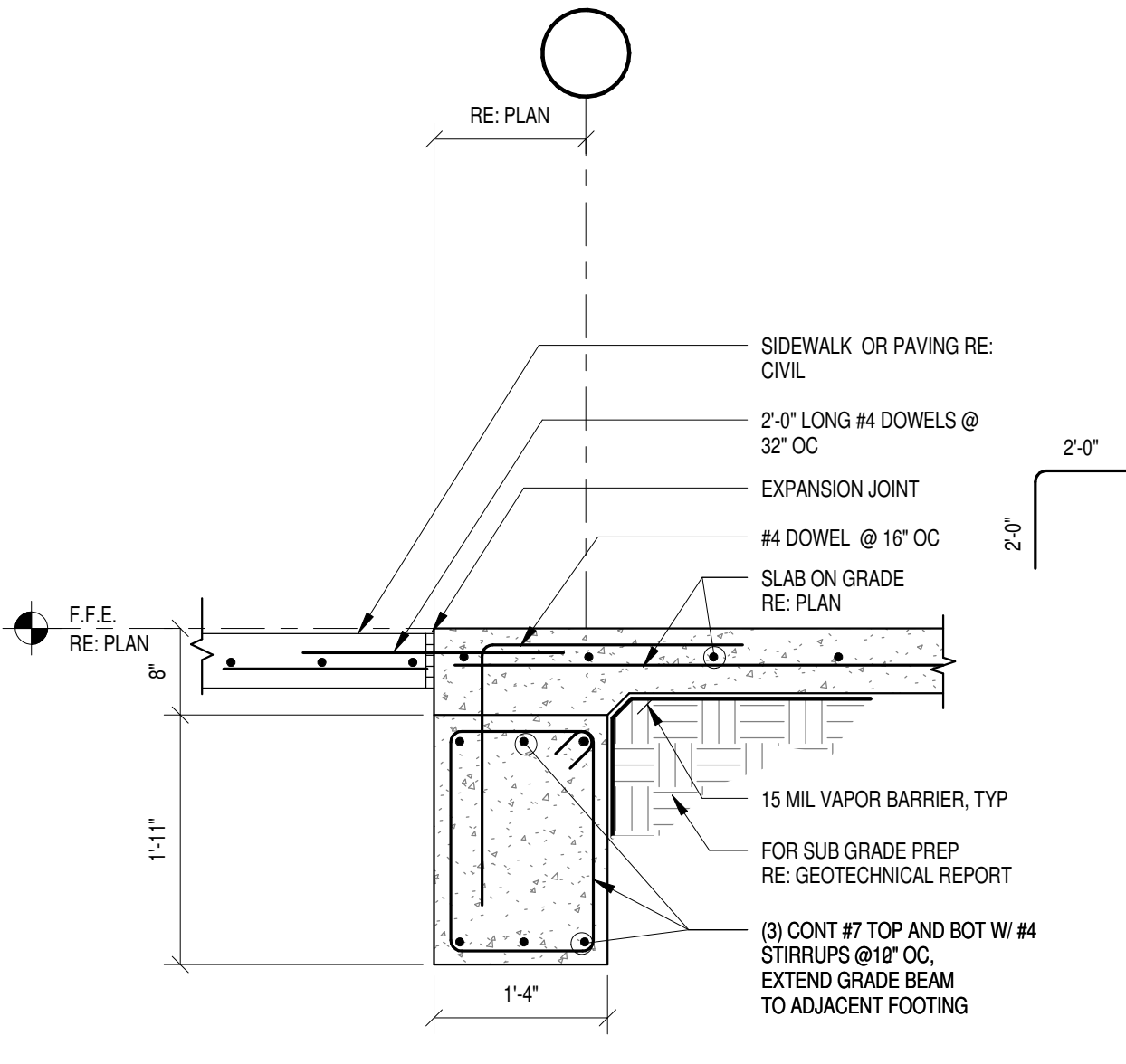

1 TYPICAL GRADE BEAM DETAIL
3/4" = 1'-0"

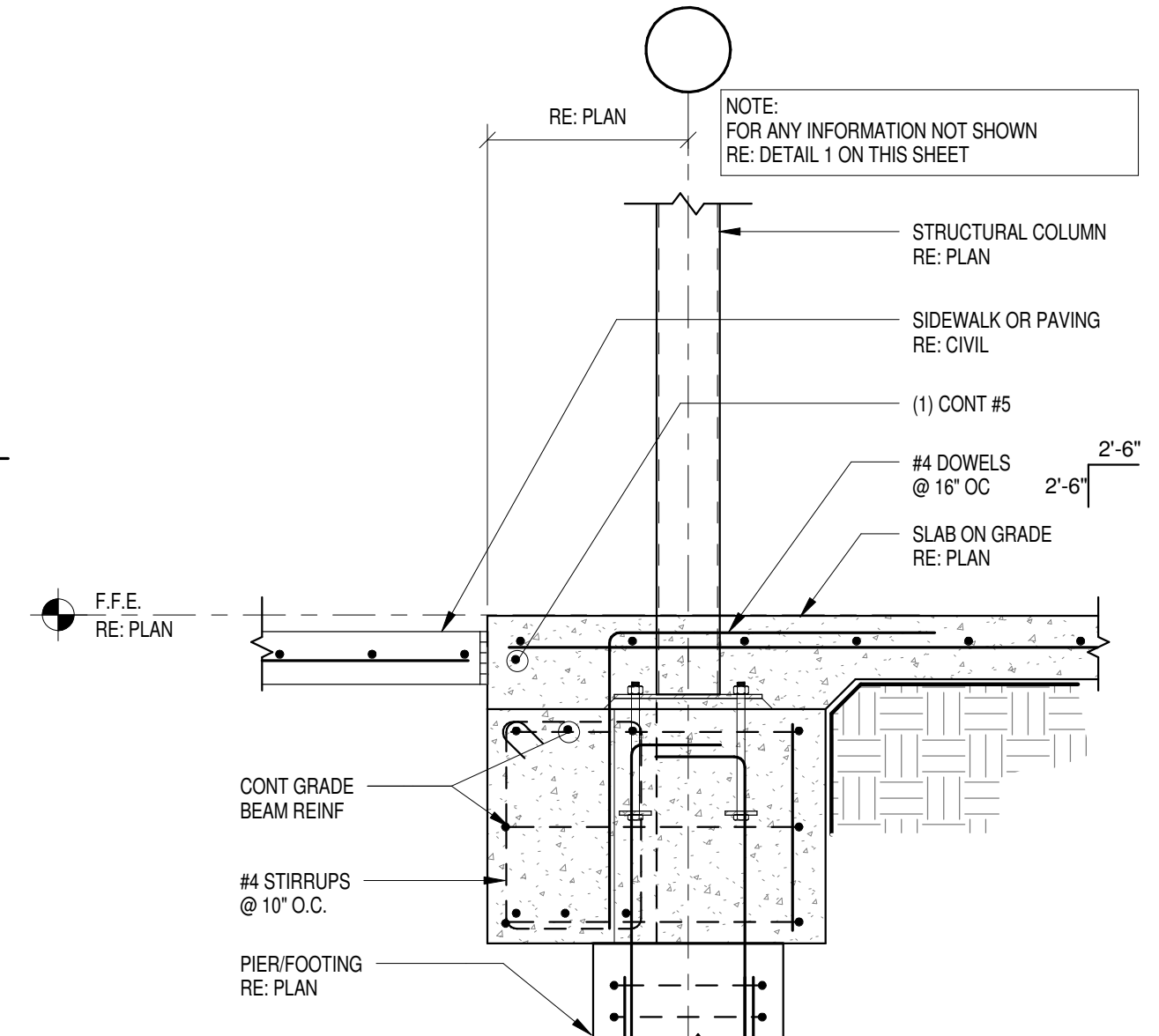

2 EXTERIOR COLUMN WITH PLINTH SECTION
3/4" = 1'-0"

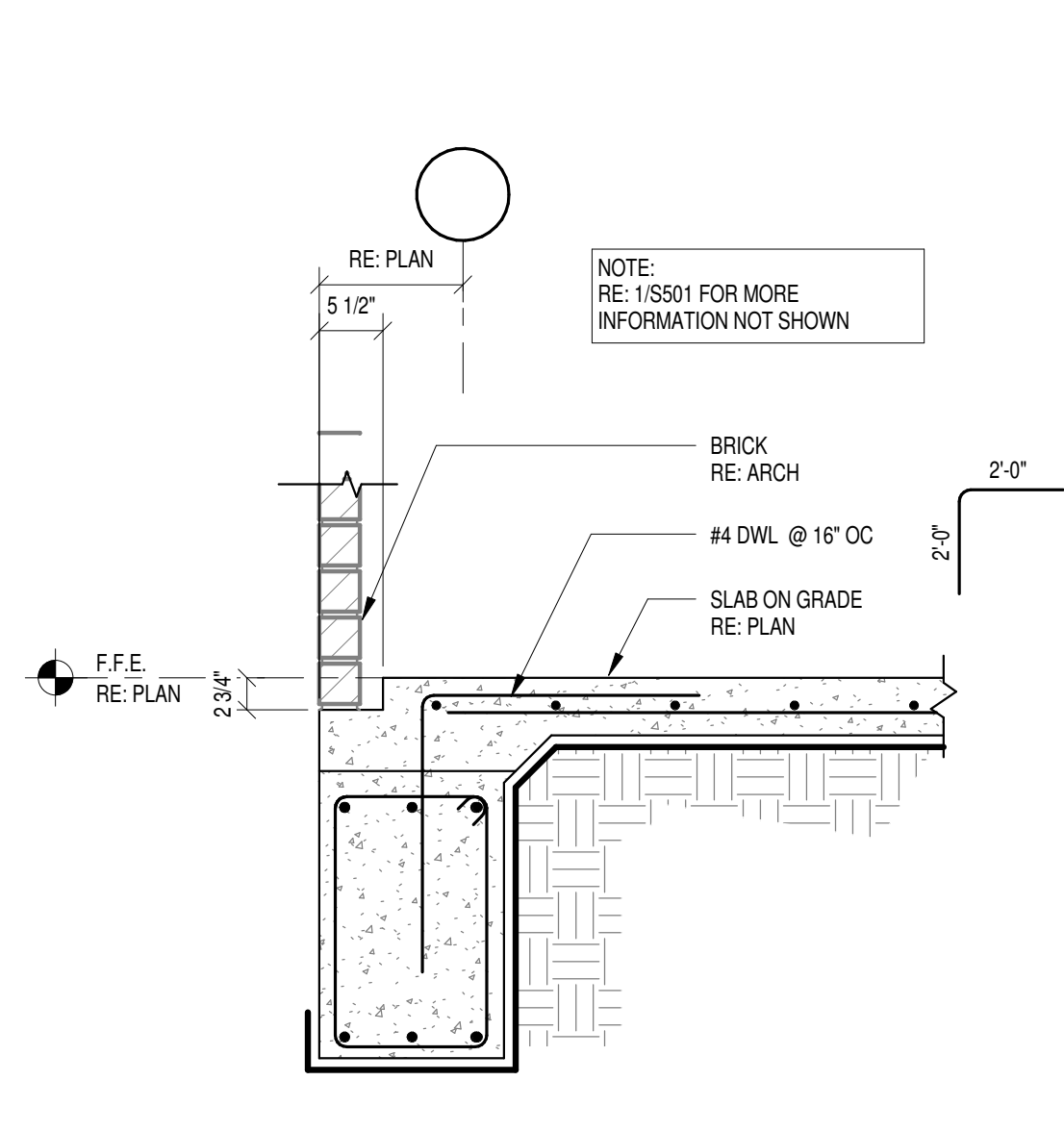

3 EXTERIOR SECTION
3/4" = 1'-0"

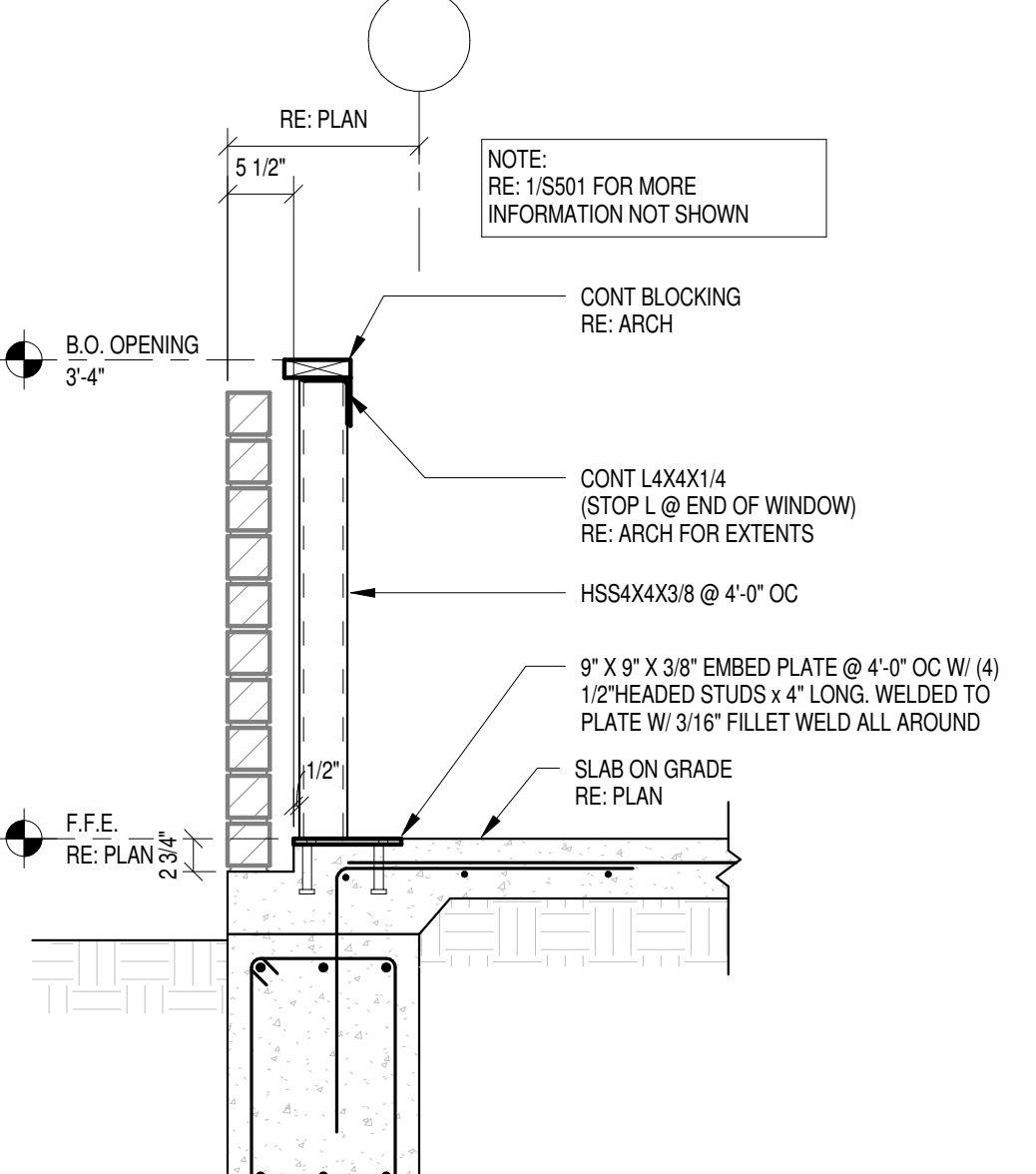

4 SECTION
3/4" = 1'-0"

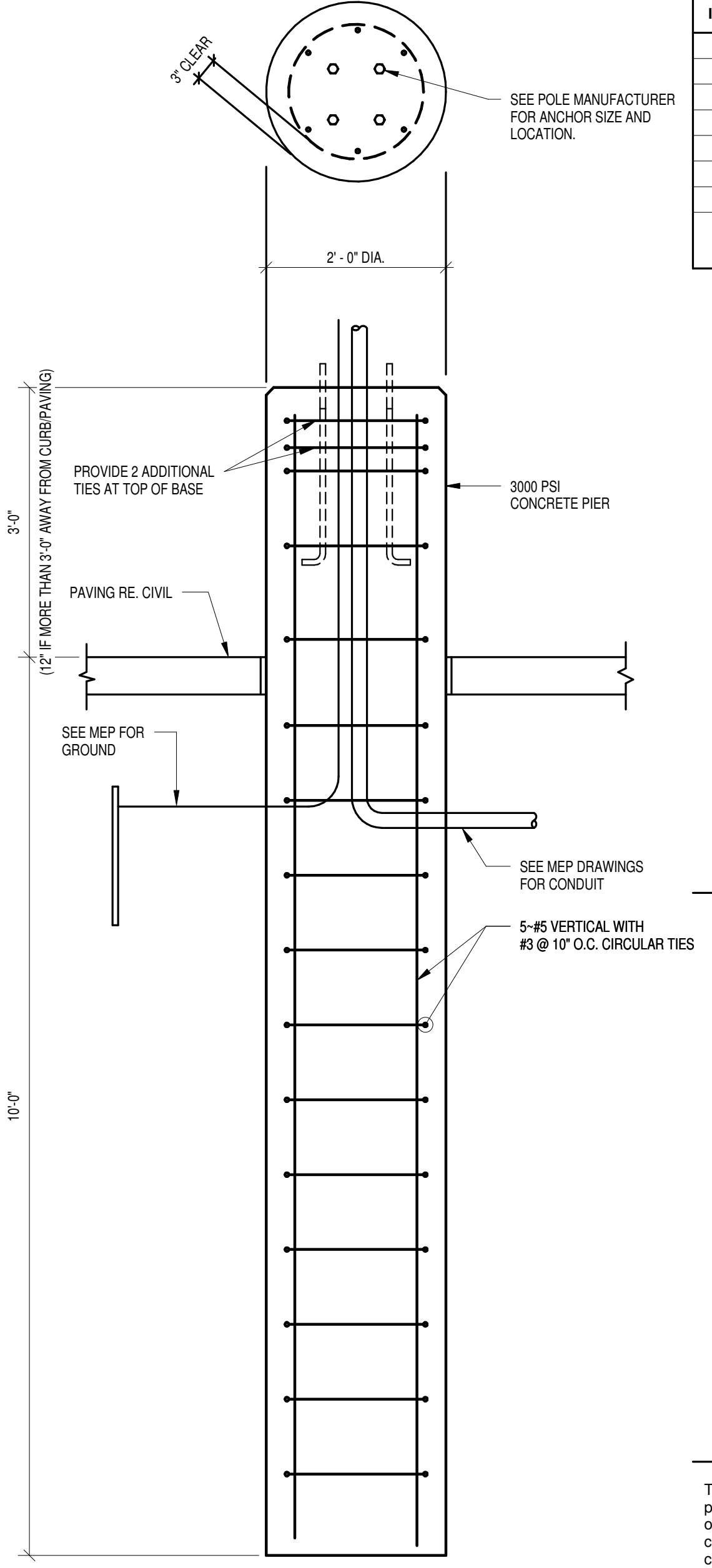

5 TYPICAL LIGHT POLE DETAIL
3/4" = 1'-0"

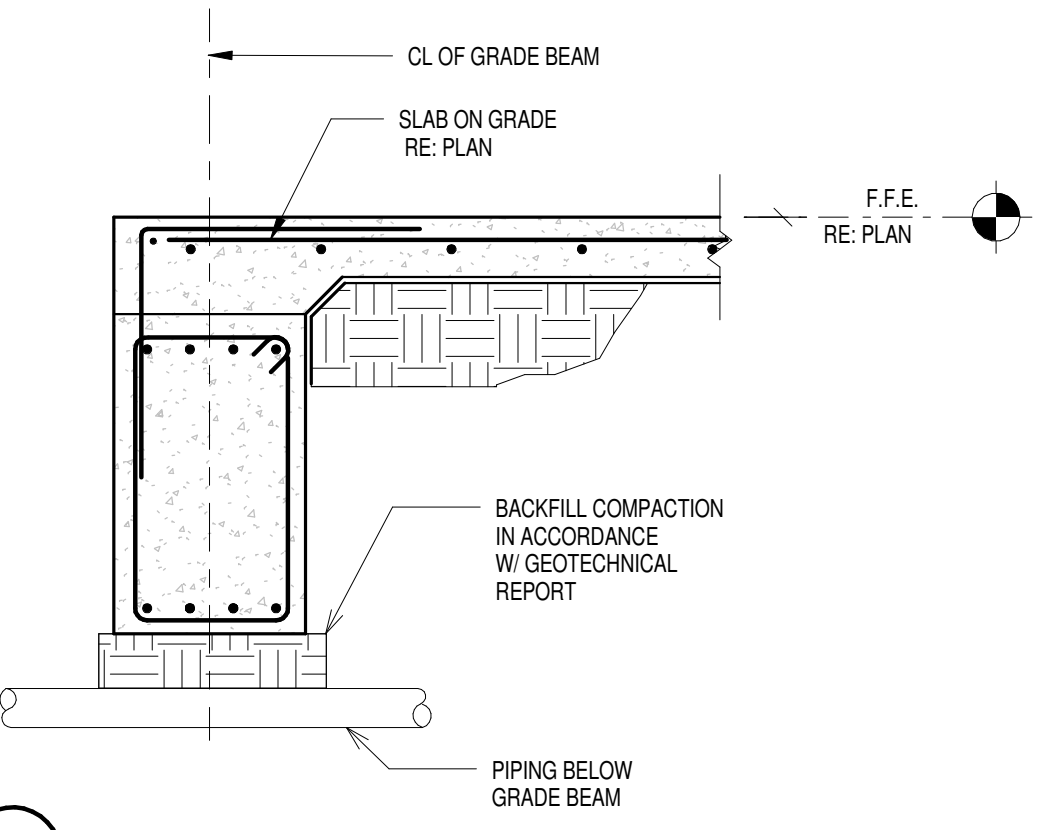

A CONDUIT BELOW GRADE BEAM
6 TYP. CONDITION OF CONDUIT
3/4" = 1'-0"

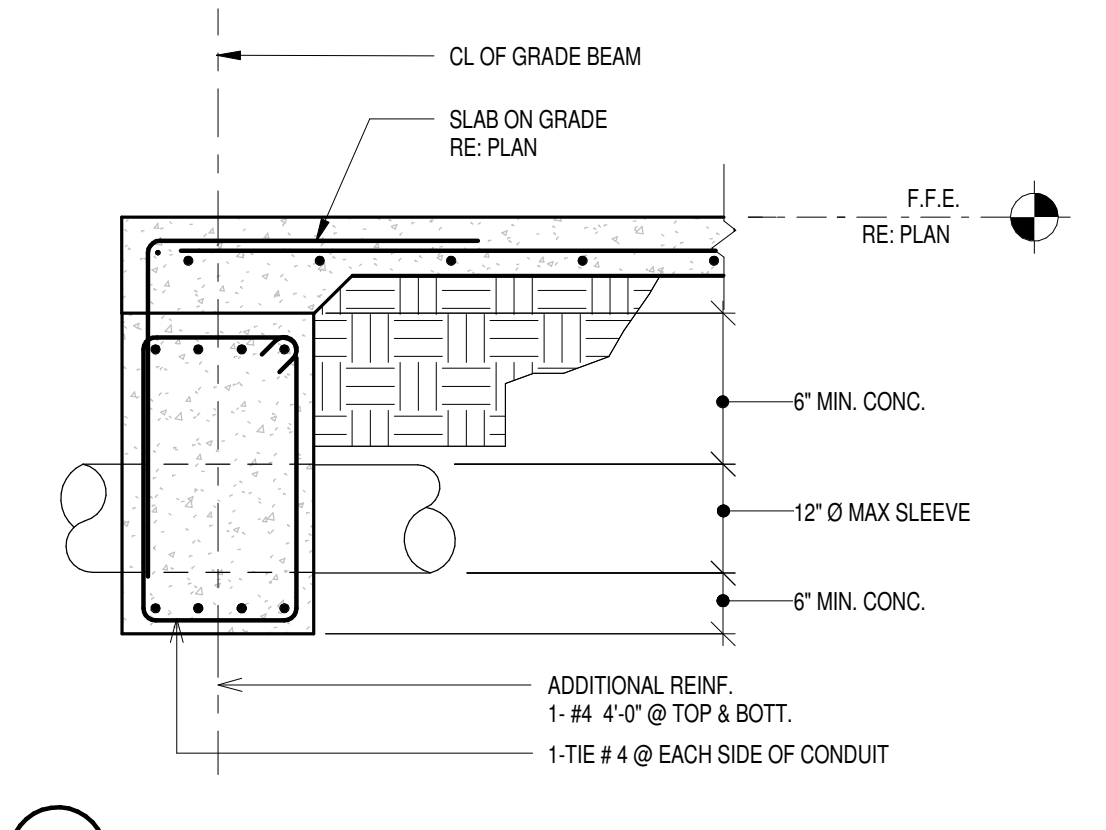

B CONDUIT THRU GRADE BEAM

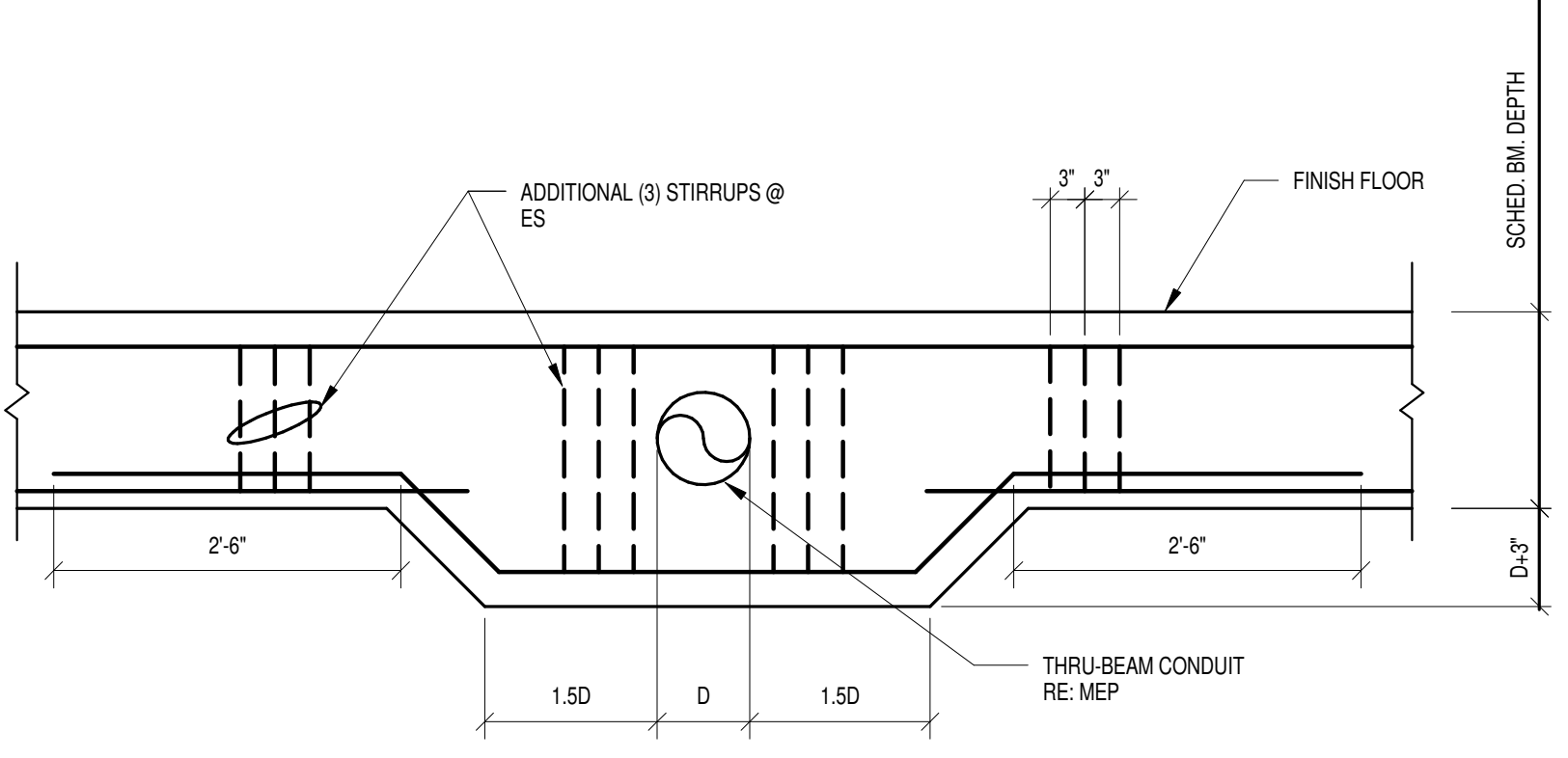

7 TYPICAL THRU-BEAM CONDUIT
3/4" = 1'-0"

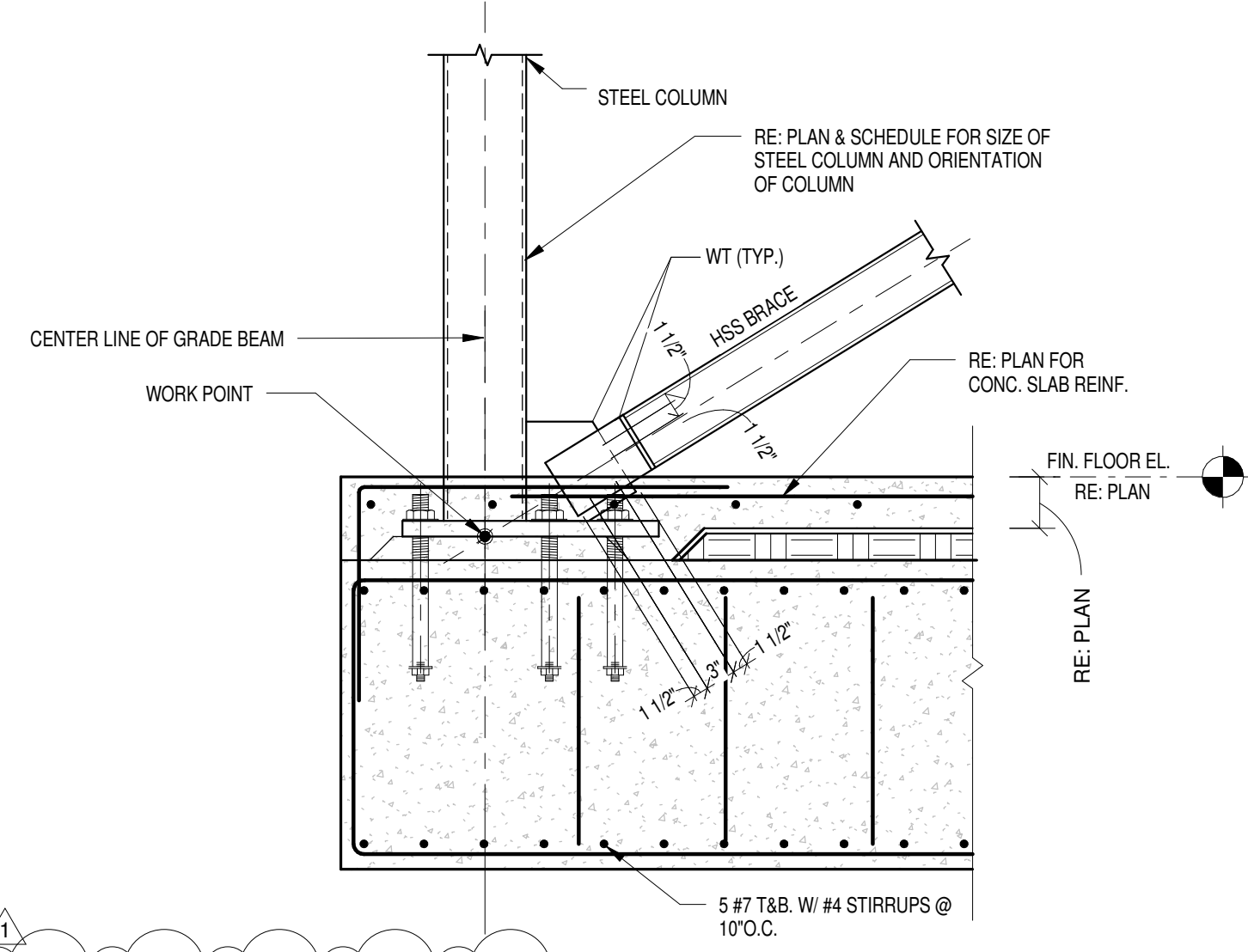

8 TYPICAL INTERIOR GRADE BEAM AT WIND BRACING
3/4" = 1'-0"

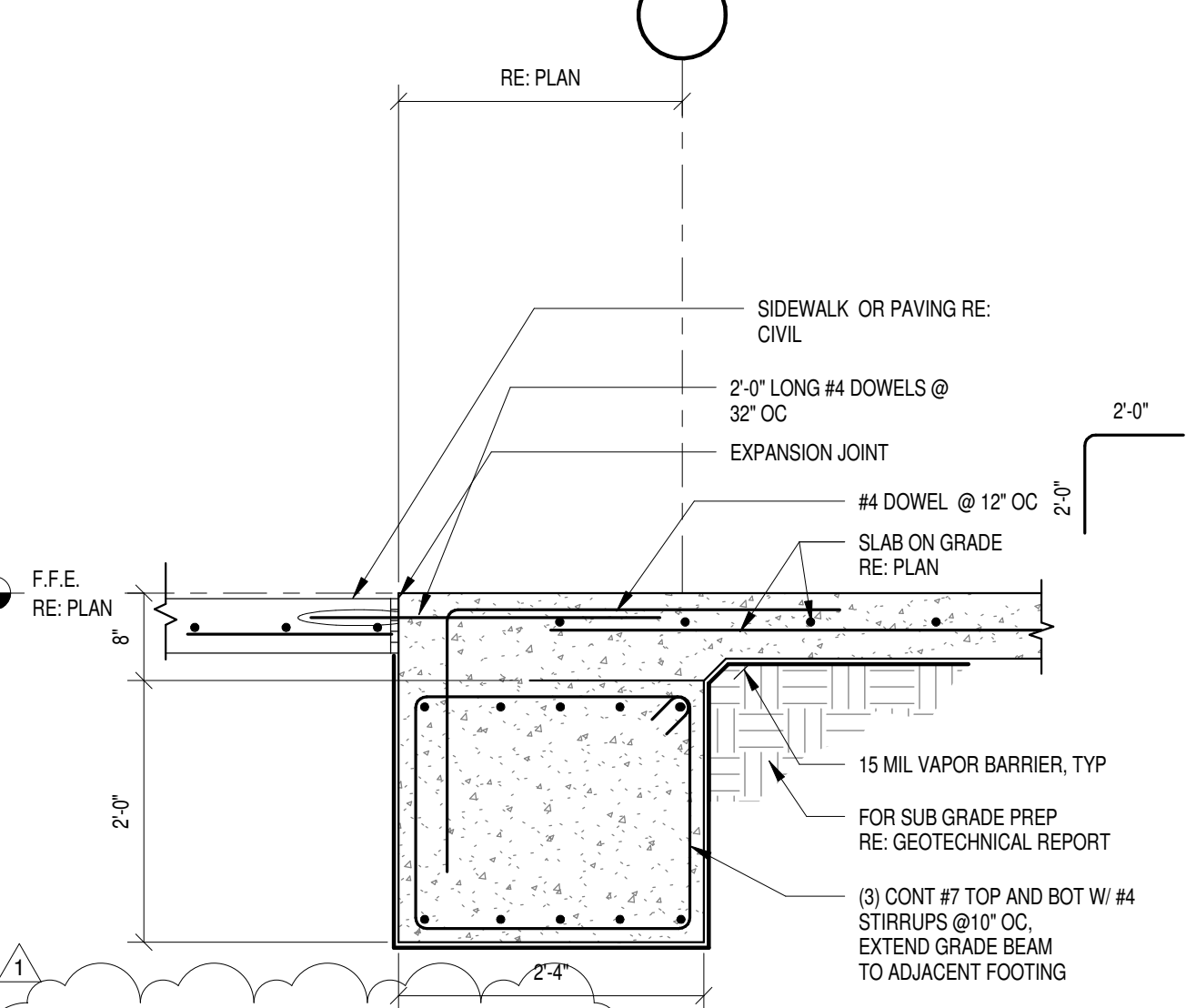
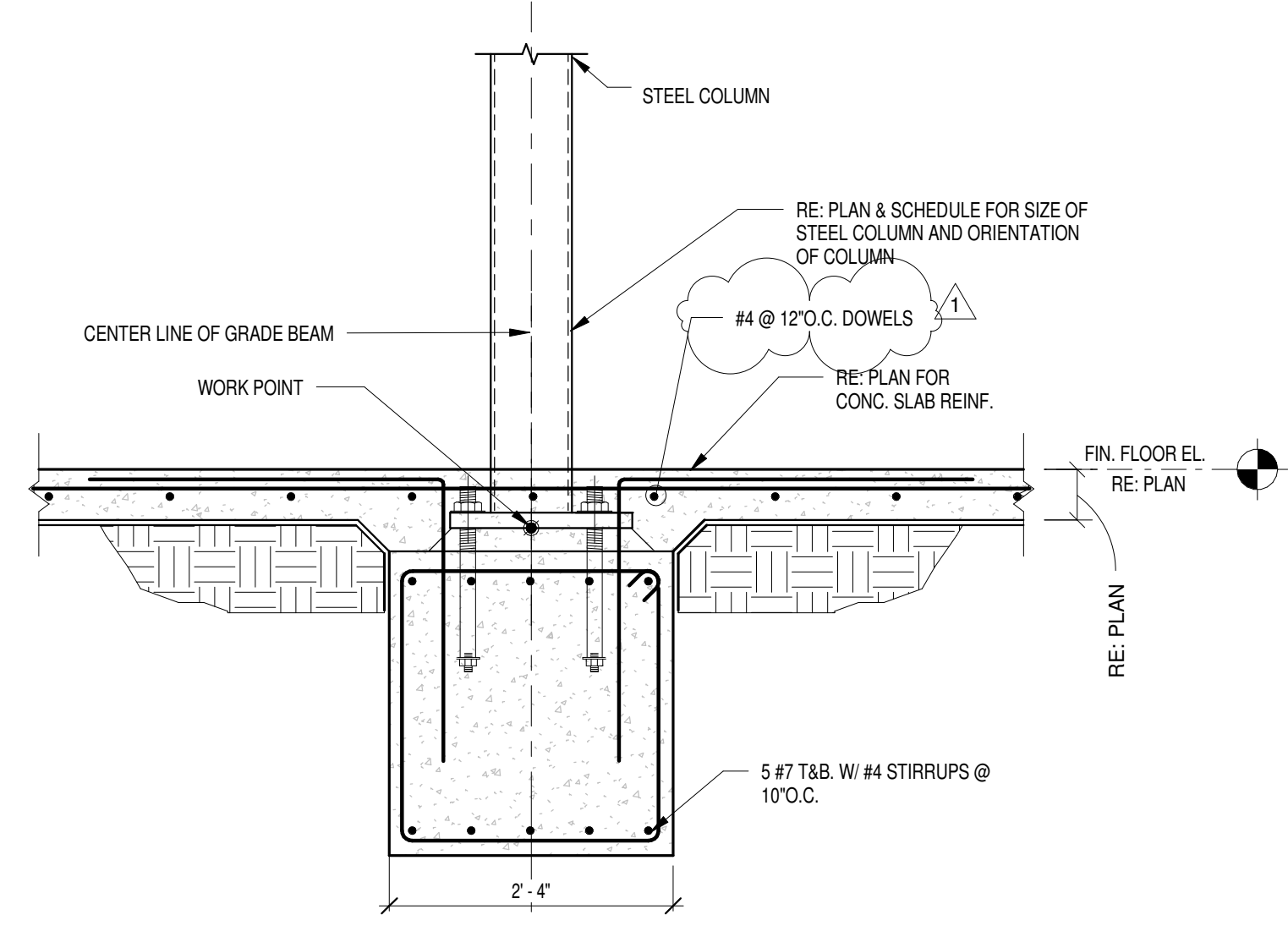

9 TYPICAL EXTERIOR GRADE BEAM DETAIL @ WIND BRACING
3/4" = 1'-0"

bdg
architecture
+ planning
boucher design group

Boucher Design Group LLC
Members A.I.A.
6802 Mapleridge, Suite 200
Bellaire, Texas 77401
Tel. 713.785.3644
www.bdgap.com

This document is an instrument of service protected by the copyright law of the United States of America, 17 U.S.C. §102, and shall not be copied or reproduced without the express written consent of Boucher Design Group, LLC. 2015



BAYSIDE COMMUNITY CENTER
BACLIFF, TEXAS

GALVESTON COUNTY

DATE	02/29/16
PROJECT NO.	1409000
DRAWN BY	RW
CHECKED BY	FD

FOUNDATION DETAILS

C:\Users\juser\Desktop\Local Files\2015\15-124-00 Bayshore Community Center_TCK.vrt 5/17/2016 8:09:31 AM

ISSUE #	DATE	DESCRIPTION
1	03-23-2016	ADDENDUM 3

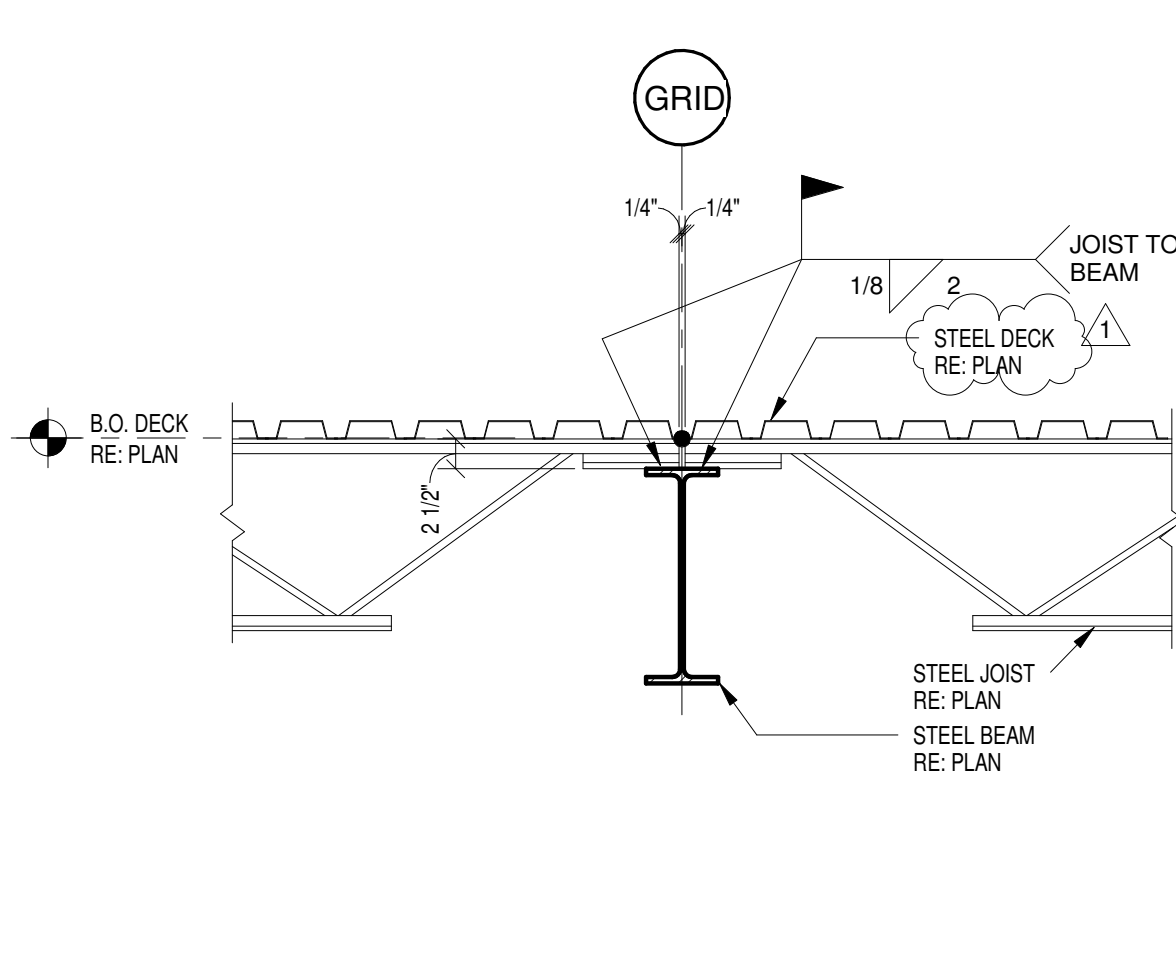

1 TYPICAL ROOF SECTION
3/4" = 1'-0"

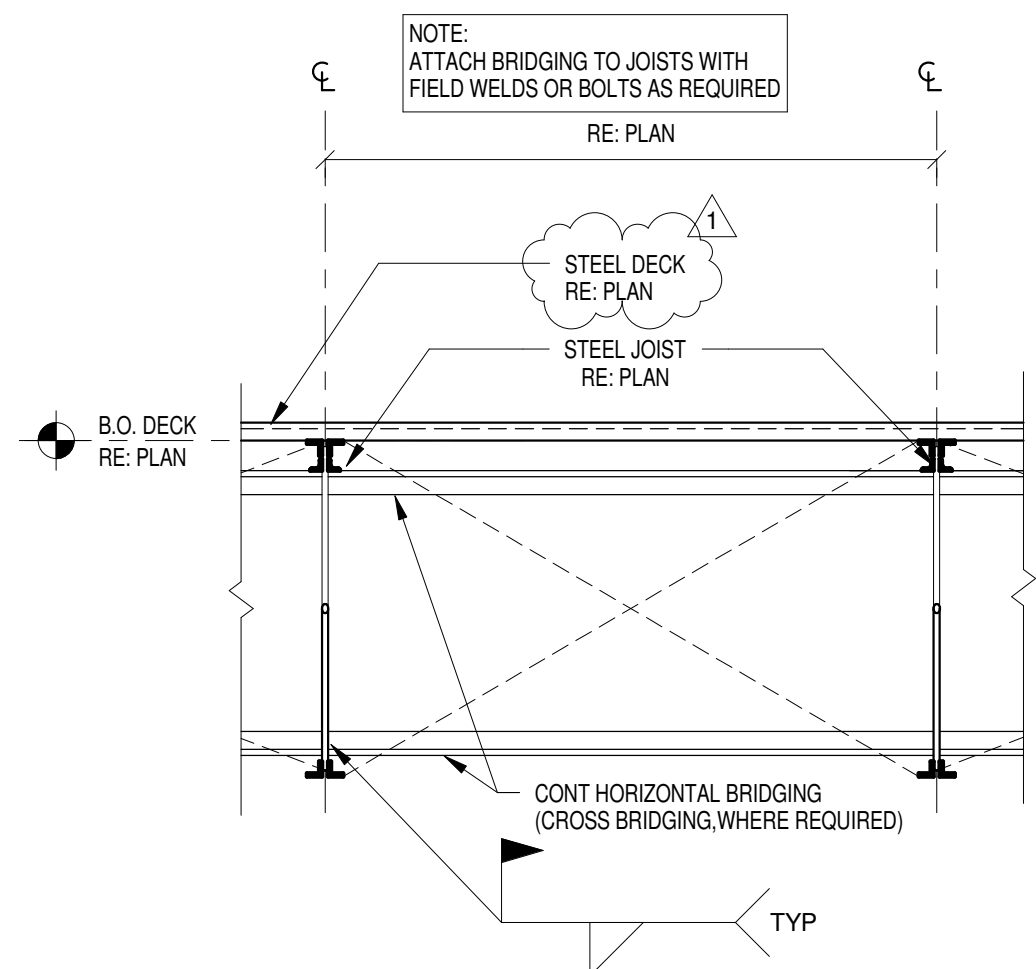

2 TYPICAL ROOF SECTION
3/4" = 1'-0"

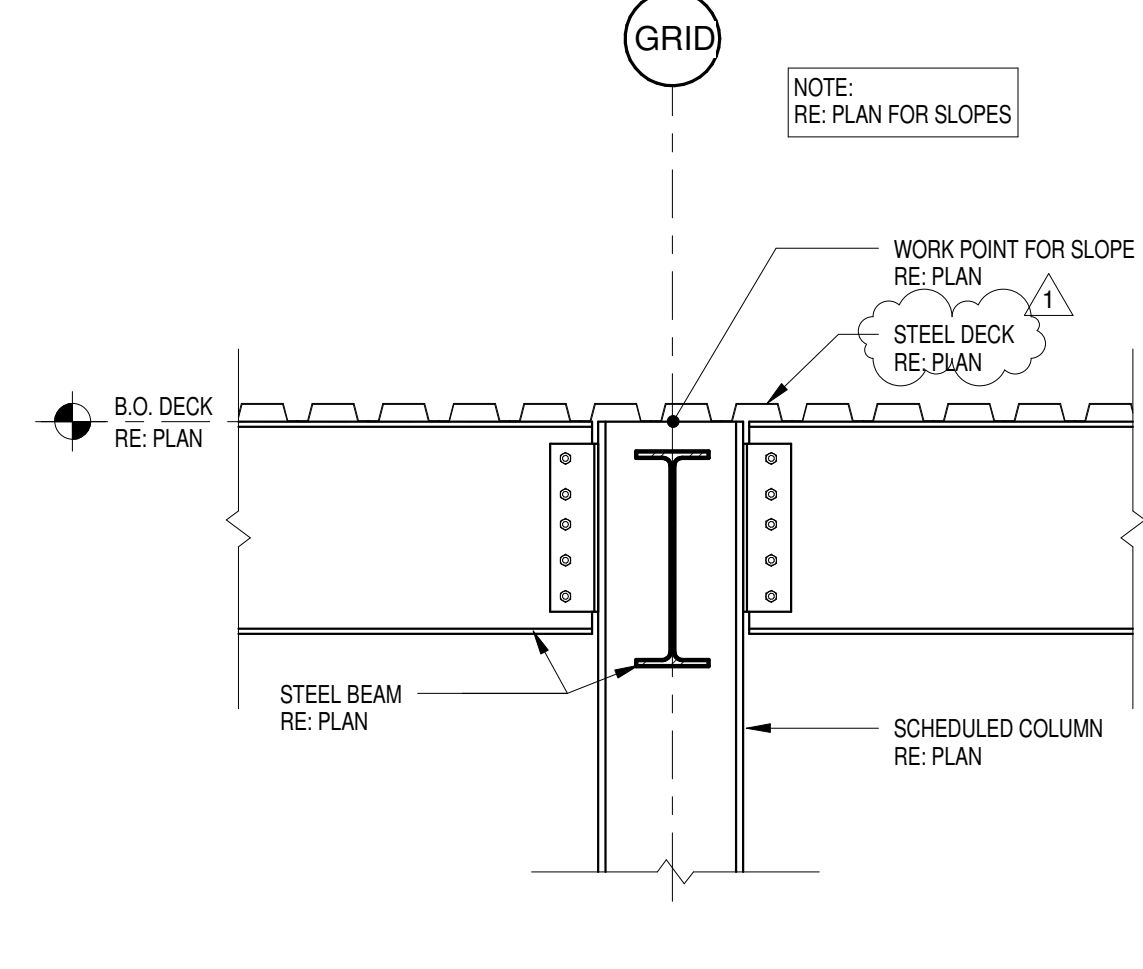

3 TYPICAL ROOF SECTION
3/4" = 1'-0"

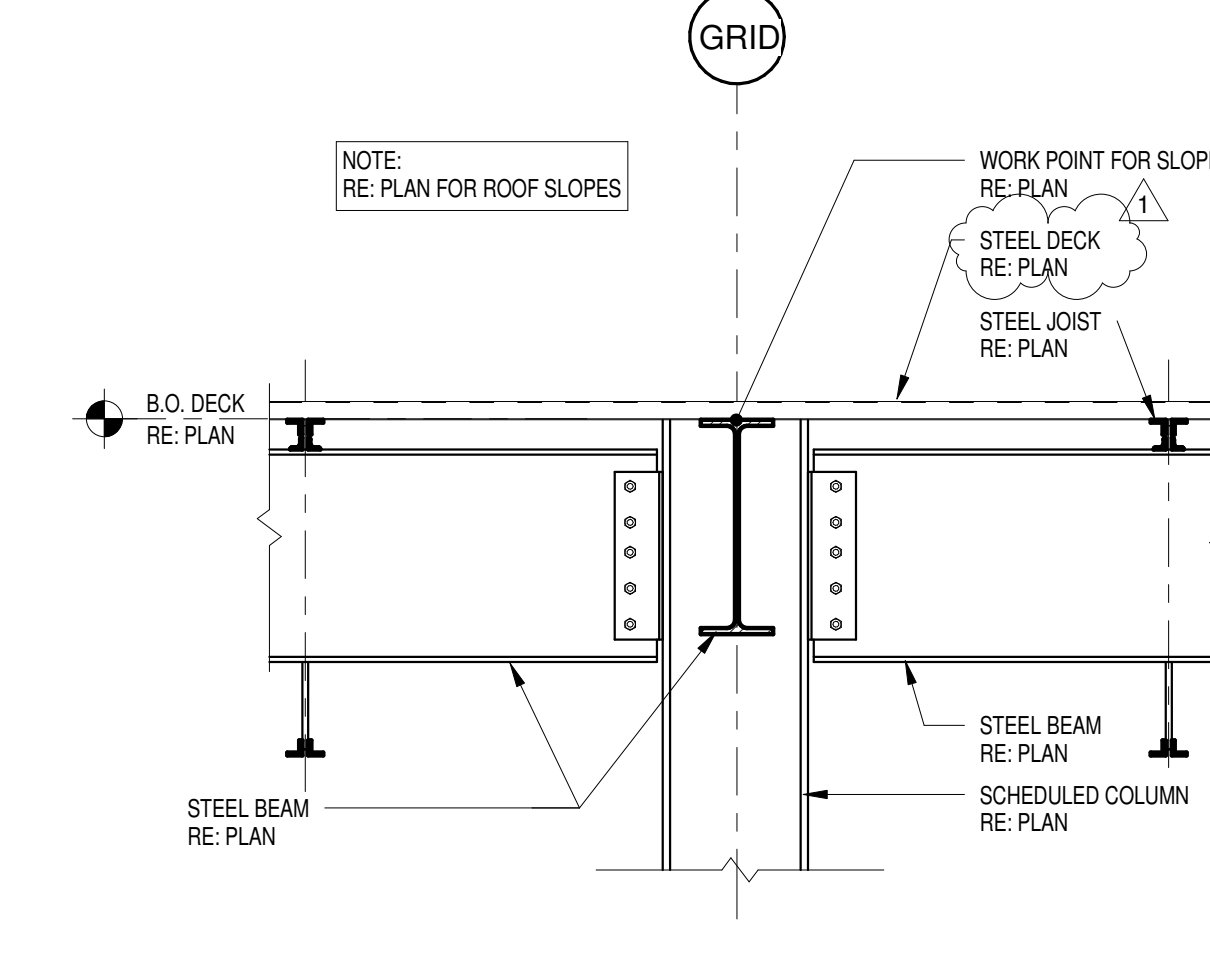

4 TYPICAL ROOF SECTION
3/4" = 1'-0"

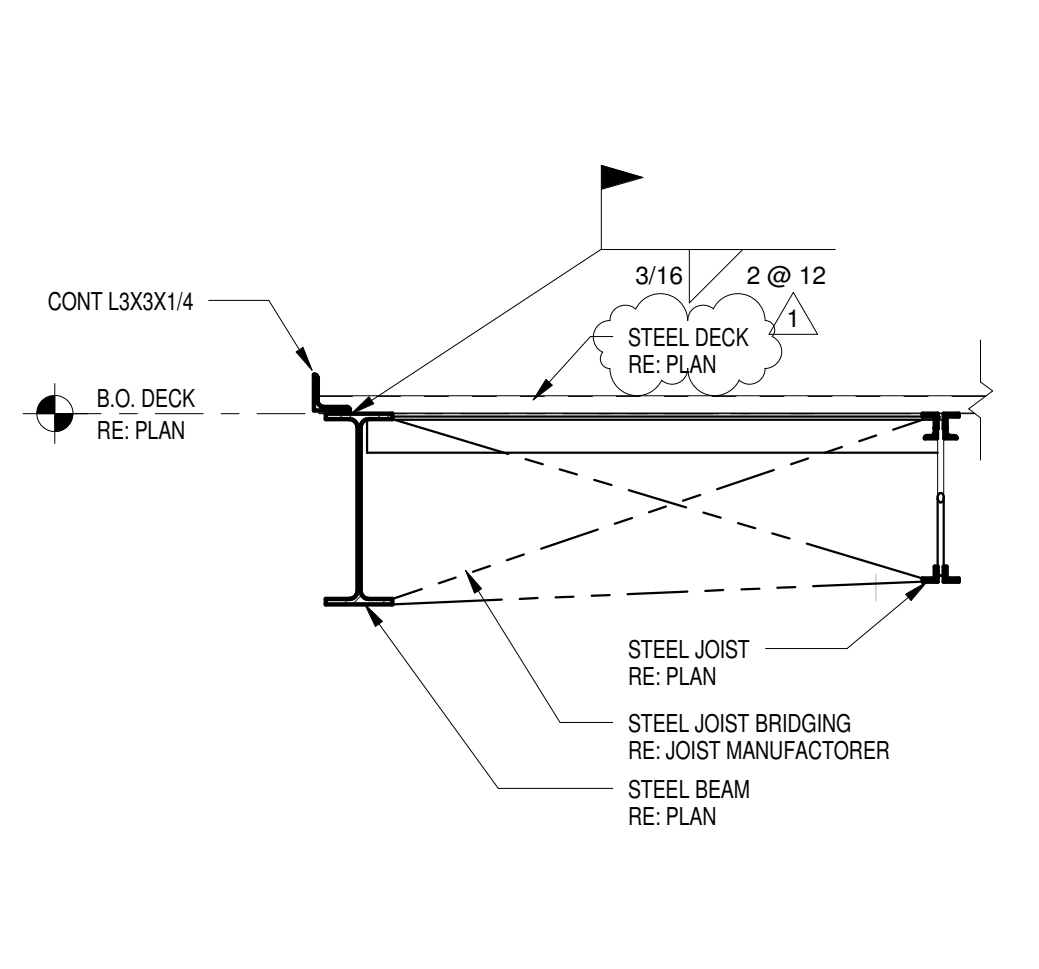

5 ROOF SECTION
3/4" = 1'-0"

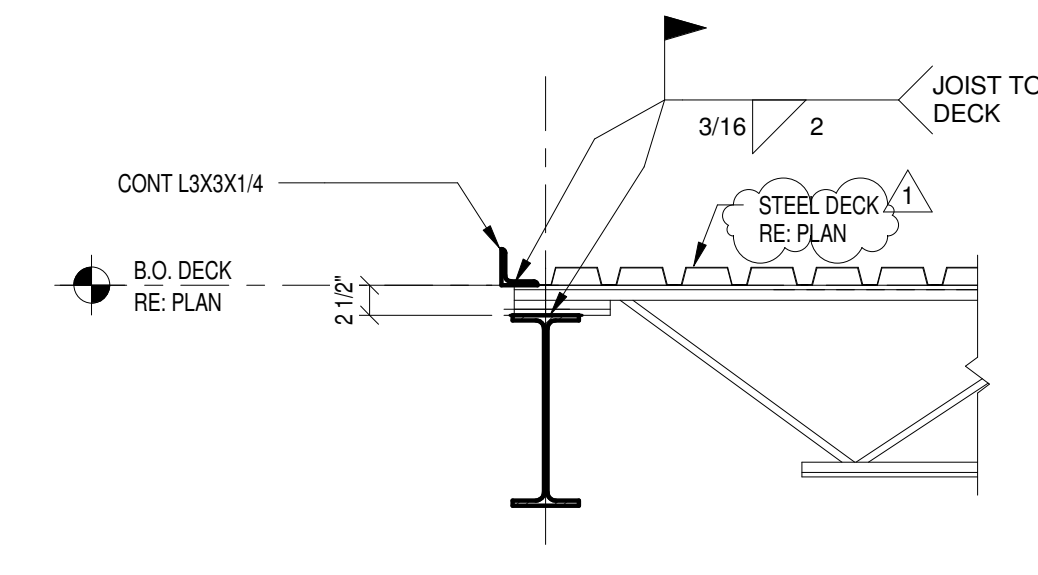

6 ROOF SECTION
3/4" = 1'-0"

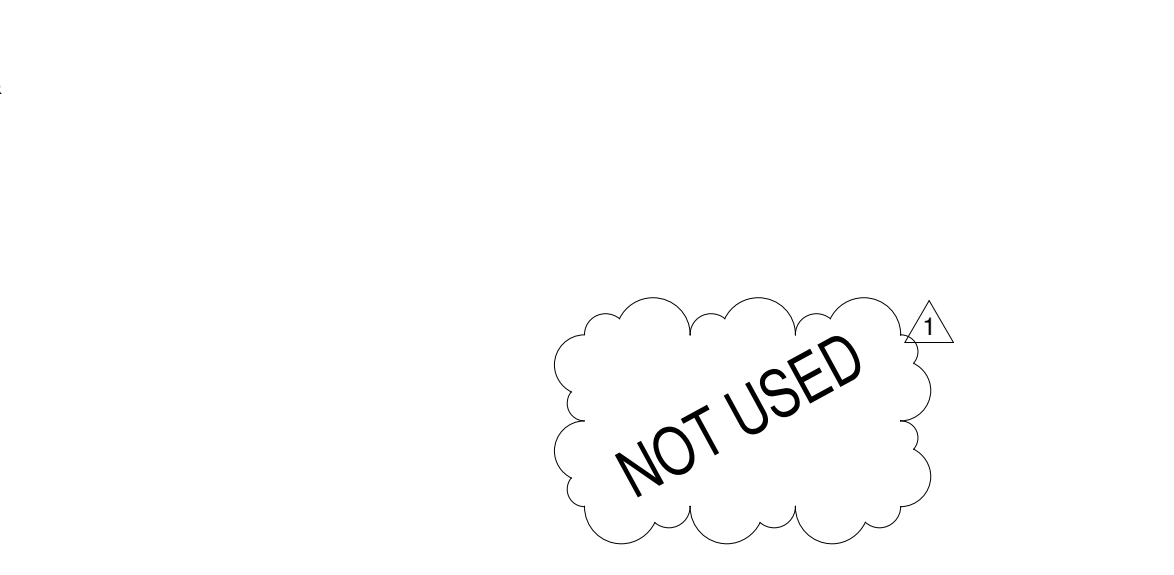

7 SECTION
3/4" = 1'-0"

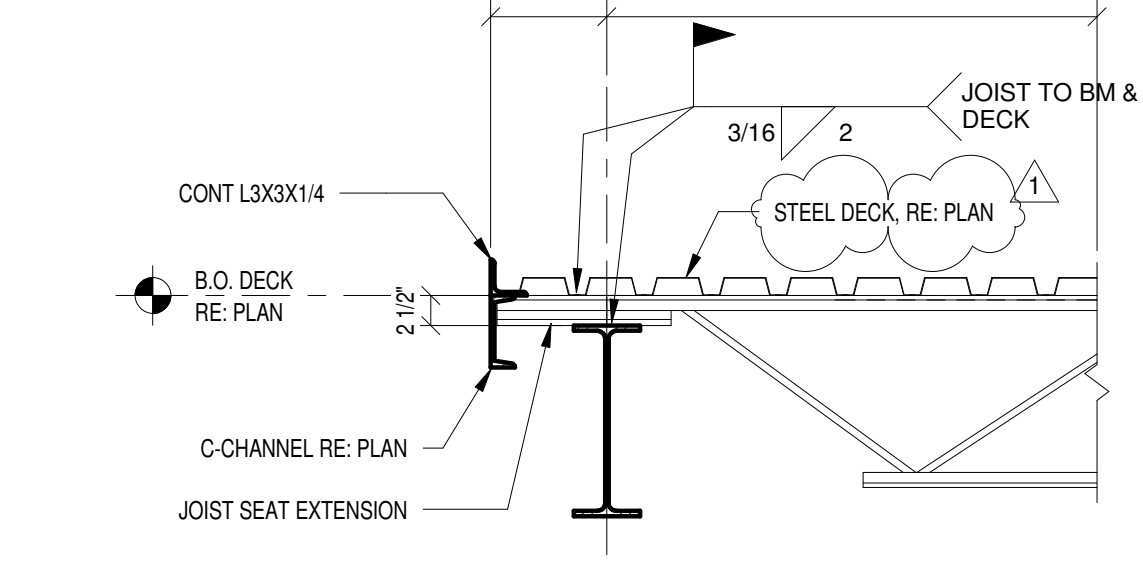

8 SECTION
3/4" = 1'-0"

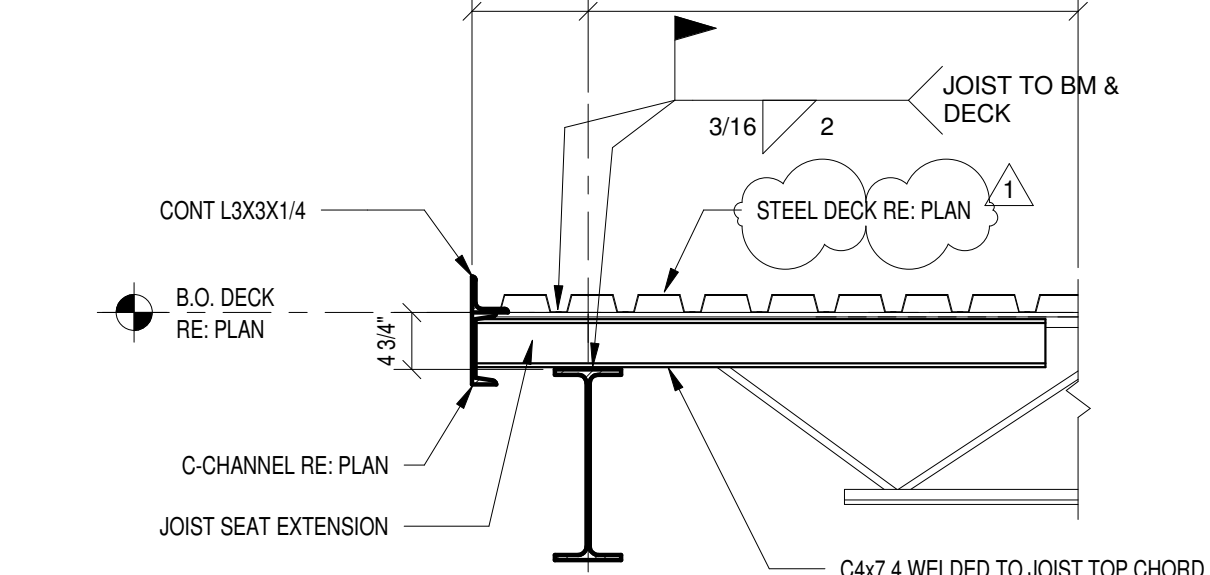

9 SECTION
3/4" = 1'-0"

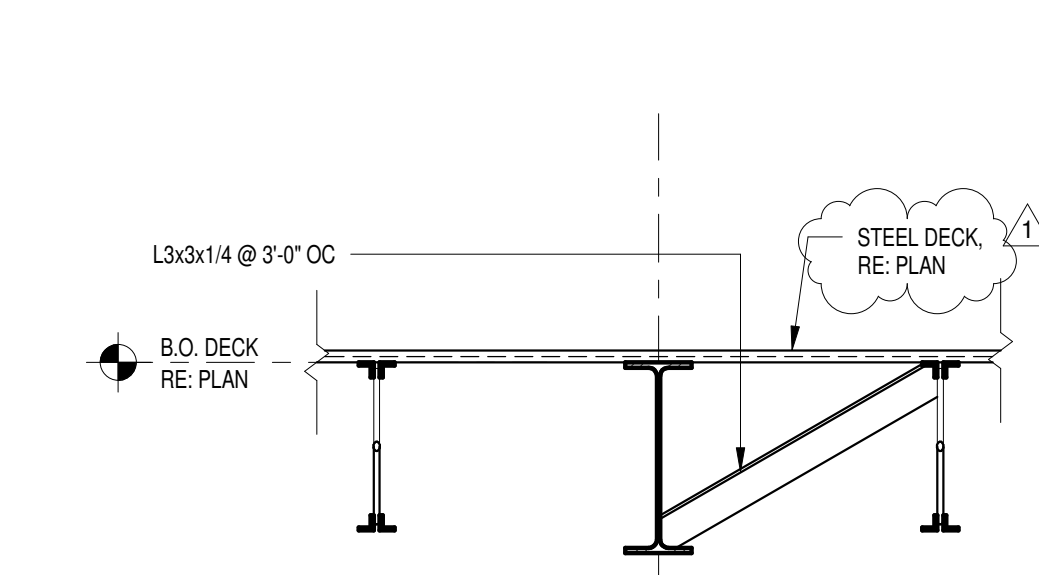

10 SECTION
3/4" = 1'-0"

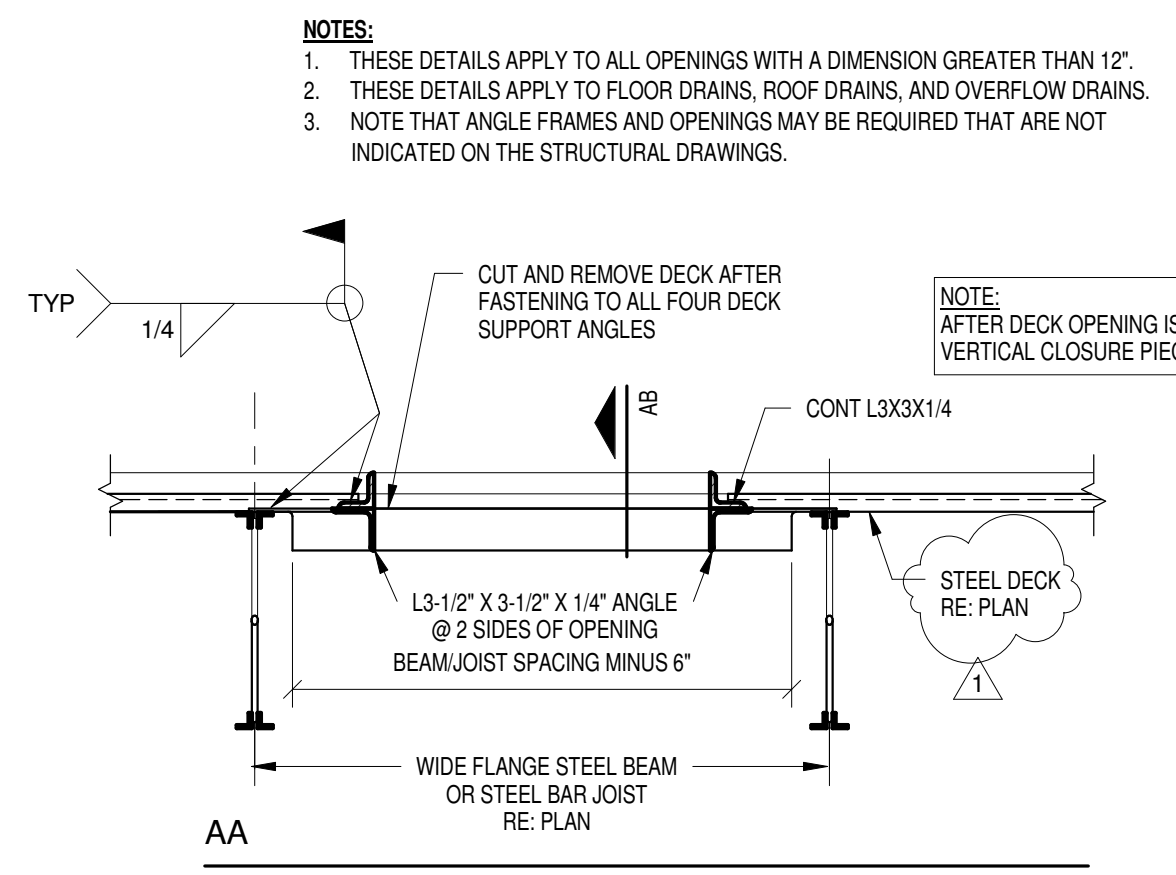

11 TYPICAL ROOF OPENING DETAIL WITH STL JOISTS
3/4" = 1'-0"

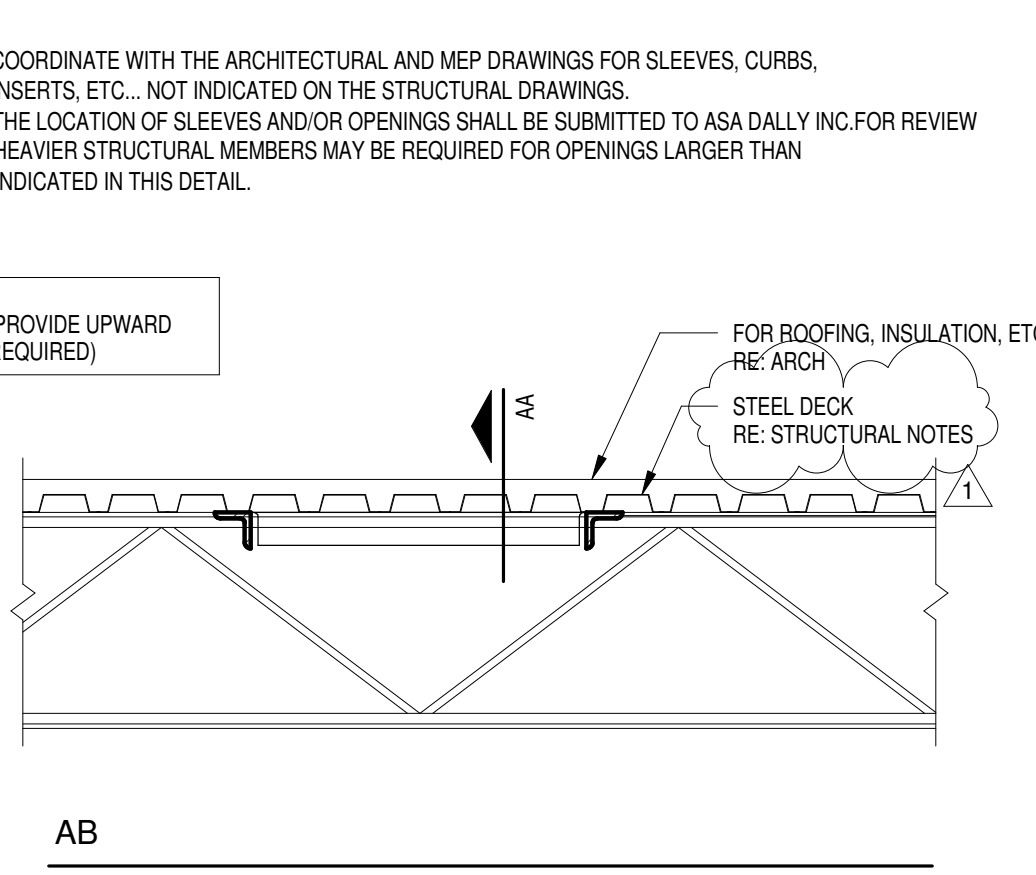

12 SECTION
3/4" = 1'-0"

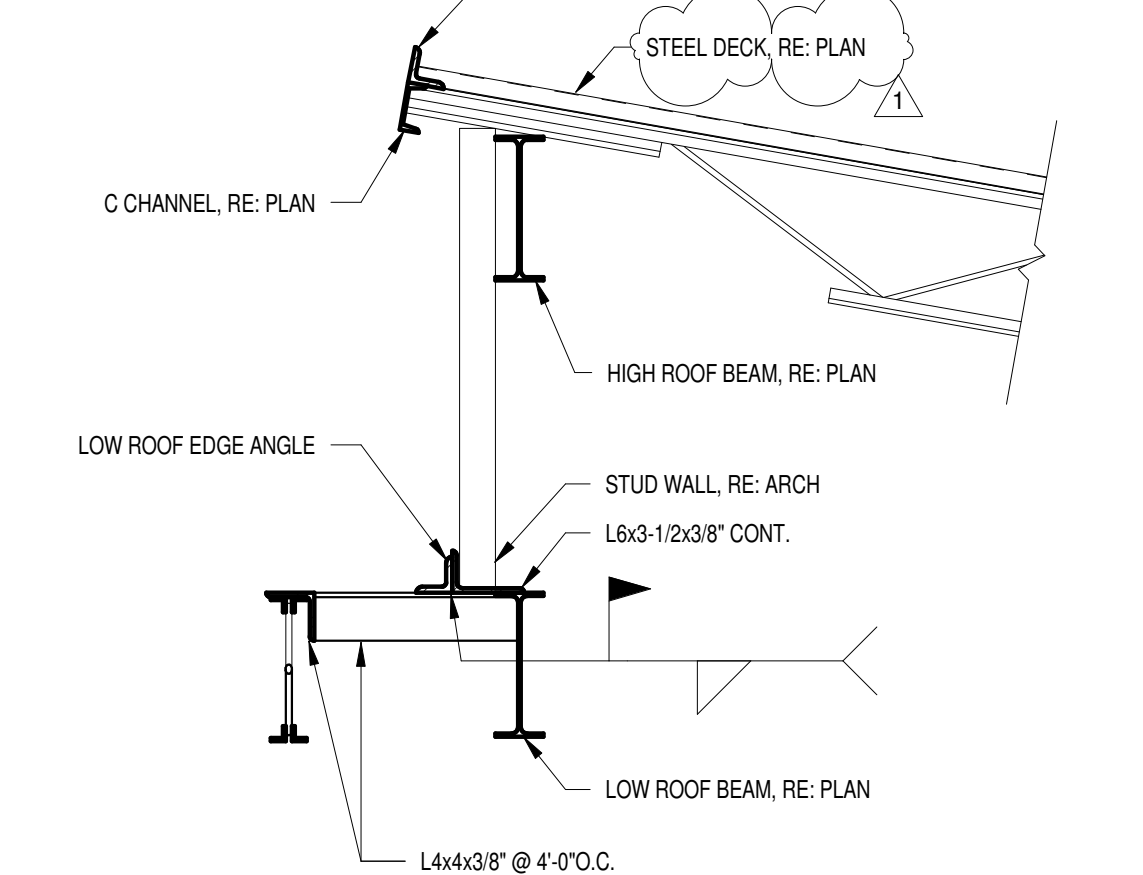

13 SECTION
3/4" = 1'-0"

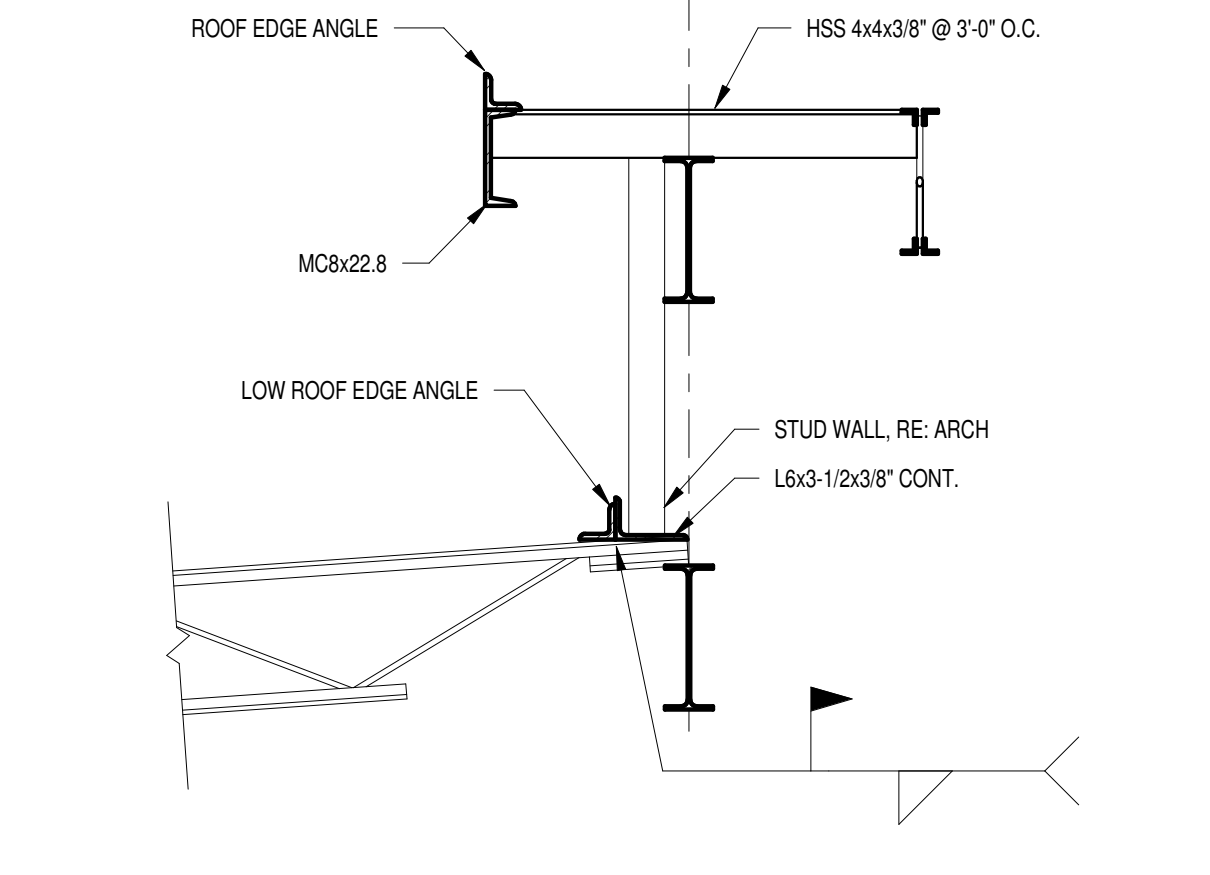

14 SECTION
3/4" = 1'-0"

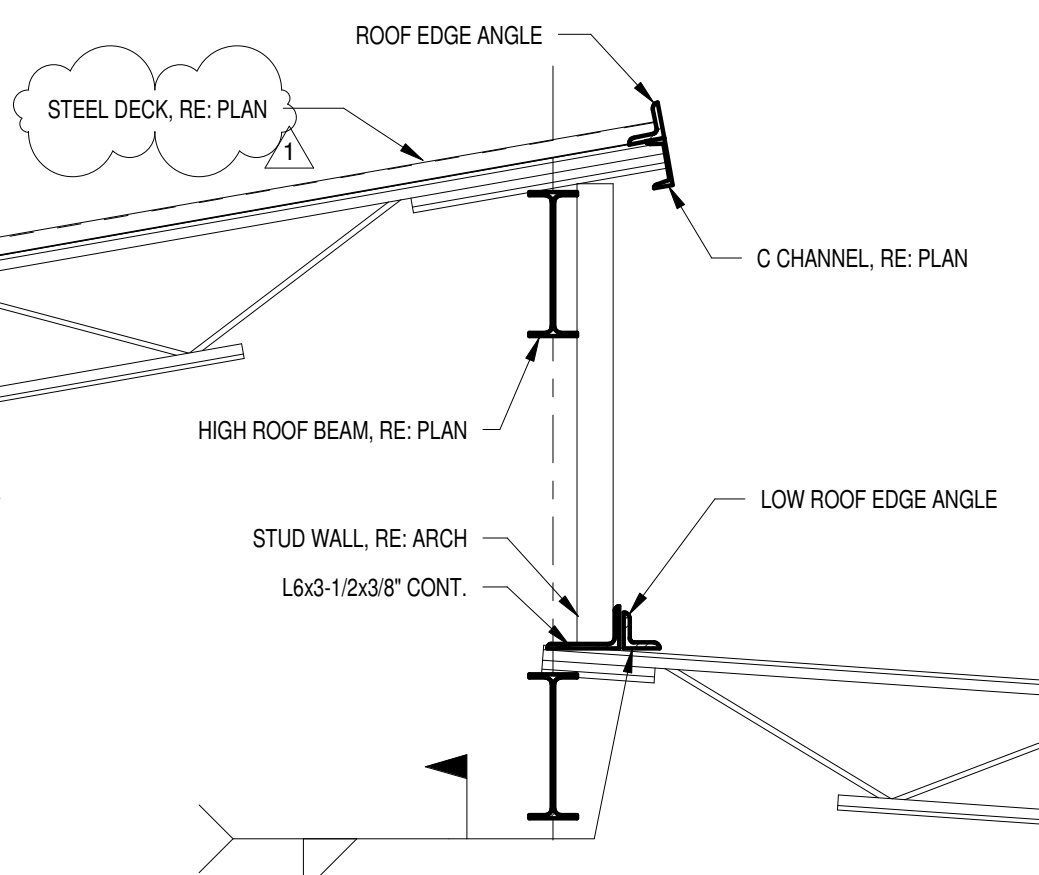

15 SECTION
3/4" = 1'-0"

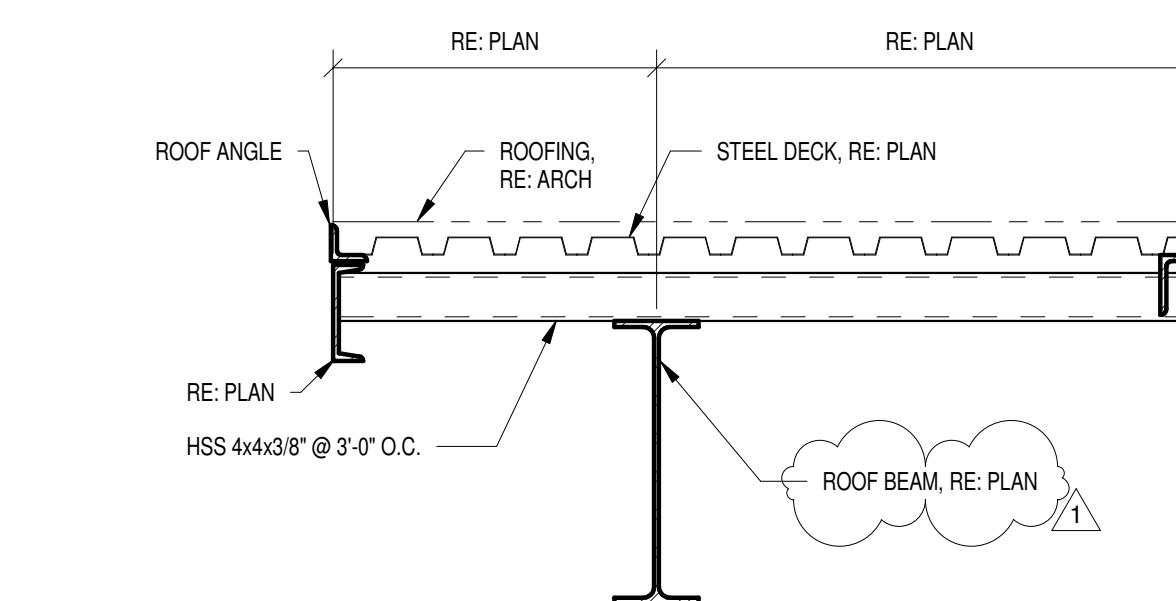

15 CHANNEL @ HIGH ROOF
3/4" = 1'-0"

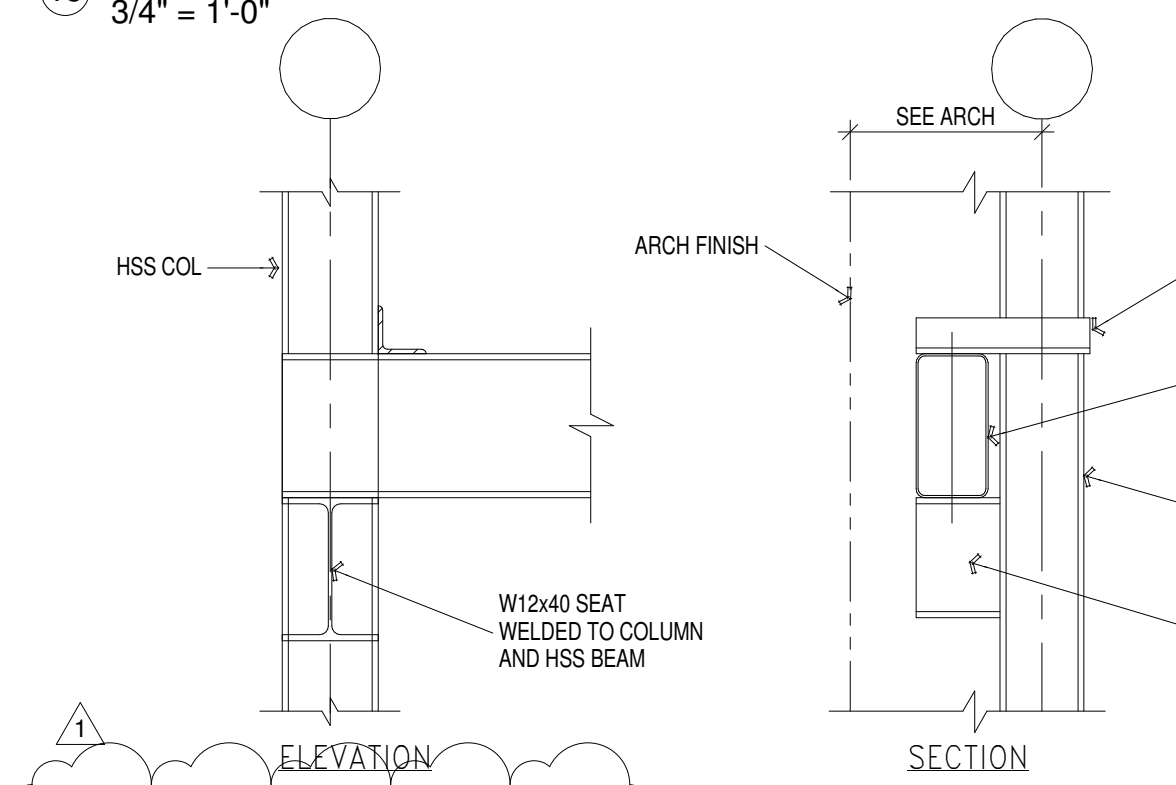

19 OFFSET BEAM TO COLUMN (TYP)
3/4" = 1'-0"

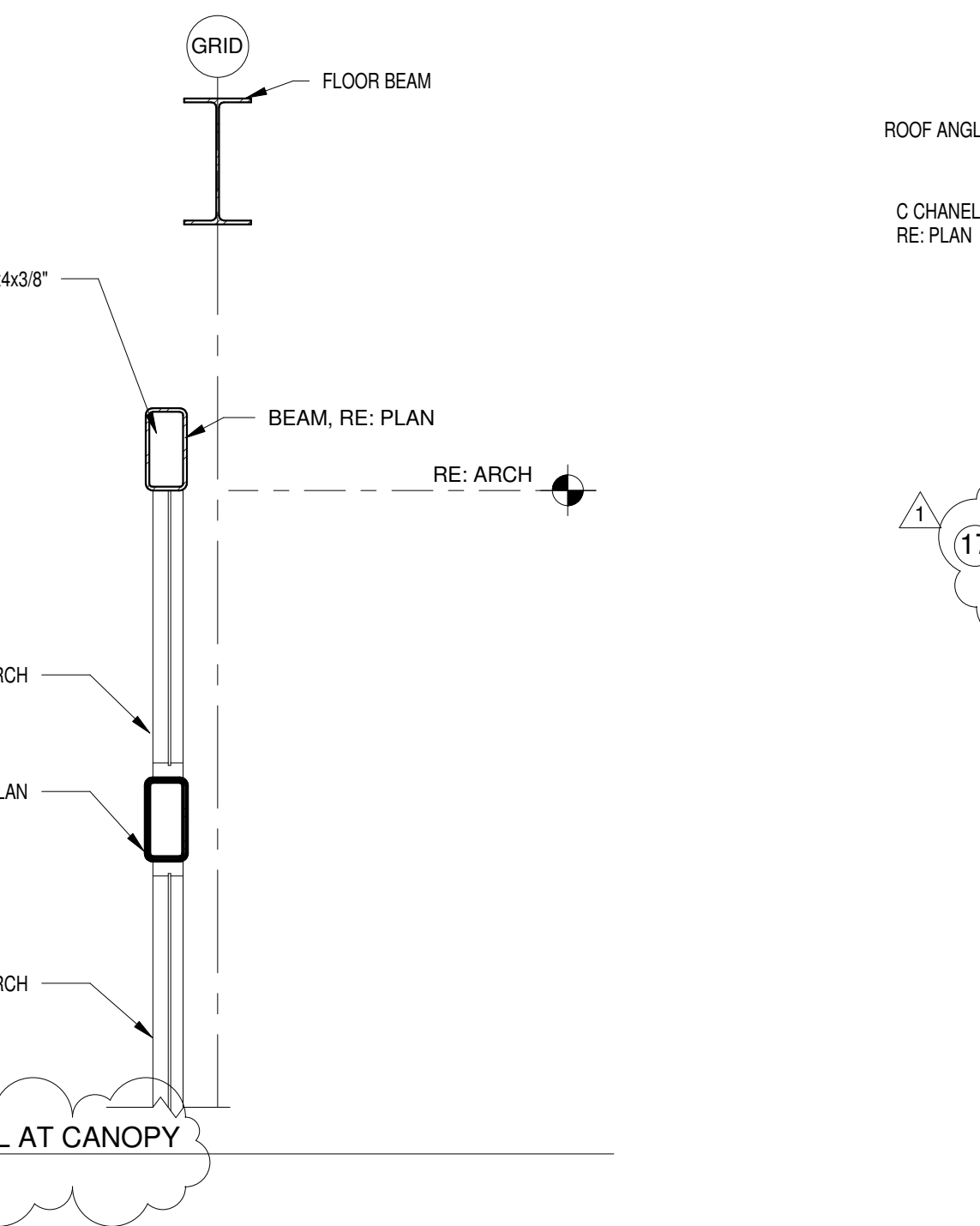

16 TYPICAL DETAIL AT CANOPY
3/4" = 1'-0"

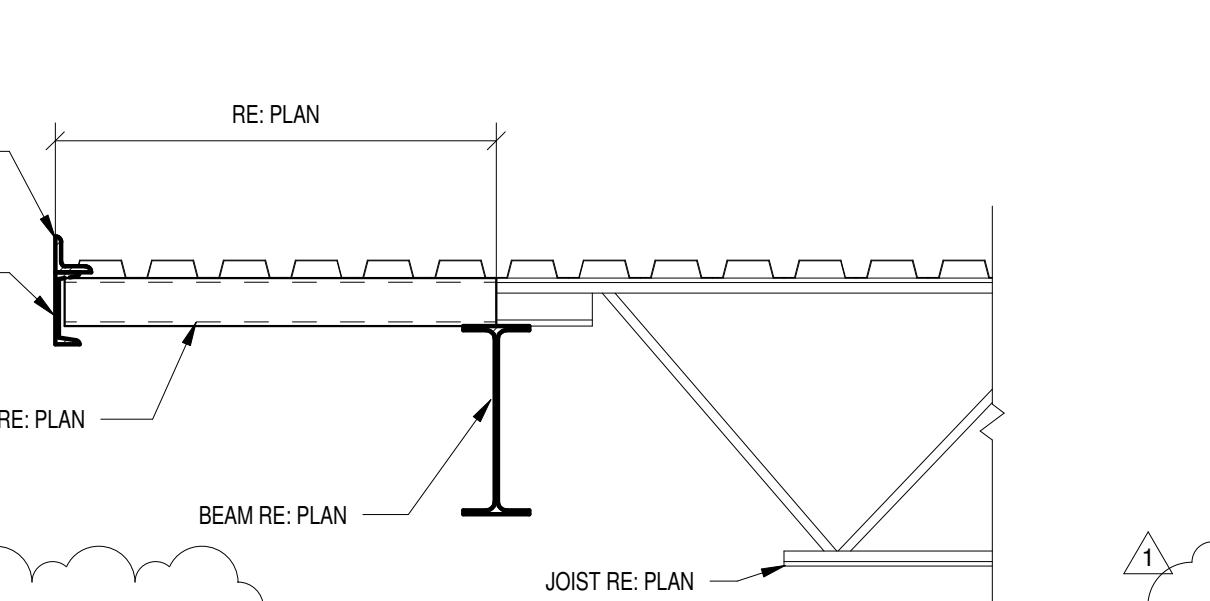

17 SECTION
3/4" = 1'-0"

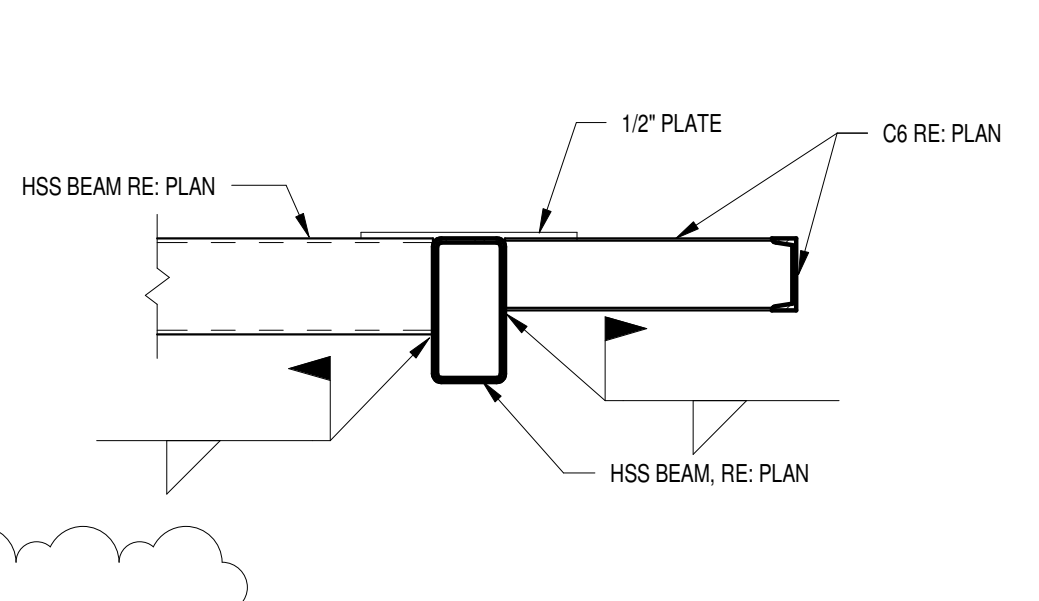

18 SECTION
3/4" = 1'-0"

bdg
architecture
+ planning
boucher design group

Boucher Design Group LLC
Members A.I.A.
6802 Mapleridge, Suite 200
Bellaire, Texas 77401
Tel. 713.785.3644
www.bdgap.com

This document is an instrument of service protected by the copyright law of the United States of America, 17 U.S.C §102, and shall not be copied or reproduced without the express written consent of Boucher Design Group, LLC. 2015

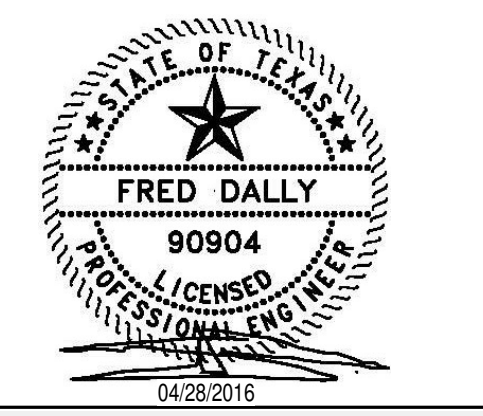

BAYSIDE COMMUNITY CENTER	
BACLIFF, TEXAS	
GALVESTON COUNTY	
DATE	02/29/16
PROJECT NO.	1409000
DRAWN BY	RW
CHECKED BY	FD

**FRAMING
DETAILS**

C:\Users\juser\Desktop\Local Files\2015\15-124-00 Bayshore Community Center - TCH.cvt 5/17/2016 8:09:32 AM

ISSUE #	DATE	DESCRIPTION

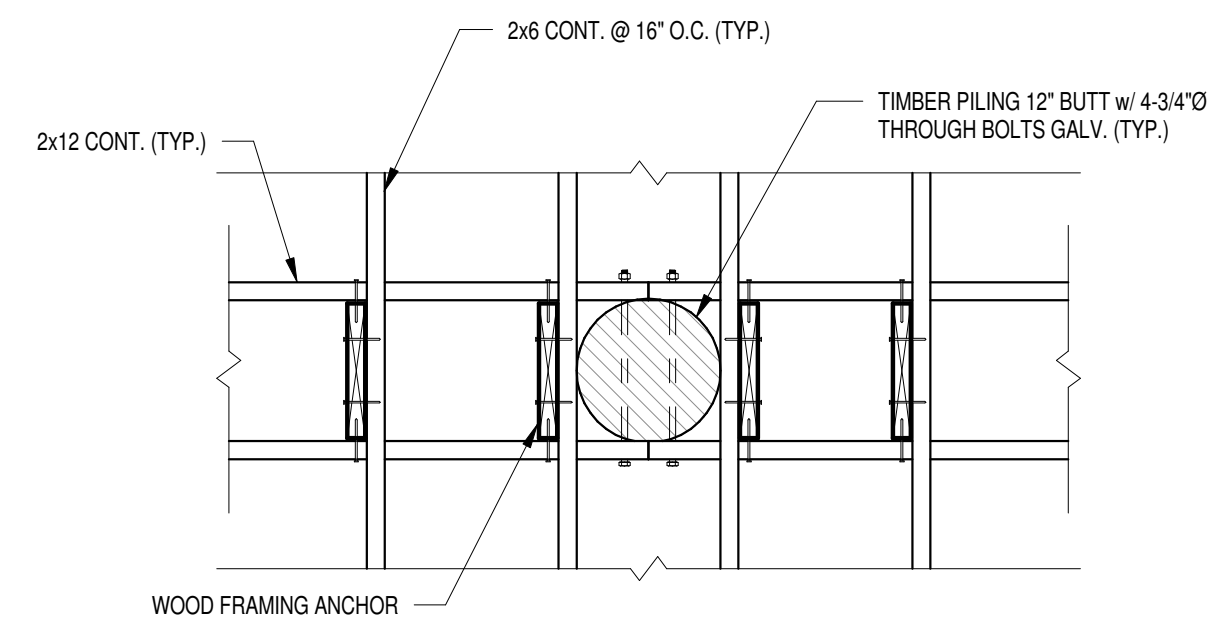

1 BLOCKING DETAIL
3/4" = 1'-0"

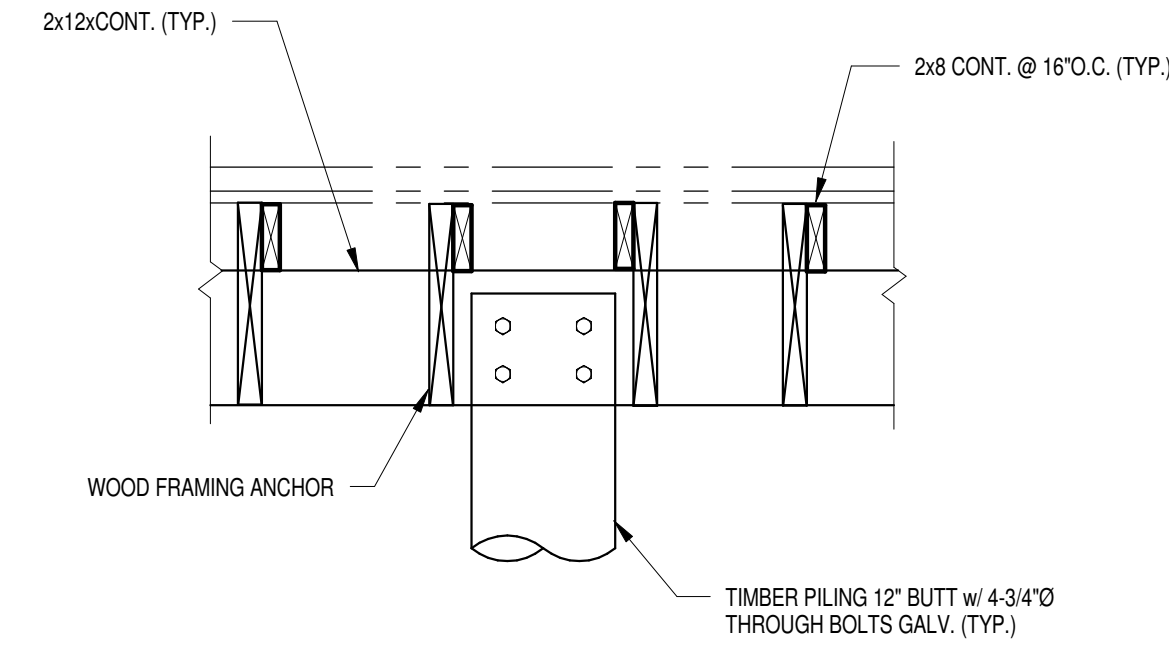

2 BLOCKING SECTION
3/4" = 1'-0"

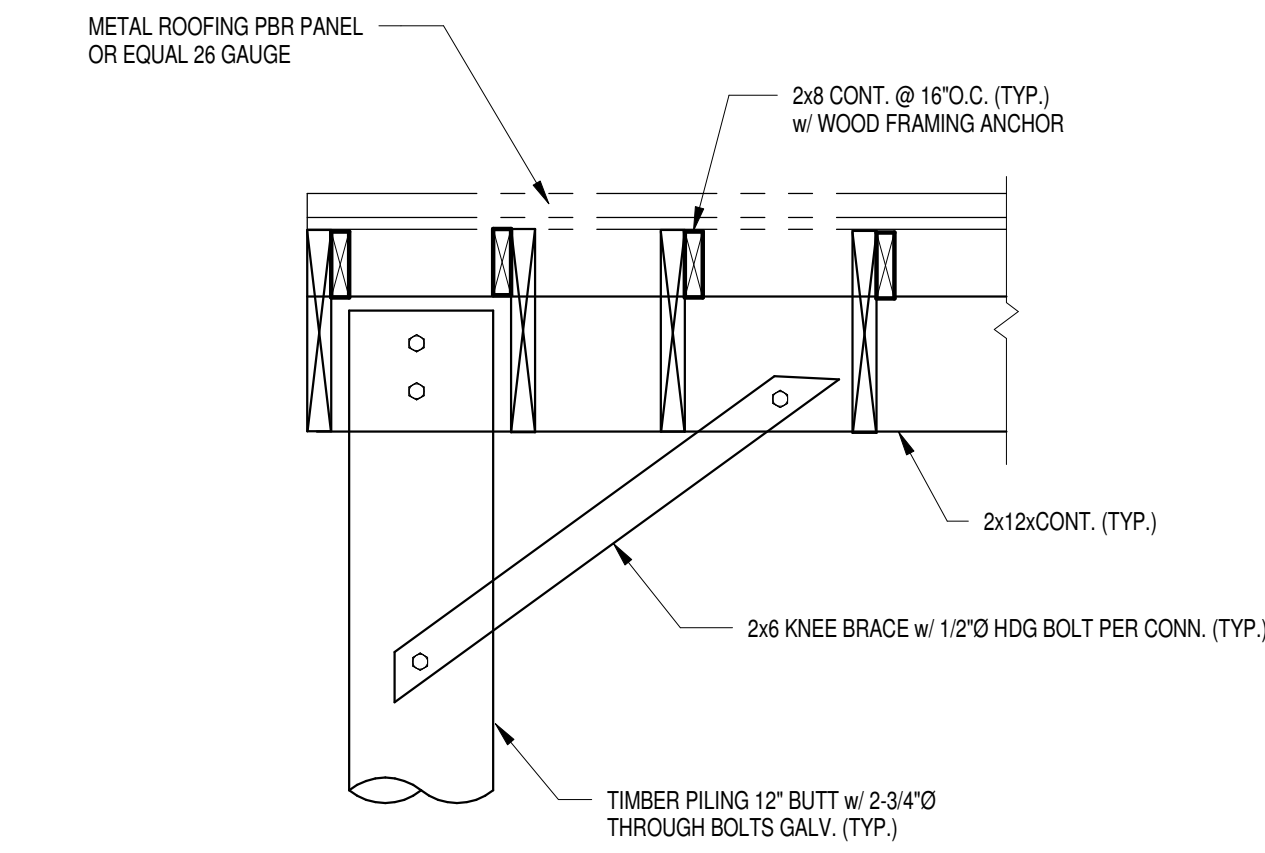

3 KNEE BRACE DETAIL
3/4" = 1'-0"

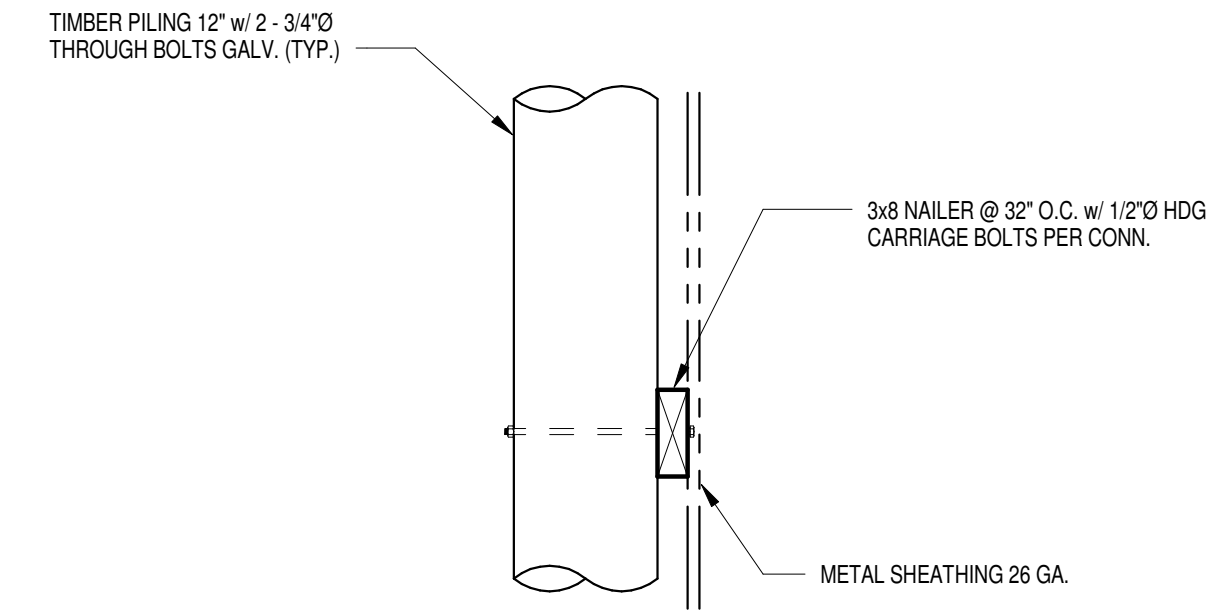

4 SIDING CONN. DETAIL
3/4" = 1'-0"

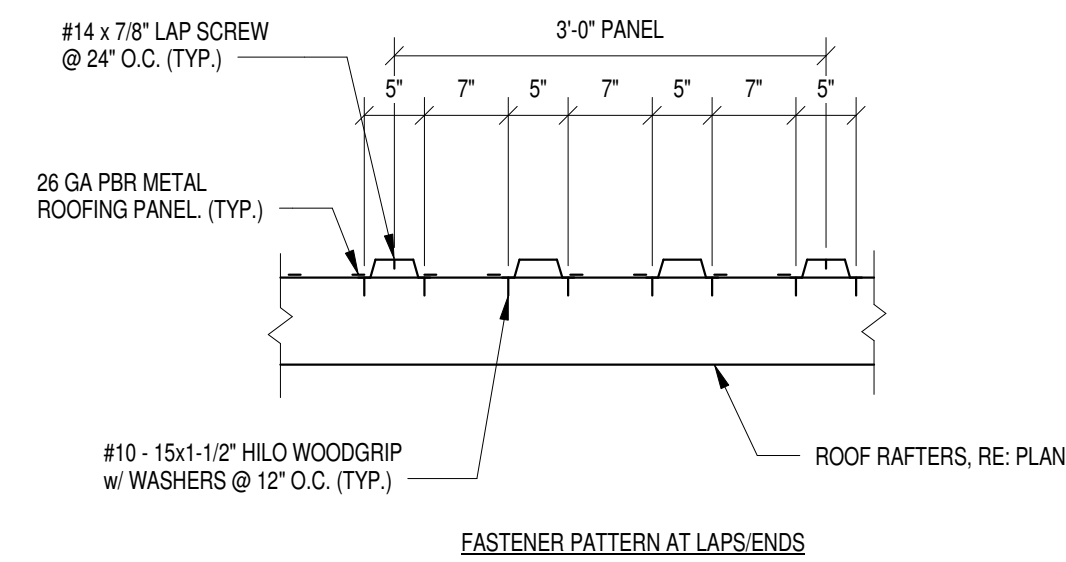
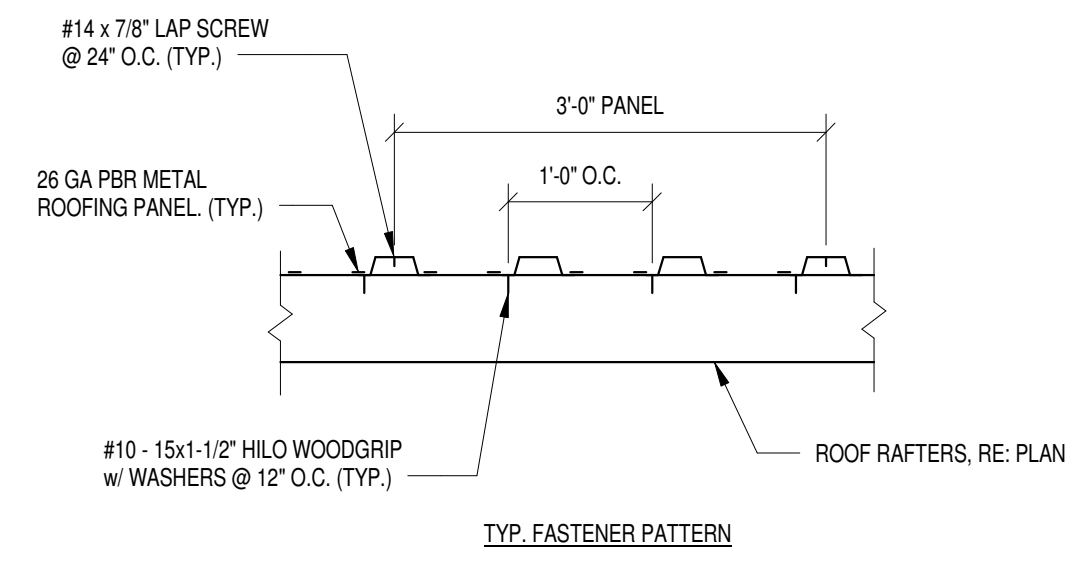

5 ROOF PANEL FASTENER DETAIL
3/4" = 1'-0"

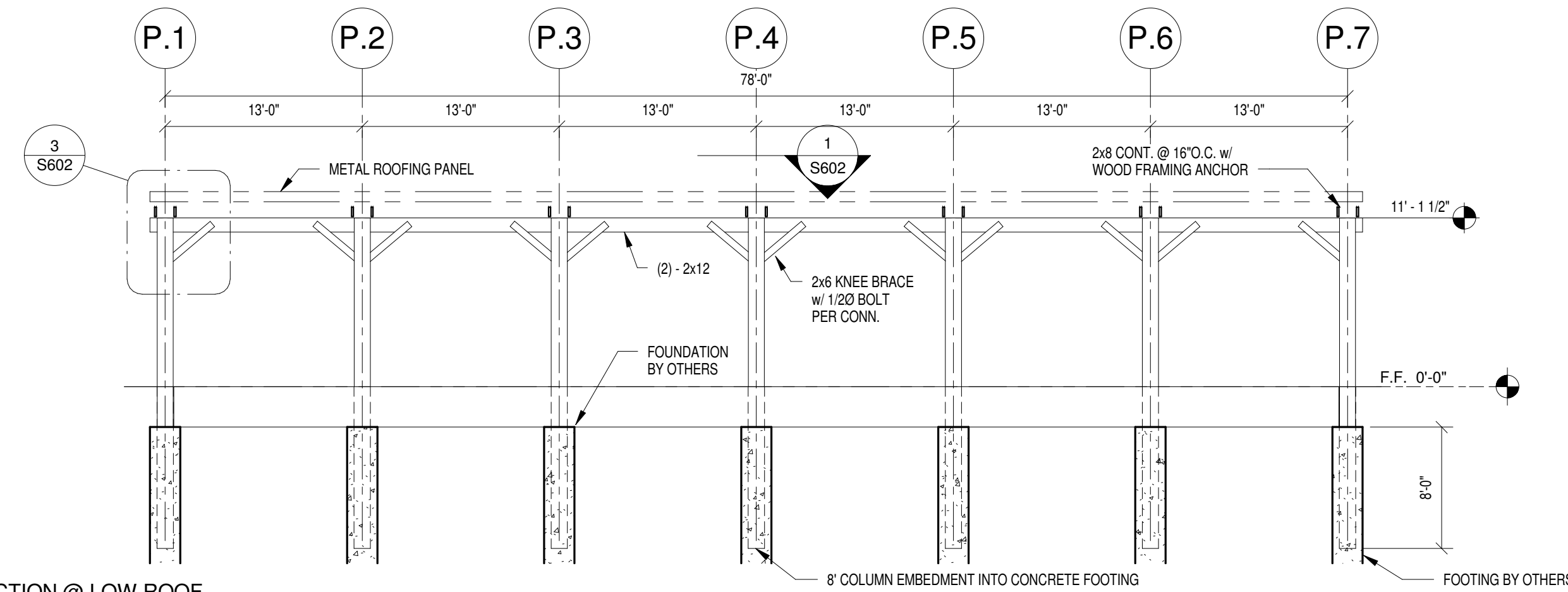

6 SECTION @ LOW ROOF
1/8" = 1'-0"



Boucher Design Group LLC
Members A.I.A.
6802 Mapleridge, Suite 200
Bellaire, Texas 77401
Tel. 713.785.3644
www.bdgap.com

This document is an instrument of service protected by the copyright law of the United States of America, 17 U.S.C. §102, and shall not be copied or reproduced without the express written consent of Boucher Design Group, LLC. 2015



BAYSIDE COMMUNITY CENTER

BACLIFF, TEXAS

GALVESTON COUNTY

DATE	02/29/16
PROJECT NO.	1409000
DRAWN BY	Author
CHECKED BY	Checker

POLE BARN FRAMING

S602

© COPYRIGHT 2016 BOUCHER DESIGN GROUP, LLC

ISSUE #	DATE	DESCRIPTION
1	03-23-2016	ADDENDUM 3

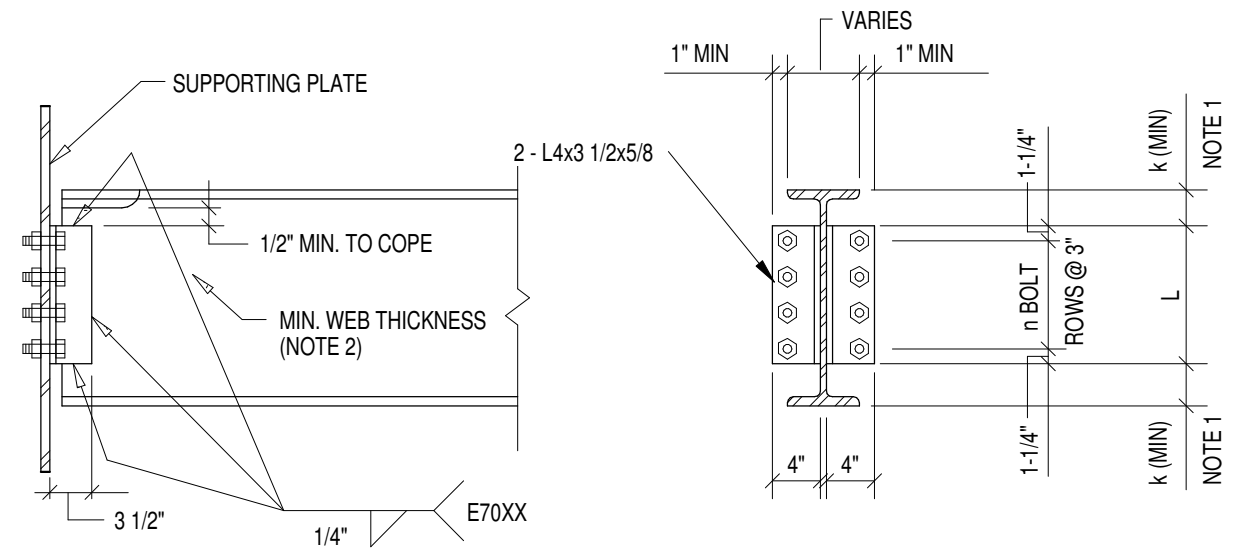

"L"	L (INCHES)	ALLOWABLE BOLT CAPACITY (KIPS)	ALLOWABLE WELD CAPACITY (KIPS)
2	5 1/2"	37	48
3	8 1/2"	56	77
4	11 1/2"	74	100
5	14 1/2"	93	122
6	17 1/2"	111	143
7	20 1/2"	130	160
8	23 1/2"	148	180
9	26 1/2"	167	198
10	29 1/2"	186	215

- NOTES:
- REFER TO AISC - MANUAL OF STEEL CONSTRUCTION (SECTION 1).
 - ALLOWABLE WELD CAPACITY IS BASED UPON A BEAM WEB THICKNESS OF 1/2" FOR A36 MATERIAL AND 3/8" FOR ASTM A572, GRADE 50 MATERIAL. REDUCE THIS CAPACITY PROPORTIONALLY FOR A LESSER WEB THICKNESS.
 - THE SUPPORTING PLATE CAPACITY SHALL BE BASED UPON AN ALLOWABLE LOAD PER BOLT OF 65 KIPS PER INCH OF PLATE THICKNESS FOR A36 MATERIAL OR 73 KIPS PER INCH OF PLATE THICKNESS FOR ASTM A572, GRADE 50 MATERIAL. FOR BEAM CONNECTIONS ON TWO SIDES, THE SUM OF THE LOADS PER BOLT SHALL BE CONSIDERED.
 - FOR COPEDED BEAM CONNECTIONS, THE CAPACITY OF THE NET SHEAR AREA OF THE WEB SHALL BE VERIFIED.
 - THE CAPACITY OF THE CONNECTION SHALL BE THE LESSER VALUE OF THE ALLOWABLE BOLT CAPACITY, ALLOWABLE WELD CAPACITY, SUPPORTING PLATE CAPACITY OR THE WEB NET SHEAR AREA CAPACITY.
 - THE MINIMUM NUMBER OF ROWS OF BOLTS SHALL BE AS FOLLOWS:

W10 & W12	2 ROWS
W14 & W16	3 ROWS
W18, W21, & W24	4 ROWS
W27 & W30	5 ROWS
W33 & W36	6 ROWS

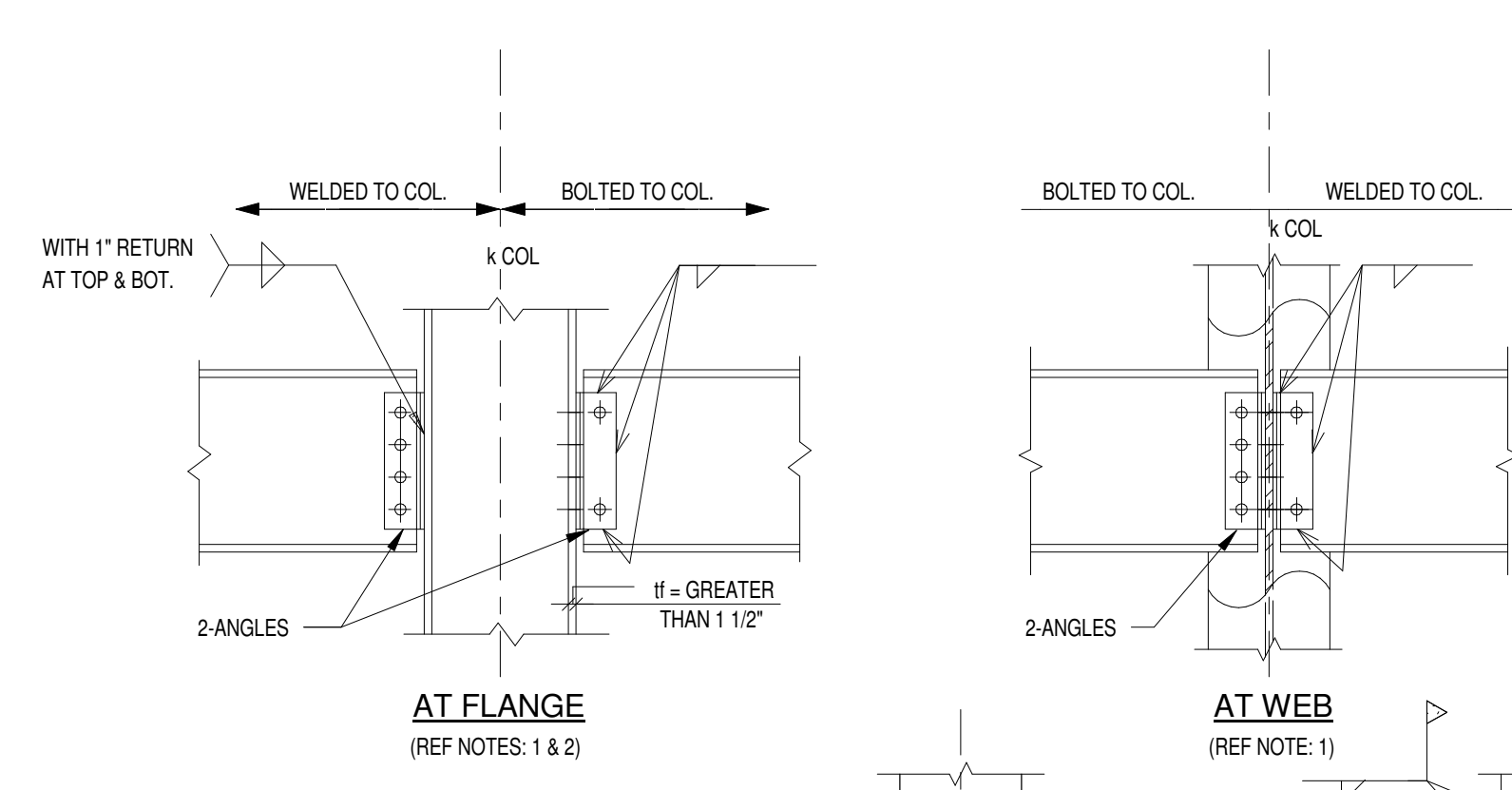

- NOTES:
- CONN. TO BE ADEQUATE FOR AXIAL BRACING FORCE = 1% OF WORKING COLUMN LOAD IN ADDITION TO END REACTION DETERMINED PER STEEL GENERAL NOTES SHEET (U.N.O. ON DWG.) ALLOWABLE STRESS CAN BE INCREASED 1/3 FOR THIS CONDITION. COLUMN LOAD WILL BE FURNISHED OR CAN BE DETERMINED FROM AISC MANUAL FOR FLOOR TO FLOOR HEIGHT.
 - SINGLE PLATE CONNECTION IS ALLOWED ONLY WHEN AXIAL FORCE BRACING THE COLUMN IS LESS THAN 20 KIPS. THE DESIGN OF SINGLE PLATE CONNECTION WITH AXIAL FORCE LESS THAN 20 KIPS, SHOULD BE SUBSTANTIATED BY CALCULATION AND IS SUBJECT TO ENGINEER'S APPROVAL.

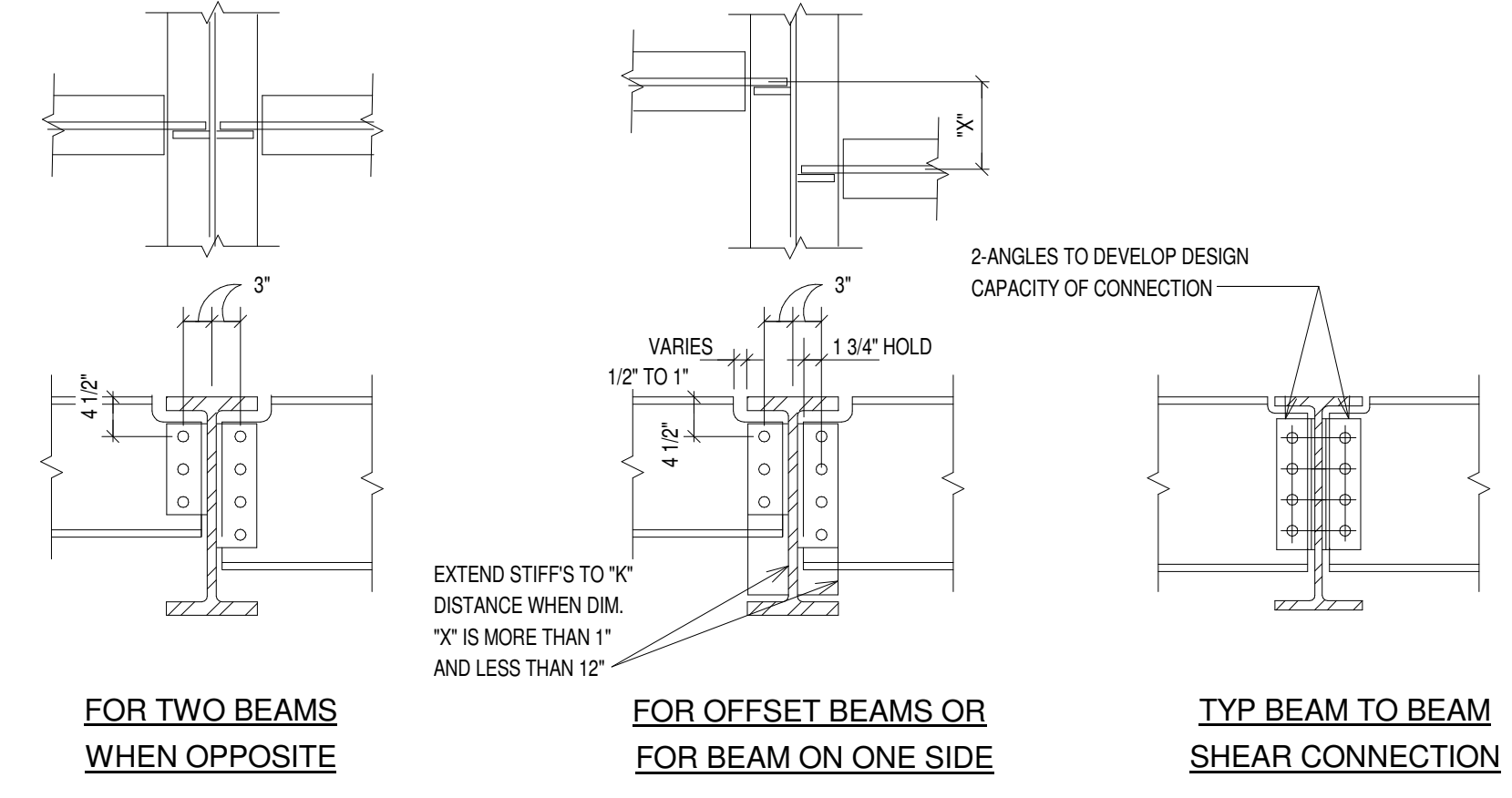
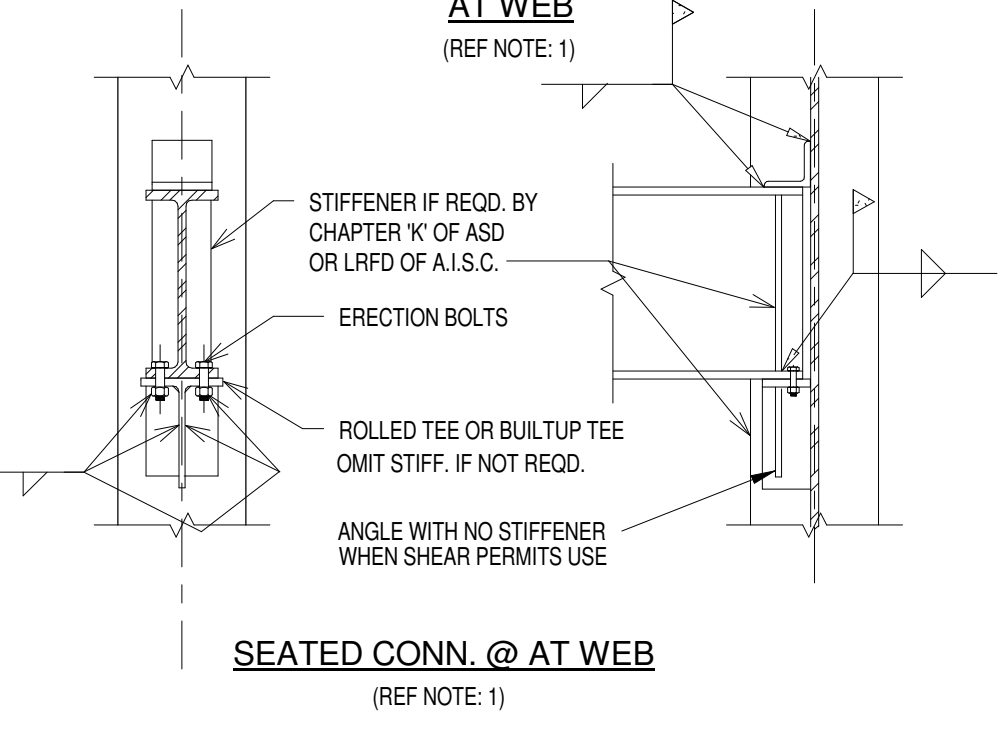

3/4" Ø A325 BOLTS - BEARING CONN. - STANDARD HOLES

- NOTES:
- BOTH THE WELDS & THE BOLTS TO BE DESIGNED FOR MOMENT CAUSED BY ECCENTRICITY BETWEEN WELD GROUP & BOLT CENTERLINE.
 - END REACTION TO BE DETERMINED PER GENERAL NOTES SHEET OR AS SHOWN ON PLANS.

3/4" Ø A325 BOLTS - BEARING CONN. - STANDARD HOLES

1 STANDARD BEAM CONNECTION N.T.S.

2 TYPICAL BEAM TO COLUMN CONNECTION @ FLANGE & WEB N.T.S.

3 BEAM CONNECTION DETAILS 3/4" = 1'-0"

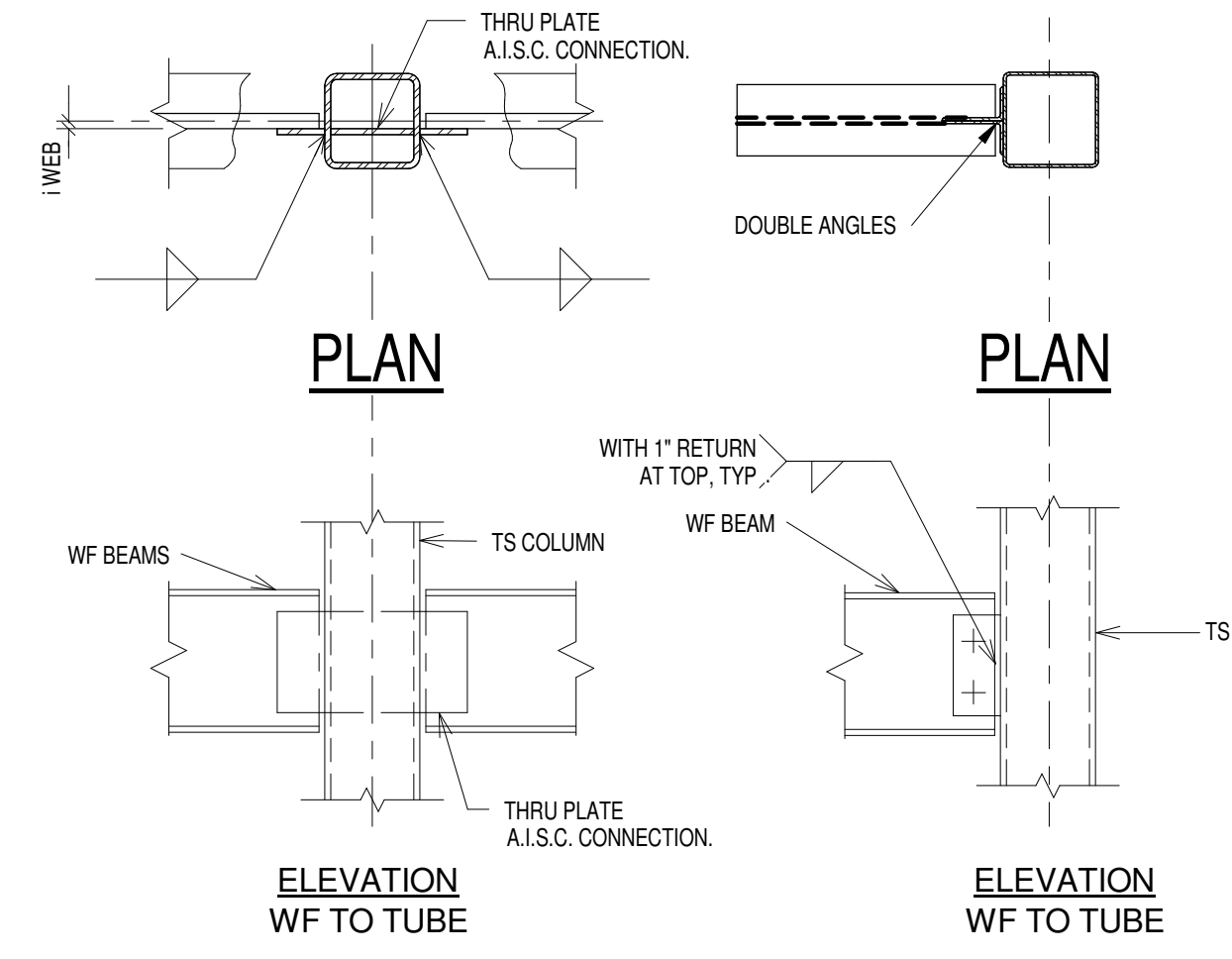

4 BEAM TO TUBE COLUMN SHEAR CONN. NO SCALE 3/4" Ø A325 BOLTS - BEARING CONN. - STANDARD HOLES

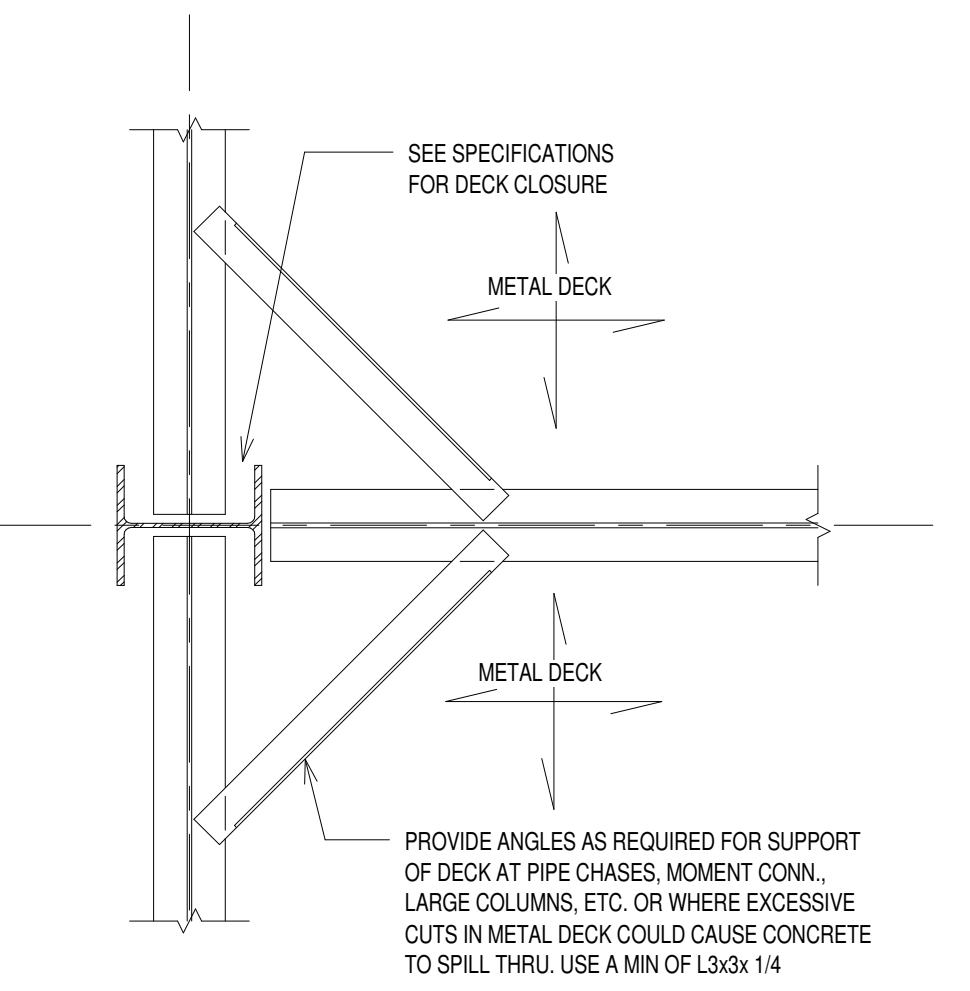

5 TYP. DETAIL FOR SUPPORT OF METAL DECK AT COLUMN NO SCALE 3/4" Ø A325 BOLTS - BEARING CONN. - STANDARD HOLES

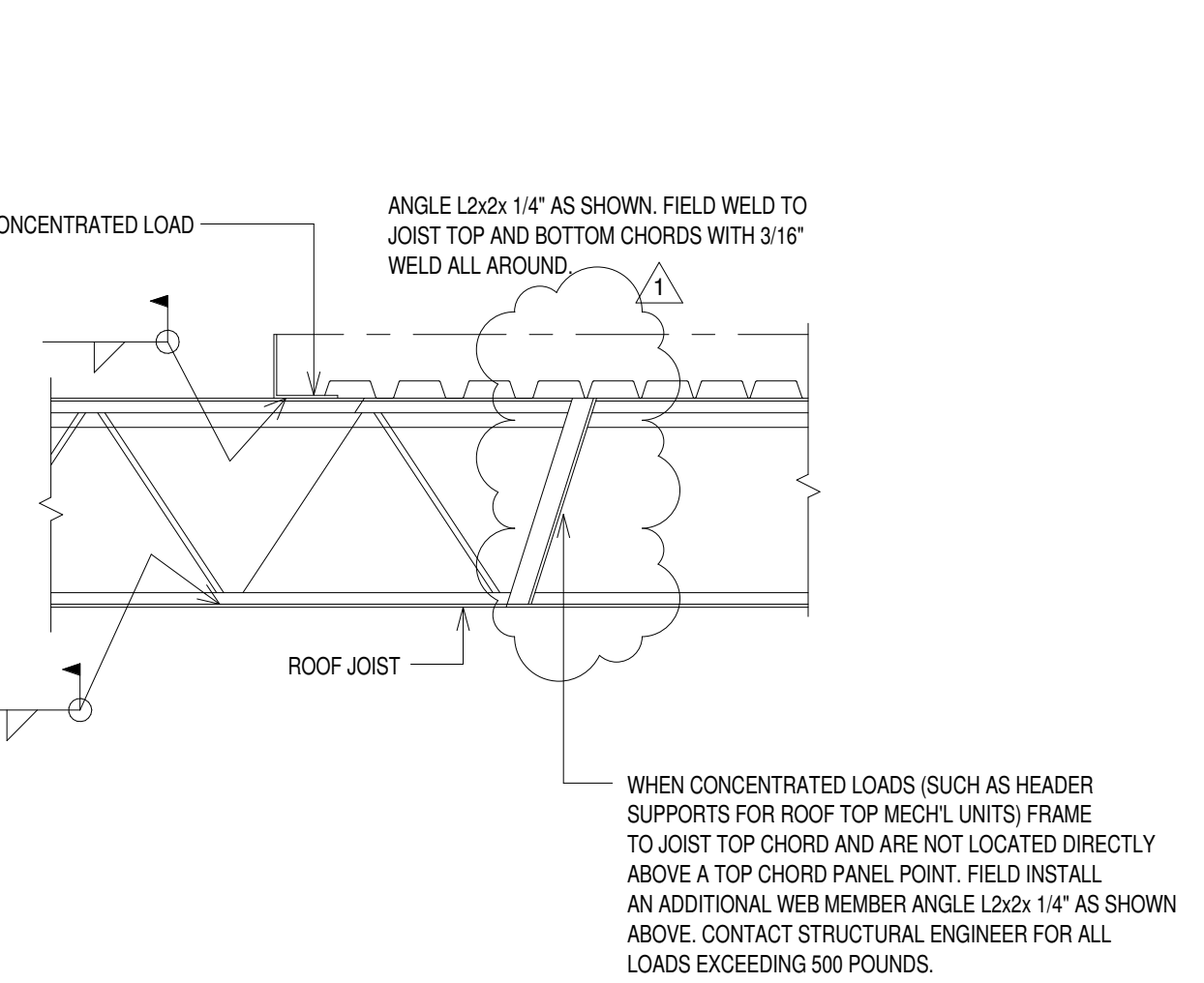

6 LOAD OFFSET FROM JOIST PNL PT. NO SCALE 3/4" Ø A325 BOLTS - BEARING CONN. - STANDARD HOLES

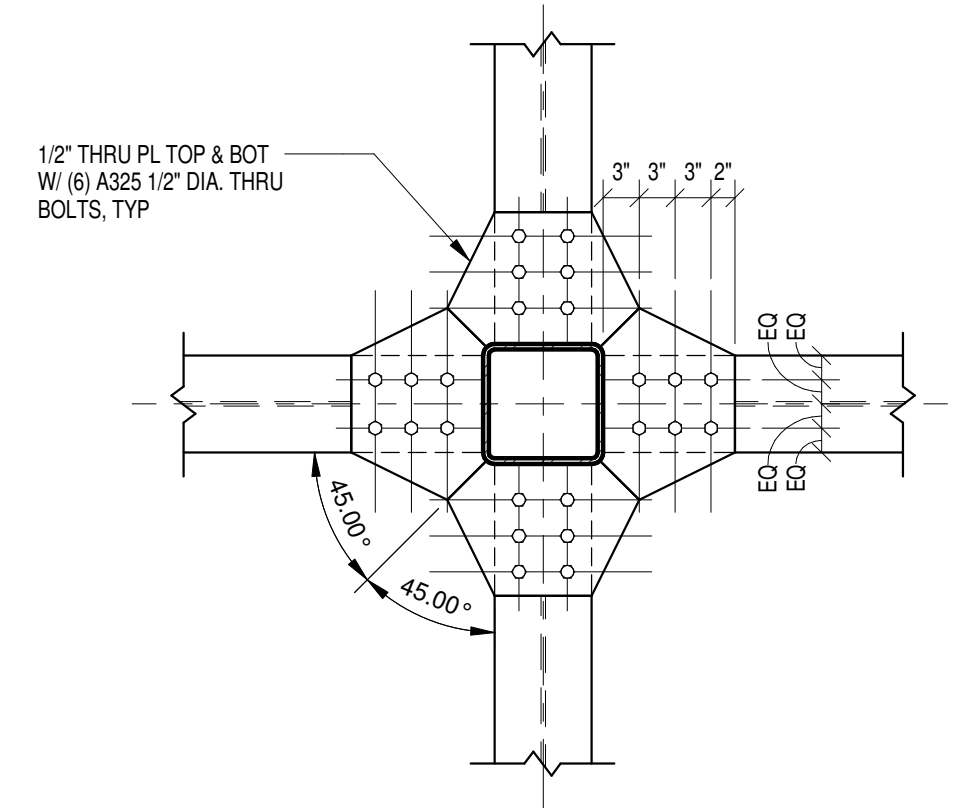

(4) WIDE FLANGE BEAMS TO HSS COL - PLAN

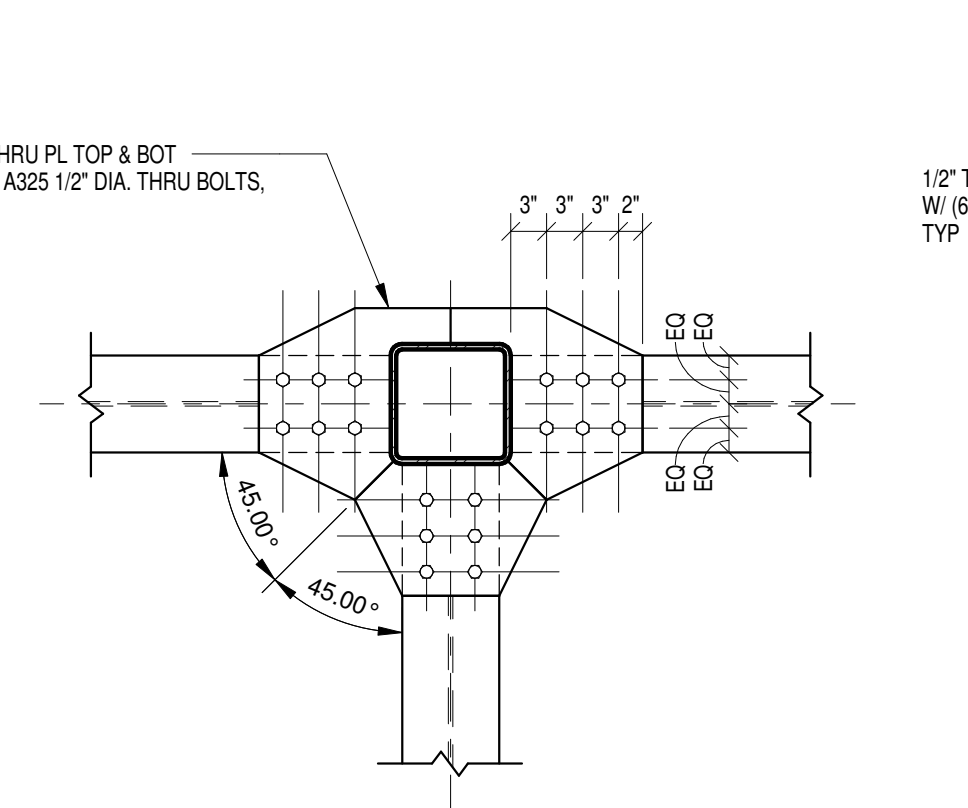

(3) WIDE FLANGE BEAMS TO HSS COL - PLAN

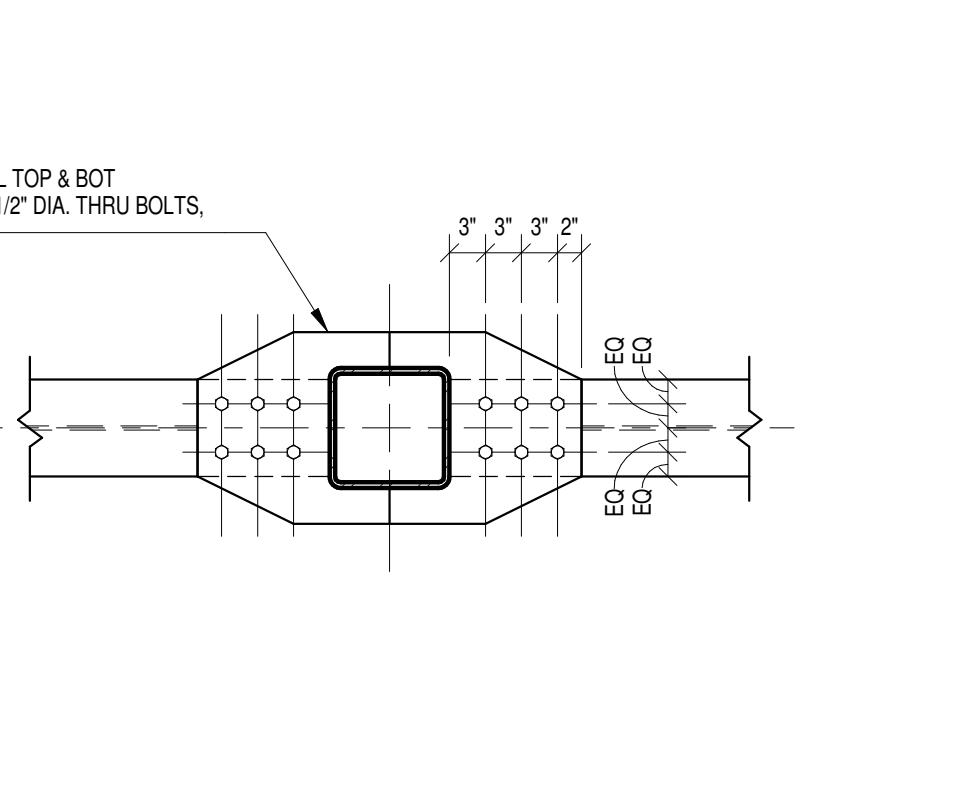

(2) WIDE FLANGE BEAMS TO HSS COL - PLAN

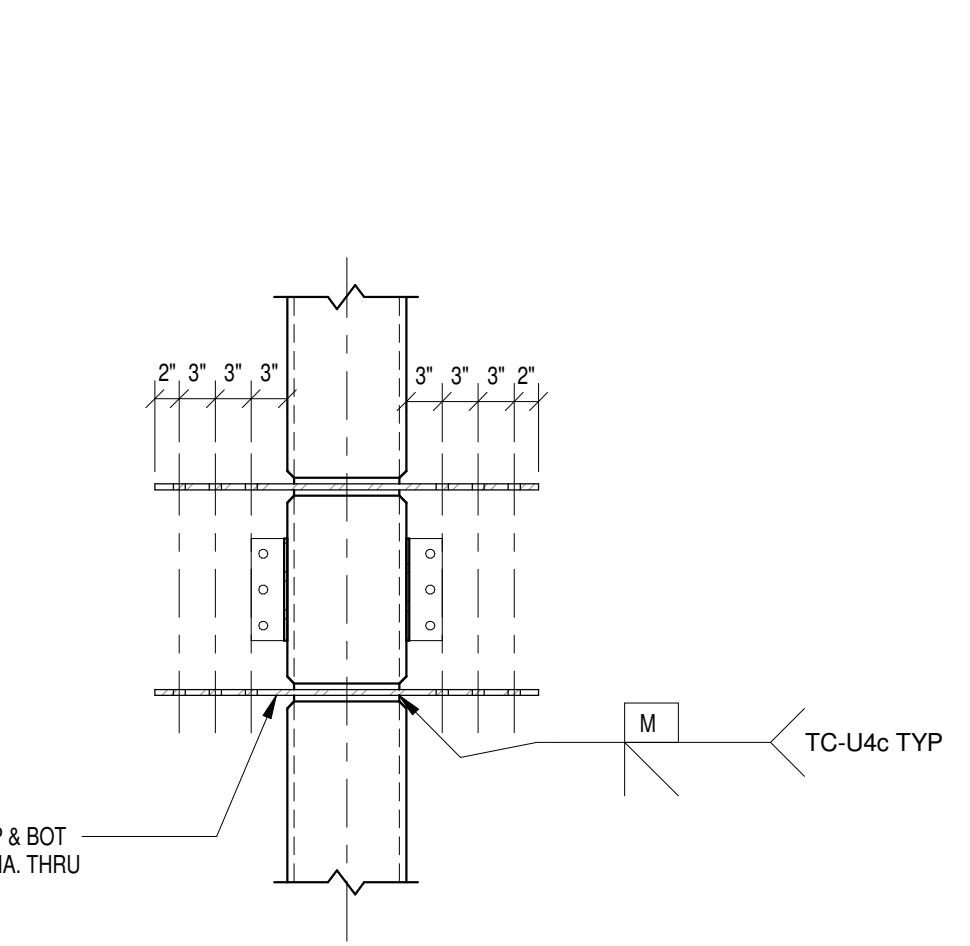

WIDE FLANGE BEAMS NOT SHOWN FOR CLARITY WIDE FLANGE BEAMS TO HSS COL - SECTION

7 HSS COL MOMENT FRAME DETAILS 3/4" = 1'-0"

bdg
architecture + planning
 boucher design group

Boucher Design Group LLC
 Members A.I.A.
 6802 Mapleridge, Suite 200
 Bellaire, Texas 77401
 Tel. 713.785.3644
 www.bdg.com

This document is an instrument of service protected by the copyright law of the United States of America, 17 U.S.C §102, and shall not be copied or reproduced without the express written consent of Boucher Design Group, LLC. 2015

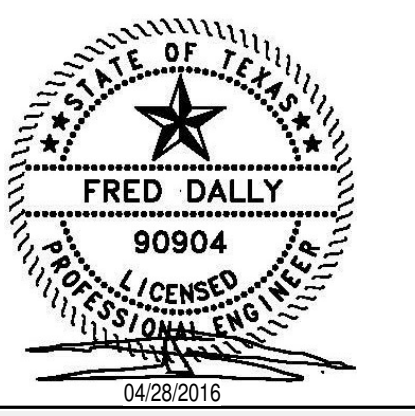

BAYSIDE COMMUNITY CENTER
 BACLIFF, TEXAS
 GALVESTON COUNTY

DATE	02/29/16
PROJECT NO.	1409000
DRAWN BY	RW
CHECKED BY	FD

TYPICAL FRAMING DETAILS

S701
 © COPYRIGHT 2016 BOUCHER DESIGN GROUP, LLC

ISSUE #	DATE	DESCRIPTION
1	02/29/2016	100% CD
2	03/23/2016	Addendum 3
3	05/12/2016	VE Changes

Infrastructure Associates
 INFRASTRUCTURE ASSOCIATES, INC.
 617 RICHMOND AVENUE, SUITE 200
 HOUSTON, TEXAS 77057
 TEPIC REGISTRATION NO. F-4506
 (713) 622-0120 PH (713) 622-0557 FAX
 WWW.IAHOUSTON.COM



Boucher Design Group LLC
 Members A.I.A.
 6802 Maple Ridge, Suite 200
 Bellaire, Texas 77401
 Tel. 713.785.3644
 www.bdgap.com

This document is an instrument of service protected by the copyright law of the United States of America, 17 U.S.C §102, and shall not be copied or reproduced without the express written consent of Boucher Design Group, LLC. 2016



BAYSIDE COMMUNITY CENTER
 BA CLIFF, TEXAS
GALVESTON COUNTY

DATE	02/29/16
PROJECT NO.	1409000
DRAWN BY	OC/CJCT
CHECKED BY	WJK/DG

SITE PLAN

MEP101

© COPYRIGHT 2016 BOUCHER DESIGN GROUP, LLC

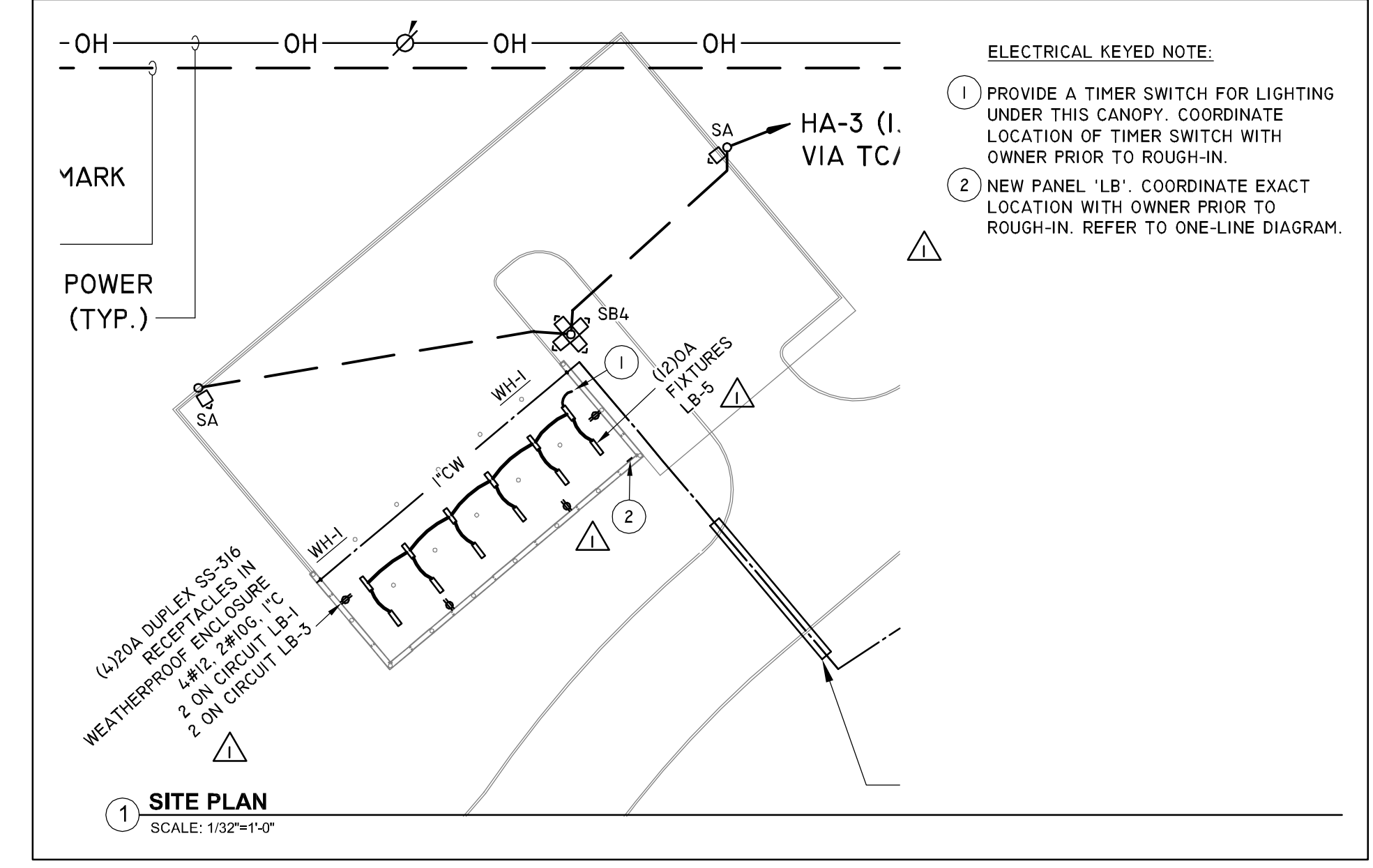
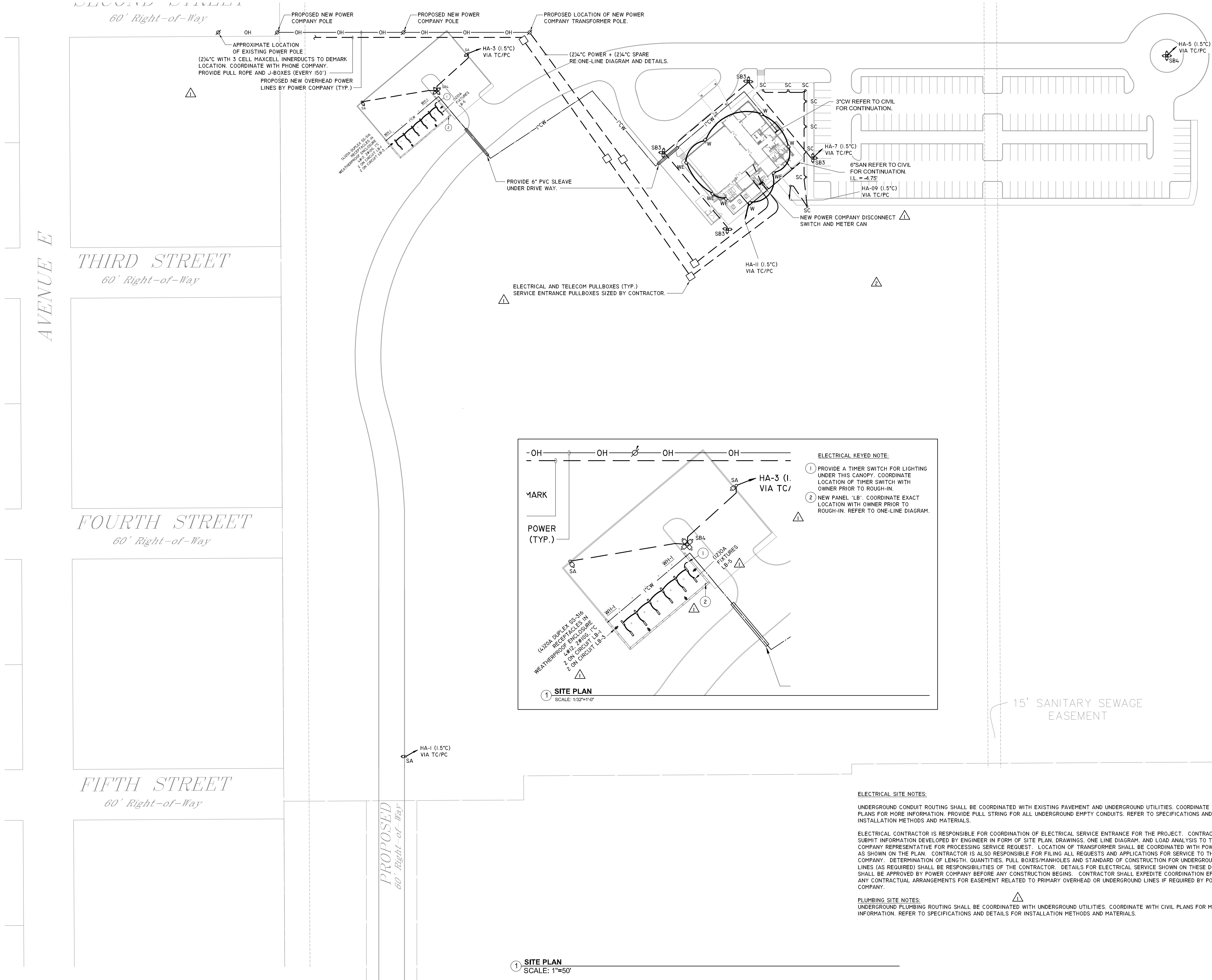

- ELECTRICAL KEYED NOTE:**
- 1 PROVIDE A TIMER SWITCH FOR LIGHTING UNDER THIS CANOPY. COORDINATE LOCATION OF TIMER SWITCH WITH OWNER PRIOR TO ROUGH-IN.
 - 2 NEW PANEL 'LB'. COORDINATE EXACT LOCATION WITH OWNER PRIOR TO ROUGH-IN. REFER TO ONE-LINE DIAGRAM.

ELECTRICAL SITE NOTES:
 UNDERGROUND CONDUIT ROUTING SHALL BE COORDINATED WITH EXISTING PAVEMENT AND UNDERGROUND UTILITIES. COORDINATE WITH CIVIL PLANS FOR MORE INFORMATION. PROVIDE PULL STRING FOR ALL UNDERGROUND EMPTY CONDUITS. REFER TO SPECIFICATIONS AND DETAILS FOR INSTALLATION METHODS AND MATERIALS.

ELECTRICAL CONTRACTOR IS RESPONSIBLE FOR COORDINATION OF ELECTRICAL SERVICE ENTRANCE FOR THE PROJECT. CONTRACTOR SHALL SUBMIT INFORMATION DEVELOPED BY ENGINEER IN FORM OF SITE PLAN, DRAWINGS, ONE LINE DIAGRAM, AND LOAD ANALYSIS TO THE POWER COMPANY REPRESENTATIVE FOR PROCESSING SERVICE REQUEST. LOCATION OF TRANSFORMER SHALL BE COORDINATED WITH POWER COMPANY AS SHOWN ON THE PLAN. CONTRACTOR IS ALSO RESPONSIBLE FOR FILING ALL REQUESTS AND APPLICATIONS FOR SERVICE TO THE POWER COMPANY. DETERMINATION OF LENGTH, QUANTITIES, PULL BOXES/MANHOLES AND STANDARD OF CONSTRUCTION FOR UNDERGROUND PRIMARY LINES (AS REQUIRED) SHALL BE RESPONSIBILITIES OF THE CONTRACTOR. DETAILS FOR ELECTRICAL SERVICE SHOWN ON THESE DOCUMENTS SHALL BE APPROVED BY POWER COMPANY BEFORE ANY CONSTRUCTION BEGINS. CONTRACTOR SHALL EXPEDITE COORDINATION EFFORT FOR ANY CONTRACTUAL ARRANGEMENTS FOR EASEMENT RELATED TO PRIMARY OVERHEAD OR UNDERGROUND LINES IF REQUIRED BY POWER COMPANY.

PLUMBING SITE NOTES:
 UNDERGROUND PLUMBING ROUTING SHALL BE COORDINATED WITH UNDERGROUND UTILITIES. COORDINATE WITH CIVIL PLANS FOR MORE INFORMATION. REFER TO SPECIFICATIONS AND DETAILS FOR INSTALLATION METHODS AND MATERIALS.

1 SITE PLAN
 SCALE: 1"=50'

2/26/2016 2:34:17 PM

MECHANICAL SYMBOLS LEGEND

	SUPPLY AIR DUCT UP (PLAN)		DIFFUSER TYPE, NECK SIZE, CFM		CHECK VALVE, SWING GATE
	SUPPLY AIR DUCT DOWN (PLAN)	T	THERMOSTAT - MOUNT 48" AFF UNO		ANGLE PRESSURE RELIEF VALVE
	RETURN OR OUTSIDE AIR DUCT UP (PLAN)	H	HUMIDISTAT		PRESSURE REDUCING VALVE
	RETURN OR OUTSIDE AIR DUCT DOWN (PLAN)	F	FIRESTAT		LOCK SHIELD
	EXHAUST AIR DUCT UP (PLAN)	ID	IONIZATION DETECTOR		QUICK OPENING/CLOSING VALVE
	EXHAUST AIR DUCT DOWN (PLAN)	SD	SMOKE DETECTOR		PRESSURE REGULATOR
	RETURN AIR/TRANSFER AIR BOOT		PIPE UP		STRAINER W/BLOW DOWN VALVE
	CEILING SUPPLY AIR DEVICE		PIPE DOWN		THREE-WAY VALVE (ELECTRIC)
	SIDEWALL SUPPLY/EXHAUST REGISTER		CAP		TWO-WAY VALVE (ELECTRIC)
	CEILING RETURN AIR / EXHAUST REGISTER		90° ELBOW		FLEXIBLE CONNECTION
	RETURN AIR GRILLE WITH BOOT		45° ELBOW		EXPANSION JOINT
	BRANCH DUCT TAP		45° ELBOW DOWN (OGEE)		THERMOMETER
	DUCT SPLIT WITH SPLITTER DAMPER		TEE		THERMOMETER WELL
	ACCESS DOOR		TEE UP		TEST PLUG
	TRANSITION IN DUCT		TEE DOWN		PRESSURE GAUGE W/GAUGE COCK
	FLEXIBLE DUCT CONN. TO RECTANGULAR DUCT WITH SPIN-IN CONNECTOR		TOP CONNECTION		MANUAL AIR VENT
	ACCESS PANEL		CROSS		AUTOMATIC AIR VENT
	DUCT ELBOW WITH TURNING VANES		UNION (SCREWED)		SOLENOID VALVE
	DUCT ELBOW WITHOUT VANES		UNION (FLANGED)		FLOW SWITCH
	FLEXIBLE CONNECTION, FLEXIBLE DUCT	T	DUCT MOUNTED TEMPERATURE SENSOR		TEMPERATURE AND PRESSURE RELIEF VALVE
	VOLUME DAMPER	P	DUCT MOUNTED PRESSURE SENSOR		STEAM TRAP
	MOTORIZED VOLUME DAMPER	SD	DUCT MOUNTED SMOKE DETECTOR		STEAM MOISTURE SEPARATOR
	FIRE DAMPER		PIPE BREAK		CONTROL, ELECTRIC-PNEUMATIC
	SMOKE DAMPER		CONCENTRIC REDUCER		CONTROL, PNEUMATIC-ELECTRIC
	COMBINATION FIRE/SMOKE DAMPER		ECCENTRIC REDUCER		RED. PRESS PRINCIPAL BACKFLOW PREVENTER
	AIR FLOW SWITCH		END SUCTION PUMP		CHILLED WATER RETURN
	AIR PRESSURE DIFFERENTIAL SWITCH		BALL VALVE		CHILLED WATER SUPPLY
	RISE IN DUCT ELEVATION		BUTTERFLY VALVE		CONDENSER WATER RETURN
	DROP IN DUCT ELEVATION		ISOLATION VALVE		CONDENSER WATER SUPPLY
	SPLITTER DAMPER - DIMENSION AS NOTED ON DRAWING		GATE VALVE WITH QUICK DISCONNECT		HOT WATER RETURN
	BACK DRAFT DAMPER		TWO-WAY VALVE (PNEUMATIC)		HOT WATER SUPPLY
	UNDERCUT DOOR 1'		THREE-WAY VALVE (PNEUMATIC)		CONDENSATE DRAIN
RE: 1/M-7	REFER TO DETAIL #1 ON DRAWING M-7		BALANCING VALVE		HEAT RECOVERY SUPPLY
(E)	EXISTING TO REMAIN		PNEUMATIC MOTOR		HEAT RECOVERY RETURN
(D)	EXISTING TO BE DEMOLISHED		CONNECT TO EXISTING		STEAM CONDENSATE
(N)	NEW EQUIPMENT	(R/A)	RETURN AIR		
(S/A)	SUPPLY AIR	(E/A)	EXHAUST AIR		

NOTE:
NOT ALL ITEMS NOT NECESSARILY USED.

MECHANICAL GENERAL NOTES

- SEE ARCHITECTURAL PLANS FOR TYPE OF CEILING AND LOCATIONS OF WALL MOUNTED DEVICES.
- DO NOT OPERATE AIR HANDLERS OR EXHAUST FANS UNTIL ALL INTERIOR CLEANING AND PAINTING IS COMPLETE. THE CLEANING OF FOULED COILS OR FAN ASSEMBLIES DUE TO PAINT OR CONSTRUCTION DEBRIS WILL BE THE RESPONSIBILITY OF THE HVAC CONTRACTOR.
- RECTANGULAR DUCT SIZES INDICATED ARE ACTUAL SHEET METAL DIMENSIONS IN INCHES ALL ROUND DUCT SIZES INDICATE NET FREE INSIDE DIAMETER AND DO NOT ACCOUNT FOR ANY INSULATION. ROUND DUCTS AND RECTANGULAR DUCTS ARE EXTERNALLY INSULATED PER SPECIFICATIONS. ALL DUCTWORK SHALL BE INSTALLED AND MANUFACTURED IN ACCORDANCE WITH LATEST SMACNA STANDARDS.
- SCHEDULED MANUFACTURERS ARE BASIS OF DESIGN. SEE SPECIFICATIONS FOR OTHER ACCEPTABLE MANUFACTURERS.
- MAJOR EQUIPMENT SHOWN ON THE PLANS AND ELEVATIONS ILLUSTRATE THE GENERAL ARRANGEMENT AND SPACE ALLOCATION. VERIFY THE SPACE REQUIREMENTS FOR EACH SYSTEM COMPONENT USING MANUFACTURER CERTIFIED SHOP DRAWINGS AND MAKE THE NECESSARY ADJUSTMENTS IN EQUIPMENT PLACEMENT AND CONNECTIONS IN ORDER TO ACCOMMODATE THE EXACT EQUIPMENT TO BE INSTALLED IN COORDINATION WITH ARCHITECTURAL SPACES.
- REFER TO SPECIFICATIONS FOR SUPPORTS, ANCHOR BOLTS AND HANGERS FOR ALL EQUIPMENT. OTHER MISCELLANEOUS STEEL BRACING, SUPPORTS, AND REINFORCING STEEL REQUIRED TO SUPPORT EQUIPMENT SHALL BE FURNISHED AS PART OF THE SCOPE OF WORK OF DIVISION 23.
- ALL WORK SHALL BE PERFORMED IN ACCORDANCE WITH ALL APPLICABLE CODES, STANDARDS AND AUTHORITIES HAVING JURISDICTION.
- FLEX DUCTS ARE SAME SIZE AS DIFFUSER NECK.
- SEAL ALL PENETRATIONS OF FLOORS, SMOKE WALLS, FIRE WALLS, AND EXTERIOR WALLS.
- DO NOT RUN DUCT OR PIPE OVER ELECTRICAL PANELS COORDINATE LOCATION OF DUCTS AND EQUIPMENT IN MECHANICAL ROOMS WITH THE ELECTRICAL AND PLUMBING CONTRACTOR BEFORE ANY INSTALLATION.
- ALL DUCT RUN-OUTS TO SUPPLY AND EXHAUST, DIFFUSERS AND REGISTERS, SHALL HAVE MANUAL BALANCING DAMPERS. PROVIDE YOUNG REGULATORS WITH REMOTE ADJUSTMENT WHERE ABOVE CEILING IS INACCESSIBLE.
- SECURE ALL PERMITS AND PROVIDE ANY REQUIRED TEMPORARY UTILITIES.
- ALL FLEXIBLE DUCT SHALL BE UL 181, CLASS 1 AIR DUCT BLACK LINER, MAXIMUM LENGTH OF FLEXIBLE DUCT SHALL NOT EXCEED 6'-0". PROVIDE RIGID ROUND INSULATED AIR DUCT RUNOUT AS REQUIRED. FLEXIBLE DUCT SHALL HAVE THE EQUIVALENT OF ONLY TWO 90 DEG. ELBOWS MAXIMUM. FLEX DUCTS ARE SAME SIZE AS DIFFUSER NECK.
- THE AIR QUANTITIES SHOWN ON THE DRAWINGS FOR INDIVIDUAL OUTLETS MAY BE SHOWN TO OBTAIN UNIFORM TEMPERATURE WITHIN EACH ZONE, BUT THE TOTAL AIR QUANTITY CHANGED FOR EACH ZONE MUST BE OBTAINED.
- INSTALL SMOKE DETECTOR FOR ALL UNITS WITH CAPACITY OF 2200 CFM AND HIGHER AS REQUIRED BY CODE. FIRE ALARM CONTRACTOR TO FURNISH AND TERMINATE.
- ALL SUPPLY & RETURN AIR DUCTS LOCATED IN UNCONDITIONED ATTICS, OUTSIDE THE ENVELOPE OR OUTSIDE THE BUILDING SHALL BE INSULATED USING R-8 INSULATION. EXTERNALLY INSULATED DUCT SHALL BE R-8 (INSTALLED) OR MINIMUM REQUIRED BY CURRENT HOUSTON COMMERCIAL ENERGY CONSERVATION CODE.
- ALL SUPPLY AND RETURN DUCTS LOCATED IN A CONDITIONED SPACE OR INSIDE THE ENVELOPE SHALL BE INSULATED USING MINIMUM R-6 INSULATION (INSTALLED R-VALUE). EXTERNALLY INSULATED DUCT SHALL BE R-6 OR MINIMUM REQUIRED BY CURRENT ENERGY CONSERVATION CODE.
- PROVIDED RECORD DRAWINGS OF THE ACTUAL INSTALLATION TO THE BUILDING OWNER OR THE DESIGNATED REPRESENTATIVE OF THE BUILDING OWNER. RECORD DRAWINGS SHALL INCLUDE AS A MINIMUM THE LOCATION AND PERFORMANCE DATA ON EACH PIECE OF EQUIPMENT, GENERAL CONFIGURATION OF DUCT AND PIPE DISTRIBUTION SYSTEM INCLUDING SIZES, AND THE TERMINAL AIR OR WATER DESIGN FLOW RATES.
- PROVIDE OPERATING AND MAINTENANCE MANUALS TO THE BUILDING OWNER OR THE DESIGNATED REPRESENTATIVE OF THE BUILDING OWNER. THESE MANUALS SHALL BE IN ACCORDANCE WITH INDUSTRY-ACCEPTED STANDARDS, AND SHALL INCLUDE, AT A MINIMUM, THE FOLLOWING:
(A) SUBMITTAL DATA STATING EQUIPMENT SIZE AND SELECTED OPTIONS FOR EACH PIECE OF EQUIPMENT REQUIRING MAINTENANCE.
(B) OPERATION MANUALS AND MAINTENANCE MANUALS FOR EACH PIECE OF EQUIPMENT REQUIRING MAINTENANCE, EXCEPT EQUIPMENT NOT FURNISHED AS PART OF THE PROJECT. REQUIRED ROUTINE MAINTENANCE ACTIONS SHALL BE CLEARLY IDENTIFIED.
(C) NAMES AND ADDRESSES OF AT LEAST ONE SERVICE AGENCY.
(D) HVAC CONTROLS SYSTEM MAINTENANCE AND CALIBRATION INFORMATION, INCLUDING WIRING DIAGRAMS, SCHEMATICS, AND CONTROL SEQUENCE DESCRIPTIONS, DESIRED OR FIELD-DETERMINED SET-POINTS SHALL BE PERMANENTLY RECORDED ON CONTROL DRAWINGS AT CONTROL DEVICES OR, FOR DIGITAL CONTROL SYSTEMS, IN PROGRAMMING COMMENTS.
(E) A COMPLETE NARRATIVE OF HOW EACH SYSTEM IS INTENDED TO OPERATE, INCLUDING SUGGESTED SET-POINTS.
- DUCTWORK THAT IS DESIGNED TO OPERATE AT STATIC PRESSURES IN EXCESS OF 3 IN. W.C. SHALL BE LEAK TESTED ACCORDING TO INDUSTRY-ACCEPTED TEST PROCEDURES. REPRESENTATIVE SECTIONS TOTALING NO LESS THAN 25% OF THE TOTAL INSTALLED DUCT AREA FOR THE DESIGNATED PRESSURE CLASS SHALL BE TESTED. DUCT SYSTEMS WITH PRESSURE RATINGS IN EXCESS OF 3 IN. W.C. SHALL BE IDENTIFIED ON THE DRAWINGS. THE MAXIMUM PERMITTED DUCT LEAKAGE SHALL BE NO MORE THAN 1% OF THE TOTAL AIRFLOW IN THE SECTION TESTED OR AS REQUIRED BY CURRENT COMMERCIAL ENERGY CONSERVATION CODE.
- DUCTWORK AND PLENUMS SHALL BE SEALED IN ACCORDANCE WITH THE MECHANICAL CODE AND SMACNA METHOD AND COMMERCIAL ENERGY CONSERVATION CODE. SEAL ALL LONGITUDINAL AND TRAVERSE JOINTS.
- ALL HVAC SYSTEMS SHALL BE BALANCED IN ACCORDANCE WITH GENERALLY ACCEPTED ENGINEERING STANDARDS. A WRITTEN BALANCE REPORT SHALL BE PROVIDED TO THE OWNER OR THE DESIGNATED REPRESENTATIVE OF THE BUILDING OWNER.
- HVAC CONTROL SYSTEMS SHALL BE TESTED TO ENSURE THAT CONTROL ELEMENTS ARE CALIBRATED, ADJUSTED, AND PROPER WORKING CONDITION AS REQUIRED BY COMMERCIAL ENERGY CONSERVATION CODE.
- PROVIDE AND INSTALL CONTROL SYSTEM COMPATIBLE THERMOSTAT WHERE SHOWN. COORDINATE T-STAT LOCATION WITH LIGHT SWITCHES AND OTHER WALL MOUNTED DEVICES.
- PIPE INSULATION SHALL BE 1-1/2" IF THE PIPE DIAMETER IS LESS THAN OR EQUAL TO 1-1/2". IF THE PIPE DIAMETER IS LARGER THAN 1-1/2", PIPE INSULATION SHALL BE 2".

ISSUE #	DATE	DESCRIPTION
1	02/29/2016	100% CD

Infrastructure Associates
INFRASTRUCTURE ASSOCIATES, INC.
 617 RICHMOND AVENUE, SUITE 200
 HOUSTON, TEXAS 77057
 TYPE REGISTRATION NO. F-4506
 (713) 622-0120 PH (713) 622-0557 FAX
 WWW.IAHOUSTON.COM

bdg
architecture
+planning
 boucher design group

Boucher Design Group LLC
 Members A.I.A.
 6802 Maple Ridge, Suite 200
 Bellaire, Texas 77401
 Tel. 713.785.3644
 www.bdgap.com

This document is an instrument of service protected by the copyright law of the United States of America, 17 U.S.C §102, and shall not be copied or reproduced without the express written consent of Boucher Design Group, LLC. 2016

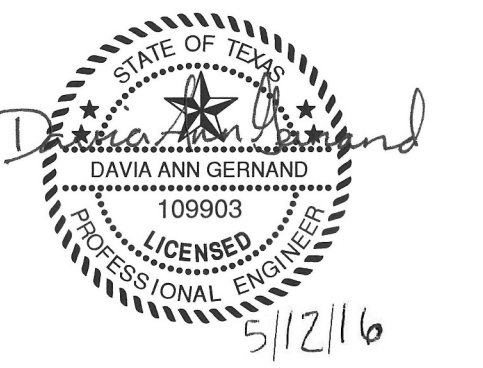

BAYSIDE COMMUNITY CENTER
 BA CLIFF, TEXAS
GALVESTON COUNTY

DATE: 02/29/16
 PROJECT NO.: 1409000
 DRAWN BY: OC/CJCT
 CHECKED BY: WJK/DG

NOTES AND LEGENDS

M101

AIR HANDLING UNIT/FAN COIL UNIT SCHEDULE (SPLIT-DX)																							
MARK	AIRFLOW (CFM)	OUTSIDE AIR FLOW (CFM)	LOCATION	CONFIGURATION	FAN		DIRECT EXPANSION COIL					ELECTRIC HEATER (KW)	IN-DOOR UNIT ELECTRICAL DATA			IN-DOOR UNIT MAKE AND MODEL	OUT-DOOR UNIT ELECTRICAL DATA					OUT-DOOR UNIT MAKE AND MODEL	REMARKS
					E.S.P. (IN. WG.)	MOTOR (HP)	MAX FACE VEL. (FPM)	TOT. CAPACITY (BTUH)	SEN. CAPACITY (BTUH)	EAT DB/WB (°F)	LAT DB/WB (°F)		MCA	MOCP	VOLTAGE		TONNAGE	AMBIENT (°F)	MCA	MOCP	VOLTAGE		
FCU-1 & CU-1	2,050	310	ABOVE CEILING	HORIZONTAL	0.75	1.5	500	81,350	51,400	78/65	55/54	19	32.4	35	480/3/60	CARRIER - 39S	7.5	105	17	25	480/3/60	CARRIER - 38AUZ	1,2,3,4,5,6,7,8,9,11,12
FCU-2 & CU-2	2,200	260	ABOVE CEILING	HORIZONTAL	0.75	1.0	500	67,720	58,140	77/64	55/54	21	34.8	35	480/3/60	CARRIER - 39S	6.0	105	12	20	480/3/60	CARRIER - 38AUZ	1,2,3,4,5,6,7,8,9,11,12
AHU-1A & AHCU-1A	3,100	500	MECH. I2	VERTICAL	1.5	5.0	500	103,290	79,030	77/64	55/54	29	44.0	45	480/3/60	CARRIER - 39M	10.0	105	19	25	480/3/60	CARRIER - 38AUD	2,3,4,5,6,7,8,11,12
AHU-1B & AHCU-1B	4,675	615	MECH. I2	VERTICAL	1.5	5.0	500	131,030	112,360	77/64	55/54	44	66.0	70	480/3/60	CARRIER - 39M	12.5	105	26	30	480/3/60	CARRIER - 38AUD012	2,3,4,5,6,7,8,11,12

NOTES:

- INSTALL AUXILIARY DRAIN PAN UNDER UNIT.
- PROVIDE MERV-8 (2") DEEP FLAT FILTER WITH THE UNIT.
- PROVIDE MATCHING CONDENSING UNIT AS INDICATED.
- PROVIDE IN-DOOR UNIT WITH SINGLE POINT POWER CONNECTION.
- INSTALL WATER SENSING DEVICE IN PRIMARY DRAIN PAN TO SHUT UNIT DOWN WHEN WATER SENSED IN THE PAN.
- UNIT EER MUST COMPLY WITH LATEST IEC REQUIREMENTS.
- MANUFACTURERS SHALL CONFIRM ALL REFRIGERANT LINES, SIZES INDICATED AND SUBMIT A PART OF EQUIPMENT SUBMITTAL.
- UNITS REFRIGERANT SHALL BE R-410A.
- PROVIDE UNIT WITH 4 ISOLATORS AND SUPPORTS FOR SUSPENDING UNIT FROM STRUCTURE.
- PROVIDE UNIT WITH DOUBLE WALL CONSTRUCTION.
- PROVIDE UNIT WITH RAWAL VALVE.
- PROVIDE EVAPORATOR AND CONDENSER COILS WITH COATING ABLE TO WITHSTAND COASTAL WEATHER.
- PROVIDE VARIABLE FREQUENCY DRIVE FOR INDOOR OUTDOOR AIR UNIT.

EXHAUST FAN SCHEDULE												
PLAN MARK	SERVING	AIR VOLUME (CFM)	FAN TYPE	DRIVE TYPE	E.S.P. INCH W.G.	FAN SPEED (RPM)	MOTOR			MANUFACTURER & MODEL	LOCATION	REMARKS
							HP	V/P/Hz	RPM			
EF-1	BATHROOMS	600	DOWN-BLAST	INLINE	0.25	705	1/2	115/11/60	705	GREENHECK	WALL MOUNTED	1, 2, 3, 4
EF-2	JANITOR	100	DOWN-BLAST	INLINE	0.25	705	1/2	115/11/60	705	GREENHECK	WALL MOUNTED	1, 2, 3, 4

NOTES:

- FAN SHALL BE SUITABLE FOR OUTDOOR INSTALLATION AND OPERATION.
- MANUFACTURER'S SUPPLIED 14" HIGH ROOF CURB AND BIRD SCREEN.
- PROVIDE MOTORIZED DAMPER FOR UNIT WITH 300+ CFM. PROVIDE BACK-DRAFT DAMPER ON UNITS WITH LESS THAN 300 CFM. MOTORIZED DAMPER SHALL CLOSE WHEN ASSOCIATED FAN IS DE-ENERGIZED.
- PROVIDE ECM MOTOR WITH DIAL ON MOTOR.

DIFFUSER NECK-DUCT SIZE SCHEDULE	
SUPPLY AIR (CFM)	DIFFUSER NECK AND BRANCH DUCT SIZE
0 - 100	6"Ø
101 - 200	8"Ø
201 - 300	10"Ø
301 - 400	12"Ø
401 - 500	14"Ø

AIR OUTLET SCHEDULE									
PLAN MARK	MAKE	TYPE	MODEL	FACE SIZE	NECK/DUCT SIZE	MATERIAL	FINISH	MOUNTING	REMARKS
(A)	TITUS	SUPPLY	OMNI-AA	24X24	SEE NECK SCHEDULE	ALUMINUM	STEEL	REFER TO PLANS	1, 2, 3, 4, 5
(B)	TITUS	RETURN	50F	24x24	SEE NECK SCHEDULE	ALUMINUM	STEEL	CEILING	1, 2, 3, 4, 5
(C)	TITUS	EXHAUST	US30I	REF. PLANS	SEE NECK SCHEDULE	ALUMINUM	STEEL	CEILING	1, 2, 3, 4, 5
(D)	TITUS	RETURN	272 FL	REF. PLANS	REFER TO PLANS	ALUMINUM	STEEL	WALL	1, 2, 3, 4, 5

NOTES:

- PROVIDE ROUND NECK ADAPTER FOR ALL SUPPLY, RETURN, AND EXHAUST AIR DIFFUSERS WHERE NECESSARY.
- REFER TO PLANS FOR AIR FLOW RATE.
- REFER TO DIFFUSER NECK-DUCT SIZE SCHEDULE FOR TAKE OFF BRANCH SIZES.
- ARCHITECT TO SELECT FINISH FROM MANUFACTURER'S STANDARD COLORS FOR DIFFUSERS/GRILLES.
- SEE DIFFUSER NECK-DUCT SIZE SCHEDULE UNLESS OTHERWISE SPECIFIED ON PLANS.

ISSUE #	DATE	DESCRIPTION
1	02/29/2016	100% CD
2	05/12/2016	VE Changes



Boucher Design Group LLC
Members A.I.A.
6802 Mapleridge, Suite 200
Bellaire, Texas 77401
Tel. 713.785.3644
www.bdgap.com

This document is an instrument of service protected by the copyright law of the United States of America, 17 U.S.C §102, and shall not be copied or reproduced without the express written consent of Boucher Design Group, LLC. 2016



BAYSIDE COMMUNITY CENTER	
BACLIFF, TEXAS	
GALVESTON COUNTY	
DATE	02/29/16
PROJECT NO.	1409000
DRAWN BY	OC/CJCT
CHECKED BY	WJK/DG

SCHEDULES

M102

ISSUE #	DATE	DESCRIPTION
0	02/29/2016	100% CD
1	05/12/2016	VE Changes

Infrastructure Associates
 INFRASTRUCTURE ASSOCIATES, INC.
 617 RICHMOND AVENUE, SUITE 200
 HOUSTON, TEXAS 77002
 TFP# REGISTRATION NO. F-4566
 (713) 622-0210 PH (713) 622-0557 FAX
 WWW.IAHOUSTON.COM

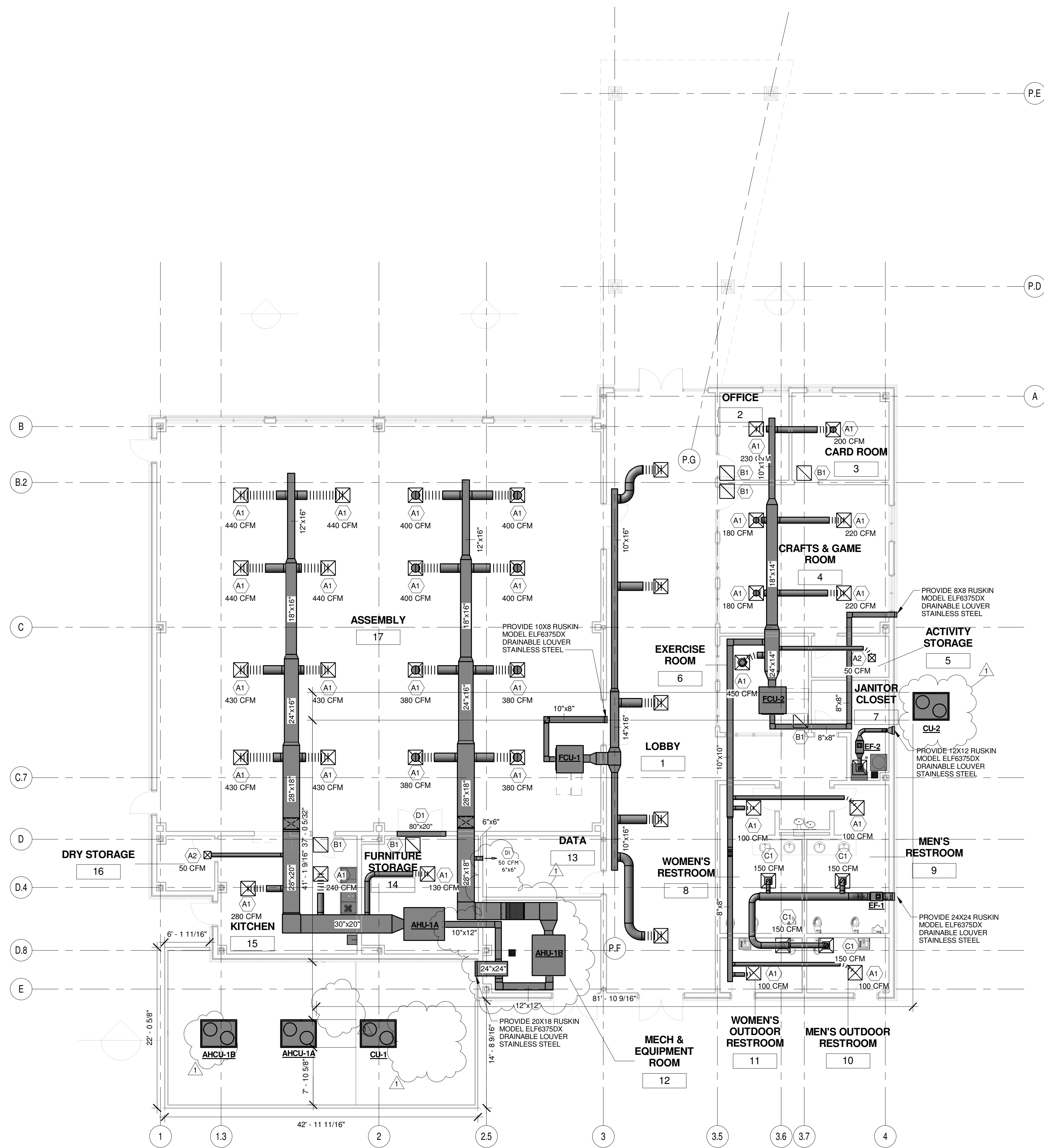

1 HVAC FLOOR PLAN
 1/8" = 1'-0"



Boucher Design Group LLC
 Members A.I.A.
 6802 Mapleridge, Suite 200
 Bellaire, Texas 77401
 Tel. 713.785.3644
 www.bdgap.com

This document is an instrument of service protected by the copyright law of the United States of America, 17 U.S.C §102, and shall not be copied or reproduced without the express written consent of Boucher Design Group, LLC. 2016

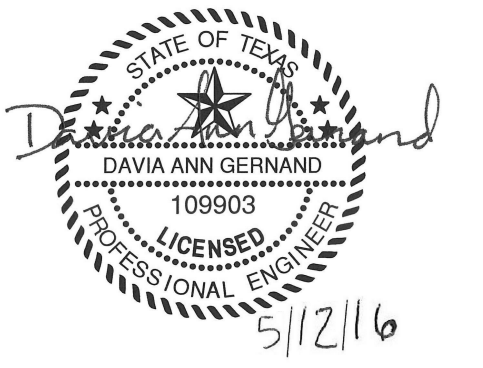

BAYSIDE COMMUNITY CENTER
 BA CLIFF, TEXAS
 GALVESTON COUNTY

DATE	02/29/16
PROJECT NO.	1409000
DRAWN BY	OC/CT
CHECKED BY	WJK/DG

HVAC FLOOR PLAN

M201
 © COPYRIGHT 2016 BOUCHER DESIGN GROUP, LLC

ISSUE #	DATE	DESCRIPTION
1	02/29/2016	100% CD



INFRASTRUCTURE ASSOCIATES, INC.
617 RICHMOND AVENUE, SUITE 200
HOUSTON, TEXAS 77057
TELE REGISTRATION NO. F-4506
(713) 622-0120 PH (713) 622-0557 FAX
WWW.IAHOUSTON.COM



Boucher Design Group LLC
Members A.I.A.
8802 Maple Ridge, Suite 200
Bellaire, Texas 77401
Tel. 713.785.3644
www.bdgap.com

This document is an instrument of service protected by the copyright law of the United States of America, 17 U.S.C §102, and shall not be copied or reproduced without the express written consent of Boucher Design Group, LLC. 2016



BAYSIDE COMMUNITY CENTER
BACLIFF, TEXAS
GALVESTON COUNTY

DATE	02/29/16
PROJECT NO.	1409000
DRAWN BY	OC/CJCT
CHECKED BY	WJK/DG

DETAILS

M301

<p>NOTE: SEE FLOOR PLANS FOR DIMENSIONS</p>	<p>NOTE: FASTEN DUCT TO SLEEVE WITH "S" SLIP ON TOP & BOTTOM & DRIVE SLIP ON SIDES</p>	
<p>DUCTWORK FITTINGS DETAIL</p>	<p>DUCT PENETRATION THROUGH FIRE RATED WALL</p>	<p>REFRIGERANT PIPING DETAIL</p>
<p>NOT TO SCALE 6</p>	<p>NOT TO SCALE 4</p>	<p>NOT TO SCALE 2</p>
<p>NOTES: 1. PROVIDE MOTORIZED DAMPER FOR UNITS WITH 300+CFM AND BACK-DRAFT DAMPER FOR ALL OTHERS. DAMPER TO CLOSE WHEN UNIT IS NOT IN OPERATION. 2. DAMPERS LEAKAGE SHALL NOT EXCEED 0.3 CFM/SF.</p>	<p>NOTE: 1. REFER TO AIR DEVICE SCHEDULE ON DRAWINGS FOR ADDITIONAL REQUIREMENTS.</p>	<p>NOTE: THE FLANGED BELLMOUTH FITTING MUST BE PROVIDED, WHERE HEIGHT OF DUCT SHOWN ON PLANS CAN ACCOMMODATE THE FITTING. ONLY WHERE THE DUCT HEIGHT DOES NOT ALLOW THE INSTALLATION OF BELLMOUTH FITTING, PROVIDE STRAIGHT FITTING. FLEX DUCT MAY BE LOCATED IN RISER OR HORIZONTAL RUN.</p>
<p>POWER ROOF VENTILATOR DETAIL</p>	<p>RETURN AIR GRILLE WITH BOOT DETAIL</p>	<p>CEILING DIFFUSER CONNECTION DETAIL</p>
<p>NOT TO SCALE 5</p>	<p>NOT TO SCALE 3</p>	<p>NOT TO SCALE 1</p>

ISSUE #	DATE	DESCRIPTION
1	02/29/2016	100% CD



Boucher Design Group LLC
Members A.I.A.
8802 Maple Ridge, Suite 200
Bellaire, Texas 77401
Tel. 713.785.3644
www.bdgap.com

This document is an instrument of service protected by the copyright law of the United States of America, 17 U.S.C. § 102, and shall not be copied or reproduced without the express written consent of Boucher Design Group, LLC. 2016



BAYSIDE COMMUNITY CENTER
BACLIFF, TEXAS
GALVESTON COUNTY

DATE	02/29/16
PROJECT NO.	1409000
DRAWN BY	OC/CJCT
CHECKED BY	WJK/DG

SYMBOL LEGEND

E101

ELECTRICAL SYMBOL LEGEND				
SYMBOL	DESCRIPTION	SYMBOL	DESCRIPTION	ABBREVIATION DEFINITIONS
	HOME RUN TO PANEL HA. CIRCUITS 1, 3, 5 USING 3#12 (N), 3#12 (G), #12 (S). 3/4" C (UNLESS OTHERWISE NOTED) EACH CIRCUIT WILL HAVE ITS OWN NEUTRAL		LIGHTING CLASS PANEL HA = PANEL NAME CHARACTERISTICS AS INDICATED ON ONE LINE DIAGRAM AND PANEL SCHEDULE	2SIW TWO-SPEED, ONE-WINDING MOTOR
	ROUND INCANDESCENT, HID, OR COMPACT FLUORESCENT LUMINAIRE RECESSED OR SUSPENDED FROM ABOVE XX = TYPE ON LUMINAIRE SCHEDULE		DISTRIBUTION CLASS PANEL DA = PANEL NAME CHARACTERISTICS AS INDICATED ON ONE LINE DIAGRAM	2S2W TWO-SPEED, TWO-WINDING MOTOR
	ROUND INCANDESCENT, HID, OR COMPACT FLUORESCENT LUMINAIRE SUSPENDED FROM SIDE ARM XX = TYPE ON LUMINAIRE SCHEDULE		CONDUIT TURNING UP CONDUIT TURNING DOWN	(A) ABANDONED TO REMOVE
	LINEAR FLUORESCENT LUMINAIRE RECESSED OR SUSPENDED FROM ABOVE XX = TYPE ON LUMINAIRE SCHEDULE		WEATHER HEAD FOR CONNECTING OVER HEAD CONDUCTORS	A PHASE "A" IN THREE-PHASE SYSTEM
	LINEAR FLUORESCENT WITH EMERGENCY EGRESS OPERATION RECESSED OR SUSPENDED FROM ABOVE XX = TYPE ON LUMINAIRE SCHEDULE		20" CU CHATWORTH GROUNDING BUSBAR 40153-020 TMGB PATTERN, 4" W x 1/4" H, 20" L, INSULATED STANDOFFS, PRE-DRILLED & TAP AS REQUIRED FOR CONDUCTORS	A AMPERES
	EXIT SIGN WITH DIRECTIONAL ARROWS AS INDICATED, 1 OR 2 FACE PENDANT MOUNTED FROM ABOVE XI OR X2 = TYPE ON LUMINAIRE SCHEDULE		FIRE ALARM MANUAL PULL STATION WITH TAMPER COVER	AF AMPERE FUSE OR FRAME RATING
	EMERGENCY EGRESS ONLY LUMINAIRE SURFACE MOUNTED FROM BACK XX = TYPE ON LUMINAIRE SCHEDULE		FIRE ALARM SMOKE DETECTOR, CEILING MOUNTED	AFCI ARC FAULT CIRCUIT INTERRUPTER
	NEMA 5-20R DUPLEX RECEPTACLE, MOUNTED 18" AFF (UON) WP = WEATHER PROOF, GFI = GFCI PROTECTED, IG = ISOLATED GROUND PROVIDE WITH STAINLESS STEEL COVERPLATE AND CIRCUIT NUMBER		FIRE ALARM HEAT DETECTOR, CEILING MOUNTED	AFF ABOVE FINISHED FLOOR
	NEMA 5-20R QUADRAPLEX RECEPTACLE, MOUNTED 18" AFF (UON) WP = WEATHER PROOF, GFI = GFCI PROTECTED, IG = ISOLATED GROUND PROVIDE WITH STAINLESS STEEL COVERPLATE AND CIRCUIT NUMBER		FIRE ALARM DUCT-MOUNTED SMOKE DETECTOR	AT AMPERE TRIP SETTING
	SIMPLEX RECEPTACLE, MOUNTED 18" AFF (UON) WITH INDICATED CONFIGURATION (E.G. L6-30R = NEMA TWISTLOCK, 250 VAC, 30 A)		FIRE ALARM SUPERVISORY SHUTDOWN RELAY	AFG ABOVE FINISHED GRADE
	FLUSH FLOOR BOX WITH WIRING DEVICES AS INDICATED ON PLANS		FIRE ALARM FIRE-WATER FLOW SWITCH	B PHASE "B" IN THREE-PHASE SYSTEM
	JUNCTION BOX		FIRE ALARM FIRE-WATER TAMPER SWITCH	BF BALLAST FACTOR
	LIGHT SWITCH RATED 120/277 VAC, MOUNTED 42" AFF (UON), SINGLE-POLE (UON) 2 = 2-POLE, 3 = 3-WAY, 4 = 4-WAY, D = DIMMER, M = MOTOR-RATED W/ OL, WP = WEATHER PROOF, OS = INTEGRAL OCCUPANCY SENSOR, R = RED COLOR, K = KEYPAD (MODIFIERS MAY BE COMBINED, E.G. D3 = 3-WAY DIMMER)		FIRE ALARM AUDIO/VISUAL HORN/STROBE	BFC BELOW FINISHED CEILING
	CEILING OR WALL MOUNTED OCCUPANCY SENSOR LIGHTING CONTROL WITH PASSIVE INFRARED AND ULTRASOUND DUAL TECHNOLOGY, 20 A RATED		FIRE ALARM VISUAL STROBE	BFF BELOW FINISHED FLOOR
	TV OUTLET 1-GANG BACKBOX, +42" AFF (UON), SS-302 COVER 1" C WITH MEASURED PULL STRING ROUTED IN CONDUITS BACK TO SERVER ROOM DEVICES AND LOW-VOLTAGE CABLING BY TELECOM CONTRACTOR		FIRE ALARM SPEAKER	BFG BELOW FINISHED GRADE
	WALL TELEPHONE OUTLET 1-GANG BACKBOX, +42" AFF (UON), SS-302 COVER 1" C WITH MEASURED PULL STRING ROUTED IN CONDUITS BACK TO SERVER ROOM DEVICES AND LOW-VOLTAGE CABLING BY TELECOM CONTRACTOR		FIRE ALARM CONTROL PANEL	C PHASE "C" IN THREE-PHASE SYSTEM
	COMBINATION DATA/VOICE (CAT 6E CABLE) OUTLET 2-GANG BACKBOX, SS-302 COVER 1" C WITH MEASURED PULL STRING ROUTED IN CONDUITS BACK TO SERVER ROOM. DEVICES AND LOW-VOLTAGE CABLING BY TELECOM CONTRACTOR. XX - DENOTES NUMBER OF CAT6 CABLES		FIRE ALARM REMOTE ANNUNCIATOR PANEL	C CONDUIT
	MULTIOUTLET ASSEMBLY (PLUG MOLD) AS SPECIFIED ON PLANS, WITH DEVICE TYPES AND QUANTITIES INDICATED ON PLANS		PUBLIC ADDRESS SPEAKER, CEILING-MOUNTED WALL-MOUNTED VOLUME CONTROL ADJACENT TO LIGHT SWITCH (UON)	CB CIRCUIT BREAKER
	EMERGENCY POWER OFF, MUSHROOM HEAD, MAINTAINED CONTACT PUSH BUTTON		PUBLIC ADDRESS SPEAKER, CEILING-MOUNTED	CH CONSTANT HORSE POWER (2SIW MOTOR)
	PHOTOELECTRIC SENSOR AIMED NORTH		PUBLIC ADDRESS INTERCOM CALL BUTTON, WALL-MOUNTED 42" AFF	CKT CIRCUIT
	TIME CLOCK, ASTRONOMIC/MULTI-POLE CONTACTOR		INTRUSION ALARM MOTION DETECTOR	CS COMBINATION STARTER (MOTOR STARTER / DISCONNECT)
	POWER COMPANY POWER METER		INTRUSION ALARM NUMERIC KEY-PAD	CT CONSTANT TORQUE (2SIW MOTOR)
	LIGHTING CONTACTOR CHA = CONTACTOR NAME, COIL = COIL CONTROL VOLTAGE, VAC = VOLTAGE RATING, AS = CURRENT RATINGS, P = POLE COUNT, NEMA- = ENCLOSURE TYPE		INTRUSION ALARM DOOR CONTACTOR	CT CURRENT TRANSFORMER
	CIRCUIT BREAKER VAC = VOLTAGE RATING, AF = FRAME SIZE, AT = TRIP SETTING, P = POLE COUNT, NEMA- = ENCLOSURE TYPE (WHEN APPLICABLE) MOLDED-CASE, THERMO-MAGNETIC (UON)		ACCESS CONTROL CARD READER	(D) EXISTING TO BE DEMOLISHED OR REMOVED
	DISCONNECT SWITCH VAC = VOLTAGE RATING, AS = SWITCH CURRENT RATING, AF = FUSE SIZE/TYPER (E.G. DETD), P = POLE COUNT, NEMA- = ENCLOSURE TYPE (WHEN APPLICABLE)		ACCESS CONTROL MAGNETIC DOOR LOCK	DETD DUAL ELEMENT, TIME DELAY
	COMBINATION CIRCUIT BREAKER, MOTOR CONTROLLER, AND THERMAL OVERLOAD VAC = VOLTAGE RATING, AF = FRAME SIZE, AT = TRIP SETTING, NEMA-# = MOTOR STARTER SIZE/TYPER (E.G. FVNR), HOA = SELECTOR SWITCH TYPE P = POLE COUNT, NEMA- = ENCLOSURE TYPE (WHEN APPLICABLE)		ACCESS CONTROL DOOR HOLD-OPEN	DS DISCONNECT SWITCH
			VARIABLE FREQUENCY DRIVE WITH INTEGRAL DISCONNECTING MEANS, VFCl	(E) EXISTING TO REMAIN
			MOTOR, SINGLE OR THREE PHASE HP = HORSE POWER	EHT ELECTRICAL METALLIC TUBING
			EQUIPMENT CONNECTION	EFM ELECTRONIC POWER METER
				FAAP FIRE ALARM ANNUNCIATOR PANEL
				FACP FIRE ALARM CONTROL PANEL
				FVNR FULL VOLTAGE NON-REVERSING GROUND
				GEC GROUNDING ELECTRODE CONDUCTOR
				GFI GROUND FAULT CIRCUIT INTERRUPTER
				HMT HARMONIC-MITIGATING TRANSFORMER
				HOA HAND / OFF / AUTO SWITCH (FOR FVNR OR 2SIW CONTACTOR)
				HLOA HIGH / LOW / OFF / AUTO (FOR 2SIW OR 2S2W CONTACTOR)
				IG ISOLATED GROUND
				JJR JAMMING RATIO
				KAIC KILO AMPERE INTERRUPTING CAPACITY
				KCMIL KILO CIRCULAR MILS
				kVA KILO VOLT AMPERES COMPLEX OR APPARENT POWER
				kVAR KILO VOLT AMPERES REACTIVE POWER
				kW KILO WATT REAL POWER
				L1 HOT LEG 1 IN SINGLE-PHASE SYSTEM < 250 VAC
				L2 HOT LEG 2 IN SINGLE-PHASE SYSTEM < 250 VAC
				LS+G LONG TERM, SHORT TERM, INSTANTANEOUS, AND GROUND-FAULT
				MCB MAIN CIRCUIT BREAKER
				MCC MOTOR CONTROL CENTER
				MLO MAIN LUGS ONLY
				(N) NEW
				N NEUTRAL
				NEC NATIONAL ELECTRICAL CODE (NFPA 70)
				NEMA NATIONAL ELECTRICAL MANUFACTURERS ASSOCIATION
				NF NON-FUSIBLE
				NFFA NATIONAL FIRE PROTECTION ASSOCIATION
				NSL NON-SWITCHED HOT LEG
				OFCl OWNER FURNISHED, CONTRACTOR INSTALLED
				OS OCCUPANCY SENSOR
				P POLES
				PF POWER FACTOR
				PFCC POWER FACTOR CORRECTION CAPACITOR
				PVC POLY VINYL CHLORIDE
				PT POTENTIAL TRANSFORMER
				RAL RIGID ALUMINUM
				RGS RIGID GALVANIZED STEEL
				SEC SECTION OF LIGHTING-CLASS PANEL
				SPD SURGE PROTECTION DEVICE
				SS-xxx STAINLESS STEEL, "xxx" = AUSTENITIC ALLOY TYPE (E.G. 304)
				ST SHUNT-TRIP FOR CIRCUIT BREAKER
				THD TOTAL HARMONIC DISTORTION
				TVSS TRANSIENT VOLTAGE SURGE SUPPRESSION
				TYP TYPICAL
				UNLESS OTHERWISE NOTED
				V VOLTS
				VAC VOLTS, ALTERNATING CURRENT
				VDC VOLTS, DIRECT CURRENT
				VFCI VENDOR FURNISHED, CONTRACTOR INSTALLED
				VFD VARIABLE FREQUENCY DRIVE
				VT VARIABLE TORQUE (2SIW MOTOR)
				W WIRES, NOT INCLUDING GEC
				WP WEATHER PROOF
				# AMERICAN WIRE GAGE
				Ø PHASE
				M F MICRO FARAD
				W OHMS

- GENERAL NOTES:**
1. SYMBOL LEGEND MAY CONTAIN SYMBOLS THAT ARE NOT USED ON ALL DRAWINGS.
 2. ABBREVIATION DEFINITIONS ARE NOT COMPREHENSIVE, AND NOT ALL ABBREVIATIONS MAY APPLY TO ALL DRAWINGS. SUBMIT FORMAL REQUEST FOR INFORMATION WHEN ENCOUNTERING CONFLICTS OR AMBIGUOUS SYMBOLS OR ABBREVIATIONS, AS THESE WILL NOT CONSTITUTE DISMISSAL OF CONTRACTOR RESPONSIBILITY.
 3. ALL COVER PLATES FOR RECEPTACLES, SWITCHES, AND DATA SHALL BE SS-302 (UON).
 4. PROVIDE DECORA STYLE SWITCHES FOR LIGHT SWITCHES THAT ARE NOT OCCUPANCY SENSOR TYPE.

LUMINAIRE SCHEDULE							GALVESTON COMMUNITY CENTER	
TYPE	DESCRIPTION	LAMPS	VOLT	WATTS	MOUNTING	MANUFACTURERS		
A/ AE	2'x4' LED FIXTURE, GRID RECESSED. TYPE 'AE' SAME AS 'A' EXCEPT PROVIDE WITH EMERGENCY BATTERY PACK CAPABLE OF PROVIDING 1400 LUMENS FOR A MINIMUM OF 90 MINUTES.	LED	MVOLT	42	RECESSED	COLUMBIA LIGHTING #LSER24-35VLG-C-EDU(ELL14)		
A2/ A2E	2'x4' LED FIXTURE, GRID RECESSED. TYPE 'A2E' SAME AS 'A2' EXCEPT PROVIDE WITH EMERGENCY BATTERY PACK CAPABLE OF PROVIDING 1400 LUMENS FOR A MINIMUM OF 90 MINUTES.	LED	MVOLT	82	RECESSED	COLUMBIA LIGHTING #LSER24-35VLG-C-EDU(ELL14)		
B	4' LED STRIP FIXTURE WITH WIREGUARD AND CHAIN HANGERS.	LED	MVOLT	43	SUSPENDED	BEGHELLI USA #BX910LEDH4T50WWT50-120-277		
C	6" HIGH EFFICACY LED OPEN DOWNLIGHT WITH 0-10V DIMMING CAPABILITY. TYPE 'CIE' SAME AS 'C' EXCEPT PROVIDE WITH EMERGENCY BATTERY PACK CAPABLE OF PROVIDING 1400 LUMENS FOR A MINIMUM OF 90 MINUTES.	LED	MVOLT	26	RECESSED	PRESCOLITE #LF6LEDG4/6LFLD7G435K		
C1/ C1E	6" HIGH EFFICACY LED OPEN DOWNLIGHT WITH 0-10V DIMMING CAPABILITY. TYPE 'C1E' SAME AS 'C1' EXCEPT PROVIDE WITH EMERGENCY BATTERY PACK CAPABLE OF PROVIDING 1400 LUMENS FOR A MINIMUM OF 90 MINUTES.	LED	MVOLT	15	RECESSED	PRESCOLITE #LF6LEDG4/6LFLD5G435K		
G/ GE	4' LED STRIP FIXTURE. TYPE 'CIE' SAME AS 'C' EXCEPT PROVIDE WITH EMERGENCY BATTERY PACK CAPABLE OF PROVIDING 1400 LUMENS FOR A MINIMUM OF 90 MINUTES.	LED	MVOLT	19	RECESSED	LUMENWERX #VIA3RF-HLO-LED-80-750-40-4 #UNV-D-1-OHC-W		
SA	LED POLE FIXTURE WITH TYPE 3 DISTRIBUTION ON A 18' POLE.	LED 4000K	MVOLT	110	POLE	BEACON #VP-S/48NB-110/4K/T3/UNV/RA/BZT SPAULDING #SSS-S-18-50-B-1-FINISH		
SB3	(3) LED POLE FIXTURE WITH TYPE 4 DISTRIBUTION ON A 18' POLE.	(3) LED 4000K	MVOLT	330	POLE	BEACON #VP-S/48NB-110/4K/T4/UNV/RA/BZT SPAULDING #SSS-S-18-50-B-2-FINISH		
SB4	(4) LED POLE FIXTURE WITH TYPE 4 DISTRIBUTION ON A 18' POLE.	(4) LED 4000K	MVOLT	440	POLE	BEACON #VP-S/48NB-110/4K/T4/UNV/RA/BZT SPAULDING #SSS-S-18-50-B-4-FINISH		
SC	SIDEWALK BOLLARD LED FIXTURE WITH 700mA DRIVER.	LED 4000K	MVOLT	33	POLE	HESS AMERICA #LN950-HP/LED-NW-UNV-D-033RAFINISH-N		
OA	4' LINEAR LED FIXTURE DESIGNED FOR HARSH ENVIRONMENTS.	LED 4000K	MVOLT	50	SURFACE	NEWSTAR #NSUN4-L2401-DA-UN-ST		
W/ WE	LED WALLPACK WITH TYPE 3 DISTRIBUTION WITH A MOUNTING HEIGHT OF 10' TYPE 'W' SAME AS 'W' EXCEPT PROVIDE WITH EMERGENCY BATTERY PACK CAPABLE OF PROVIDING 1400 LUMENS FOR A MINIMUM OF 90 MINUTES.	LED	MVOLT	55	WALL	BEACON #TRV-D/24NB-55/4K/T3/UNV/(BPC)/FINISH		
X1/ X2	LED EXIT SIGN WITH DIRECTIONAL ARROWS AND NUMBER OF FACES AS INDICATED ON PLANS. X1 = SINGLE FACE, X2 = DOUBLE FACE.	LED	MVOLT	5	WALL	DUAL-LITE #LECRXNEI		

- GENERAL NOTES:**
- ALL ELECTRONIC BALLASTS REQUIRE MINIMUM PF > 0.98 AND MAXIMUM THD < 10% AND SHALL BE PROGRAMMED RAPID START.
 - ALL FLUORESCENT LAMPS SHALL BE EXTENDED LIFE 40,000HRS. TYPE SUITABLE FOR PROGRAMMED RAPID START (E.G. XPS SERIES T8).
 - FB- FLUORESCENT T8 BALLAST- OSRAM SYLVANIA GTF (1/2)X3X32T8/UNV ISN-SC PSN T8 ELECTRONIC, PROGRAM START, LBF, THD < 10%.
 - EMERGENCY EGRESS OPERATION IN FLUORESCENT FIXTURES SHALL PROVIDE MINIMUM 1400 LUMENS FOR MINIMUM 90 MINUTES AND SHALL HAVE INTEGRAL TESTING AND CHARGING CIRCUIT WITH INDICATOR LIGHT. REMOTE INDICATOR LIGHT AND TESTING SWITCH IS NOT ACCEPTABLE. PROVIDE FIXTURE WITH INTEGRAL CHARGE INDICATOR LIGHT AND TESTING SWITCH.
 - PROVIDE ADDITIONAL, NON-SWITCHED HOT CIRCUIT LEG TO FIXTURE FOR BATTERY CHARGING AND POWER-LOSS DETECTION FOR ALL EMERGENCY EGRESS OR EXIT SIGN FIXTURES AS PART OF BASE BID.
 - ALL OUTDOOR LIGHTING FIXTURES REQUIRE CORROSION-RESISTANT OPTION.
 - COORDINATE MOUNTING HEIGHT OF ALL FIXTURES WITH ARCHITECTURAL DRAWINGS.
 - REFER TO ARCHITECTURAL PLANS FOR GRID/FLANGE AREAS, PRIOR TO BIDDING OF LIGHT FIXTURES. ORDER CORRECT QUANTITY OF EACH VARIATION.
 - WITH ARCHITECTURAL/ENGINEER APPROVAL, EQUAL FIXTURES WILL BE CONSIDERED FROM THE FOLLOWING MANUFACTURERS: HE WILLIAMS, PHILLIPS (DAYBRITE), LITHONIA.

FIRE ALARM SEQUENCE OF OPERATION	
<p>A. DETECTION & ALARM</p> <p>WHEN A FIRE ALARM CONDITION IS DETECTED BY ANY ALARM INITIATING DEVICE (SMOKE DETECTOR, DUCT DETECTOR, PULL STATION, OR SPRINKLER FLOW SWITCH), THE FOLLOWING FUNCTIONS WILL OCCUR:</p> <p>(a) THE FIRE ALARM CONTROL PANEL COMMON ALARM INDICATOR WILL FLASH AND THE AUDIBLE DEVICE WILL SOUND, ACKNOWLEDGING THE ALARM CONDITION WILL SILENCE THE AUDIBLE DEVICE AND CAUSE THE COMMON ALARM INDICATOR TO ILLUMINATE STEADILY.</p> <p>(b) THE DISPLAY WILL INDICATE ALL APPLICABLE INFORMATION ASSOCIATED WITH THE ALARM CONDITION INCLUDING ZONE, DEVICE TYPE, DEVICE LOCATION, AND TIME OF ALARM. LOCATION AND ZONING MESSAGES WILL BE CUSTOM FIELD PROGRAMMED TO MATCH THE RESPECTIVE PREMISES. LOCAL ANNUNCIATOR LED'S ASSOCIATED WITH THE ALARM POINT WILL FLASH UNTIL PANEL IS SILENCED.</p> <p>(c) DISPLAY SYSTEM STATUS CHANGES ON ANY REMOTE ANNUNCIATOR(S) VIA AN ALPHANUMERIC MESSAGE ON THE DISPLAY.</p> <p>(d) ACTIVATE AN ALARM CONTACT CLOSURE TO ACTIVATE A DIGITAL ALARM COMMUNICATOR TRANSMITTER (DACT) FOR SIGNALING TO A UL-APPROVED CENTRAL MONITORING STATION VIA TELEPHONE LINES FURNISHED BY OWNER.</p> <p>(e) ACTIVATE ALL AUDIO/VISUAL SIGNALS THROUGHOUT THE ENTIRE FACILITY.</p> <p>(f) ACTIVATE ALL VISUAL SIGNALS. VISUAL SIGNALS WILL BE HIGH INTENSITY STROBES (75 CPM) MINIMUM TO MEET THE REQUIREMENTS OF THE AMERICANS WITH DISABILITIES ACT (ADA) & TEXAS ACCESSIBILITY STANDARDS (TAS). ACTIVATE THROUGHOUT THE ENTIRE FACILITY. STROBES SHALL BE XENON TYPE AND WHITE OR CLEAR IN COLOR. THE MAX PULSE DURATION WILL BE 0.2 SECONDS WITH A MAXIMUM DUTY CYCLE OF 40%. THE FLASH RATE WILL BE BETWEEN 1-HZ AND 3-HZ.</p> <p>(g) DEACTIVATE ALL FANS RATED OVER 2,000 CFM.</p> <p>(h) ALARM VERIFICATION WILL BE FIELD-PROGRAMMABLE FOR EACH SMOKE DETECTOR. THE VERIFICATION SEQUENCE IS ACTIVATED AFTER A "CHECK" PROCEDURE AND THE PANEL WILL WAIT FOR A TIME THEN RESAMPLE THE DETECTOR FOR CONTINUED PRESENCE OF SMOKE. IF THE ALARM CONDITION CONTINUES OR A NON-VERIFIED DEVICE IS ACTUATED DURING THIS VERIFICATION PERIOD, THE PANEL WILL INITIATE ALL ALARM SEQUENCES. THIS ENTIRE SEQUENCE WILL OCCUR WITHIN 60 SEC. THE SYSTEM WILL LOG INTO MEMORY THE NUMBER OF VERIFICATION EVENTS.</p> <p>(i) CLOSE ALL SMOKE FIRE DAMPERS ASSOCIATED WITH THE HVAC UNIT(S).</p> <p>(j) ALL NON-SILENCEABLE AUXILIARY CONTROL FUNCTIONS (FANS, CENTRAL STATION INTERFACE, ELEVATOR RECALL INTERFACE, ETC) WILL REMAIN IN OPERATION, EVEN WHEN A/V DEVICES ARE SILENCED, UNTIL THE PANEL IS CLEARED AND RESET.</p>	<p>B. SYSTEM TROUBLE DETECTION</p> <p>WHEN A TROUBLE CONDITION IS DETECTED BY THE FIRE ALARM CONTROL PANEL, THE FOLLOWING FUNCTIONS SHALL OCCUR:</p> <p>(a) THE FIRE ALARM CONTROL PANEL TROUBLE INDICATOR WILL FLASH AND THE INTERNAL AUDIBLE DEVICE WILL SOUND, ACKNOWLEDGMENT OF THE AUDIBLE DEVICE WILL SILENCE THE AUDIBLE DEVICE AND CAUSE ALL TROUBLE INDICATORS TO ILLUMINATE STEADY.</p> <p>(b) THE DISPLAY WILL DISPLAY ALL APPLICABLE INFORMATION ASSOCIATED WITH THE RESPECTIVE TROUBLE CONDITIONS. LOCAL ANNUNCIATOR LED'S ASSOCIATED WITH THE ALARM POINT WILL ILLUMINATE.</p> <p>(c) ACTIVATE A TROUBLE CONTACT CLOSURE TO ACTIVATE A DACT FOR SIGNALING TO A UL-APPROVED CENTRAL MONITORING STATION VIA PHONE LINES FURNISHED BY OWNER.</p> <p>(d) DISPLAY THE SYSTEM STATUS CHANGES ON THE REMOTE ANNUNCIATOR(S) VIA AN ALPHANUMERIC MESSAGE ON THAT DISPLAY.</p> <p>C. SYSTEM SUPERVISORY ALARM DETECTION</p> <p>WHEN A SUPERVISORY ALARM CONDITION IS DETECTED DUE TO A FIRE SPRINKLER VALVE BEING PLACED IN AN "OFF-NORMAL" POSITION, THE FOLLOWING FUNCTIONS WILL OCCUR:</p> <p>(a) THE FIRE ALARM CONTROL PANEL SUPERVISORY INDICATOR WILL FLASH AND THE INTERNAL AUDIBLE DEVICE WILL SOUND, ACKNOWLEDGMENT OF THE SUPERVISORY CONDITION WILL SILENCE THE AUDIBLE DEVICE.</p> <p>(b) THE DISPLAY WILL DISPLAY ALL APPLICABLE INFORMATION ASSOCIATED WITH THE RESPECTIVE SUPERVISORY CONDITION. LOCAL ANNUNCIATOR LED'S WILL ILLUMINATE FOR THE ALARM POINT.</p> <p>(c) DISPLAY THE SYSTEM STATUS CHANGE ON THE REMOTE ANNUNCIATOR(S) VIA AN ALPHANUMERIC MESSAGE ON THAT DISPLAY.</p> <p>(d) ACTIVATE A SUPERVISORY ALARM CONTACT CLOSURE TO ACTIVATE THE DACT FOR SIGNALING TO A UL-APPROVED CENTRAL MONITORING STATION VIA PHONE LINES FURNISHED BY OWNER.</p> <p>D. FIRE ALARM PANEL</p> <p>FIRE ALARM PANEL SHALL BE INTELLIGENT DIGITAL PROTOCOL ANALOG ADDRESSABLE FIRE ALARM SYSTEM. THIS SYSTEM SHALL INCLUDE, BUT NOT BE LIMITED TO SYSTEM CABINET, POWER SUPPLY, BUILT SIGNALING LINE CIRCUIT (SLC), 80 CHARACTER LCD ANNUNCIATOR, SIX PROGRAMMABLE "FLEXPUT" CIRCUITS, BUILT IN DUAL LINE DIGITAL COMMUNICATOR ASSOCIATED PERIPHERAL DEVICES, BATTERIES, WIRING, CONDUIT AND OTHER RELEVANT COMPONENTS AND ACCESSORIES REQUIRED TO FURNISH A COMPLETE AND OPERATIONAL LIFE SAFETY SYSTEM. THE SYSTEM SHALL BE TESTED AFTER COMPLETION OF INSTALLATION IN ACCORDANCE WITH MANUFACTURE RECOMMENDED TESTING PROCEDURE AND GOVERNING LIFE SAFETY CODES.</p>

ELECTRICAL GENERAL NOTES AND SPECIFICATIONS

(BOOKS SPECIFICATIONS SUPERCEED ANY NOTES BELOW)

- SCOPE: THIS DIVISION SHALL INCLUDE ALL EQUIPMENT, MATERIALS, AND LABOR REQUIRED FOR COMPLETE INSTALLATION OF THE ELECTRICAL SYSTEM. PROJECT INCLUDES INSTALLATION OF NEW ELECTRICAL DISTRIBUTION SYSTEM, HVAC SYSTEM CONNECTIONS, NEW LIGHTING SYSTEM, NEW RECEPTACLES AND OUTLETS, FIRE ALARM AND NOTIFICATION SYSTEM, AND OTHER ELECTRICAL WORK AS INDICATED ON THE PLANS. CONTRACTOR SHALL PROVIDE CONDUITS, CONDUCTORS FOR POWER, CONTROLS, AND LIGHTING. LIGHTING CONTRACTOR AND CONTACT CLOSURES, AND ALL REQUIRED APPARATUS REQUIRED FOR FULL OPERATION OF THE ELECTRICAL SYSTEM.
- SITE VISIT AND FAMILIARIZATION: CONTRACTORS PROPOSING TO UNDERTAKE WORK UNDER THIS DIVISION SHALL VISIT THE SITE OF THE WORK, AND FULLY INFORM THEMSELVES OF ALL CONDITIONS THAT AFFECT THE WORK, OR COST THEREOF. CONTRACTOR SHALL EXAMINE THE DRAWINGS AND SPECIFICATIONS AS RELATED TO THE SITE CONDITIONS. ANY DISCREPANCY SHALL BE REPORTED TO THE ENGINEER.
- NOTICE: CONSIDERATION WILL NOT BE GRANTED FOR ANY ALLEGED MISUNDERSTANDING OF THE AMOUNT OF WORK TO BE PERFORMED. TENDER OF A PROPOSAL SHALL CONVEY FULL AGREEMENT TO ALL ITEMS AND CONDITIONS SPECIFIED, INDICATED ON THE DRAWINGS, AND/OR REQUIRED BY NATURE OF THE SITE.
- DISCREPANCIES: SHOULD CONTRACTOR FIND DISCREPANCIES OR OMISSIONS IN THE CONTRACT DOCUMENTS, OR BE IN DOUBT AS TO THE INTENT THEREOF, HE SHALL IMMEDIATELY OBTAIN CLARIFICATION FROM THE ARCHITECT BEFORE SUBMITTING PROPOSAL FOR WORK IN THIS DIVISION.
- DEMOLITION: ALL ELECTRICAL COMPONENTS OF THE EXISTING SYSTEM WHICH ARE NOT UTILIZED FOR NEW CONFIGURATION SHALL BE REMOVED AND DISPOSED OF BY CONTRACTOR. REFER TO DEMOLITION NOTES AND DRAWINGS FOR EXTENT OF WORK.
- TIMELY PLACING OF MATERIALS AND EQUIPMENT: ALL ELECTRICAL APPARATUS SHALL BE INSTALLED AT THE PROPER TIME DURING PROGRESS OF CONSTRUCTION. COORDINATE WORK OPERATIONS WITH OTHER TRADES.
- SPACE REQUIREMENTS: CONTRACTOR FOR WORK UNDER THIS DIVISION SHALL BE FULLY RESPONSIBLE FOR DETERMINING IN ADVANCE OF PURCHASE THAT EQUIPMENT AND MATERIALS PROPOSED FOR INSTALLATION SHALL FIT INTO THE CONFINES INDICATED. MANUFACTURER'S LITERATURE, DELIVER ALL PRINTED TAGS, INSTRUCTIONS, CERTIFIED DRAWINGS, PARTS LISTED, CERTIFICATES, ETC., SUPPLIED WITH EQUIPMENT ITEMS, TO THE OWNER.
- CODES, PERMITS, AND FEES: WORK UNDER THIS DIVISION SHALL BE CONSTRUCTED IN STRICT CONFORMANCE WITH PERTINENT PROVISIONS OF CITY AND STATE BUILDING CODES.
 - ALL WORK SHALL COMPLY WITH THE 2014 EDITION OF NATIONAL ELECTRIC CODE (NEC).
 - OBTAIN ALL REQUIRED PERMITS, PAY ALL LEGAL FEES FOR PERMITS AND INSPECTIONS BY AUTHORITIES HAVING JURISDICTION.
 - ALL WORK SHALL COMPLY WITH REQUIREMENTS OF CITY OF GALVESTON.
- CUTTING AND PATCHING:
 - CONTRACTOR FOR THIS DIVISION SHALL LAYOUT TO DIMENSION AND LOCATIONS, CUT AND PATCH ALL OPENINGS ON SURFACES TO BE FORMED, FRAMED, OR CUT.
 - SHOULD CONTRACTOR FOR THIS DIVISION FAIL TO ADHERE WITH THIS REQUIREMENT, AS WORK PROGRESSES, ANY OPENINGS SHALL BE CUT AND PATCHED BY GENERAL CONTRACTOR AT THE EXPENSE OF THIS CONTRACTOR FOR THIS DIVISION.
- PROTECTION OF APPARATUS: TAKE ALL PRECAUTIONS NECESSARY FOR PROPER PROTECTION OF NEW EQUIPMENT, APPARATUS, AND MATERIALS FROM DAMAGE. FAILURE TO DO SO WILL BE CAUSE FOR ANY ITEM COMING UNDER QUESTION.
- SHOP DRAWINGS: CONTRACTOR FOR THIS DIVISION SHALL SUBMIT SHOP DRAWINGS AND CATALOGUE DATA ON ALL MAJOR ITEMS OF EQUIPMENT AND SYSTEMS AND OTHER MATERIAL REQUESTED BY ARCHITECT/ENGINEER. SUBMIT PRODUCT DATA FOR SWITCHBOARDS, PANELBOARDS, TRANSFORMERS, WIRES, CABLE, SUPPORTING DEVICES, IDENTIFICATION COMPONENTS, LIGHT FIXTURES, FIRE ALARM SYSTEM AND COMPONENTS, WIRING DEVICES, MULTI-OUTLET RECEPTACLES, CABINETS, AND BOXES. SUBMIT SIX COPIES WITHIN THIRTY (30) DAYS AFTER CONTRACT AWARD, AND IN NOT MORE THAN TWO GROUPS OF SUBMITTALS. SUBMITTALS SHALL CONSIST OF LAYOUTS, WORKING DRAWINGS, CUTS, AND OPERATING AND PERFORMANCE DATA. ALLOW FOUR (4) WEEKS FOR REVIEW AND APPROVAL OF THE SHOP DRAWINGS BY ENGINEER.
- MATERIALS AND WORKMANSHIP: ALL MATERIALS AND EQUIPMENT SHALL BE NEW, OF BEST GRADE OF STANDARD MANUFACTURE, APPROVED BY UL, AND BE SO LABELED. FOR WIRE AND CABLE, MARKED AS REQUIRED BY ART. 310-2, NEC. INSTALLED BY SKILLED ELECTRICIAN WORKING UNDER THE DIRECT SUPERVISION OF COMPETENT EXPERIENCED FOREMAN AND/OR SUPERINTENDENT. PRODUCTS SHALL BE INSTALLED IN A THOROUGH WORKMANLIKE MANNER, PRESENTING A NEAT, CLEAN-CUT APPEARANCE WHEN COMPLETED. ANY PART OR PARTS NOT MEETING THIS REQUIREMENT SHALL BE REPLACED OR REBUILT WITHOUT EXTRA EXPENSE TO OWNER.
- PROTECTION OF EXISTING PLENUM CHIMNEY SHALL BE PROPERLY SECURED ABOVE CEILING PER APPLICABLE CODES.
- WIRING METHODS: THE DRAWINGS ARE DIAGRAMMATIC AND ARE INTENDED TO SHOW THE LOCATIONS OF EQUIPMENT AND ARRANGEMENT OF CIRCUITS ONLY. EXACT LOCATIONS SHALL BE DETERMINED BY ACTUAL MEASUREMENT AT THE SITE. CONTRACTOR SHALL BE FULLY RESPONSIBLE FOR ALL RISERS, DROPS, OFFSETS, ETC. NECESSARY TO AVOID CONFLICT WITH STRUCTURAL MEMBERS, AND SIMILAR ITEMS, WHEN INSTALLING ELECTRICAL CONDUITS. INSTALL EXPOSED CONDUIT AS SHOWN OR NOTED, PARALLEL TO HORIZONTAL AND VERTICAL LINES OF STRUCTURES. MAKE BENDS WITH 90 DEGREE TURN ONLY, OR WITH APPROVED FITTINGS.
- CONDUIT: FURNISH A COMPLETE RACEWAY SYSTEM FOR BUT NOT LIMITED TO FEEDER, BRANCH CIRCUITS, CONTROL WIRING, AND AUXILIARY SYSTEM WIRING.
 - USE LIQUID TIGHT FLEXIBLE METAL CONDUIT AND FITTINGS FOR ALL MOTORIZED CONNECTIONS, WHERE EQUIPMENT IS SUBJECT TO MOVEMENT, OR LOCATED OUTDOOR.
 - WHERE ENTERING PANELS, PULL BOXES, J-BOXES, OR OUTLET BOXES, SECURED IN PLACE WITH WITH LOCK-NUTS INSIDE AND OUTSIDE, AND INSULATED BUSHING INSIDE.
 - BENDS AND OFFSETS MADE WITH APPROVED TOOLS ONLY. BENDS OR OFFSETS IN WHICH THE PIPE IS CRUSHED OR DEFORMED SHALL NOT BE INSTALLED.
 - USE EMT FOR INTERIOR DRY LOCATIONS, PVC FOR UNDERGROUND INSTALLATION, AND RIGID GALVANIZED STEEL FOR EXPOSED LOCATIONS SUBJECT TO DAMAGE.
 - PLENUM RATED CABLE IS ACCEPTABLE FOR LOW VOLTAGE APPLICATION ABOVE LAY-IN CEILINGS.
- OUTLET AND JUNCTION BOXES: FURNISH AND INSTALL ALL JUNCTION BOXES REQUIRED TO FACILITATE INSTALLATION OF THE VARIOUS CONDUIT SYSTEMS. JUNCTION BOXES SHALL BE SUITABLE FOR ENVIRONMENT AND APPLICATION USED FOR.
 - WIRE AND CABLE: ALL WIRE AND CABLE SHALL:
 - BE NEW AND OF SOFT DRAWN, ANNEALED, COPPER HAVING A CONDUCTIVITY OF NOT LESS THAN 98% OF THAT OF PURE COPPER; EACH WIRE CONTINUOUS WITHOUT WELD, SPLICE OR JOINT THROUGHOUT ITS LENGTH; UNIFORM IN CROSS SECTION AND FREE FROM FLAWS, SCALES, AND OTHER IMPERFECTIONS.
 - UNLESS OTHERWISE SPECIFIED OR NOTED, WIRES SHALL BE #12 AWG (FOR PHASE, NEUTRAL, AND GROUND CONDUCTORS) TYPE THW, THHN, THWN, AS MANUFACTURED BY TRIANGLE, GENERAL ELECTRIC, OKONITE, OR ANCONDA.
 - ALL WIRE #8 AND LARGER SHALL BE STRANDED.
 - NOT BE DRAWN INTO A CONDUIT UNTIL ALL WORK WHICH MAY CAUSE INJURY TO INSULATION IS COMPLETE. WHERE TWO OR MORE CIRCUITS RUN TO A SINGLE OUTLET POINT, TAG EACH CIRCUIT AS A GUIDE.
 - HAVE ALL STRANDED CONDUCTORS FURNISHED WITH COPPER CONNECTING LUGS, DRILLED, OR REAMED THE FULL DIAMETER OF THE BARE CONDUCTORS, MAINS AND FEEDERS SHALL BE RUN THEIR ENTIRE LENGTH IN CONTINUOUS PIECES WITHOUT JOINTS OR SPLICES.
- IDENTIFICATION OF CONDUCTORS AND PANELBOARD ELEMENTS:
 - EACH AND EVERY MAIN AND FEEDER CONDUCTOR SHALL BE IDENTIFIED AT EACH OUTLET POINT WHERE SUCH CONDUCTOR TERMINATES. FEEDER BUNDLES PASSING THROUGH A JUNCTION OR SUPPORT BOX SHALL ALSO BE IDENTIFIED WITHIN SUCH ENCLOSURE, BUT MAY BE IDENTIFIED IN SUCH LOCATIONS AS A GROUP.
 - IDENTIFY BY USE OF PERMANENT TYPE BANDS, BRADY, OR T AND B. A DEFINITE NUMBER AND/OR LETTER CODE SHALL BE EMPLOYED AND BE UNIFORM THROUGHOUT EACH CONDUCTOR.
 - IDENTIFY EACH SWITCH, INCLUDING MAIN DISCONNECT AND MOTOR STARTER WITH WHITE-ON-BLACK NAMEPLATE, EACH HAVING 1/4" HIGH LETTERS, NEATLY AND SECURELY ADHERE NAMEPLATES TO THE UNIT.
- SWITCHES: FURNISH AND INSTALL ALL FUSIBLE AND NON-FUSIBLE SWITCHES AS REQUIRED BY CODES, WHETHER OR NOT SHOWN AND/OR NOTED. SWITCHES SHALL BE:
 - HEAVY DUTY WITH NEMA-1 OR 3R ENCLOSURE, AS REQUIRED, AND BE PROVIDED WITH PAD-LOCKING FEATURE.
 - PROVIDED AT EACH MOTOR THAT IS OUT OF SIGHT OF THE SWITCH OR PANEL FROM WHICH FED, AND BE NON-FUSIBLE DISCONNECT FOR SUCH USE.
 - SINGLE OR DOUBLE MANUFACTURER SHALL BE GE, WESTINGHOUSE, OR SQUARE D.
 - DISCONNECT SWITCHES INSTALLED OUTSIDE THE BUILDING SHALL BE IN NEMA-3 ENCLOSURES.
 - FUSIBLE SWITCH-STARTER UNITS: EACH UNIT SHALL BE TOTALLY ENCLOSED AND EFFECTIVELY BARRIRED, MANUALLY OPERATED QUICK-MAKE, QUICK BREAK, HORSEPOWER RATED STARTER. PROVIDE CLASS R TYPE REJECTION FUSE CLIPS.
 - IDENTIFY EACH DEVICE WITH NAMEPLATE SHOWING THE LOAD SERVED, MATCHING THE EXISTING NAMEPLATES.
- WIRING DEVICES: FURNISH AND INSTALL ALL WIRING DEVICES AS INDICATED ON THE DRAWINGS. DEVICES SHALL IN ALL CASES BE SUITABLE FOR THE USE INTENDED AND SHALL HAVE VOLTAGE AND CURRENT RATINGS ADEQUATE FOR THE LOADS TO BE SERVED.
 - MOUNTING: HEIGHTS OF ALL DEVICES ARE FROM FINISH FLOOR TO CENTERLINE OF DEVICE. DEVICES SHOWN ON THE DRAWINGS IN GROUPS OF TWO OR MORE SHALL BE LOCATED HORIZONTALLY IN SUCH A MANNER AS TO BE CLOSE AS POSSIBLE FROM THE CENTERLINE OF THE FIRST DEVICE TO THE CENTERLINE OF THE NEXT DEVICE UNLESS OTHERWISE NOTED.
 - WALL SWITCHES: SHALL BE LEVITON ROCKER TYPE, WHITE IN COLOR. USE CORRESPONDING DOUBLE POLE, THREE-WAY, FOUR-WAY, KEYED AND DIMMER SWITCHES WHERE NOTED. MOUNT AT 3'-0" A.F.F. AND WITHIN 6" OF ADJACENT DOOR JAMB, UNLESS OTHERWISE NOTED. USE "KEYED" SWITCHES IN LOCATIONS INDICATED.
 - CONVENIENCE OUTLETS: SHALL BE GROUNDING TYPE, 20 AMP, 125 VOLT, LEVITON, WHITE COLOR. WEATHERPROOF DUPLEX OUTLETS SHALL BE LEVITON 5342 WITH SIERRA NO. WPD-8 PLATE, MOUNT AT 18" A.F.F., UNLESS OTHERWISE NOTED. PROVIDE NEMA 5-20R DEVICES UNLESS OTHERWISE INDICATED. PROVIDE SPECIFICATION (SPEC) GRADE HEAVY DUTY STRAIGHT BLADE DEVICES UNLESS OTHERWISE NOTED. PROVIDE HOSPITAL GRADE DEVICES WHERE INDICATED, OR AS REQUIRED BY CODES.
 - ACCEPTABLE ALTERNATE MANUFACTURERS: SHALL BE LSI, H.E. WILLIAMS, HUBBELL, P&S AND BRYANT, PROVIDED THEIR DEVICES ARE OF THE SAME TYPE AND QUALITY AND THAT ONLY ONE MANUFACTURER SHALL BE USED THROUGHOUT THE WORK.
 - PLATES: SHALL BE MATCHING TYPE FOR FINISHED AREAS AND GALVANIZED STEEL FOR AREAS WITH EXPOSED CONDUIT. PROVIDE STAINLESS STEEL PLATES FOR FLUSH MOUNTED DEVICES. PROVIDE CAST ALUMINUM WET LOCATION TYPE COVER PLATES WITH HINGED COVERS FOR DEVICES LOCATED OUTSIDE. GANG OUTLETS GROUPED TOGETHER UNDER A SINGLE WALL PLATE.
 - INCANDESCENT DIMMERS: KEY SLIDE TO OFF, DEORA STYLE SIMILAR TO SWITCHES, WITH WATTAGE AS REQUIRED PER MANUFACTURER'S RECOMMENDATIONS. POWER FAILURE MEMORY, RFI SUPPRESSION, WHERE SWITCHES ARE SHOWN NEXT TO DIMMERS, PROVIDE MULTI-GANG COVER PLATES. PROVIDE DIMMERS WITH IVORY FINISH, SAME AS SWITCHES UNLESS OTHERWISE DIRECTED.
 - INSTALL WIRING DEVICES AND ACCESSORIES PLUMB AND LEVEL, IN ACCORDANCE WITH MANUFACTURER'S WRITTEN INSTRUCTIONS. APPLICABLE REQUIREMENTS OF NEC AND IN ACCORDANCE WITH RECOGNIZED INDUSTRY PRACTICES TO FULFILL PROJECT REQUIREMENTS.
 - TIGHTEN CONNECTORS AND TERMINALS, INCLUDING SCREWS AND BOLTS, IN ACCORDANCE WITH EQUIPMENT MANUFACTURER'S PUBLISHED TORQUE VALUES FOR WIRING DEVICES.
 - COORDINATE WITH OTHER WORK, INCLUDING PAINTING, ELECTRICAL BOXES AND WIRING INSTALLATIONS, AS NECESSARY TO INTERFACE INSTALLATION OF WIRING DEVICES WITH OTHER WORK.
 - INSTALL WIRING DEVICES AFTER WIRING WORK IS COMPLETED. INSTALL ONLY IN ELECTRICAL BOXES THAT ARE CLEAN, FREE FROM EXCESS BUILDING MATERIALS, DIRT, AND DEBRIS. INSTALL WALL PLATES AFTER PAINTING WORK IS COMPLETED.
 - NO RECEPTACLE OR SWITCH OUTLETS SHALL BE MOUNTED BACK TO BACK. A MINIMUM OF ONE (1) STUD MUST BE BETWEEN OUTLETS.
 - INSTALL RECEPTACLES WITH GROUND PIN UP. INSTALL SWITCHES WITH THE "ON" POSITION UP.
 - ALL EXTERIOR DEVICES TO BE WEATHER PROOF AND EXTERIOR RECEPTACLES SHALL BE A GFCI TYPE DEVICE.
 - ALL 120-VOLT RECEPTACLES OUTLETS LOCATED WITHIN SIX FEET OF SINKS SHALL HAVE GROUND FAULT CIRCUIT INTERRUPTER (GFCI) PROTECTION. ALL OUTLETS SHALL BE CONNECTED ON DEDICATED NEUTRAL WIRING SERVING ONLY THE INDIVIDUAL OUTLET WITH THE GROUND FAULT PROTECTION.
 - USE JUMBO SIZE WALL PLATES FOR OUTLETS INSTALLED IN MASONRY WALLS. DO NOT SHARE NEUTRAL CONDUCTORS ON DIMMERS.
 - PANELBOARD: PANELBOARDS SHALL BE GE TYPE AL, AG, OR AE OR APPROVED EQUAL. REFER TO CONDUIT SCHEDULES FOR THE TYPE AND NAMED. PROVIDE BRANCH CIRCUIT BREAKERS. ALL PANELBOARD BUSSING SHALL BE COPPER. PANELBOARDS SHALL BE IN OUTDOOR ENCLOSURE WHERE INSTALLED OUTDOOR. MINIMUM INTERRUPTING RATING FOR PANELS SHALL BE AS INDICATED ON DRAWINGS.
 - TRANSFORMERS: DRY TYPE, TWO-WINDING OF THE SIZE AND ELECTRICAL CHARACTERISTICS SHOWN AND SCHEDULED ON DRAWINGS. TRANSFORMERS SHALL BE EQUIPPED WITH 2-2-1/2% TAPS ABOVE AND BELOW RATING. TRANSFORMERS SHALL HAVE A BONDING JUMPER INSTALLED BETWEEN THE SECONDARY NEUTRAL TERMINAL AND METAL CASE, AND SHALL INCLUDE A GROUND TERMINAL OF PROPER SIZE TO RECEIVE GROUND CONDUCTOR. TRANSFORMERS SHALL BE RATED AT FULL LOAD IN A 40°C AMBIENT WITH 30°C ULTIMATE HOT SPOT TEMPERATURE RISE ALLOWANCE, WITH CLASS F INSULATION HAVING A UL 185°C RATING LIMITING SYSTEM TEMPERATURE TO 115°C ON UNITS SMALLER THAN 15 kVA AND CLASS H INSULATION HAVING UL 220°C RATING LIMIT SYSTEM TEMPERATURE TO 150°C ON 15 kVA AND LARGER UNITS. PROVIDE COPPER WINDINGS.
 - FUSES: FUSES IN MAIN, FEEDER, AND BRANCH CIRCUIT SWITCHES, RATED 600 AMPS AND BELOW, FEEDING MOTORS, TRANSFORMERS, AND GENERAL PURPOSE CIRCUITS (UNLESS OTHERWISE SPECIFIED), SHALL BE UL LISTED AND LABELED AS CURRENT LIMITING, TIME-DELAY, 200,000 A.I.C., CLASS RK-5 FUSES SHALL BE BUSSMAN TYPE FRN-R (250V), AND FR-8 (600V).
 - GROUNDING: ALL CONDUIT WORK, MOTOR, STARTERS, AND OTHER ELECTRICAL EQUIPMENT WIRING AND CONNECTED BY THIS CONTRACTOR SHALL BE EFFECTIVELY AND PERMANENTLY GROUND IN FULL ACCORDANCE WITH NEC 250.
 - OTHER MATERIALS: FURNISH AND INSTALL ALL OTHER MATERIALS SUCH AS HARDWARE, TAPE, CLAMPS, CONNECTORS, FITTINGS, SUPPORTS, AND ALL OTHER APPURTENANCES REQUIRED TO COMPLETE THE WORK TO THE FULL INTENT OF THE CONTRACT. TERMINAL LUGS SHALL BE FURNISHED BY THE ELECTRICAL CONTRACTOR.
 - ELECTRICAL CONTRACTOR IS RESPONSIBLE FOR ALL TEMPERATURE, CO2, AND HUMIDITY SENSOR STUB-UPS FOR THE MECHANICAL HVAC SYSTEM. REFER TO MECHANICAL PRINTS FOR SENSOR QUANTITY AND LOCATIONS.
 - ELECTRICAL CONTRACTOR WILL CONNECT ALL LOW VOLTAGE PLUMBING CONTRACTOR SUPPLIED TRANSFORMERS (FOR AUTOMATIC FLUSH) TO THE NEAREST 120V CIRCUIT (OR IF INDICATED ON PLANS WITH A CIRCUIT NUMBER). CONTRACTOR TO ASSUME ONE TRANSFORMER PER BATHROOM. THE PLUMBING CONTRACTOR WILL BE RESPONSIBLE FOR LOW VOLTAGE WIRING TO THE FIXTURES.
 - SWITCHGEAR AND DISTRIBUTION PANELS: SHALL BE FIELD MARKED TO WARN QUALIFIED PERSONS OF POTENTIAL ELECTRIC ARC FLASH HAZARDS. THE MARKING SHALL BE LOCATED SO AS TO BE CLEARLY VISIBLE TO QUALIFIED PERSONS BEFORE EXAMINATION, ADJUSTMENT, SERVICING, OR MAINTENANCE OF THE EQUIPMENT, NEC 110.16.
 - ELECTRICAL CONTRACTOR SHALL BE RESPONSIBLE FOR ALL ELECTRICAL APPARATUS DEVICES, APPLIANCES, FIXTURES, OR EQUIPMENT SHALL BE SOLD OR INSTALLED IN THE CITY UNLESS THEY ARE IN CONFORMANCE WITH THE PROVISIONS OF THIS CODE. THE LAWS OF THE STATE OF TEXAS AND ANY APPLICABLE RULES AND REGULATIONS ISSUED UNDER THE AUTHORITY OF THE STATE STATUTES, THE MAKER'S NAME, TRADEMARK, OR OTHER IDENTIFICATION SYMBOL, SHALL BE PLACED ON ALL ELECTRICAL MATERIALS, APPARATUS, DEVICES, APPLIANCES, FIXTURES, AND EQUIPMENT USED OR INSTALLED UNDER THE PROVISIONS OF THIS CODE. ALL ELECTRICAL MATERIALS AND EQUIPMENT SHALL BE LISTED AND LABELED FOR THE INTENDED USE AND SHALL BE INCLUDED IN A LIST PUBLISHED BY AN APPROVED AGENCY.

ISSUE #	DATE	DESCRIPTION
1	02/29/2016	100% CD
2	03/23/2016	Addendum 3
3	05/12/2016	VE Changes



INFRASTRUCTURE ASSOCIATES, INC.
617 RICHMOND AVENUE, SUITE 200
HOUSTON, TEXAS 77057
TELE REGISTRATION NO. P-4506
(713) 622-0120 PH (713) 622-0557 FAX
WWW.IAHOUSTON.COM



Boucher Design Group LLC
Members A.I.A.
6802 Maple Ridge, Suite 200
Bellaire, Texas 77401
Tel. 713.785.3644
www.bdgap.com

This document is an instrument of service protected by the copyright law of the United States of America, 17 U.S.C §102, and shall not be copied or reproduced without the express written consent of Boucher Design Group, LLC, 2016



BAYSIDE COMMUNITY CENTER	
BACLIFF, TEXAS	
GALVESTON COUNTY	
DATE	02/29/16
PROJECT NO.	1409000
DRAWN BY	CC/CJCT
CHECKED BY	WJK/DG

NOTES AND SCHEDULES

E102

PANEL: HA		LOCATION: DATA 13		MTG: SURFACE		BUS: NEUTRAL		INT TVSS		NEMA-1 ENC		3 0 4 WIRE	
		FLUSH		ISO GND		OPT		FEED THRU		CU		AMP MLD 35 KAC	
		ISO GND		ISO GND		ISO GND		ISO GND		ISO GND		AMP MCB 480Y/277 VOLT	
WIRE SIZE	LOAD DESCRIPTION	LOAD KVA	BRKR SIZE	CKT NO	A	B	C	CTK NO	BRKR SIZE	LOAD KVA	LOAD DESCRIPTION	WIRE SIZE	
#10	EXTERIOR POLE LIGHTING	0.1	20/1	1				2	20/1	3.6	LIGHTING FIXTURES - ASSEMBLY/STOR.	#12	
#10	EXTERIOR POLE LIGHTING	0.7	20/1	3				4	20/1	1.6	LIGHTING FIXTURES - HALL/RR/OFFICE	#12	
#10	EXTERIOR POLE LIGHTING	0.4	20/1	5				6	20/1	0.1	EXT LIGHT FIXTURES	#12	
#10	EXTERIOR POLE LIGHTING	1.4	20/1	7				8	20/1	0.4	EXTERIOR LIGHTING - CANPOY	#12	
#10	EXTERIOR BOLLARD LIGHTING	0.3	20/1	9				10	20/1	0.4	EXTERIOR LIGHTING - SMALL LOT	#12	
#10	EXTERIOR WALL PACKS	0.2	20/1	11				12	20/1	-	SPARE	-	
-	SPARE	-	20/1	13				14	20/1	-	SPARE	-	
-	SPARE	-	20/1	15				16	20/1	-	SPARE	-	
-	SPARE	-	20/1	17				18	20/1	-	SPARE	-	
-	SPARE	-	20/1	19				20	20/1	-	SPARE	-	
-	SPARE	-	20/1	21				22	20/1	-	SPARE	-	
-	SPARE	-	20/1	23				24	20/1	-	SPARE	-	
-	SPACE	-	-	25				26	-	-	SPACE	-	
-	SPACE	-	-	27				28	-	-	SPACE	-	
-	SPACE	-	-	29				30	-	-	SPACE	-	
-	SPACE	-	-	31				32	-	-	SPACE	-	
-	SPACE	-	-	33				34	-	-	SPACE	-	
-	SPACE	-	-	35				36	-	-	SPACE	-	
-	SPACE	-	-	37				38	-	-	SPACE	-	
-	SPACE	-	-	39				40	-	-	SPACE	-	
-	SPACE	-	-	41				42	-	-	SPACE	-	
-	SPACE	-	-	43				44	-	-	SPACE	-	
-	SPACE	-	-	45				46	-	-	SPACE	-	
-	SPACE	-	-	47				48	-	-	SPACE	-	
-	SPACE	-	-	49				50	-	-	SPACE	-	
-	SPACE	-	-	51				52	-	-	SPACE	-	
-	SPACE	-	-	53				54	-	-	SPACE	-	
-	SPACE	-	-	55				56	-	-	SPACE	-	
-	SPACE	-	-	57				58	-	-	SPACE	-	
-	SPACE	-	-	59				60	-	-	SPACE	-	
-	SPACE	-	-	61				62	-	-	SPACE	-	
-	SPACE	-	-	63				64	-	-	SPACE	-	
-	SPACE	-	-	65				66	-	-	SPACE	-	
-	SPACE	-	-	67				68	-	-	SPACE	-	
-	SPACE	-	-	69				70	-	-	SPACE	-	
-	SPACE	-	-	71				72	-	-	SPACE	-	
-	SPACE	-	-	73				74	-	-	SPACE	-	
-	SPACE	-	-	75				76	-	-	SPACE	-	
-	SPACE	-	-	77				78	-	-	SPACE	-	
-	SPACE	-	-	79				80	-	-	SPACE	-	
-	SPACE	-	-	81				82	-	-	SPACE	-	
-	SPACE	-	-	83				84	-	-	SPACE	-	
-	SPACE	-	-	85				86	-	-	SPACE	-	
-	SPACE	-	-	87				88	-	-	SPACE	-	
-	SPACE	-	-	89				90	-	-	SPACE	-	
-	SPACE	-	-	91				92	-	-	SPACE	-	
-	SPACE	-	-	93				94	-	-	SPACE	-	
-	SPACE	-	-	95				96	-	-	SPACE	-	
-	SPACE	-	-	97				98	-	-	SPACE	-	
-	SPACE	-	-	99				100	-	-	SPACE	-	
-	SPACE	-	-	101				102	-	-	SPACE	-	
-	SPACE	-	-	103				104	-	-	SPACE	-	
-	SPACE	-	-	105				106	-	-	SPACE	-	
-	SPACE	-	-	107				108	-	-	SPACE	-	
-	SPACE	-	-	109				110	-	-	SPACE	-	
-	SPACE	-	-	111				112	-	-	SPACE	-	
-	SPACE	-	-	113				114	-	-	SPACE	-	
-	SPACE	-	-	115				116	-	-	SPACE	-	
-	SPACE	-	-	117				118	-	-	SPACE	-	
-	SPACE	-	-	119				120	-	-	SPACE	-	
-	SPACE	-	-	121				122	-	-	SPACE	-	
-	SPACE	-	-	123				124	-	-	SPACE	-	
-	SPACE	-	-	125				126	-	-	SPACE	-	
-	SPACE	-	-	127				128	-	-	SPACE	-	
-	SPACE	-	-	129				130	-	-	SPACE	-	
-	SPACE	-	-	131				132	-	-	SPACE	-	
-	SPACE	-	-	133				134	-	-	SPACE	-	
-	SPACE	-	-	135				136	-	-	SPACE	-	
-	SPACE	-	-	137				138	-	-	SPACE	-	
-	SPACE	-	-	139				140	-	-	SPACE	-	
-	SPACE	-	-	141				142	-	-	SPACE	-	
-	SPACE	-	-	143				144	-	-	SPACE	-	
-	SPACE	-	-	145				146	-	-	SPACE	-	
-	SPACE	-	-	147				148	-	-	SPACE	-	
-	SPACE	-	-	149				150	-	-	SPACE	-	
-	SPACE	-	-	151				152	-	-	SPACE	-	
-	SPACE	-	-	153				154	-	-	SPACE	-	
-	SPACE	-	-	155				156	-	-	SPACE	-	
-	SPACE	-	-	157				158	-	-	SPACE	-	
-	SPACE	-	-	159				160	-	-	SPACE	-	
-	SPACE	-	-	161				162	-	-	SPACE	-	
-	SPACE	-	-	163				164	-	-	SPACE	-	
-	SPACE	-	-	165				166	-	-	SPACE	-	
-	SPACE	-	-	167				168	-	-	SPACE	-	
-	SPACE	-	-	169				170	-	-	SPACE	-	
-	SPACE	-	-	171				172	-	-	SPACE	-	
-	SPACE	-	-	173				174	-	-	SPACE	-	
-	SPACE	-	-	175				176	-	-	SPACE	-	
-	SPACE	-	-	177				178	-	-	SPACE	-	
-	SPACE	-	-	179				180	-	-	SPACE	-	
-	SPACE	-	-	181				182	-	-	SPACE	-	
-	SPACE	-	-	183				184	-	-	SPACE	-	
-	SPACE	-	-	185				186	-	-	SPACE	-	
-	SPACE	-	-	187				188	-	-	SPACE	-	
-	SPACE	-	-	189				190	-	-	SPACE	-	
-	SPACE	-	-	191				192	-	-	SPACE	-	
-	SPACE	-	-	193				194	-	-	SPACE	-	
-	SPACE	-	-	195				196	-	-	SPACE	-	
-	SPACE	-	-	197				198	-	-	SPACE	-	
-	SPACE	-	-	199				200	-	-	SPACE	-	
-	SPACE	-	-	201				202	-	-	SPACE	-	
-	SPACE	-	-	203				204	-	-	SPACE	-	
-	SPACE	-	-	205				206	-	-	SPACE	-	
-	SPACE	-	-	207				208	-	-	SPACE	-	
-	SPACE	-	-	209				210	-	-	SPACE	-	
-	SPACE	-	-	211				212	-	-	SPACE	-	
-	SPACE	-	-	213				214	-	-	SPACE	-	
-	SPACE	-	-	215				216	-	-	SPACE	-	
-	SPACE	-	-	217				218	-	-	SPACE	-	
-	SPACE	-	-	219				220	-	-	SPACE	-	
-	SPACE	-	-	221				222	-	-	SPACE	-	
-	SPACE	-	-	223				224	-	-	SPACE	-	
-	SPACE	-	-	225				226	-	-	SPACE	-	
-	SPACE	-	-	227				228	-	-	SPACE	-	
-	SPACE	-	-	229				230	-	-	SPACE	-	
-	SPACE	-	-	231				232	-	-	SPACE	-	
-	SPACE	-	-	233				234	-	-	SPACE	-	
-	SPACE	-	-	235				236	-	-	SPACE	-	
-	SPACE	-	-	237				238	-	-	SPACE	-	
-	SPACE	-	-	239				240	-	-	SPACE	-	
-	SPACE	-	-	241				242	-	-	SPACE	-	
-	SPACE	-	-	243				244	-	-	SPACE	-	
-	SPACE	-	-	245				246	-	-	SPACE	-	
-	SPACE	-	-	247				248	-	-	SPACE	-	
-	SPACE	-	-	249				250	-	-	SPACE	-	
-	SPACE	-	-	251				252	-	-	SPACE	-	
-	SPACE	-	-	253				254	-	-	SPACE	-	
-	SPACE	-	-	255				256	-	-	SPACE	-	
-	SPACE	-	-	257				258	-	-	SPACE	-	
-	SPACE	-	-	259				260	-	-	SPACE	-	
-	SPACE	-	-	261				262	-	-	SPACE	-	
-	SPACE												

ISSUE #	DATE	DESCRIPTION
0	02/29/2016	100% CD

Infrastructure Associates
 INFRASTRUCTURE ASSOCIATES, INC.
 617 RICHMOND AVENUE, SUITE 200
 HOUSTON, TEXAS 77057
 TFP# REGISTRATION NO. F-4566
 (713) 622-0120 PH (713) 622-0557 FAX
 WWW.IAHOUSTON.COM



Boucher Design Group LLC
 Members A.I.A.
 6802 Mapleridge, Suite 200
 Bellaire, Texas 77401
 Tel. 713.785.3644
 www.bdgap.com

This document is an instrument of service protected by the copyright law of the United States of America, 17 U.S.C §102, and shall not be copied or reproduced without the express written consent of Boucher Design Group, LLC. 2016

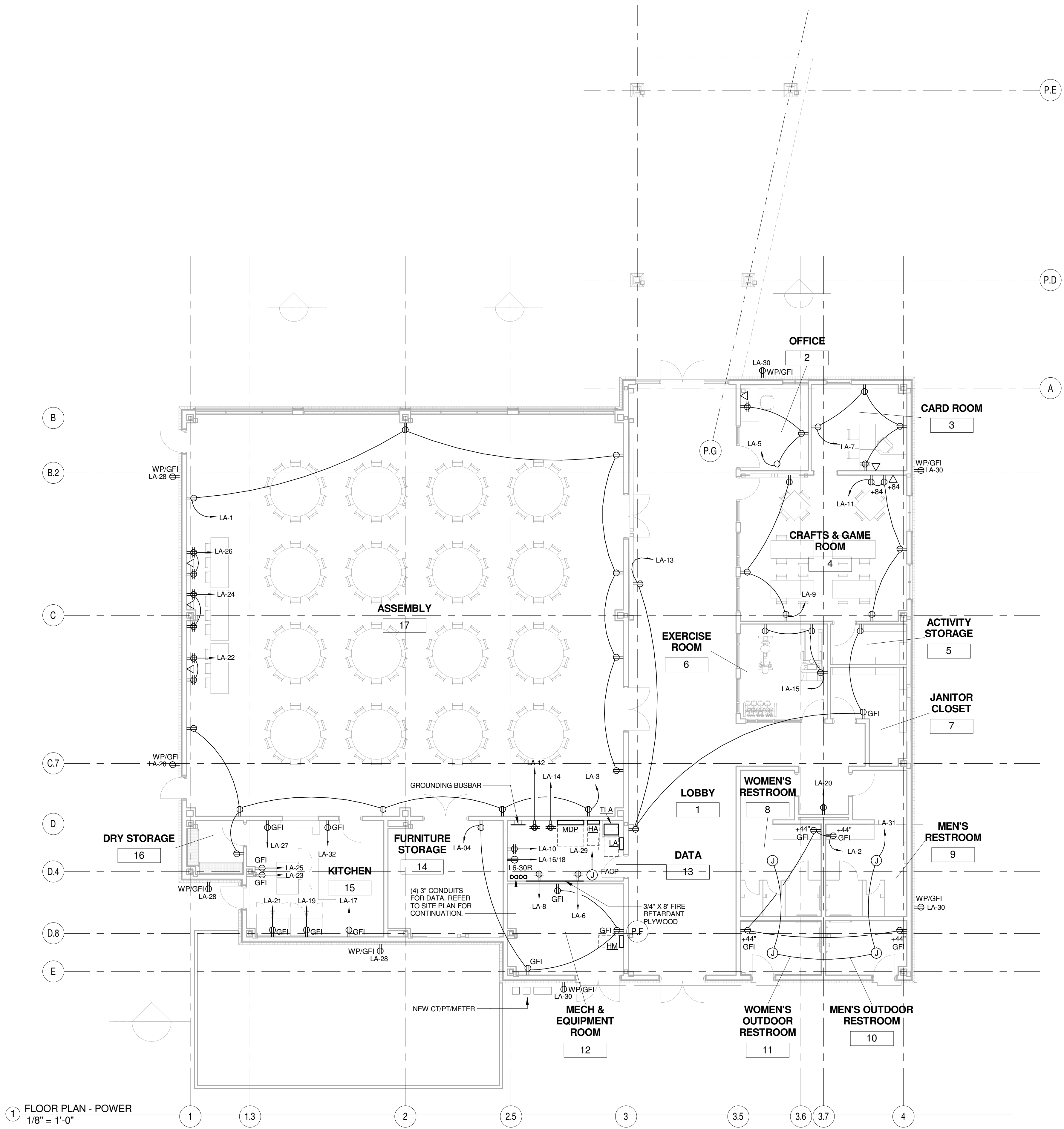
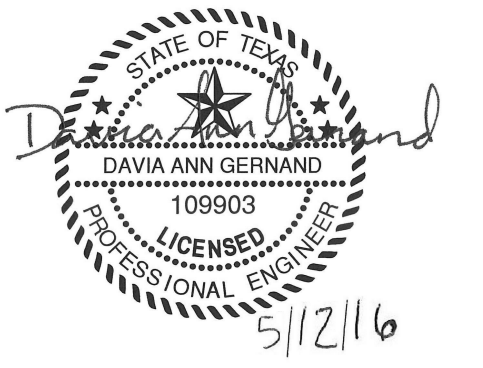

1 FLOOR PLAN - POWER
 1/8" = 1'-0"

C:\Users\Davia\Documents\Galveston Community Center - MEP - R2015_Davia.dwg 6/9/2016 11:22:20 AM

BAYSIDE COMMUNITY CENTER	
BACLIFF, TEXAS	
GALVESTON COUNTY	
DATE	02/29/2016
PROJECT NO.	1409000
DRAWN BY	OC/CJ/CT
CHECKED BY	WJK/DG

ELECTRICAL FLOOR PLAN - POWER

ISSUE #	DATE	DESCRIPTION
0	02/29/2016	100% CD
1	03/23/2016	Addendum 3
2	05/12/2016	VE Changes

Infrastructure Associates
 INFRASTRUCTURE ASSOCIATES, INC.
 617 RICHMOND AVENUE, SUITE 200
 HOUSTON, TEXAS 77005
 TFP# REGISTRATION NO. F-4566
 (713) 622-0120 PH (713) 622-0557 FAX
 WWW.IAHOUSTON.COM



Boucher Design Group LLC
 Members A.I.A.
 6802 Mapleridge, Suite 200
 Bellaire, Texas 77401
 Tel. 713.785.3644
 www.bdgap.com

This document is an instrument of service protected by the copyright law of the United States of America, 17 U.S.C §102, and shall not be copied or reproduced without the express written consent of Boucher Design Group, LLC. 2016

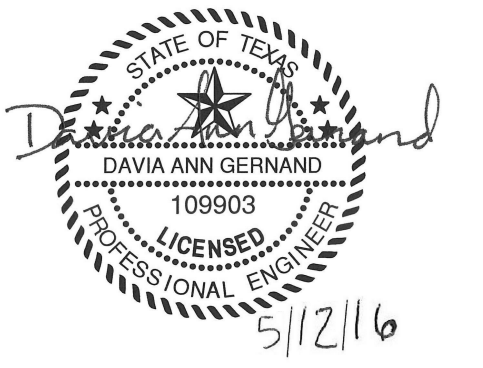

BAYSIDE COMMUNITY CENTER	
BACLIFF, TEXAS	
GALVESTON COUNTY	
DATE	02/29/16
PROJECT NO.	1409000
DRAWN BY	OC/CJ/CT
CHECKED BY	WJK/DG

EQUIPMENT PLAN - POWER

E211

© COPYRIGHT 2016 BOUCHER DESIGN GROUP, LLC

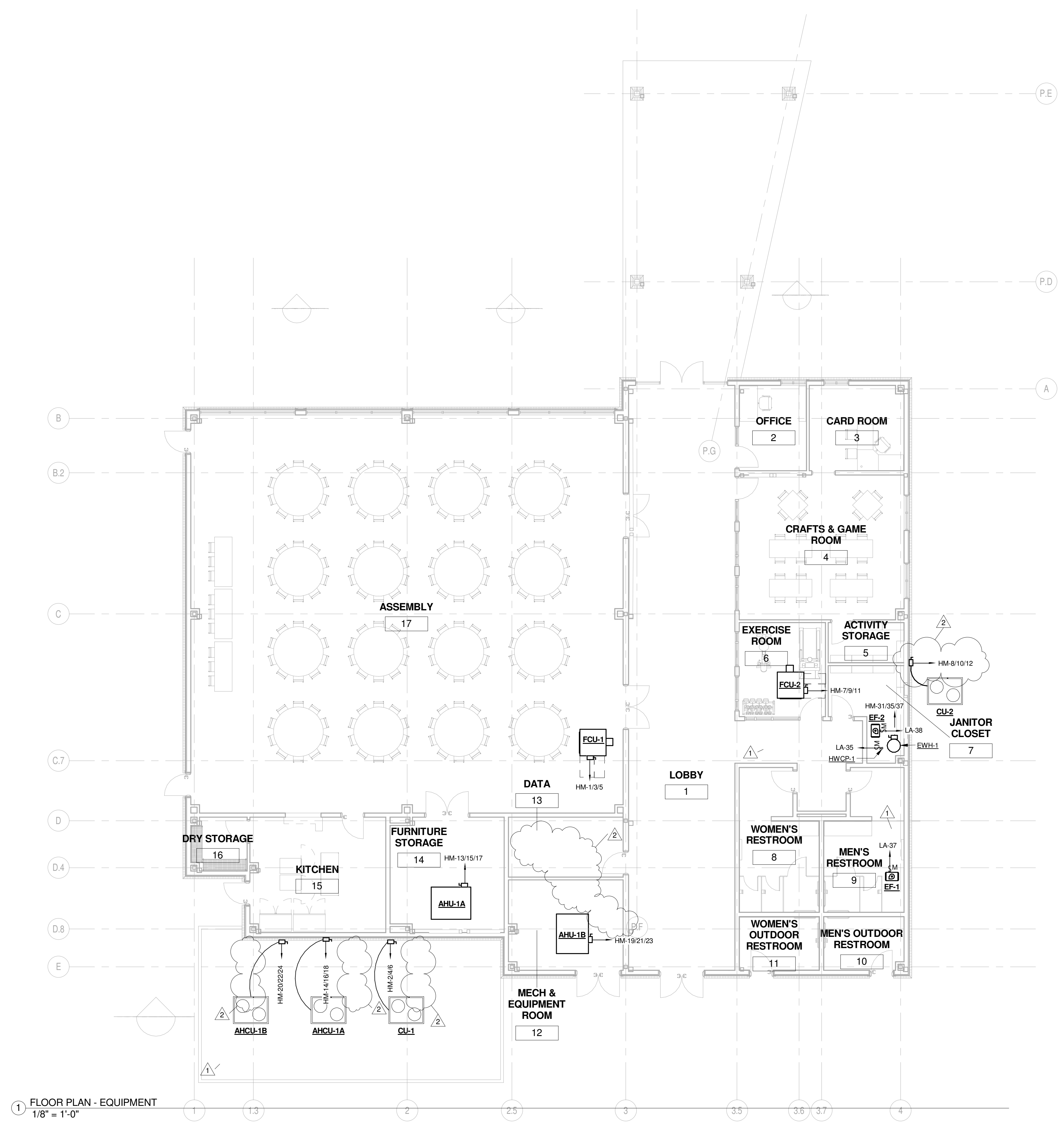

1 FLOOR PLAN - EQUIPMENT
 1/8" = 1'-0"

C:\Users\charnoir\Documents\Galveston Community Center - MEP - R2015_Chanceir.rvt 6/9/2016 10:22:49 AM

ISSUE #	DATE	DESCRIPTION
0	02/29/2016	100% CD

DELEGATED FIRE ALARM DESIGN REQUIREMENTS

THESE FIRE ALARM DOCUMENTS ARE INTENDED TO SHOW MINIMUM REQUIRED DETECTION AND NOTIFICATION DEVICES ONLY. THE AWARDED CONTRACTOR IS RESPONSIBLE FOR A COMPLETE FIRE ALARM SYSTEM DELEGATED-DESIGN. THE CONTRACTOR IS REQUIRED TO PROVIDE NOT ONLY DEVICES SHOWN IN THE DOCUMENTS AS A MINIMUM, BUT ALSO THOSE DEVICES REQUIRED TO MEET CODE, PROJECT SPECIFICATIONS REQUIREMENTS, AND THE AHJ REQUIREMENTS. THE CONTRACTOR IS REQUIRED TO COMPLY WITH PERFORMANCE REQUIREMENTS AND DESIGN CRITERIA, INCLUDING SIGNED AND SEALED CALCULATIONS BY QUALIFIED PROFESSIONAL ENGINEER RESPONSIBLE FOR SHOP DRAWING PREPARATION. THE CONTRACTOR SHALL PRODUCE SHOP DRAWINGS, REQUIRED BATTERY POWER CALCULATIONS, INTERCONNECTION WIRING DIAGRAMS, POWER SUPPLY DESIGN AND REQUIREMENTS, ETC. THESE DOCUMENTS SHALL BE SUBMITTED BY THE CONTRACTOR FOR REVIEW AND/OR APPROVAL BY THE AHJ AND A/E TEAM AS REQUIRED.

Infrastructure Associates
 INFRASTRUCTURE ASSOCIATES, INC.
 617 RICHMOND AVENUE, SUITE 200
 HOUSTON, TEXAS 77057
 TBP# REGISTRATION NO. F-4566
 (713) 622-0120 PH (713) 622-0557 FAX
 WWW.IAHOUSTON.COM

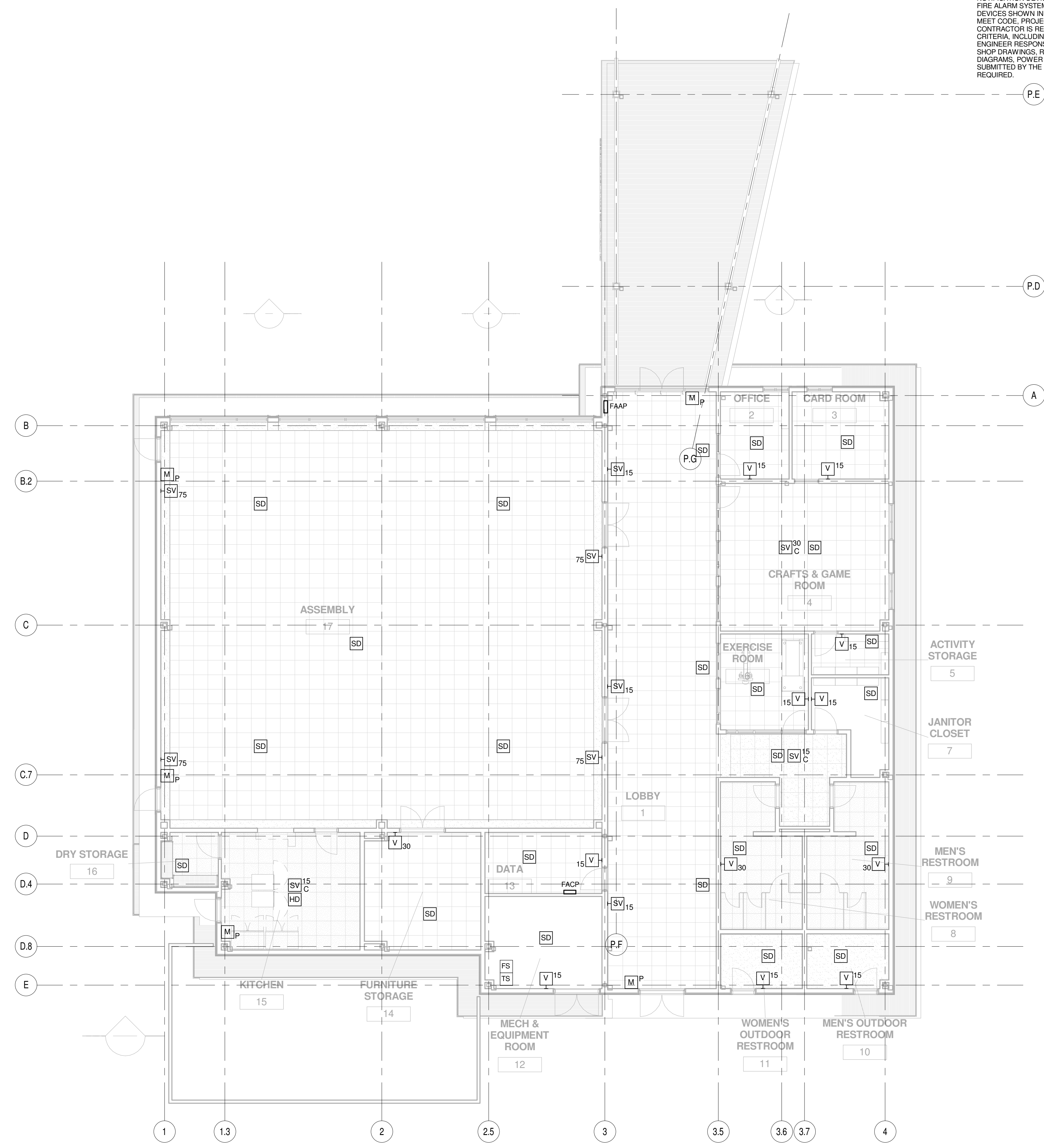

1 FLOOR PLAN - SPECIAL SYSTEMS
 1/8" = 1'-0"



Boucher Design Group LLC
 Members A.I.A.
 6802 Mapleridge, Suite 200
 Bellaire, Texas 77401
 Tel. 713.785.3644
 www.bdgap.com

This document is an instrument of service protected by the copyright law of the United States of America, 17 U.S.C §102, and shall not be copied or reproduced without the express written consent of Boucher Design Group, LLC. 2016

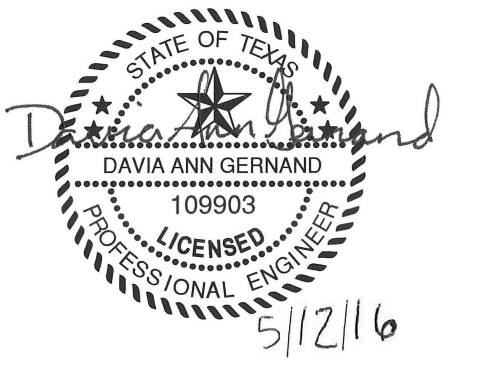

BAYSIDE COMMUNITY CENTER	
BACLIFF, TEXAS	
GALVESTON COUNTY	
DATE	02/29/16
PROJECT NO.	1409000
DRAWN BY	OC/CJCT
CHECKED BY	WJK/DG

FLOOR PLAN - SPECIAL SYSTEMS

E401

ISSUE #	DATE	DESCRIPTION
1	02/29/2016	100% CD

Infrastructure Associates
 INFRASTRUCTURE ASSOCIATES, INC.
 617 RICHMOND AVENUE, SUITE 200
 HOUSTON, TEXAS 77057
 TEPF REGISTRATION NO. F-4506
 (713) 622-0120 PH (713) 622-0557 FAX
 WWW.IAHOUSTON.COM

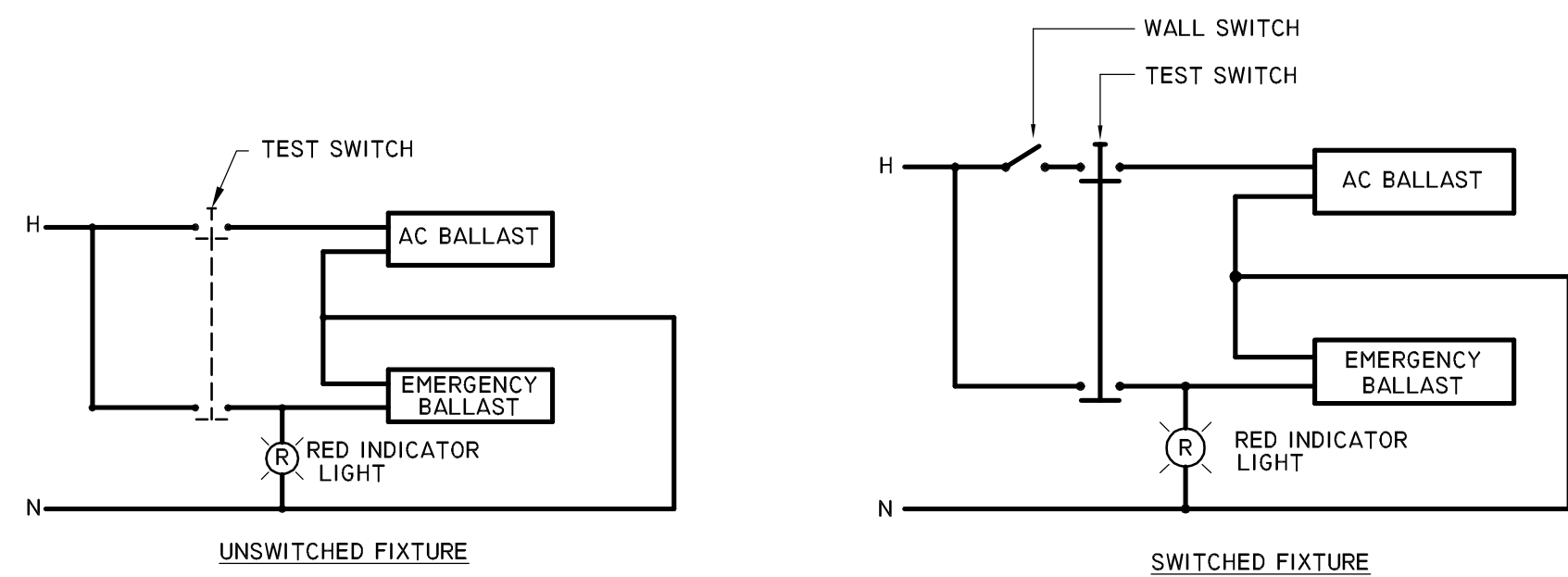

EMERGENCY LIGHTS ON THIS CIRCUIT WILL RECEIVE A HOT LEG WHICH IS NOT ROUTED VIA THE LIGHTING CONTROLLER SO THAT THE EMERGENCY BALLAST HAS A CONSTANT HOT TO DETECT POWER LOSS.

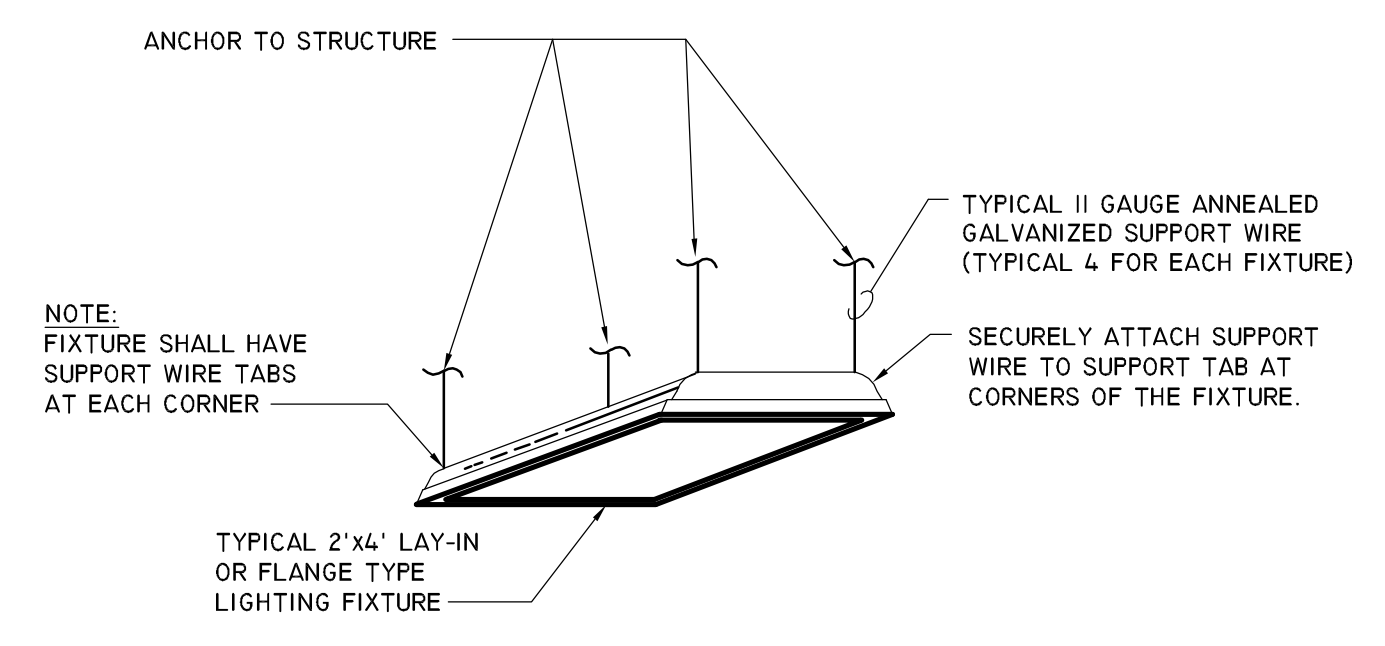

NOTE: FIXTURE SHALL HAVE SUPPORT WIRE TABS AT EACH CORNER

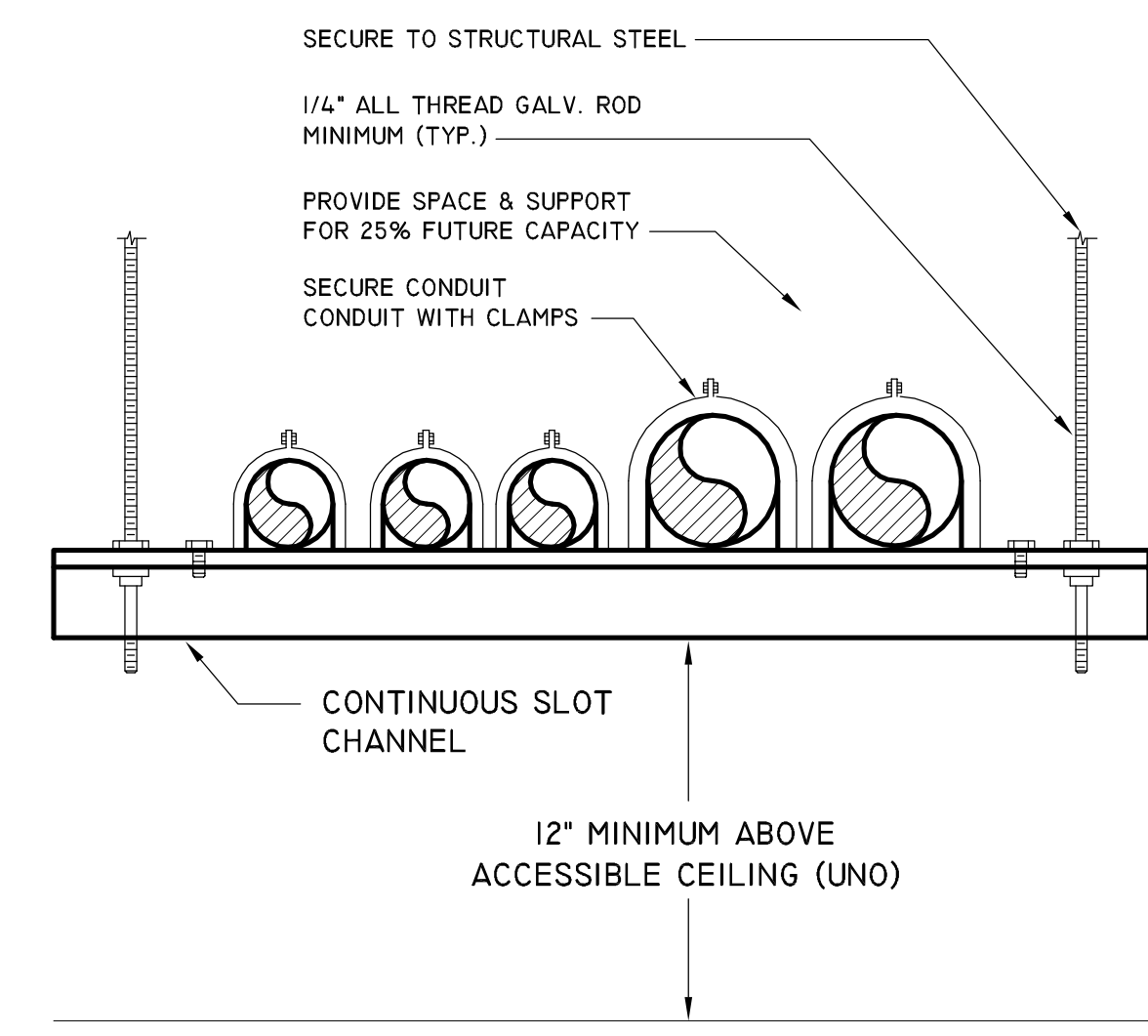

DETAIL - EMERGENCY BALLAST

NOT TO SCALE 9

DETAIL - FIXTURE SUPPORT

NOT TO SCALE 6

DETAIL - CONDUIT RACK

NOT TO SCALE 3

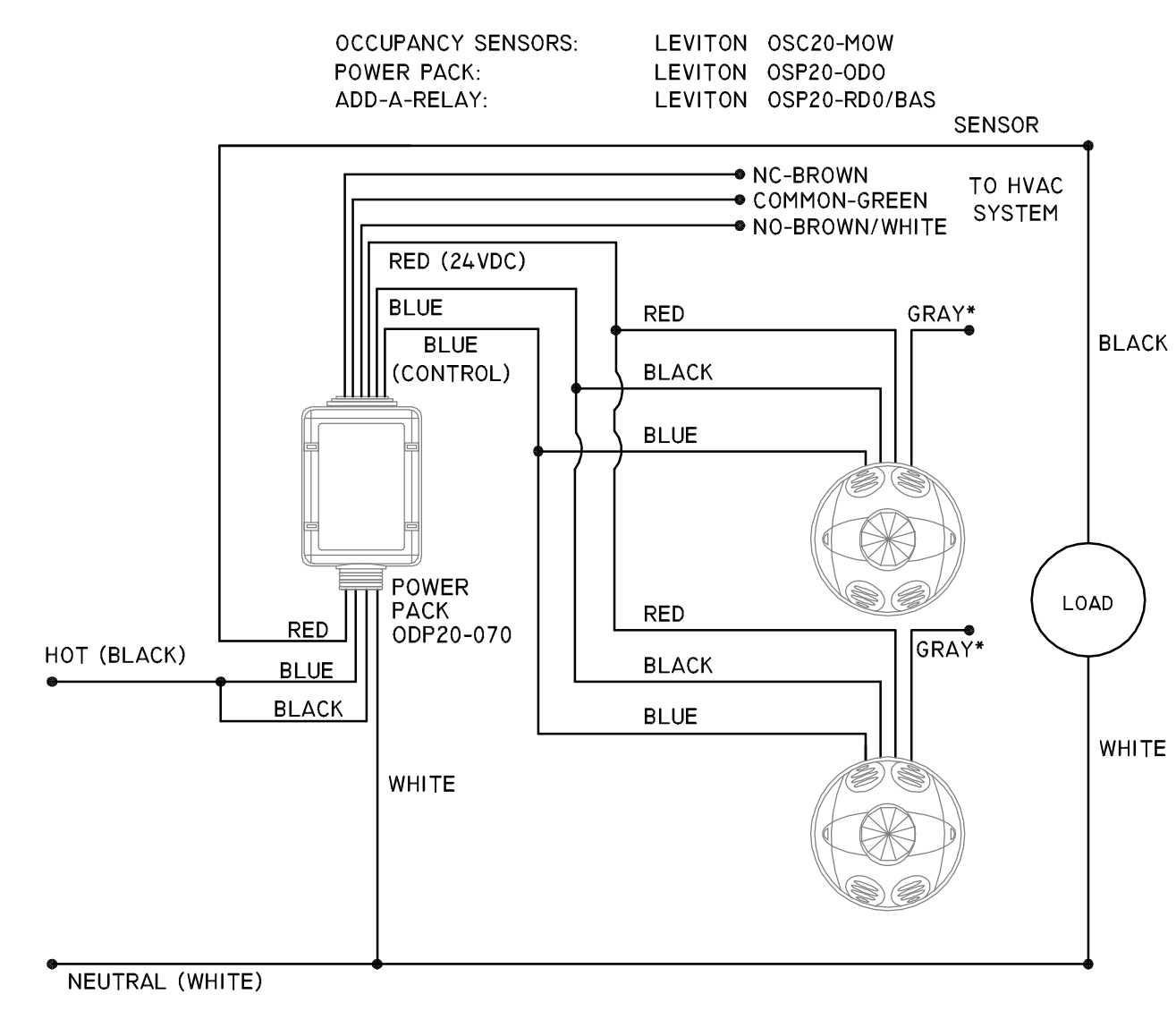

DETAIL - CEILING OCCUPANCY SENSOR

NOT TO SCALE 8

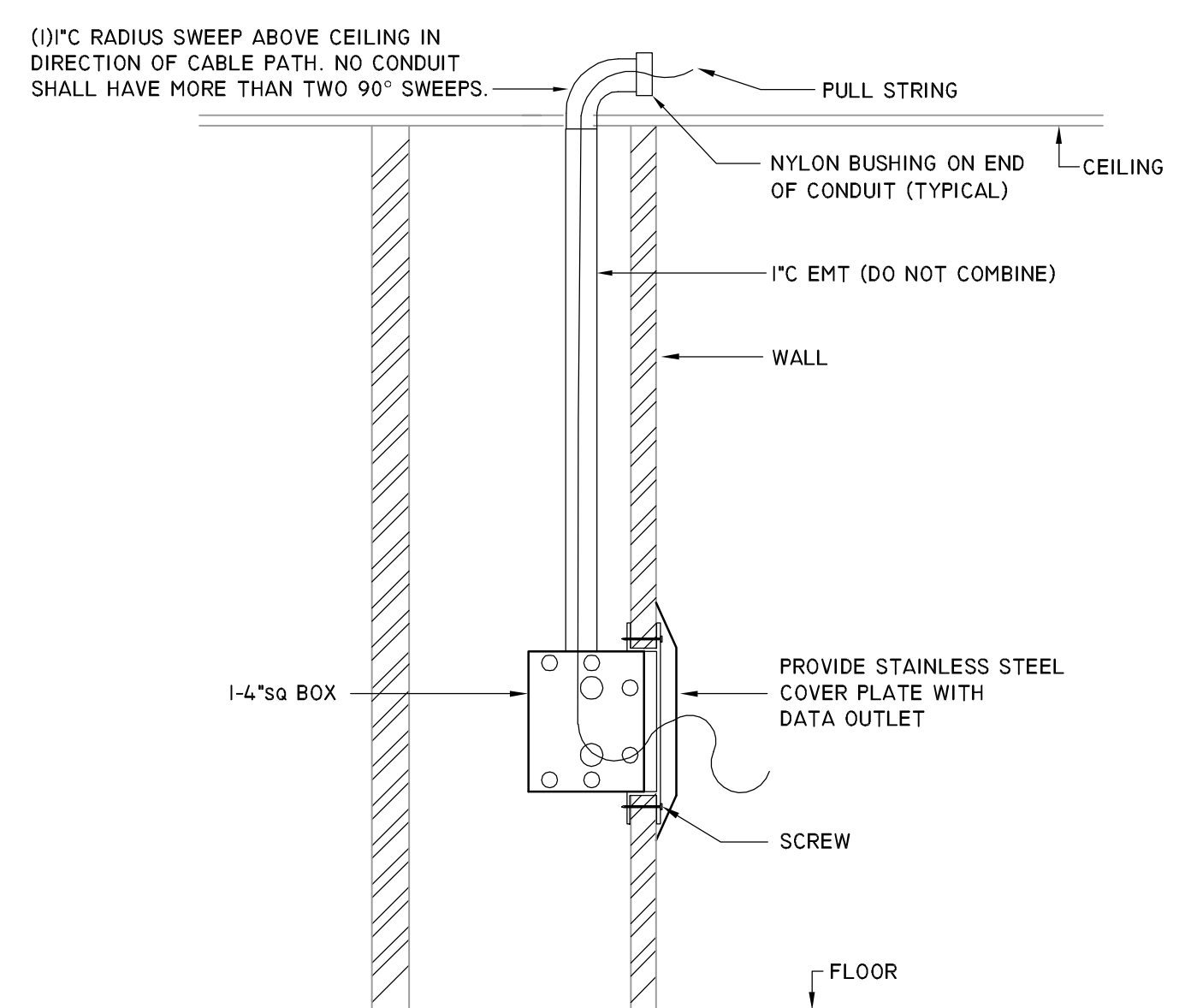

DETAIL - DATA OUTLETS

NOT TO SCALE 5

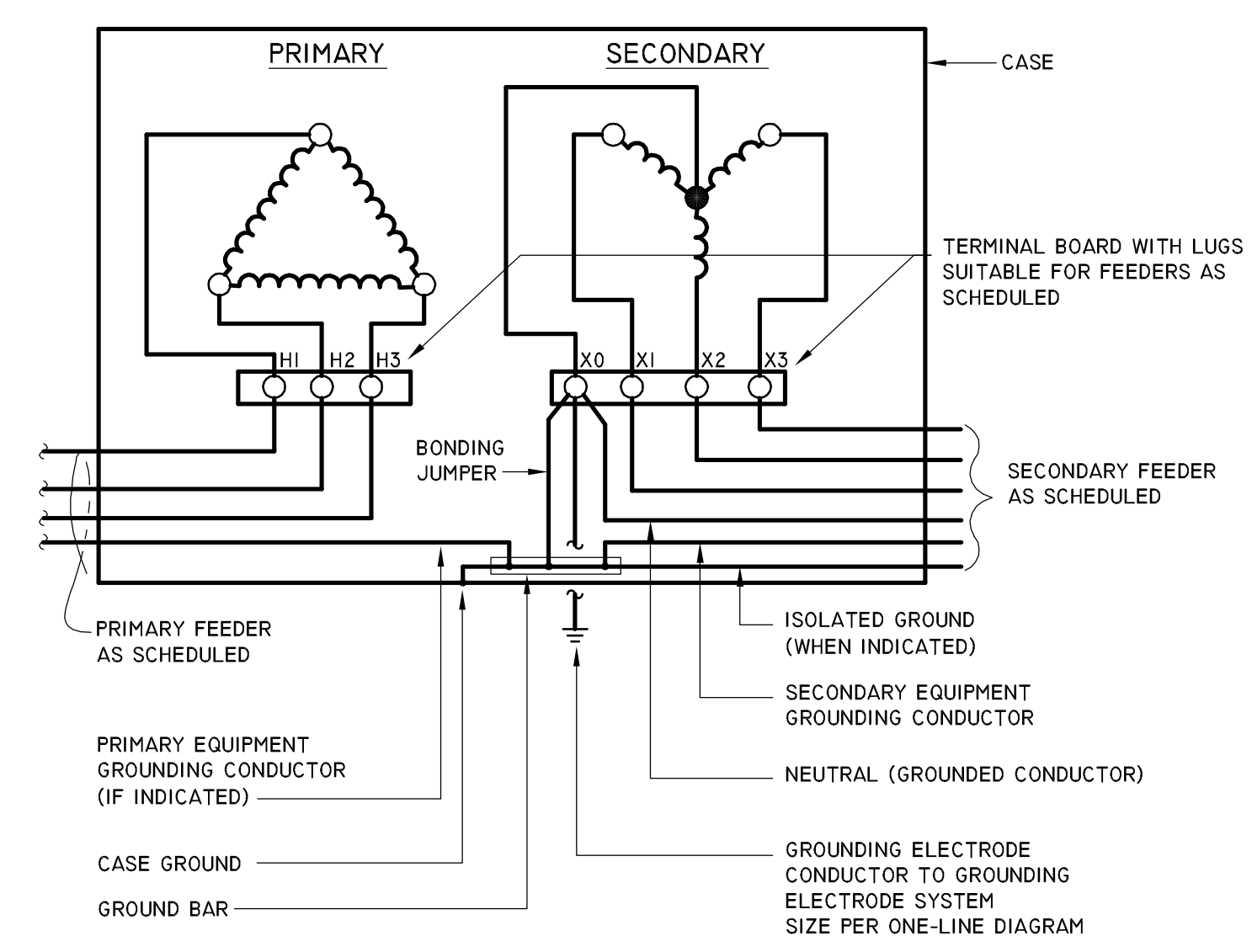

DETAIL - TRANSFORMER GROUNDING

NOT TO SCALE 2

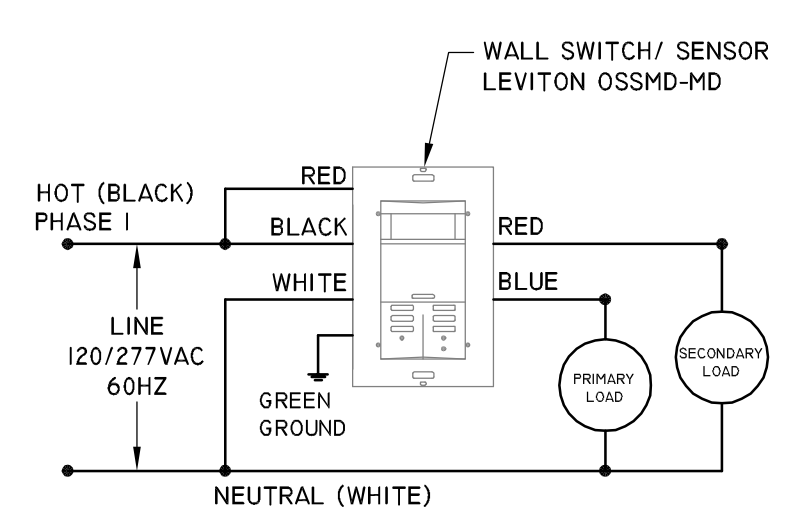

DETAIL - WALL OCCUPANCY SENSOR

NOT TO SCALE 7

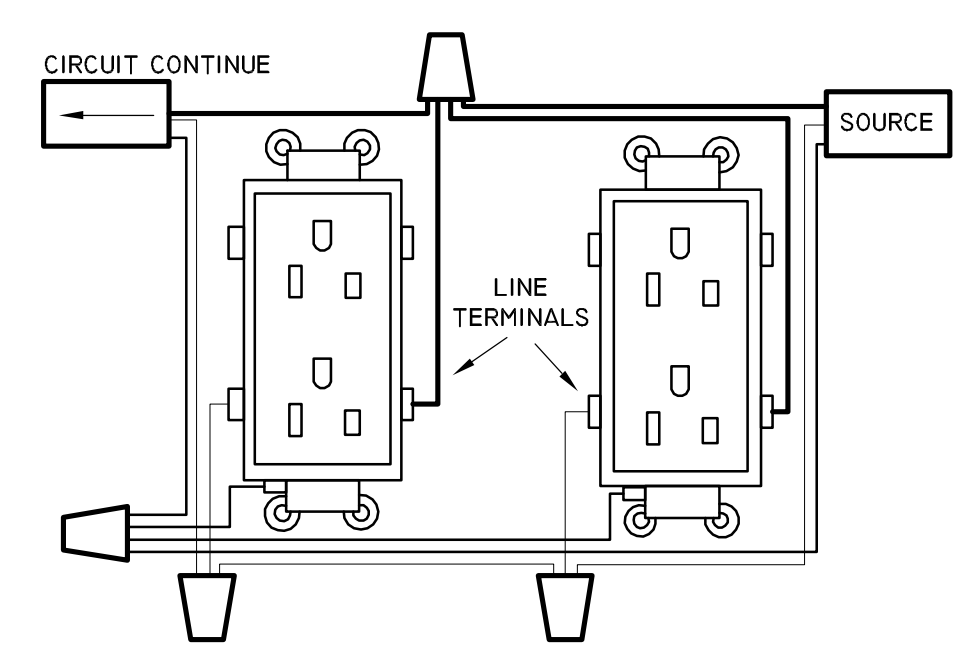

NOTES:
 1. CIRCUITING TO ALL NON DEDICATED ELECTRICAL RECEPTACLES AND SWITCHES ARE REQUIRED TO UTILIZE PARALLEL CIRCUITING BY THE USE OF "PIG TAILS" TO EACH DEVICE SO THAT IF AN OUTLET IS REMOVED OR FAILS ELECTRICAL CONTINUITY THE CIRCUIT WILL NOT BE COMPROMISED.
 2. ALL ELECTRICAL WIRING MUST BE PROPERLY SPLICED BY TWISTING THE WIRES TOGETHER AND USE OF APPROVED AND LISTED COMPRESSION WIRE NUTS FOR ANY WIRING.
 3. DO NOT USE END TO END BUTT-SPLICING CONNECTORS FOR ANY WIRING.

DETAIL - PIGTAIL

NOT TO SCALE 4

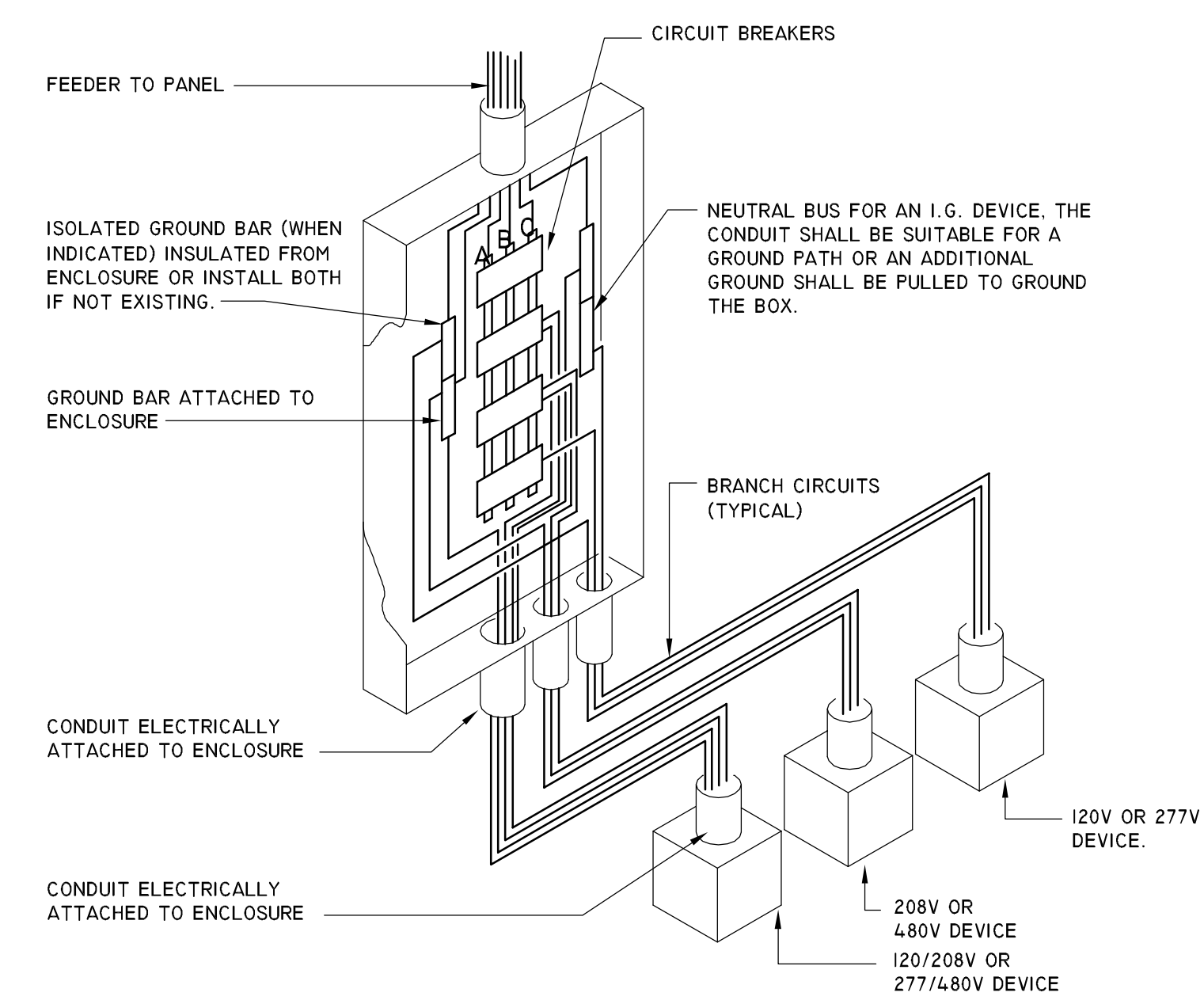

DETAIL - PANEL GROUNDING

NOT TO SCALE 1

bdg
 architecture
 + planning
 boucher design group

Boucher Design Group LLC
 Members A.I.A.
 6802 Maple Ridge, Suite 200
 Bellaire, Texas 77401
 Tel. 713.785.3644
 www.bdgap.com

This document is an instrument of service protected by the copyright law of the United States of America, 17 U.S.C §102, and shall not be copied or reproduced without the express written consent of Boucher Design Group, LLC. 2016



BAYSIDE COMMUNITY CENTER
 BA CLIFF, TEXAS
 GALVESTON COUNTY

DATE	02/29/16
PROJECT NO.	1409000
DRAWN BY	OC/CJCT
CHECKED BY	WJK/DG

DETAILS

E501

ISSUE #	DATE	DESCRIPTION
1	02/29/2016	100% CD

Infrastructure Associates
 INFRASTRUCTURE ASSOCIATES, INC.
 617 RICHMOND AVENUE, SUITE 200
 HOUSTON, TEXAS 77057
 TEPER REGISTRATION NO. F-4506
 (713) 622-0120 PH (713) 622-0557 FAX
 WWW.IAHOUSTON.COM

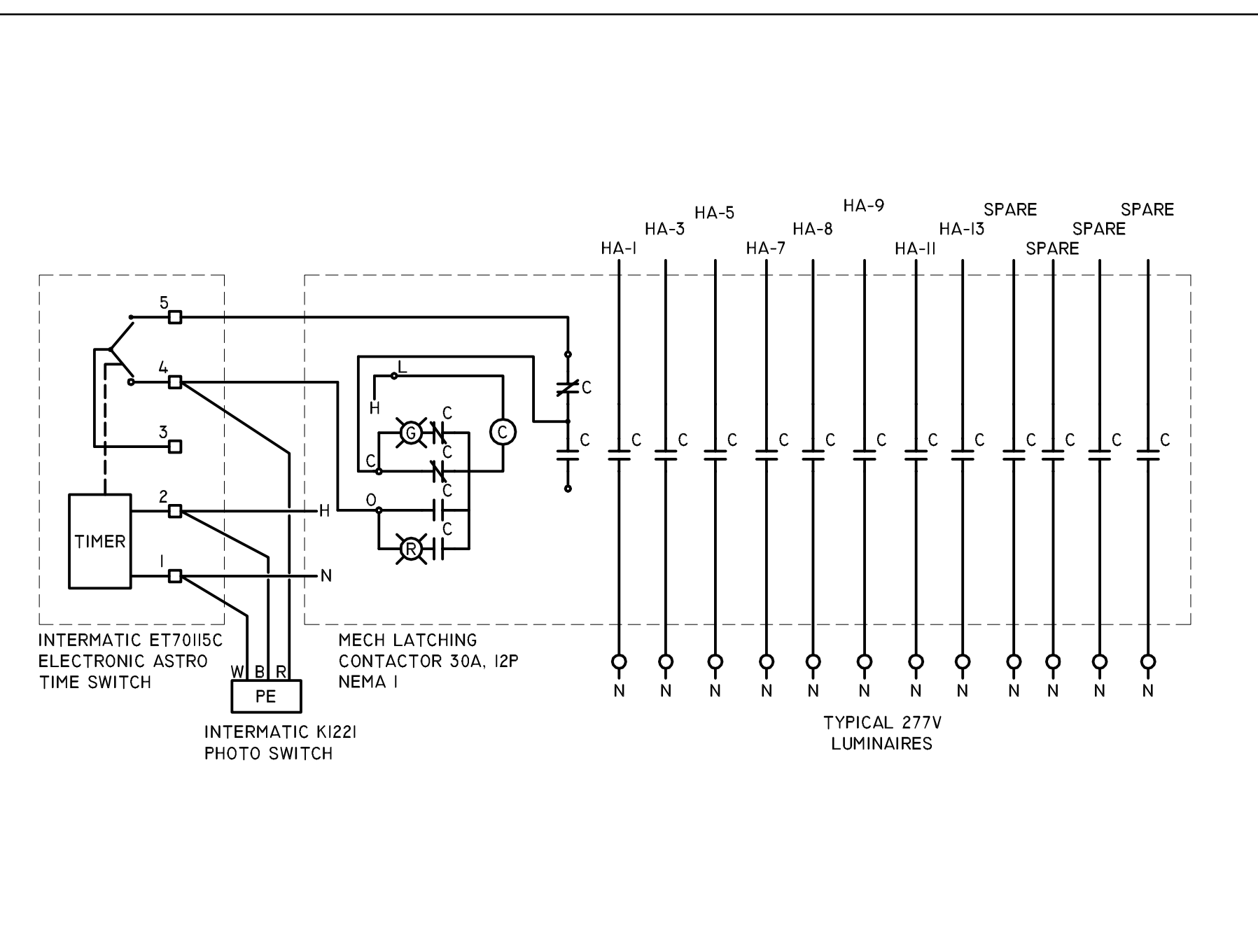
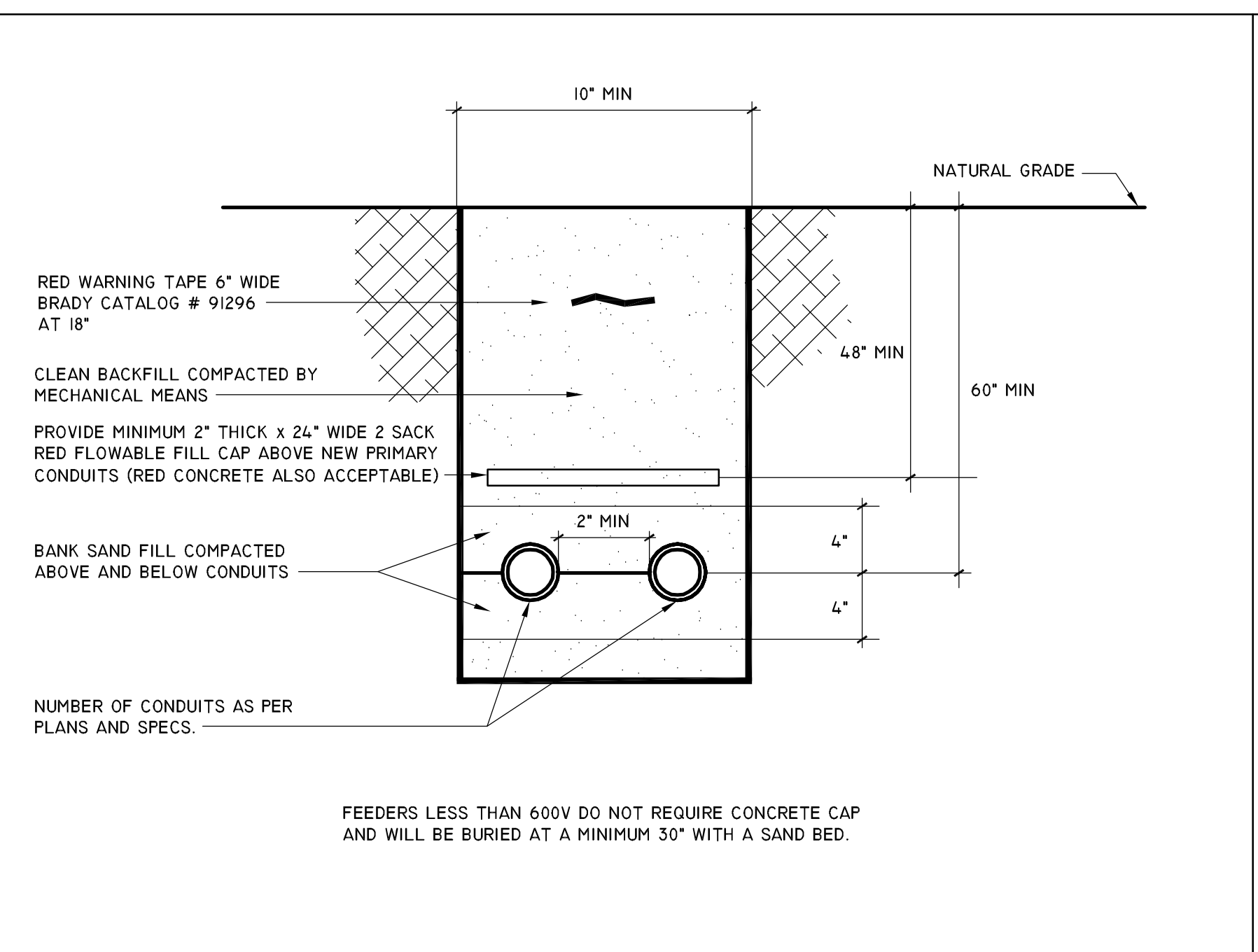

DETAIL - NOT TO SCALE 9

DETAIL - TRENCH (SERVICE FEEDERS) NOT TO SCALE 6

DETAIL - LIGHTING CONTACTOR NOT TO SCALE 3

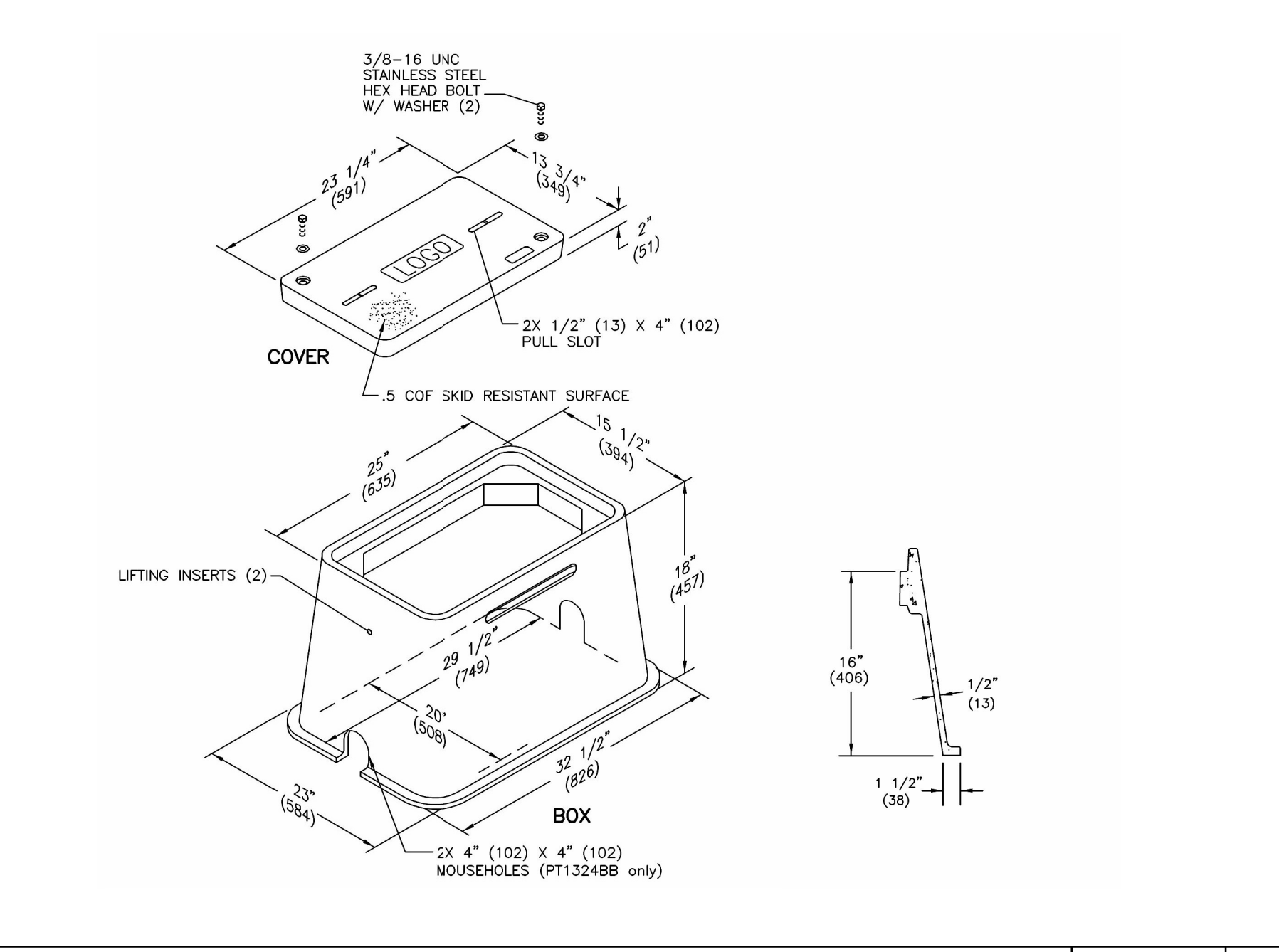
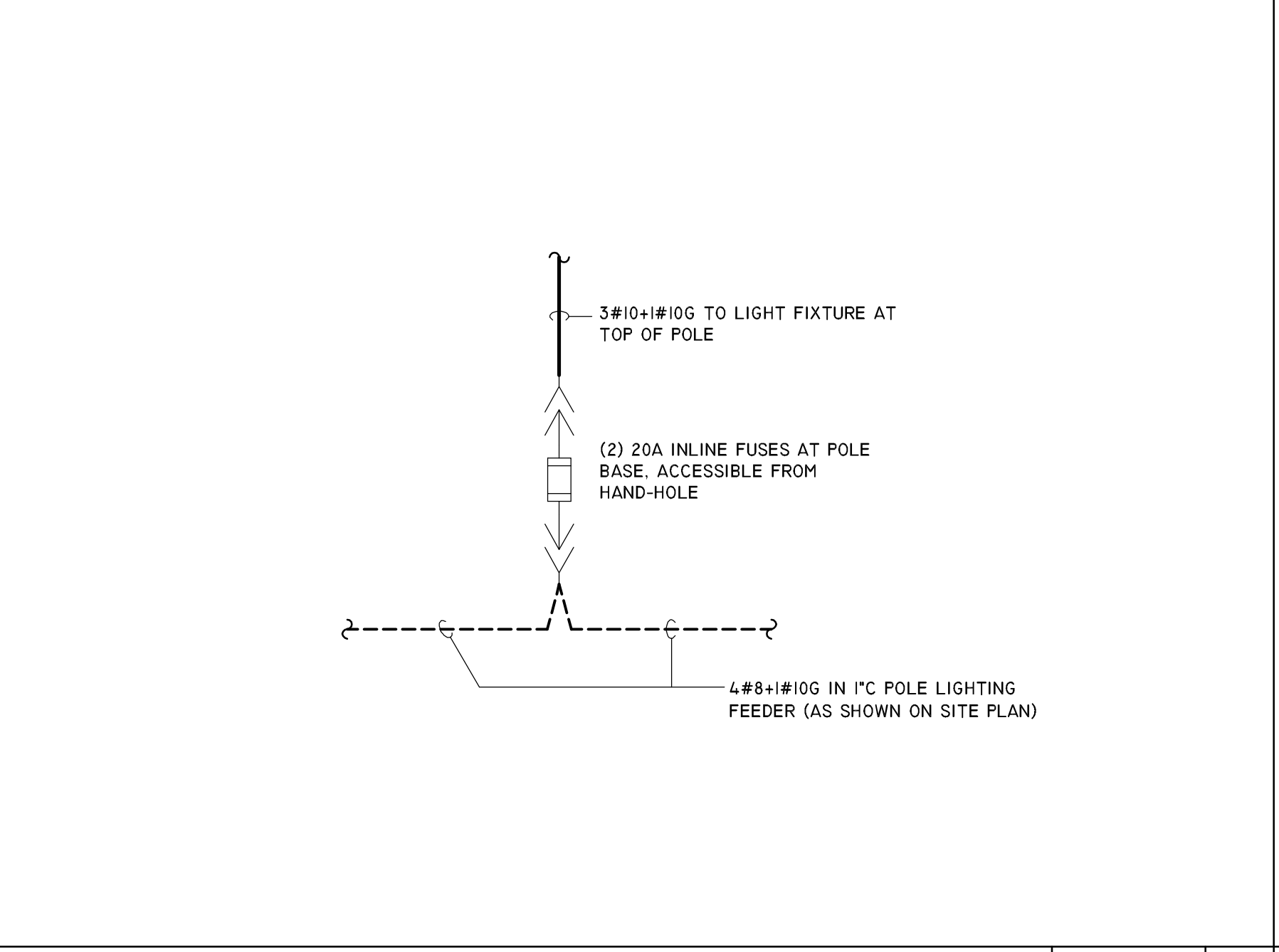

DETAIL - NOT TO SCALE 8

DETAIL - POLE LIGHT WIRING DIAGRAM AT BASE NOT TO SCALE 5

DETAIL - QUAZITE TYPE ELECTRICAL PULL BOX NOT TO SCALE 2

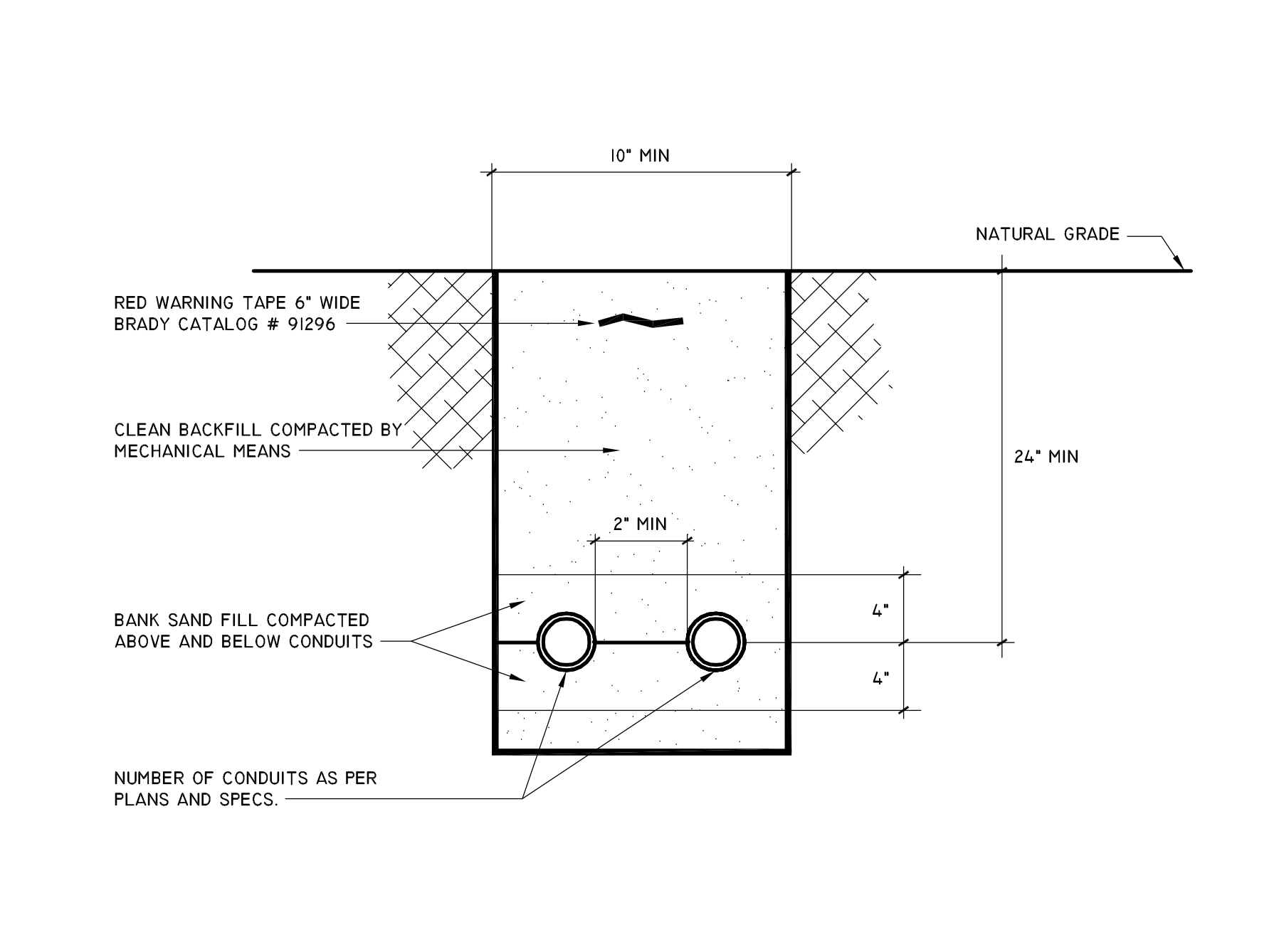
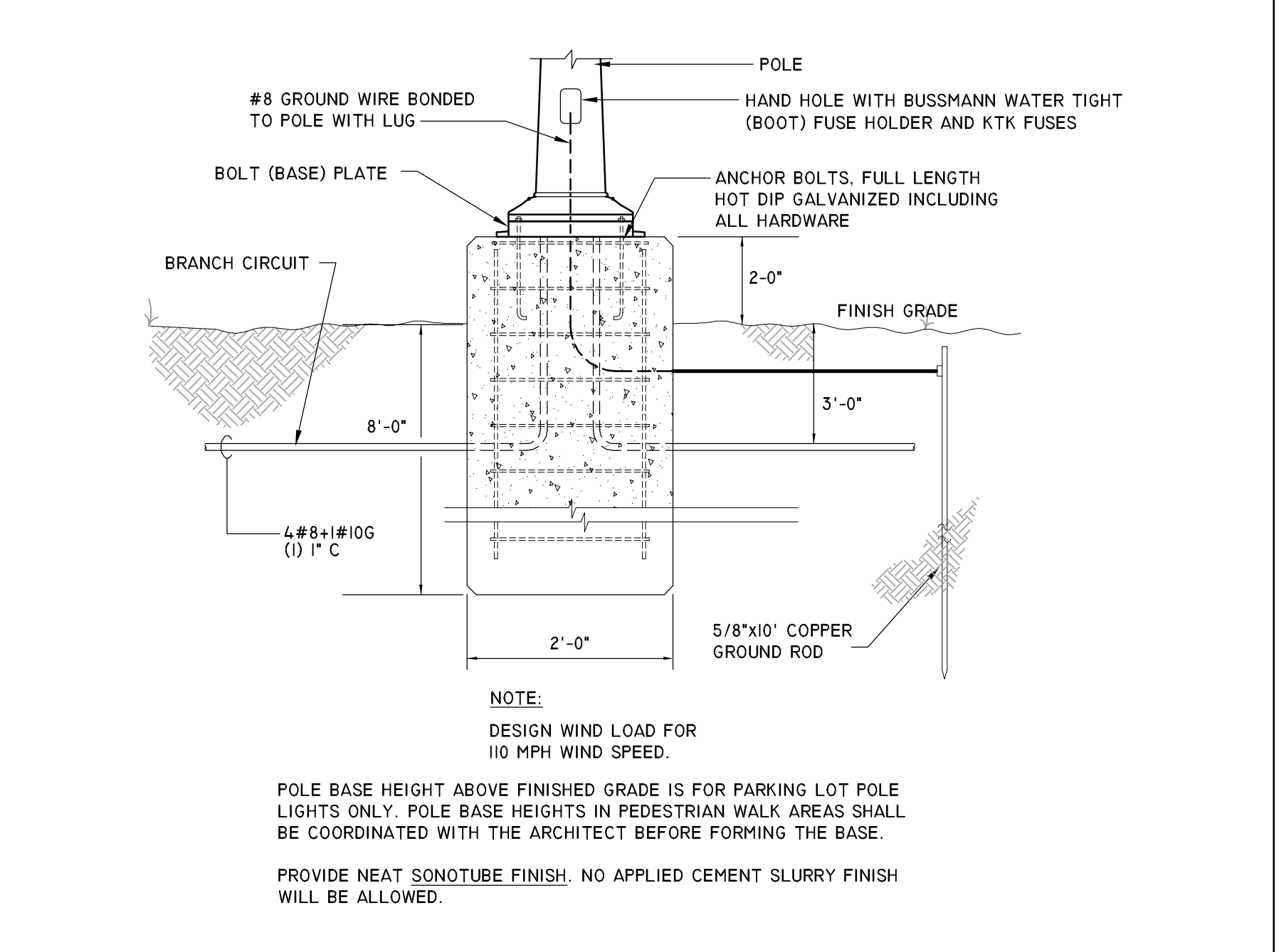

DETAIL - NOT TO SCALE 7

DETAIL - POLE BASE NOT TO SCALE 4

DETAIL - TRENCH (OTHER THAN SERVICE FEEDERS) NOT TO SCALE 1

bdg
 architecture
 + planning
 boucher design group

Boucher Design Group LLC
 Members A.I.A.
 6802 Mapleridge, Suite 200
 Bellaire, Texas 77401
 Tel. 713.785.3644
 www.bdgap.com

This document is an instrument of service
 protected by the copyright law of the United States
 of America, 17 U.S.C §102, and shall not be
 copied or reproduced without the express written
 consent of Boucher Design Group, LLC. 2016



BAYSIDE COMMUNITY CENTER
 BA CLIFF, TEXAS

GALVESTON COUNTY

DATE 02/29/16
 PROJECT NO. 1409000
 DRAWN BY OC/CJCT
 CHECKED BY WJK/DG

DETAILS

E502

© COPYRIGHT 2016 BOUCHER DESIGN GROUP, LLC

ELECTRIC WATER HEATER SCHEDULE								
MARK	MFR	MODEL	VOLTS	PHASE	KW	RECOVERY GPH @ 100°F RISE	TANK CAPACITY GALLONS	LOCATION
EW-H-1	A.O. SMITH	DEL-50	480	3	12	24	50	ABOVE MOP SINK

NOTES:
 1. OUTLET TEMPERATURE SHALL BE 140°F.
 * PROVIDE TMV LEONARD MIXING VALVE MODEL 370-LF. INLET SIZE 3/4" AND OUTLET SIZE 3/4". MIXING VALVE OUTLET SHALL BE 110°F. PROVIDE TEMP. GAUGE ON THE OUTLET PIPE. TMV SHALL COMPLY WITH ASSE 1070.

HOT WATER CIRCULATING PUMP SCHEDULE									
MARK	MFR.	MODEL NO.	TYPE	G.P.M.	HEAD	H.P.	VOLTAGE	MOTOR R.P.M.	LOCATION
HWC-P-1	BELL & GOSSETT	PL-30B	IN LINE BRONZE	8	15	1/12	120 / 1Ø	1725	MECH.

NOTES:
 1. HOT WATER CIRCULATION PUMP SHALL BE PROVIDED WITH TIMER TO DE-ENERGIZE THE PUMP UNDER DURING UNOCCUPIED PERIODS PER LATEST IEC.

PIPING MATERIALS
1. SANITARY WASTE: (BELOW GRADE) SCHEDULE 40 PVC, CONFORM TO ASTM D-1785 SOIL AND WASTE VENT PIPING. FITTINGS SHALL BE COMPATIBLE MATERIAL WITH SOLVENT CEMENT TYPE JOINTS.
2. SANITARY WASTE: (ABOVE SLAB ONLY) PIPE: CAST IRON ASTM A 74, HUBLESS, SERVICE WEIGHT. JOINTS: NO HUB. ASTM C 564 NEOPRENE GASKETS AND STANDARD STAINLESS STEEL CLAMP AND SOLID SHIELD ASSEMBLIES CONSTRUCTED OF TYPE 300 SERIES STAINLESS STEEL. CLAMP ASSEMBLIES SHALL CONFORM TO FM 1680 WHERE REQUIRED BY THE ADMINISTRATIVE AUTHORITY. FITTINGS: CAST IRON. ASTM A 888 DRAINAGE PATTERN.
3. VENT STACKS: FOR PIPING 1-1/2" AND SMALLER: PROVIDE DWV COPPER OR SCHEDULE 40 GALVANIZED PIPE AND FITTINGS. FOR PIPING 2" AND LARGER, USE CAST IRON SOIL PIPE AND FITTINGS, SAME AS ABOVE SLAB PIPING INDICATED ABOVE. PIPE MUST CONFORM TO ASTM A-74.
4. DOMESTIC WATER: TYPE "L" COPPER TUBING WITH WROUGHT COPPER FITTINGS AND 95/5 (TIN/ANTIMONY) SOLDER JOINTS.

GRADE OF HORIZONTAL DRAINAGE PIPING
1. HORIZONTAL DRAINAGE PIPING SHALL RUN IN PRACTICAL ALIGNMENT AND UNIFORM SLOPE OF NOT LESS THAN ONE-FOURTH (1/4) OF AN INCH PER FOOT OR TWO PERCENT (2) TOWARD POINT OF DISPOSAL PROVIDED THAT, WHERE IT IS IMPRACTICAL DUE TO THE DEPTH OF THE STREET SEWER OR TO THE STRUCTURAL FEATURES OR TO THE ARRANGEMENT OF ANY BUILDING OR STRUCTURE TO OBTAIN A SLOPE OF ONE-FOURTH (1/4) OF AN INCH PER FOOT OR TWO PERCENT, ANY SUCH PIPE OR PIPING FOUR (4) INCHES OR LARGER IN DIAMETER MAY HAVE A SLOPE OF NOT LESS THAN ONE EIGHTH (1/8) OF AN INCH OR ONE (1) PERCENT, WHEN FIRST APPROVED BY THE ADMINISTRATIVE AUTHORITY.

PLUMBING LEGEND	
DISREGARD LEGEND ITEMS NOT INDICATED ON DRAWINGS	
	NEW PLUMBING FIXTURE
— SAN / S —	SANITARY WASTE
— C.D. —	CONDENSATE DRAIN LINE
— V —	VENT
— GW —	GREASE WASTE
— V —	VENT
N2	NITROGEN
O2	OXYGEN
— CA —	COMPRESSED AIR
— DCW —	DOMESTIC COLD WATER PIPING
— DHW —	DOMESTIC HOT WATER PIPING
— DHWR —	DOMESTIC HOT WATER RETURN PIPING
— NG —	NATURAL GAS
FCO	FLOOR CLEAN OUT
ECO	EXTERIOR CLEANOUT
WCO	WALL CLEANOUT
FD	FLOOR DRAIN
FS	FLOOR SINK
	RISER IDENTIFICATION
	ELBOW UP
	ELBOW DOWN
	BALL VALVE
B.V.	BALANCING VALVE
	GAS VALVE
	GATE VALVE
	GLOBE VALVE
	CHECK VALVE
	CAP AND SEAL
VTR	VENT THROUGH ROOF
(E)	EXISTING

PLUMBING FIXTURE SCHEDULE									
MARK	DESCRIPTION	SIZE OF CONNECTION					REMARKS		
		TRAP	SS	SV	CW	HW			
SK-1	HAND SINK (KITCHEN)	1 1/2"	3"	2"	1/2"	1/2"	7-PS-7J ADVANCE TABCO, WALL MOUNTED HAND SINK, SINGLE FAUCET HOLE, ONE PIECE DEEP DRAWN SINK BOWL. (10"WX14"LX8"D). KEYHOLE WALL MOUNT BRACKET, STAINLESS STEEL BASKET DRAIN 1 1/2"IPS.		
							116.104.AB.1 CHICAGO FAUCETS, SINGLE HOLE. GN2AH8AB - 5-1/4" RIGID / SWING GOOSENECK SPOUT. E2805-5AB - 0.5 GPM VANDAL PROOF NON-AERATING SPRAY OUTLET, SINGLE SUPPLY FOR TEMPERED WATER. 12 VOLT AC TRANSFORMER REQUIRED (ORDER SEPARATELY). STAINLESS STEEL HOSE INCLUDED. MULTIPLE FIELD ADJUSTABLE MODES AND RANGES, COMPATIBLE WITH CHICAGO FAUCETS COMMANDER® HANDHELD PROGRAMMING UNIT. CHROME PLATE FINISH. WEIGHT: 5.123LBS. ECAS™ CONSTRUCTION WITH EQUAL TO OR LESS THAN 0.25% LEAD CONTENT BY WEIGHT AVERAGE PROVIDE WITH HARDWIRE TRANSFORMER 240.631.00.1 CHICAGO FAUCETS. PROVIDE TMV-1.		
							BV02 MCGUIRE'S, 1/2 IPS X 3/8 OD, QUARTER-TURN BRASS BALL VALVE ANGLE STOP, CHROME PLATED, CONVERTIBLE LOOSE KEY HANDLE. SUPPLY STOP VALVE SHALL BE CERTIFIED BY CSA OR OTHER RECOGNIZED TESTING AUTHORITY AND SHALL BEAR MANUFACTURER AND TESTING MARK. STOP TO BE CERTIFIED TO 200 PSI LINE PRESSURE.		
							8872 MCGUIRE, HEAVY CAST BRASS 1 1/4 X 1 1/4 ADJUSTABLE TRAP WITH CLEANOUT PLUG AND 1/16" CENTER TO END. FURNISHED WITH SLIP NUTS, 17 GAUGE SEAMLESS TUBULAR BRASS WALL BEND, AND STEEL SHALLOW FLANGE.		
							270-LF LEONARD, LEAD FREE BRONZE BODY, ECO-MIX, LOCKED TEMPERATURE ADJUSTMENT CAP (VANDAL RESISTANT), COPPER ENCAPSULATED THERMOSTAT ASSEMBLY WITH POLYMER THERMOPLASTIC SHUTTLE, STAINLESS STEEL SPRINGS, BUNA-N O-RINGS, INTEGRAL CHECK VALVES ON HOT AND COLD INLETS. SET OUTLET TEMPERATURE TO 105°F.		
TMV-1	THERMOSTATIC MIXING VALVE	-	-	-	1/2"	1/2"	LF-270 LEONARD, THERMOSTATIC MIXING VALVE, COMPLY WITH ASSE 1070, LEAD FREE BRONZE BODY, LOCKED TEMPERATURE ADJUSTMENT CAP (VANDAL RESISTANT), COPPER ENCAPSULATED THERMOSTAT ASSEMBLY WITH POLYMER THERMOPLASTIC SHUTTLE, STAINLESS STEEL SPRINGS, BUNA-N O-RINGS, INTEGRAL CHECK VALVES ON HOT AND COLD INLET. OUTLET OF THE TMV SHALL BE 105°F.		
MS-1	MOP SINK (FLOOR MOUNTED)	3"	3"	2"	3/4"	3/4"	HL-1800 STERN WILLIAMS HILOW, 24"X24"X12" DRAIN SHALL CAST BRASS WITH STAINLESS STEEL STRAINER CAST INTEGRAL AND SHALL PROVIDE FOR CALLED LEAD CONNECTION NOT LES THAN 1" DEEP TO A 3" PIPE TERRAZZO RECEPTOR COMPOSED OF PEARL GREY MARBLE CHIPS AND WHITE PORTLAND CEMENT GROUND SMOOTH, GROUTED AND SEALED TO RESIST STAINS. STAINLESS STEEL CAP OF ONE PIECE 20 GA. 302 STAINLESS STEEL CAST INTEGRAL ON FROM DROP.		
							540-L08975HXFCP CHICAGO FAUCETS, 8" FIXED CENTERS, 897-SJKCP - 5 3/4" RIGID VACUUM BREAKER SPOUT WITH 3/4" MALE HOSE THREAD AND PAIL HOOK, 369-PR - 2 3/8" LEVER HANDLE, XT - QUARTER COMPRESSION OPERATING CARTRIDGE, WXF - STRAIGHT 2" INLET SUPPLY ARM WITH WALL FLANGE WITH 1/2" NPT FEMALE THREAD INLET, ATMOSPHERIC VACUUM BREAKER, NOT INTENDED FOR CONTINUOUS PRESSURE APPLICATIONS, CHROME PLATE FINISH.		
							T-35 STERN WILLIAMS, HOSE AND WALL HOOK, HOSE 36" LONG, WITH 3/4" CHROME COUPLINGS, WALL BRACKET OF STAINLESS STEEL.		
							T-40 STERN WILLIAMS, STAINLESS STEEL MOP HANGER OF STAINLESS STEEL WITH #4 FINISH, 24" LONG, WITH 3 RUBBER SPRING LOADED GRIPS.		
							BP STERN WILLIAMS, SPLASH CATCHER PANELS OF 20 GA. TYPE 304 STAINLESS STEEL.		
EDF-1	ELECTRIC DRINKING FOUNTAIN (BI-LEVEL) (A.D.A.)	1 1/2"	2"	2"	1/2"	-	H7HB-HVRGN8BL-WF HALSEY TAYLOR, UNIT SHALL INCLUDE A BI-LEVEL WATER COOLER WITH A BOTTLE FILLING STATION, ONE-PIECE CHROME-PLATED VANDAL-RESISTANT WATER CONSERVATION BUBBLER WITH INTEGRAL HOOD. UNITS SHALL HAVE A HIGH-EFFICIENCY REFRIGERATION SYSTEM AND DELIVER GPH OF 50°F DRINKING WATER AT 90°F AMBIENT AIR AND 80°F INLET WATER. LOWER UNITS SHALL HAVE MECHANICALLY ACTIVATED PUSHBUTTON ACTIVATION. BOTTLE FILLER SHALL INCLUDE ELECTRONIC SENSOR FOR NO-TOUCH ACTIVATION WITH AUTOMATIC 20-SECOND SHUT-OFF TIMER. SHALL INCLUDE A GREEN COUNTER DISPLAYING THE COUNT OF PLASTIC BOTTLES SAVED FROM THE LANDFILL. SHALL INCLUDE THE WATERSENTRY® PLUS 3000-GALLON FILTER, CERTIFIED TO NSF/ANSI 42 FOR CHLORINE-CLASS I, PARTICULATE-CLASS I AND TASTE AND ODOR AND NSF/ANSI 53 FOR LEAD REDUCTION. WILL VISUAL MONITOR FILTER TO INDICATE WHEN FILTER MAINTENANCE IS REQUIRED. SHALL PROVIDE 1.1 GPM WITH LAMINAR FLOW TO MINIMIZE SPLASHING. SHALL INCLUDE ANTI-MICROBIAL PROTECTED PLASTIC COMPONENTS TO PREVENT MOLD AND MILDEW. COOLER SHALL HAVE STAINLESS STEEL CABINET AND BASIN. COOLER SHALL INCLUDE REMOVABLE DRAIN STRAINER. SHALL COMPLY WITH ADA GUIDELINES FOR VISUAL AND MOTION DISABILITIES. THE MANUFACTURER SHALL CERTIFY THE UNIT TO MEET THE REQUIREMENTS OF NSF/ANSI 61 AND 372, UL 399 AND CAN/CSA 22.2 NO. 120.		
							BV02 MCGUIRE, 1/2 IPS X 3/8 OD, QUARTER-TURN BRASS BALL VALVE ANGLE STOP, CHROME PLATED, CONVERTIBLE LOOSE KEY HANDLE. SUPPLY STOP VALVE SHALL BE CERTIFIED BY CSA OR OTHER RECOGNIZED TESTING AUTHORITY AND SHALL BEAR MANUFACTURER AND TESTING MARK. STOP TO BE CERTIFIED TO 200 PSI LINE PRESSURE.		
							42522 HALSEY TAYLOR, STAINLESS STEEL APRON, PROVIDE APRON ONLY FOR UNITS MOUNTED AT NON-ADA HEIGHT TO MEET A.D.A. REQUIREMENTS OF 24" A.F.F.		
							MLP100 HALSEY TAYLOR, IN WALL CARRIER MOUNTING SYSTEM.		
							8872 MCGUIRE, HEAVY CAST BRASS 1 1/4 X 1 1/4 ADJUSTABLE TRAP WITH CLEANOUT PLUG AND 1/16" CENTER TO END. FURNISHED WITH SLIP NUTS, 17 GAUGE SEAMLESS TUBULAR BRASS WALL BEND, AND STEEL SHALLOW FLANGE.		
FCO-1	FLOOR CLEANOUT	-	-	-	-	-	2060 J.R. SMITH, WITH SCREWED PLUG AND FLASHING RING AND COVER PLATE WITH SECURING SCREW. COVER PLATE SHALL BE FLUSH TO FINISH FLOOR, AND SUITABLE FOR FLOOR COVERING INSTALLED.		
ECO-1	EXTERIOR CLEANOUT	-	-	-	-	-	4250 J.R. SMITH, ALL EXTERIOR CLEANOUTS SHALL BE SET AT FINISHED GRADE IN 6 INCH THICK CONCRETE PAD FINISHED SMOOTH ON TOP. HOUSING SHALL BE COMPLETELY FREE OF PIPING SO NO LOADING IS TRANSMITTED TO THE PIPE.		
WCO-1	WALL CLEANOUT	-	4"	2"	-	-	4435 J.R. SMITH, WITH SCREWED PLUG AND FLASHING RING AND COVER PLATE WITH SECURING SCREW. COVER PLATE SHALL BE FLUSH TO FINISH WALL. COORDINATE WITH ARCHITECTURAL DRAWINGS FOR CASEWORK LOCATIONS. COVER PLATE SHALL THEN BE FLUSHED WITH CASE WORK'S FINISH BACK WALL.		
FS-1	FLOOR SINK	3"-4"	3"	2"	-	-	2415C-LSG J.R. SMITH, 1/2 TOP GRATE, INDIRECT WASTE FLOOR SINK, DUCO CAST IRON BODY, LOOSE GRATE WITH SEDIMENT BUCKET 12"x12"SQ. - 10" DEEP. FURNISH AND INSTALL WITH DEEP SEAL P-TRAP ASSEMBLY. INSTALL COMPLETE WITH PROSET TRAP GUARD.		
FD-1	FLOOR DRAIN	3"	3"	2"	-	-	2010C-A. J.R. SMITH, DUCO CAST IRON BODY WITH FLASHING COLLAR AND ADJUSTABLE STRAINER HEAD 6" DIAMETER TYPE "A" NICKEL BRONZE STRAINER. INSTALL COMPLETE WITH PROSET TRAP GUARD, EXCEPT FOR SHOWER DRAIN.		

PLUMBING FIXTURE SCHEDULE									
MARK	DESCRIPTION	SIZE OF CONNECTION					REMARKS		
		TRAP	SS	SV	CW	HW			
WC-1	WATER CLOSET (FLOOR MOUNTED)	-	4"	2"	1"	-	2234.001 AMERICAN STANDARD "MADERA", FLOOR MOUNTED, 12" ROUGHING-IN, 14"HIGH, ELONGATED BOWL, WITH 1-1/2 INCH INLET TOP SPUD, 1.28 GPF SLOAN ROYAL FLUSH VALVE WITH VACUUM BREAKER, AND 1-INCH SCREWDRIVER ANGLE STOP.		
							1111-1.28 SLOAN "ROYAL", SYNTHETIC RUBBER DIAPHRAGM WITH DUAL FILTERED FIXED BYPASS, ADA COMPLIANT METAL OSCILLATING NON-HOLD-OPEN HANDLE WITH TRIPLE SEAL HANDLE PACKING, 1" I.P.S. SCREWDRIVER BAK-CHEK® ANGLE STOP WITH FREE SPINNING VANDAL RESISTANT STOP CAP, ADJUSTABLE TAILPIECE, HIGH BACK PRESSURE VACUUM BREAKER FLUSH CONNECTION WITH ONE-PIECE BOTTOM HEX COUPLING NUT, SPUD COUPLING AND FLANGE FOR 1-1/2" TOP SPUD, SWEAT SOLDER ADAPTER W/COVER TUBE & CAST WALL FLANGE W/SET SCREW, HIGH COPPER, LOW ZINC BRASS CASTINGS FOR DEZINCIFICATION RESISTANCE, NON-HOLD-OPEN HANDLE, FIXED METERING BYPASS AND NO EXTERNAL VOLUME ADJUSTMENT TO ENSURE WATER CONSERVATION, FLUSH ACCURACY CONTROLLED BY CID TECHNOLOGY, DIAPHRAGM, HANDLE PACKING, STOP SEAT AND VACUUM BREAKER MOLDED FROM PERMEX RUBBER COMPOUND FOR CHLORAMINE RESISTANCE.		
							9500C CHURCH, ELONGATED SEAT, OPEN FRONT LESS COVER, SOLID PLASTIC, CONCEALED CHECK STAINLESS STEEL HINGES.		
WC-2	WATER CLOSET (FLOOR MOUNTED) (A.D.A.)	-	4"	2"	1"	-	34.61.001 AMERICAN STANDARD "MADERA", FLOOR MOUNTED, 12" ROUGHING-IN, ADA 17" ELONGATED BOWL, WITH 1-1/2 INCH INLET SPUD, 1.28 GPF.		
							1111-1.28 SLOAN "ROYAL", SYNTHETIC RUBBER DIAPHRAGM WITH DUAL FILTERED FIXED BYPASS, ADA COMPLIANT METAL OSCILLATING NON-HOLD-OPEN HANDLE WITH TRIPLE SEAL HANDLE PACKING, 1" I.P.S. SCREWDRIVER BAK-CHEK® ANGLE STOP WITH FREE SPINNING VANDAL RESISTANT STOP CAP, ADJUSTABLE TAILPIECE, HIGH BACK PRESSURE VACUUM BREAKER FLUSH CONNECTION WITH ONE-PIECE BOTTOM HEX COUPLING NUT, SPUD COUPLING AND FLANGE FOR 1-1/2" TOP SPUD, SWEAT SOLDER ADAPTER W/COVER TUBE & CAST WALL FLANGE W/SET SCREW, HIGH COPPER, LOW ZINC BRASS CASTINGS FOR DEZINCIFICATION RESISTANCE, NON-HOLD-OPEN HANDLE, FIXED METERING BYPASS AND NO EXTERNAL VOLUME ADJUSTMENT TO ENSURE WATER CONSERVATION, FLUSH ACCURACY CONTROLLED BY CID TECHNOLOGY, DIAPHRAGM, HANDLE PACKING, STOP SEAT AND VACUUM BREAKER MOLDED FROM PERMEX RUBBER COMPOUND FOR CHLORAMINE RESISTANCE.		
							9500C CHURCH, ELONGATED SEAT, OPEN FRONT LESS COVER, SOLID PLASTIC, CONCEALED CHECK STAINLESS STEEL HINGES.		
							WATER CLOSET RIM HEIGHT SHALL BE 17" ABOVE FINISHED FLOOR LEVEL PER A.D.A. REQUIREMENTS.		
U-1	URINAL	3"	2"	2"	3/4"	-	6590.001 AMERICAN STANDARD "WASHBROOK", OPERATES IN THE RANGE OF 0.5 GPF. FLUSHING RIM, ELONGATED 14" RIM FROM FINISHED WALL, WASHOUT FLUSH ACTION, EXTENDED SIDES FOR PRIVACY, 3/4" INCH INLET SPUD, OUTLET CONNECTION REARED 2" INSIDE (NPTF), STRAINER INCLUDED, MEETS ASME FLUSH REQUIREMENTS AT 0.5 GPF.		
							186-0.5 SLOAN "ROYAL", 0.5. DUAL FILTERED FIXED BYPASS DIAPHRAGM, ADA COMPLIANT METAL OSCILLATING NON-HOLD-OPEN HANDLE WITH TRIPLE SEAL HANDLE PACKING, 3/4" I.P.S. SCREWDRIVER BAK-CHEK® ANGLE STOP W/ FREE SPINNING VANDAL RESISTANT STOP CAP, ADJUSTABLE TAILPIECE, HIGH BACK PRESSURE VACUUM BREAKER FLUSH CONNECTION W/ ONE-PIECE BOTTOM HEX COUPLING NUT, SPUD COUPLING AND FLANGE FOR 3/4" TOP SPUD, SWEAT SOLDER ADAPTER W/COVER TUBE & CAST WALL FLANGE W/SET SCREW, HIGH COPPER, LOW ZINC BRASS CASTINGS FOR DEZINCIFICATION RESISTANCE, NON-HOLD-OPEN HANDLE, FIXED METERING BYPASS AND NO EXTERNAL VOLUME ADJUSTMENT TO ENSURE WATER CONSERVATION, FLUSH ACCURACY CONTROLLED BY CID TECHNOLOGY, DIAPHRAGM, HANDLE PACKING, STOP SEAT AND VACUUM BREAKER MOLDED FROM PERMEX SYNTHETIC RUBBER COMPOUND FOR CHLORAMINE RESISTANCE.		
							0611 SERES J.R. SMITH, CONCEALED CHAIR CARRIER WITH BEARING PLATE OR APPROVED EQUAL.		
							URINAL RIM HEIGHT SHALL BE 24" ABOVE FINISHED FLOOR LEVEL.		
L-1	LAVATORY (UNDER COUNTER MOUNTED) (A.D.A.)	1 1/4"	2"	2"	1/2"	1/2"	0495.221 AMERICAN STANDARD "OVALYN", UNDER COUNTER LAVATORY, VITREOUS CHINA, SINGLE HOLE CENTER MOUNTING.		
							116.706.21.1 CHICAGO FAUCET, ELECTRONIC FAUCET, E-TRONIC 40 DECK MOUNTED 4" CENTERSET LAVATORY FAUCET - AC POWER, POLISHED CHROME PLATED FINISH, EFFICIENT DUAL BEAM INFRARED SENSORS, METAL SPOUT CONSTRUCTION, 4" C-C INTEGRAL BODY DESIGNED FOR 4" MOUNTING INSTALLATION, .5 GPM (1.9 L/MIN) VANDAL RESISTANT SPRAY OUTLET, CATALOG #E2805, MULTIPLE FIELD ADJUSTABLE MODES AND RANGES, SINGLE SUPPLY FOR TEMPERED WATER, ABOVE DECK HERMETICALLY SEALED ELECTRONICS, ABOVE DECK WATER-TIGHT SOLENOID WITH FILTER SCREEN, 1/2" NPSM BRASS SHANK WITH FILTER SCREEN, GEBERIT COMMANDER SOFTWARE COMPATIBLE, MOUNTING HARDWARE INCLUDED, 12 VOLT AC TRANSFORMER REQUIRED (240.631.00.1 CHICAGO FAUCETS). PROVIDE TMV-1.		
							HD155WC MCGUIRE, WHEELCHAIR LAVATORY STRAINER, FURNISHED WITH HEAVY CAST BRASS GRID DRAIN STRAINER, ELBOW AND 1 1/4" 17GA SEAMLESS TUBULAR OFFSET TAILPIECE. PVD CHROME FINISH. ADA COMPLIANT. 8 3/4" X 5 1/8" OD.		
							BV02 MCGUIRE'S, 1/2 IPS X 3/8 OD, QUARTER-TURN BRASS BALL VALVE ANGLE STOP, CHROME PLATED, CONVERTIBLE LOOSE KEY HANDLE. SUPPLY STOP VALVE SHALL BE CERTIFIED BY CSA OR OTHER RECOGNIZED TESTING AUTHORITY AND SHALL BEAR MANUFACTURER AND TESTING MARK. STOP TO BE CERTIFIED TO 200 PSI LINE PRESSURE.		
							8872 MCGUIRE, HEAVY CAST BRASS 1 1/4 X 1 1/4 ADJUSTABLE TRAP WITH CLEANOUT PLUG AND 1/16" CENTER TO END. FURNISHED WITH SLIP NUTS, 17 GAUGE SEAMLESS TUBULAR BRASS WALL BEND, AND STEEL SHALLOW FLANGE.		
L-2	LAVATORY (WALL MOUNTED) (A.D.A.)	1 1/4"	2"	2"	1/2"	-	0355.012 AMERICAN STANDARD "LUCERNE", WALL HUNG LAVATORY, BARRIER FREE, VITREOUS CHINA, SELF-DRAINING DECK AREA WITH CONTOURED BACK AND SIDE SPLASH SHIELDS, 3 HOLES 4" CENTER.		
							116.706.21.1 CHICAGO FAUCET, ELECTRONIC FAUCET, E-TRONIC 40 DECK MOUNTED 4" CENTERSET LAVATORY FAUCET - AC POWER, POLISHED CHROME PLATED FINISH, EFFICIENT DUAL BEAM INFRARED SENSORS, METAL SPOUT CONSTRUCTION, 4" C-C INTEGRAL BODY DESIGNED FOR 4" MOUNTING INSTALLATION, .5 GPM (1.9 L/MIN) VANDAL RESISTANT SPRAY OUTLET, CATALOG #E2805, MULTIPLE FIELD ADJUSTABLE MODES AND RANGES, SINGLE SUPPLY FOR TEMPERED WATER, ABOVE DECK HERMETICALLY SEALED ELECTRONICS, ABOVE DECK WATER-TIGHT SOLENOID WITH FILTER SCREEN, 1/2" NPSM BRASS SHANK WITH FILTER SCREEN, GEBERIT COMMANDER SOFTWARE COMPATIBLE, MOUNTING HARDWARE INCLUDED, 12 VOLT AC TRANSFORMER REQUIRED (240.631.00.1 CHICAGO FAUCETS). PROVIDE TMV-1.		
							BV02 MCGUIRE, 1/2 IPS X 3/8 OD, QUARTER-TURN BRASS BALL VALVE ANGLE STOP, CHROME PLATED, CONVERTIBLE LOOSE KEY HANDLE. SUPPLY STOP VALVE SHALL BE CERTIFIED BY CSA OR OTHER RECOGNIZED TESTING AUTHORITY AND SHALL BEAR MANUFACTURER AND TESTING MARK. STOP TO BE CERTIFIED TO 200 PSI LINE PRESSURE.		
							149 MCGUIRE, FLAT GRID STRAINER WITH 4" TAILPIECE. WROUGHT BRASS SINK STRAINER WITH 20 GA TAILPIECE AND BRASS LOCK AND COUPLING NUTS. FITS SINK DEPTH UP TO 3/4". CHROME PLATED.		
							8872 MCGUIRE, HEAVY CAST BRASS 1 1/4 X 1 1/4 ADJUSTABLE TRAP WITH CLEANOUT PLUG AND 1/16" CENTER TO END. FURNISHED WITH SLIP NUTS, 17 GAUGE SEAMLESS TUBULAR BRASS WALL BEND, AND STEEL SHALLOW FLANGE.		
							102-EZ-W TRUEBRO, "P" TRAP AND SUPPLY INSULATION KIT.		
							0700 J.R. SMITH, LAVATORY SUPPORTS WITH CONCEALED ARMS.		
WH-1	WALL HYDRANT (FREEZE POOF)	-	-	-	3/4"	-	5519 J.R. SMITH, BRONZE QUARTER TURN NON-FREEZE AUTOMATIC DRAINING HYDRANT WITH STAINLESS STEEL FACE, HOSE CONNECTION, INTEGRAL VACUUM BREAKER AND DUAL CHECK VALVE. "T" HANDLE KEY, WHEEL HANDLE AND STAINLESS STEEL BOX WITH FULL 180° COVER OPENING.		

ISSUE #	DATE	DESCRIPTION
1	02/29/2016	100% CD
2	05/12/2016	VE Changes

Infrastructure Associates
 INFRASTRUCTURE ASSOCIATES, INC.
 617 RICHMOND AVENUE, SUITE 200
 HOUSTON, TEXAS 77057
 TFP# REGISTRATION NO. F-4506
 (713) 622-0120 PH (713) 622-0557 FAX
 WWW.IAHOUSTON.COM

bdg
architecture + planning
 boucher design group

Boucher Design Group LLC
 Members A.I.A.
 6802 Maple Ridge, Suite 200
 Bellaire, Texas 77401
 Tel. 713.785.3644
 www.bdgap.com

This document is an instrument of service protected by the copyright law of the United States of America, 17 U.S.C §102, and shall not be copied or reproduced without the express written consent of Boucher Design Group, LLC. 2016



BAYSIDE COMMUNITY CENTER
 BACLIFF, TEXAS
GALVESTON COUNTY

DATE	02/29/16
PROJECT NO.	1409000
DRAWN BY	OC/CJCT
CHECKED BY	WJK/DG

SCHEDULES, NOTES, AND LEGEND

P101
 © COPYRIGHT 2016 BOUCHER DESIGN GROUP, LLC

ISSUE #	DATE	DESCRIPTION
0	02/29/2016	100% CD
1	05/12/2016	VE Changes

Infrastructure Associates
 INFRASTRUCTURE ASSOCIATES, INC.
 617 RICHMOND AVENUE, SUITE 200
 HOUSTON, TEXAS 77002
 TBP# REGISTRATION NO. F-4566
 (713) 622-0120 PH (713) 622-0557 FAX
 WWW.IAHOUSTON.COM

GENERAL NOTE:

- ALL VENTS BELOW FINISHED FLOOR FORM FLOOR DRAINS, FLOOR SINKS AND ETC. EACH LINE SHALL BE PIPED SEPARATELY TO NEAREST WALL CAVITY. VENT LINES SHALL NOT BE COMBINED BELOW SLAB.

KEYED NOTE:

- EWH-1 SUSPENDED FROM STRUCTURE AT HIGHEST LEVEL POSSIBLE. PROVIDE AUXILIARY DRAIN PAN BELOW WATER HEATER. ROUTE T&P AND ALX. DRAIN LINES TO FLOOR SINK IN THIS ROOM. PROVIDE ADEQUATE SUPPORTS TO PREVENT ANY MOVEMENT OF DRAIN LINES. DRAIN LINES SHALL ROUTE TO FLOOR SINK WITH A 1" AIR GAP.

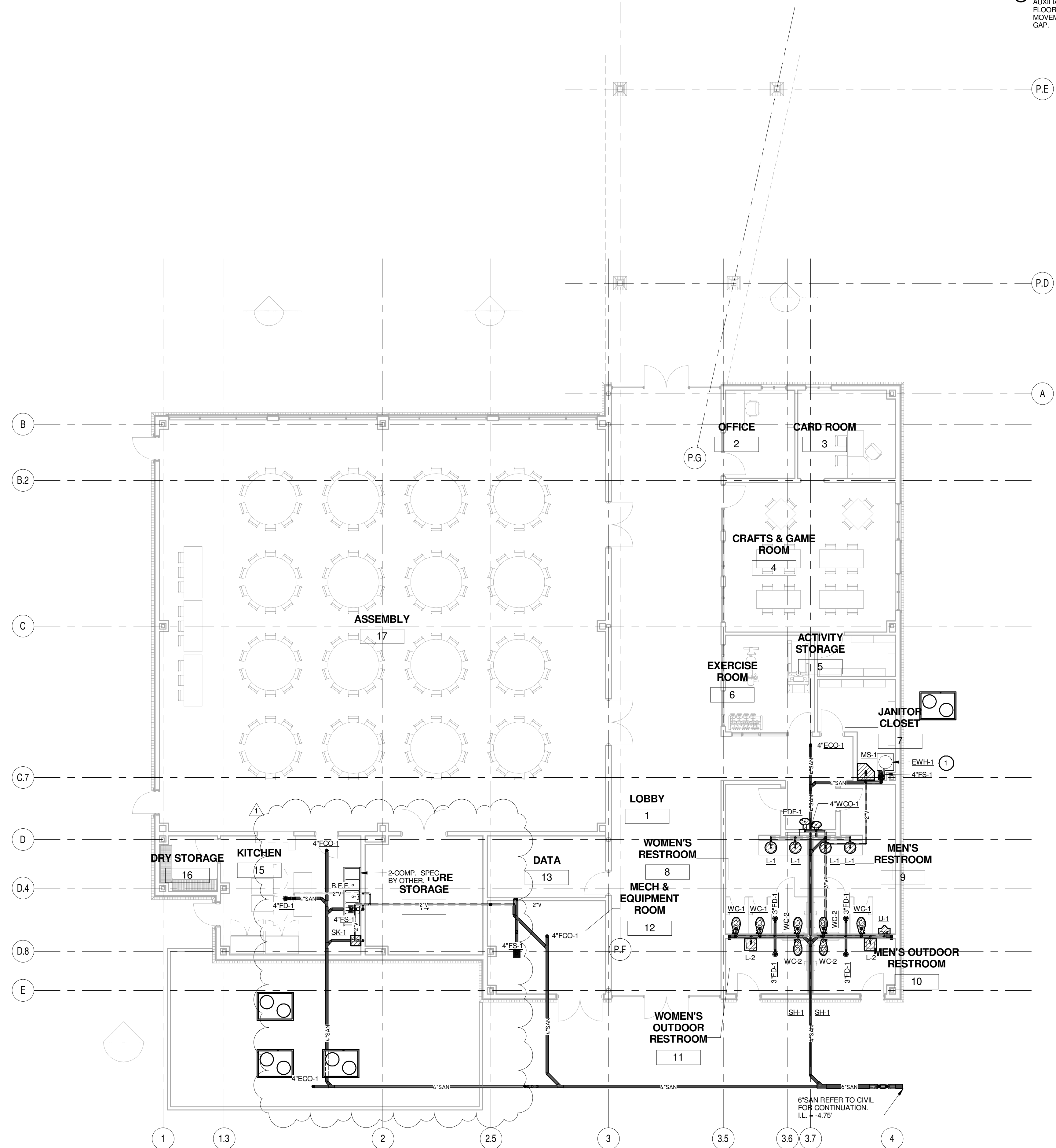

1 SANITARY FLOOR PLAN
 1/8" = 1'-0"

bdg
 architecture
 + planning
 boucher design group

Boucher Design Group LLC
 Members A.I.A.
 6802 Mapleridge, Suite 200
 Bellaire, Texas 77401
 Tel. 713.785.3644
 www.bdgap.com

This document is an instrument of service protected by the copyright law of the United States of America, 17 U.S.C §102, and shall not be copied or reproduced without the express written consent of Boucher Design Group, LLC. 2016

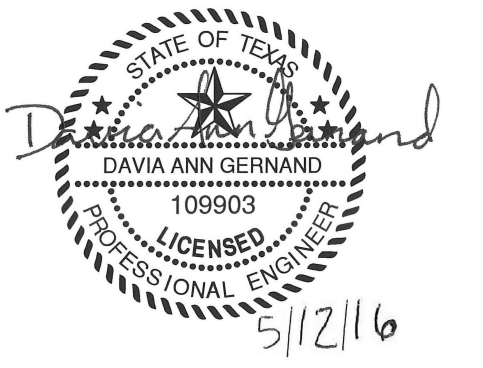

BAYSIDE COMMUNITY CENTER	
BACLIFF, TEXAS	
GALVESTON COUNTY	
DATE	02/29/16
PROJECT NO.	1409000
DRAWN BY	OC/CJ/CT
CHECKED BY	WJK/DG

PLUMBING FLOOR PLAN - SANITARY

P201

C:\Users\davag\Documents\Galveston Community Center - MEP - R2015_Davag.rvt
5/19/2016 10:25:37 AM

GENERAL NOTE:

1. ALL COLD WATER PIPING AND STORM DRAINAGE PIPING SHALL BE INSULATED WITH 1" FIBERGLASS INSULATION. ALL HOT AND HOT WATER RETURN PIPING SHALL BE INSULATED AS FOLLOWS (1 1/4" AND BELOW 1" FIBERGLASS INSULATION SHALL BE USED) AND (1 1/2" AND ABOVE 2" FIBERGLASS INSULATION SHALL BE USED)

KEYED NOTE:

1. EWH-1 SUSPENDED FROM STRUCTURE AT HIGHEST LEVEL POSSIBLE. PROVIDE AUXILIARY DRAIN PAN BELOW WATER HEATER. ROUTE T&P AND AUX. DRAIN LINES TO FLOOR SINK IN THIS ROOM. PROVIDE ADEQUATE SUPPORTS TO PREVENT ANY MOVEMENT OF DRAIN LINES. DRAIN LINES SHALL ROUTE TO FLOOR SINK WITH A 1" AIR GAP.

ISSUE #	DATE	DESCRIPTION
0	02/29/2016	100% CD
1	05/12/2016	VE Changes

Infrastructure Associates
INFRASTRUCTURE ASSOCIATES, INC.
HOUSTON, TEXAS 77057
TBBE REGISTRATION NO. F-4506
(713) 622-0120 PH. (713) 622-0557 FAX
WWW.IAHOUSTON.COM

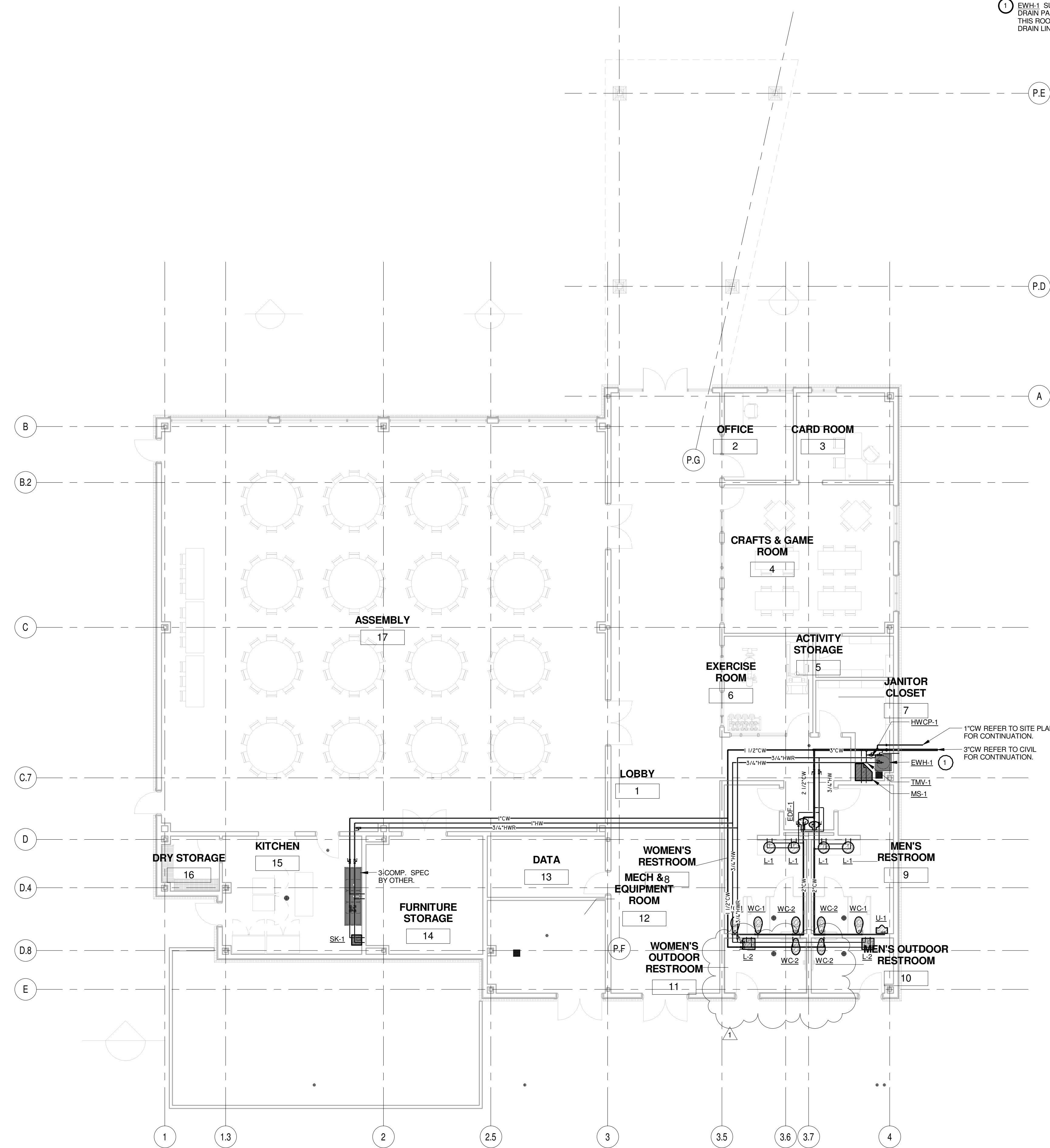

1 DOMESTIC FLOOR PLAN
1/8" = 1'-0"

bdg
architecture
+ planning
boucher design group
Boucher Design Group LLC
Members A.I.A.
6802 Mapleridge, Suite 200
Bellaire, Texas 77401
Tel. 713.785.3644
www.bdgap.com

This document is an instrument of service protected by the copyright law of the United States of America, 17 U.S.C §102, and shall not be copied or reproduced without the express written consent of Boucher Design Group, LLC. 2016



BAYSIDE COMMUNITY CENTER	
BACLIFF, TEXAS	
GALVESTON COUNTY	
DATE	02/29/16
PROJECT NO.	1409000
DRAWN BY	OC/CICT
CHECKED BY	WJK/DG

PLUMBING FLOOR PLAN - DOMESTIC

P301
© COPYRIGHT 2016 BOUCHER DESIGN GROUP, LLC

ISSUE #	DATE	DESCRIPTION
0	02/29/2016	100% CD
1	05/12/2016	VE Changes

Infrastructure Associates
 INFRASTRUCTURE ASSOCIATES, INC.
 617 RICHMOND AVENUE, SUITE 200
 HOUSTON, TEXAS 77002
 TBP# REGISTRATION NO. F-4566
 (713) 622-0120 PH (713) 622-0557 FAX
 WWW.IAHOUSTON.COM

bdg
 architecture
 +planning
 boucher design group

Boucher Design Group LLC
 Members A.I.A.
 6802 Mapleridge, Suite 200
 Bellaire, Texas 77401
 Tel. 713.785.3644
 www.bdgap.com

This document is an instrument of service protected by the copyright law of the United States of America, 17 U.S.C §102, and shall not be copied or reproduced without the express written consent of Boucher Design Group, LLC. 2016

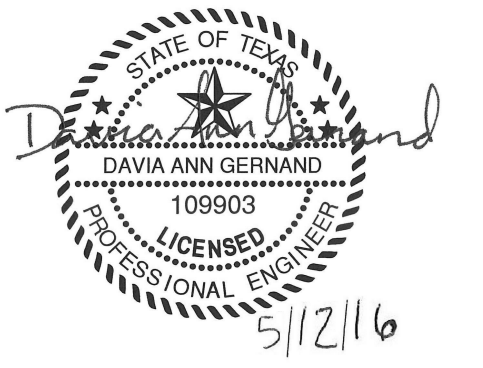

BAYSIDE COMMUNITY CENTER	
BACLIFF, TEXAS	
GALVESTON COUNTY	
DATE	02/29/16
PROJECT NO.	1409000
DRAWN BY	OC/CJ/CT
CHECKED BY	WJK/DG

RISER DIAGRAMS

P401

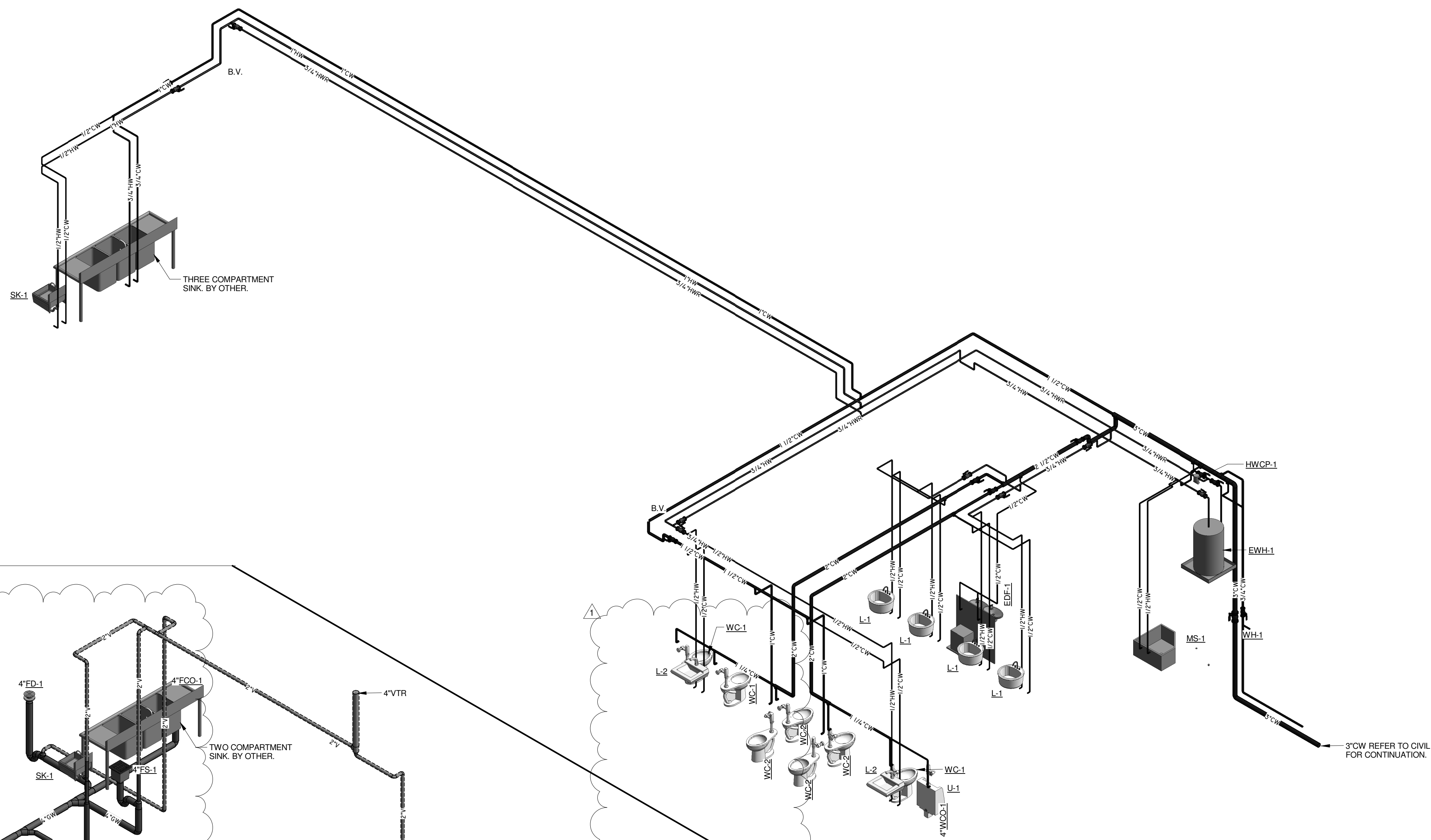

2 3D RISER DIAGRAM - DOMESTIC

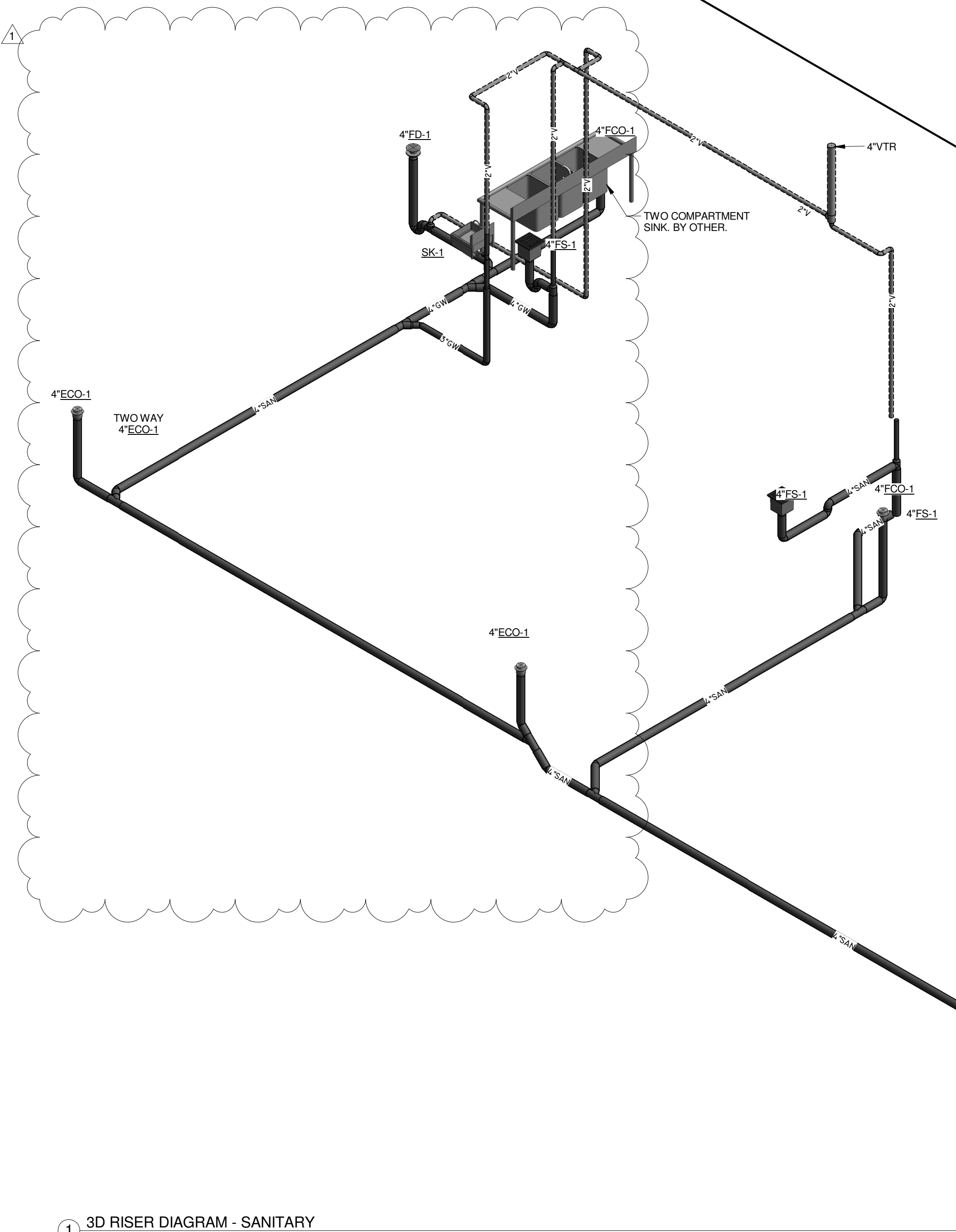

1 3D RISER DIAGRAM - SANITARY

ISSUE #	DATE	DESCRIPTION
1	02/29/2016	100% CD
2	05/12/2016	VE Changes

Infrastructure Associates
 INFRASTRUCTURE ASSOCIATES, INC.
 617 RICHMOND AVENUE, SUITE 200
 HOUSTON, TEXAS 77057
 TEPF REGISTRATION NO. F-4506
 (713) 622-0120 PH (713) 622-0557 FAX
 WWW.IAHOUSTON.COM

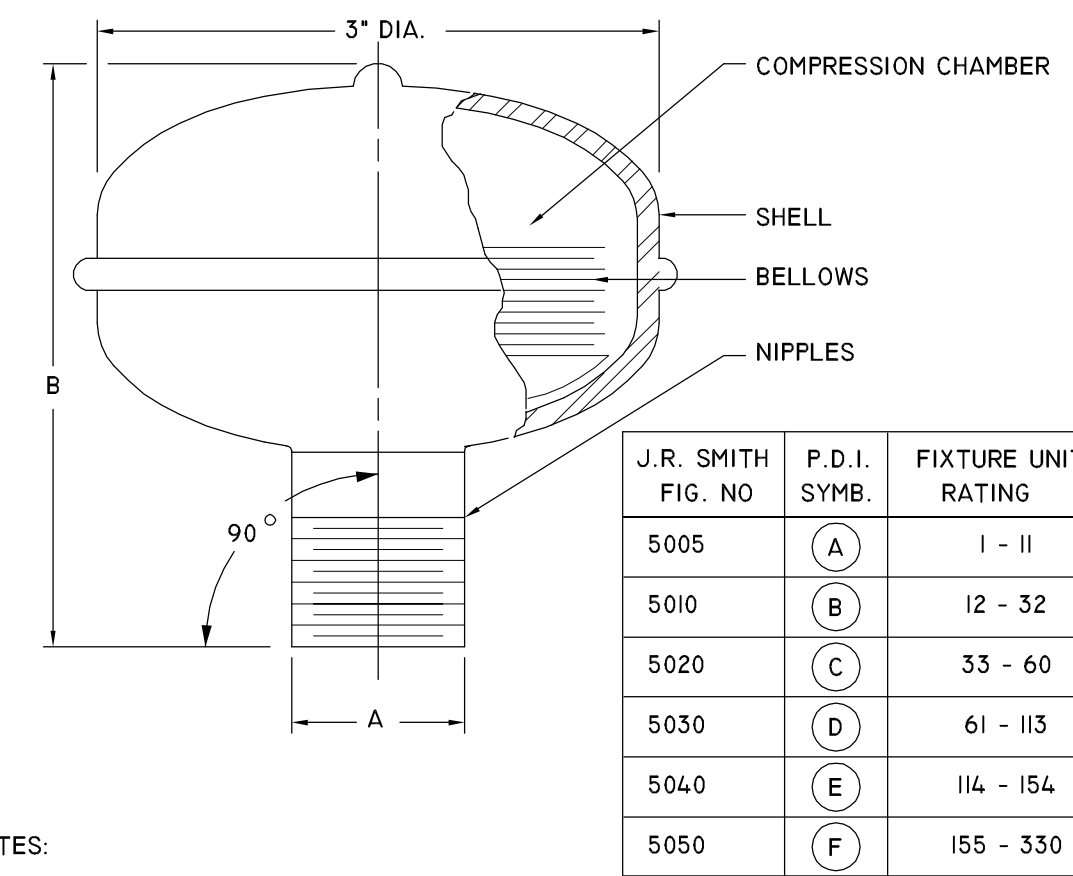

J.R. SMITH FIG. NO	P.D.I. SYMB.	FIXTURE UNIT RATING	A SIZE	B
5005	(A)	I - II	3/4"	4"
5010	(B)	12 - 32	1"	5"
5020	(C)	33 - 60	1"	6"
5030	(D)	61 - 113	1"	7"
5040	(E)	114 - 154	1"	8"
5050	(F)	155 - 330	1"	9"

- NOTES:
 1. ALWAYS INSTALL IN UPRIGHT POSITION
 2. INSTALL AT AN ACCESSIBLE LOCATION. PROVIDE ACCESS PANEL WHERE REQUIRED.
 3. COMPLY WITH THE LATEST UNIFORM PLUMBING CODE

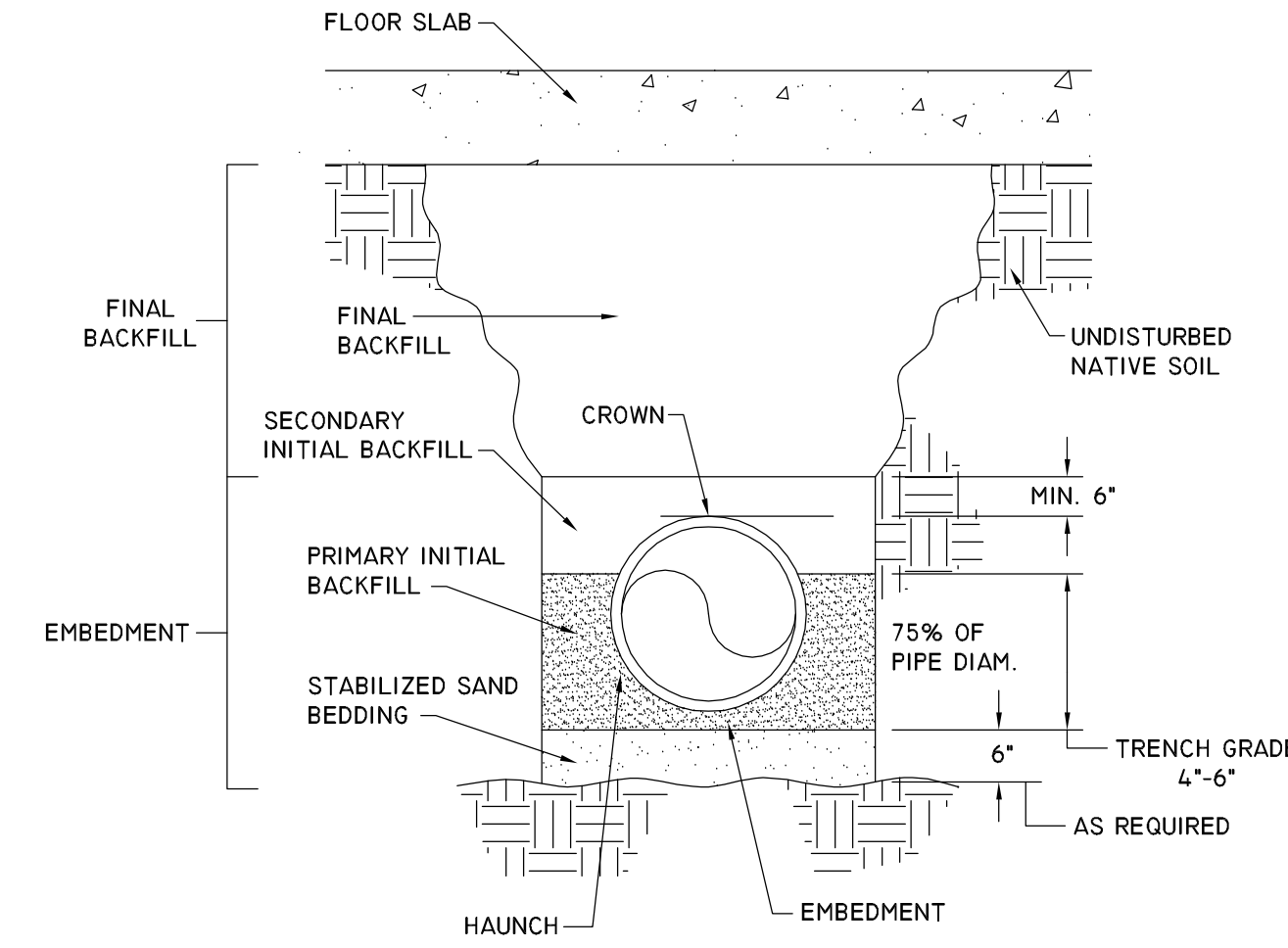

WATER HAMMER ARRESTERS

NOT TO SCALE 5

UNDERGROUND INSTALLATION OF DRAINAGE PIPING

NOT TO SCALE 3

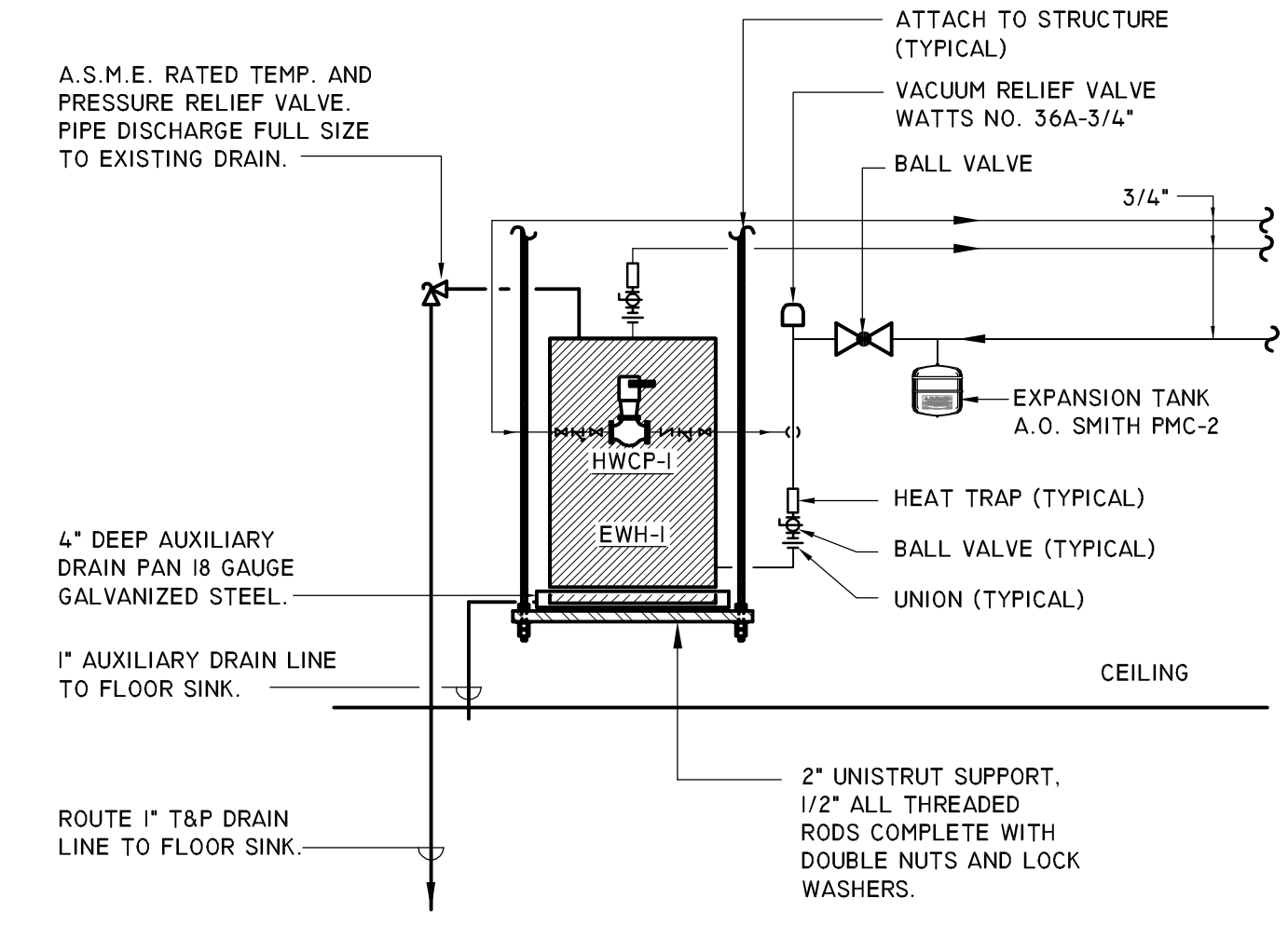
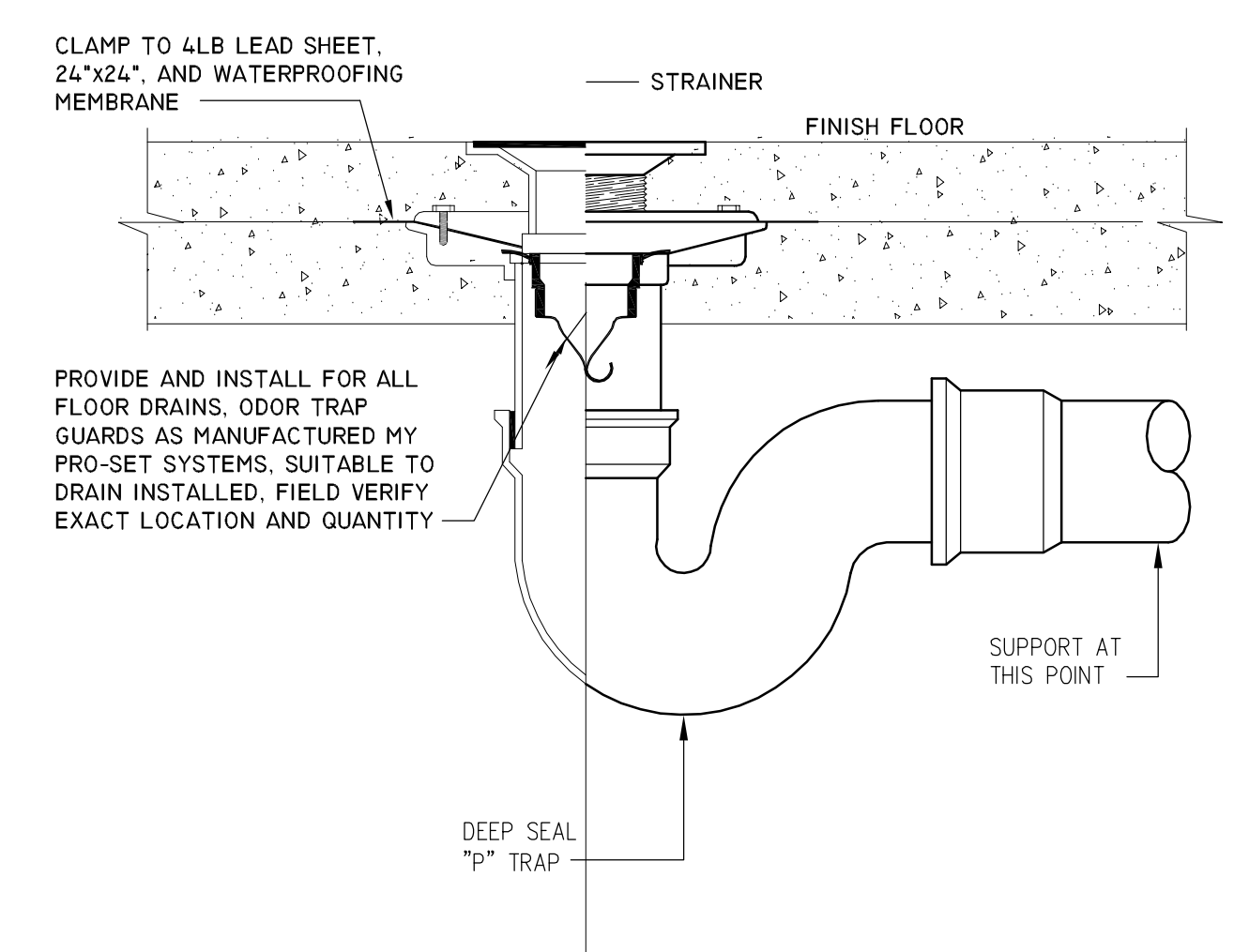

FLOOR DRAIN DETAIL WITH TRAP GUARD - (FD-I)

NOT TO SCALE 9

ELECTRIC WATER HEATER DETAIL

NOT TO SCALE 2

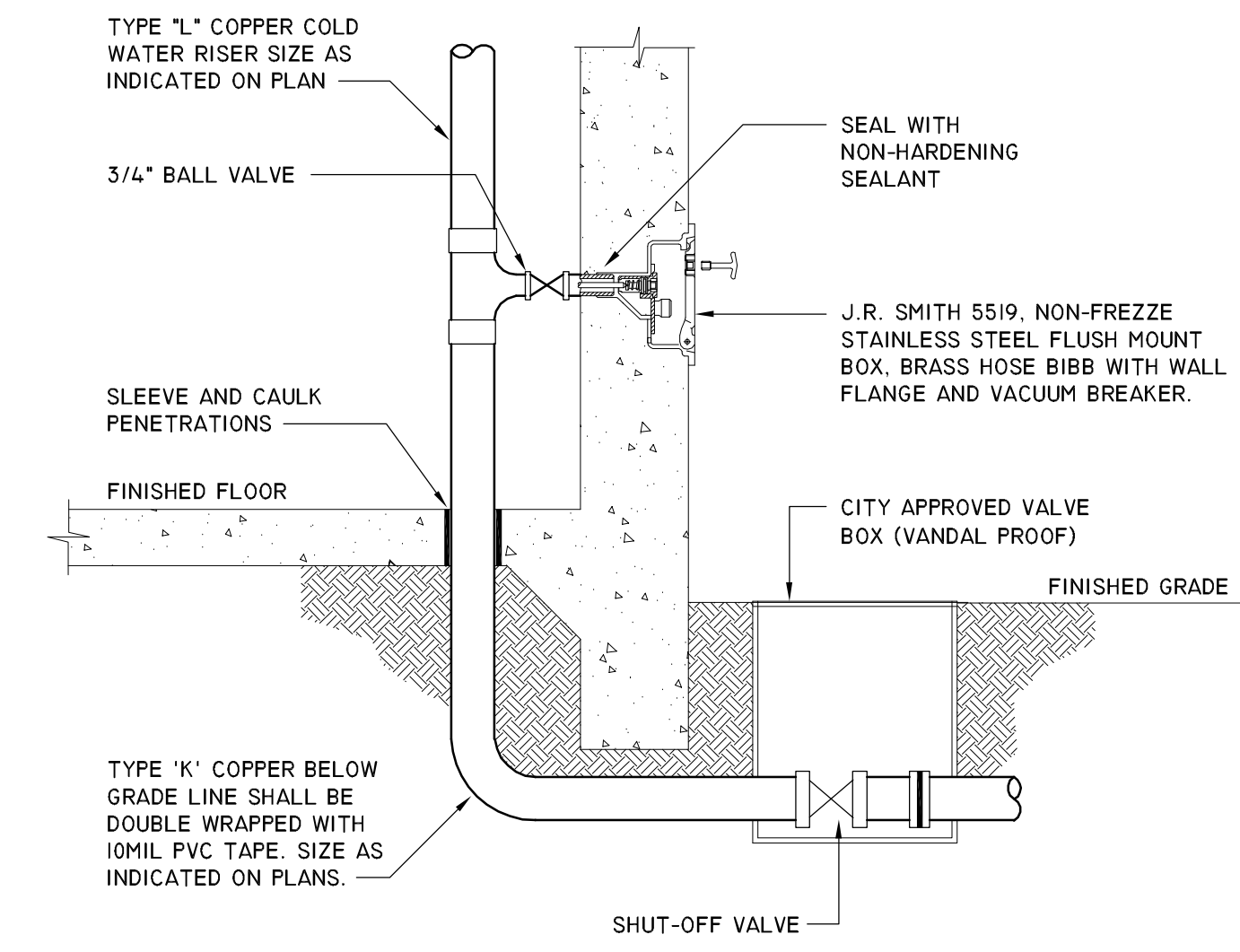
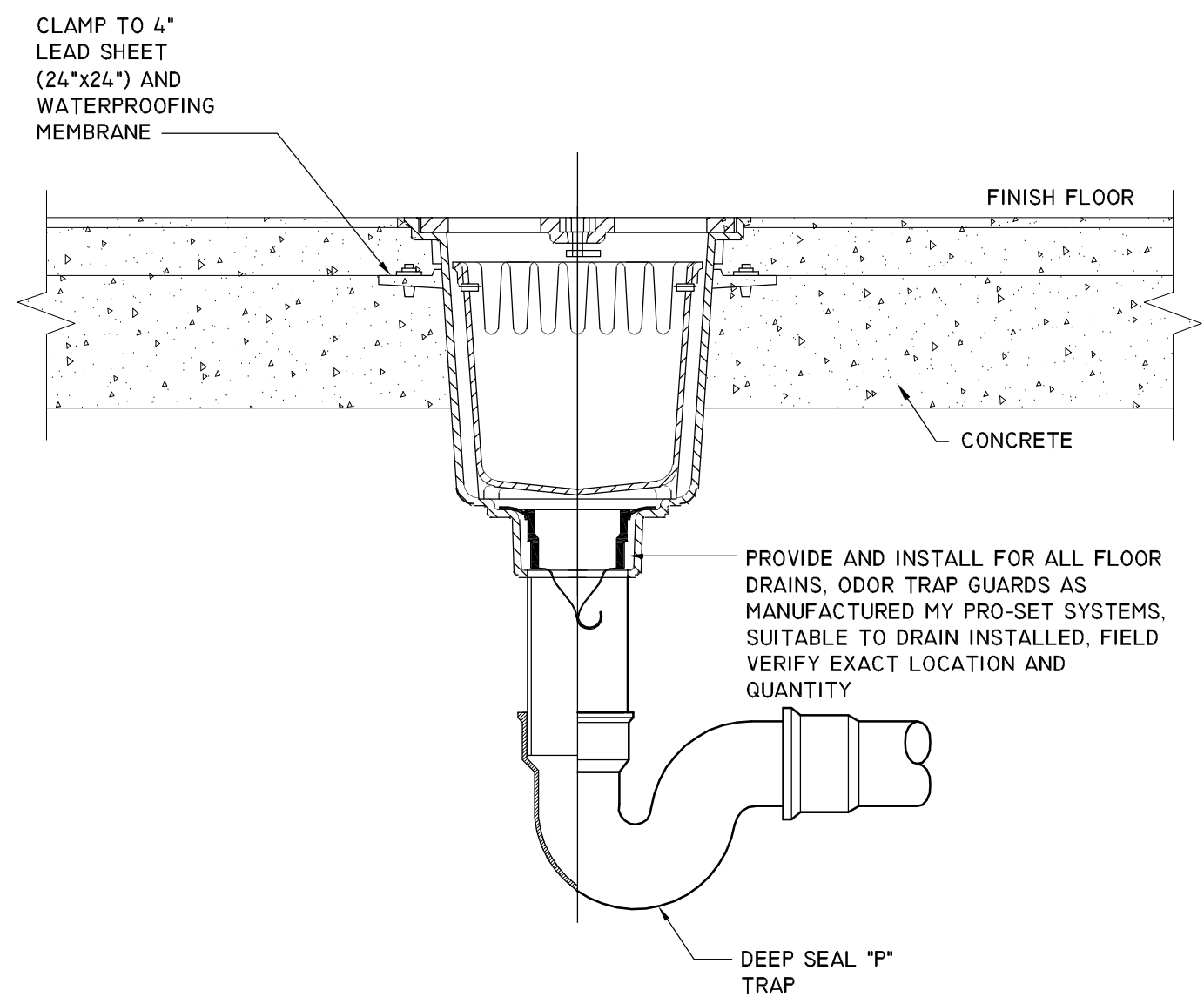
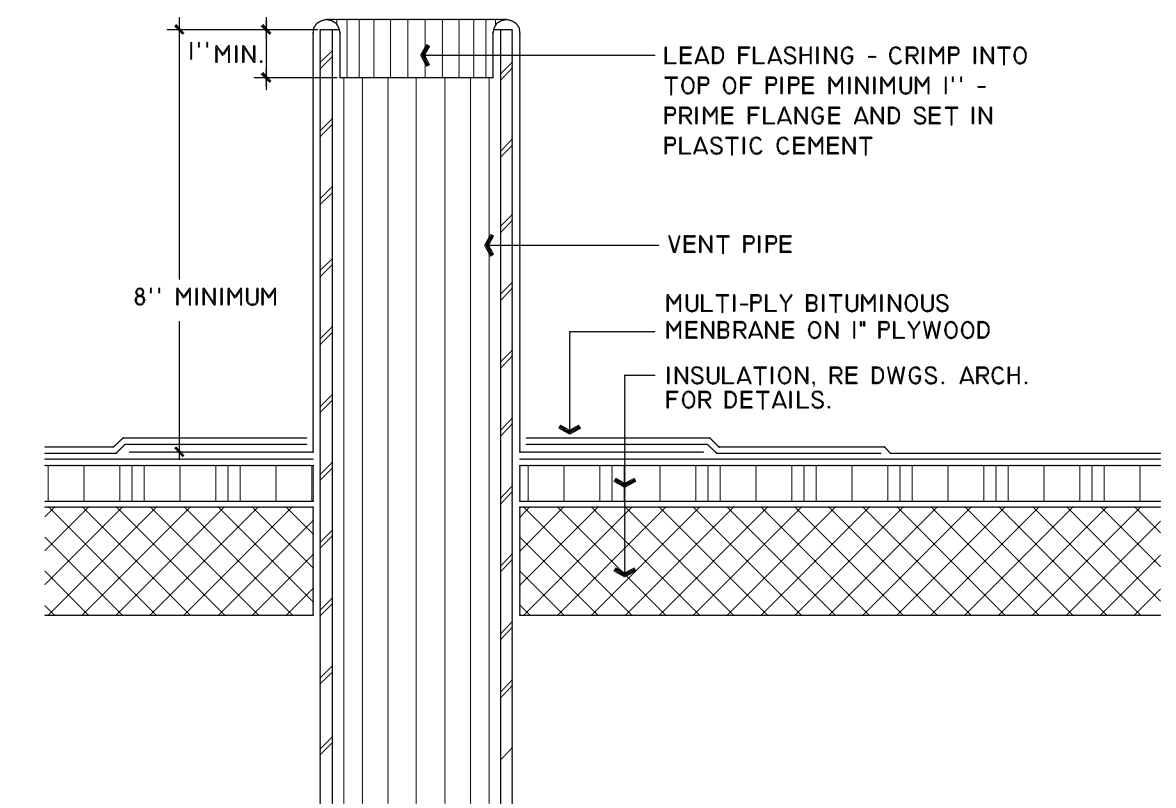

VENT THROUGH ROOF DETAIL (VTR)

NOT TO SCALE 7

FLOOR SINK WITH TRAP GUARD - (FS-I)

NOT TO SCALE 8

DOMESTIC WATER ENTRY DETAIL

NOT TO SCALE 1

bdg
 architecture
 + planning
 boucher design group

Boucher Design Group LLC
 Members A.I.A.
 6802 Maple Ridge, Suite 200
 Bellaire, Texas 77401
 Tel. 713.785.3644
 www.bdgap.com

This document is an instrument of service protected by the copyright law of the United States of America, 17 U.S.C §102, and shall not be copied or reproduced without the express written consent of Boucher Design Group, LLC. 2016



BAYSIDE COMMUNITY CENTER

BACLIFF, TEXAS

GALVESTON COUNTY

DATE	02/29/16
PROJECT NO.	1409000
DRAWN BY	OC/CJCT
CHECKED BY	WJK/DG

DETAILS

P501

© COPYRIGHT 2016 BOUCHER DESIGN GROUP, LLC

ISSUE #	DATE	DESCRIPTION
1	02/29/2016	100% CD



INFRASTRUCTURE ASSOCIATES, INC.
617 RICHMOND AVENUE, SUITE 200
HOUSTON, TEXAS 77002
TELE REGISTRATION NO. F-4506
(713) 622-0120 PH (713) 622-0557 FAX
WWW.IAHOUSTON.COM

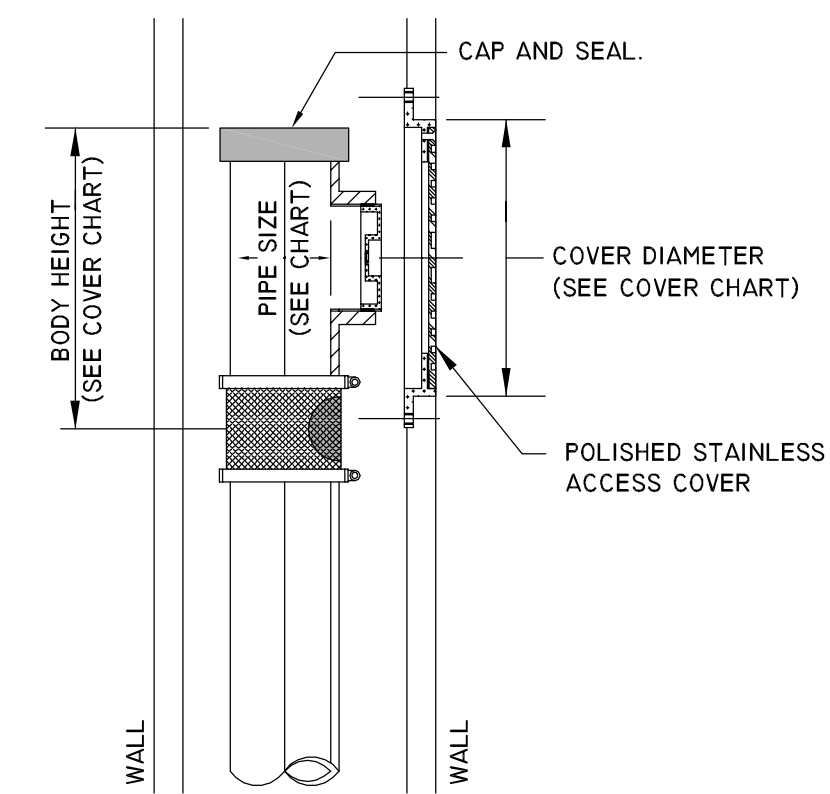

MIFAB WALL CLEAN OUT

MODEL NUMBER	PIPE SIZE (NO HUB)	BODY HEIGHT	STAINLESS STEEL ACCESS COVER	MIN WALL CAVITY SIZE
CI462-R6-3	2"	6.5"	6"	4 1/2"
CI463-R6-3	3"	8.125"	6"	6 1/2"
CI466-R6-3	4"	9.75"	6"	8"
CI466-R9-3	6"	14"	9"	11 1/2"
CI468-R9-3	8"	17"	9"	15"

WALL CLEANOUT DETAIL

NOT TO SCALE 3

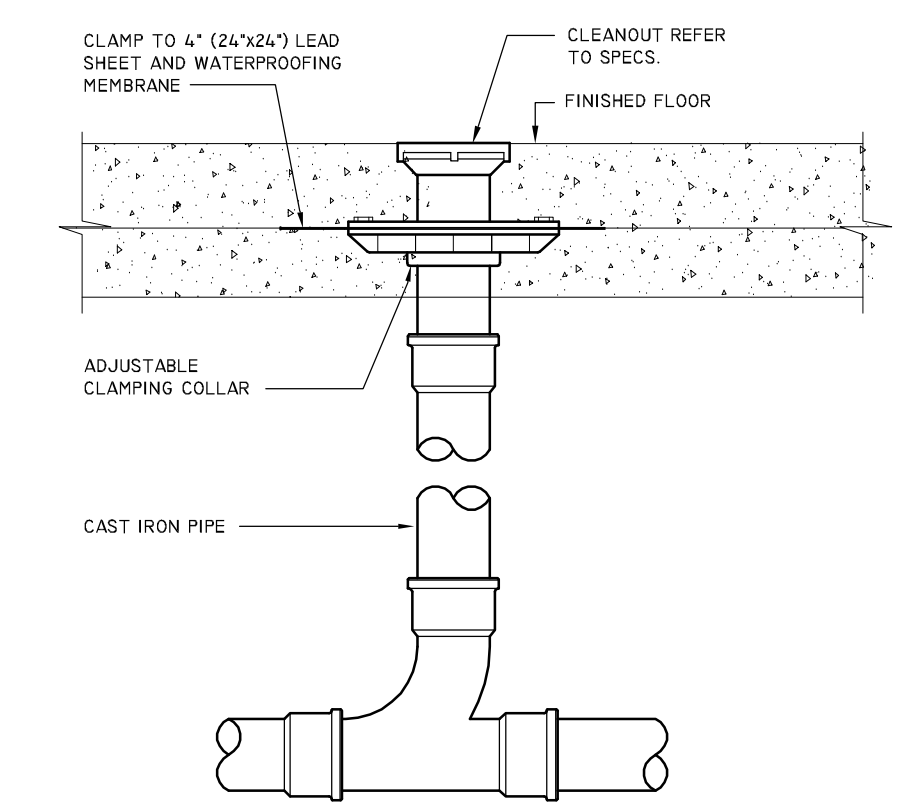

FLOOR CLEANOUT DETAIL - (FC0-1)

NOT TO SCALE 6

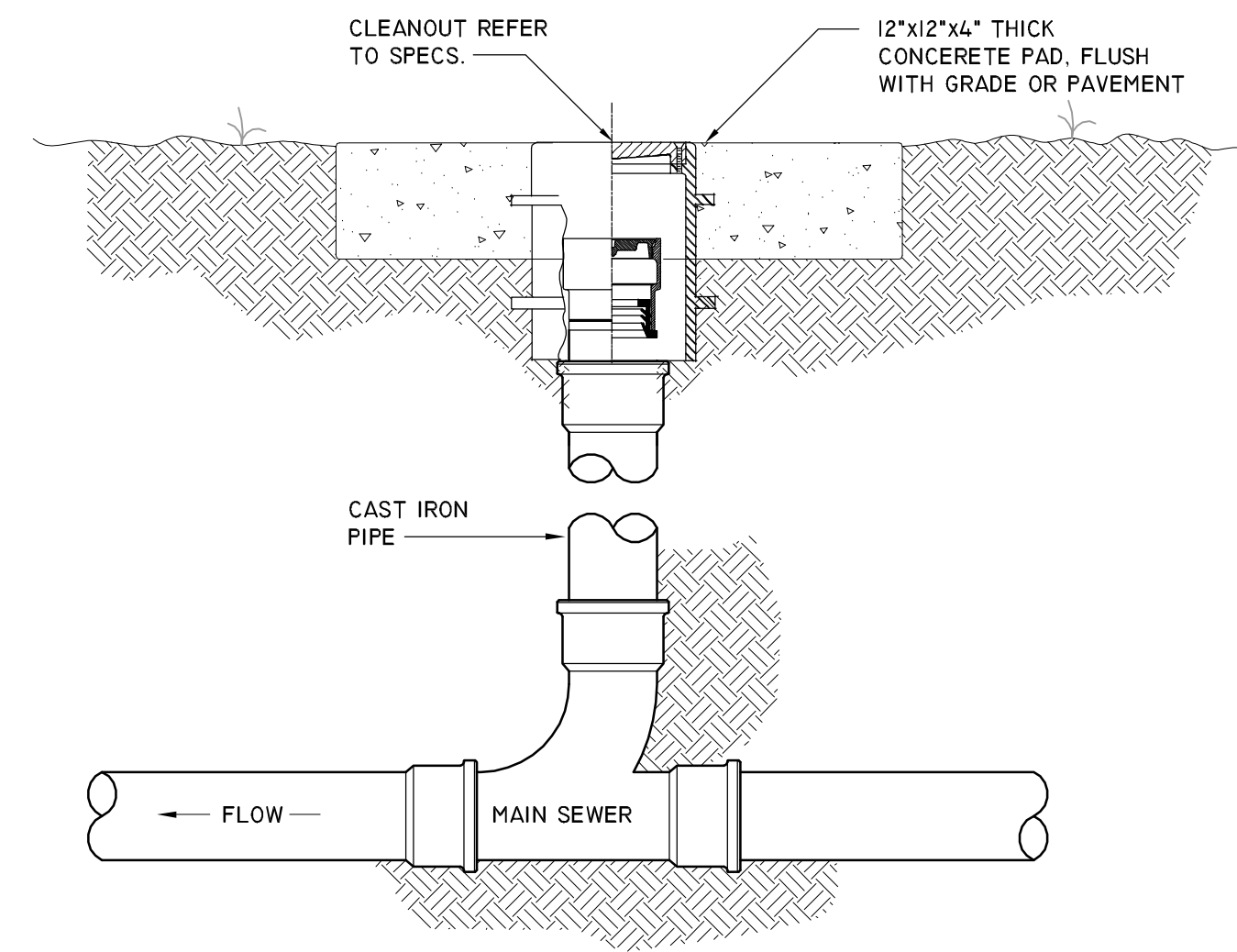

EXTERIOR CLEANOUT DETAIL - (ECO-1)

NOT TO SCALE 4

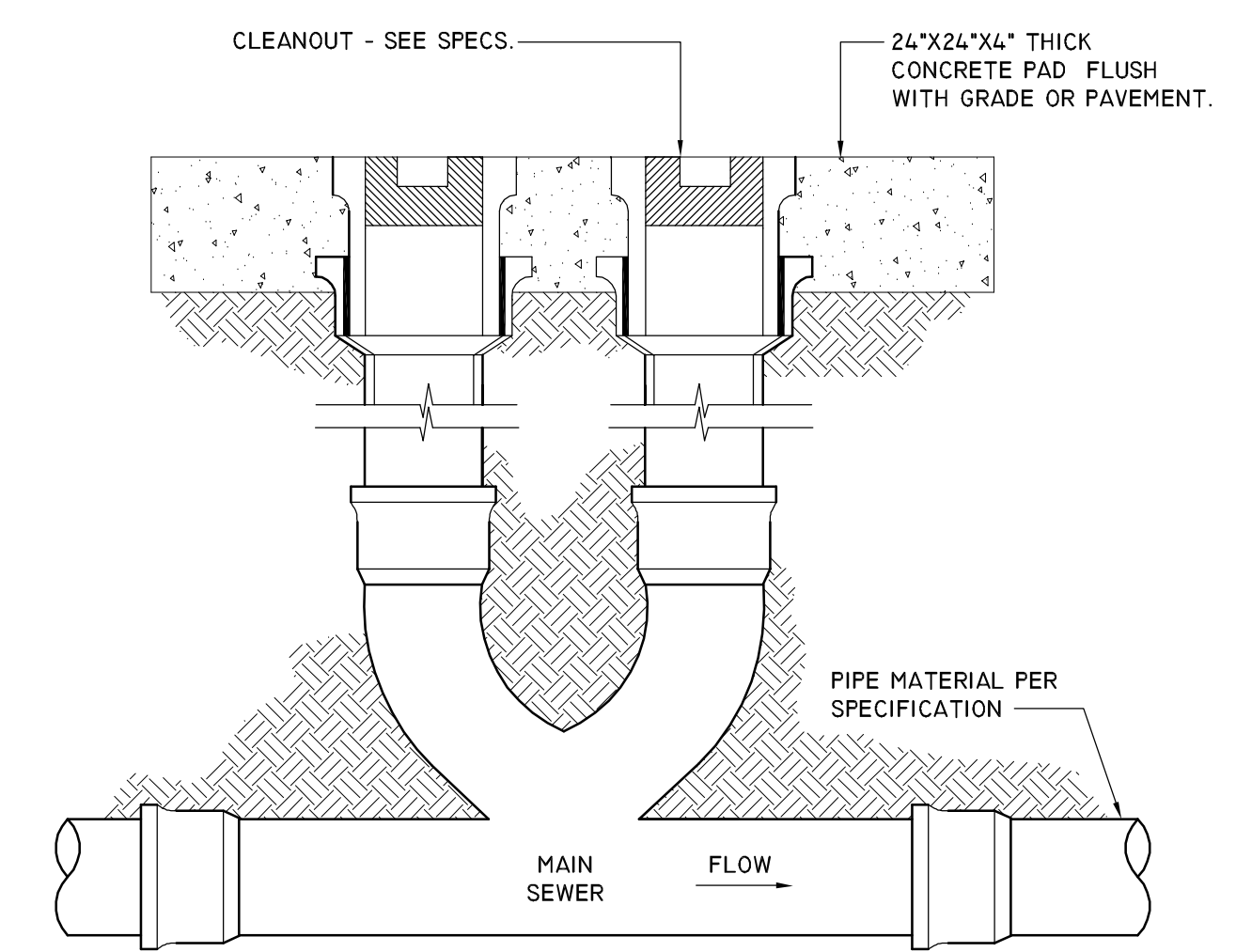

DOUBLE EXTERIOR CLEANOUT

NOT TO SCALE 0



Boucher Design Group LLC
Members A.I.A.
6802 Mapleridge, Suite 200
Bellaire, Texas 77401
Tel. 713.785.3644
www.bdgap.com

This document is an instrument of service protected by the copyright law of the United States of America, 17 U.S.C §102, and shall not be copied or reproduced without the express written consent of Boucher Design Group, LLC. 2016



BAYSIDE COMMUNITY CENTER

BACLIFF, TEXAS

GALVESTON COUNTY

DATE	02/29/16
PROJECT NO.	1409000
DRAWN BY	OC/CJCT
CHECKED BY	WJK/DG

DETAILS

P502

© COPYRIGHT 2016 BOUCHER DESIGN GROUP, LLC

2/26/2016 2:34:17 PM