

**GALVESTON COUNTY
PURCHASING DEPARTMENT**

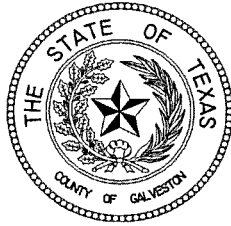

INVITATION TO BID

ITB #B201022

**JERRY J. ESMOND JUVENILE JUSTICE CENTER
ROOF REPLACEMENT**

BID DUE DATE: 02/13/2020

2:00 P.M. CST

***Rufus Crowder, CPPO, CPPB
Purchasing Agent
Galveston County
722 Moody (21st Street)
Fifth (5th) Floor
Galveston, Texas 77550
(409) 770-5372***



**INVITATION TO BID
JERRY J. ESMOND JUVENILE JUSTICE CENTER ROOF REPLACEMENT
GALVESTON COUNTY, TEXAS**

Sealed bids in sets of four (4), one (1) unbound original and three (3) copies will be received in the office of the County Purchasing Agent until 2:00 P.M. CST, on Thursday, February 13, 2020 and opened immediately in that office in the presence of the Galveston County Auditor and the Purchasing Agent. Sealed bids are to be delivered to Rufus G. Crowder, CPPO CPPB, Galveston County Purchasing Agent at the Galveston County Courthouse, 722 Moody (21st Street), Floor 5, Purchasing, Galveston, Texas 77550, (409) 770-5372. The time stamp clock located in the Purchasing Agent's office shall serve as the official time keeping piece for this solicitation process. Any bids received after 2:00 P.M. CST on the specified date will be returned unopened.

Purpose:

Galveston County is seeking a vendor to replace the roof at the Jerry J. Esmond Juvenile Justice Center, located at 6101, Attwater Avenue, Texas City, TX. The existing roof has failed and it has exceeded its useful service life.

All bids must be marked on the outside of the envelope:

ITB #B201022, Jerry J. Esmond Juvenile Justice Center Roof Replacement

Bids name and return address, should be prominently displayed on the bid package for identification purposes.

Bid Specifications can be obtained by visiting the Galveston County website @
<http://www.galvestoncountytexas.gov/pu/Pages/BidListing.aspx>

Bid prices shall be either lump sum or unit prices as shown on the bid sheet, if applicable. The net price will be delivered to Galveston County, including all freight, shipping, and license fees. Galveston County is tax exempt and no taxes should be included in your proposal pricing.

A non-mandatory pre-bid conference will be held on Tuesday, January 21, 2020 at 10:00 a.m. at the Jerry J. Esmond Juvenile Justice Center, 6101 Attwater, Texas City, TX 77590

Upon satisfaction of contractual terms (e.g., goods delivered in promised condition, services rendered as agreed, etc.), contractor shall be paid via Galveston County's normal accounts payable process.

Bonding Requirements:

- **PROPOSAL GUARANTEE:** Evidencing its firm commitment to engage in the contract if Proposer is selected for award of contract, each Proposer is required to furnish with their proposal a Cashier's Check, or an acceptable Bidder's Bond, in the amount of five percent (5%) of the total contract price. The Bidder's Bond must be executed with a surety company authorized to do business in the State of Texas. Failure to furnish the bid/proposal guarantee in the proper form and amount, by the time set for opening of bids may be cause or rejection of the proposal.
- **PERFORMANCE AND PAYMENT BONDS:** Successful proposer, before beginning work, shall execute a performance bond and a payment bond, each of which must be in the amount of the contract. The required payment and performance bonds must each be executed by a corporate surety in accordance with Section 1, Chapter 87, Acts of the 56th Legislature, Regular Session, 1959 (Article 7.19-1, Vernon's Texas Insurance Code).

Attention is called to the fact that not less than, the federally determined prevailing (Davis-Bacon and Related Acts) wage rate, as issued by the Office of Rural Community Affairs and contained in the contract documents, must be paid on this project. In addition, the successful bidder must ensure that employees and applicants for employment are not discriminated against because of race, color, religion, sex age or national origin.

The Galveston County Commissioners' Court reserves the right to waive any informality and to reject any and all bids and to accept the bid or bids which, in its opinion, is most advantageous to Galveston County with total respect the governing laws.

All contractors/subcontractors that are debarred, suspended or otherwise excluded from or ineligible for participation on federal assistance programs may not undertake any activity in part or in full under this project

Rufus G. Crowder, CPPO CPPB
Purchasing Agent
Galveston County

INVITATION TO BID
JERRY J. ESMOND JUVENILE JUSTICE CENTER ROOF REPLACEMENT
GALVESTON COUNTY, TEXAS

Table of Contents

GENERAL PROVISIONS:

| | | |
|-----|--|---|
| 1. | BID PACKAGE | 1 |
| 2. | BIDDER’S RESPONSIBILITY | 1 |
| 3. | TIME FOR RECEIVING BIDS | 1 |
| 4. | COMPETITIVENESS, INTEGRITY, INQUIRIES AND QUESTIONS..... | 2 |
| 5. | BID OPENING..... | 3 |
| 6. | WITHDRAWAL OF BID/FIRM BID RULE | 3 |
| 7. | COMMISSIONERS COURT | 3 |
| 8. | REJECTION OF BIDS/DISQUALIFICATION | 3 |
| 9. | RESTRICTIVE OR AMBIGUOUS SPECIFICATIONS | 4 |
| 10. | SUBSTITUTES/DESCRIPTION OF MATERIALS AND EQUIPMENT | 4 |
| 11. | EXCEPTIONS TO BID | 4 |
| 12. | PRICING | 4 |
| 13. | PROCUREMENT CARD (P-CARD) PROGRAM | 5 |
| 14. | PASS THROUGH COST ADJUSTMENTS | 5 |
| 15. | MODIFICATION OF BIDS | 5 |
| 16. | PRE-BID CONFERENCE | 5 |
| 17. | SIGNATURE OF BIDS | 6 |
| 18. | AWARD OF BIDS – EVALUATION CRITERIA AND FACTORS..... | 6 |
| 19. | DISPUTE AFTER AWARD/PROTEST | 7 |
| 20. | PUBLIC INFORMATION ACT (f/k/a Open Records Act) | 7 |
| 21. | BIDDER’S E-MAIL ADDRESSES – CONSENT TO DISCLOSURE | 8 |
| 22. | RESULTANT CONTRACT | 8 |
| 23. | CONTRACT TERM | 8 |
| 24. | TERMINATION FOR DEFAULT | 8 |
| 25. | TERMINATION FOR CONVENIENCE | 9 |
| 26. | FORCE MAJEURE..... | 9 |

INVITATION TO BID
JERRY J. ESMOND JUVENILE JUSTICE CENTER ROOF REPLACEMENT
GALVESTON COUNTY, TEXAS

27. ESTIMATED QUANTITIES.....10

28. CONTRACTOR INVESTIGATION10

29. NO COMMITMENT BY COUNTY OF GALVESTON10

30. BID COSTS BORNE BY BIDDER.....10

31. BEST AND FINAL OFFIERS (BAFO).....10

32. SINGLE BID RESPONSE10

33. CHANGES IN SPECIFICATIONS10

34. BID IDEAS AND CONCEPTS11

35. BID DISCLOSURES11

36. INDEMNIFICATION11

37. REQUIREMENT OF AND PROOF OF INSURANCE.....12

38. BID GUARANTEE.....13

39. PERFORMANCE AND PAYMENT BONDS (if required).....13

40. PATENT AND COPYRIGHT PROTECTION14

41. CONFLICT OF INTEREST DISCLOSURE REPORTING (FORM CIQ).....14

42. DISCLOSURE OF INTERESTED PARTIES/FORM 1295.....16

43. CERTIFICATION REGARDING DEBARMENT, SUSPENSION, PROPOSED DEBARMENT, AND
OTHER RESPONSIBILITY MATTERS & REQUIREMENT TO REGISTER IN SAM16

44. SOVEREIGN IMMUNITY17

45. CONTROLLING LAW AND VENUE17

46. MERGERS, ACQUISITIONS17

47. DELAYS18

48. ACCURACY OF DATA.....18

49. SUBCONTRACTING/ASSIGNMENT.....18

50. INDEPENDENT CONTRACTOR18

51. MONITORING PERFORMANCE.....18

52. SUBJECT TO APPROPRIATION OF FUNDS19

53. CONTRACTS SUBJECT TO GRANT FUNDING19

54. PROCUREMENT ETHICS19

55. NON-COLLUSION AFFIDAVIT20

56. CERTIFICATION REGARDING LOBBYING.....21

INVITATION TO BID
JERRY J. ESMOND JUVENILE JUSTICE CENTER ROOF REPLACEMENT
GALVESTON COUNTY, TEXAS

57. NON-DISCRIMINATION.....22

58. RECORD RETENTION AND RIGHT TO AUDIT23

59. TITLE VI ASSURANCES/TxDOT23

60. SECTION 231.006, FAMILY CODE/DELINQUENT CHILD SUPPORT.....24

61. ANTITRUST.....24

62. LABOR STANDARDS24

63. PROCUREMENT LAWS.....25

64. ENTIRETY OF AGREEMENT AND MODIFICATION29

65. NOTICE29

66. USE OF DHS SEAL, LOGO, AND FLAGS PROHIBITED WITHOUT PRIOR APPROVAL30

67. FEDERAL GOVERNMENT NOT A PARTY30

68. PROGRAM FRAUD AND FALSE OR FRAUDULENT STATEMENTS OR RELATED ACTS30

69. LEAD AND ASBESTOS.....31

70. ACKNOWLEDGMENT OF GOVERNMENT RECORD31

71. COMPLIANCE WITH GALVESTON COUNTY PURCHASING POLICIES AND PROCEDURES.....31

GENERAL PROVISIONS – INVITATION TO BID
JERRY J. ESMOND JUVENILE JUSTICE CENTER ROOF REPLACEMENT
GALVESTON COUNTY, TEXAS

1. BID PACKAGE

*The Invitation to Bid, general and special provisions, drawings, specifications/line item details, contract documents and the Bid sheet are all part of the Bid package. **BIDs must be submitted in sets of four (4), one (1) unbound original and three (3) copies** on the forms provided by the County if County forms are provided, including the Bid sheets completed in their entirety and signed by an authorized representative by original signature. Failure to complete and sign the Bid sheets/contract page(s) may disqualify the Bid from being considered by the Commissioners' Court. Any individual signing on behalf of the Bidder expressly affirms that he or she is duly authorized to tender this Bid and to sign the Bid sheet/contract under the terms and conditions in this bid on behalf of the Bidder and to bind the Bidder to the terms and conditions of this bid and the Bidder's response hereto. Bidder further understands that its' signing of the contract shall be of no effect unless the contract is subsequently awarded by the Commissioners' Court and the contract properly executed by the Commissioners' Court. All figures must be written in ink or typed. Figures written in pencil or with erasures are not acceptable. However, mistakes may be crossed out, corrections inserted, and initialed in ink by the individual signing the bid. If there are discrepancies between unit prices quoted and extensions, the unit price shall prevail. Each Bidder is required to thoroughly review this entire Bid package to familiarize themselves with the Bid procedures, the plans and specifications for the requested work, as well as the terms and conditions of the contract the successful Bidder will execute with the County.*

2. BIDDER'S RESPONSIBILITY

The Bidder must affirmatively demonstrate its responsibility. The Bidder must also meet the following minimum requirements:

- A. have adequate financial resources or the ability to obtain such resources as required;
- B. be able to comply with all federal, state, and local laws, rules, regulations, ordinances and orders regarding this Invitation to Bid;
- C. have a satisfactory record of performance;
- D. have a satisfactory record of integrity and ethics; and
- E. be otherwise qualified and eligible to receive an award.

3. TIME FOR RECEIVING BIDS

Bids may be submitted by mail or hand delivery and **must be submitted only to the Galveston County Purchasing Agent**. If by delivery, the Bidder must deliver to the reception desk in the County Purchasing Agent's Office. The delivery and mailing instructions for the Galveston County Purchasing Agent are the following:

Rufus Crowder, CPPO CPPB
Galveston County Purchasing Agent
722 Moody, Fifth (5th) Floor
Galveston, Texas 77550

Bids will **not** be accepted by facsimile transmission or by electronic mail (email) unless superseded by instructions within the Special Provisions sections of this solicitation. Bids must be received by the County Purchasing Agent on or before the deadline for the opening of the bids. For clarity, mailing date/postmark is **not** sufficient – bids **must be received** by the County Purchasing Agent on or before the deadline. Late bids will not be accepted and will be returned to the bidder unopened. Bids received prior to the submission deadline will be maintained unopened until the specified time for opening.

**GENERAL PROVISIONS – INVITATION TO BID
JERRY J. ESMOND JUVENILE JUSTICE CENTER ROOF REPLACEMENT
GALVESTON COUNTY, TEXAS**

The County Purchasing Agent will accept bids from 8:00 a.m. to 5:00 p.m. on each business day up to the submission deadline. Business days do not include Saturdays and Sundays, and do not include other days in which the County is closed for business in observance of holidays or for other reasons.

The time-stamp clock within the County Purchasing Agent's Office shall be the official time-clock for the purpose of this solicitation and thus shall be the determinant of whether the bid was timely received.

The bidder should prominently identify the procurement number and name on the outside of the envelope/ mailing package. A label shall be provided for this purpose and usage of the label is preferred. If the bidder fails to identify the bid on the outside of the envelope as required, the Purchasing Agent will open the envelope for the sole purpose of identifying the bid number for which the submission was made. The envelope will then be resealed. No liability will attach to a County office or employee for the premature opening of a bid.

If a bid is not submitted, return this Invitation to Bid and state reason (s), otherwise your name may be removed from the Purchasing Agent's mailing list.

4. COMPETITIVENESS, INTEGRITY, INQUIRIES AND QUESTIONS

To prevent biased evaluations and to preserve the competitiveness and integrity of the procurement process, **bidders are to direct all communications regarding this invitation to bid only to the Galveston County Purchasing Agent**, unless otherwise specifically noted.

Do not contact the requesting department. Attempts by offering firms to circumvent this requirement will be viewed negatively and may result in rejection of the bid of the firm found to be in non-compliance.

All questions regarding this Invitation to Bid must be submitted in writing to:

**Rufus Crowder, CPPO CPPB, Purchasing Agent
722 Moody
Fifth (5th) Floor
Galveston, Texas 77550
Fax: (409) 621-7997
E-mail: purchasing.bids@co.galveston.tx.us**

All questions received and the responses thereto will be mailed, emailed, or faxed to all prospective bidders by addendum. No inquiries except clarification of instructions will be addressed by telephone.

Bidder is advised to carefully review this Invitation to Bid – it provides specific information necessary to aid participating firms in formulating a thorough response. Bidder's failure to examine all documents shall not entitle the bidder to any relief from the conditions imposing in the Invitation to Bid and the resultant contract.

An authorized person from the bidder must sign the bid. This signatory must be a person from the submitting firm who is duly authorized to tender and sign the bid on behalf of the bidder and to bind the bidder to the terms and conditions of this Invitation to Bid, the bidder's response, and all other terms and conditions of the contract. By this signature, the bidder further acknowledges that the bidder has read the bid documents thoroughly before submitting a bid and will fulfill the obligations in accordance to the terms, conditions, and specifications detailed herein.

**GENERAL PROVISIONS – INVITATION TO BID
JERRY J. ESMOND JUVENILE JUSTICE CENTER ROOF REPLACEMENT
GALVESTON COUNTY, TEXAS**

5. BID OPENING

The Purchasing Agent shall open the bids on the date and time specified herein. Information read aloud at the bid opening is at the sole discretion of the Purchasing Agent. The Purchasing Agent will examine bids promptly and thoroughly.

6. WITHDRAWAL OF BID/FIRM BID RULE

Bidders may request withdrawal of their sealed bid prior to the scheduled bid opening time provided the request for withdrawal is submitted to the Purchasing Agent in writing. No bids may be withdrawn for a period of sixty (60) calendar days after opening of the bids.

7. COMMISSIONERS COURT

No contract is binding on the County until it is properly placed on the Commissioners Court agenda, approved in open Court, authorized to be executed by the County Judge, and fully executed by both parties.

Department heads and elected officials are not authorized to enter into any type of agreement or contract on behalf of the County. Only the Commissioners Court acting as a body may enter into a contract on behalf of and contractually bind the County. Additionally, department heads and elected officials are not authorized to agree to any type of supplemental agreements or contracts for goods or services. Supplemental agreements are subject to review by the County Legal Department prior to being accepted and signed by the County's authorized representative.

8. REJECTION OF BIDS/DISQUALIFICATION

Galveston County, acting through its Commissioners Court, reserves the right to:

- reject any and all Bids in whole or in part received by reason of this Invitation to Bid;
- waive any informality in the Bids received;
- disregard the Bid of any Bidder determined to be not responsible;
- disregard the Bid of any Bidder determined to have not submitted its Bid timely; and/or;
- discontinue its efforts for any reason under this Bid package at any time prior to actual execution of contract by the County.

Bidders may be disqualified and rejection of Bids may be recommended to the Commissioners Court for any of (but not limited to) the following causes:

- A. Failure to use the bid forms furnished by the County, if applicable;
- B. Lack of signature by an authorized representative of bidder;
- C. Failure to properly complete the bid;
- D. Engaging in communications regarding this procurement during the pendency of this procurement with County officials and/or personnel who are not within the Purchasing Agent's Office;
- E. Failure to meet the mandatory requirements of this invitation to bid; and/or
- F. Evidence of collusion among bidders.

**GENERAL PROVISIONS – INVITATION TO BID
JERRY J. ESMOND JUVENILE JUSTICE CENTER ROOF REPLACEMENT
GALVESTON COUNTY, TEXAS**

9. RESTRICTIVE OR AMBIGUOUS SPECIFICATIONS

It is the responsibility of the prospective Bidder to review the entire Invitation to Bid packet and to notify the Purchasing Agent if the specifications are formulated in a manner that would restrict competition or appear ambiguous. Any protest or question(s) regarding the specifications or Bid procedures must be received in the Purchasing Agent's Office not less than seventy-two (72) hours prior to the time set for Bid opening. Bidders are to submit their Bid as specified herein or propose an approved equal.

10. SUBSTITUTES/DESCRIPTION OF MATERIALS AND EQUIPMENT

Any brand name or manufacturer reference used herein is intended to be descriptive and not restrictive, unless otherwise noted, and is used to indicate the type and quality of material. The term "or equal" if used, identifies commercially produced items that have the essential performance and salient characteristics of the brand name stated in the item description. All supplies, material, or equipment shall be new and of the most suitable grade for the purpose intended. For clarification, "new" includes products containing recovered materials that are EPA-designated items and additionally see Section 63 of these General Provisions on contracts involving federal funds. It is not the County's intent to discriminate against any materials or equipment of equal merit to those specified. However, if Bidder desires to use any substitutions, prior written approval must be obtained from the Purchasing Agent and sufficiently in advance such that an addendum may be issued. All material supplied must be one hundred percent (100%) asbestos free. Bidder, by submission of its bid, certifies that if awarded any portion of this procurement, the bidder will supply only material and equipment that is 100% asbestos free.

11. EXCEPTIONS TO BID

The Bidder will list on a separate sheet of paper any exceptions to the conditions of the bid. This sheet will be labeled, "Exceptions to Bid Conditions", and will be attached to the bid. If no exceptions are stated, it will be understood that all general and special conditions will be complied with, without exception.

The Bidder must specify in its Bid any alternatives it wishes to propose for consideration by the County. Each alternative should be sufficiently described and labeled within the Bid and should indicate its possible or actual advantage to the program being offered.

The County reserves the right to offer these alternatives to other Bidders.

12. PRICING

Bids will be either lump sum or unit prices as shown on the Bid sheet. The net priced items will be delivered to Galveston County, including all freight, shipping, and delivery charges.

Cash discount must be shown on bid, otherwise prices will be considered net. Unless prices and all information requested are complete, Bid may be disregarded and given no consideration.

In case of default by the contractor, the County of Galveston may procure the articles or services from other sources and may deduct from any monies due, or that may thereafter become due to the contractor, the difference between the price named in the contract of purchase order and the actual cost thereof to the County of Galveston. Prices paid by the County of Galveston shall be considered the prevailing market price at the time such purchase is made. Periods of performance may be extended if the facts as to the cause of delay justify such extension in the opinion of the Purchasing Agent and the Commissioners' Court.

GENERAL PROVISIONS – INVITATION TO BID
JERRY J. ESMOND JUVENILE JUSTICE CENTER ROOF REPLACEMENT
GALVESTON COUNTY, TEXAS

13. PROCUREMENT CARD (P-CARD) PROGRAM

The County of Galveston participates in a Procurement Card (P-Card) program that allows payments made to a vendor by credit card. This method typically results in substantially faster bill payments, sometimes within three (3) to five (5) days of the actual transaction date. All transaction fees from the card provider are to be paid by the successful contractor. If your company will accept payment via credit card (Visa, MasterCard), please notate this in your Bid submittal.

14. PASS THROUGH COST ADJUSTMENTS

Except in instances of extreme extenuating circumstances Contractor prices shall remain firm throughout the contract period and any renewals. Examples of extreme extenuating circumstances include such situations as a nationwide rail strike, oil shortage or oil embargo.

In extreme extenuating circumstances, Contractors may be allowed to temporarily “pass through” additional costs they are forced to incur through no fault of their own. A request for a pass through cost increase will not be considered unless a Contractor’s cost for the Contractor’s product exceeds 10% over the original cost for the product. Also, the increase in cost must be nationwide and consistent for a minimum period of sixty (60) days. Costs that historically are anticipated to rise over a period of time (for example only, such as wages or insurance costs) do not qualify for pass through. If a Contractor thinks he will be asking for a pass through cost adjustment during the term of the contract, then the original cost of the product to Contractor must be stated in Contractor’s original bid.

A request for a pass through cost does not guarantee that one will be granted. Contractors must submit such information on each request as required by the County Purchasing Agent. The County Purchasing Agent will review each request on a case-by-case basis and if valid, submit the request to Commissioners Court for authorization and determination of the appropriateness of each request as well as amount and duration of increase. Contractors will not be permitted any additional compensation for mark-ups or profits based on the increase in price. Rather, such additional compensation will be limited to the actual increase in original cost to the Contractor as such increase is reflected by the original cost stated in the bid. But in no event will the amount of additional compensation exceed 25% increase in Contractor’s original cost for the product as such cost is reflected in Contractor’s original Bid or the duration exceed a period of sixty (60) days. In addition should the cost, during the period of the pass through, return to normal or decrease to below pre pass through prices, appropriate downward adjustments shall be made. No more than one pass through adjustment will be permitted per year.

15. MODIFICATION OF BIDS

A Bidder may modify a bid by letter at any time prior to the submission deadline for receipt of Bids. Modification requests must be received prior to the submission deadline. Modifications made before opening time must be initialed by Bidder guaranteeing authenticity. Bids may not be amended or altered after the official opening with the single exception that any product literature and/or supporting data required by the actual specifications, if any, will be accepted at any time prior to the Commissioners’ Court considering of same.

16. PRE-BID CONFERENCE

A pre-bid conference for the purpose of discussing contract requirements and answering questions of prospective bidders may be conducted in this procurement. A pre-bid conference may be mandatory or voluntary. If the pre-bid conference is mandatory, then the County is authorized to condition acceptance of a bid on compliance with attendance. The Special Provisions of this procurement shall specify if a pre-bid conference is to be held and shall specify whether the pre-bid conference is mandatory or voluntary. Only a principal, officer, or employee of the bidder

GENERAL PROVISIONS – INVITATION TO BID
JERRY J. ESMOND JUVENILE JUSTICE CENTER ROOF REPLACEMENT
GALVESTON COUNTY, TEXAS

may represent the bidder at the pre-bid conference and no person may represent more than one bidder at the pre-bid conference.

17. SIGNATURE OF BIDS

Each Bid shall give the complete mailing address of the Bidder and be signed by an authorized representative by original signature with the authorized representative's name and legal title typed below the signature line. Each bid shall include the Bidder's Federal Employer Identification Number (FEIN). Failure to sign the Contract page(s) and bid response sheets may disqualify the bid from being considered by the County. The person signing on behalf of the Bidder expressly affirms that the person is duly authorized to tender the bid and to sign the bid sheets and contract under the terms and conditions of this Invitation to Bid and to bind the Bidder thereto and further understands that the signing of the contract shall be of no effect until it is properly placed on the Commissioners' Court agenda, approved in open Court, authorized to be executed by the County Judge, and fully executed by both parties.

18. AWARD OF BIDS – EVALUATION CRITERIA AND FACTORS

The award will be made to the responsible Bidder whose bid is determined to be the lowest and best evaluated offer demonstrating the best ability to fulfill the requirements set forth in this Invitation to Bid. **The proposed cost to the County will be considered firm and cannot be altered after the submission deadline.**

“Lowest and best” means a bid or offer providing the best value considering associated direct and indirect costs, including transport, maintenance, reliability, life cycle, warranties, and customer service after a sale.

In determining the lowest and best bid for a contract for the purchase of earth-moving, material-handling, road maintenance, or construction equipment, the Commissioners Court may also consider the information submitted under Section 262.0255 of the Local Government Code; and in determining the lowest and best bid for a contract for the purchase of road construction material, the Commissioners Court may consider the pickup and delivery locations of the bidders and the cost to the county of delivering or hauling the material to be purchased. The Commissioners Court may award contracts for the purchase of road construction material to more than one bidder if each of the selected bidders submits the lowest and best bid for a particular location or type of material.

Each Bidder, by submitting a bid, agrees that if its' bid is accepted by the Commissioners' Court, such Bidder will furnish all items and services upon which prices have been tendered and upon the terms and conditions in this bid and contract.

The contractor shall commence work only after the transmittal of a fully executed contract and after receiving written notification to proceed from the County Purchasing Agent. The contractor will perform all services indicated in the bid in compliance with this contract.

Neither department heads nor elected officials are authorized to sign any binding contracts or agreements prior to being properly placed on the Commissioners' Court agenda and approved in open court. Department heads and other elected officials are not authorized to enter into any type of agreement or contract on behalf of Galveston County. Only the Commissioners' Court, acting as a body, may enter into a contract on behalf of the County. Additionally, department heads and other elected officials are not authorized to agree to any type of supplemental agreements or contracts for goods or services. Supplemental agreements are subject to review by the County Legal Department prior to being signed by the County's authorized representatives.

The County of Galveston reserves the right to accept bids on individual items listed, or group items, or on the bid as a whole; to reject any and all bids; to waive any informality in the bids; to disregard the bids that are not submitted timely; to disregard the bids of bidders determined to be not responsible; and to accept the bid that appears to be in the

GENERAL PROVISIONS – INVITATION TO BID
JERRY J. ESMOND JUVENILE JUSTICE CENTER ROOF REPLACEMENT
GALVESTON COUNTY, TEXAS

best interest of the County. The selection process may, however, include a request for additional information or an oral presentation to support the written bid.

In determining and evaluating the best bid, the pricing may not necessarily be controlling, but quality, equality, efficiency, utility, general terms, delivery, suitability of the service offered, and the reputation of the service in general use will also be considered along with any other relevant items. The Commissioners' Court shall be the sole judge in the determination of these matters.

The County reserves the right to reject any or all Bids in whole or in part received by reason of this Invitation to Bid and may discontinue its efforts under this Invitation to Bid for any reason or no reason or solely for the County's convenience at any time prior to actual execution of the contract by the County.

A Bidder whose bid does not meet the mandatory requirements set forth in this Invitation to Bid may be considered non-compliant.

The invitation to submit a bid which appears in the newspaper, or other authorized advertising mediums, these general provisions, the specifications which follow, the Bid sheets, and any addenda issued are all considered part of the Bid.

Each Bidder, by submitting a bid, agrees that if its bid is accepted by the Commissioners' Court, such Bidder will furnish all items and services upon the terms and conditions in this Invitation to Bid and the resultant contract.

Notice of contract award is anticipated to be made within ninety (90) days of opening of Bids to the lowest responsive and responsible contractor, whose bid complies with all the requirements in the Invitation to Bid.

Contractor shall submit to the County, for approval, within ten (10) days from notice of contract award, all Certificates of Insurance evidencing the required coverage as described under Section 35, Requirement of and Proof of Insurance, or if different, then as described within the Special Provisions or resultant contract.

The contractor shall not commence work under these terms and conditions of the contract until all applicable Purchase Orders, Certificates of Insurance, Performance and Payment Bonds, and Irrevocable Letters of Credit (if required) have been approved by the County of Galveston and the Contractor has received notice to proceed in writing and an executed copy of the contract from the County Purchasing Agent.

19. DISPUTE AFTER AWARD/PROTEST

Any actual or prospective Bidder who is allegedly aggrieved in connection with the solicitation of this Invitation to Bid or award of a contract resulting therefrom may protest. The protest shall be submitted in writing to the Purchasing Agent within seven (7) calendar days after such aggrieved person knows of or should have known of the facts giving rise thereto. If the protest is not resolved by mutual agreement, the Purchasing Agent will promptly issue a decision in writing to the protestant. If the protestant wishes to appeal the decision rendered by the Purchasing Agent, such appeal must be made to the Commissioners' Court through the Purchasing Agent. The decision of the Commissioners' Court will be final. The Commissioners' Court need not consider protests unless this procedure is followed.

20. PUBLIC INFORMATION ACT (f/k/a Open Records Act)

The bidder acknowledges that the County is a government body for purposes of the Public Information Act, codified as Chapter 552 of the Texas Government Code, and as such is required to release information in accordance with the provisions of the Public Information Act.

**GENERAL PROVISIONS – INVITATION TO BID
JERRY J. ESMOND JUVENILE JUSTICE CENTER ROOF REPLACEMENT
GALVESTON COUNTY, TEXAS**

If bidder considers any of its submitted information to be proprietary in nature, trade secret, or otherwise confidential, then it must clearly and conspicuously mark such information as proprietary, trade, secret, or confidential. By the submission of its bid, Bidder expressly affirms that it has clearly and conspicuously marked any information within its submission that Bidder considers confidential, proprietary, and/or trade secret.

In the event the County receives a request for information under the Public Information Act seeking information that the Bidder has marked as confidential, proprietary, and /or trade secret, then the County agrees that it shall provide notice to the Bidder of the request for information and the request for decision process under the Public Information Act. Thus, the County will submit the initial correspondence to the Texas Attorney General – however, the burden is and shall be on the Bidder to submit correspondence to the Attorney General if the Bidder wishes its information to be withheld. Bidder is deemed to have knowledge of the Public Information Act. **By the submission of its bid, bidder expressly acknowledges that the burden to withhold its' information from public disclosure lays with the bidder;** thus, bidder further acknowledges and agrees that it shall submit comments to the Texas Attorney General in the request for decision process if bidder wishes to have its' information withheld from public disclosure.

21. BIDDER'S E-MAIL ADDRESSES – CONSENT TO DISCLOSURE

Notwithstanding the foregoing Section 19, Bidder acknowledges and agrees that the confidentiality of any and all email addresses Bidder uses or discloses in communicating with the County are **open** to the public in accordance with Section 552.137 of the Government Code and Bidder consents to the release of its email addresses.

22. RESULTANT CONTRACT

Bidder shall correctly and fully execute the resultant contract first. After this, the contract shall be set for consideration by the Commissioners' Court. If the Commissioners' Court authorizes the execution of the contract, the resultant contract shall become effective upon the Commissioners' Court execution of same, provided that the contract is executed by all parties to the contract. Contract documents shall consist of the contract, the General and Special Provisions, drawings, bid package (including best and final offer(s) if such is utilized), any addenda issued, and any change orders issued during the work. If applicable to the attached bid, bidder must sign three (3) original contracts and return all three with their bid submittal.

Bidder should submit a proposed contract with its Bid or its sample material terms and conditions for review and consideration.

23. CONTRACT TERM

The term of the resultant contract will begin on the date of full execution or the execution by the Commissioners' Court, whichever is later, and will terminate on the date specified in the resultant contract unless terminated earlier as herein set forth.

24. TERMINATION FOR DEFAULT

Failure of either party in the performance of any of the provisions of this contract shall constitute a breach of contract, in which case either party may require corrective action within ten (10) business days from date of receipt of written notice citing the exact nature of such breach. Failure of the party being notified to take corrective action within the

GENERAL PROVISIONS – INVITATION TO BID
JERRY J. ESMOND JUVENILE JUSTICE CENTER ROOF REPLACEMENT
GALVESTON COUNTY, TEXAS

prescribed ten (10) business days, or failure to provide written reply of why no breach has occurred, shall constitute a Default of Contract.

All notices relating to default by Bidder of the provisions of the contract shall be issued by the County through its Legal Department, and all replies shall be made in writing to the County Legal Department. Notices issued by or issued to anyone other than the County Legal Department shall be null and void and shall be considered as not having been issued or received.

Galveston County reserves the right to enforce the performance of this contract in any manner prescribed by law in the event of breach or default of this contract, and may contract with another party, with or without solicitation of bids or further negotiations. At a minimum, Bidder shall be required to pay any difference in service or materials, should it become necessary to contract with another source, plus reasonable administrative costs and attorney fees.

In the event of Termination for Default, Galveston County, its agents or representatives shall not be liable for loss of any profits anticipated to be made by Bidder.

In addition to the remedies stated herein, the County has the right to pursue other remedies permitted by law or in equity.

No waiver by either party of any event of default under this agreement shall operate as a waiver of any subsequent default under the terms of this agreement.

County reserves the right to terminate this contract immediately in the event Bidder:

- A. Fails to meet delivery or completion schedules; and/or
- B. Fails to otherwise perform in accordance with the accepted Bid and the contract.

25. TERMINATION FOR CONVENIENCE

County may terminate this contract upon at least thirty (30) calendar days prior written notice for its convenience or for any reason deemed by the County to serve the public interest. As well, County may terminate this contract upon thirty (30) calendar days prior written notice for any reason resulting from any governmental law, order, ordinance, regulation, or court order. In no event shall County be liable for loss of any profits anticipated to be made hereunder by Bidder should this contract be terminated early.

26. FORCE MAJEURE

If by reason of Force Majeure either Party shall be rendered unable, wholly or in part, to carry out its responsibilities under this contract by any occurrence by reason of Force Majeure, then the Party unable to carry out its responsibility shall give the other Party notice and full particulars of such Force Majeure in writing within a reasonable time after the occurrence of the event, and such notice shall suspend the Party's responsibility for the continuance of the Force Majeure claimed, but for no longer period.

Force Majeure means acts of God, floods, hurricanes, tropical storms, tornadoes, earthquakes, or other natural disasters, acts of a public enemy, acts of terrorism, sovereign conduct, riots, civil commotion, strikes or lockouts, and other causes that are not occasioned by either Party's conduct which by the exercise of due diligence the Party is unable to overcome and which substantially interferes with operations.

**GENERAL PROVISIONS – INVITATION TO BID
JERRY J. ESMOND JUVENILE JUSTICE CENTER ROOF REPLACEMENT
GALVESTON COUNTY, TEXAS**

27. ESTIMATED QUANTITIES

Any reference to quantities shown in the Invitation to Bid is an estimate only. Since the exact quantities cannot be predetermined, the County reserves the right to adjust quantities as deemed necessary to meet its requirements.

28. CONTRACTOR INVESTIGATION

Before submitting a bid, each Bidder shall make all investigations and examinations necessary to ascertain all site conditions and requirements affecting the full performance of the contract and to verify any representations made by the County upon which the contractor will rely. Bidder shall exercise due diligence and is further charged with knowledge of the local, State, and Federal laws, rules, and regulations applicable to this contract. If the bidder receives an award as a result of its bid submission in this procurement, the bidder's failure to have made such investigations and examinations will in no way relieve the bidder from its obligation to comply in every detail with all provisions and requirements of the contract, nor will a plea of ignorance of such conditions and requirements be accepted as a basis for any claim whatsoever by the contractor for additional compensation and/or for excused nonperformance.

29. NO COMMITMENT BY COUNTY OF GALVESTON

This Invitation to Bid does not commit the County of Galveston to award any costs or pay any costs, or to award any contract, or to pay any costs associated with or incurred in the preparation of a bid in response to this Invitation to Bid and does not commit the County of Galveston to procure or contract for services or supplies.

30. BID COSTS BORNE BY BIDDER

Galveston County shall not be liable for any costs incurred by Bidder in preparation, production, or submission of a bid, including but not limited to best and final offer if applicable. As well, Galveston County shall not be liable for any work performed by Bidder prior to issuance of fully executed contract and properly issued notice to proceed. Galveston County shall not be liable for any costs incurred by Bidder by reason of attending a pre-Bid conference. Galveston County shall not be liable for any costs incurred by Bidder by reason of the County invoking use of best and final offers.

31. BEST AND FINAL OFFIERS (BAFO)

Not applicable.

32. SINGLE BID RESPONSE

If only one bid is received in response to the Invitation to Bid, a detailed cost bid may be requested of the single bidder. A cost/price analysis and evaluation and/or audit may be performed of the cost bid in order to determine if the price is fair and reasonable.

33. CHANGES IN SPECIFICATIONS

If it becomes necessary to revise any part of this bid, a written notice of such revision will be provided to all Bidders in the form of addenda. The County is not bound by any oral representations, clarifications, or changes made in the written specifications by the County's employees or officials, unless such clarification or change is provided to

**GENERAL PROVISIONS – INVITATION TO BID
JERRY J. ESMOND JUVENILE JUSTICE CENTER ROOF REPLACEMENT
GALVESTON COUNTY, TEXAS**

Bidders in a written addendum from the Purchasing Agent. Bidders are advised to inquire prior to the submission deadline as to whether any addenda to this invitation to bid have been issued, as the successful bidder will be required to abide by such addenda.

The County of Galveston reserves the right to revise or amend the specifications up to the time set for opening of bids. Such revisions and amendments, if any, shall be announced by form of addenda. Copies of such addenda (or addendum in the event only one addendum is issued in the procurement) shall be furnished to all prospective contractors. Prospective contractors are defined as those contractors listed on the County's Invitation to Bid list for this material/service or those who have obtained documents from the Purchasing Agent's Office subsequent to the advertisement. If revisions and amendments require changes in quantities or prices proposed, or both, the date set for opening of bids may be postponed by such number of days as in the opinion of the County shall enable contractors to revise their bids. In any case, the bid opening shall be at least seven (7) business days after the last revising or amendment addendum and the addendum shall include an announcement of the new date, if applicable, for the opening of bids.

34. BID IDEAS AND CONCEPTS

The County reserves to itself the right to adopt or use for its benefit, any concept, plan, or idea contained in any bid.

35. BID DISCLOSURES

While this procurement is pending, the names of those who submitted bids will not be made public unless in conformity with the County Purchasing Act. Likewise, no pricing or staffing information will be released unless in conformity with the County Purchasing Act. Bidders are requested to withhold all inquiries regarding their bid or other submissions until after an award is made. No communication is to be had with any County employee or official, other than the County Purchasing Agent, regarding whether a bid was received - violations of this provision may result in the rejection of a bid.

36. INDEMNIFICATION

The contractor agrees to assume all risks and responsibility for, and agrees to indemnify, defend, and save harmless, the County of Galveston, its elected and appointed officials and department heads, agents and employees from and against all claims, demands, suits, actions, recoveries, judgments, and costs and expenses including reasonable attorney's fees for the defense thereof arising out of or in connection therewith on account of the loss of life, property or injury or damage to the person which shall arise from contractor's operations under this contract, its use of County facilities and/or equipment or from any other breach on the part of the contractor, its employees, agents or any person(s), in or about the County's facilities with the expressed or implied consent of the County. Contractor shall pay any judgment with cost which may be obtained against Galveston County resulting from contractor's operations under this contract.

Contractor agrees to indemnify and hold the County harmless from all claims of subcontractors, laborers incurred in the performance of this contract. Contractor shall furnish satisfactory evidence that all obligations of this nature herein above designated have been paid, discharged or waived. If Contractor fails to do so, then the County reserves the right to pay unpaid bills of which County has written notice direct and withhold from Contractor's unpaid compensation a sum of money reasonably sufficient to liquidate any and all such lawful claims.

**GENERAL PROVISIONS – INVITATION TO BID
JERRY J. ESMOND JUVENILE JUSTICE CENTER ROOF REPLACEMENT
GALVESTON COUNTY, TEXAS**

37. REQUIREMENT OF AND PROOF OF INSURANCE

The successful Bidder shall furnish evidence of insurance to the County Purchasing Agent and shall maintain such insurance as required hereunder or as may be required in the Special Provisions or resultant contract, if different. Contractor shall obtain and thereafter continuously maintain in full force and effect, commercial general liability insurance, including but not limited to bodily injury, property damage, and contractual liability, with combined single limits as listed below or as may be required by State or Federal law, whichever is greater.

- A. For damages arising out of bodily injury to or death of one person in any one accident :
ONE HUNDRED THOUSAND AND NO/100 (\$100,000.00) DOLLARS.
- B. For damages arising out of bodily injury to or death of two or more persons in any one accident:
THREE HUNDRED THOUSAND AND NO/100 (\$300,000.00) DOLLARS.
- C. For any injury to or destruction of property in any one accident :
ONE HUNDRED THOUSAND AND NO/100 (\$100,000.00) DOLLARS.

Insurance shall be placed with insurers having an A.M. Best's rating of no less than A. Such insurance must be issued by a casualty company authorized to do business in the State of Texas, and in standard form approved by the Board of Insurance Commissioners of the State of Texas, with coverage provisions insuring the public from loss or damage that may arise to any person or property by reason of services rendered by Contractor.

Galveston County shall be listed as the additional insured on policy certificates and shall be provided with no less than thirty (30) calendar days prior notice of any changes to the policy during the contractual period.

Certificates of Insurance, fully executed by a licensed representative of the insurance company written or countersigned by an authorized Texas state agency, shall be filed with the County Purchasing Agent within ten (10) business days of issuance of notification from the County Purchasing Agent to Bidder that the contract is being activated as written proof of such insurance and further provided that Bidder shall not commence work under this contract until it has obtained all insurance required herein, provided written proof as required herein, and received written notice to proceed issued from the County Purchasing Agent.

Proof of renewal/replacement coverage shall be provided prior to the expiration, termination, or cancellation date of any policy and Galveston County shall be named as an additional insured on any such renewal/replacement coverage and a certificate of insurance showing such shall be provided to the Purchasing Agent. Said insurance shall not be cancelled, permitted to expire, or changed without at least thirty (30) days prior written notice to the County.

Insurance required herein shall be maintained in full force and effect during the life of this contract and shall be issued on an occurrence basis. Contractor shall require that any and all subcontractors that are not protected under the Contractor's own insurance policies take and maintain insurance of the same nature and in the same amounts as required of Contractor and provide written proof of such insurance to Contractor. Proof of renewed/replacement coverage shall be provided prior to the expiration, termination, or cancellation date of any policy. Contractor shall not allow any subcontractor to commence work on the subcontract until such insurance required for the subcontractor has been obtained and approved.

Workers' Compensation Insurance: Successful Bidder shall carry in full force Workers' Compensation Insurance Policy(ies), if there is more than one employee, for all its' employees, including but not limited to full time, part time, and emergency employees employed by the successful Bidder. Current insurance certificates certifying that such policies as specified above are in full force and effect shall be furnished by successful Bidder to the County.

Insurance is to be placed with insurers having a Best rating of no less than A. The Bidder shall furnish the County with certificates of insurance and original endorsements affecting coverage required by these insurance clauses within

**GENERAL PROVISIONS – INVITATION TO BID
JERRY J. ESMOND JUVENILE JUSTICE CENTER ROOF REPLACEMENT
GALVESTON COUNTY, TEXAS**

ten (10) business days of receiving notification from the County Purchasing Agent that the contract is being activated. The certificates and endorsements for each insurance policy are to be signed by a person authorized by the insurer to bind coverage on its behalf. The Bidder shall be required to submit annual renewals for the term of this contract prior to expiration of any policy.

In addition to the remedies stated herein, the County has the right to pursue other remedies permitted by law or in equity.

The County agrees to provide Bidder with reasonable and timely notice of any claim, demand, or cause of action made or brought against the County arising out of or related to utilization of the property. Bidder shall have the right to defend any such claim, demand, or cause of action at its sole cost and expense and within its sole and exclusive discretion. The County agrees not to compromise or settle any claim or cause of action arising out of or related to the utilization of the property without the prior written consent of the Bidder.

In no event shall the County be liable for any damage to or destruction of any property belonging to the Bidder.

Subrogation Waiver. Bidder and Bidder's insurance carrier waive any and all rights to subrogation against Galveston County in regard to any suit or claim arising out of personal injury or property damage resulting from Bidder's performance under this agreement.

38. BID GUARANTEE

Unless specified differently within the Special Provisions of this procurement, each Bidder shall be required to submit a bid guarantee with its bid as required within this Section.

Evidencing its firm commitment to engage in contract if Bidder is selected for award of contract, each Bidder is required to furnish with their bid a cashier's check or an acceptable Bidder's bond in the amount of five percent (5%) of the total contract price. If Bidder is using a bond, then the Bidder bond must be executed with a surety company authorized to do business in the State of Texas. Failure to furnish the bid guarantee in the proper form and amount, by the time set for opening of bids may be cause for rejection of the bid.

The cashier's check or Bidder/bid bond (as applicable) will be returned to each respective unsuccessful Bidder(s) subsequent to the Commissioners Court award of contract, and shall be returned to the successful Bidder upon the completion and submission of all contract documents. Provided however, that the cashier's check or Bidder bond will be forfeited to the County as liquidated damages should successful Bidder fail to execute the contract within thirty (30) days after receiving notice of the acceptance of its bid.

39. PERFORMANCE AND PAYMENT BONDS (if required)

Successful Bidder, before beginning work, shall execute a performance bond and a payment bond, each of which must be in the amount of the contract. The required payment and performance bonds must each be executed by a corporate surety authorized to write surety bonds in the State of Texas and in accordance with Chapter 3503 of the Insurance Code (codified in 2005 and originally within Section 1, Chapter 87, Acts of the 56th Leg., R.S., 1959, and in Article 7.19-1, Vernon's Texas Insurance Code).

The performance and payment bonds must each clearly and prominently display on the bond or on an attachment to the bond:

- a.) The name, mailing address, physical address, and telephone number, including the area code, of the surety company to which any notice of claim should be sent; or
- b.) The toll-free telephone number maintained by the Texas Department of Insurance under Subchapter B, Chapter

**GENERAL PROVISIONS – INVITATION TO BID
JERRY J. ESMOND JUVENILE JUSTICE CENTER ROOF REPLACEMENT
GALVESTON COUNTY, TEXAS**

521, Insurance Code, and a statement that the address of the surety company to which any notice of claim should be sent may be obtained from the Texas Department of Insurance by calling the toll free-telephone number.

The performance bond shall be solely for the protection of Galveston County, in the full amount of the contract, and conditioned on the faithful performance of the work in accordance with the plans, specifications, and contract documents. The payment bond is solely for the protection and use of payment bond beneficiaries who have a direct contractual relationship with the prime contractor or a subcontractor to supply labor or material, and in the amount of the contract.

The payment and performance bonds required to be furnished herein must be furnished before the contractor begins work and are a requirement for issuance of a Notice to Proceed. Such bonds must be furnished to the Galveston County Purchasing Agent within thirty (30) calendar days after the date of the full execution of the contract or, if applicable, as required under Chapter 2253, Government Code, whichever is earlier. Contractor's failure to provide the required payment and performance bonds within such time period shall constitute an event of default under this contract. Contractor shall not commence work until all applicable certificates of insurance, performance bonds, and payment bonds have been received and approved by the County Purchasing Agent and the Contractor receives notice to proceed in writing that has been issued by the County Purchasing Agent.

Additionally, if this request for bid is for the award of a public works contract, then compliance with Chapter 2253 of the Texas Government Code, which is known as the McGregor Act, is mandatory. Performance and payment bonds are required to be furnished in accordance with Chapter 2253 of the Texas Government Code. Bidder should familiarize itself with the entire provisions of Chapter 2253 of the Texas Government Code.

40. PATENT AND COPYRIGHT PROTECTION

The Bidder agrees at its sole expense to protect the County from claims involving infringement of patents, copyright, trademark, trade secret, or other intellectual property rights. **Bidder shall indemnify and save harmless the County of Galveston, its officers, employees, and agents, from liability of any nature and kind whatsoever, including without limitation cost and expenses, for or on account of any copyrighted, trademarked, trade secret, patented or un-patented invention, process, or article manufactured or used in the performance of the contract, or other intellectual property rights, including its use by the County.** Bidder also agrees that if Bidder is awarded this contract, that no work performed hereunder shall be subject to patent, copyright, or other intellectual property by Bidder.

41. CONFLICT OF INTEREST DISCLOSURE REPORTING (FORM CIQ)

Bidder may be required under Chapter 176 of the Texas Local Government Code to complete and file a conflict of interest questionnaire (CIQ Form). The CIQ Form pertains to business relationship, gift giving and family relationship reporting. If bidder is required to file a CIQ Form, then the completed CIQ Form must be filed with the County Clerk of Galveston County, Texas.

Business relationship. If Bidder has an employment or other business relationship with a local government officer of Galveston County or with a family member of a local government officer of Galveston County that results in the officer or family member of the officer receiving taxable income that exceeds \$2,500.00 during the preceding 12-month period, then Bidder **MUST** complete a CIQ Form and file the original of the CIQ Form with the County Clerk of Galveston County.

Gift-giving. If Bidder has given a local government officer of Galveston County or a family member of a local government officer of Galveston County one or more gifts with an aggregate value of more than one-hundred dollars

**GENERAL PROVISIONS – INVITATION TO BID
JERRY J. ESMOND JUVENILE JUSTICE CENTER ROOF REPLACEMENT
GALVESTON COUNTY, TEXAS**

(\$100.00) during the preceding 12-months, then Bidder **MUST** complete a CIQ Form and file the original of the CIQ Form with the County Clerk of Galveston County.

Family member. For purposes of the business relationship and gift giving reporting requirements, a “family member” means a person related to another person with the first degree of consanguinity or affinity, as described by Subchapter B, Chapter 573, Texas Government Code. Examples of persons within the first degree by consanguinity or affinity include a son, daughter, father, mother, spouse, son-in-law, daughter-in-law, father-in-law, mother-in-law, stepson, stepdaughter, stepmother, and stepfather.

Family relationship. If Bidder has a “family relationship” with a local government officer of Galveston County then Bidder **MUST** complete a CIQ Form and file the original of the CIQ Form with the County Clerk of Galveston County, regardless of whether Bidder has a business relationship or has given gifts to the local government officer or a family member of the local government officer. For this purpose, “family relationship” means Bidder is related within the third degree by consanguinity or the second degree by affinity, as those terms are defined under Chapter 573 of the Texas Government Code, to a local government officer of Galveston County. Examples of such relationships include a son, daughter, mother, father, brother, sister, grandchild, great-grandchild, grandparent, great-grandparent, niece, nephew, uncle, aunt, spouse, mother-in-law, father-in-law, daughter-in-law, son-in-law, spouse’s grandchild, spouse’s grandparent, grandparent’s spouse, grandchild’s spouse, stepson, stepdaughter, stepmother, and stepfather.

Bidder must file its original CIQ Form with the Galveston County Clerk. The Galveston County Clerk has offices at the following locations:

Galveston County Clerk
Galveston County Justice Center, Suite 2001
600 59th Street
Galveston, Texas 77551

Galveston County Clerk
North County Annex, 1st Floor
174 Calder Road
League City, Texas 77573

Again, if Bidder is required to file a CIQ Form, the original completed form is filed with the Galveston County Clerk (**not the Purchasing Agent**).

For Bidder’s convenience, a blank CIQ Form is enclosed with this bid package. Blank CIQ Form(s) may also be obtained by visiting the Purchasing Agent’s website – this website is linked from the Galveston County homepage, at <http://www.galvestoncountytexas.gov>.

Chapter 176 specifies deadlines for the filing of CIQ Forms (both initial filings and updated filings).

It is Bidder’s sole responsibility to file a true and complete CIQ Form with the Galveston County Clerk if Bidder is required to file by the requirements of Chapter 176 of the Local Government Code. Bidder is advised that it is an offense to fail to comply with the disclosure reporting requirements dictated under Chapter 176 of the Texas Local Government Code, and the failure to file may be grounds to void the contract, if Bidder is awarded a contract.

If bidder has any questions about compliance with Chapter 176, Bidder may wish to consult its’ legal counsel. Compliance is the individual responsibility of each person, business, and agent who is subject to Chapter 176 of the Texas Local Government Code.

**GENERAL PROVISIONS – INVITATION TO BID
JERRY J. ESMOND JUVENILE JUSTICE CENTER ROOF REPLACEMENT
GALVESTON COUNTY, TEXAS**

42. DISCLOSURE OF INTERESTED PARTIES/FORM 1295

Under Section 2252.908 of the Government Code, any business entity that enters into a contract with Galveston County that requires the approval of the Commissioners Court must submit a “Disclosure of Interested Parties” to the County prior to the execution of the contract. This form, the “Disclosure of Interested Parties” form was promulgated by the Texas Ethics Commission, and is the “Form 1295”. **This procurement is subject to these requirements.**

The Texas Ethics Commission was charged with promulgating rules to implement Section 2252.908 of the Government Code. The rules adopted by the Texas Ethics Commission are located at Sections 46.1, 46.3, and 46.5 of Title 1 of the Texas Administrative Code. Thus, the law covering these requirements is located at Section 2252.908 of the Government Code, and in Title 1, Sections 46.1, 46.3, and 46.5 of the Texas Administrative Code.

The Texas Ethics Commission’s website is: www.ethics.state.tx.us. The area of the Texas Ethics Commission website pertaining to Form 1295 is:

www.ethics.state.tx.us/whatsnew/elf_info_form1295.htm.

Form 1295 must be completed electronically through the Texas Ethics Commission website (handwritten forms are not allowable). Once the business entity has completed their electronic filing of Form 1295, then the business entity must print out the electronically completed form, and sign and notarize the Form 1295. Once Form 1295 is signed and notarized, the business entity must submit their completed, signed, and notarized Form 1295 to the Galveston County Purchasing Agent.

Successful Proposer is and shall be subject to these requirements, and no resultant contract may be executed by the Commissioners Court until the completed, signed, and notarized Form 1295 is on file with the County Purchasing Agent.

No portion of the Form 1295 process commits the County to any type of award of contract whatsoever.

After the Purchasing Agent’s Office receives the completed, signed, and notarized Form 1295, the Purchasing Agent’s Office will, within 30 days, go the Texas Ethics Commission website to submit electronic confirmation of the County’s receipt of the completed, signed, and notarized Form 1295.

43. CERTIFICATION REGARDING DEBARMENT, SUSPENSION, PROPOSED DEBARMENT, AND OTHER RESPONSIBILITY MATTERS & REQUIREMENT TO REGISTER IN SAM

Bidder certifies that neither it, nor any of its Principals, are presently debarred, suspended, proposed for debarment, disqualified, excluded, or in any way declared ineligible for the award of contracts by any Federal agency. Contractor agrees that it shall refund Galveston County for any payments made to Contractor while ineligible. Contractor acknowledges that Contractor’s uncured failure to perform under this Agreement, if such should occur, may result in Contractor being debarred from performing additional work for the County, the respecting State Agency administering the grant funding the contract, if applicable, the State, FEMA or HUD (as applicable), and other Federal and State entities. Further, Bidder has executed the Certification Regarding Debarment, Suspension, Proposed Debarment, and Other Responsibility Matters and returned the fully completed and executed original certification with the submission of its bid. **The truthful and fully completed and executed original of the Certification Regarding Debarment, Suspension, Proposed Debarment, and Other Responsibility Matters must be included with the submission of Bidder’s Bid and is a mandatory requirement of this Invitation to Bid. Bidder’s failure to include the fully completed and executed original of this Certification shall be considered non-compliance with the requirements of this Invitation to Bid and grounds for the rejection of Bidder’s Bid.** Proposer shall immediately notify the County Purchasing Agent if it becomes debarred or suspended, placed on the Consolidated List of Debarred

**GENERAL PROVISIONS – INVITATION TO BID
JERRY J. ESMOND JUVENILE JUSTICE CENTER ROOF REPLACEMENT
GALVESTON COUNTY, TEXAS**

Contractors, or in any other way becomes ineligible for award of contract by any Federal agency. This Certification is a material fact relied upon by Galveston County; if it is later determined that the contractor did not comply with 2 C.F.R. Part 180 and 2 C.F.R. Part 3000, in addition to the remedies available to Galveston County and the State agency administering this grant, the Federal Government may pursue available remedies, including but not limited to suspension and/or debarment of contractor.

If the contract to be awarded pursuant to this procurement involves the use of Federal funds, then bidder must also be registered in the Federal Contractor Registry through the System for Award Management (SAM) to be eligible for award of contract pursuant to this procurement.

Information regarding the SAM is available at:

<http://www.federalcontractorregistry.com/?gclid=CIG1hf2rr8wCFYkCaQoducANZw> or at
<https://www.sam.gov/portal/SAM/#1>.

No contract involving the use of Federal funds may be awarded to any bidder unless and until such registration is current and in good standing under SAM. Successful bidder must maintain SAM registration throughout the entire term of the agreement with the County. If this contract involves the use of Federal funds, then bidder must enclose proof of such SAM registration within its response, which is also a mandatory requirement of this procurement; failure to enclose such proof shall be considered non-compliance with the requirements of this procurement and grounds for the rejection of bidder's response to this procurement (i.e., bid, proposal, or qualifications statement, as applicable).

44. SOVEREIGN IMMUNITY

The County specifically reserves any claim it may have to sovereign, qualified, or official immunity as a defense to any action arising in conjunction with this contract.

45. CONTROLLING LAW AND VENUE

Bidder acknowledges and agrees that the contract is and shall be governed and construed by the laws of the State of Texas and that venue shall lie exclusively in a court of competent jurisdiction in Galveston County, Texas.

46. MERGERS, ACQUISITIONS

The Bidder shall be required to notify the County of any potential for merger or acquisition of which there is knowledge at the time that a bid is submitted.

If subsequent to the award of any contract resulting from this Invitation to Bid the Bidder shall merge or be acquired by another firm, the following documents must be submitted to the County:

- A. Corporate resolutions prepared by the awarded Bidder and the new entity ratifying acceptance of the original contract, terms, conditions and prices;
- B. New entity's Federal Identification Number (FEIN);
- C. New entity's proposed operating plans;
- D. New entity's proof of registration in SAM for contracts involving Federal funds;
- E. New entity's certification regarding debarment;

**GENERAL PROVISIONS – INVITATION TO BID
JERRY J. ESMOND JUVENILE JUSTICE CENTER ROOF REPLACEMENT
GALVESTON COUNTY, TEXAS**

- F. New entity's certification regarding lobbying; and
- G. W-9 Form for new entity.

Moreover, Bidder is required to provide the County with notice of any anticipated merger or acquisition as soon as Bidder has actual knowledge of the anticipated merger or acquisition. The New Bidder's proposed plan of operation must be submitted prior to merger to allow time for submission of such plan to the Commissioners Court for its approval.

47. DELAYS

The County reserves the right to delay the scheduled commencement date of the contract if it is to the advantage of the County. There shall be no additional costs attributed to these delays should any occur. Bidder agrees it will make no claims for damages, for damages for lost revenues, for damages caused by breach of contract with third parties, or any other claim by Bidder attributed to these delays, should any occur. In addition, Bidder agrees that any contract it enters into with any third party in anticipation of the commencement of the contract will contain a statement that the third party will similarly make no claim for damages based on delay of the scheduled commencement date of the contract.

48. ACCURACY OF DATA

Information and data provided through this Invitation to Bid are believed to be reasonably accurate.

49. SUBCONTRACTING/ASSIGNMENT

Bidder shall not assign, sell, or otherwise transfer its contract in whole or in part without prior written permission of the County acting by and through its Commissioners' Court. Such consent, if granted, shall not relieve the Bidder of any of its responsibilities under this contract.

50. INDEPENDENT CONTRACTOR

Bidder expressly acknowledges that it is an independent contractor. Nothing in this agreement is intended nor shall be construed to create an agency relationship, an employer/employee relationship, a joint venture relationship, or any other relationship allowing County to exercise control or direction over the manner or method by which Bidder or its subcontractors perform in providing the requirements stated in the Invitation to Bid.

51. MONITORING PERFORMANCE

The County shall have the unfettered right to monitor and audit the Bidder's work in every respect. In this regard, the Bidder shall provide its full cooperation and insure the cooperation of its employees, agents, assigns, and subcontractors. Further, the Bidder shall make available for inspection and/or copying when requested, original data, records, and accounts relating to the Bidder's work and performance under this contract. In the event any such material is not held by the Bidder in its original form, a true copy shall be provided.

**GENERAL PROVISIONS – INVITATION TO BID
JERRY J. ESMOND JUVENILE JUSTICE CENTER ROOF REPLACEMENT
GALVESTON COUNTY, TEXAS**

52. SUBJECT TO APPROPRIATION OF FUNDS

State law prohibits the obligation and expenditure of public funds beyond the fiscal year for which a budget has been approved by the Commissioners' Court. Galveston County anticipates this to be an integral part of future budgets to be approved during the periods of this contract, except for unanticipated needs or events which may prevent such payments against this contract. However, Galveston County cannot guarantee the availability of funds, and enters into this contract only to the extent such funds are made available through appropriation (allocation) by the Commissioners' Court. This contract shall not be construed as creating any debt on behalf of the County of Galveston in violation of TEX. CONST. art. XI, § 7, and it is understood that all obligations of Galveston County are subject to the availability of funds.

53. CONTRACTS SUBJECT TO GRANT FUNDING

Notwithstanding the foregoing, if the contract to be awarded by this procurement is funded with Federal or State grant funds, the bidder acknowledges that the obligations of the County under the contract are contingent upon the continued availability of grant funding to meet the County's obligations. If the grant(s) to the County is reduced, de-obligated, or otherwise discontinued or terminated, Contractor agrees that the County may immediately terminate the contract without penalty or any liability whatsoever on the part of the County, the State, or the Federal awarding agency.

54. PROCUREMENT ETHICS

Galveston County is committed to the highest ethical standards. Therefore, it is a serious breach of the public trust to subvert the public purchasing process by directing purchases to certain favored vendors, or to tamper with the competitive bidding process, whether it's done for kickbacks, friendship or any other reason. Since misuse of the purchasing power of a local government carries criminal penalties, and many such misuses are from a lack of clear guidelines about what constitutes an abuse of office, the Code of Ethics outlined below must be strictly followed.

Galveston County also requires ethical conduct from those who do business with the County.

CODE OF ETHICS – Statement of Purchasing Policy:

Public employment is a public trust. It is the policy of Galveston County to promote and balance the objective of protecting the County's integrity and the objective of facilitating the recruitment and retention of personnel needed by Galveston County. Such policy is implemented by prescribing essential standards of ethical conduct without creating unnecessary obstacles to entering public office.

Public employees must discharge their duties impartially so as to assure fair competitive access to governmental procurement by responsible contractors. Moreover, they should conduct themselves in such a manner as to foster public confidence in the integrity of the Galveston County procurement organization.

To achieve the purpose of this Article, it is essential that those doing business with Galveston County also observe the ethical standards prescribed herein.

General Ethical Standards:

It shall be a breach of ethics to attempt to realize personal gain through public employment with Galveston County by any conduct inconsistent with the proper discharge of the employee's duties.

It shall be a breach of ethics to attempt to influence any public employee of Galveston County to breach the standards of ethical conduct set forth in this code.

**GENERAL PROVISIONS – INVITATION TO BID
JERRY J. ESMOND JUVENILE JUSTICE CENTER ROOF REPLACEMENT
GALVESTON COUNTY, TEXAS**

It shall be a breach of ethics for any employee of Galveston County to participate directly or indirectly in a procurement when the employee knows that:

- The employee or any member of the employee's family, has a financial interest pertaining to the procurement;
- A business or organization in which the employee or any member of the employee's family, has a financial interest pertaining to the procurement; or
- Any other person, business, or organization with which the employee or any member of the employee's family is negotiating or has an arrangement concerning prospective employment is involved in the procurement.

Gratuities:

It shall be a breach of ethics for any person to offer, give, or agree to give any employee or former employee of Galveston County, or for any employee or former employee of Galveston County to solicit, demand, accept or agree to accept from another person, a gratuity or an offer of employment in connection with any decision, approval, disapproval, recommendation, preparation of any part of a program requirement or a purchase request, influencing the content of any specification or procurement standard, rendering of advice, investigation, auditing, or in any other advisory capacity in any proceeding or application, request for ruling, determination, claim or controversy, or other particular matter, pertaining to any program requirement or a contract or subcontract, or to any solicitation or bid pending before this government.

Kickbacks:

It shall be a breach of ethics for any payment, gratuity or offer of employment to be made by or on behalf of a subcontractor under a contract to the prime contractor or higher tier subcontractor for any contract for Galveston County, or to any person associated therewith, as an inducement for the award of a contract, subcontract or order.

Contract Clause:

The prohibition against gratuities and kickbacks prescribed above shall be conspicuously set forth in every contract and solicitation by Galveston County.

Confidential Information:

It shall be a breach of ethics for any employee or former employee of Galveston County to knowingly use confidential information for actual or anticipated personal gain, or for the actual or anticipated gain of any other person.

Prohibition against Contingent Fees:

It shall be a breach of ethical standards for a person to be retained, or to retain a person, to solicit or secure a Galveston County contract upon an agreement or understanding for a commission, percentage, brokerage, or contingent fee, except for retention of bona fide employees or bona fide established commercial selling agencies for the purpose of securing business. Failure to abide by this section constitutes a breach of ethical standards.

Representation:

Bidder represents and warrants, by signing and submitting its bid, that it has not retained anyone in violation of this section prohibiting contingent fees.

Contract Clause:

The representation prescribed above shall be conspicuously set forth in every contract and solicitation thereof.

55. NON-COLLUSION AFFIDAVIT

**GENERAL PROVISIONS – INVITATION TO BID
JERRY J. ESMOND JUVENILE JUSTICE CENTER ROOF REPLACEMENT
GALVESTON COUNTY, TEXAS**

Bidder certifies, by signing and submitting a bid, that the bid is not made in the interest of, or on behalf of, any undisclosed person, partnership, company, association, organization, or corporation; that the bid is genuine and not collusive or sham; that the contractor has not directly or indirectly induced or solicited another contractor to put in a false or sham bid, and has not directly or indirectly colluded, conspired, connived, or agreed with any contractor or anyone else to put in a sham bid or that anyone shall refrain from bidding; that the contractor has not in any manner, directly or indirectly, sought by agreement, communications, or conference with anyone to fix the bid price of the contractor of any other bidder, or to fix any overhead, profit or cost element of the bid price, or that of any other contractor, or to secure any advantage against the public body awarding the contract or anyone interested in the proposed contract; that all statements contained in the bid are true; and further, that the contractor has not, directly or indirectly, submitted his or her bid price or any breakdown thereof, or the contents thereof, or divulged information or data relative thereto, or paid, and will not pay, any fee to any cooperation, partnership, company association, organization, bid depository, or to any member or agent thereof to effectuate a collusive or sham bid.

A blank Non-Collusion Affidavit is included with this Bid packet. Bidder must enclose a truthful and fully executed original Non-Collusion Affidavit with the submission of its bid. This is a mandatory requirement of this Invitation to Bid. Failure to include the truthfully and fully executed Non-Collusion Affidavit in the submission of its Bid shall be considered non-compliance with the requirements of this Invitation to Bid by the Bidder and grounds for the rejection of Bidder's submission.

No negotiations, decisions, or actions shall be initiated by any company as a result of any verbal discussion with any County employee prior to the opening of responses to this Invitation to Bid.

No officer or employee of the County of Galveston, and no other public or elected official, or employee, who may exercise any function or responsibilities in the review or approval of this undertaking shall have any personal or financial interest, direct or indirect, in any contract or negotiation process thereof. The above compliance request will be part of all County of Galveston contracts for this service.

56. CERTIFICATION REGARDING LOBBYING

Bidder certifies that:

- a. No Federal appropriated funds have been paid or will be paid, by or on behalf of the bidder, to any person for influencing or attempting to influence a department or employee of an agency, a member of Congress, or an employee of a member of Congress in connection with the awarding of any Federal contract, the making of any Federal grant, the making of any Federal loan, the entering into of any cooperative agreement, and the extension, continuation, renewal, amendment, or modification of any Federal contract, grant, loan or cooperative agreement.
- b. If any funds other than federal appropriated funds have been paid or will be paid to any person for influencing or attempting to influence a department or employee of any agency, a member of Congress, a department or employee of congress, or an employee of a member of Congress in connection with this federal contract, grant, loan, or cooperative agreement, the bidder shall complete and submit Standard Form LLL, "Disclosure Form to Report Lobbying", in accordance with its instructions.
- c. Bidder shall require that the language of this certification be included in the award documents for all subawards at all tiers (including subcontracts, subgrants, and contracts under grants, loans, and cooperative agreements) and that all subrecipients shall certify and disclose accordingly.

The truthful and fully completed and executed original of the Certification Regarding Lobbying (included with bid packet) must be included with the submission of Bidder's Bid and is a mandatory requirement of this Invitation to Bid. Bidder's failure to include the fully completed and executed or original of this Certification shall be considered

**GENERAL PROVISIONS – INVITATION TO BID
JERRY J. ESMOND JUVENILE JUSTICE CENTER ROOF REPLACEMENT
GALVESTON COUNTY, TEXAS**

non-compliant with the requirements of this Invitation to Bid and grounds for the rejection of the Bidder's Bid. Submission of the certification is a prerequisite for making or entering into a contract with Bidder and is imposed by Section 1352, Title 31, United States Code. Further, any person who fails to file the required certification shall be subject to a civil penalty of not less than \$10,000 and not more than \$100,000 for each such failure.

57. NON-DISCRIMINATION

- a. **Equal Employment Opportunity:** Bidder will not discriminate against any employee or applicant for employment because of race, color, religion, national origin, sex, disability, genetic information or veteran status. Bidder will take affirmative action to ensure that applicants are employed, and that employees are treated during employment, without regard to their race, color, religion, national origin, sex, disability, genetic information or veteran status. Such action shall include, but not be limited to, the following: employment; upgrading; demotion or transfer; recruitment or recruitment advertising; layoff or termination; rates of pay or other forms of compensation; and selection for training, including apprenticeship. Bidder agrees to post in conspicuous places, available to employees and applicants for employment, notices of employment.

Bidder will, in all solicitation or advertisements for employees placed by or on behalf of Bidder, state that all qualified applicants will receive consideration for employment without regard to race, color, religion, national origin, sex, disability, genetic information, or veteran status.

Bidder will cause the foregoing provisions to be inserted in all subcontracts for any work covered by this Agreement so that such provisions will be binding upon each subcontractor, provided that the foregoing provisions shall not apply to contracts or subcontracts for standard commercial supplies or raw materials.

Bidder will include the provisions herein in every subcontract or purchase order unless exempted.

- b. **Drug Free Work Place Act:** Bidder shall comply with all applicable requirements of the Drug-Free Workplace Act of 1988 (Public Law 100-690, Title V, Subtitle D; 41 U.S.C. § 8102, et seq.) and implementing regulations thereunder.
- c. **Americans with Disabilities Act:** Bidder shall comply with all applicable provisions of the Americans with Disabilities Act of 1990 (Public Law 101-136) and implementing regulations thereunder.
- d. **OSHA Regulations:** Bidder agrees to maintain and to display any applicable materials for its employees in accordance with OSHA regulations.
- e. **Compliance with Immigration Laws and Use of E-Verify:** Bidder agrees to comply with all requirements of the U.S. Immigration Reform and Control Act of 1986, as amended, and any implementing regulations thereto. Bidder further agrees to utilize the E-Verify system through the Department of Homeland Security on its employees. Bidder shall not employ unauthorized aliens, and shall not assign services to be performed to any supplier or subcontractor who are unauthorized aliens. If any personnel performing any services hereunder are discovered to be an unauthorized alien, then Bidder will immediately remove such personnel from performing services hereunder and shall replace such personnel with personnel who are not unauthorized alien(s).
- f. **State and Federal Law Compliance:** Bidder agrees to comply with all other State and Federal laws and regulations applicable to the provision of services under this contract.

GENERAL PROVISIONS – INVITATION TO BID
JERRY J. ESMOND JUVENILE JUSTICE CENTER ROOF REPLACEMENT
GALVESTON COUNTY, TEXAS

58. RECORD RETENTION AND RIGHT TO AUDIT

Bidder shall keep and maintain all records associated with this contract for a minimum of five (5) years from the close of the contract or as required by Federal or State law or regulation, whichever period is longer. If awarded this contract, Bidder shall allow the County reasonable access to the records in Bidder's possession, custody, or control that the County deems necessary to assist it in auditing the services, costs, and payments provided hereunder. If this contract involves the use of Federal or State funds, then Bidder shall also allow reasonable access to representatives of the Office of Inspector General, the General Accounting Office, the State Auditor's Office, and the other Federal and/or State agencies overseeing the funds that such entities deem necessary to facilitate review by such agencies and Bidder shall maintain fiscal records and supporting documentation for all expenditures in a manner that conforms with OMB Circular A-87 (relocated to 2 C.F.R. Part 225) and this contract.

59. TITLE VI ASSURANCES/TxDOT

The County is subject to Title VI of the Civil Rights Act of 1964 and the Federal and State laws and regulations of the United States Department of Transportation and Texas Department of Transportation (TxDOT). Pursuant to these requirements, the County must have its contractors provide required assurances on compliance with non-discrimination by itself and its subcontractors. The Title VI Assurances within this Subsection are not exhaustive – whenever any Federal, State, or Local requirement requires additional clauses, this list shall not be construed as limiting. Contractor agrees as follows:

- (1) **Compliance with Regulations:** The Contractor shall comply with the Regulations relative to nondiscrimination in Federally-assisted programs of the Department of Transportation (hereinafter, DOT) Title 49, Code of Federal Regulations, Part 21, as they may be amended from time to time (hereinafter referred to as the Regulations), which are incorporated herein by reference and made a part of this contract.
- (2) **Non-discrimination:** The Contractor, with regard to the work performed by it during the contract, shall not discriminate on the basis of race, color, national origin, religion, sex, age, disability or Veteran status in the selection and retention of subcontractors, including procurements of materials and leases of equipment. The Contractor shall not participate either directly or indirectly in the discrimination prohibited by Section 21.5 of the Regulations, including employment practices when the contract covers a program set forth in Appendix B of the Regulations.
- (3) **Solicitations for Subcontractors, Including Procurement of Materials and Equipment:** In all solicitations either by competitive bidding or negotiation made by the Contractor for work to be performed under a subcontract, including procurement of materials or leases of equipment, each potential subcontractor or supplier shall be notified by the Contractor of the Contractor's obligations under this contract and the Regulations relative to nondiscrimination on the grounds of race, color, national origin, religion, sex, age, disability or Veteran status.
- (4) **Information and Reports:** The Contractor shall provide all information and reports required by the Regulations or directives issued pursuant thereto, and shall permit access to its books, records, accounts, other sources of information and its facilities as may be determined by the Galveston County or the Texas Department of Transportation to be pertinent to ascertain compliance with such Regulations, orders and instructions. Where any information required of the Contractor is in the exclusive possession of another who fails or refuses to furnish this information the Contractor shall so certify to Galveston County or the Texas Department of Transportation as appropriate, and shall set forth what efforts it has made to obtain the information.
- (5) **Sanctions for Non-compliance:** In the event of the Contractor's noncompliance with the nondiscrimination provisions of this contract, Galveston County shall impose such contract sanctions as it or the Texas Department of Transportation may determine to be appropriate, including, but not limited to:

GENERAL PROVISIONS – INVITATION TO BID
JERRY J. ESMOND JUVENILE JUSTICE CENTER ROOF REPLACEMENT
GALVESTON COUNTY, TEXAS

- (a) withholding of payments to the Contractor under the contract until the Contractor complies, and/or;
- (b) cancellation, termination, or suspension of the contract, in whole or in part.

(6) Incorporation of Provisions. The Contractor shall include the provisions of paragraphs (1) through (6) in every subcontract, including procurement of materials and leases of equipment, unless exempt by the Regulations, or directives issued pursuant thereto. The Contractor shall take such action with respect to any subcontract or procurement as Galveston County or the Texas Department of Transportation may direct as a means of enforcing such provisions including sanctions for non-compliance: Provided, however, that, in the event Contractor becomes involved in, or is threatened with, litigation with a subcontractor or supplier as a result of such direction, the Contractor may request Galveston County to enter into such litigation to protect the interests of Galveston County, and, in addition, the Contractor may request the United States to enter into such litigation to protect the interests of the United States.

60. SECTION 231.006, FAMILY CODE/DELINQUENT CHILD SUPPORT

Pursuant to Title 5, Section 231.006 of the Texas Family Code, as applicable, Bidder certifies that it, including all of its principals, is/are current in child support payments and that it is eligible to receive payments from State funds under a contract for property, materials, or services. Bidder acknowledges and agrees that if it is awarded this contract, then the ensuing agreement may be terminated and payment withheld if this certification is inaccurate. Finally, by the submission of its bid, the Bidder certifies that it has included the names and social security numbers of each person with at least 25% ownership interest in Bidder within its response to the Invitation to Bid and that all such persons are current in child support payments.

61. ANTITRUST

Pursuant to 15 U.S.C. § 1, et seq., and Texas Business and Commerce Code, Chapter 15, Contractor, by the submission of its bid, certifies that neither Contractor nor any natural person, proprietorship, firm, corporation, partnership, association, or institution represented by Contractor or anyone acting for such natural person, proprietorship, firm, corporation, partnership, association, or institution has violated any Federal or State antitrust laws or communicated the nature of the offer, directly or indirectly, to any competitor or other person engaged in a similar line of business.

62. LABOR STANDARDS

On contracts funded under a federal grant: Bidder acknowledges that the contract to be awarded pursuant to this solicitation is on a grant program funded with Federal funds. Bidder shall comply with the requirements of 29 CFR Part 5 and Part 30 and shall be in conformity with Executive Order 11246, entitled "Equal Employment Opportunity", Copeland, "Anti-Kickback" Act (40 U.S.C. 3145, 29 C.F.R. Part 3), the Davis-Bacon and Related Acts (40 U.S.C. 3141-3148, 29 C.F.R. Parts 1,3, and 5), the Contract Work Hours and Safety Standards Act (40 U.S.C. 3701 et seq.), and all other applicable Federal, State, and local laws and regulations pertaining to labor standards, insofar as those acts apply to the performance of this Agreement. Bidder is also responsible for ensuring that all subcontractors comply with the requirements of 29 CFR Part 5 and Part 30 and shall be in conformity with Executive Order 11246, entitled "Equal Employment Opportunity", Copeland "Anti-Kickback" Act, the Davis-Bacon and Related Acts (29 CFR Parts 1, 3 and 5), the Contract Work Hours and Safety Standards Act (40 U.S.C. 3701 et seq.), and all other applicable Federal, State, and local laws and regulations pertaining to labor standards, insofar as those acts apply to the performance of this Agreement.

GENERAL PROVISIONS – INVITATION TO BID
JERRY J. ESMOND JUVENILE JUSTICE CENTER ROOF REPLACEMENT
GALVESTON COUNTY, TEXAS

63. PROCUREMENT LAWS

- a. Bidder shall comply with all applicable local, State, and Federal procurement laws, rules, and regulations.
- b. If this contract is made pursuant to a federal award, then Contractor acknowledges that the contract is subject, without limitation, to applicable provisions within 2 C.F.R. Part 200, Uniform Administrative Requirements, Cost Principles, and Audit Requirements for Federal Awards. Contractor shall comply with applicable provisions within 2 C.F.R., Sections 200.319 through 200.326, including but not limited to the following:
 - 1.) **Equal Employment Opportunity**, 41 C.F.R. Part 60-1.4(b) (applicable to federally assisted construction contracts).
 - (a) During the performance of this contract, the contractor agrees as follows:
 - (1) The contractor will not discriminate against any employee or applicant for employment because of race, color, religion, sex, national original, disability, or veteran status. The contractor will take affirmative action to ensure that applicants are employed, and that employees are treated during employment, without regard to their race, color, religion, sex, national original, disability or veteran status. Such action shall include, but not be limited to the following: employment, upgrading, demotion, or transfer; recruitment or recruitment advertising; layoff or termination; rates of pay or other forms of compensation; and selection for training, including apprenticeship. The contractor agrees to post in conspicuous places, available to employees and applicants for employment, notices to be provided setting forth the provisions of this nondiscrimination clause.
 - (2) The contractor will, in all solicitations or advertisements for employees placed by or on behalf of contractor, state that all qualified applicants will receive consideration for employment without regard to race, color, religion, sex, national original, disability, or veteran status.
 - (3) The contractor will send to each labor union or representative of workers with which he has a collective bargaining agreement or other contract or understanding, a notice to be provided advising the said labor union or workers' representatives of the contractor's commitments under this section, and shall post copies of the notice in conspicuous places available to employees and applicants for employment.
 - (4) The contractor will comply with all provisions of Executive Order 11246 of September 24, 1965, and by rules, regulations, and relevant orders of the Secretary of Labor.
 - (5) The contractor will furnish all information and reports required by Executive Order 11246 of September 24, 1965, and by rules, regulations, and orders of the Secretary of Labor, or pursuant thereto, and will permit access to contractor's books, records, and accounts by the administering agency and the Secretary of Labor for purposes of investigation to ascertain compliance with such rules, regulations, and orders.
 - (6) In the event of the contractor's noncompliance with the nondiscrimination clauses of this contract or with any of the said rules, regulations, or orders, this contract may be cancelled, terminated, or suspended in whole or in part and the contractor may be declared ineligible for further Government contracts or federally assisted construction contracts in accordance with procedures authorized in Executive Order 11246 of September 24, 1965, and such other sanctions as may be imposed and remedies invoked as provided in Executive Order 11246 of September 24, 1965, or by rule, regulation, or order of the Secretary of Labor, or as otherwise provided by law.
 - (7) The contractor will include the portion of the sentence immediately preceding paragraph (1) and the provisions of paragraphs (1) through (7) in every subcontract or purchase order unless exempted by rules, regulations, or orders of the Secretary of Labor issued pursuant to section 204 of Executive Order 11246 of September 24, 1965, so that such provisions will be binding upon each subcontractor or vendor. The

GENERAL PROVISIONS – INVITATION TO BID
JERRY J. ESMOND JUVENILE JUSTICE CENTER ROOF REPLACEMENT
GALVESTON COUNTY, TEXAS

contractor will take such action with respect to any subcontract or purchase order as the administering agency may direct as a means of enforcing such provisions, including sanctions for noncompliance: Provided, however, that in the event a contractor becomes involved in, or is threatened with, litigation with a subcontractor or vendor as a result of such direction by the administering agency, the contractor may request the United States to enter into such litigation to protect the interests of the United States.

- 2.) **Small and minority business, women’s business enterprises, and labor surplus area firms (2 C.F.R. § 200.321).** The County is required to take affirmative steps to assure that minority businesses, women’s business enterprises, and labor surplus area firms are used when possible. This includes requiring the prime contractor, if subcontracts are to be let in the performance of this contract, to itself take affirmative steps in letting the subcontract. Accordingly, if subcontracts are to be let in the performance of this contract, the contractor must take affirmative steps in the letting of the subcontract(s), which must include:
- (a) placing qualified small and minority businesses and women’s business enterprises on solicitation lists;
 - (b) assuring that small and minority businesses, and women’s business enterprises are solicited whenever they are potential sources;
 - (c) dividing total requirements, when economically feasible, into smaller tasks or quantities to permit maximum participation by small and minority businesses, and women’s business enterprises; and
 - (d) using the services and assistance, as appropriate, of such organizations as the Small Business Administration and the Minority Business Development Agency of the Department of Commerce.

In accordance with FEMA procurement guidance:

A small business is a business that is independently owned and operated, not dominant in the field of operation in which it is bidding on Galveston County contracts, and qualified as a small business under the Small Business Administration criteria and size standards at 13 C.F.R. Part 121.

A women’s business enterprise is a business enterprise that is: (a) at least 51 percent owned by one or more women or, in the case of a publicly owned business, at least 51 percent of the stock is owned by one or more women; and (b) whose management and daily operations are controlled by one or more women.

A minority business is a business that is (a) at least 51 percent owned by one or more minority group members or, in the case of a publicly owned business, at least 51 percent of the stock is owned by one or more minority group members; and (b) whose management and daily operations are controlled by one or more minority group members.

- 3.) **Davis-Bacon Act as amended (40 U.S.C. 3141-3148).** When required by Federal program legislation, all prime construction contracts in excess of \$2,000 must include a provision for compliance with the Davis-Bacon Act as supplemented by the Department of Labor regulations (29 C.F.R. Part 5, “Labor Standards Provisions Applicable to Contracts Covering Federally Financed and Assisted Construction”). In accordance with the statute, contractor must be required to pay wages to laborers and mechanics at a rate not less than the prevailing wages specified in a wage determination made by the Secretary of Labor. In addition, contractors must be required to pay wages not less than once a week. The non-Federal entity (the County) must place a copy of the current prevailing wage determination issued by the Department of Labor in each solicitation. The decision to award a contract or subcontract must be condition upon the acceptance of the wage determination. The non-Federal entity must report all suspected or reported violations to the Federal awarding agency. The contract must also include a provision for compliance with the Copeland Anti-Kickback Act (40 U.S.C. § 3145) as supplemented by the Department of Labor regulations (29 C.F.R. Part 3, “Contractors and Subcontractors on Public Building or Public Work Financed in Whole or in Part by Loans or Grants from the United States”).

GENERAL PROVISIONS – INVITATION TO BID
JERRY J. ESMOND JUVENILE JUSTICE CENTER ROOF REPLACEMENT
GALVESTON COUNTY, TEXAS

- 4.) **Compliance with the Copeland “Anti-Kickback” Act.** Contractor is prohibited from inducing, by any means, any person employed in the construction, completion, or repair of public work, to give up any part of the compensation to which the person is otherwise entitled. The non-Federal entity must report all suspected or reported violations to the Federal awarding agency. “Whoever, by force, intimidation, or threat of procuring dismissal from employment, or by any other manner whatsoever induces any person employed in the construction, prosecution, completion or repair of any public building, public work, or building or work financed in whole or in part by loans or grants from the United States, to give up any part of the compensation to which he is entitled under his contract of employment, shall be fined under this title [Title 18, U.S.C.] or imprisoned not more than five years, or both.” 18 U.S.C. § 874.
- (a) Contractor shall comply with 18 U.S.C. § 874, 40 U.S.C. § 3145, and the requirements of 29 C.F.R. Part 3 as may be applicable, which are incorporated by reference into this contract.
 - (b) The contractor or subcontractor shall insert in any subcontracts the clause above and such other clauses as the Federal awarding agency may be appropriate instructions require, and also a clause requiring the subcontractors to include these clauses in any lower tier subcontracts. The prime contractor shall be responsible for the compliance by any subcontractor or lower tier subcontractor with all of these contract clauses.
 - (c) Breach. A breach of the contract clause above may be grounds for termination of the contract, and for debarment as a contractor and subcontractor as provided in 29 C.F.R. § 5.12.
- 5.) **Contract Work Hours and Safety Standards Act.**
- (a) Where applicable, all contracts awarded by the County in excess of \$100,000 that involve the employment of mechanics or laborers must include a provision for compliance with 40 U.S.C. §§ 3702 and 3704, as supplemented by the Department of Labor regulations at 29 C.F.R. Part 5. Under 40 U.S.C. 3702 of the Contract Work Hours and Safety Standards Act, each contractor must be required to compute the wages of every mechanic and laborer on the basis of a standard work week of 40 hours. Work in excess of the standard work week is permissible provided that the worker is compensated at a rate of not less than one and a half times the basic rate of pay for all hours worked in excess of 40 hours in the work week. The requirements of 40 U.S.S. 3704 are applicable to construction work and provide that no laborer or mechanic must be required to work in surroundings or under working conditions which are unsanitary, hazardous or dangerous. These requirements do not apply to the purchase of supplies or material or articles ordinarily available on the open market, or contractors for transportation or transmission of intelligence.
 - (b) Compliance with the Contract Work Hours and Safety Standards Act.
 - (1) Overtime requirements. No contractor or subcontractor contracting for any part of the contract work which may require or involve the employment of laborers or mechanics shall require or permit any such laborer or mechanic in any workweek in which he or she is employed on such work to work in excess of forty hours in such workweek unless such laborer or mechanic receives compensation at a rate not less than one and one-half times the basic rate of pay for all hours worked in excess of forty hours in such workweek.
 - (2) Violation; liability for unpaid wages; liquidated damages. In the event of any violation of the clause set forth in paragraph (1) of this subsection the contractor and any subcontractor responsible therefor shall be liable for the unpaid wages. In addition, such contractor and subcontractor shall be liable to the United States (in the case of work done under contract for the District of Columbia or a territory, to such District or to such territory), for liquidated damages. Such liquidated damages shall be computed with respect to each individual laborer or mechanic, including watchmen and guards, employed in violation of the clause set forth in paragraph (1) of this subsection, in the sum of \$10 for each calendar day on which such individual was required or permitted to work in excess of the standard work week of forty hours without payment of the overtime wages required by the clause set forth in paragraph (1) of this subsection.

GENERAL PROVISIONS – INVITATION TO BID
JERRY J. ESMOND JUVENILE JUSTICE CENTER ROOF REPLACEMENT
GALVESTON COUNTY, TEXAS

- (3) Withholding for unpaid wages and liquidated damages. The awarding Federal agency, State agency, or the County shall upon its own action or upon written request of an authorized representative of the Department of Labor withhold or cause to be withheld, from any moneys payable on account of work performed by the contractor or subcontractor under any such contract or any other Federal contract with the same prime contractor, or any other federally-assisted contract subject to the Contract Work Hours and Safety Standards Act, which is held by the same prime contractor, such sums as may be determined to be necessary to satisfy any liabilities of such contractor or subcontractor for unpaid wages and liquidated damages as provided in the clause set forth in paragraph (2) of this subsection.
- (4) Subcontracts. The contractor or subcontractor shall insert in any subcontracts the clauses set forth in paragraph (1) through (4) of this subsection and also a clause requiring the subcontractors to include these clauses in any lower tier subcontracts. The prime contractor shall be responsible for compliance by any subcontractor or lower tier subcontractor with the clauses set forth in paragraphs (1) through (4) of this subsection.
- 6.) Rights to Inventions Made Under a Contractor Agreement.**
- (a) If the Federal award meets the definition of “funding agreement” under 37 C.F.R. § 401.2(a) and the recipient or subrecipient wishes to enter into a contract with a small business firm or nonprofit organization regarding the substitution of parties, assignment or performance of experimental, developmental, or research work under the “funding agreement,” the recipient or subrecipient must comply with the requirements of 37 C.F.R. Part 401, “Rights to Inventions Made by Nonprofit Organizations and Small Business Firms Under Government Grants, Contracts and Cooperative Agreements,” and any implementing regulations issued by the awarding agency.
- (b) Stafford Act Disaster Grants. This requirement does not apply to Public Assistance, Hazard Mitigation Grant Program, Crisis Counseling Assistance and Training Grant program, Disaster Case Management Grant Program, and Federal Assistance to Individuals and Households – Other Needs Assistance Grant Program, as FEMA awards under these programs do not meet the definition of “funding agreement.”
- (c) The regulations and 37 C.F.R. § 401.2(a) currently defines “funding agreement” as any contract, grant, or cooperative agreement entered into between any Federal agency, other than the Tennessee Valley Authority, and any contractor for the performance of experimental, developmental, or research work funded in whole or in part by the Federal government. This term also includes any assignment, substitution of parties, or subcontract of any type entered into for the performance of experimental, developmental, or research work under a funding agreement as defined in the first sentence of this paragraph.
- 7.) Clean Air Act (42 U.S.C. §§ 7401 – 7671q) and the Federal Water Pollution Control Act 933 U.S.C. §§ 1251-1387), as amended.**
- (a) The contractor agrees to comply with all applicable standards, orders or regulations issued pursuant to the Clean Air Act, as amended, 42 U.S.C. § 7401, et seq., and agrees to comply with all applicable standards, orders, or regulations issued pursuant to the Federal Water Pollution Contract Act, as amended, 33 U.S. C. § 1251, et seq.
- (b) The contractor agrees to report each violation of the Clean Air Act and/or the Federal Water Pollution Control Act to the Federal awarding agency, the State agency administering the grant, and the Regional Office of the Environmental Protection Agency (EPA) and understands and agrees that the Federal awarding agency, the State agency, and the EPA will, in turn, report each violation as required to assure notification to Galveston County, the Federal Emergency Management Agency, and the appropriate EPA Regional Office.

GENERAL PROVISIONS – INVITATION TO BID
JERRY J. ESMOND JUVENILE JUSTICE CENTER ROOF REPLACEMENT
GALVESTON COUNTY, TEXAS

- 8.) **Debarment and Suspension (Executive Orders 12549 and 12689).** A contract award must not be made to parties listed on the government-wide exclusions in the System for Award Management (SAM), in accordance with the OMB guidelines at 2 C.F.R. Part 180 that implement Executive Orders 12549 and 12689. The Contractor is required to verify that none of the contractor, its principals (defined at 2 C.F.R. § 180.995), or its affiliates (defined at 2 C.F.R. § 180.905) are excluded (defined at 2 C.F.R. § 180.940) or disqualified (defined at 2 C.F.R. § 180.935).

Contractor must comply with 2 C.F.R. Part 180, Subpart C and 2 C.F.R. Part 3000, Subpart C, and must include a requirement to comply with these regulations in any lower tier covered transaction it enters into. Bidder agrees to comply with the requirements of 2 C.F.R. Part 180, Subpart C, and 2 C.F.R. Part 3000, Subpart C, while this offer is valid and through the period of any contract that may arise from this offer. The bidder further agrees to include a provision requiring such compliance in its lower tier covered transactions.

9.) **Procurement of Recovered Materials.**

- (a.) A non-Federal entity that is a State agency or agency of a political subdivision of the State and its contractors must comply with Section 6002 of the Solid Waste Disposal Act, Public Law No. 89-272 (1965) (codified as amended by the Resource Conservation and Recovery Act at 42 U.S.C. § 6962).
- (b.) In the performance of this contract, the contractor shall make maximum use of products containing recovered materials that are EPA-designated items unless the product cannot be acquired—
- (1) Competitively within a timeframe providing for compliance with the contract performance schedule;
 - (2) Meeting contract performance requirements; or
 - (3) At a reasonable price.
- (c) Information about this requirement is available at EPA's Comprehensive Procurement Guidelines website, <http://www.epa.gov/cpg/>. The list of EPA-designated items is available at <https://www.epa.gov/cpg/products.htm>.

In the event of any discrepancy between the provisions in this Section 61 of General Provisions and provisions on the same subject elsewhere within this procurement, the most stringent shall control.

64. ENTIRETY OF AGREEMENT AND MODIFICATION

This contract contains the entire agreement between the parties. Any prior agreement, promise, negotiation or representation not expressly set forth in this contract has no force or effect. Any subsequent modification to this contract must be in writing, signed by both parties.

An official representative, employee, or agent of the County does not have the authority to modify or amend this contract except pursuant to specific authority to do so granted by the Galveston County Commissioners' Court.

65. NOTICE

All notices or other communications required or permitted under this contract shall be in writing and shall be deemed to have been duly given if delivered personally in hand, transmitted by facsimile, or mailed certified mail, return receipt requested with proper postage affixed and addressed to the appropriate party at the following address or at such other address as may have been previously given in writing to the parties (Bidder shall provide its notice information with its Bid submission). If mailed, the notice shall be deemed delivered when actually received, or if

GENERAL PROVISIONS – INVITATION TO BID
JERRY J. ESMOND JUVENILE JUSTICE CENTER ROOF REPLACEMENT
GALVESTON COUNTY, TEXAS

earlier, on the third day following deposit in a United States Postal Service post office or receptacle, duly certified, return receipt requested, with proper postage affixed. If delivered in person, notice shall be deemed delivered when receipted for by, or actually received by, the receiving Party. If transmitted by facsimile, notice shall be deemed delivered when receipt of such transmission is acknowledged.

To the County at:

Hon. Mark Henry,
County Judge of Galveston County
722 Moody (21st Street), Second (2nd) Floor
Galveston, Texas 77550
Fax: (409) 765-2653

With copies to:

Rufus Crowder, CPPO CPPB,
Galveston County Purchasing Agent
722 Moody (21st Street), Fifth (5th) Floor
Galveston, Texas 77550
Fax: (409) 621-7997

To the Contractor at:

(Bidder to provide its contact name, address, and facsimile number for notice under the contract.)

66. USE OF DHS SEAL, LOGO, AND FLAGS PROHIBITED WITHOUT PRIOR APPROVAL

Contractor must obtain permission from the U.S. Department of Homeland Security financial assistance office (DHS FAO) **prior** to using DHS seals(s), logos, crests, or reproductions of flags or likenesses of DHS agency officials, including use of the United States Coast Guard seal, logo, crests or reproductions of flags or likenesses of Coast Guard Officials.

67. FEDERAL GOVERNMENT NOT A PARTY

Contractor acknowledges that the Federal Government is not a party to the contract and is not subject to any obligations or liabilities to Galveston County, contractor, or any other party pertaining to any matter resulting from the contract.

68. PROGRAM FRAUD AND FALSE OR FRAUDULENT STATEMENTS OR RELATED ACTS

In contracts funded through Federal grants, Contractor acknowledges that 31 U.S.C. Chapter 38, Administrative Remedies for False Claims and Statements (31 U.S.C. § 3801, et seq.) and the implementing regulations thereunder, 49 C.F.R. Part 79, apply to Contractors actions pertaining to the contract.

**GENERAL PROVISIONS – INVITATION TO BID
JERRY J. ESMOND JUVENILE JUSTICE CENTER ROOF REPLACEMENT
GALVESTON COUNTY, TEXAS**

69. LEAD AND ASBESTOS

If this invitation to bid involves remediation, demolition, reconstruction, rehabilitation, repair, or construction, or other applicable activities, the Contractor shall be responsible for performing investigations of lead and asbestos containing materials, and any required lead and asbestos abatement in compliance with Federal, State, and local laws, rules, regulations, ordinances and orders, relating to lead abatement and asbestos abatement as applicable, including but not limited to the Texas Asbestos Health Protection Act, codified as Chapter 1954 of the Occupations Code; the Texas Asbestos Health Protection Regulations, located at Title 25, Part 1, Chapter 295, Subchapter C of the Texas Administrative Code; Chapter 1955 of the Texas Occupations Code (lead-based paint abatement); the Texas Environmental Lead Reduction regulations, located at Title 25, Part 1, Chapter 295, Subchapter I of the Texas Administrative Code; the federal National Emission Standards for Asbestos regulations, located at Title 40, Part 61, Subpart M of the Code of Federal Regulations, and the National Emission Standards for Hazardous Air Pollutants. Contractor shall perform such inspections, encapsulation, remediation or other actions as required by federal, State, or local requirements in accordance with the federal Environmental Protection Agency (EPA), Texas Department of State Health Services (TXDSHS), and Texas Commission on Environmental Quality (TCEQ) requirements.

70. ACKNOWLEDGMENT OF GOVERNMENT RECORD

Bidder acknowledges that its submission in this Invitation to Bid, including its response, bid, certifications, affidavits, Vendor Forms (i.e., PEID, W-9, CIQ, etc.) constitutes government records under Chapter 37 of the Texas Penal Code.

71. COMPLIANCE WITH GALVESTON COUNTY PURCHASING POLICIES AND PROCEDURES

Bidder acknowledges, by its submission in this Invitation to Bid, that it shall comply with the Galveston County Purchasing Policies & Procedures Manual approved by Order of the Galveston County Commissioners Court on March 7, 2018.

End of General Provisions Section

The remainder of this page intentionally left blank

SPECIAL PROVISIONS
JERRY J. ESMOND JUVENILE JUSTICE CENTER ROOF REPLACEMENT
GALVESTON COUNTY, TEXAS

TABLE OF CONTENTS

| | | |
|----|---|-----|
| A. | PURPOSE | 1 |
| B. | DEFINITIONS | 1 |
| C. | BID SURETY | 1 |
| D. | PERFORMANCE AND PAYMENT BONDS | 1 |
| E. | DAVIS-BACON WAGE RATES | 1 |
| F. | BEST AND FINAL OFFERS (BAFO) | 1 |
| G. | PROCUREMENT TIMELINE | 1 |
| H. | PRE-BID CONFERENCE | 2 |
| I. | SUBMISSION INSTRUCTIONS | 2 |
| J. | PERSONNEL TO CONTACT | 2-3 |
| K. | PROGRAM ADMINISTRATION & CONTRACT MANAGEMENT | 3 |
| L. | TYPE OF CONTRACT | 3 |
| M. | COLLATERAL CONTRACT | 4 |
| N. | LABOR | 4 |
| O. | INSURANCE | 4-5 |
| P. | EXCEPTIONS | 5 |

SPECIAL PROVISIONS
JERRY J. ESMOND JUVENILE JUSTICE CENTER ROOF REPLACEMENT
GALVESTON COUNTY, TEXAS

The Special Provisions and the General Provisions of this Invitation to Bid and the Exhibits attached hereto are made a part of this agreement between the Parties. In the event of a conflict between the General Provisions and the Special Provisions, the terms of the Special Provisions shall control.

A. PURPOSE

Galveston County is seeking a vendor to replace the roof at the Jerry J. Esmond Juvenile Justice Center, located at 6101, Attwater Avenue, Texas City, TX. The existing roof has failed and it has exceeded its useful service life.

B. DEFINITIONS (As mentioned in FAR Subpart 52.2—Text of Provisions and Clauses)

52.202-1 Definitions.

Definitions (Nov 2013)

When a solicitation provision or contract clause uses a word or term that is defined in the Federal Acquisition Regulation (FAR), the word or term has the same meaning as the definition in FAR 2.101 in effect at the time the solicitation was issued, unless—

- (a) The solicitation, or amended solicitation, provides a different definition;
- (b) The contracting parties agree to a different definition;
- (c) The part, subpart, or section of the FAR where the provision or clause is prescribed provides a different meaning; or
- (d) The word or term is defined in FAR Part 31, for use in the cost principles and procedures

C. BID SURETY

A Bid surety/bond is a requirement of this solicitation.

D. PERFORMANCE AND PAYMENT BONDS

Performance and Payment Bonds are a requirement of this solicitation.

E. DAVIS-BACON WAGE RATES

Attention is called to the fact that not less than, the federally determined prevailing (Davis-Bacon and Related Acts) wage rate, as issued by the Office of Rural Community Affairs and contained in the contract documents, must be paid on this project. In addition, the successful bidder must ensure that employees and applicants for employment are not discriminated against because of race, color, religion, sex age or national origin.

F. BEST AND FINAL OFFERS (BAFO)

The Best and Final Offer process **is not applicable** to this solicitation.

G. PROCUREMENT TIMELINE

A timeline for this Bid and initial process is included below. Galveston County reserves the right to change these dates and will notify Bidders of any changes:

| | |
|--|--|
| Advertise BID (first date of publication) | Friday, December 13, 2019 |
| Advertise BID (second date of publication) | Friday, December 20, 2019 |
| Pre-Bid Conference | Tuesday, January 21, 2020 at 10:00 a.m. |
| Deadline for Questions & Inquiries | Tuesday, January 28, 2020 by 5:00 p.m. |
| Bids due from public/Bid Opening | Thursday, February 13, 2020 at 2:00 p.m. |

**SPECIAL PROVISIONS
JERRY ESMOND JUVENILE JUSTICE CENTER ROOF REPLACEMENT
GALVESTON COUNTY**

H. PRE-BID CONFERENCE

A non-mandatory pre-bid conference will be held on **Tuesday, January 21, 2020, at 10:00 a.m.** at the Jerry J. Esmond Juvenile Justice Department, 6101 Attwater Ave, Texas City, TX 77590

I. SUBMISSION INSTRUCTIONS

One (1) unbound original and three (3) copies of the requested bid submittals must be submitted no later than **2:00 P.M. CST, on Thursday, February 13, 2020 to:**

**Rufus G. Crowder, CPPO CPPB
Purchasing Agent
County of Galveston
722 Moody Avenue (21st Street), Fifth (5th) Floor
Galveston, TX 77550**

The time stamp clock located in the Purchasing Agent's office shall serve as the official time keeping piece for this solicitation process. Any Bids received after **2:00 P.M. CST** on the specified date will be returned unopened.

Specifications can be obtained at the office of the Galveston County Purchasing Agent, located in the Galveston County Courthouse, 722 Moody, (21st Street), Floor 5, Purchasing, Galveston, Texas 77550, or by visiting the Galveston County website @ <http://www.galvestoncountytexas.gov/pu/Pages/BidListing.aspx>.

J. PERSONNEL TO CONTACT

Bidders desiring an explanation or interpretation relative to this solicitation must request it in writing. Oral explanations or instructions will not be binding. Any information given to a Bidder, which in the opinion of the County affects all responders or would be prejudicial to other Bidders if not communicated, shall be furnished to all Bidders as an addendum to the solicitation. Bidders **must** direct all inquiries to the following:

**Rufus G. Crowder, CPPO CPPB
Purchasing Agent
722 21st Street (Moody)
Galveston, Texas 77550
e-mail: purchasing.bids@co.galveston.tx.us**

Bidders must e-mail their requests (with the subject line "**Jerry Esmond Juvenile Justice Center Roof Replacement – Bid# B201022– Questions**") for additional information and/or clarification to the address listed above. The request must include the Bidder's name and the BID number and title. ***Any request for additional information or clarification must be received in writing no later than seven (7) calendar days prior to the Bid due date.*** Late requests or those not delivered to the proper address may not receive a reply. Bidders shall not attempt to contact the County by any other means. The Purchasing Agent's Office shall post the answers to the County website from the procurement web page and via addendum.

The County will issue responses to inquiries and any other corrections or amendments, it deems necessary, in the form of a written addendum, issued prior to the Bid Submission Date. The County, at its sole discretion, may not issue a response to a RFI submittal. Bidders should not rely on any oral or written representations, statements, or explanations, other than those made in this BID or in any written addendum to this BID. Where there appears to be conflict between the BID and any issued addenda, the

SPECIAL PROVISIONS
JERRY ESMOND JUVENILE JUSTICE CENTER ROOF REPLACEMENT
GALVESTON COUNTY

last addendum issued will prevail. Addenda will be posted and made available on the County's procurement web page. It is the Bidder's sole responsibility to ensure receipt of all addenda prior to submitting its Bid. All Bidders should check the County's procurement web page for all addenda prior to submitting a response. The County's procurement web page is located at www.galvestoncountytexas.gov/pu/Pages/default.aspx, and current solicitations are at www.galvestoncountytexas.gov/pu/Pages/OpenSolicitations.aspx.

The Bidder must acknowledge the receipt of all addenda on the forms provided. In the event a Bidder fails to acknowledge receipt of such addenda, the County may, at its sole discretion, determine that such failure to acknowledge any or all addenda does not materially affect the Bid and waive the acknowledgement of one or more addenda.

Bidders who submit inquiries *after* the deadline date for receipt of questions indicated on the Procurement Timeline, risk that its response in the procurement will not be responsive or competitive because the County is not able to respond before the Bid receipt date or in sufficient time for the Bidder to prepare a responsive or competitive submittal.

All questions and responses as posted on the County website pertaining to this BID are considered an addendum to, and part of, this BID. Each Bidder shall be responsible to monitor the County website for new or revised BID information. The County shall not be bound by any verbal information nor shall it be bound by any written information that is not either contained within the BID or formally issued as an addendum by the Purchasing Agent's Office.

K. PROGRAM ADMINISTRATION & CONTRACT MANAGEMENT

The Program Administrator/Contract Manager that will manage the work to be performed under the resultant contract for the purpose of this bid is:

William Riordan
Galveston County Facilities Director
722 Moody, (21st St.), 6th Floor
Galveston, TX 77550
(409) 765-2643
Email: william.riordan@co.galveston.tx.us

L. TYPE OF CONTRACT

It is the intent of this solicitation to enter into a contract that meets federal guidelines. It is imperative that all responders seeking a contract under this solicitation effort must familiarize and adhere to the procurement standards as referenced in 2 C.F.R. Part 200, Sections 200.317-200.326, and Appendix II, 2 C.F.R. Part 200. Sections 200.317-200.326 and Appendix II are attached hereto as **Attachment A**.

The resultant contract consists of the following documents: Invitation to Bid, General Provisions, Special Provisions, General Terms and Conditions (including specifications, drawings, and addenda), Bidder's Bid, Bid Sheets, contract award, and any other documents referenced herein or attached hereto for the work. Collectively these documents may also be referred to as the Plans and Specifications.

In an effort to satisfy cost reasonableness responsibilities at the time of any extension period, the County of Galveston reserves the right to obtain additional quotes and current pricing information from the successful contractor and other contractors to perform the work as stated per the specification listed herein and in the resultant. The solicited results may be used by the County to determine if the contract extensions will be considered or other service options be utilized.

**SPECIAL PROVISIONS
JERRY ESMOND JUVENILE JUSTICE CENTER ROOF REPLACEMENT
GALVESTON COUNTY**

M. COLLATERAL CONTRACT

The County reserves the right to provide by separate contract or otherwise, in such manner as not to delay its programs or damage said Contractor, all labor and material essential to the completion of the work that is not included in this contract.

Award prices include all royalties and costs arising from patents, trademarks, and copyrights in any way involved in the work. Whenever the Awardee is required or desires to use any design, device, material or process covered by letters of patent or copyright, the Awardee shall indemnify and save harmless the County, its officers, agents and employees from any and all claims for infringement by reason of the use of any such patented design, tool, material, equipment, or process, to be performed under the contract, and shall indemnify the County its officers, agents, and employees for any costs, expenses and damages which may be incurred by reason of any infringement at any time during the prosecution or after the completion of the work.

N. LABOR

Contractor is encouraged to use local labor, but not at the expense of poor workmanship and higher cost. Contractor will not discriminate against any employee or applicant for employment because of race, religion, color, sex or national origin. Contractor agrees to post in a conspicuous place a notice setting forth provisions of this non-discrimination clause.

O. INSURANCE

Bidder must submit, with its response, a current certificate of insurance evidencing coverage in the amounts specified below or greater. In lieu of submitting a certificate of insurance, Respondents may submit a notarized statement from an insurance company authorized to conduct business in the State of Texas guaranteeing that Respondent has such insurance. Provided however, that successful Respondent(s) shall be required to provide a current certificate of insurance to the Galveston County Purchasing Agent's Office before Respondent commences any work hereunder. **Insurance shall be placed with insurers having an A.M. Best's rating of no less than A.** Such insurance must be issued by a casualty company authorized to do business in the State of Texas, and in standard form approved by the Board of Insurance Commissioners of the State of Texas, with coverage provisions insuring the public from loss or damage that may arise to any person or property by reason of services rendered by Contractor.

Galveston County shall be listed as an additional insured on each policy and all certificates of insurance and Contractor shall provide Galveston County with no less than thirty (30) calendar days prior notice of any changes to the policy during the contractual period.

Certificates of Insurance, fully executed by a licensed representative of the insurance company written or countersigned by an authorized Texas state agency, shall be filed with the County Purchasing Agent within ten (10) calendar days of the execution of this Agreement as written proof of such insurance and further provided that Contractor shall not commence work under this Agreement until Contractor has obtained all insurance required herein, provided written proof as required herein, and received written notice to proceed issued from the County Purchasing Agent. **Failure to provide such evidence of insurance within the ten (10) calendar day period shall constitute an event of default.**

Workers' Compensation Insurance. Respondent shall carry in full force Workers' Compensation Insurance Policy(ies), if there is more than one employee, for all its employees, including but not limited to full time, part time, and emergency employees employed by the Contractor.

Commercial General Liability. Respondent shall carry in full force commercial general liability insurance with a limit of not less than \$1,000,000 each occurrence and \$2,000,000 in the aggregate. The Policy shall, minimally, cover liability for bodily injury, personal injury, and property damage.

SPECIAL PROVISIONS
JERRY ESMOND JUVENILE JUSTICE CENTER ROOF REPLACEMENT
GALVESTON COUNTY

Business Automobile Liability. Respondent shall carry in full force business automobile liability coverage with a combined bodily injury/property damage limit of not less than \$1,000,000 each accident. The policy shall cover liability arising from the operation of licensed vehicles by policyholder.

Professional Liability. Respondent shall carry in full force professional liability insurance with limits of not less than \$1,000,000.00.

Subrogation Waiver. Contractor and Contractor's insurance carrier shall waive any and all rights to subrogation against Galveston County in regard to any suit or claim arising out of personal injury or property damage resulting from Contractor's performance under this Agreement.

P. EXCEPTIONS

Any exceptions to Bid conditions should be listed on a separated sheet of paper, attached to Bid submittals and submitted with Bid at the specified date and time of Bid opening.

ATTACHMENT A
JERRYJ. ESMOND JUVENILE JUSTICE CENTER ROOF REPLACEMENT
GALVESTON COUNTY, TEXAS

PROCUREMENT STANDARDS

2 C.F.R. §§ 200.317 – 200.326 &
2 C.F.R. PART 200, APPENDIX II

TABLE OF CONTENTS

| | |
|--|-------|
| 2 C.F.R. § 200.317. Procurements by states | 2 |
| 2 C.F.R. § 200.318. General procurement standards | 2-3 |
| 2 C.F.R. § 200.319. Competition | 4-5 |
| 2 C.F.R. § 200.320. Methods of procurement to be followed..... | 5-7 |
| 2 C.F.R. § 200.321. Contracting with small and minority businesses, women's business enterprises, and labor surplus area firms. | 7 |
| 2 C.F.R. § 200.322. Procurement of recovered materials | 8 |
| 2 C.F.R. § 200.323. Contract cost and price | 8 |
| 2 C.F.R. § 200.324. Federal awarding agency or pass-through entity review | 8-9 |
| 2 C.F.R. § 200.325. Bonding requirements | 9-10 |
| 2 C.F.R. § 200.326. Contract provisions..... | 10 |
| 2 C.F.R. Part, 200, Appendix II | 11-12 |

ATTACHMENT A
JERRYJ. ESMOND JUVENILE JUSTICE CENTER ROOF REPLACEMENT
GALVESTON COUNTY, TEXAS

PROCUREMENT STANDARDS

2 C.F.R. §§ 200.317 – 200.326 &
2 C.F.R. PART 200, APPENDIX II

2 C.F.R. § 200.317. Procurements by states.

When procuring property and services under a Federal award, a state must follow the same policies and procedures it uses for procurements from its non-Federal funds. The state will comply with §200.322 Procurement of recovered materials and ensure that every purchase order or other contract includes any clauses required by section §200.326 Contract provisions. All other non-Federal entities, including sub-recipients of a state, will follow §§ 200.318 General procurement standards through 200.326 Contract provisions.

69 FR 26280, May 11, 2004; 78 FR 78608, Dec. 26, 2013

2 C.F.R. § 200.318. General procurement standards.

(a) The non-Federal entity must use its own documented procurement procedures which reflect applicable State, local and tribal laws and regulations, provided that the procurements conform to applicable Federal law and the standards identified in this part.

(b) Non-Federal entities must maintain oversight to ensure that contractors perform in accordance with the terms, conditions, and specifications of their contracts or purchase orders.

(c)

(1) The non-Federal entity must maintain written standards of conduct covering conflicts of interest and governing the actions of its employees engaged in the selection, award and administration of contracts. No employee, officer, or agent may participate in the selection, award, or administration of a contract supported by a Federal award if he or she has a real or apparent conflict of interest. Such a conflict of interest would arise when the employee, officer, or agent, any member of his or her immediate family, his or her partner, or an organization which employs or is about to employ any of the parties indicated herein, has a financial or other interest in or a tangible personal benefit from a firm considered for a contract. The officers, employees, and agents of the non-Federal entity may neither solicit nor accept gratuities, favors, or anything of monetary value from contractors or parties to subcontracts. However, non-Federal entities may set standards for situations in which the financial interest is not substantial or the gift is an unsolicited item of nominal value. The standards of conduct must provide for disciplinary actions to be applied for violations of such standards by officers, employees, or agents of the non-Federal entity.

(2) If the non-Federal entity has a parent, affiliate, or subsidiary organization that is not a state, local government, or Indian tribe, the non-Federal entity must also maintain written standards of conduct covering organizational conflicts of interest. Organizational conflicts of interest means that because of

ATTACHMENT A
JERRYJ. ESMOND JUVENILE JUSTICE CENTER ROOF REPLACEMENT
GALVESTON COUNTY, TEXAS

relationships with a parent company, affiliate, or subsidiary organization, the non-Federal entity is unable or appears to be unable to be impartial in conducting a procurement action involving a related organization.

- (d) The non-Federal entity's procedures must avoid acquisition of unnecessary or duplicative items. Consideration should be given to consolidating or breaking out procurements to obtain a more economical purchase. Where appropriate, an analysis will be made of lease versus purchase alternatives, and any other appropriate analysis to determine the most economical approach.
- (e) To foster greater economy and efficiency, and in accordance with efforts to promote cost-effective use of shared services across the Federal Government, the non-Federal entity is encouraged to enter into state and local intergovernmental agreements or inter-entity agreements where appropriate for procurement or use of common or shared goods and services.
- (f) The non-Federal entity is encouraged to use Federal excess and surplus property in lieu of purchasing new equipment and property whenever such use is feasible and reduces project costs.
- (g) The non-Federal entity is encouraged to use value engineering clauses in contracts for construction projects of sufficient size to offer reasonable opportunities for cost reductions. Value engineering is a systematic and creative analysis of each contract item or task to ensure that its essential function is provided at the overall lower cost.
- (h) The non-Federal entity must award contracts only to responsible contractors possessing the ability to perform successfully under the terms and conditions of a proposed procurement. Consideration will be given to such matters as contractor integrity, compliance with public policy, record of past performance, and financial and technical resources. See also § 200.213 Suspension and debarment.
- (i) The non-Federal entity must maintain records sufficient to detail the history of procurement. These records will include, but are not necessarily limited to the following: rationale for the method of procurement, selection of contract type, contractor selection or rejection, and the basis for the contract price.
- (j)
- (1) The non-Federal entity may use a time and materials type contract only after a determination that no other contract is suitable and if the contract includes a ceiling price that the contractor exceeds at its own risk. Time and materials type contract means a contract whose cost to a non-Federal entity is the sum of:
- (i) The actual cost of materials; and
 - (ii) Direct labor hours charged at fixed hourly rates that reflect wages, general and administrative expenses, and profit.
- (2) Since this formula generates an open-ended contract price, a time-and-materials contract provides no positive profit incentive to the contractor for cost control or labor efficiency. Therefore, each contract must set a ceiling price that the contractor exceeds at its own risk. Further, the non-Federal entity awarding such a contract must assert a high degree of oversight in order to obtain reasonable assurance that the contractor is using efficient methods and effective cost controls.

ATTACHMENT A
JERRYJ. ESMOND JUVENILE JUSTICE CENTER ROOF REPLACEMENT
GALVESTON COUNTY, TEXAS

(k) The non-Federal entity alone must be responsible, in accordance with good administrative practice and sound business judgment, for the settlement of all contractual and administrative issues arising out of procurements. These issues include, but are not limited to, source evaluation, protests, disputes, and claims. These standards do not relieve the non-Federal entity of any contractual responsibilities under its contracts. The Federal awarding agency will not substitute its judgment for that of the non-Federal entity unless the matter is primarily a Federal concern. Violations of law will be referred to the local, state, or Federal authority having proper jurisdiction.

78 FR 78608, Dec. 26, 2013, as amended at 79 FR 75885, Dec. 19, 2014; 80 FR 43309, July 22, 2015; 80 FR 45395, July 30, 2015

2 C.F.R. § 200.319. Competition.

(a) All procurement transactions must be conducted in a manner providing full and open competition consistent with the standards of this section. In order to ensure objective contractor performance and eliminate unfair competitive advantage, contractors that develop or draft specifications, requirements, statements of work, or invitations for bids or requests for proposals must be excluded from competing for such procurements. Some of the situations considered to be restrictive of competition include but are not limited to:

- (1) Placing unreasonable requirements on firms in order for them to qualify to do business;
- (2) Requiring unnecessary experience and excessive bonding;
- (3) Noncompetitive pricing practices between firms or between affiliated companies;
- (4) Noncompetitive contracts to consultants that are on retainer contracts;
- (5) Organizational conflicts of interest;
- (6) Specifying only a “brand name” product instead of allowing “an equal” product to be offered and describing the performance or other relevant requirements of the procurement; and
- (7) Any arbitrary action in the procurement process.

(b) The non-Federal entity must conduct procurements in a manner that prohibits the use of statutorily or administratively imposed state, local, or tribal geographical preferences in the evaluation of bids or proposals, except in those cases where applicable Federal statutes expressly mandate or encourage geographic preference. Nothing in this section preempts state licensing laws. When contracting for architectural and engineering (A/E) services, geographic location may be a selection criterion provided its application leaves an appropriate number of qualified firms, given the nature and size of the project, to compete for the contract.

(c) The non-Federal entity must have written procedures for procurement transactions. These procedures must ensure that all solicitations:

- (1) Incorporate a clear and accurate description of the technical requirements for the material, product, or service to be procured. Such description must not, in competitive procurements, contain features which unduly

ATTACHMENT A
JERRYJ. ESMOND JUVENILE JUSTICE CENTER ROOF REPLACEMENT
GALVESTON COUNTY, TEXAS

restrict competition. The description may include a statement of the qualitative nature of the material, product or service to be procured and, when necessary, must set forth those minimum essential characteristics and standards to which it must conform if it is to satisfy its intended use. Detailed product specifications should be avoided if at all possible. When it is impractical or uneconomical to make a clear and accurate description of the technical requirements, a "brand name or equivalent" description may be used as a means to define the performance or other salient requirements of procurement. The specific features of the named brand which must be met by offers must be clearly stated; and

(2) Identify all requirements which the offerors must fulfill and all other factors to be used in evaluating bids or proposals.

(d) The non-Federal entity must ensure that all prequalified lists of persons, firms, or products which are used in acquiring goods and services are current and include enough qualified sources to ensure maximum open and free competition. Also, the non-Federal entity must not preclude potential bidders from qualifying during the solicitation period.

78 FR 78608, Dec. 26, 2013, as amended at 79 FR 75885, Dec. 19, 2014

2 C.F.R. § 200.320. Methods of procurement to be followed.

The non-Federal entity must use one of the following methods of procurement.

(a) Procurement by micro-purchases. Procurement by micro-purchase is the acquisition of supplies or services, the aggregate dollar amount of which does not exceed the micro-purchase threshold (§200.67 Micro-purchase). To the extent practicable, the non-Federal entity must distribute micro-purchases equitably among qualified suppliers. Micro-purchases may be awarded without soliciting competitive quotations if the non-Federal entity considers the price to be reasonable.

(b) Procurement by small purchase procedures. Small purchase procedures are those relatively simple and informal procurement methods for securing services, supplies, or other property that do not cost more than the Simplified Acquisition Threshold. If small purchase procedures are used, price or rate quotations must be obtained from an adequate number of qualified sources.

(c) Procurement by sealed bids (formal advertising). Bids are publicly solicited and a firm fixed price contract (lump sum or unit price) is awarded to the responsible bidder whose bid, conforming with all the material terms and conditions of the invitation for bids, is the lowest in price. The sealed bid method is the preferred method for procuring construction, if the conditions in paragraph (c)(1) of this section apply.

(1) In order for sealed bidding to be feasible, the following conditions should be present:

(i) A complete, adequate, and realistic specification or purchase description is available;

(ii) Two or more responsible bidders are willing and able to compete effectively for the business; and

(iii) The procurement lends itself to a firm fixed price contract and the selection of the successful bidder can be made principally on the basis of price.

ATTACHMENT A
JERRYJ. ESMOND JUVENILE JUSTICE CENTER ROOF REPLACEMENT
GALVESTON COUNTY, TEXAS

(2) If sealed bids are used, the following requirements apply:

(i) Bids must be solicited from an adequate number of known suppliers, providing them sufficient response time prior to the date set for opening the bids, for local, and tribal governments, the invitation for bids must be publicly advertised;

(ii) The invitation for bids, which will include any specifications and pertinent attachments, must define the items or services in order for the bidder to properly respond;

(iii) All bids will be opened at the time and place prescribed in the invitation for bids, and for local and tribal governments, the bids must be opened publicly;

(iv) A firm fixed price contract award will be made in writing to the lowest responsive and responsible bidder. Where specified in bidding documents, factors such as discounts, transportation cost, and life cycle costs must be considered in determining which bid is lowest. Payment discounts will only be used to determine the low bid when prior experience indicates that such discounts are usually taken advantage of; and

(v) Any or all bids may be rejected if there is a sound documented reason.

(d) Procurement by competitive proposals. The technique of competitive proposals is normally conducted with more than one source submitting an offer, and either a fixed price or cost-reimbursement type contract is awarded. It is generally used when conditions are not appropriate for the use of sealed bids. If this method is used, the following requirements apply:

(1) Requests for proposals must be publicized and identify all evaluation factors and their relative importance. Any response to publicized requests for proposals must be considered to the maximum extent practical;

(2) Proposals must be solicited from an adequate number of qualified sources;

(3) The non-Federal entity must have a written method for conducting technical evaluations of the proposals received and for selecting recipients;

(4) Contracts must be awarded to the responsible firm whose proposal is most advantageous to the program, with price and other factors considered; and

(5) The non-Federal entity may use competitive proposal procedures for qualifications-based procurement of architectural/engineering (A/E) professional services whereby competitors' qualifications are evaluated and the most qualified competitor is selected, subject to negotiation of fair and reasonable compensation. The method, where price is not used as a selection factor, can only be used in procurement of A/E professional services. It cannot be used to purchase other types of services though A/E firms are a potential source to perform the proposed effort.

(e) [Reserved]

ATTACHMENT A
JERRYJ. ESMOND JUVENILE JUSTICE CENTER ROOF REPLACEMENT
GALVESTON COUNTY, TEXAS

(f) Procurement by noncompetitive proposals. Procurement by noncompetitive proposals is procurement through solicitation of a proposal from only one source and may be used only when one or more of the following circumstances apply:

- (1) The item is available only from a single source;
- (2) The public exigency or emergency for the requirement will not permit a delay resulting from competitive solicitation;
- (3) The Federal awarding agency or pass-through entity expressly authorizes noncompetitive proposals in response to a written request from the non-Federal entity; or
- (4) After solicitation of a number of sources, competition is determined inadequate.

78 FR 78608, Dec. 26, 2013, as amended at 79 FR 75885, Dec. 19, 2014; 80 FR 54409, Sept. 10, 2015

2 C.F.R. § 200.321. Contracting with small and minority businesses, women's business enterprises, and labor surplus area firms.

(a) The non-Federal entity must take all necessary affirmative steps to assure that minority businesses, women's business enterprises, and labor surplus area firms are used when possible.

(b) Affirmative steps must include:

- (1) Placing qualified small and minority businesses and women's business enterprises on solicitation lists;
- (2) Assuring that small and minority businesses, and women's business enterprises are solicited whenever they are potential sources;
- (3) Dividing total requirements, when economically feasible, into smaller tasks or quantities to permit maximum participation by small and minority businesses, and women's business enterprises;
- (4) Establishing delivery schedules, where the requirement permits, which encourage participation by small and minority businesses, and women's business enterprises;
- (5) Using the services and assistance, as appropriate, of such organizations as the Small Business Administration and the Minority Business Development Agency of the Department of Commerce; and
- (6) Requiring the prime contractor, if subcontracts are to be let, to take the affirmative steps listed in paragraphs (1) through (5) of this section.

69 FR 26280, May 11, 2004; 78 FR 78608, Dec. 26, 2013, unless otherwise noted

ATTACHMENT A
JERRYJ. ESMOND JUVENILE JUSTICE CENTER ROOF REPLACEMENT
GALVESTON COUNTY, TEXAS

2 C.F.R. § 200.322. Procurement of recovered materials.

A non-Federal entity that is a state agency or agency of a political subdivision of a state and its contractors must comply with section 6002 of the Solid Waste Disposal Act, as amended by the Resource Conservation and Recovery Act. The requirements of Section 6002 include procuring only items designated in guidelines of the Environmental Protection Agency (EPA) at 40 CFR part 247 that contain the highest percentage of recovered materials practicable, consistent with maintaining a satisfactory level of competition, where the purchase price of the item exceeds \$10,000 or the value of the quantity acquired during the preceding fiscal year exceeded \$10,000; procuring solid waste management services in a manner that maximizes energy and resource recovery; and establishing an affirmative procurement program for procurement of recovered materials identified in the EPA guidelines.

78 FR 78608, Dec. 26, 2013, as amended at 79 FR 75885, Dec. 19, 2014

2 C.F.R. § 200.323. Contract cost and price.

(a) The non-Federal entity must perform a cost or price analysis in connection with every procurement action in excess of the Simplified Acquisition Threshold including contract modifications. The method and degree of analysis is dependent on the facts surrounding the particular procurement situation, but as a starting point, the non-Federal entity must make independent estimates before receiving bids or proposals.

(b) The non-Federal entity must negotiate profit as a separate element of the price for each contract in which there is no price competition and in all cases where cost analysis is performed. To establish a fair and reasonable profit, consideration must be given to the complexity of the work to be performed, the risk borne by the contractor, the contractor's investment, the amount of subcontracting, the quality of its record of past performance, and industry profit rates in the surrounding geographical area for similar work.

(c) Costs or prices based on estimated costs for contracts under the Federal award are allowable only to the extent that costs incurred or cost estimates included in negotiated prices would be allowable for the non-Federal entity under Subpart E—Cost Principles of this part. The non-Federal entity may reference its own cost principles that comply with the Federal cost principles.

(d) The cost plus a percentage of cost and percentage of construction cost methods of contracting must not be used.

69 FR 26280, May 11, 2004; 78 FR 78608, Dec. 26, 2013, unless otherwise noted

2 C.F.R. § 200.324. Federal awarding agency or pass-through entity review.

(a) The non-Federal entity must make available, upon request of the Federal awarding agency or pass-through entity, technical specifications on proposed procurements where the Federal awarding agency or pass-through entity believes such review is needed to ensure that the item or service specified is the one being proposed for acquisition. This review generally will take place prior to the time the specification is incorporated into a solicitation document. However, if the non-Federal entity desires to have the review accomplished after a solicitation has been developed, the Federal awarding agency or pass-through entity may still review the specifications, with such review usually limited to the technical aspects of the proposed purchase.

ATTACHMENT A
JERRYJ. ESMOND JUVENILE JUSTICE CENTER ROOF REPLACEMENT
GALVESTON COUNTY, TEXAS

(b) The non-Federal entity must make available upon request, for the Federal awarding agency or pass-through entity pre-procurement review, procurement documents, such as requests for proposals or invitations for bids, or independent cost estimates, when:

- (1) The non-Federal entity's procurement procedures or operation fails to comply with the procurement standards in this part;
- (2) The procurement is expected to exceed the Simplified Acquisition Threshold and is to be awarded without competition or only one bid or offer is received in response to a solicitation;
- (3) The procurement, which is expected to exceed the Simplified Acquisition Threshold, specifies a "brand name" product;
- (4) The proposed contract is more than the Simplified Acquisition Threshold and is to be awarded to other than the apparent low bidder under a sealed bid procurement; or
- (5) A proposed contract modification changes the scope of a contract or increases the contract amount by more than the Simplified Acquisition Threshold.

(c) The non-Federal entity is exempt from the pre-procurement review in paragraph (b) of this section if the Federal awarding agency or pass-through entity determines that its procurement systems comply with the standards of this part.

- (1) The non-Federal entity may request that its procurement system be reviewed by the Federal awarding agency or pass-through entity to determine whether its system meets these standards in order for its system to be certified. Generally, these reviews must occur where there is continuous high-dollar funding, and third party contracts are awarded on a regular basis;
- (2) The non-Federal entity may self-certify its procurement system. Such self-certification must not limit the Federal awarding agency's right to survey the system. Under a self-certification procedure, the Federal awarding agency may rely on written assurances from the non-Federal entity that it is complying with these standards. The non-Federal entity must cite specific policies, procedures, regulations, or standards as being in compliance with these requirements and have its system available for review.

69 FR 26280, May 11, 2004; 78 FR 78608, Dec. 26, 2013, unless otherwise noted

2 C.F.R. § 200.325. Bonding requirements.

For construction or facility improvement contracts or subcontracts exceeding the Simplified Acquisition Threshold, the Federal awarding agency or pass-through entity may accept the bonding policy and requirements of the non-Federal entity provided that the Federal awarding agency or pass-through entity has made a determination that the Federal interest is adequately protected. If such a determination has not been made, the minimum requirements must be as follows:

- (a) A bid guarantee from each bidder equivalent to five percent of the bid price. The "bid guarantee" must consist of a firm commitment such as a bid bond, certified check, or other negotiable instrument accompanying a bid as assurance that the bidder will, upon acceptance of the bid, execute such contractual documents as may be required within the time specified.

ATTACHMENT A
JERRYJ. ESMOND JUVENILE JUSTICE CENTER ROOF REPLACEMENT
GALVESTON COUNTY, TEXAS

(b) A performance bond on the part of the contractor for 100 percent of the contract price. A “performance bond” is one executed in connection with a contract to secure fulfillment of all the contractor's obligations under such contract.

(c) A payment bond on the part of the contractor for 100 percent of the contract price. A “payment bond” is one executed in connection with a contract to assure payment as required by law of all persons supplying labor and material in the execution of the work provided for in the contract.

69 FR 26280, May 11, 2004; 78FR 78608, Dec. 26, 2013, unless otherwise noted

2 C.F.R. § 200.326. Contract provisions.

The non-Federal entity's contracts must contain the applicable provisions described in Appendix II to Part 200—Contract Provisions for non-Federal Entity Contracts Under Federal Awards.

69 FR 26280, May 11, 2004; 78 FR 78608, Dec. 26, 2013, unless otherwise note

ATTACHMENT A
JERRYJ. ESMOND JUVENILE JUSTICE CENTER ROOF REPLACEMENT
GALVESTON COUNTY, TEXAS

2 C.F.R. Part, 200, Appendix II

In addition to other provisions required by the Federal agency or non-Federal entity, all contracts made by the non-Federal entity under the Federal award must contain provisions covering the following, as applicable.

(A) Contracts for more than the simplified acquisition threshold currently set at \$150,000, which is the inflation adjusted amount determined by the Civilian Agency Acquisition Council and the Defense Acquisition Regulations Council (Councils) as authorized by 41 U.S.C. 1908, must address administrative, contractual, or legal remedies in instances where contractors violate or breach contract terms, and provide for such sanctions and penalties as appropriate.

(B) All contracts in excess of \$10,000 must address termination for cause and for convenience by the non-Federal entity including the manner by which it will be effected and the basis for settlement.

(C) Equal Employment Opportunity. Except as otherwise provided under 41 CFR Part 60, all contracts that meet the definition of "federally assisted construction contract" in 41 CFR Part 60-1.3 must include the equal opportunity clause provided under 41 CFR 60-1.4(b), in accordance with Executive Order 11246, "Equal Employment Opportunity" (30 FR 12319, 12935, 3 CFR Part, 1964-1965 Comp., p. 339), as amended by Executive Order 11375, "Amending Executive Order 11246 Relating to Equal Employment Opportunity," and implementing regulations at 41 CFR part 60, "Office of Federal Contract Compliance Programs, Equal Employment Opportunity, Department of Labor."

(D) Davis-Bacon Act, as amended (40 U.S.C. 3141-3148). When required by Federal program legislation, all prime construction contracts in excess of \$2,000 awarded by non-Federal entities must include a provision for compliance with the Davis-Bacon Act (40 U.S.C. 3141-3144, and 3146-3148) as supplemented by Department of Labor regulations (29 CFR Part 5, "Labor Standards Provisions Applicable to Contracts Covering Federally Financed and Assisted Construction"). In accordance with the statute, contractors must be required to pay wages to laborers and mechanics at a rate not less than the prevailing wages specified in a wage determination made by the Secretary of Labor. In addition, contractors must be required to pay wages not less than once a week. The non-Federal entity must place a copy of the current prevailing wage determination issued by the Department of Labor in each solicitation. The decision to award a contract or subcontract must be conditioned upon the acceptance of the wage determination. The non-Federal entity must report all suspected or reported violations to the Federal awarding agency. The contracts must also include a provision for compliance with the Copeland "Anti-Kickback" Act (40 U.S.C. 3145), as supplemented by Department of Labor regulations (29 CFR Part 3, "Contractors and Subcontractors on Public Building or Public Work Financed in Whole or in Part by Loans or Grants from the United States"). The Act provides that each contractor or subrecipient must be prohibited from inducing, by any means, any person employed in the construction, completion, or repair of public work, to give up any part of the compensation to which he or she is otherwise entitled. The non-Federal entity must report all suspected or reported violations to the Federal awarding agency.

(E) Contract Work Hours and Safety Standards Act (40 U.S.C. 3701-3708). Where applicable, all contracts awarded by the non-Federal entity in excess of \$100,000 that involve the employment of mechanics or laborers must include a provision for compliance with 40 U.S.C. 3702 and 3704, as supplemented by Department of Labor regulations (29 CFR Part 5). Under 40 U.S.C. 3702 of the Act, each contractor must be required to compute the wages of every mechanic and laborer on the basis of a standard work week of 40 hours. Work in excess of the standard work week is permissible provided that the worker is compensated at a rate of not less than one and a half times the basic rate of pay for all hours worked in excess of 40 hours in the work week. The requirements of 40 U.S.C. 3704 are applicable to construction work and provide that no laborer or mechanic must be required to work in surroundings or under working conditions which are unsanitary, hazardous or

ATTACHMENT A
JERRYJ. ESMOND JUVENILE JUSTICE CENTER ROOF REPLACEMENT
GALVESTON COUNTY, TEXAS

dangerous. These requirements do not apply to the purchases of supplies or materials or articles ordinarily available on the open market, or contracts for transportation or transmission of intelligence.

(F) Rights to Inventions Made Under a Contract or Agreement. If the Federal award meets the definition of “funding agreement” under 37 CFR §401.2 (a) and the recipient or subrecipient wishes to enter into a contract with a small business firm or nonprofit organization regarding the substitution of parties, assignment or performance of experimental, developmental, or research work under that “funding agreement,” the recipient or subrecipient must comply with the requirements of 37 CFR Part 401, “Rights to Inventions Made by Nonprofit Organizations and Small Business Firms Under Government Grants, Contracts and Cooperative Agreements,” and any implementing regulations issued by the awarding agency.

(G) Clean Air Act (42 U.S.C. 7401-7671q.) and the Federal Water Pollution Control Act (33 U.S.C. 1251-1387), as amended—Contracts and subgrants of amounts in excess of \$150,000 must contain a provision that requires the non-Federal award to agree to comply with all applicable standards, orders or regulations issued pursuant to the Clean Air Act (42 U.S.C. 7401-7671q) and the Federal Water Pollution Control Act as amended (33 U.S.C. 1251-1387). Violations must be reported to the Federal awarding agency and the Regional Office of the Environmental Protection Agency (EPA).

(H) Debarment and Suspension (Executive Orders 12549 and 12689)—A contract award (see 2 CFR 180.220) must not be made to parties listed on the governmentwide exclusions in the System for Award Management (SAM), in accordance with the OMB guidelines at 2 CFR 180 that implement Executive Orders 12549 (3 CFR part 1986 Comp., p. 189) and 12689 (3 CFR part 1989 Comp., p. 235), “Debarment and Suspension.” SAM Exclusions contains the names of parties debarred, suspended, or otherwise excluded by agencies, as well as parties declared ineligible under statutory or regulatory authority other than Executive Order 12549.

(I) Byrd Anti-Lobbying Amendment (31 U.S.C. 1352)—Contractors that apply or bid for an award exceeding \$100,000 must file the required certification. Each tier certifies to the tier above that it will not and has not used Federal appropriated funds to pay any person or organization for influencing or attempting to influence an officer or employee of any agency, a member of Congress, officer or employee of Congress, or an employee of a member of Congress in connection with obtaining any Federal contract, grant or any other award covered by 31 U.S.C. 1352. Each tier must also disclose any lobbying with non-Federal funds that takes place in connection with obtaining any Federal award. Such disclosures are forwarded from tier to tier up to the non-Federal award.

(J) See §200.322 Procurement of recovered materials.

78 FR 78608, Dec. 26, 2013, as amended at 79 FR 75888, Dec. 19, 2014

CERTIFICATION REGARDING LOBBYING
(31 U.S.C.A. § 1352)
This Certification must be completed, signed, dated and
returned to the Galveston County Purchasing Agent

Procurement Number and Description: _____
_____ BID #B201022, Jerry J. Esmond Juvenile Justice Center Roof Replacement _____

Proposer **CERTIFIES**, to the best of its knowledge and belief, that:

1. No Federal appropriated funds have been paid or will be paid, by or on behalf of the proposer, to any person for influencing or attempting to influence an officer or employee of an agency, a Member of Congress, an officer or employee of Congress, or an employee of a Member of Congress in connection with the awarding of any Federal contract, the making of any Federal grant, the making of any Federal loan, the entering into of any cooperative agreement, and the extension, continuation, renewal, amendment, or modification of any Federal contract, grant, loan, or cooperative agreement.
2. If any funds other than Federal appropriated funds have been paid or will be paid to any person for influencing or attempting to influence an officer or employee of any agency, a Member of Congress, an officer or employee of Congress, or an employee of a Member of Congress in connection with this Federal contract, grant, loan, or cooperative agreement, the proposer shall complete and submit **Standard Form LLL**, "Disclosure Form to Report Lobbying", in accordance with its instructions.
3. Proposer shall require that the language of this certification be included in the award documents for all subawards at all tiers (including subcontracts, subgrants, and contracts under grants, loans, and cooperative agreements) and that all subrecipients shall certify and disclose accordingly.

This certification is a material representation of fact upon which reliance was placed when this transaction was made or entered into. Submission of this certification is a prerequisite for making or entering into this transaction imposed by Section 1352, Title 31, U.S. Code. Any person who fails to file the required certification shall be subject to a civil penalty of not less than \$10,000 and not more than \$100,000 for each such failure.

Name of Organization/Corporation: _____

Address: _____

City: _____ State: _____ Zip Code: _____

Signature of Authorized Signatory for Proposer: _____ Date Signed: _____

Title of Authorized Signatory of Proposer: _____

State of Texas
County of Galveston

§
§
§

NON-COLLUSION AFFIDAVIT

Before me, the undersigned notary, on this day personally appeared _____ (Affiant), whom being first duly sworn, deposes and certifies that:

- Affiant is the _____ of _____, that
(Individual, Partner, Corporate Officer) (Name of Qualifier)
submitted the attached Qualification in Bid No. **B201022, Jerry J. Esmond Juvenile Justice Center Roof Replacement**
- Affiant is a duly authorized representative of Qualifier and is authorized to make this Non-Collusion Affidavit;
- The attached Qualification is genuine and is not a collusive or sham Qualification;
- The attached Qualification has been independently arrived at without collusion with any other qualifier, bidder, proposer, person, firm, competitor, or potential competitor;
- Qualifier has not colluded, conspired, connived or agreed, directly or indirectly, with any other qualifier, bidder, proposer, person, firm, competitor, or potential competitor, to submit a collusive or sham qualification or that such other qualifier, bidder, proposer, person, firm, competitor, or potential competitor shall refrain from qualifying;
- Qualifier has not in any manner, directly or indirectly, sought by agreement or collusion or communication or conference with any other qualifier, bidder, proposer, person, firm, competitor, or potential competitor to fix the price or prices in the attached Qualification or of the qualification any other qualifier;
- Qualifier has not in any manner, directly or indirectly, sought by agreement or collusion or communication or conference with any other qualifier bidder, proposer, person, firm, competitor, or potential competitor to fix the overhead, profit or cost element of the Qualification price or prices of any other qualifier, or to secure through any collusion, conspiracy, connivance, or unlawful agreement any advantage against Galveston County or any person interested in the proposed contract;
- Affiant has not in any manner, directly or indirectly, sought by agreement or collusion or communication or conference with any other qualifier, bidder, proposer, person, firm, competitor, or potential competitor, paid or agreed to pay any other qualifier, bidder, proposer, person, firm, competitor, or potential competitor any money or anything of value in return for assistance in procuring or attempting to procure a contract or in return for establishing the price or prices in the attached Qualification or the qualification of any other Qualifier; and
- Affiant certifies that Affiant is fully informed regarding the accuracy of the statements contained herein, and under penalties of perjury, certifies and affirms the truth of the statements herein, such penalties being applicable to the Qualifier as well as to Affiant signing on its behalf.

Signature of Affiant

SWORN TO and **SUBSCRIBED** before me this _____ day of _____, 2020.

Notary Public

My Commission Expires: _____

BID FORM
JERRY J. ESMOND JUVENILE JUSTICE CENTER ROOF REPLACEMENT
COUNTY OF GALVESTON, TEXAS

By signing here, the firm does hereby attest that it has fully read the instructions, conditions and general and special provisions and understands them.

THE COMPANY OF: _____

ADDRESS: _____

FEIN (TAX ID): _____

The following shall be returned with your bid. Failure to do so may be ample cause for rejection of bid as non-responsive. It is the responsibility of the Bidder to ensure that bidder has received all addenda.

| Items: | Confirmed (X): |
|---|---------------------------------|
| 1. References (if required) | _____ |
| 2. Addenda, if any | #1_____ #2_____ #3_____ #4_____ |
| 3. One (1) original and three (3) copies of submittal | _____ |
| 4. Bid Form | _____ |
| 5. Vendor Qualification Packet | _____ |
| 6. Debarment Certification Form | _____ |
| 7. Non-Collusion Affidavit | _____ |
| 8. Payment Terms: | _____ net 30 _____ Other |
| 9. Lobbyist Certification | _____ |
| 10. Bid Bond | _____ |
| 11. Bid Forms | _____ |

Person to contact regarding this bid: _____

Title: _____ Phone: _____ Fax: _____

E-mail address: _____

Name of person authorized to bind the Firm: _____

Signature: _____ Date: _____

Title: _____ Phone: _____ Fax: _____

E-mail address: _____

BID FORM
JERRY J. ESMOND JUVENILE JUSTICE CENTER ROOF REPLACEMENT
GALVESTON COUNTY, TEXAS

Bidder shall use this form to provide the information for notice.

1. Contact information for notice:

Name: _____
Address: _____

Telephone Number: _____ Facsimile number: _____

2. If a copy of notice is requested, please complete below:

Name: _____
Address: _____

Telephone Number: _____ Facsimile number: _____

3. If second or more copies are requested for notice, please supplement this form and clearly mark the supplement as "Supplementary Notice Information."

Bidder to submit reference information. Bidder shall use this form to provide minimum required reference information. If Bidder wishes to provide more than the minimum, Bidder should supplement this form and should clearly mark the supplement as "Supplementary Reference Information."

1. References who can attest to the Bidder's capability to carry out the requirements set forth in this bid:

Business Name of Organization: _____
Name of Person: _____
Title of Individual within Organization, if applicable _____
Business address: _____

Telephone number: _____ Facsimile number: _____

Business Name of Organization: _____
Name of Person: _____
Title of Individual within Organization, if applicable _____
Business address: _____

Telephone number: _____ Facsimile number: _____

Business Name of Organization: _____
Name of Person: _____
Title of Individual within Organization, if applicable _____
Business address: _____

Telephone number: _____ Facsimile number: _____

BID FORM
JERRY J. ESMOND JUVENILE JUSTICE CENTER ROOF REPLACEMENT
GALVESTON COUNTY, TEXAS

References of major supplier of Bidder who can speak to the financial capability of the Bidder to carry out the requirements set forth in this bid:

1. Business Name of Supplier _____
Name of Person: _____
Title of Individual within business: _____
Business address: _____

Telephone number: _____ Facsimile number: _____

2. Business Name of Supplier _____
Name of Person: _____
Title of Individual within business: _____
Business address: _____

Telephone number: _____ Facsimile number: _____

3. Business Name of Supplier _____
Name of Person: _____
Title of Individual within business: _____
Business address: _____

Telephone number: _____ Facsimile number: _____

The remainder of this page intentionally left blank

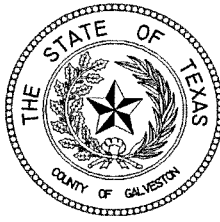

County of Galveston

**ACKNOWLEDGMENT AND CERTIFICATION REGARDING DEBARMENT,
SUSPENSION, AND OTHER INELGIBILITY**

Executive Orders 12549 & 12689 Certification, Debarment and Suspension

Solicitation Number: ITB #B201022

Solicitation Title: Jerry J. Esmond Juvenile Justice Center Roof Replacement

Contractor hereby CERTIFIES that:

Contractor, and all of its principals, is not presently debarred, suspended, proposed for debarment, proposed for suspension, or declared ineligible under Executive Order 12549 or Executive Order 12689, Debarment and Suspension, and is not in any other way ineligible for participation in Federal or State assistance programs;

Contractor, and all of its principals, were not and have not been debarred, suspended, proposed for debarment, proposed for suspension, or declared ineligible under Executive Order 12549 or Executive Order 12689, Debarment and Suspension, and were not and have not been in any other way ineligible for participation in Federal or State assistance programs at the time its' proposal was submitted in the procurement identified herein and at any time since submission of its' proposal;

Contractor has included, and shall continue to include, this certification in all contracts between itself and any sub-contractors in connection with services performed under this contract; **and**

Contractor shall notify Galveston County in writing immediately, through written notification to the Galveston County Purchasing Agent, if Contractor is not in compliance with Executive Order 12549 or 12689 during the term of its contract with Galveston County.

Contractor **Represents** and **Warrants** that the individual executing this Acknowledgment and Certification on its behalf has the full power and authority to do so and can legally bind the Contractor hereto.

Name of Business

Date

By: _____
Signature

Printed Name & Title

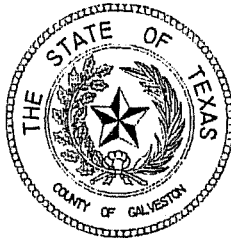

**County of Galveston
Purchasing Department
Vendor Qualification Packet**

(rev. 1.4, September 28, 2017)

All interested parties seeking consideration for qualified vendor status with the County of Galveston should complete and return only the following forms to:

**Galveston County Purchasing Department
722 Moody Avenue, (21st Street), 5th Floor
Galveston, Texas 77550
(409) 770-5371 office
(409) 621-7987 fax**

PEID Form: Person /Entity Information Data

W -9 Form: Request for Taxpayer Identification Number and Certification
(please note that the included form may not be the latest revised form issued by the Internal Revenue Service. Please check the IRS website at <http://www.irs.gov/pub/irs-rd/1045.pdf> for the latest revision of this form.)

CIQ Form: Conflict of Interest Questionnaire
(please note that the included form may not be the latest revised form issued by the State of Texas Ethics Commission. Please check the Texas Ethics Commission website at http://www.ethics.state.tx.us/whatsnew/conflict_forms.htm for the latest revision of this form. Please note that Galveston County Purchasing Agent is not responsible for the filing of this form with the Galveston County Clerk per instructions of the State of Texas Ethics Commission).

Debarment: **CERTIFICATION REGARDING DEBARMENT, SUSPENSION, PROPOSED DEBARMENT, AND OTHER RESPONSIBILITY MATTERS & REQUIREMENT TO REGISTER IN SAM**
Vendors/contractor certifies that neither it, nor any of its Principals, are presently debarred, suspended, proposed for debarment, disqualified, excluded, or in any way declared ineligible for the award of contracts by any Federal agency. Vendor agrees that it shall refund Galveston County for any payments made to Contractor while ineligible. Vendor acknowledges that Contractor's uncured failure to perform under any agreement with the County of Galveston, if such should occur, may result in Contractor being debarred from performing additional work for the County, the respecting State Agency administering the grant funding the contract, if applicable, the State, FEMA or HUD (as applicable), and other Federal and State entities. Further, Vendor has executed the Certification Regarding Debarment, Suspension, Proposed Debarment, and Other Responsibility Matters and returned the fully completed and executed original certification with the submission of this Vendor Qualification Packet. The truthful and fully completed and executed original of the Certification Regarding Debarment, Suspension, Proposed Debarment, and Other Responsibility Matters must be included with the submission of this Vendor Qualification Packet and is a mandatory requirement to become a vendor of Galveston County. Vendor's failure to include the fully completed and executed original of this Certification shall be considered non-compliant with the requirements of this vendor qualification request and grounds for the rejection of vendor's request. Vendor shall immediately notify the County Purchasing Agent if it becomes debarred or suspended, placed on

the Consolidated List of Debarred Contractors, or in any other way becomes ineligible for award of contract by any Federal agency. This Certification is a material fact relied upon by Galveston County; if it is later determined that the vendor did not comply with 2 C.F.R. Part 180 and 2 C.F.R. Part 3000, in addition to the remedies available to Galveston County and the State agency administering a grant, the Federal Government may pursue available remedies, including but not limited to suspension and/or debarment of contractor. If the contract to be awarded pursuant to a Galveston County procurement effort involves the use of Federal funds, then vendor must also be registered in the Federal Contractor Registry through the System for Award Management (SAM) to be eligible for award of contract pursuant to the procurement.

Information regarding the SAM is available at:

<http://www.federalcontractorregistry.com/?gclid=CIG1hf2r8wCFYkCaOoducANZw> or at <https://www.sam.gov/portal/SAM/#1>.

No contract involving the use of Federal funds may be awarded to any vendor unless and until such registration is current and in good standing under SAM. Successful vendors must maintain SAM registration throughout the entire term of any contractual agreement with the County. If a contract involves the use of Federal funds, then vendor must enclose proof of such SAM registration within its response, which is also a mandatory requirement of County procurement policy; failure to enclose such proof shall be considered non-compliant with the requirements of any procurement effort and grounds for the rejection of vendor's response to any procurement efforts (i.e., bid, proposal, or qualifications statement, as applicable).

Certificate(s) of Insurance: If the person or entity seeking qualified vendor status with the County will be performing work at or on any County owned facility and/or property, Certificate(s) of Insurance are required to be submitted prior to performing any work.

Insurance requirements are as follows:

Public Liability and Property Damage Insurance:

Successful vendor agrees to keep in full force and effect, a policy of public liability and property damage insurance issued by a casualty company authorized to do business in the State of Texas, and in standard form approved by the Board of Insurance Commissioners of the State of Texas, with coverage provisions insuring the public from any loss or damage that may arise to any person or property by reason of services rendered by vendor. Vendor shall at its own expense be required to carry the following minimum insurance coverages:

1. For damages arising out of bodily injury to or death of one person in anyone occurrence - one hundred thousand and no/100 dollars (\$100,000.00);
2. For damages arising out of bodily injury to or death of two or more persons in anyone occurrence - three hundred thousand and no/100 dollars (\$300,000.00); and
3. For injury to or destruction of property in anyone occurrence - one hundred thousand and no/100 dollars (\$100,000.00).

This insurance shall be either on an occurrence basis or on a claims made basis. Provided however, that if the coverage is on a claims made basis, then the vendor shall be required to purchase, at the termination of this agreement, tail coverage for the County for the period of the County's relationship with the vendor under this agreement. Such coverage shall be in the amounts set forth in subparagraphs (1), (2), and (3) above.

Worker's Compensation Insurance:

Successful vendor shall also carry in full force Workers' Compensation Insurance policy(ies), if there is more than one employee, for all employees, including but not limited to full time, part time, and emergency employees employed by the vendor. Current insurance certificates certifying that such policies as specified above are in full force and effect shall be furnished by the vendor to the County.

The County of Galveston shall be named as additional insured on policies listed in subparagraphs above and shall be notified of any changes to the policy(ies) during the contractual period.

Insurance is to be placed with insurers having a Best rating of no less than A. The vendor shall furnish the County with certificates of insurance and original endorsements affecting coverage required by these insurance clauses. The certificates and endorsements for each insurance policy are to be signed by a person authorized by the insurer to bind coverage on its behalf. The vendor shall be required to submit annual renewals for the term of any contractual agreement, purchase order or term contract, with Galveston County prior to expiration of any policy.

In addition to the remedies stated herein, the County has the right to pursue other remedies permitted by law or in equity.

The County agrees to provide vendor with reasonable and timely notice of any claim, demand, or cause of action made or brought against the County arising out of or related to utilization of the property. Vendor shall have the right to defend any such claim, demand, or cause of action at its sole cost and expense and within its sole and exclusive discretion. The County agrees not to compromise or settle any claim or cause of action arising out of or related to the utilization of the property without the prior written consent of the vendor.

In no event shall the County be liable for any damage to or destruction of any property belonging to the vendor unless specified in writing and agreed upon by both parties.

Procurement Policy - Special Note:

Understand that it is, according to Texas Local Government Code, Section 262.011, Purchasing Agents, subsections (d), (e), and (f), the sole responsibility of the Purchasing Agent to supervise all procurement transactions.

Therefore, be advised that all procurement transactions require proper authorization in the form of a Galveston County purchase order from the Purchasing Agent's office prior to commitment to deliver supplies, materials, equipment, including contracts for repair, service, and maintenance agreements. Any commitments made without proper authorization from the Purchasing Agent's office, pending Commissioners' Court approval, may become the sole responsibility of the individual making the commitment including the obligation of payment.

Code of Ethics - Statement of Purchasing Policy:

Public employment is a public trust. It is the policy of Galveston County to promote and balance the objective of protecting the County's integrity and the objective of facilitating the recruitment and retention of personnel needed by Galveston County. Such policy is implemented by prescribing essential standards of ethical conduct without creating unnecessary obstacles to entering public office.

Public employees must discharge their duties impartially so as to assure fair competitive access to governmental procurement by responsible contractors. Moreover, they should conduct themselves in such a manner as to foster public confidence in the integrity of the Galveston County procurement organization.

To achieve the purpose of these instructions, it is essential that those doing business with Galveston County also observe the ethical standards prescribed here.

General Ethical Standards: It shall be a breach of ethics to attempt to realize personal gain through public employment with Galveston County by any conduct inconsistent with the proper discharge of the employee's duties.

It shall be a breach of ethics to attempt to influence any public employee of Galveston County to breach the standards of ethical conduct set forth in this code.

It shall be a breach of ethics for any employee of Galveston County to participate directly or indirectly in procurement when the employee knows that:

- The employee or any member of the employee's immediate family has a financial interest pertaining to the procurement.
- A business or organization in which the employee, or any member of the employee's immediate family, has a financial interest pertaining to the procurement.
- Any other person, business or organization with which the employee or any member of the employee's immediate family is negotiating or has an arrangement concerning prospective employment is involved in the procurement.

Gratuities: It shall be a breach of ethics to offer, give or agree to give any employee of Galveston County, or for any employee or former employee of Galveston County to solicit, demand, accept or agree to accept from another person, a gratuity or an offer of employment in connection with any decision, approval, disapproval, recommendation, preparation of any part of a program requirement or purchase request, influencing the content of any specification or procurement standard, rendering of advice, investigation, auditing, or in any other advisory capacity in any program requirement or a contract or subcontract, or to any solicitation or proposal therefore pending before this government.

Kickbacks: It shall be a breach of ethics for any payment, gratuity or offer of employment to be made by or on behalf of a subcontractor under a contract to the prime contractor or higher tier subcontractor for any contract for Galveston County, or any person associated therewith, as an inducement for the award of a subcontract or order.

Contract Clause: The prohibition against gratuities and kickbacks prescribed above shall be conspicuously set forth in every contract and solicitation by Galveston County.

Confidential Information: It shall be a breach of ethics for any employee or former employee of Galveston County to knowingly use confidential information for actual or anticipated personal gain, or for the actual or anticipated gain of any person.

Questions/Concerns:

If you have any questions or concerns regarding the information or instructions contained within this packet, please contact any member of the Purchasing Department staff at (409) 770-5371.

CONFLICT OF INTEREST DISCLOSURE REPORTING

Proposer may be required under Chapter 176 of the Texas Local Government Code to complete and file a conflict of interest questionnaire (CIQ Form). If so, the completed CIQ Form must be filed with the County Clerk of Galveston County, Texas.

If Proposer has an employment or other business relationship with an officer of Galveston County or with a family member of an officer of Galveston County that results in the officer or family member of the officer receiving taxable income that exceeds \$2,500.00 during the preceding 12-month period, then Proposer **MUST** complete a CIQ Form and file the original of the CIQ Form with the County Clerk of Galveston County.

If Proposer has given an officer of Galveston County or a family member of an officer of Galveston County one or more gifts with an aggregate value of more than \$250.00 during the preceding 12-months, then Proposer **MUST** complete a CIQ Form and file the original of the CIQ Form with the County Clerk of Galveston County.

The Galveston County Clerk has offices at the following locations:

Galveston County Clerk
Galveston County Justice Center, Suite 2001
600 59th Street
Galveston, Texas 77551

Galveston County Clerk
North County Annex, 1st Floor
174 Calder Road
League City, Texas 77573

Again, if Proposer is required to file a CIQ Form, the original completed form is filed with the Galveston County Clerk (not the Purchasing Agent).

For Proposer's convenience, a blank CIQ Form is enclosed with this proposal. Blank CIQ Forms may also be obtained by visiting the Galveston County Clerk's website and/or the Purchasing Agent's website - both of these web sites are linked to the Galveston County homepage, at <http://www.co.galveston.tx.us>.

As well, blank CIQ Forms may be obtained by visiting the Texas Ethics Commission website, specifically at <http://www.ethics.state.tx.us/whatsnew/conflictforms.htm>.

Chapter 176 specifies deadlines for the filing of CIQ Forms (both initial filings and updated filings).

It is Proposer's sole responsibility to file a true and complete CIQ Form with the Galveston County Clerk if Proposer is required to file by the requirements of Chapter 176. Proposer is advised that it is an offense to fail to comply with the disclosure reporting requirements dictated under Chapter 176 of the Texas Local Government Code.

If you have questions about compliance with Chapter 176, please consult your own legal counsel. Compliance is the individual responsibility of each person, business, and agent who is subject to Chapter 176 of the Texas Local Government Code.

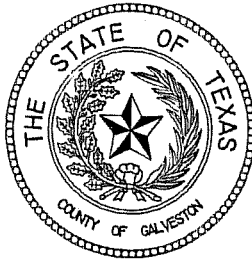

COUNTY of GALVESTON
Purchasing Department

rev. 1.3, March 29, 2010

| | |
|-------------------|--|
| FORM PEID: | Request for Person-Entity Identification Data |
|-------------------|--|

Instructions: Please type or print clearly when completing sections 1 thru 4 and return completed form to:

Galveston County Purchasing Agent
 722 Moody Avenue (21 st. Street), 5th Floor
 Galveston, Texas 77550
 (409) 770-5371
prodoc@co.galveston.tx.us

| | | | | |
|----|---------------------------------|--|---------------|---------------|
| 1. | Business Name: | | | |
| | Attention Line: | | | |
| 2. | Physical Address: | | | |
| | City: | | State: | Zip+4: |
| | | | | |
| 3. | Billing / Remit Address: | | | |
| | City: | | State: | Zip+4 |
| | | | | |
| 4. | Main Contact Person: | | | |
| | Main Phone Number: | | | |
| | Fax Number: | | | |
| | E-mail Address: | | | |

Areas below are for County use only.

| | | |
|--------------------------------------|--|--------------------------------------|
| Requested By: | Phone / Ext. # | |
| Department: | Date: | |
| Action Requested - Check One: | IFAS PEID Vendor Number: | |
| <input type="checkbox"/> Add New | <input type="checkbox"/> Change Data | <input type="checkbox"/> Re-activate |
| <input type="checkbox"/> Inactivate | <input type="checkbox"/> Employee | <input type="checkbox"/> Attorney |
| <input type="checkbox"/> Landlord | <input type="checkbox"/> Foster Parent | <input type="checkbox"/> Refund |
| <input type="checkbox"/> OneTime | <input type="checkbox"/> Foster Child | |

Request for Taxpayer Identification Number and Certification

**Give Form to the
 requester. Do not
 send to the IRS.**

Print or type
 See Specific Instructions on page 2.

| | | |
|--|---|---|
| | 1 Name (as shown on your income tax return). Name is required on this line; do not leave this line blank. | |
| | 2 Business name/disregarded entity name, if different from above | |
| | 3 Check appropriate box for federal tax classification; check only one of the following seven boxes: <input type="checkbox"/> Individual/sole proprietor or single-member LLC <input type="checkbox"/> C Corporation <input type="checkbox"/> S Corporation <input type="checkbox"/> Partnership <input type="checkbox"/> Trust/estate <input type="checkbox"/> Limited liability company. Enter the tax classification (C=C corporation, S=S corporation, P=partnership) ▶ _____ Note. For a single-member LLC that is disregarded, do not check LLC; check the appropriate box in the line above for the tax classification of the single-member owner. <input type="checkbox"/> Other (see instructions) ▶ _____ | 4 Exemptions (codes apply only to certain entities, not individuals; see instructions on page 3): Exempt payee code (if any) _____ Exemption from FATCA reporting code (if any) _____ <i>(Applies to accounts maintained outside the U.S.)</i> |
| | 5 Address (number, street, and apt. or suite no.) | Requester's name and address (optional) |
| | 6 City, state, and ZIP code | |
| | 7 List account number(s) here (optional) | |

Part I Taxpayer Identification Number (TIN)

Enter your TIN in the appropriate box. The TIN provided must match the name given on line 1 to avoid backup withholding. For individuals, this is generally your social security number (SSN). However, for a resident alien, sole proprietor, or disregarded entity, see the Part I instructions on page 3. For other entities, it is your employer identification number (EIN). If you do not have a number, see *How to get a TIN* on page 3.

Note. If the account is in more than one name, see the instructions for line 1 and the chart on page 4 for guidelines on whose number to enter.

| | | | | | | | | | |
|--------------------------------|--|--|--|--|--|--|--|--|--|
| Social security number | | | | | | | | | |
| | | | | | | | | | |
| or | | | | | | | | | |
| Employer identification number | | | | | | | | | |
| | | | | | | | | | |

Part II Certification

Under penalties of perjury, I certify that:

1. The number shown on this form is my correct taxpayer identification number (or I am waiting for a number to be issued to me); and
2. I am not subject to backup withholding because: (a) I am exempt from backup withholding, or (b) I have not been notified by the Internal Revenue Service (IRS) that I am subject to backup withholding as a result of a failure to report all interest or dividends, or (c) the IRS has notified me that I am no longer subject to backup withholding; and
3. I am a U.S. citizen or other U.S. person (defined below); and
4. The FATCA code(s) entered on this form (if any) indicating that I am exempt from FATCA reporting is correct.

Certification instructions. You must cross out item 2 above if you have been notified by the IRS that you are currently subject to backup withholding because you have failed to report all interest and dividends on your tax return. For real estate transactions, item 2 does not apply. For mortgage interest paid, acquisition or abandonment of secured property, cancellation of debt, contributions to an individual retirement arrangement (IRA), and generally, payments other than interest and dividends, you are not required to sign the certification, but you must provide your correct TIN. See the instructions on page 3.

| | | |
|------------------|----------------------------------|--------------|
| Sign Here | Signature of U.S. person ▶ _____ | Date ▶ _____ |
|------------------|----------------------------------|--------------|

General Instructions

Section references are to the Internal Revenue Code unless otherwise noted.
Future developments. Information about developments affecting Form W-9 (such as legislation enacted after we release it) is at www.irs.gov/fw9.

Purpose of Form

An individual or entity (Form W-9 requester) who is required to file an information return with the IRS must obtain your correct taxpayer identification number (TIN) which may be your social security number (SSN), individual taxpayer identification number (ITIN), adoption taxpayer identification number (ATIN), or employer identification number (EIN), to report on an information return the amount paid to you, or other amount reportable on an information return. Examples of information returns include, but are not limited to, the following:

- Form 1099-INT (interest earned or paid)
- Form 1099-DIV (dividends, including those from stocks or mutual funds)
- Form 1099-MISC (various types of income, prizes, awards, or gross proceeds)
- Form 1099-B (stock or mutual fund sales and certain other transactions by brokers)
- Form 1099-S (proceeds from real estate transactions)
- Form 1099-K (merchant card and third party network transactions)

- Form 1098 (home mortgage interest), 1098-E (student loan interest), 1098-T (tuition)
 - Form 1099-C (canceled debt)
 - Form 1099-A (acquisition or abandonment of secured property)
- Use Form W-9 only if you are a U.S. person (including a resident alien), to provide your correct TIN.
- If you do not return Form W-9 to the requester with a TIN, you might be subject to backup withholding. See What is backup withholding? on page 2.*
- By signing the filled-out form, you:
1. Certify that the TIN you are giving is correct (or you are waiting for a number to be issued),
 2. Certify that you are not subject to backup withholding, or
 3. Claim exemption from backup withholding if you are a U.S. exempt payee. If applicable, you are also certifying that as a U.S. person, your allocable share of any partnership income from a U.S. trade or business is not subject to the withholding tax on foreign partners' share of effectively connected income, and
 4. Certify that FATCA code(s) entered on this form (if any) indicating that you are exempt from the FATCA reporting, is correct. See *What is FATCA reporting?* on page 2 for further information.

Note. If you are a U.S. person and a requester gives you a form other than Form W-9 to request your TIN, you must use the requester's form if it is substantially similar to this Form W-9.

Definition of a U.S. person. For federal tax purposes, you are considered a U.S. person if you are:

- An individual who is a U.S. citizen or U.S. resident alien;
- A partnership, corporation, company, or association created or organized in the United States or under the laws of the United States;
- An estate (other than a foreign estate); or
- A domestic trust (as defined in Regulations section 301.7701-7).

Special rules for partnerships. Partnerships that conduct a trade or business in the United States are generally required to pay a withholding tax under section 1446 on any foreign partners' share of effectively connected taxable income from such business. Further, in certain cases where a Form W-9 has not been received, the rules under section 1446 require a partnership to presume that a partner is a foreign person, and pay the section 1446 withholding tax. Therefore, if you are a U.S. person that is a partner in a partnership conducting a trade or business in the United States, provide Form W-9 to the partnership to establish your U.S. status and avoid section 1446 withholding on your share of partnership income.

In the cases below, the following person must give Form W-9 to the partnership for purposes of establishing its U.S. status and avoiding withholding on its allocable share of net income from the partnership conducting a trade or business in the United States:

- In the case of a disregarded entity with a U.S. owner, the U.S. owner of the disregarded entity and not the entity;
- In the case of a grantor trust with a U.S. grantor or other U.S. owner, generally, the U.S. grantor or other U.S. owner of the grantor trust and not the trust; and
- In the case of a U.S. trust (other than a grantor trust), the U.S. trust (other than a grantor trust) and not the beneficiaries of the trust.

Foreign person. If you are a foreign person or the U.S. branch of a foreign bank that has elected to be treated as a U.S. person, do not use Form W-9. Instead, use the appropriate Form W-8 or Form 8233 (see Publication 515, Withholding of Tax on Nonresident Aliens and Foreign Entities).

Nonresident alien who becomes a resident alien. Generally, only a nonresident alien individual may use the terms of a tax treaty to reduce or eliminate U.S. tax on certain types of income. However, most tax treaties contain a provision known as a "saving clause." Exceptions specified in the saving clause may permit an exemption from tax to continue for certain types of income even after the payee has otherwise become a U.S. resident alien for tax purposes.

If you are a U.S. resident alien who is relying on an exception contained in the saving clause of a tax treaty to claim an exemption from U.S. tax on certain types of income, you must attach a statement to Form W-9 that specifies the following five items:

1. The treaty country. Generally, this must be the same treaty under which you claimed exemption from tax as a nonresident alien.
2. The treaty article addressing the income.
3. The article number (or location) in the tax treaty that contains the saving clause and its exceptions.
4. The type and amount of income that qualifies for the exemption from tax.
5. Sufficient facts to justify the exemption from tax under the terms of the treaty article.

Example. Article 20 of the U.S.-China income tax treaty allows an exemption from tax for scholarship income received by a Chinese student temporarily present in the United States. Under U.S. law, this student will become a resident alien for tax purposes if his or her stay in the United States exceeds 5 calendar years. However, paragraph 2 of the first Protocol to the U.S.-China treaty (dated April 30, 1984) allows the provisions of Article 20 to continue to apply even after the Chinese student becomes a resident alien of the United States. A Chinese student who qualifies for this exception (under paragraph 2 of the first protocol) and is relying on this exception to claim an exemption from tax on his or her scholarship or fellowship income would attach to Form W-9 a statement that includes the information described above to support that exemption.

If you are a nonresident alien or a foreign entity, give the requester the appropriate completed Form W-8 or Form 8233.

Backup Withholding

What is backup withholding? Persons making certain payments to you must under certain conditions withhold and pay to the IRS 28% of such payments. This is called "backup withholding." Payments that may be subject to backup withholding include interest, tax-exempt interest, dividends, broker and barter exchange transactions, rents, royalties, nonemployee pay, payments made in settlement of payment card and third party network transactions, and certain payments from fishing boat operators. Real estate transactions are not subject to backup withholding.

You will not be subject to backup withholding on payments you receive if you give the requester your correct TIN, make the proper certifications, and report all your taxable interest and dividends on your tax return.

Payments you receive will be subject to backup withholding if:

1. You do not furnish your TIN to the requester,
2. You do not certify your TIN when required (see the Part II instructions on page 3 for details),

3. The IRS tells the requester that you furnished an incorrect TIN,

4. The IRS tells you that you are subject to backup withholding because you did not report all your interest and dividends on your tax return (for reportable interest and dividends only), or

5. You do not certify to the requester that you are not subject to backup withholding under 4 above (for reportable interest and dividend accounts opened after 1983 only).

Certain payees and payments are exempt from backup withholding. See *Exempt payee code* on page 3 and the separate instructions for the Requester of Form W-9 for more information.

Also see *Special rules for partnerships* above.

What is FATCA reporting?

The Foreign Account Tax Compliance Act (FATCA) requires a participating foreign financial institution to report all United States account holders that are specified United States persons. Certain payees are exempt from FATCA reporting. See *Exemption from FATCA reporting code* on page 3 and the instructions for the Requester of Form W-9 for more information.

Updating Your Information

You must provide updated information to any person to whom you claimed to be an exempt payee if you are no longer an exempt payee and anticipate receiving reportable payments in the future from this person. For example, you may need to provide updated information if you are a C corporation that elects to be an S corporation, or if you no longer are tax exempt. In addition, you must furnish a new Form W-9 if the name or TIN changes for the account; for example, if the grantor of a grantor trust dies.

Penalties

Failure to furnish TIN. If you fail to furnish your correct TIN to a requester, you are subject to a penalty of \$50 for each such failure unless your failure is due to reasonable cause and not to willful neglect.

Civil penalty for false information with respect to withholding. If you make a false statement with no reasonable basis that results in no backup withholding, you are subject to a \$500 penalty.

Criminal penalty for falsifying information. Willfully falsifying certifications or affirmations may subject you to criminal penalties including fines and/or imprisonment.

Misuse of TINs. If the requester discloses or uses TINs in violation of federal law, the requester may be subject to civil and criminal penalties.

Specific Instructions

Line 1

You must enter one of the following on this line; do not leave this line blank. The name should match the name on your tax return.

If this Form W-9 is for a joint account, list first, and then circle, the name of the person or entity whose number you entered in Part I of Form W-9.

a. **Individual.** Generally, enter the name shown on your tax return. If you have changed your last name without informing the Social Security Administration (SSA) of the name change, enter your first name, the last name as shown on your social security card, and your new last name.

Note. ITIN applicant: Enter your individual name as it was entered on your Form W-7 application, line 1a. This should also be the same as the name you entered on the Form 1040/1040A/1040EZ you filed with your application.

b. **Sole proprietor or single-member LLC.** Enter your individual name as shown on your 1040/1040A/1040EZ on line 1. You may enter your business, trade, or "doing business as" (DBA) name on line 2.

c. **Partnership, LLC that is not a single-member LLC, C Corporation, or S Corporation.** Enter the entity's name as shown on the entity's tax return on line 1 and any business, trade, or DBA name on line 2.

d. **Other entities.** Enter your name as shown on required U.S. federal tax documents on line 1. This name should match the name shown on the charter or other legal document creating the entity. You may enter any business, trade, or DBA name on line 2.

e. **Disregarded entity.** For U.S. federal tax purposes, an entity that is disregarded as an entity separate from its owner is treated as a "disregarded entity." See Regulations section 301.7701-2(c)(2)(iii). Enter the owner's name on line 1. The name of the entity entered on line 1 should never be a disregarded entity. The name on line 1 should be the name shown on the income tax return on which the income should be reported. For example, if a foreign LLC that is treated as a disregarded entity for U.S. federal tax purposes has a single owner that is a U.S. person, the U.S. owner's name is required to be provided on line 1. If the direct owner of the entity is also a disregarded entity, enter the first owner that is not disregarded for federal tax purposes. Enter the disregarded entity's name on line 2, "Business name/disregarded entity name." If the owner of the disregarded entity is a foreign person, the owner must complete an appropriate Form W-8 instead of a Form W-9. This is the case even if the foreign person has a U.S. TIN.

Line 2

If you have a business name, trade name, DBA name, or disregarded entity name, you may enter it on line 2.

Line 3

Check the appropriate box in line 3 for the U.S. federal tax classification of the person whose name is entered on line 1. Check only one box in line 3.

Limited Liability Company (LLC). If the name on line 1 is an LLC treated as a partnership for U.S. federal tax purposes, check the "Limited Liability Company" box and enter "P" in the space provided. If the LLC has filed Form 8832 or 2553 to be taxed as a corporation, check the "Limited Liability Company" box and in the space provided enter "C" for C corporation or "S" for S corporation. If it is a single-member LLC that is a disregarded entity, do not check the "Limited Liability Company" box; instead check the first box in line 3 "Individual/sole proprietor or single-member LLC."

Line 4, Exemptions

If you are exempt from backup withholding and/or FATCA reporting, enter in the appropriate space in line 4 any code(s) that may apply to you.

Exempt payee code.

- Generally, individuals (including sole proprietors) are not exempt from backup withholding.
- Except as provided below, corporations are exempt from backup withholding for certain payments, including interest and dividends.
- Corporations are not exempt from backup withholding for payments made in settlement of payment card or third party network transactions.
- Corporations are not exempt from backup withholding with respect to attorneys' fees or gross proceeds paid to attorneys, and corporations that provide medical or health care services are not exempt with respect to payments reportable on Form 1099-MISC.

The following codes identify payees that are exempt from backup withholding. Enter the appropriate code in the space in line 4.

- 1—An organization exempt from tax under section 501(a), any IRA, or a custodial account under section 403(b)(7) if the account satisfies the requirements of section 401(f)(2)
- 2—The United States or any of its agencies or instrumentalities
- 3—A state, the District of Columbia, a U.S. commonwealth or possession, or any of their political subdivisions or instrumentalities
- 4—A foreign government or any of its political subdivisions, agencies, or instrumentalities
- 5—A corporation
- 6—A dealer in securities or commodities required to register in the United States, the District of Columbia, or a U.S. commonwealth or possession
- 7—A futures commission merchant registered with the Commodity Futures Trading Commission
- 8—A real estate investment trust
- 9—An entity registered at all times during the tax year under the Investment Company Act of 1940
- 10—A common trust fund operated by a bank under section 584(a)
- 11—A financial institution
- 12—A middleman known in the investment community as a nominee or custodian
- 13—A trust exempt from tax under section 664 or described in section 4947

The following chart shows types of payments that may be exempt from backup withholding. The chart applies to the exempt payees listed above, 1 through 13.

| IF the payment is for . . . | THEN the payment is exempt for . . . |
|--|---|
| Interest and dividend payments | All exempt payees except for 7 |
| Broker transactions | Exempt payees 1 through 4 and 6 through 11 and all C corporations. S corporations must not enter an exempt payee code because they are exempt only for sales of noncovered securities acquired prior to 2012. |
| Barter exchange transactions and patronage dividends | Exempt payees 1 through 4 |
| Payments over \$600 required to be reported and direct sales over \$5,000 ¹ | Generally, exempt payees 1 through 5 ² |
| Payments made in settlement of payment card or third party network transactions | Exempt payees 1 through 4 |

¹ See Form 1099-MISC, Miscellaneous Income, and its instructions.

² However, the following payments made to a corporation and reportable on Form 1099-MISC are not exempt from backup withholding: medical and health care payments, attorneys' fees, gross proceeds paid to an attorney reportable under section 6045(f), and payments for services paid by a federal executive agency.

Exemption from FATCA reporting code. The following codes identify payees that are exempt from reporting under FATCA. These codes apply to persons submitting this form for accounts maintained outside of the United States by certain foreign financial institutions. Therefore, if you are only submitting this form for an account you hold in the United States, you may leave this field blank. Consult with the person requesting this form if you are uncertain if the financial institution is subject to these requirements. A requester may indicate that a code is not required by providing you with a Form W-9 with "Not Applicable" (or any similar indication) written or printed on the line for a FATCA exemption code.

- A—An organization exempt from tax under section 501(a) or any individual retirement plan as defined in section 7701(a)(37)
- B—The United States or any of its agencies or instrumentalities
- C—A state, the District of Columbia, a U.S. commonwealth or possession, or any of their political subdivisions or instrumentalities
- D—A corporation the stock of which is regularly traded on one or more established securities markets, as described in Regulations section 1.1472-1(c)(1)(i)
- E—A corporation that is a member of the same expanded affiliated group as a corporation described in Regulations section 1.1472-1(c)(1)(i)
- F—A dealer in securities, commodities, or derivative financial instruments (including notional principal contracts, futures, forwards, and options) that is registered as such under the laws of the United States or any state
- G—A real estate investment trust
- H—A regulated investment company as defined in section 851 or an entity registered at all times during the tax year under the Investment Company Act of 1940
- I—A common trust fund as defined in section 584(a)
- J—A bank as defined in section 581
- K—A broker
- L—A trust exempt from tax under section 664 or described in section 4947(a)(1)
- M—A tax exempt trust under a section 403(b) plan or section 457(g) plan

Note. You may wish to consult with the financial institution requesting this form to determine whether the FATCA code and/or exempt payee code should be completed.

Line 5

Enter your address (number, street, and apartment or suite number). This is where the requester of this Form W-9 will mail your information returns.

Line 6

Enter your city, state, and ZIP code.

Part I. Taxpayer Identification Number (TIN)

Enter your TIN in the appropriate box. If you are a resident alien and you do not have and are not eligible to get an SSN, your TIN is your IRS individual taxpayer identification number (ITIN). Enter it in the social security number box. If you do not have an ITIN, see *How to get a TIN* below.

If you are a sole proprietor and you have an EIN, you may enter either your SSN or EIN. However, the IRS prefers that you use your SSN.

If you are a single-member LLC that is disregarded as an entity separate from its owner (see *Limited Liability Company (LLC)* on this page), enter the owner's SSN (or EIN, if the owner has one). Do not enter the disregarded entity's EIN. If the LLC is classified as a corporation or partnership, enter the entity's EIN.

Note. See the chart on page 4 for further clarification of name and TIN combinations.

How to get a TIN. If you do not have a TIN, apply for one immediately. To apply for an SSN, get Form SS-5, Application for a Social Security Card, from your local SSA office or get this form online at www.ssa.gov. You may also get this form by calling 1-800-772-1213. Use Form W-7, Application for IRS Individual Taxpayer Identification Number, to apply for an ITIN, or Form SS-4, Application for Employer Identification Number, to apply for an EIN. You can apply for an EIN online by accessing the IRS website at www.irs.gov/businesses and clicking on Employer Identification Number (EIN) under Starting a Business. You can get Forms W-7 and SS-4 from the IRS by visiting IRS.gov or by calling 1-800-TAX-FORM (1-800-829-3676).

If you are asked to complete Form W-9 but do not have a TIN, apply for a TIN and write "Applied For" in the space for the TIN, sign and date the form, and give it to the requester. For interest and dividend payments, and certain payments made with respect to readily tradable instruments, generally you will have 60 days to get a TIN and give it to the requester before you are subject to backup withholding on payments. The 60-day rule does not apply to other types of payments. You will be subject to backup withholding on all such payments until you provide your TIN to the requester.

Note. Entering "Applied For" means that you have already applied for a TIN or that you intend to apply for one soon.

Caution: A disregarded U.S. entity that has a foreign owner must use the appropriate Form W-8.

Part II. Certification

To establish to the withholding agent that you are a U.S. person, or resident alien, sign Form W-9. You may be requested to sign by the withholding agent even if items 1, 4, or 5 below indicate otherwise.

For a joint account, only the person whose TIN is shown in Part I should sign (when required). In the case of a disregarded entity, the person identified on line 1 must sign. Exempt payees, see *Exempt payee code* earlier.

Signature requirements. Complete the certification as indicated in Items 1 through 5 below.

1. **Interest, dividend, and barter exchange accounts opened before 1984 and broker accounts considered active during 1983.** You must give your correct TIN, but you do not have to sign the certification.
2. **Interest, dividend, broker, and barter exchange accounts opened after 1983 and broker accounts considered inactive during 1983.** You must sign the certification or backup withholding will apply. If you are subject to backup withholding and you are merely providing your correct TIN to the requester, you must cross out item 2 in the certification before signing the form.
3. **Real estate transactions.** You must sign the certification. You may cross out item 2 of the certification.
4. **Other payments.** You must give your correct TIN, but you do not have to sign the certification unless you have been notified that you have previously given an incorrect TIN. "Other payments" include payments made in the course of the requester's trade or business for rents, royalties, goods (other than bills for merchandise), medical and health care services (including payments to corporations), payments to a nonemployee for services, payments made in settlement of payment card and third party network transactions, payments to certain fishing boat crew members and fishermen, and gross proceeds paid to attorneys (including payments to corporations).
5. **Mortgage interest paid by you, acquisition or abandonment of secured property, cancellation of debt, qualified tuition program payments (under section 529), IRA, Coverdell ESA, Archer MSA or HSA contributions or distributions, and pension distributions.** You must give your correct TIN, but you do not have to sign the certification.

What Name and Number To Give the Requester

| For this type of account: | Give name and SSN of: |
|---|---|
| 1. Individual | The individual |
| 2. Two or more individuals (joint account) | The actual owner of the account or, if combined funds, the first individual on the account ¹ |
| 3. Custodian account of a minor (Uniform Gift to Minors Act) | The minor ² |
| 4. a. The usual revocable savings trust (grantor is also trustee) | The grantor-trustee ¹ |
| b. So-called trust account that is not a legal or valid trust under state law | The actual owner ¹ |
| 5. Sole proprietorship or disregarded entity owned by an individual | The owner ¹ |
| 6. Grantor trust filing under Optional Form 1099 Filing Method 1 (see Regulations section 1.671-4(b)(2)(i)(A)) | The grantor ¹ |
| For this type of account: | Give name and EIN of: |
| 7. Disregarded entity not owned by an individual | The owner |
| 8. A valid trust, estate, or pension trust | Legal entity ⁴ |
| 9. Corporation or LLC electing corporate status on Form 8832 or Form 2553 | The corporation |
| 10. Association, club, religious, charitable, educational, or other tax-exempt organization | The organization |
| 11. Partnership or multi-member LLC | The partnership |
| 12. A broker or registered nominee | The broker or nominee |
| 13. Account with the Department of Agriculture in the name of a public entity (such as a state or local government, school district, or prison) that receives agricultural program payments | The public entity |
| 14. Grantor trust filing under the Form 1041 Filing Method or the Optional Form 1099 Filing Method 2 (see Regulations section 1.671-4(b)(2)(i)(B)) | The trust |

¹ List first and circle the name of the person whose number you furnish. If only one person on a joint account has an SSN, that person's number must be furnished.

² Circle the minor's name and furnish the minor's SSN.

³ You must show your individual name and you may also enter your business or DBA name on the "Business name/disregarded entity" name line. You may use either your SSN or EIN (if you have one), but the IRS encourages you to use your SSN.

⁴ List first and circle the name of the trust, estate, or pension trust. (Do not furnish the TIN of the personal representative or trustee unless the legal entity itself is not designated in the account title.) Also see *Special rules for partnerships* on page 2.

*Note. Grantor also must provide a Form W-9 to trustee of trust.

Note. If no name is circled when more than one name is listed, the number will be considered to be that of the first name listed.

Secure Your Tax Records from Identity Theft

Identity theft occurs when someone uses your personal information such as your name, SSN, or other identifying information, without your permission, to commit fraud or other crimes. An identity thief may use your SSN to get a job or may file a tax return using your SSN to receive a refund.

To reduce your risk:

- Protect your SSN,
- Ensure your employer is protecting your SSN, and
- Be careful when choosing a tax preparer.

If your tax records are affected by identity theft and you receive a notice from the IRS, respond right away to the name and phone number printed on the IRS notice or letter.

If your tax records are not currently affected by identity theft but you think you are at risk due to a lost or stolen purse or wallet, questionable credit card activity or credit report, contact the IRS Identity Theft Hotline at 1-800-908-4490 or submit Form 14039.

For more information, see Publication 4535, Identity Theft Prevention and Victim Assistance.

Victims of identity theft who are experiencing economic harm or a system problem, or are seeking help in resolving tax problems that have not been resolved through normal channels, may be eligible for Taxpayer Advocate Service (TAS) assistance. You can reach TAS by calling the TAS toll-free case intake line at 1-877-777-4778 or TTY/TDD 1-800-829-4059.

Protect yourself from suspicious emails or phishing schemes. Phishing is the creation and use of email and websites designed to mimic legitimate business emails and websites. The most common act is sending an email to a user falsely claiming to be an established legitimate enterprise in an attempt to scam the user into surrendering private information that will be used for identity theft.

The IRS does not initiate contacts with taxpayers via emails. Also, the IRS does not request personal detailed information through email or ask taxpayers for the PIN numbers, passwords, or similar secret access information for their credit card, bank, or other financial accounts.

If you receive an unsolicited email claiming to be from the IRS, forward this message to phishing@irs.gov. You may also report misuse of the IRS name, logo, or other IRS property to the Treasury Inspector General for Tax Administration (TIGTA) at 1-800-366-4484. You can forward suspicious emails to the Federal Trade Commission at: spam@uce.gov or contact them at www.ftc.gov/idtheft or 1-877-IDTHEFT (1-877-438-4338).

Visit IRS.gov to learn more about identity theft and how to reduce your risk.

Privacy Act Notice

Section 6109 of the Internal Revenue Code requires you to provide your correct TIN to persons (including federal agencies) who are required to file information returns with the IRS to report interest, dividends, or certain other income paid to you; mortgage interest you paid; the acquisition or abandonment of secured property; the cancellation of debt; or contributions you made to an IRA, Archer MSA, or HSA. The person collecting this form uses the information on the form to file information returns with the IRS, reporting the above information. Routine uses of this information include giving it to the Department of Justice for civil and criminal litigation and to cities, states, the District of Columbia, and U.S. commonwealths and possessions for use in administering their laws. The information also may be disclosed to other countries under a treaty, to federal and state agencies to enforce civil and criminal laws, or to federal law enforcement and intelligence agencies to combat terrorism. You must provide your TIN whether or not you are required to file a tax return. Under section 3406, payers must generally withhold a percentage of taxable interest, dividend, and certain other payments to a payee who does not give a TIN to the payer. Certain penalties may also apply for providing false or fraudulent information.

CONFLICT OF INTEREST QUESTIONNAIRE

FORM CIQ

For vendor or other person doing business with local governmental entity

This questionnaire reflects changes made to the law by H.B. 1491, 80th Leg., Regular Session.

This questionnaire is being filed in accordance with Chapter 176, Local Government Code by a person who has a business relationship as defined by Section 176.001 (1-a) with a local governmental entity and the person meets requirements under Section 176.006(a).

By law this questionnaire must be filed with the records administrator of the local governmental entity not later than the 7th business day after the date the person becomes aware of facts that require the statement to be filed. See Section 176.006, Local Government Code.

A person commits an offense if the person knowingly violates Section 176.006, Local Government Code. An offense under this section is a Class C misdemeanor.

OFFICE USE ONLY

Date Received

1 Name of person who has a business relationship with local governmental entity.

2 Check this box if you are filing an update to a previously filed questionnaire.

(The law requires that you file an updated completed questionnaire with the appropriate filing authority not later than the 7th business day after the date the originally filed questionnaire becomes incomplete or inaccurate.)

3 Name of local government officer with whom filer has employment or business relationship.

Name of Officer

This section (Item 3 including subparts A, B, C & D) must be completed for each *officer* with whom the filer has an employment or other business relationship as defined by Section 176.001 (1-a), Local Government Code. Attach additional pages to this Form CIQ as necessary.

A. Is the local government officer named in this section receiving or likely to receive taxable income, other than investment income, from the filer of the questionnaire?

Yes

NO

B. Is the filer of the questionnaire receiving or likely to receive taxable income, other than investment income, from or at the direction of the local government *officer* named in this section AND the taxable income is not received from the local governmental entity?

Yes

NO

C. Is the filer of this questionnaire employed by a corporation or other business entity with respect to which the local government officer serves as an *officer* or director, or holds an ownership of 10 percent or more?

Yes

NO

D. Describe each employment or business relationship with the local government *officer* named in this section.

4

Signature of person doing business with the governmental entity

Date

PROJECT MANUAL

Including Technical Specifications and Drawings

FOR:

Galveston County
Juvenile Justice Center Roof Replacement & Waterproofing
6101 Attwater Ave.
Texas City, Texas 77590

October 28, 2019



OWNER:

Galveston County
722 Moody Avenue
Galveston, TX 77550

OWNER'S REPRESENTATIVE:

Mr. Will Riordan
Director of Facilities Services & Maintenance
722 Moody Avenue – 6th Floor
Galveston, TX 77550
Phone: 409-765-2643
Email: willim.riordan@co.galveston.tx.us

Set # _____

INSTRUCTIONS TO BIDDERS
JERRY J. ESMOND JUVENILE JUSTICE CENTER ROOF REPLACEMENT
GALVESTON COUNTY, TEXAS

The owner invites bids on the form indicated in Section 00 41 13 for the above referenced project.

1. Method of Bidding: The Owner invites the following bid(s):
 - a. BASE BID, ITEM #1: Roof Replacement & Exterior Sealant Replacement
 - b. ALTERNATE BID, ITEM #2: Exterior Elastomeric Coating

2. Time of Completion: Time of completion of this Contract is of importance to the Owner and may be considered in the award of the Contract. The Contractor shall state on his proposal the number of calendar days he will require to complete the project in its entirety. Payments on the Contract will be made as provided by the Contract. No payment will be made on the Contract within 30 days prior to the completion date set by the Contractor, unless there is an extended unforeseen delay, over which the Contractor has no control, such as severe or unseasonable weather, it shall be the Contractor's responsibility to request an extension in time within the above time limit shall void any possible extension of the Contract time of completion. The Owner will be the judge as to whether a time extension is to be granted and so notify the Contractor.

3. Access to building(s):
 - a. During bidding the site will be available by appointment with the Owner's Representative only.
 - b. During construction special care should be taken as the building will be in operation during construction.

4. Hazardous Materials: Do not bid or provide or install hazardous materials or products containing asbestos, polychlorinated biphenyl (PCB), lead in water piping, etc.

5. Pre-Construction Conference: A pre-construction conference will be held two weeks (14 days) prior to the beginning any work on this project. After full execution of the contract and insurance certificate, the Contractor shall contact the Owner and set up a date, time and place to meet on site with the Contractor, his major subcontractors, Owner and Manufacturer. The purpose of this meeting will be to discuss schedules, procedures, special considerations and any other pertinent items related to this project.

6. Buildings in Use: All areas to be reroofed will be in use during construction. Particular care for the safety of the occupants of the building shall be taken while working on site and in the vicinity of the building. Coordinate the work process with the Owner to avoid conflicts and potential hazards.

SECTION 00 52 13 - AGREEMENT FORM

Agreement (Stipulated Price)

The Agreement will be executed on AIA Document Number A-101 "Standard Form of Agreement between Owner and Contractor", Current Edition.

OR

Form as approved by Galveston County.

END OF SECTION 00 52 13

SECTION 00 43 13 - BID SECURITY

Each bid must be accompanied by Bid Security in the amount of five percent (5%) of the largest possible total of the bid submitted. Refer to the General Provisions, Section 38, Page 13.

The Bid Security may be by certified check or a Bid Bond. The Bid Bond must be executed by the bidder as principal. The Bid Bond form and security company are subject to approval by the Owner and the surety must comply with requirements noted in the General Conditions.

The bid security will be returned promptly after the Owner and the accepted bidder have executed the Contract, or, if no award has been made within thirty (30) days after the date of the opening of bids, upon demand of the bidder anytime thereafter so long as he has not been notified of the acceptance of his bid.

END OF SECTION 00 43 13

SECTION 00 61 13 - BONDS AND CERTIFICATES

The Contractor, if required and paid for by owner, shall furnish the following Bonds and Certificates to be delivered simultaneously with the executed Contract:

1. Performance Bond
2. Labor and Materials Payment Bond
3. Certificate of Insurance (Provide on AIA Doc. G-612 or an approved format)

The Performance, Labor and Material Bond shall be provided on Bonds which comply with current civil statutes of the State of Texas.

The Contractor shall furnish a Performance Bond in an amount equal to one hundred percent (100%) of the Contract Sum as security for the faithful performance of this Contract and also a one hundred percent (100%) Labor and Materials Payment Bond, as security for the payment of all persons performing labor on the Project under this Contract and furnishing materials in connection with this Contract. The Performance Bond and Labor and Material Bond may be in one or in separate instruments in accordance with local law and shall be delivered to the Owner not later than the date of execution of the Contract. Surety companies executing Bonds must appear on the U.S. Treasury Department's most current list showing their established maximum risk and be authorized to transact business in the state where the Project is located. Surplus lines carriers are not acceptable. Must be rated A or better by A.M. Best insurance guide.

Cost of above stated bonds and insurance are to be included in the bid.

Attorneys-in-Fact who sign bonds must file each bond a certified and effective dated copy of their Power of Attorney.

The Performance Bond shall guarantee the repair and maintenance of all defects due to faulty materials and workmanship that appear within one year from date of substantial completion.

END OF SECTION 00 61 13

SECTION 00 72 00 - GENERAL CONDITIONS

PART 1 - GENERAL

1.01 DEFINITIONS

- A. The contract documents consist of the Agreement, the General Conditions of the contract, the Supplemental Conditions, the Drawings and the Specifications, including all revisions thereto.
- B. The Owner, the Contractor, and the representatives shall be indicated as such throughout these documents. The term Contractor as used herein shall designate the successful bidder to whom the roof replacement contract for the various work is awarded. The term Owner shall be understood to be Galveston County.

1.02 OWNERS REPRESENTATIVE STATUS

- A. The owner's representative shall have general supervision and direction of the work and are the agents of the Owner in all matters pertaining to the work as provided in the Contract Documents. They have authority to stop the work whenever such stoppage may be necessary to insure the proper execution of the contract and shall have authority to reject any and all materials, whether worked or unworked, if such materials are not in accordance with the plans and specifications.

1.03 PERMITS AND LICENSES

- A. All permits and licenses of a temporary nature necessary to the lawful prosecution of the work shall be secured and paid for by the Contractor.

1.04 CONDITIONS OF THE SITE

- A. The bidders shall visit the site before submitting their bids and determine the field conditions affecting their work. In considering the bids the owner will assume that the bidders are aware of all items pertinent to their work and have made allowance for same in their bids.

1.05 VERIFICATION OF DIMENSIONS AND ELEVATIONS

- A. Dimensions and elevations indicated on the drawings in reference to existing structures or utilities are the best available data obtainable but are not guaranteed by the owner and the owner will not be responsible for their accuracy. Before proceeding with any work dependent upon the data involved, the Contractor shall field check and verify all dimensions, grades, lines, levels, or other conditions of limitations at the site to avoid construction errors. If any work is performed by the Contractor, or any of his sub-contractors prior to adequate verification or applicable data, any resultant extra cost for adjustment of work, as required to conform to existing limitations, shall be assumed by the Contractor without reimbursement or compensation by the Owner.

1.06 SUPERINTENDENT

- A. The Contractor shall keep a competent superintendent, satisfactory to the Owner, on the job at all times when work is in progress. The superintendent shall not be changed without notifying the owner unless the superintendent ceases to be in the employment of the Contractor.
- B. The superintendent shall represent the Contractor in his absence and all directions and instructions given to the superintendent shall be as binding as if given directly to the Contractor.

- C. The superintendent shall be responsible for the conduct of all the Contractor's employees on the premises and shall promptly take necessary measures to correct any abuses called to his attention by the Owner.

1.07 CONTINUATION OF OWNER'S OPERATIONS

- A. The Contractor shall erect such barriers, tarpaulins, doors, etc. As maybe necessary to protect the Owner's operations while work is in progress. Any such openings that are essential to carrying on the work shall be securely closed by the Contractor when not in use to protect the Owner's operations. A completion date will be established at the preconstruction meeting.

1.08 PROTECTION OF WORK AND PROPERTY

- A. The Contractor shall maintain adequate protection of all his work from damage and shall protect the Owner's and adjacent property from injury or loss arising from this contract. He shall provide and maintain at all times any danger signs, guards and/or obstructions necessary to protect the public and his workmen from any dangers inherent with or created by the work in progress. He shall hold the Owner harmless from any loss arising due to injury or accident to the public or his workmen, or from theft of materials stored at the job site. All materials will be stored in locations other than on roof surfaces except as necessary and shall then be placed on plywood or other type material to protect roof surfaces at all times.
- B. Before starting any work protect all grounds, copings, paving and the exterior of all building surfaces where work will be performed.
- C. In those areas where materials and/or hot asphalt will be raised to the roof area a protective covering shall be placed from the base of the wall extending up and over the top edge of the roof. This covering shall be wide enough to assure that the exterior walls do not become stained or soiled during roofing operations.
- D. Any areas of the building or grounds which have become stained or damaged in any way shall be repaired or replaced prior to the final inspection. The method of repair used must be acceptable to both the Owner and the Owner's Consultant.
- E. At no time will any equipment, materials or any other items be set on or stored on a new complete roofing section.

1.09 MATERIAL STORAGE AND CLEANUP

- A. The contractor shall keep the premises free from rubbish at all times and shall arrange his material storage so as not to interfere with the Owner's operations. At the completion of the job, all the unused material and rubbish shall be removed from the site. The ground shall be raked clean and the building shall be broom cleaned. If the Contractor refuses at any time to remove his debris from the premises, or to keep the working area clean, such cleaning will be completed by the Owner and charged to the Contractor.
- B. The Contractor shall also remove drippage of bitumen or adhesive from all walls, window, floors, ladders and finished surfaces. Failure to do so when asked by the Owner will result in the work being done and charged to the Contractor

1.10 INSPECTION OF WORK

- A. If the drawings or specifications require the inspection and approval of any work or process by the owner, the Contractor shall give the owner ample notice to allow for scheduling the inspection, which shall be made promptly to avoid delay of work. If any work should be covered up by the Contractor without required inspection or approval by the owner it shall be uncovered at the Contractor's expense.

- B. Uncovering of work not originally inspected, or uncovering of questioned work may be ordered by the owner and it shall be done by the Contractor. If examination proves such work to be incorrectly done or not done in accordance with the plans and specifications, the Contractor shall bear all cost of the examination. If the work is proven correctly installed, all such expense shall be borne by the Owner.

1.11 INSPECTION OF WORK IN PROGRESS AND UPON COMPLETION

- A. As directed by the Owner's Representative, the contractor shall cut not more than 1 core, of approximately 144 square inches each, from every newly constructed built-up roof area, in order to establish the amount of materials used per square foot, and shall restore all such areas to sound and watertight conditions.
- B. In the event that such core cuts disclose any deficiency in materials, or soundness of construction, the contractor shall, at his own expense, apply additional materials or other wise correct the deficiencies to the satisfaction of the Owner's Representative.
- C. Non-compliance with the terms of this specification and ensuing contract can result in either the cancellation of the contract, or complete replacement of the defective areas at the Contractor's expense. In the event of cancellation, the Owner will not be obligated to compensate the Contractor for any work undertaken in a defective manner. The Contractor understands that no materials containing asbestos will be used on this project.
- D. Furthermore, damages caused by water infiltration resulting from the failure of the contractor to secure each day's work in a weather tight manner, will be corrected at the contractor's expense. Included as damages will be all labor costs incurred by the Owner as a result of such water infiltration.
- E. The Owner will authorize the Owner's representative to periodically examine the work in progress, as well as upon completion, in order to ascertain the extent to which the materials and procedures conform to the requirements of these specifications and to the current published instructions of the Manufacturer.
- F. The manufacturer's field representative or consultant shall be responsible for:
 - 1. Keeping the Owner's Representative informed on a periodic basis as to the progress and quality of the work.
 - 2. Calling to the attention of the contractor those matters, which he considers to be in violation of the contract requirements.
 - 3. Reporting to the Owner's Representative any failure or refusal of the Contractor to correct unacceptable practices.
 - 4. Conducting preliminary and subsequent job site meetings with the contractor's official job representatives.
 - 5. Supervising the taking of test cuts, and the restoration of such areas.
 - 6. Rendering any other inspection services which the Owner's Representative may designate.
 - 7. Certifying, after completion of the work, the extent to which the contractor has complied with these specifications as well as to the current published instructions of the Manufacturing Company.
 - 8. Inspections of work in progress.
 - 9. The Manufacturers field representative shall be an full-time employee of the manufacturer, and not a distributor, or agent.
- G. The presence and activities of the manufacturer's field representative or consultant shall in no way relieve the Contractor of his contractual responsibilities.

1.12 SEPARATE CONTRACTS

- A. The Owner reserves the right to do work or to let other contracts in connection with the work. The Contractor shall afford other such contractors a reasonable opportunity to store their material and shall cooperate with them to the best of his ability to expedite the rapid completion of the work.
- B. If any portion of the Contractor's work depends upon the Owner's or other contractor's work, the Contractor shall inspect and approve such work before proceeding with his own. He shall promptly notify the Owner of any defects in such work that will render subsequent work unsuitable. His failure to so inspect and report shall constitute an acceptance of the other contractor's work as fit and proper for the execution of his work, except as for such defects that were not at that time observable and shall subsequently develop.

1.13 MISCELLANEOUS UTILITIES

- A. Electrical power will be furnished by the Owner for small tools only. All connections to the electrical system will be furnished by the Contractor. Any temporary lights necessary to the work shall be furnished by the Roofing contractor.
- B. Water for concrete, mortar, and washing purposes will be furnished by the Owner. Any connections to the water system shall be completed by the Contractor.
- C. At the completion of the work, or when the above connections are no longer required, the Contractor shall remove all connections and leave the facilities in a condition at least as satisfactory as prior to the commencement of his work.
- D. Toilet facilities will be provided by the Contractor. Temporary toilets shall be the responsibility of the Contractor, unless the Owner approves otherwise at the Pre-construction meeting. The Contractors workmen shall gain access to the roof from the exterior only.

1.14 CHANGES OR EXTRA WORK

- A. The Owner may, without invalidating the original contractor, order such changes or additions as may from time to time be deemed desirable. In so doing, the contract price shall be adjusted as stated below with all work being done under the conditions of the original contract except for such adjustments in extension of time as may be acceptable to the owner. The value of such extra work shall be determined in one of the following ways:
 - 1. By firm price adjustment.
 - 2. By cost plus with a guaranteed maximum.
 - 3. By cost with a fixed fee.
 - 4. By unit cost.
- B. If agreement is reached that the extra cost shall be handled as per methods, 2, 3, or 4, the Contractor shall keep and compile a correct amount of the cost together with such vouchers, etc., as may be necessary to substantiate same for presentation to the owner's representatives. The owner's representative shall have authority to make minor job changes or additions as may be necessary to expedite the job providing such changes do not involve material additional cost. No major change or addition shall be made except upon receipt by the Contractor of a signed order from the Owner authorizing such a change. No claims for an extra to the contract price shall be valid unless so authorized.

1.15 CORRECTION OF WORK PRIOR TO FINAL PAYMENT

- A. The Contractor shall promptly remove any work that does not meet the requirements of the plans and specifications or is incorrectly installed or otherwise disapproved by the owner's representative as failing to meet the intention of the plans and specifications. The Contractor shall promptly replace any such work without expense to the Owner and shall bear the cost of

making good all work of other contractors, or the Owner, destroyed or damaged by such removal or replacement.

1.16 CORRECTION OF WORK AFTER FINAL PAYMENT

- A. If the owner's representative deems it inexpedient to have the Contractor correct work which has been incorrectly done, a deduction from the contract price shall be agreed upon therefore. Such a deduction from the contract price shall in no way affect the Contractor's responsibility for defects which may occur, not his ability for correcting them, and damage caused by them, as specified in Article 1.15.

1.17 LIENS

- A. The Contractor shall furnish the Owner a release in full of all liens arising out of this contract. The Contractor shall furnish an affidavit that the liens or receipts include all the labor and material for which a lien could be filed. In lieu of the above, the Contractor may at his option furnish a bond to indemnify the Owner against all hazards of liens. Neither part nor final payment shall in any way release the Contractor from the above obligation and in the event that part or full payment has been made and any lien remains un-discharged, the Contractor shall refund to the Owner necessary funds to discharge such a lien including all cost and attorney's fees.

1.18 JOB CONDITIONS

- A. All surfaces to be covered shall be smooth, dry, and free from dirt, debris, and foreign material before any of this work is installed. Pumping equipment shall be located on the ground at a safe distance from building; the location being subject to the approval of the Owner. The Contractor shall be responsible for guarding against fires, and shall provide suitable fire extinguishers conveniently located at the site.
- B. Competent operators shall be in attendance at all times equipment is in use. Materials shall be stored neatly in areas designated by the Owner and dispersed so as to present a minimum fire hazard. Loads placed on the roof at any point shall not exceed the safe load for which the roof is designed.
- C. There is NO SMOKING allowed inside or outside the building and the Contractor shall be responsible for enforcement of this job rule at all times with his personnel. The Owner shall designate safe places for smoking at the preconstruction meeting.
- D. Under certain conditions it will be necessary and desirable to incorporate one or more of the following methods for removal of dirt, silt, gravel, debris, roof membrane and insulation from the roof surface in order to preserve the ecology, eliminate unsightly conditions and protect building surfaces.
 - 1. Roof vacuum systems.
 - 2. Crane and hopper with dump truck system.
 - 3. Enclosed chutes with protective shrouds on building and ground surfaces and shrubbery.
- E. These contingencies will be specified at the preconstruction conference.
- F. Ladders: When ladders are used on this project they must be in good condition. The ladder must also be secured at the roof line at all times while in use. All ladders must be O.S.H.A. approved.
- G. The Contractor shall place necessary barriers and/or protection around or under all work areas where his/her operations involve risk of injury to plant.

1.19 WORKMANSHIP

- A. All materials will be securely fastened and placed in a watertight, neat and workmanlike manner. All workmen shall be thoroughly experienced in the particular class or work upon which employed. All work shall be done in accordance with these specifications and shall meet the approval in the field of the Owner or his representative. Contractor's representative, job supervisor, shall have a complete copy of specifications and drawings on job site at all times.

1.20 SAFETY

- A. Contractor shall conform to requirements as designated by the United States Federal Government (O.S.H.A.). Contractor shall abide by all regulations as outlined in the O.S.H.A. handbook and shall have a handbook on location at all times.
- B. Contractor and all on-site personnel must undergo Site-Specific Safety Training and shall at all times act in strict accordance with all NRCA recommended safety compliance rules and regulations.

1.21 COLD MATERIALS

- A. All cold materials, including sealants and roofing cements, shall be approved by the owner.

1.22 SUBSTITUTION OF SPECIFIED MATERIALS

- A. Whenever a particular make of material or trade name is shown or specified herein, it shall be regarded as being indicative of the standard required. A Bidder who proposed to quote on the basis of an alternate material or system shall submit to the Owner's representative the following information, at least seven (7) days prior to the scheduled bid opening date. All tests listed in this specification must be performed between the standard system, and the proposed substitute. If any tests are not completed then only the standard system shall be accepted. Refer to Section 01 25 13 Product Substitution Procedures.

1.23 ROOF DECK

- A. Contractor shall notify the Owner of his designate on the job site of any unforeseen areas of defective decking. Where the damage is serious and extensive, it will be the Owner's responsibility to authorize removal and replacement of deteriorated decking. Where damage to the roof deck is found, the Owner shall ask the Roofing Contractor to make the necessary repairs at the unit cost established in the quote.

1.24 INSURANCE

- A. The following standard indemnity agreement and minimum insurance requirements are incorporated in the Specifications for all work performed by Contractors for the Owner, its affiliated and associated organizations or subsidiaries, hereinafter referred to as Owner.
- B. The Contractor agrees to indemnify and save the Owner harmless from and against any and all costs, loss and expense, liability damages, or claims for damages, including cost for defending any action, on account of any injury to persons (including death) or damage to or destruction of property of the Owner, arising or resulting from the work provided for or performed, or from any act, omission, or negligence of the Contractor, Sub-contractor and his or their agents or employees. The foregoing provisions shall in no way be deemed released, waived or modified in any respect by reason of any insurance or surety provided by the Contractor.
- C. If any work provided for or to be performed under any specifications is sub-let (as otherwise permitted by the terms of such specifications), the Contractor shall require the sub-contractors

to maintain and furnish him with satisfactory evidence Workmen's Compensation, Employers' Liability and such other forms and amounts of insurance which Contractor deems reasonably adequate.

- D. In accordance with Item II, the Contractor shall maintain the following insurance:
1. Workmen's Compensation and Employer's Liability Insurance affording, (a) protection under the Workmen's Compensation Law of the States in which the work is performed, and (b) Employer's Liability protection subject to a minimum limit of \$100,000.
 2. Comprehensive General Liability Insurance in amounts not less than \$2,000,000.00.
 - a. Bodily Injury: \$500,000 Each Occurrence; \$500,000 Annual Aggregate.
 - b. Property Damage: \$500,000 Each Occurrence; \$500,000 Annual Aggregate.
 3. Contractual Liability:
 - a. Bodily Injury: \$500,000 Each Occurrence; \$500,000 Annual Aggregate.
 - b. Property Damage: \$500,000 Each Occurrence; \$500,000 Annual Aggregate.
 4. Personal Injury, with employment exclusion deleted:
 - a. \$1,000,000 Annual Aggregate.
 - b. This insurance shall:
 - 1) Include coverage for the liability assumed by the Contractor under Item I (Indemnity);
 - 2) Include completed operation coverage which is to be kept in force by the Contractor for a period of not less than one year after completion of the work provided for or performed under these specifications;
 - 3) Not be subject to any of the special property damage liability exclusions commonly referred to as the XCU exclusions pertaining to blasting or explosion, collapse or structural damage and underground property;
 - 4) Not be subject to any exclusion of property used by the insured or property in the case, custody or control of the insured or property as to which the insured for any purpose is exercising physical control; and the Certificates of Insurance furnished by the contractor shall show by specific reference that each of the foregoing items have been provided for.
 5. Comprehensive Automobile Liability Insurance in the following minimum amounts:
 - a. Bodily Injury: \$250,000 per person; \$500,000 per accident.
 - b. Property Damage: \$250,000 per accident.
- E. The Certificates of Insurance furnished by the Contractor as evidence of the Insurance maintained by him shall include a clause obligating the Insurer to give the owner thirty (30) days prior written notice for cancellation of any material change in the insurance.

1.25 SAFETY AND ECOLOGY

- A. Contractor shall conform to requirements as designated by the United States Federal Government (OSHA) and or other applicable safety codes or regulations.

1.26 ANTI-DISCRIMINATION IN EMPLOYEMNT

- A. Contractors and Subcontractors shall not discriminate against any employees or applicant for employment, to be employed in performance of his contract, with respect to his hire, tenure, terms, conditions or privileges of employment because of his race, color, religion, national origin, or ancestry.

1.27 RESPONSIBILITY FOR MEASUREMENTS AND QUANTITIES

- A. The Bidding Contractors shall be solely responsible for the accuracy of all measurements and for estimating the material quantities required to satisfy these specifications.

1.28 PRE-JOB MEETING

- A. A pre-job meeting shall be held prior to the start of this project. This meeting shall include the Contractor and the Owner's representative. The condition of the buildings and related grounds areas shall be recorded and the contractor shall be responsible for the correction and/or repair of any additional damage to the facilities resulting from the related work and in addition to the conditions noted at the pre-job meeting.

1.29 DISCREPANCIES AND ADDENDA

- A. Should a Bidder and any discrepancies in the Drawings and Specifications, or should he be in doubt as to their meaning, he shall notify the Owner at once, who will send a written Addendum to all Bidders concerned. Oral instructions or decisions, unless confirmed by Addendum, will not be considered valid, or legal or binding.
- B. No extra will be authorized because of failure of the Contractor to include work called for in the Addenda in his bid.

1.30 COMPETENCY OF THE BIDDER

- A. To enable the Owner to evaluate the competency and financial responsibility of Contractor, the low Bidder shall, when requested by the Owner, furnish the following information which shall be sworn to under oath by him or by a properly authorized representative of the Bidder:
 - 1. The address and description of the Bidder's plant and place of business.
 - 2. The name and/or Articles of co-partnership or incorporation.
 - 3. Itemized list of equipment available for use on the project.
 - 4. A certified or authenticated financial statements, dated within sixty (60) days prior to the openings of the bids. The Owner may require that any items of such statements be further verified.
 - 5. A list of present contracts, including dollar values, percentage of completion and the names of all owners involved.
 - 6. A statement regarding any past, present or pending litigation with an Owner.
 - 7. Such additional information as may be required that will satisfy the Owner that the Bidder is adequately prepared in technical experience, or otherwise to fulfill the Contract.
 - 8. Sufficient documents to ensure that the Contractor is in compliance with the current Fair Employment Practice requirements of the Owner.

1.31 DISQUALIFICATION OD BIDDERS

- A. Any one or more of the following causes may be considered sufficient for the disqualification of a bidder and the rejection of his bid or bids:
 - 1. Failure to attend the mandatory pre-bid meeting.
 - 2. Evidence of collusion among bidders.
 - 3. Lack of responsibility as revealed by either financial, experience or equipment statements, as submitted.
 - 4. Lack of expertise as shown by past work, and judged from the standpoint of workmanship and performance history.
 - 5. Uncompleted work under other contracts which, in the judgment of the Owner, might hinder or prevent the prompt completion of additional work if awarded.
 - 6. Being in arrears on existing contracts, in litigation with an Owner, or having defaulted on a previous contract.
 - 7. Failure to comply with the submittals section of the specification.
 - 8. Contractor not operating under the same name or ownership for a minimum of five years.

1.32 PAYMENT

- A. At least ten days before the date established for each progress payment, the Contractor shall submit to the Owner an itemized Application for Payment for operations completed in accordance with the schedule of values. Prior to this submittal, the Contractor shall contact the Owner's Representative for on-site review of the proposed application. Upon approval by the Owners Representative, the Application for Payment shall be submitted to the Owner. Included shall be the data required to support the Contract's right to payment as may be required by the Owner, such as copies of requisitions from subcontractors and material suppliers, and reflecting retainage, if provided for elsewhere in the Contract Documents.
- B. Contract shall submit application in duplicate using AIA Document G702, Application and Certificate for Payment, May 1983 Edition. All blanks in the form must be completed and signature of Contractor and Notary Public must be original on each form.
- C. Progress Payments: Based upon Applications for Payment submitted to the Owner by the Contractor, the Owner shall make progress payments on account of the Contract Sum to the Contractor as provided in the Conditions of the Contract as follow:
 - 1. On or about the fifteenth (15th) day of each month ninety percent (90%) of the proportion of the Contractor Sum properly allocable to labor, materials and equipment incorporated in the Work and ninety percent (90%) of the portion of the Contract Sum properly allocable to materials and equipment suitably stored at the site or at some other location agreed upon in writing by the parties, up to the first (1st) day of that month; less the aggregate of previous payments in each case; and upon Substantial Completion of the entire work, a sum sufficient to increase the total entire work, a sum sufficient to increase the total payments to ninety percent (90%) of the Contract Sum less such retainage as the Owner's Representative shall determine for all incomplete work and unsettled claims.
- D. Final Completion and Final Payment: Prior to final payment, the Contractor shall submit in duplicate to the Owner the following completed forms:
 - 1. Contractors Affidavit of Release of Liens, AIA Document G706A.
 - 2. Consent of Surety to Final Payment, AIA G707.
 - 3. Contractor's Guarantee.
 - 4. Manufacturer' Guarantee.

PART 2 - PRODUCTS – Not applicable to this section.

PART 3 - EXECUTION – Not applicable to this section.

END OF SECTION 00 72 00

SECTION 00 73 43 - WAGE RATE REQUIREMENTS

PART 1 - GENERAL

1.01 REQUIREMENTS

- A. Pay not less than the minimum wage scale and benefits accepted within the local Construction industry.
- B. No claims for additional compensation will be considered by the Owner because of payments of wage rates in excess of the applicable rate contained in this contract.
- C. All Contractors and subcontractors shall be equal opportunity employers

1.02 APPLICABLE STATUTES

- A. Vernon's Civil Statutes, Section 2 of Article 5159a which states as follows:
 - 1. "The Contractor shall forfeit as a penalty to the State, County, City, Town, District or other political subdivision on whose behalf the Contract is made or awarded, Sixty dollars (\$60.00) for each laborer, workman or mechanic, for each working day, or portion thereof, such laborer, workman or mechanic is paid less than the said stipulated rates for any work done under said Contract, by him, or by any subcontractor under him, and the public body awarding the Contract shall cause to be inserted in the Contract a stipulation to this effect."

1.03 PAYROLL

- A. In compliance with Article 515a, Section 2 and 3, and Article 515d, Section II of the Revised Civil Statute referenced above, the Owner reserves the following rights:
 - 1. To receive weekly payroll records.
 - 2. To have the Contractor provide required earning statements to employees.

1.04 PREVAILING WAGE RATES

- A. Pay prevailing basic wage listed, plus any applicable fringe benefits.
- B. In no case shall wages be less than those set forth in the current published federal prevailing wage scale.

1.05 PREVAILING WAGE SCALE NOTICE

- A. This determination of prevailing wages shall not be construed to prohibit the payment of more than the rates named. Under no condition shall any laborer, workman or mechanic employed on this job be paid less than the minimum wage scale.
- B. In execution of this contract, the contractor must comply with all applicable state and federal laws, including but not limited to laws concerned with labor, equal employment opportunity, safety, and minimum wage. Contractor shall verify current prevailing wage scale.
- C. Basic Rates:
 - 1. Apprentice Pay - All Trades and Crafts
 - a. The minimum rate for apprentices shall be in accordance with the scale determined by approved apprenticeship program or \$1.00 per hour less than journeymen's rates, whichever is lower. An approved apprenticeship program is one approved by the U.S. Department of Labor, Bureau of Apprenticeship Training, and only apprentices enrolled in an approved program may be paid apprenticeship rate.
 - 2. Base per Diem Rate: (Hours Worked/Day) X (Base Hourly Rate)
 - 3. Multipliers for Overtime Rates:
 - a. Over 40 hours per week: Base hourly rate times 1.5

b. Holidays: Base hourly rate times 1.5

PART 2 - PRODUCTS – Not applicable to this section.

PART 3 - EXECUTION – Not applicable to this section.

END OF SECTION 00 73 43

"General Decision Number: TX20200248 01/03/2020

Superseded General Decision Number: TX20190248

State: Texas

Construction Type: Building

County: Galveston County in Texas.

BUILDING CONSTRUCTION PROJECTS (does not include single family homes or apartments up to and including 4 stories).

Note: Under Executive Order (EO) 13658, an hourly minimum wage of \$10.80 for calendar year 2020 applies to all contracts subject to the Davis-Bacon Act for which the contract is awarded (and any solicitation was issued) on or after January 1, 2015. If this contract is covered by the EO, the contractor must pay all workers in any classification listed on this wage determination at least \$10.80 per hour (or the applicable wage rate listed on this wage determination, if it is higher) for all hours spent performing on the contract in calendar year 2020. If this contract is covered by the EO and a classification considered necessary for performance of work on the contract does not appear on this wage determination, the contractor must pay workers in that classification at least the wage rate determined through the conformance process set forth in 29 CFR 5.5(a)(1)(ii) (or the EO minimum wage rate, if it is higher than the conformed wage rate). The EO minimum wage rate will be adjusted annually. Please note that this EO applies to the above-mentioned types of contracts entered into by the federal government that are subject to the Davis-Bacon Act itself, but it does not apply to contracts subject only to the Davis-Bacon Related Acts, including those set forth at 29 CFR 5.1(a)(2)-(60). Additional information on contractor requirements and worker protections under the EO is available at www.dol.gov/whd/govcontracts.

Modification Number Publication Date
0 01/03/2020

ASBE0022-009 06/01/2019

Rates Fringes

ASBESTOS WORKER/HEAT & FROST
INSULATOR (Duct, Pipe and
Mechanical System Insulation)....\$ 24.28 14.16

BOIL0074-003 01/01/2017

Rates Fringes

BOILERMAKER.....\$ 28.00 22.35

CARP0551-011 04/01/2016

Rates Fringes

CARPENTER (Excludes
Acoustical Ceiling
Installation, Drywall
Finishing/Taping, Drywall
Hanging, Form Work and Metal
Stud Installation).....\$ 23.05 8.78

* ELEC0527-002 10/28/2019

Rates Fringes

ELECTRICIAN (Excludes Low
Voltage Wiring and
Installation of Alarms).....\$ 29.43 3% + 10.65

ELEV0031-003 01/01/2019

Rates Fringes

ELEVATOR MECHANIC.....\$ 42.60 33.705

FOOTNOTES:

A. 6% under 5 years based on regular hourly rate for all
hours worked. 8% over 5 years based on regular hourly rate

for all hours worked.

B. Holidays: New Year's Day; Memorial Day; Independence Day;
Labor Day; Thanksgiving Day; Friday after Thanksgiving Day;
Christmas Day; and Veterans Day.

ENGI0450-002 04/01/2014

| | Rates | Fringes |
|--------------------------|----------|---------|
| POWER EQUIPMENT OPERATOR | | |
| Cranes..... | \$ 34.85 | 9.85 |

IRON0084-011 06/01/2019

| | Rates | Fringes |
|-----------------------------|----------|---------|
| IRONWORKER, ORNAMENTAL..... | \$ 24.42 | 7.12 |

PAIN0130-002 06/01/2018

| | Rates | Fringes |
|---|----------|---------|
| PAINTER (Brush, Roller, and Drywall Finishing/Taping)..... | \$ 17.88 | 9.50 |

PLAS0079-004 01/01/2015

| | Rates | Fringes |
|----------------|----------|---------|
| PLASTERER..... | \$ 19.92 | 1.00 |

* PLUM0068-002 10/01/2019

| | Rates | Fringes |
|--------------|----------|---------|
| PLUMBER..... | \$ 36.15 | 11.04 |

PLUM0211-010 10/01/2018

| | Rates | Fringes |
|---|----------|---------|
| PIPEFITTER (Including HVAC Pipe Installation)..... | \$ 33.30 | 12.26 |

SHEE0054-012 07/01/2017

Rates Fringes

SHEET METAL WORKER

Excludes HVAC Duct and

Unit Installation.....\$ 27.72 13.70

HVAC Duct Installation Only.\$ 27.72 13.70

SUTX2014-024 07/21/2014

Rates Fringes

ACOUSTICAL CEILING MECHANIC.....\$ 16.41 3.98

BRICKLAYER.....\$ 19.86 0.00

CAULKER.....\$ 15.36 0.00

CEMENT MASON/CONCRETE FINISHER...\$ 13.82 0.00

DRYWALL HANGER AND METAL STUD
INSTALLER.....\$ 17.88 5.24

ELECTRICIAN (Alarm
Installation Only).....\$ 17.97 3.37

ELECTRICIAN (Low Voltage
Wiring Only).....\$ 19.23 3.55

FLOOR LAYER: Carpet.....\$ 20.00 0.00

FORM WORKER.....\$ 12.07 0.00

GLAZIER.....\$ 17.09 3.41

HVAC MECHANIC (Installation
of HVAC Unit Only).....\$ 17.40 0.00

IRONWORKER, REINFORCING.....\$ 12.10 0.00

IRONWORKER, STRUCTURAL.....\$ 25.37 6.00

LABORER: Common or General.....\$ 11.47 0.00

LABORER: Mason Tender - Brick...\$ 13.37 0.00

| | | |
|--|----------|------|
| LABORER: Mason Tender - Cement/Concrete..... | \$ 10.50 | 0.00 |
| LABORER: Pipelayer..... | \$ 12.94 | 0.00 |
| LABORER: Roof Tearoff..... | \$ 11.28 | 0.00 |
| LABORER: Landscape and Irrigation..... | \$ 9.49 | 0.00 |
| LATHER..... | \$ 20.11 | 0.00 |
| OPERATOR: Backhoe/Excavator/Trackhoe..... | \$ 14.10 | 0.00 |
| OPERATOR: Bobcat/Skid Steer/Skid Loader..... | \$ 13.93 | 0.00 |
| OPERATOR: Bulldozer..... | \$ 20.77 | 0.00 |
| OPERATOR: Drill..... | \$ 16.22 | 0.34 |
| OPERATOR: Forklift..... | \$ 15.64 | 0.00 |
| OPERATOR: Grader/Blade..... | \$ 13.37 | 0.00 |
| OPERATOR: Loader..... | \$ 13.55 | 0.94 |
| OPERATOR: Mechanic..... | \$ 17.52 | 3.33 |
| OPERATOR: Paver (Asphalt, Aggregate, and Concrete)..... | \$ 16.03 | 0.00 |
| OPERATOR: Roller..... | \$ 16.00 | 0.00 |
| PAINTER: Spray (Excludes Drywall Finishing/Taping)..... | \$ 17.43 | 4.43 |
| ROOFER..... | \$ 15.40 | 0.00 |
| SPRINKLER FITTER (Fire Sprinklers)..... | \$ 18.62 | 3.03 |
| TILE FINISHER..... | \$ 12.00 | 0.00 |

| | | |
|---|----------|------|
| TILE SETTER..... | \$ 16.17 | 0.00 |
| TRUCK DRIVER: 1/Single Axle Truck..... | \$ 14.95 | 5.23 |
| TRUCK DRIVER: Dump Truck..... | \$ 12.39 | 1.18 |
| TRUCK DRIVER: Flatbed Truck..... | \$ 19.65 | 8.57 |
| TRUCK DRIVER: Semi-Trailer Truck..... | \$ 12.50 | 0.00 |
| TRUCK DRIVER: Water Truck..... | \$ 12.00 | 4.11 |
| WATERPROOFER..... | \$ 14.39 | 0.00 |

WELDERS - Receive rate prescribed for craft performing operation to which welding is incidental.

=====

Note: Executive Order (EO) 13706, Establishing Paid Sick Leave for Federal Contractors applies to all contracts subject to the Davis-Bacon Act for which the contract is awarded (and any solicitation was issued) on or after January 1, 2017. If this contract is covered by the EO, the contractor must provide employees with 1 hour of paid sick leave for every 30 hours they work, up to 56 hours of paid sick leave each year. Employees must be permitted to use paid sick leave for their own illness, injury or other health-related needs, including preventive care; to assist a family member (or person who is like family to the employee) who is ill, injured, or has other health-related needs, including preventive care; or for reasons resulting from, or to assist a family member (or person who is like family to the employee) who is a victim of, domestic violence, sexual assault, or stalking. Additional information on contractor requirements and worker protections under the EO is available at www.dol.gov/whd/govcontracts.

Unlisted classifications needed for work not included within the scope of the classifications listed may be added after award only as provided in the labor standards contract clauses (29CFR 5.5 (a) (1) (ii)).

The body of each wage determination lists the classification and wage rates that have been found to be prevailing for the cited type(s) of construction in the area covered by the wage determination. The classifications are listed in alphabetical order of ""identifiers"" that indicate whether the particular rate is a union rate (current union negotiated rate for local), a survey rate (weighted average rate) or a union average rate (weighted union average rate).

Union Rate Identifiers

A four letter classification abbreviation identifier enclosed in dotted lines beginning with characters other than ""SU"" or ""UAVG"" denotes that the union classification and rate were prevailing for that classification in the survey. Example: PLUM0198-005 07/01/2014. PLUM is an abbreviation identifier of the union which prevailed in the survey for this classification, which in this example would be Plumbers. 0198 indicates the local union number or district council number where applicable, i.e., Plumbers Local 0198. The next number, 005 in the example, is an internal number used in processing the wage determination. 07/01/2014 is the effective date of the most current negotiated rate, which in this example is July 1, 2014.

Union prevailing wage rates are updated to reflect all rate changes in the collective bargaining agreement (CBA) governing this classification and rate.

Survey Rate Identifiers

Classifications listed under the ""SU"" identifier indicate that no one rate prevailed for this classification in the survey and the published rate is derived by computing a weighted average rate based on all the rates reported in the survey for that classification. As this weighted average rate includes all rates reported in the survey, it may include both union and non-union rates. Example: SULA2012-007 5/13/2014. SU indicates the rates are survey rates based on a weighted average calculation of rates and are not majority rates. LA indicates the State of Louisiana. 2012 is the year of survey on which these classifications and rates are based. The next number, 007 in the example, is an internal number used in producing the

wage determination. 5/13/2014 indicates the survey completion date for the classifications and rates under that identifier.

Survey wage rates are not updated and remain in effect until a new survey is conducted.

Union Average Rate Identifiers

Classification(s) listed under the UAVG identifier indicate that no single majority rate prevailed for those classifications; however, 100% of the data reported for the classifications was union data. EXAMPLE: UAVG-OH-0010 08/29/2014. UAVG indicates that the rate is a weighted union average rate. OH indicates the state. The next number, 0010 in the example, is an internal number used in producing the wage determination. 08/29/2014 indicates the survey completion date for the classifications and rates under that identifier.

A UAVG rate will be updated once a year, usually in January of each year, to reflect a weighted average of the current negotiated/CBA rate of the union locals from which the rate is based.

WAGE DETERMINATION APPEALS PROCESS

1.) Has there been an initial decision in the matter? This can be:

- * an existing published wage determination
- * a survey underlying a wage determination
- * a Wage and Hour Division letter setting forth a position on a wage determination matter
- * a conformance (additional classification and rate) ruling

On survey related matters, initial contact, including requests for summaries of surveys, should be with the Wage and Hour Regional Office for the area in which the survey was conducted because those Regional Offices have responsibility for the Davis-Bacon survey program. If the response from this initial contact is not satisfactory, then the process described in 2.) and 3.) should be followed.

With regard to any other matter not yet ripe for the formal process described here, initial contact should be with the Branch of Construction Wage Determinations. Write to:

Branch of Construction Wage Determinations
Wage and Hour Division
U.S. Department of Labor
200 Constitution Avenue, N.W.
Washington, DC 20210

2.) If the answer to the question in 1.) is yes, then an interested party (those affected by the action) can request review and reconsideration from the Wage and Hour Administrator (See 29 CFR Part 1.8 and 29 CFR Part 7). Write to:

Wage and Hour Administrator
U.S. Department of Labor
200 Constitution Avenue, N.W.
Washington, DC 20210

The request should be accompanied by a full statement of the interested party's position and by any information (wage payment data, project description, area practice material, etc.) that the requestor considers relevant to the issue.

3.) If the decision of the Administrator is not favorable, an interested party may appeal directly to the Administrative Review Board (formerly the Wage Appeals Board). Write to:

Administrative Review Board
U.S. Department of Labor
200 Constitution Avenue, N.W.
Washington, DC 20210

4.) All decisions by the Administrative Review Board are final.

=====

END OF GENERAL DECISION

"

SECTION 00 41 13 - BID FORM

PROJECT: Juvenile Justice Center Roof Replacement & Waterproofing

PLACE: Galveston County: Juvenile Justice Center
6101 Attwater Ave.
Texas City, TX 77590

DATE: February 6, 2020, 2:00 p.m.

TO: Galveston County Purchasing Department
722 Moody Avenue – 5th Floor
Galveston, TX 77550

1. Pursuant to and in compliance with the Invitation to Bid and the proposed Contract Documents dated October 28, 2019, relating to the above referenced project, the undersigned, hereby proposes and agrees to fully perform the work within the time stated and in strict accordance with the proposed Contract Documents, and Addenda thereto, for the following sum of money:

a. BASE BID, ITEM #1 (ROOF REPLACEMENT & EXTERIOR SEALANTS):

All labor, materials, services, and equipment necessary for completion of the work shown on the drawings and in the Specifications as Bid Item #1.

_____ DOLLARS(\$ _____)
(Amount in Words Governs)

b. ALTERNATE BID, ITEM #2 (EXTERIOR ELASTOMERIC COATING):

All labor, materials, services, and equipment necessary for completion of the work shown on the drawings and in the Specifications as Bid Item #2.

_____ DOLLARS(\$ _____)
(Amount in Words Governs)

2. The Bidder attests to and affirms that he and his subcontractors are skilled and experienced in the use and interpretation of plans, specifications, addenda and related Bid Documents and, that he has carefully reviewed the plans, specifications, addenda and related Bid Documents for this project and has found them to be free of conflicts and/or ambiguities and sufficient for bidding and construction purposes. Further, he has carefully examined the soils reports and the site of the work, and, through his own person observations, has satisfied himself as to the nature, location and requirements of the work; the character, quality and quantity of materials required; the difficulties likely to be encountered; the other items and/or conditions which may affect the satisfactory performance of the work. He has based his bid solely on these documents, and personal observations, and has not relied in any way on any explanation or interpretation, oral or written, from any source other than those written and issued by the Owner.

3. UNIT PRICES: The undersigned agrees, in case of variation of quantities from those shown or specified, the following unit prices will be used in adjusting the Contract price. If additional quantities are authorized in advance by the Owner. The following amount will be added to the Contract:

a. Cost per 100 sq ft Lightweight Insulating Concrete Repair \$ _____

b. Cost per board foot wood nailer \$ _____

4. If awarded this Contract the undersigned will execute a satisfactory Construction Contract and proof of insurance coverage, with the Owner for the entire work as per the Contract Documents within 10 days after notice of award. It is agreed that this proposal is subject to the Owners acceptance for a period of thirty (30) days from the above date.
5. The undersigned agrees to the following:
- a. To furnish all labor and materials as shown and specified.
 - b. To complete Bid Item #1 in _____ calendar days.
 - c. To complete Bid Item #2 in _____ calendar days.
 - d. To work _____ working days per week.
 - e. To begin work _____ days after notice of award of contract.

6. Receipt is acknowledged of the following addenda:

| | |
|-----------|-------------|
| No. _____ | Dated _____ |
| No. _____ | Dated _____ |
| No. _____ | Dated _____ |
| No. _____ | Dated _____ |

7. The Bidder attests to and affirms that he and his subcontractors are skilled and experienced in the use and interpretation of plans, specifications, addenda and related Bid Documents and, that he has carefully reviewed the plans, specifications, addenda and related Bid Documents for this project and has found them to be free of conflicts and/or ambiguities and sufficient for bidding and construction purposes. Further, he has carefully examined the soils reports and the site of the work, and, through his own person observations, has satisfied himself as to the nature, location and requirements of the work; the character, quality and quantity of materials required; the difficulties likely to be encountered; the other items and/or conditions which may affect the satisfactory performance of the work. He has based his bid solely on these documents, and personal observations, and has not relied in any way on any explanation or interpretation, oral or written, from any source other than those written and issued by the Owner.

Bidder agrees that the Owner has the right to accept or reject any or all bids and to waive all informalities.

Respectfully Submitted,

By: _____
(Signature)

Date _____, 20 _____

(Printed Name)

(Title)

(Company)

SECTION 00 41 13 - BID FORM

PROJECT: Juvenile Justice Center Roof Replacement & Waterproofing

APPROVED APPLICATOR LETTER

TO: Galveston County

RE: Juvenile Justice Center Roof Replacement & Waterproofing

This letter of approval is to certify that _____ Roofing Contractor/Waterproofer, is currently an approved applicator of _____ Roofing & Waterproofing Systems, and is authorized to install our Roofing/Waterproofing System on the Galveston County Roof Replacement & Waterproofing project.

MANUFACTURER: _____

BY: _____

SIGNATURE _____

TITLE: _____

DATE: _____

THIS FORM MUST BE ATTACHED TO BID PROPOSAL WHEN SUBMITTED.

SECTION 00 41 13 - BID FORM

PROJECT: Juvenile Justice Center Roof Replacement & Waterproofing

MANUFACTURER'S WARRANTY AND INSPECTION LETTER

The undersigned Roofing System Manufacturer acknowledges that they have inspected the job site for Galveston County Juvenile Justice Center Roof Replacement & Waterproofing; read the specifications in their entirety; that they approve the installation of their roofing system as specified over the existing substrate conditions; and will provide a 30 year "No Dollar Limit" leak free warranty as specified in Section 07 52 16 of the Specifications.

The undersigned also agrees that the Manufacturer will provide at no charge to the Owner, job-site inspections a minimum of three days per week during construction; and provide, at the annual request of the Owner, annual inspections for the duration of the warranty period as specified in Section 07 52 16 of the Specifications. These inspections shall only be carried out by full-time employees of the Manufacturer.

I, _____, certify that I am the
_____ Of the below named Corporation.
(Corporate Officer's Title)

(Name of Roofing System Manufacturer)

By: _____

Date: _____

(Affix Corporate Seal)

THIS FORM MUST BE ATTACHED TO BID PROPOSAL WHEN SUBMITTED

SECTION 01 11 00 - SUMMARY OF WORK

PART 1 - GENERAL

1.01 SUMMARY

- A. Project Identification: Juvenile Justice Center Roof Replacement and Waterproofing project for Galveston County located in Texas City, TX.
- B. Project Summary: Roofing Contractor shall act as Prime Contractor in re-roofing and waterproofing the above referenced facility as indicated in the General Conditions, Specifications, and Drawings.

1.02 SCOPE OF WORK

- A. Low-Slope Modified Bitumen Roof Replacement
 1. Coordinate with Galveston County personnel to set up job-site in strict accordance with Owner's guidelines and OSHA requirements.
 2. Completely remove existing roof system and all sheet metal and flashing components down to the lightweight insulating concrete deck.
 3. Mechanically attach new Type II base sheet in strict accordance with roof system manufacturer's ASCE 7-10 wind uplift engineering calculations and fastening patterns.
 4. Heat fuse base ply of smooth-surfaced, Type II torch-grade modified bitumen to the prepared substrate, in shingled fashion starting at the drains and working outward to the high points of the lightweight insulating concrete deck.
 5. Heat fuse cap ply of reflective mineral-surfaced, Type III torch-grade modified bitumen to the prepared substrate, in shingled fashion starting at the drains and working outward.
 6. Immediately broadcast new roofing granules in to the bleed-out at all side and end laps of cap ply.
 7. Strip all lead flashings in beneath the cap sheet with one ply of smooth-surfaced, Type II torch-grade modified bitumen.
 8. Fabricate and install new, 24-gauge stainless steel perimeter edge system with 22-gauge continuous cleat in strict accordance with ANSI/SPRI ES-1 guidelines.
 9. Heat fuse new- 2-ply hybrid modified bitumen base flashings as indicated in the specifications and drawings and coat with two coats of reflective acrylic flashing coating.
- B. Exterior Envelope Waterproofing
 1. Remove existing building sealant from joints and clean/prep to receive new sealants.
 2. Prime surfaces to receive new joint sealants.
 3. Install new backer rod and sealants in accordance with manufacturer's written instructions.
 4. At all windows, thoroughly clean and prepare window frames at existing glazing.
 5. Re-glaze all windows with new back, silicone sealant.
- C. Exterior Envelope Coating (ALTERNATE)
 1. Pressure wash entire exterior of building in preparation for new elastomeric coating.
 2. Apply two coats of new elastomeric acrylic coating (color selected by Owner) to the building envelope.

1.03 PROJECT REQUIREMENTS

- A. Existing site conditions and restrictions: The building will be occupied at the time of construction and care must be taken not to disturb normal operations of the occupants. A man must be staged on ground at all times.

- B. Texas Windstorm Insurance: The roofing contractor will be responsible for contracting with a T.W.I.A. certified Texas registered professional engineer to inspect the project to ensure strict compliance with all current wind uplift requirements and filing the required forms with the state to be in compliance and registered with the T.W.I.A. for windstorm coverage
- C. Roof Material Edge Protection: Precaution shall be taken to ensure that no materials, debris or tools are able to fall from the roof at any point.
- D. Permits: Apply for, obtain, and pay for permits required to perform the work. Submit copies to Owner.
- E. Codes: Comply with applicable codes and regulations of authorities having jurisdiction. Submit copies of inspection reports, notices and similar communications to Owner.
- F. Dimensions: Verify dimensions and quantities indicated in scope of work with field dimensions before fabrication or ordering of materials.
- G. Existing Conditions: Notify owner's representative or consultant of existing conditions differ from those indicated in the scope of work. Do not remove or alter structural components without prior written approval.
- H. Definition for terms used in the Specifications:
 - 1. Provide: Furnish and install, complete with all necessary accessories, ready for intended use. Pay for all related costs.
 - 2. Approved: Acceptance of item submitted for approval. Not a limitation or release for compliance with the Contract Documents or regulatory requirements. Refer to limitations of "Approved" in General and Supplementary Conditions.
 - 3. Match Existing: Match existing as acceptable to the Owner.
 - 4. Intent: Specifications are intended to provide the basis for proper completion of the work suitable for the intended use of the Owner. Anything not expressly set forth but which is reasonable implied or necessary for proper performance of the project shall be included.
 - 5. Writing Style: Specifications are written in the imperative mode. Except where specifically intended otherwise, the subject of all imperative statements is the Contractor. For example, "Provide tile" means Contractor shall provide tile.

PART 2 - PRODUCTS – Not applicable to this section.

PART 3 - EXECUTION – Not applicable to this section.

END OF SECTION 01 11 00

SECTION 01 33 00 - SUBMITTAL PROCEDURES

PART 1 - GENERAL

1.01 SUMMARY

- A. Comply with project format for submittals.
- B. Provide types of submittals listed in individual sections and number of copies required.
 - 1. Shop drawing, reviewed and annotated by the Contractor (two prints).
 - 2. Product data (two copies).
 - 3. Samples (two), plus extra samples as required to indicate range of color, finish, and texture to be expected.
 - 4. Warranties (two copies).
- C. Provide required re-submittals if original submittals are not approved. Provide distribution of approved copies including modifications after submittals have been approved.
- D. Samples and shop drawings shall be prepared specifically for this project. Shop drawings shall include dimensions and details, including adjacent construction and related work. Note special coordination required. Note any deviations from requirements of the Contract Documents.
- E. Provide warranties as specified in Section 07 52 16.12 Modified Bitumen Roofing. Owner requires single source responsibility for all roof assemblies. Multiple manufacturers are not acceptable.

PART 2 - PRODUCTS - Not applicable to this section.

PART 3 - EXECUTION - Not applicable to this section.

END OF SECTION 01 33 00

SECTION 01 50 00 - TEMPORARY FACILITIES

PART 1 - GENERAL

1.01 SUMMARY

- A. Provide temporary services and utilities, including utility costs:
 - 1. Telephone. (As required)
 - 2. Toilet facilities.
 - 3. Material storage.

- B. Provide security and protection requirements:
 - 1. Fire extinguisher.
 - 2. Site enclosure barricades.
 - 3. Environmental protection.

- C. Provide personnel support facilities:
 - 1. Sanitary facilities.
 - 2. Drinking water.
 - 3. Cleaning and trash removal.

PART 2 - PRODUCTS - Not applicable to this section.

PART 3 - EXECUTION - Not applicable to this section.

END OF SECTION 01 50 00

SECTION 01 62 00 - PRODUCT OPTIONS

PART 1 - GENERAL

1.01 PRODUCT LIST

- A. Within 14 days after date of Contract, submit to the Owner complete list of all products which are proposed for installation.
 - 1. Tabulate list by each specification section.
- B. For products specified under Reference Standards, include with listing of each product:
 - 1. Name and Address of Manufacturer.
 - 2. Trade Name.
 - 3. Manufacturer's Data.
 - 4. Model or Catalog Designation.

1.02 CONTRACTORS OPTIONS

- A. For products specified only by Reference Standards, select any product meeting standards, by any manufacturer.
- B. For products specified by naming several products or manufacturers, select any product and manufacturer named.
- C. For products specified by naming one or more products, but indicating the option of selecting equivalent products e.g., by stating "or pre-approved substitution" after specified product, Contractor must submit request as required for substitution, for any product not specifically named.
- D. For products specified by naming only one manufacturer, contractor shall use only the manufacturer and product as specified.

1.03 SUBSTITUTION

- A. During bidding, the Owner will consider only written request from prime bidders for substitutions that don't meet these performance requirements or make up, received at least 7 days prior to bid date; request received after that time will not be considered. In the event a substitution is accepted, all bidders shall be notified of the acceptable alternate within three (3) days prior to bid date. Requests for substitution shall include five (5) copies of:
 - 1. Complete data substantiating compliance of proposed substitution with Contract Documents.
 - 2. For products: Substitutions will only be considered if submitted by a prime bidder who attends the mandatory pre-bid conference.
 - a. Product identification, including manufacturer's literature, manufacture's name, address and location of manufacturing facility or facilities.
 - b. Current certificate from an accredited testing laboratory comparing the physical and performance attributes of the proposed material with those of the specified.
 - c. Any material submitted as equal to the specified material must be accompanied by a report signed and sealed by a professional engineer licensed in the state in which the installation is to take place. This report shall show that the submitted equal meets the Design and Performance criteria in this specification. Substitution requests submitted without licensed engineer approval will be rejected for non-conformance.
 - d. Specimen Warranty: Provide an unexecuted copy of the warranty specified for this Project, identifying the terms and conditions required of the Manufacturer and the Owner.

- e. List of at least five (5) local jobs, where the proposed alternate material was used under similar conditions. These jobs must be available for inspection by the Owner. Names and phone numbers are required for verification.
 - 3. For construction methods:
 - a. Detailed description of proposed method.
 - b. Drawings illustrating methods.
 - 4. Itemized comparison of proposed substitution with product or method specified.
 - 5. Data related to changes in construction schedule.
 - 6. Relation to separate contracts.
- B. In making request for substitution, Bidder/Contractor represents:
- 1. He has personally investigated proposed product or method, and determined that it is equal or superior in all respects to that specified.
 - 2. He will provide the same guarantee for substitution as for product or method specified.
 - 3. He will coordinate installation of accepted substitution in work, making such changes as may be required for work to be completed in all respects.
 - 4. He waives all claims for additional cost related to substitution that consequently becomes apparent.
 - 5. Cost data is complete and includes all related cost under his contract or other contracts, which may be affected by the substitution.
 - 6. He will reimburse the Owner for all redesign cost substitute may require.
- C. Substitution will not be considered if:
- 1. Product or method to be considered does not have a minimum of fifteen (15) years of successful performance in the United States.
 - 2. Any discrepancies in the test data, or if the tests or submittals are incomplete.
 - 3. They are indicated or implied on Shop Drawings or Project Data Submittals without formal request submitted in accordance with Article 1.3, Paragraph A of this specification section.
- D. Acceptance will require substitution revision of Contract Documents.

PART 2 - PRODUCTS – Not applicable to this section.

PART 3 - EXECUTION – Not applicable to this section.

END OF SECTION 01 62 00

SECTION 06 10 00 - ROUGH CARPENTRY

PART 1 - GENERAL

1.01 SUMMARY

- A. Scope of Work:
 - 1. Provide all labor, equipment, and materials to install wood, nails, bolts, framing anchors, rough hardware and other items needed for rough Carpentry in this work and as shown in the drawings.
 - 2. Replace any damaged or rotten wood nailers as required.
 - 3. Install new treated wood blocking at perimeter roof edge to accommodate new insulation height.
- B. Related Sections:
 - 1. Section 07 01 50.19 "Preparation for Re-Roofing".
 - 2. Section 07 52 16.12 "Modified Bituminous Membrane Roofing".
 - 3. Section 07 62 00 "Sheet Metal Flashing and Trim".

1.02 DELIVERY AND STORAGE

- A. Time delivery and installation of carpentry work to avoid delaying other trades whose work is dependent on or affected by the carpentry work. Keep materials dry during delivery.
- B. Store lumber and plywood in stacks with provisions for air circulation within stacks. Protect bottom of stacks against contact with damp or wet surfaces.
- C. Protect exposed materials against water and wind. Remove damaged or unsuitable material from the job site.

1.03 QUALITY ASSURANCE

- A. Comply with governing codes and regulations. Use experienced installers.
- B. Lumber Standards: American Softwood Lumber Standards PS 20-70 by U.S. Department of Commerce.
- C. Plywood Standards: U.S. Product Standard PSI-74/ANSI A 199.1 or latest APA Performance Standards for American Plywood Association.
- D. Factory Marking: Mark each piece of lumber or plywood to indicate type, grade, agency providing inspection service.
- E. Size and Shape: Dress lumber 4 sides (S4S) and work to shapes and patterns shown. Nominal sizes shown and specified refer to undressed lumber dimensions. Detailed dimensions do not show actual lumber size required.

PART 2 - PRODUCTS

2.01 MATERIALS

- A. Construction Lumber: Standard Grade Douglass Fir, Western Larch, Western Hemlock (WWPA or WCLB) or No. 2 dimension Southern Pine (SPIB).
- B. Exterior Type Plywood: APA rated sheathing, EXT.
- C. Bucks, Nailers, Blocking, Curb, Etc. Pressure treated with water-borne preservatives to comply with AWPB LP-2. After treatment kiln-dry lumber and plywood to a maximum moisture content, respectively, of 19% to 15%.
- D. Anchorage and Fastening: Proper type, size material and finish for each application.

- E. Quality: Sound, seasoned, well manufactured materials of longest practical lengths and sizes in minimize joining. Free from warp which cannot be easily corrected by anchoring and attachment. Discard material with defects which would impair quality of work.

PART 3 - EXECUTION

3.01 EXAMINATION

- A. Verify measurements and dimensions as shown before proceeding with carpentry work.
- B. Examine supporting structure and conditions under which carpentry work is to be installed. Do not proceed with installation until unsatisfactory conditions have been corrected.
- C. Correlate location of nailers, blocking and similar supports for attached work.
- D. Scribe and cope as required for accurate fit of carpentry work to other work.

3.02 PROTECTION

- A. Protect installed work from damage by other trades until acceptance of work.

3.03 INSTALLATION

- A. Provide decking, nailers, blocking, curbs, and sleepers where shown on the drawings or required for attachment of other work. Coordinate with location with other work involved; refer to shop drawings of such work.
- B. Attach to substrate securely as required to support applied loading. Countersink bolts and nuts flush with surfaces.
- C. Securely attach wood nailers to substrate in accordance with Factory Mutual Loss Prevention Data Sheet I-49 and as required by recognized standards.
- D. Provide washers under bolt heads and nuts in contact with wood.
- E. Do not wax or lubricate fasteners that depend on friction for holding power.
- F. Select fasteners of size that will not penetrate members where opposite side will be exposed to view or will receive finish material.
- G. Make tight connections between members. Install fasteners without splitting of wood; pre-drill as required. Do not drive threaded friction type fasteners; turn into place. Tighten bolts and lag screws at installation and re-tighten as required for tight connections prior to closing in or at completion of work.

END OF SECTION 06 10 00

SECTION 01 77 00 - CLOSEOUT PROCEDURES

PART 1 - GENERAL

1.01 SUMMARY

- A. The following are pre-requisites to substantial completion. Provide the following:
 - 1. Punch list.
 - 2. Supporting documentation.
 - 3. Certification.
- B. Final payment request with supporting affidavits.
 - 1. Final payment request with supporting affidavits.
 - 2. Completed punch list.
 - 3. Warranties.
 - 4. Final release of liens.
 - 5. Release of surety.
- C. Provide a marked-up set of drawings including changes which occurred during construction.
- D. Provide the following closeout procedures:
 - 1. Submission of record documents.
 - 2. Submission of maintenance manuals.
 - 3. Final cleaning and touch up.
 - 4. Removal of temporary facilities.

PART 2 - PRODUCTS - Not applicable to this section.

PART 3 - EXECUTION - Not applicable to this section.

END OF SECTION 01 77 00

SECTION 01 73 29 - CUTTING AND PATCHING

PART 1 - GENERAL

1.01 SUMMARY

- A. Provide cutting and patching work to properly complete the work of the project, complying with requirements for.
 - 1. Visual requirements, including detailing and tolerances.
 - 2. Inspection, preparation, and performance.
 - 3. Cleaning.
- B. Do not cut and patch in a manner that would result in a failure of the work to perform as intended, decreased energy performance, increased maintenance, decreased operational life, or decreased safety.

PART 2 - PRODUCTS

2.01 MATERIALS

- A. Match existing materials for cutting and patching work with new materials conforming to protect requirements.

PART 3 - EXECUTION

3.01 INSTALLATION

- A. Inspect conditions prior to work to identify scope and type of work required. Protect adjacent work. Notify Owner of work requiring interruption to building services or Owner's operations.
- B. Perform work with workmen skilled in the trades involved. Prepare sample area of each type of work for approval.
- C. Cutting: Use cutting tools, not chopping tools. Make neat holes. Minimize damage to adjacent work. Check for concealed utilities and structure before cutting.
- D. Patching: Make patches, seams, and joints durable and inconspicuous. Comply with tolerance for new work
- E. Clean work area and areas affected by cutting and patching operations

END OF SECTION 01 73 29

SECTION 07 01 50.19 - PREPARATION FOR RE-ROOFING

PART 1 - GENERAL

1.01 SUMMARY

- A. Scope of Work:
 - 1. Remove existing roofing membrane and sheet metal accessories.
 - 2. Quantify and repair any damaged or deficient concrete decking.
 - 3. Install new mechanically attached base sheet.
- B. Related Sections:
 - 1. Section 06 10 00 "Rough Carpentry".
 - 2. Section 07 52 16.12 "Modified Bituminous Membrane Roofing".
 - 3. Section 07 62 00 "Sheet Metal Flashing and Trim".

1.02 PRE-INSTALLATION CONFERENCE

- A. Attend conference specified in Section 07 52 16.12 "Modified Bituminous Membrane Roofing".
- B. Review installation procedures and coordination required with related work.

1.03 SUBMITTALS

- A. Submit product data and samples of materials to be used.
- B. Submit Roof System Manufacturer's project-specific wind uplift calculations with base sheet fastening patterns.

1.04 ENVIRONMENTAL REQUIREMENTS

- A. Do not remove roofing existing roofing panels or decking when weather conditions threaten the integrity of the building contents or intended continued occupancy. Maintain continuous temporary protection prior to new roofing system

1.05 PROTECTION

- A. Roofing Contractor is to be responsible for all mechanical, electrical and plumbing services required for the removal and re-installation of the new roof system.
- B. During execution or work covered by these specifications, the Contractor shall provide protection for equipment, materials, and personnel inside and outside the building against falling debris, sparks, and water.
- C. It shall be the Contractor's responsibility to respond immediately to correction of roof leakage during construction. A 4-hour time limit shall be given from the time of notification of emergency conditions. In the event of water penetration during rain or storm, the Contractor shall provide for repair or protection of building contents and interior. If the Contractor does not respond or cannot be contacted, the Owner will affect repairs or emergency action and the Contractor shall be back charged for all expenses and damages, if any.

1.06 SCHEDULING

- A. Schedule work to coincide with commencement of installation of new insulation and roofing system.

PART 2 - PRODUCTS

2.01 MATERIALS

- A. Temporary Protection: Sheet polyethylene. Provide weights to retain sheeting in position.
- B. Asphalt Primer: As specified in Section 07 52 16.12 "Modified Bituminous Membrane Roofing".
- C. Nailable Base Sheet:
 - 1. ASTM D-5147 Type II, SBS Modified polyester/fiberglass/polyester reinforced base sheet. HPR Tri-base Premium or by The Garland Co., Inc. pre-approved equal.
- D. Base Sheet Fasteners: Split-shank fastener, designed and suitable for fastening to Lightweight Insulating Concrete Deck Systems, FM-90 by ES Products.
- E. Lightweight Repair Material: Zono-Patch by Siplast or pre-approved equal.

PART 3 - EXECUTION

3.01 EXAMINATION

- A. Verify all existing site conditions prior to proceeding with work specified in this Section.
- B. Verify that existing roof surface is clear and ready for work of this Section.
- C. Verify that work and operations related to this project, performed by others, is complete prior to proceeding with work specified in this Section.

3.02 MATERIAL REMOVAL

- A. Remove all membrane, insulation, cant strips, base flashings and items shown on the drawings. Ensure the complete removal of all nails to leave a smooth even surface for re-roofing.
- B. Under certain conditions it will be necessary and desirable to incorporate one or more of the following methods for removal of dirt, silt, gravel, debris, roof membrane and insulation from the roof surface in order to preserve the ecology, eliminate unsightly conditions and protect building:
 - 1. Roof vacuum system.
 - 2. Crane and hopper with dump truck system.
 - 3. Enclosed chutes with protective shrouds on building and ground surfaces.
- C. All debris dumped from the roof shall be transported from the roof via chutes into dumpsters or trucks, and this debris shall be removed from the premises when vehicles are full. No debris shall be transported from the area being worked over an existing finished roof without and underlayment of 3/4" plywood.
- D. All roof equipment not in use or left filled will be parked on the column lines on 3/4" plywood.
- E. Contractor shall provide tie-ins at the end of each days work. Prime existing roof surface prior to making tie-ins.

3.03 BASE SHEET INSTALLATION

- A. Prior to attachment of the base sheet, contractor shall verify that the deck surface is free of any dirt, debris or irregularities.
- B. Mechanically attach the base sheet with specified fasteners, in a shingled fashion, starting at the drains in strict accordance with roof system manufacturer's wind uplift guidelines and project-specific fastening patterns.

3.04 TEMPORARY PROTECTION

- A. Provide temporary protective sheeting over uncovered deck surface.
- B. Retain sheeting in position with weights or temporary fasteners.
- C. Provide for surface drainage from sheeting to existing drainage facilities.
- D. Do not permit traffic over unprotected or repaired deck surface

END OF SECTION 07 01 50.19

SECTION 07 62 00 - SHEET METAL FLASHING AND TRIM

PART 1 - GENERAL

1.01 RELATED DOCUMENTS

- A. Drawings and general provisions of the Contract, including General and Supplementary Conditions and Division 01 Specification Sections, apply to this Section.

1.02 SUMMARY

- A. This Section includes the following:
 - 1. Roof penetration sleeves and bonnets.
 - 2. Receivers.
 - 3. Counter flashings.
 - 4. Sanitary vent pipes.
 - 5. Curb cap flashings.
 - 6. Exhaust vents.
 - 7. Copings.
 - 8. Dip edge.
 - 9. Gutters and downspouts.
 - 10. Miscellaneous sheet metal accessories.
- B. Related Sections include the following:
 - 1. Section 06 10 00 "Rough Carpentry"
 - 2. Section 07 01 50.19 "Preparation for Re-Roofing".
 - 3. Section 07 52 16.12 "Modified Bituminous Membrane Roofing".

1.03 REFERENCES

- A. American Society for Testing and Materials (ASTM).
- B. Federal Specifications (FS).
- C. National Roofing Contractor's Association (NRCA): NRCA Roofing and Waterproofing Manual, latest edition.
- D. Sheet Metal and Air Conditioning Contractor's National Association, Inc. (SMACNA): Architectural Sheet Metal Manual, latest edition.
- E. ANSI/SPRI ES-1 Wind Design Standard for Edge Systems Used with Low Slope Roofing Systems.

1.04 WARRANTY

- A. Contractor's Warranty: Provide Owner a written warranty which shall warrant sheet metal work to be free of leaks and defects in materials and workmanship for two years after date of final acceptance by owner.
- B. For pre-finished metal, provide manufacturer's twenty-year guarantee covering deterioration or failure of the flouropolymer finish.

1.05 PERFORMANCE REQUIREMENTS

- A. Fabricate and install sheet metal edge flashings to comply with ANSI/SPRI ES-1 requirements.

PART 2 - PRODUCTS

2.01 MANUFACTURERS

- A. Acceptable pre-finished Sheet Metal Manufacturer's:
 - 1. The Garland Co., Inc.
 - 2. Or pre-approved equal.

2.02 SHEET METAL MATERIAL

- A. Pre-finished Metal: "Kynar 500" or "Hylar 5000" fluoropolymer pre-finished aluminum, minimum 0.050". "Kynar 500" or "Hylar 5000" finish shall consist of a two-coat Polyvinyladine fluoride, minimum 70 percent by weight in coatings, dry film thickness 1 mil, factory applied by metal manufacturer or supplier. Color to be selected by Owner and Architect from manufacturer's standard color chart.
- B. Zinc-coated (Galvanized) Sheet Metal: Commercial Quality with 0.20 percent copper, in accordance with ASTM A 526 except ASTM A 527 for lock forming; coating designation G() hot-dip galvanized, and mill phosphatized for painting in accordance with ASTM A 525 (paint-grip type), 22 gauge minimum.
- C. Sheet Lead: FS QQ-L-201, Grade B; 2-1/2 pounds per square foot, 0.0391-inches thick minimum used for sanitary vent flashing.
- D. Stainless Steel Sheet Metal: ASTM A240, Type 304, ASTM A480, No. 2B/2D Mill Finish, gauge as scheduled.

2.03 FASTENERS

- A. Fasteners shall be same metal as flashing and sheet metal being joined.
- B. Exposed fasteners shall be self-sealing or gasketed for weathertight installation.
- C. Heads of fasteners, including but not limited to, rivets, screws, and bolts, that are exposed or visible shall have same manufactured finishes as item being secured; color to match when applicable.
- D. Mechanical Fasteners:
 - 1. Washers: Steel washers with bonded rubber sealing gasket.
 - 2. Screws: Self-tapping sheet metal type compatible with material fastened.
 - 3. Rivets: Stainless steel material for the stem with closed end, head of color to match sheet metal items being joined.

2.04 RELATED MATERIALS

- A. Solder:
 - 1. ASTM B 32, alloy grade 58, 50 percent tin, 50 percent lead.
 - 2. For use with stainless steel: 60-40 tin/lead solder, ASTM B 32.
- B. Flux:
 - 1. Phosphoric acid type, manufacturer's standard.
 - 2. For use with steel or copper: Rosin flux.
 - 3. For use with stainless steel: Acid-chloride type flux, except use rosin flux over tinned surfaces.
- C. Underlayment: Elastomeric self-adhering sheeting suitable for high-temperature; minimum 30 mil thickness: "WIP 300HT" by Carlisle or pre-approved equal.

- D. Adhesives: Type recommended by flashing sheet manufacturer for waterproof and weather resistant seaming and adhesive application of flashing sheet.
- E. Metal Accessories: Sheet metal clips, straps, anchoring devices, and similar accessory units as required for installation of work, matching or compatible with material being installed, non-corrosive, size and gauge required for performance.
- F. Sealant: As recommended by the manufacturer.
- G. Termination Bar: 1/8-inch thick, 1-inch wide extruded aluminum bar with flat profile, factory punched holes spaced 6-inches on center.

2.05 FABRICATION, GENERAL

- A. Fabricate work in accordance with SMACNA Architectural Sheet Metal Manual and other recognized industry practices and approved shop drawings.
- B. Comply with material manufacturer's instructions and recommendations for forming material.
- C. Shop fabricate work to the greatest extent possible.
- D. Fabricate for waterproof and weather resistant performance with expansion provisions for running work sufficient to permanently prevent leakage, damage, or deterioration of work. Form work to fit substrates.
- E. Make angle bends and folds for interlocking metal with full regard for expansion and contraction to avoid buckling.
- F. Form materials with straight lines, sharp angles, smooth curves and true levels. Avoid tool marks, buckling, and oil canning.
- G. Fold back edges of exposed ends of sheet metal edge to form hem, 1/2-inch minimum.
- H. Lap joints 1-inch minimum. Rivet and solder joints on parts that are to be permanently and rigidly assembled for stainless steel sheet metal. Install rivets, spaced 1-inch on center and apply solder to secure and seal exposed edge of sheet metal in a uniform continuous bead with smooth top finish. Clean residue upon completion of soldering process. Fabricate sheet metal assemblies so that adjoining sections are nested to achieve continuous metal-to-metal contact.
- I. Seams:
 - 1. Fabricate non-moving seams in sheet metal with flat-lock seams.
 - 2. Pre-finished Galvanized Sheet Metal: Seal pre-finished metal seams with rivets, spaced 1-inch on center, and sealant.

2.06 FABRICATED ITEMS

- A. Receivers and Counter Flashings: Minimum 24-gauge stainless steel sheet metal formed in maximum 10-foot lengths.
- B. Wind Clips: Minimum 24 gauge stainless steel sheet metal, 1-inch wide, length to engage counter flashing a minimum of 1/2-inch.
- C. Roof Penetration Flashing Pan and Bonnet: Minimum 24 gauge stainless steel sheet metal. Fabricate pan with 1/4-inch hem at top edge, 4-inch wide horizontal flanges; to provide installed minimum clear inside perimeter dimension of 2-inches and 6-inch height. Fabricate bonnet in two-piece adjustable construction with 1/2-inch caulk through along top edge and a skirt, with hemmed edge; length to extend over top edge of pan a minimum of 2-inches.
- D. Cleats/Clips: Continuous strips, 22 gauge sheet metal, same metal type and profile as adjacent metal trim.

- E. Sanitary/Plumbing vent Pipe: 2-1/2 pound lead pre-formed flashing sleeve with 4-inch flanges and of proper size/height to fold down inside of vent pipe a minimum of 1-inch.
- F. Pipe Box (Base, Hood and Face Plate): 24 gauge stainless steel sheet metal. Base shall be 8-inches in height with 4-inch wide horizontal flanges. Size to provide minimum 2-inch clearance between box and pipes.
- G. Heat Exhaust/Gravity Vent/Turbine Vent: 24 gauge stainless steel sheet metal. Base shall be 8-inches in height with 4-inch wide horizontal flanges. Hood to conceal top of base.
- H. Coping: 24 gauge stainless steel sheet metal with 6-inch wide cover plates of same material/profile.
- I. Drip Edge: 24 gauge stainless steel sheet metal with 6-inch wide cover plates of same material/profile.

PART 3 - EXECUTION

3.01 EXAMINATION

- A. Verify that substrates are smooth and clean to extent needed for sheet metal work.
- B. Verify that reglets, nails, cants, and blocking to receive sheet metal are installed and free of debris.
- C. Do not start sheet metal work until conditions are satisfactory.

3.02 INSTALLATION

- A. Install sheet metal with lines, arises, and angles sharp and true, and plane surfaces free from objectionable wave, warp, or buckle. Exposed edges of sheet metal shall be folded back to form 1/4-inch hem on concealed side from view. Finished work shall be free from water retention and leakage under all weather conditions. Install prefabricated corners or transitions at changes in direction, elevation or plane, and at intersections. Locate field joints not less than 12-inches, not more than 3 feet from actual corner. Laps for all metals, except for prefinished metal, shall be 1-inch wide, fastened with rivets spaced 1-inch on-center and soldered.
- B. Anchor units of work securely in place to prevent damage or distortion from wind or buckling. Provide for thermal expansion of metal units; conceal fasteners where possible; and set units true to line and level as indicated. Install work with laps, joints, and seams permanently watertight and weatherproof.
- C. Install fabricated sheet metal items in accordance with manufacturer's installation instructions and recommendations and with SMACNA Architectural Sheet Metal Manual.
- D. Prime all flanged sheet metal and allow to dry completely. Set in a liberal bed of SBS modified mastic and strip in to achieve a full finished two plies of SBS modified roofing membrane.
- E. Separations: Provide for separation of metal from non-compatible metal or corrosive substrates by coating affected surfaces with zinc chromate or other permanent liquid-applied or sheet product separation at locations of contact.
- F. Continuous Cleat: At exposed edges of metal edge flashings, fascias, copings, and where required, attach continuous cleat at 6-inches on-center with appropriate fasteners metal or steel substrate. At a distance of 10 feet from each direction of corner, install fasteners spaced 3-inches on-center. Install cleat so fascia extends a minimum of 1-inch below top of exterior wall finish.
- G. Counter flashings:

1. Install counter flashings under equipment housing flanges and receivers along rise or parapet walls to extend a minimum of 4-inches below top edge of base flashing.
2. Secure counter flashing at 6-inches on-center with self-tapping screws.
3. Saw-cut reglet mounted assemblies: Saw cut new joint, 1/2-inch X 1-inch deep, in masonry/concrete where required and to install new receiver. Clean and prepare joint surfaces to receive sealant and insert receiver into joint. Secure new receiver in place with lead wedges spaced 12-inches on-center wedged into joint. Install backer rod into saw-cut reglet and apply a continuous bead of sealant along reglet and top edge of receiver and tool sealant to provide outward sloping finished surface. Secure counter flashing to receiver utilizing self-tapping grommetted screws spaced 6-inches on-center.
4. Surface-mounted assemblies: Secure 2-piece surface-mounted receiver and counter flashing assemblies along substrates. Install sealant tape between receiver and substrate. Secure receiver to substrate with termination bar and appropriate fasteners spaced 12-inches o.c. Install a continuous bead of sealant along caulk trough/top edge of receiver and tool sealant to provide outward sloping finished surface. Secure counter flashing to receiver utilizing grommetted self-tapping screws spaced 6-inches on-center.
5. Install receivers extending behind wall finish and secure vertical flange of receiver 6-inches on-center to back-up wall or metal wall panels. Extend underlayment and/or dampproofing material over vertical flange of receiver, where applicable.
6. Lap adjacent sections of receivers and counter flashings a minimum of 4-inches. Apply a continuous bead of sealant in lap.
7. Secure counter flashing to equipment flanges utilizing self-tapping screws spaced 6-inches on-center.
8. Install wind clips to termination bar spaced 24-inches on-center and engage drip edge of counter flashing a minimum of 1/2-inch.
9. Fabricate the counter flashing to form an integral closure at terminations.

H. Penetration Pans:

1. Install compressible fill insulation between penetrating element and deck.
2. Prime tops and bottoms of flanges of penetration pans.
3. Pop rivet and fully solder joints in pan and flanges.
4. Install penetration pan with flanges set in a uniform troweling of modified bitumen mastic on SBS membrane base ply, secure flange with appropriate fasteners spaced 6-inches on-center, staggered, and strip-in flanges.
5. Fill penetration pan to within 1-inch (25mm) of top of pan with non-shrink grout. Clean surfaces of pan and penetrating element and fill remainder of pan with pourable sealer.
6. Install sheet metal bonnet or hood to conceal the top of the penetration pan.

I. Roof Penetration Hoods and Bonnet:

1. Install sheet metal hood or bonnet on penetrating element to cover the top of the penetration pans.
2. Round or Pipe Penetrations:
 - a. Set bonnet in sealant.
 - b. Install stainless steel draw-band and tighten to secure to penetration.
 - c. Seal top of bonnet with sealant.
3. Square Penetration:
 - a. Secure bonnet to penetration with termination bar and self-drilling screws.
 - b. Set bonnet in sealant.
 - c. Seal top of bonnet with sealant.
4. Angle or Structural Steel Penetration:
 - a. Attach bonnet to structural steel member by welding.
 - b. Paint assembly after installation.

J. Pipe Box:

1. Pop rivet and fully solder joints and seams in sheet metal base and hood.
 2. Prime top and bottom of flanges of base.
 3. Install penetration pan with flanges set in a uniform troweling of modified bitumen mastic on SBS membrane base ply, secure flange with appropriate fasteners spaced 6-inches on-center, staggered, and strip-in flanges.
 4. Fill base with grout or spray foam to a height of 3/4 of the total pan height.
 5. Fill remaining height of base with pourable sealer.
 6. Install hood over base, securing to each side with self-tapping screws, and sloping down toward front of box.
 7. Install face plate to cover box opening around pipe penetrations and apply sealant around pipe configuration at face plate.
- K. Sanitary/Plumbing Vent Pipes:
1. Prime top and bottom flanges of lead flashing sleeve. Set flange or embed in uniform troweling of modified bitumen mastic on SBS membrane base ply. Prime top side of flange to receive strip-in membrane.
 2. Fold lead sleeve down inside pipe a minimum of 1-inch. Apply a continuous bead of sealant on inside of pipe prior to folding lead sleeve. Paint exposed lead flashing with elastomeric coating to match color of membrane top ply.
- L. Heat Exhaust/Gravity Vent/Turbine Vent/Goose-neck Vent:
1. Prime top and bottom of flanges of base.
 2. Install penetration pan with flanges set in a uniform troweling of modified bitumen mastic on SBS membrane base ply, secure flange with appropriate fasteners spaced 6-inches on-center, staggered, and strip-in flanges.
 3. At heat exhaust vents, install sheet metal bonnet secured to vent pipe with stainless steel draw band and apply sealant along top edge of bonnet and tool sealant to provide outward sloping finished surface.

3.03 CLEANING

- A. Remove flux and residual acid immediately by neutralizing with baking soda and washing with clean water. Leave work clean and free of stains, scrap, and debris.
- B. Clean exposed metal surfaces, removing substances which might cause corrosion of metal or deterioration/damage of finishes. Paint (color to match) areas of prefinished metal where finish is damaged. Replace sheet metal items when damaged finish can not be repaired to an acceptable condition.
- C. Prime soldered area of phosphatized metal after cleaning to prevent rusting.

END OF SECTION 07 62 00

SECTION 07 52 16.12 - MODIFIED BITUMINOUS MEMBRANE ROOFING

PART 1 - GENERAL

1.01 RELATED DOCUMENTS

- A. Drawings and general provisions of the Contract, including General and Supplementary Conditions and Division 01 Specification Sections, apply to this Section.

1.02 SUMMARY

- A. This Section includes the following:
 - 1. Work includes all labor, materials, equipment and services necessary for installation of torch-applied SBS modified bituminous membrane roofing system.
- B. Related Sections include the following:
 - 1. Section 06 10 00 "Rough Carpentry"
 - 2. Section 07 01 50.19 "Preparation for Re-Roofing".
 - 3. Section 07 62 00 "Sheet Metal Flashing and Trim".

1.03 REFERENCES

- A. American Society of Civil Engineers (ASCE):
 - 1. ASCE 7-05, Minimum Design Loads for Buildings and Other Structures.
- B. American Society for Testing and Materials (ASTM):
 - 1. ASTM D41 Standard Specification for Asphalt Primer Used in Roofing, Damp Proofing and Waterproofing.
 - 2. ASTM D312 Standard Specification for Asphalt Used in Roofing.
 - 3. ASTM D451 Standard Test Method for Sieve Analysis of Granular Mineral Surfacing for Asphalt Roofing Products.
 - 4. ASTM D1079 Standard Terminology Relating to Roofing, Waterproofing and Bituminous Materials.
 - 5. ASTM D1227 Standard Specification for Emulsified Asphalt used as a Protective Coating for Roofing.
 - 6. ASTM D1863 Standard Specification for Mineral Aggregate used as a Protective Coating for Roofing.
 - 7. ASTM D2178 Standard Specification for Asphalt Glass Felt used as a Protective Coating for Roofing.
 - 8. ASTM D2822 Standard Specification for Asphalt Roofing Cement.
 - 9. ASTM D2824 Standard Specification for Aluminum-pigmented Asphalt Roof Coating.
 - 10. ASTM D4601 Standard Specification for Asphalt Coated Glass Fiber Base Sheet used in Roofing.
 - 11. ASTM D5147 Standard Test Method for Sampling and Testing Modified Bituminous Sheet Materials.
 - 12. ASTM D6162 Standard Specification for Styrene Butadiene Styrene (SBS) Modified Bituminous Sheet Materials using a combination of Polyester and Glass Fiber Reinforcements.
 - 13. ASTM D6163 Standard Specification for Styrene Butadiene Styrene (SBS) Modified Bituminous Sheet Materials using Glass Fiber Reinforcements.
 - 14. ASTM E108 Standard Test Methods for Fire Test of Roof Coverings.
- C. Factory Mutual Research (FM):
 - 1. Roof Assembly Classifications.
- D. National Roofing Contractors Association (NRCA):
 - 1. Roofing and Waterproofing Manual.

- E. Underwriters Laboratories, Inc. (UL):
 - 1. Fire Hazard Classifications.
- F. Warnock Hersey (WH):
 - 1. Fire Hazard Classifications.

1.04 ADMINISTRATIVE REQUIREMENTS

- A. Pre-installation Meeting: Conduct at Project Site.
 - 1. Meet with Owner, Architect, Owner's insurer if applicable, testing and inspecting agency representative, roofing Installer, roofing system manufacturer's representative, deck Installer, and installers whose work interfaces with or affects roofing, including installers of roof accessories and roof-mounted equipment.
 - 2. Review methods and procedures related to roofing installation, including set up and mobilization areas for stored material and work area.
 - 3. Review safety procedures and site-specific requirements relating to the work and areas to be accessed.
 - 4. Review and finalize construction schedule, and verify availability of materials, Installer's personnel, equipment, and facilities needed to make progress and avoid delays.
 - 5. Examine deck substrate conditions and finishes for compliance with requirements, including flatness and fastening.
 - 6. Review structural loading limitations of roof deck during and after roofing.
 - 7. Review base flashings, special roofing details, roof drainage, roof penetrations, equipment curbs, and condition of other construction that affects roofing system.
 - 8. Review governing regulations and requirements for insurance and certificates if applicable.
 - 9. Review temporary protection requirements for roofing system during and after installation.
 - 10. Review roof observation and repair procedures after roofing installation.
 - 11. Review notification procedures for weather or non-working days.

1.05 QUALITY ASSURANCE

- A. Manufacturer Qualifications: Company specializing in manufacturing the products specified in this Section with not less than 15 years documented experience and have ISO 9001 certification.
- B. Installer Qualifications: Company specializing in modified bituminous roofing installation with not less than 5 years experience and authorized by roofing system manufacturer as qualified to install manufacturer's roofing materials.
- C. Installer's Field Supervision: Maintain a full-time Supervisor/Foreman on job site during all phases of roofing work while roofing work is in progress. Supervisor/Foremen must be fluent in the English language and maintain proper supervision of workmen.
- D. Maintain a copy of the Contract Documents in the possession of the Supervisor/Foreman and on the roof at all times.
- E. Source Limitations: Obtain all components of roof system from a single manufacturer. Secondary products that are required shall be recommended and approved in writing by the roofing system Manufacturer.
 - 1. Upon request of the Architect or Owner, submit Manufacturer's written approval of secondary components in list form, signed by an authorized agent of the Manufacturer.
 - 2. Manufacturer shall have direct authority and control over all fabrication of steel components as well as the raw materials used in their fabrication.
- F. Source Quality Control: Manufacturer shall have in place a documented, standardized quality control program such as ISO-9001 approval.

- G. Engage the Manufacturer's Field Representative to conduct required periodic inspections of work in progress as described herein and shall furnish written documentation of all such inspections.
- H. Manufacturer shall provide the project Owner with a written statement that they will provide site inspections three days per week that confirms that the project is being constructed as specified, by an experienced, full time employee of the company.

1.06 SUBMITTALS

- A. Comply with pertinent provisions of Division 01 Section "Submittal Procedures, unless otherwise indicated."
- B. Manufacturer's Installation Instructions: Submit installation instructions and recommendations indicating special precautions required for installing the membrane.
- C. Manufacturer's Certificate: Certify that roof system furnished is approved by Factory Mutual, Underwriters Laboratories, Warnock Hersey or approved third party testing facility in accordance with ASTM E108, Class [A] for external fire and meets local or nationally recognized building codes.
- D. Manufacturer's Certificate: Certify that the roof system furnished is approved or accepted by Factory Mutual Approval Standard 4470.
- E. Manufacturer's Certificate: Certify that materials are manufactured in the United States and conform to requirements specified herein, are chemically and physically compatible with each other, and are suitable for inclusion within the total roof system specified herein.
- F. Manufacturer's Certificate: Submit a certified copy of the roofing manufacturer's ISO 9001 compliance certificate.
- G. Test Reports: Submit test reports, prepared by an independent testing agency, for all modified bituminous sheet roofing, indicating compliance with ASTM D5147.
- H. Written certification from the roofing system manufacturer certifying the applicator is currently authorized for the installation of the specified roof system.
- I. Design Loads: Submit copy of manufacturer's minimum design load calculations according to ASCE 7-05, Method 2 for Components and Cladding, sealed by a registered professional engineer. In no case shall the design loads be taken to be less than those detailed in Design and Performance Criteria article of this specification.
- J. Specimen Warranty: Provide an unexecuted copy of the warranty specified for this Project, identifying the terms and conditions required of the Manufacturer and the Owner.

1.07 CLOSEOUT SUBMITTALS

- A. General: Comply with Requirements of Division 01 Section Closeout Submittals.
- B. Special Project Warranty: Provide specified warranty for the Project, executed by the authorized agent of the Manufacturer.
- C. Roofing Maintenance Instructions: Provide a manual of manufacturer's recommendations for maintenance of installed roofing systems.

1.08 DELIVERY, STORAGE AND HANDLING

- A. Deliver roofing materials to Project site in original containers with seals unbroken and labeled with manufacturer's name, product brand name and type, date of manufacture, approval or listing agency markings, and directions for storing and mixing with other components.

- B. Store liquid materials in their original undamaged containers in a clean, dry, protected location and within the temperature range required by roofing system manufacturer. Protect stored liquid material from direct sunlight.
 - 1. Discard and legally dispose of liquid material that cannot be applied within its stated shelf life.
- C. Protect roof insulation materials from physical damage and from deterioration by sunlight, moisture, soiling, and other sources. Store in a dry location. Comply with insulation manufacturer's written instructions for handling, storing, and protecting during installation.
- D. Handle and store roofing materials, and place equipment in a manner to avoid permanent deflection of deck.

1.09 WARRANTY

- A. Upon completion of installation, and acceptance by the Owner and Architect, the Manufacturer will supply to the Owner an "NDL" warranty, without monetary limitations in which manufacturer agrees to repair or replace components of roofing system that fail in materials or workmanship within specified warranty period.
 - 1. Warranty Period: Thirty (30) years from date of Substantial Completion.
- B. Installer's Warranty: Provide roofing installers warranty, to the membrane manufacturer, in which the roofing installer will, at his own expense, make or cause to be made such repairs to or replacements of said work as are necessary to correct faulty and defective work and as are necessary to maintain said work in a watertight condition.
 - 1. Warranty Period: Two (2) years from date of Substantial Completion.
- C. The Roof System Manufacturer shall provide annual inspection of the roof for the duration of the warranty at no fee to the Owner.

1.10 MANUFACTURER'S FIELD REPRESENTATION

- A. Manufacturer's Field Representative: An authorized, full-time employee of the roof system manufacturer shall be assigned to the project to conduct field observations during the installation phase.
- B. Regularly scheduled site observations shall be required by the manufacturer's field representative a minimum of three (3) days per week during the roofing installation period; exceptions being made for inclement weather, holidays, etc.
- C. Observation reports shall include the following:
 - 1. Written report/documentation of the installation progress at the time of the site visit to be delivered to the architect and owner within 48 hours of the site visit.
 - 2. This report shall include documentation of any issues/question and resolution.
 - 3. This report shall include record of directives given to the roofing contractor.
 - 4. Digital photographic documentation of the roofing progress; including documentation of specific issues and areas of concern.
 - 5. Each report shall contain project name, architect's project number, and date/time/duration of site visit.
- D. In addition to the progress observations, the manufacturer's representative must:
 - 1. Attend the roofing trade start-up meeting.
 - 2. Inspect and approve the roof substrate/deck prior to the start of roofing work.
- E. All observation reports shall be kept current and shall be delivered electronically to the architect and contractor within five (5) calendar days after the observation. Progress payments for roofing work may be withheld if observation report submissions are not current.

- F. After completion of all roofing work, and prior to acceptance of the roofing installation, the manufacturer's representative shall conduct an observation to document all roofing work to be corrected as a condition of acceptance.
 - 1. Each item requiring corrective work shall be identified (including specific location) and required corrective action shall be noted.
 - 2. The final observation report must be produced in writing with photographic back-up. Marking corrective items on the roof alone shall not be acceptable.
- G. Any failure by the Architect, the Owner's Representative, the Project Manager, or the roofing manufacturer's Technical Field Representative to observe, detect, pinpoint, or object to any defect or noncompliance with the requirements of the Roofing Manufacturer's requirements, the Contract Documents, the Project Specifications, the approved Shop Drawings and Engineering Data, and/or the Roofing Manufacturer's standard details – of work in progress or completed work – shall not relieve the Contractor of, or reduce, or in any way limit, his responsibility of full performance of the work required of him under the requirements of the Roofing Manufacturer, the Contract Documents, the Project Specifications, the approved Shop Drawings and Engineering Data, and/or the Roofing Manufacturer's standard details.

1.11 FIELD CONDITIONS

- A. Weather Limitations: Proceed with installation only when existing and forecasted weather conditions permit roofing system to be installed according to manufacturer's written instructions and warranty requirements.
- B. Do not apply roofing insulation or membrane to damp deck surface.
- C. Do not expose materials subject to water or solar damage in quantities greater than can be weatherproofed during same day.
- D. Phased Construction will not be accepted.

PART 2 - PRODUCTS

2.01 MANUFACTURERS

- A. Basis of Design Manufacturer: **The Garland Company, Inc.**
 - 1. 3800 East 91st Street, Cleveland, OH, 44105
 - 2. Manufacturer's Representative:
 - a. Blake Dieste; bdieste@garlandind.com; (M) 832-488-4783
- B. Modified bituminous roofing shall include but not be limited to:
 - 1. Base Ply Sheet Modified Membrane: Type II membrane complying with ASTM 6163, Grade S. Physical requirements below.
 - 2. Cap Ply Sheet Modified Membrane: Type III membrane complying with ASTM 6163, Grade G. Physical requirements below.
 - 3. Stripping Ply Sheet Modified Membrane: Type II membrane complying with ASTM 6163, Grade S. Physical requirements below.
 - 4. Base Flashing Assembly: Two ply modified, heat fused with the finished ply meeting Type III membrane complying with ASTM 6163, Grade G minimum requirements and base ply meeting Type II membrane complying with ASTM 6163, Grade S minimum.
- C. Basis of Design Materials, manufacturer's product designations, and/or manufacturer's names specified herein shall be regarded as the minimum standard of quality required for work of this Section. Comply with all manufacturer and contractor/fabricator quality and performance criteria specified in Part 1.

2.02 ROOFING SHEET MATERIALS

- A. Base Ply Sheet Modified Membrane: ASTM D 6163, Grade S, Type II, 110 mil SBS-modified asphalt sheet; suitable for application method specified, and as follows: HPR Torchbase.
1. Tensile Strength, ASTM D 5147:
 - a. 2 in/min. @ 73.4 +/- 3.6 deg. F MD 210 lbf/in XD 210 lbf/in
 - b. 50 mm/min. @ 23 +/- 2 deg. C MD 36.75 kN/m XD 36.75 kN/m
 2. Tear Strength, ASTM D 5147:
 - a. 2 in/min. @ 73.4 +/- 3.6 deg. F MD 250 lbf XD 250 lbf
 - b. 50 mm/min. @ 23 +/- 2 deg. C MD 1112N XD 1112N
 3. Elongation at Maximum Tensile, ASTM D 5147:
 - a. 2 in/min. @ 73.4 +/- 3.6 deg. F MD 4.0% XD 4.0%
 - b. 50 mm/min. @ 23 +/- 2 deg. C MD 4.0% XD 4.0%
 4. Low Temperature Flexibility, ASTM D5147, Passes -35 deg. F (-37 deg. C)
- B. Granule-Surfaced Roofing Cap Sheet: ASTM D 6163, Grade G, Type III, 195 mil SBS-modified asphalt sheet with fiberglass and polyester composite scrim; suitable for application method specified, and as follows: Stressply IV Plus UV Mineral.
1. Tensile Strength, ASTM D 5147:
 - a. 2 in/min. @ 73.4 +/- 3.6 deg. F MD 310 lbf/in XD 310 lbf/in
 - b. 50 mm/min. @ 23 +/- 2 deg. C MD 54.25 kN/m XD 54.25 kN/m
 2. Tear Strength, ASTM D 5147:
 - a. 2 in/min. @ 73.4 +/- 3.6 deg. F MD 510 lbf XD 510 lbf
 - b. 50 mm/min. @ 23 +/- 2 deg. C MD 2269 N XD 2269 N
 3. Elongation at Maximum Tensile, ASTM D 5147:
 - a. 2 in/min. @ 73.4 +/- 3.6 deg. F MD 6% XD 6%
 - b. 50 mm/min. @ 23 +/- 2 deg. C MD 6% XD 6%
 4. Low Temperature Flexibility, ASTM D 5147, Passes -40 deg. F (-40 deg. C)

2.03 BASE FLASHING SHEET MATERIALS

- A. Base Ply Sheet Modified Membrane: ASTM D 6163, Grade S, Type II, 110 mil SBS-modified asphalt sheet; suitable for application method specified, and as follows: HPR Torchbase.
1. Tensile Strength, ASTM D 5147:
 - a. 2 in/min. @ 73.4 +/- 3.6 deg. F MD 210 lbf/in XD 210 lbf/in
 - b. 50 mm/min. @ 23 +/- 2 deg. C MD 36.75 kN/m XD 36.75 kN/m
 2. Tear Strength, ASTM D 5147:
 - a. 2 in/min. @ 73.4 +/- 3.6 deg. F MD 250 lbf XD 250 lbf
 - b. 50 mm/min. @ 23 +/- 2 deg. C MD 1112N XD 1112N
 3. Elongation at Maximum Tensile, ASTM D 5147:
 - a. 2 in/min. @ 73.4 +/- 3.6 deg. F MD 4.0% XD 4.0%
 - b. 50 mm/min. @ 23 +/- 2 deg. C MD 4.0% XD 4.0%
 4. Low Temperature Flexibility, ASTM D5147, Passes -35 deg. F (-37 deg. C)
- B. Granule-Surfaced Roofing Cap Sheet: ASTM D 6163, Grade G, Type III, 195 mil SBS-modified asphalt sheet with fiberglass and polyester composite scrim; suitable for application method specified, and as follows: Stressply IV Plus UV Mineral.
1. Tensile Strength, ASTM D 5147:
 - a. 2 in/min. @ 73.4 +/- 3.6 deg. F MD 310 lbf/in XD 310 lbf/in
 - b. 50 mm/min. @ 23 +/- 2 deg. C MD 54.25 kN/m XD 54.25 kN/m

2. Tear Strength, ASTM D 5147:
 - a. 2 in/min. @ 73.4 +/- 3.6 deg. F MD 510 lbf XD 510 lbf
 - b. 50 mm/min. @ 23 +/- 2 deg. C MD 2269 N XD 2269 N
3. Elongation at Maximum Tensile, ASTM D 5147:
 - a. 2 in/min. @ 73.4 +/- 3.6 deg. F MD 6% XD 6%
 - b. 50 mm/min. @ 23 +/- 2 deg. C MD 6% XD 6%
4. Low Temperature Flexibility, ASTM D 5147, Passes -40 deg. F (-40 deg. C)

2.04 BITUMINOUS ROOFING MATERIALS

- A. General: Auxiliary materials provided or recommended by roofing system manufacturer for intended use and compatible with roofing.
- B. Liquid Flashing - Tuff-Flash: An asphaltic-polyurethane, low odor, liquid flashing material designed for specialized details unable to be waterproofed with typical modified membrane flashings.
- C. Asphalt Primer: ASTM D 41/D 41M. Garla-Prime.
- D. Asphalt Roofing Cement: ASTM D 4586, asbestos free, of consistency required by roofing system manufacturer for application. Flashing-Bond.
- E. Mastic Sealant: Polyisobutylene, plain or modified bitumen; non-hardening, non-migrating, non-skinning, and non-drying. Garla-Flex.
- F. Miscellaneous Materials: Provide those recommended by roofing system manufacturer.

2.05 SURFACING

- A. Roofing Granules: Ceramic-coated roofing granules as provided by the prime material manufacturer, No. 11 screen size with 100 percent passing No. 8 (2.36-mm) sieve and 98 percent of mass retained on No. 40 (0.425-mm) sieve, color to match roofing.
- B. Reflective Base Flashing Coating: Water-based Acrylic with self-curing Latex Polymers. Pyramic .

2.06 RELATED MATERIALS

- A. Plumbing stacks should be 4lb (1.8kg) sheet lead formed and rolled.
- B. Nails and Fasteners: Non-ferrous metal or galvanized steel, except that hard copper nails shall be used with copper; aluminum or stainless steel nails shall be used with aluminum; and stainless steel nails shall be used with stainless steel. Fasteners shall be self-clinching type of penetrating type as recommended by the manufacturer of the deck material. Nails and fasteners shall be flush-driven through flat metal discs of not less than one (1) inch diameter. Omit metal discs when one-piece composite nails or fasteners with heads not less than one (1) inch diameter are used.
- C. Butyl Tape: 100% solids, asbestos free and compressive tape designed to seal as recommended and furnished by the membrane manufacturer.

2.07 PERFORMANCE REQUIREMENTS

- A. General Performance: Installed roofing and base flashings shall withstand specified uplift pressures, thermally induced movement, and exposure to weather without failure due to defective manufacture, fabrication, installation, or other defects in construction. Roofing and base flashings shall remain watertight.
- B. Material Compatibility: Roofing materials shall be compatible with one another and adjacent materials under conditions of service and application required, as demonstrated by roofing manufacturer based on testing and field experience.

- C. Solar Reflectance Index: Not less than 70 when calculated according to ASTM E 1980, based on testing identical products by a qualified testing agency.
- D. Fire-Resistance Ratings: Comply with fire-resistance-rated assembly designs indicated. Identify products with appropriate markings of applicable testing agency.

PART 3 - EXECUTION

3.01 GENERAL INSTALLATION REQUIREMENTS

- A. Cooperate with manufacturer, inspection and test agencies engaged or required to perform services in connection with installing the roof system.
- B. Insurance/Code Compliance: Where required by code, install and test the roofing system to comply with governing regulation and specified insurance requirements.
- C. Protect other work from spillage of roofing materials and prevent materials from entering or clogging drains and conductors. Replace or restore other work damaged by installation of the modified bituminous roofing system.
- D. Coordinate installation of roofing system so insulation and other components of the roofing system not permanently exposed are not subjected to precipitation or left uncovered at the end of the workday or when rain is forecast.
 - 1. Provide tie-offs at end of each day's work to cover exposed roofing sheets and insulation with a course of coated felt set in roofing cement or hot roofing asphalt, with joints and edges sealed.
 - 2. Complete terminations and base flashings, and provide temporary seals to prevent water from entering completed sections of roofing system.
 - 3. Remove and discard temporary seals before beginning work on adjoining roofing.
- E. Substrate Joint Penetrations: Prevent bitumen from penetrating substrate joints, entering building, or damaging roofing system components or adjacent building construction.
- F. Apply roofing materials as specified by manufacturer's instructions:
 - 1. Keep roofing materials dry before and during application.
 - 2. Do not permit phased construction.
 - 3. Complete application of roofing plies, modified sheet and flashing in a continuous operation.
 - 4. Begin and apply only as much roofing in one day as can be completed that same day.
- G. Cut-Offs (Waterstops): At end of each day's roofing installation, protect exposed edge of incomplete work, including ply sheets and insulation.
- H. Broadcast minerals into the bleed out of bitumen while bitumen is at its recommended EVT temperature to achieve a monolithic appearance.

3.02 EXAMINATION

- A. Verify that deck surfaces and project conditions are ready to receive work of this Section.
- B. Verify that deck is supported and secured to structural members.
- C. Verify that deck is clean and smooth, free of depressions, projections or ripples, and is properly sloped.
- D. Verify that adjacent roof substrate components do not vary more than $[\frac{1}{4}]$ inch in height.
- E. Verify that deck surfaces are dry.
- F. Verify that openings, curbs, pipes, conduit, sleeves, ducts, and other items which penetrate the roof are set solidly, and that cant strips, wood nailing strips, and reglets are set in place.

3.03 SBS MODIFIED BITUMINOUS BASE PLY MEMBRANE INSTALLATION

- A. Install base ply according to roofing manufacturer's written instructions, starting at low point of roofing system. Extend roofing membrane sheets over and terminate beyond cants, installing as follows:
1. Lay out the roll in the course to be followed and unroll 6 feet (1.8 m).
 2. Using a roofing torch, heat the surface of the coiled portion until the burn-off backer melts away. At this point, the material is hot enough to lay into the substrate. Progressively unroll the sheet while heating and insure a proper bond.
 3. After the major portion of the roll is bonded, re-roll the first 6 feet (1.8 m) and bond it in a similar fashion.
 4. Repeat this operation with subsequent rolls with side laps of 4 inches (101 mm) and end laps of 8 inches (203 mm).
 5. Give each lap a finishing touch by passing the torch along the joint and spreading the melted bitumen evenly with a rounded trowel to insure a smooth, tight seal.
 6. Extend underlayment 2 inches (50 mm) beyond top edges of cants at wall and projection bases.
 7. Install base flashing ply to all perimeter and projections details.
- B. Laps: Accurately align roofing sheets, without stretching, and maintain uniform side and end laps. Stagger end laps. Completely bond and seal laps, leaving no voids.
1. Repair voids in laps and lapped seams not completely sealed.
- C. Install roofing sheets so side and end laps shed water.

3.04 SBS MODIFIED BITUMINOUS CAP SHEET MEMBRANE INSTALLATION

- A. Install modified bituminous cap sheet according to roofing manufacturer's written instructions, starting at low point of roofing system. Extend roofing membrane sheets over and terminate beyond cants, installing as follows:
1. Lay out the roll in the course to be followed and unroll 6 feet (1.8 m).
 2. Using a roofing torch, heat the surface of the coiled portion until the burn-off backer melts away. At this point, the material is hot enough to lay into the substrate. Progressively unroll the sheet while heating and insure a proper bond.
 3. After the major portion of the roll is bonded, re-roll the first 6 feet (1.8 m) and bond it in a similar fashion.
 4. Repeat this operation with subsequent rolls with side laps of 4 inches (101 mm) and end laps of 8 inches (203 mm).
 5. Give each lap a finishing touch by passing the torch along the joint and spreading the melted bitumen evenly with a rounded trowel to insure a smooth, tight seal.
 6. Immediately broadcast new granules into bleedout while hot bitumen is still at EVT. All loose granules to be removed at end of project.

3.05 BASE FLASHING AND STRIPPING INSTALLATION

- A. Install base flashing over cant strips and other sloped and vertical surfaces, at roof edges, and at penetrations through roof, and secure to substrates according to roofing system manufacturer's written instructions. Minimum base-flashing height of 8 inches (200 mm) is required. Install modified bituminous roofing sheet and cap sheet according to roofing manufacturer's written instructions, starting at low point of roofing system. Extend roofing membrane sheets over and terminate beyond cants, installing as follows:
1. Seal all curb, wall and parapet flashings with an application of mastic and mesh on a daily basis. Do not permit conditions to exist that will allow moisture to enter behind, around or under the roof or flashing membrane.

2. Prepare all walls, penetrations, expansion joints [and where shown on the drawings] to be flashed with asphalt primer at the rate of one hundred (100) square feet per gallon. Allow primer to dry tack free.
 3. Heat fuse entire base ply membrane until burn off paper is gone. Fully adhere membrane to the underlying substrate.
 4. After the laps have been tested and complete positive bond has been achieved, the applicator shall heat the seam edge and trowel along the seam edge. Troweling shall continue until a sloped, beveled edge has been produced.
 5. Heat fuse finished membrane in the same manner as base ply. Seal all vertical laps of flashing membrane with a three-course application of trowel-grade mastic and fiberglass mesh. Install termination bar at top of assembly and seal with a three-course application of trowel-grade mastic and fiberglass mesh.
 6. Terminate all base flashings using extruded aluminum termination bar. Three-course all terminations with PVC Mesh and specified mastic.
- B. Install roofing cap-sheet stripping where metal flanges and edgings are set on roofing according to roofing system manufacturer's written instructions.

3.06 REFLECTIVE BASE FLASHING COATING APPLICATION

- A. Base Flashing roofing plies and mastics shall be allowed to cure for thirty (30) days prior to application of the coating system.
- B. Prior to coating application, all existing non-embedded granule surfacing material shall be removed by means of a stiff bristle street broom, powered mechanical sweeper, or vacuuming. All loose dirt and dust remaining after granule removal must be broomed and/or vacuumed from the roof. All blisters, ridges and other imperfections must be secured so that the surface will be clean and dry and a secure base for coating application.
1. The first coat of the Base Coat shall be applied the same day as the surface is cleaned. In no case shall the coating be applied over a dirty surface.
 2. The coating system shall be roller applied in a cross hatch technique without causing runs or puddles.
 3. The coating system shall be evenly applied in at least 2 separate coats to achieve a minimum system of 22-32 mils dry film thickness. Allow thorough dry time between coats.
 4. No coating shall be applied if weather will not allow it to dry prior to exposure to precipitation or freezing temperatures.

3.07 ROOF DETAIL INSTALLATION

- A. Coordinate counter flashing, cap flashings, expansion joints, and similar work with modified bitumen roofing work (as specified in other Sections).
- B. Coordinate roof accessories, miscellaneous sheet metal accessory items, including piping vents and other devices with the roofing system work (as specified in other Sections).
- C. Curb Detail:
1. Minimum curb height is eight (8) inches. Prime vertically at a rate of one hundred (100) square feet per gallon and allow to dry.
 2. Set cant in bitumen. Run all field plies over cant a minimum of two (2) inches.
 3. Install base flashing assembly.
 4. Install pre-manufactured counter-flashing with fasteners and neoprene washers or per manufacturer's recommendations.
- D. Flanged Penetration Detail:
1. Minimum stack height is twelve (12) inches.

2. Run roof system over the entire surface of the roof. Seal the base of the stack with elastomeric sealant.
3. Prime both surfaces of flange of new sleeve. Install properly sized sleeves set in (1/4) inch bed of roof cement.
4. Install stripping ply prior to cap sheet installation.

3.08 FIELD QUALITY CONTROL

- A. Perform manufacturer's field inspection and as required a minimum of three (3) days per week.
- B. Correct defects or irregularities discovered during field inspection.
- C. Require attendance of roofing materials manufacturers' representatives at site during installation of the roofing system. A copy of the specification should also be on site at all times.

3.09 PROTECTING AND CLEANING

- A. Protect roofing system from damage and wear during remainder of construction period. When remaining construction does not affect or endanger roofing, inspect roofing for deterioration and damage, describing its nature and extent in a written report, with copies to Architect and Owner.
- B. Correct deficiencies in or remove roofing system that does not comply with requirements, repair substrates, and repair or reinstall roofing system to a condition free of damage and deterioration at time of Substantial Completion and according to warranty requirements.
- C. Remove bitumen adhesive drippings from all walls, windows, floors, ladders and finished surfaces.
- D. In areas where finished surfaces are soiled by asphalt or any other sources of soiling caused by work of this Section, consult manufacturer of surfaces for cleaning instructions and conform to their instructions.
- E. Repair or replace defaced or disfigured finishes caused by work of this Section.

3.10 CONSTRUCTION WASTE MANAGEMENT

- A. Remove and properly dispose of waste products generated during roofing procedures. Comply with requirements of authorities having jurisdiction.

3.11 FINAL INSPECTION

- A. At completion of roofing installation and associated work, meet with Contractor, Architect, installer, installer of associated work, Owner, roofing system manufacturer's representative, and other representatives directly concerned with performance of roofing system.
- B. Walk roof surface areas of the building, inspect perimeter building edges as well as flashing of roof penetrations, walls, curbs and other equipment. List all items requiring correction or completion and furnish copy of list to each party in attendance.
- C. The roofing system manufacturer reserves the right to request a thermographic scan of the roof during final inspection to determine if any damp or wet materials have been installed. The thermographic scan shall be provided by the Roofing Contractor.
- D. If core cuts verify the presence of damp or wet materials, the Roofing Contractor shall be required to replace the damaged areas at his own expense.
- E. Repair or replace deteriorated or defective work found at time above inspection as required to produce an installation which is free of damage and deterioration at time of Substantial Completion and according to warranty requirements.

- F. Notify the Owner and Architect upon completion of corrections.
- G. Following the final inspection, provide written notice of acceptance of the installation from the roofing system manufacturer.
- H. Immediately correct roof leakage during construction. If the Contractor does not respond within twenty four (24) hours, the Owner will exercise rights to correct the Work under the terms of the Conditions of the Contract.

END OF SECTION 07 52 16.12

THE GARLAND COMPANY INC.
 1100 WEST 11TH STREET
 FORT WORTH, TEXAS 76104
 PHONE: 817.734.1100
 FAX: 817.734.1101
 WWW.GARLANDCOMPANY.COM



JUVENILE JUSTICE CENTER ROOF REPLACEMENT
 GALVESTON COUNTY
 6101 ATTWATER AVENUE
 TEXAS CITY, TX 77590

| | |
|---------|--|
| DATE | 11/17/2018 |
| BY | N/A |
| CHECKED | J. GARLAND |
| DATE | 11/17/2018 |
| BY | N/A |
| SCALE | N/A |
| PROJECT | JUVENILE JUSTICE CENTER ROOF REPLACEMENT |
| JOB # | N/A |
| SHEET | R-1 |
| OF | 1 |
| SHEETS | |

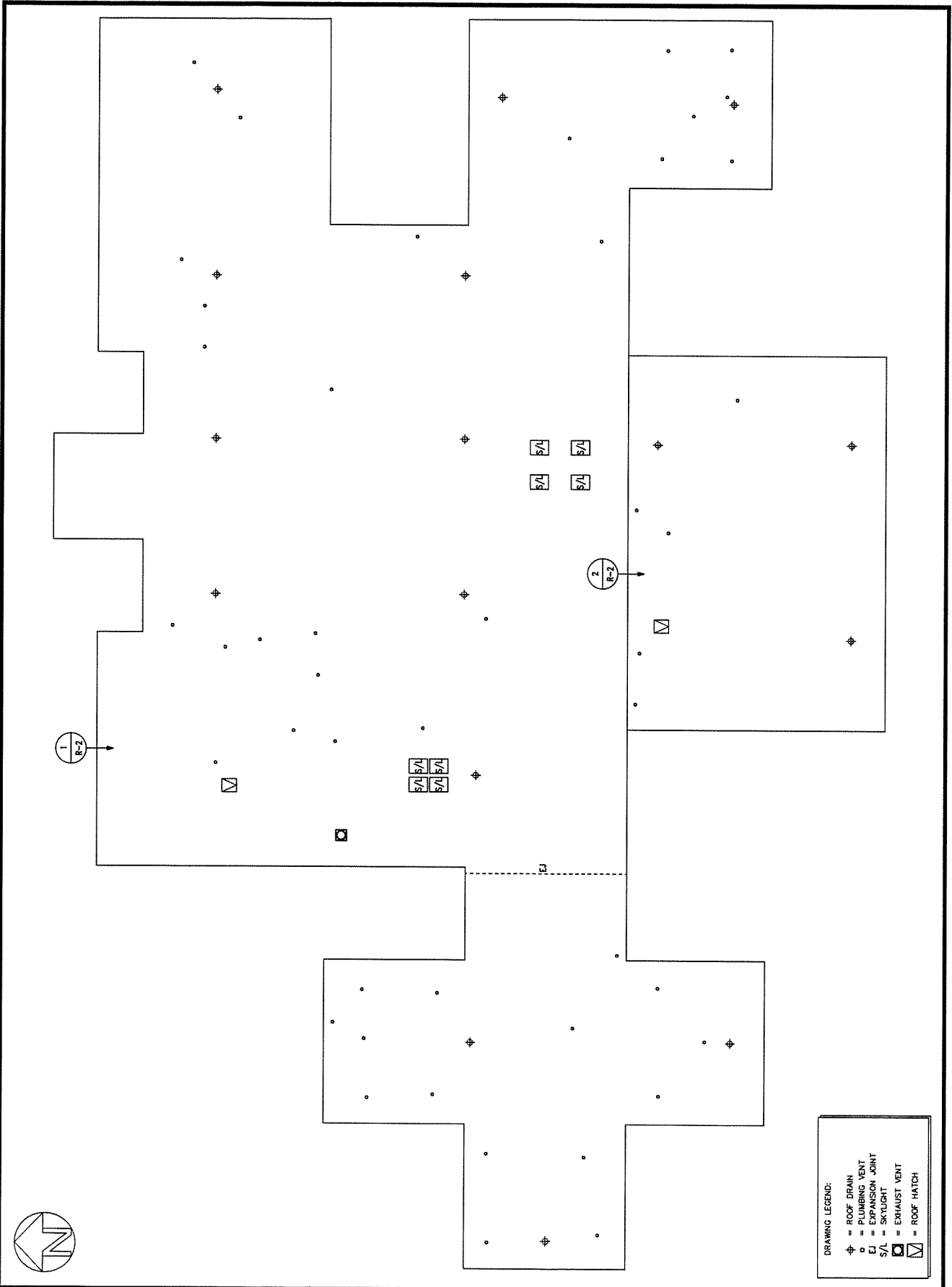

DRAWING LEGEND:

| | |
|-----|-------------------|
| ⊕ | = ROOF DRAIN |
| ○ | = PLUMBING VENT |
| ○ | = EXPANSION JOINT |
| S/L | = SKYLIGHT |
| ⊕ | = EXHAUST VENT |
| ⊕ | = ROOF HATCH |



| | |
|-------------|-------------------------|
| DATE | 11/17/2019 |
| DESIGNED BY | W. W. WILSON |
| CHECKED BY | R. W. WILSON |
| DATE | 11/17/2019 |
| PROJECT | JUVENILE JUSTICE CENTER |
| JOB # | N/A |
| SHEET | R-2 |

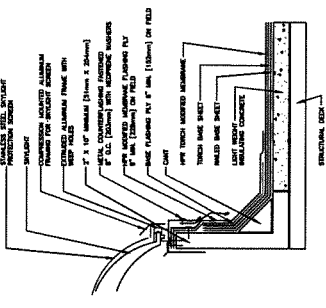

SKYLIGHT FLASHING DETAIL

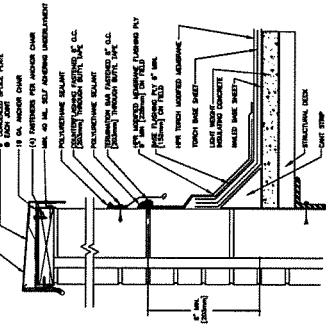

SURFACE-MOUNTED COUNTERFLASHING DETAIL

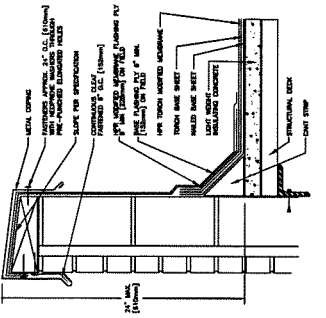

PERIMETER EDGE/COPING CAP DETAIL

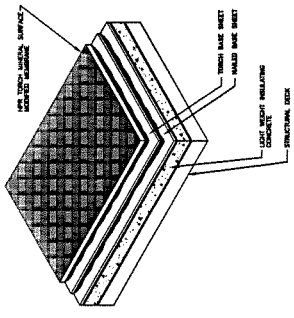

TYPICAL SECTION ROOF ASSEMBLY

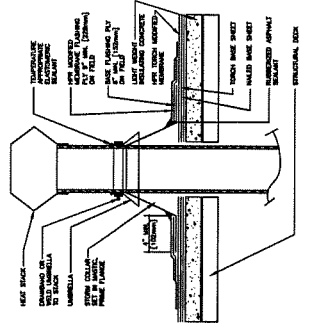

HEAT STACK FLASHING DETAIL

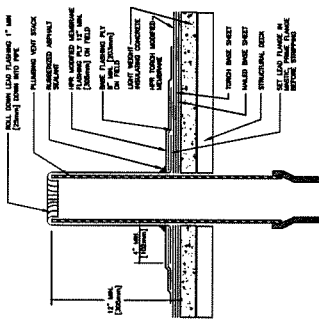

PLUMBING VENT FLASHING DETAIL (TYP.)

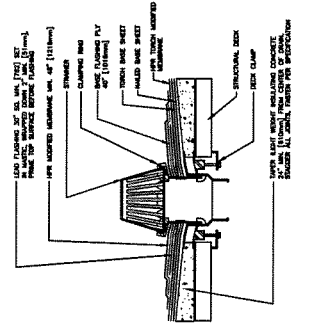

DRAIN DETAIL (TYP.)

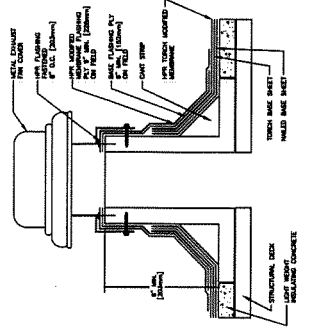

EXHAUST VENT DETAIL

THIS SPACE INTENTIONALLY LEFT BLANK

THIS SPACE INTENTIONALLY LEFT BLANK

THIS SPACE INTENTIONALLY LEFT BLANK

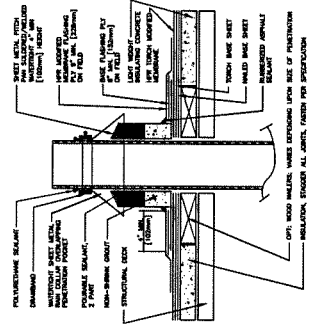

PITCH PAN W/ BONNET DETAIL

NOT USED

NOT USED

NOT USED