

COUNTY OF GALVESTON, TEXAS

BLUE HERON DRIVE IMPROVEMENTS

PROJECT NO. BV01

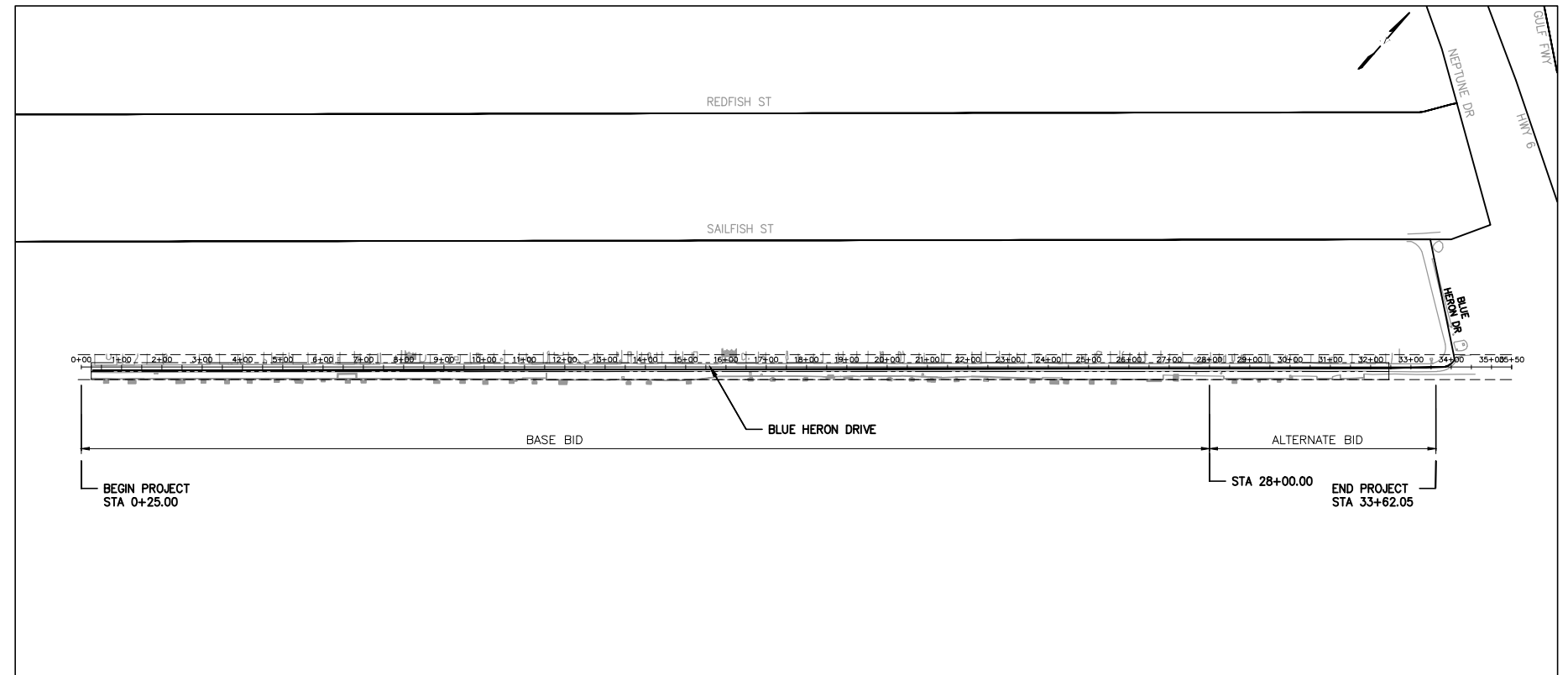
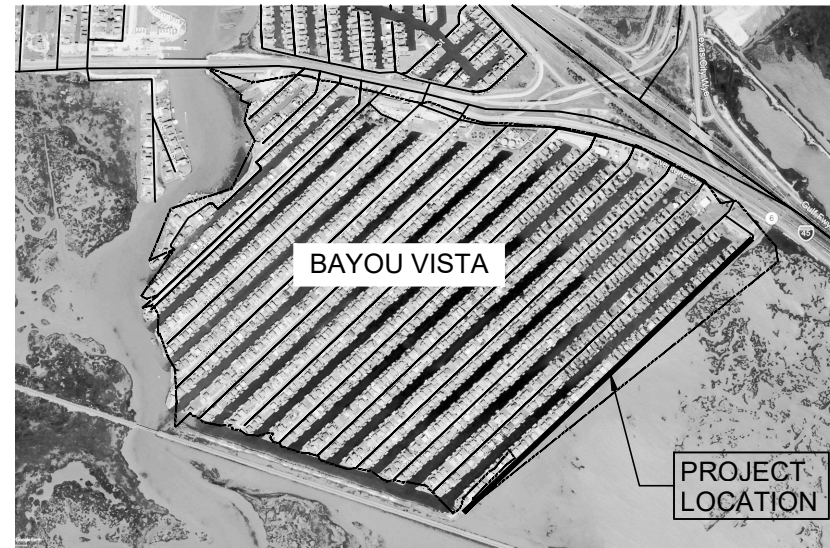
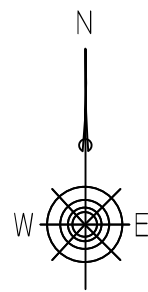

MARK HENRY
COUNTY JUDGE

DARRELL APFFEL
COMMISSIONER, PRECINCT NO. 1

JOE GIUSTI
COMMISSIONER, PRECINCT NO. 2

STEPHEN D. HOLMES
COMMISSIONER, PRECINCT NO. 3

KEN CLARK
COMMISSIONER, PRECINCT NO. 4

INDEX:

SHEET	DESCRIPTIONS:
01	COVER SHEET
02	GENERAL NOTES
03	UTILITY TABLE
04	TYPICAL SECTION
05	SURVEY INFORMATION
06	ROADWAY SCHEMATICS PLAN SHEET 1 OF 7
07	ROADWAY SCHEMATICS PLAN SHEET 2 OF 7
08	ROADWAY SCHEMATICS PLAN SHEET 3 OF 7
09	ROADWAY SCHEMATICS PLAN SHEET 4 OF 7
10	ROADWAY SCHEMATICS PLAN SHEET 5 OF 7
11	ROADWAY SCHEMATICS PLAN SHEET 6 OF 7
12	ROADWAY SCHEMATICS PLAN SHEET 7 OF 7
13	TYPE 'A' INLET DETAILS
14	DRIVEWAY TIE-IN AND STORM SEWER DETAILS
15	SWPPP SHEET 1 OF 1
16	SWPPP DETAIL
17	TRAFFIC CONTROL GUIDELINES-PROJECT APPROACH SIGNING
18	TRAFFIC CONTROL PLAN
19	SUMMARY OF EARTHWORKS SHEET
20-25	CROSS SECTIONS
26	BORING LOGS SHEET 1 OF 4
27	BORING LOGS SHEET 2 OF 4
28	BORING LOGS SHEET 3 OF 4
29	BORING LOGS SHEET 4 OF 4
30	PROJECT SIGN



ZARINKELK ENGINEERING
SERVICES, INC.

617 CAROLINE ST
Houston, TX 77002
Phone (832) 242-2426 FAX (832) 242-2445
Firm Registration No: F-004270



FILE INFO: Z:\Cdinveston County\Blue Heron\04 CAD\02 GENERAL NOTES.dwg PLOTTED BY: James Gaibort DATE: Sep 10, 2020 3:44pm

GENERAL NOTES:

1. ALL EXISTING ROADWAY MATERIAL REMOVED AND EXCESS SOIL MATERIAL EXCAVATED FROM ROADWAY SHALL BECOME THE PROPERTY OF THE CONTRACTOR AND SHALL BE PROPERLY DISPOSED OF OFF SITE.
2. THE CONTRACTOR WILL FURNISH AND MAINTAIN BARRICADES, WARNING SIGNS AND OTHER TRAFFIC CONTROL DEVICES AS PER LATEST TEXAS MUTCD AND TYPICAL CONSTRUCTION LAYOUTS OR AS DIRECTED BY THE ENGINEER.
3. ADVANCED WARNING SIGNS ARE TO BE SET TWO WEEKS PRIOR TO CONSTRUCTION ACTIVITIES AND REMAIN IN PLACE UNTIL ALL CONSTRUCTION ACTIVITIES ARE COMPLETE AND ACCEPTED.
4. THE CONTRACTOR WILL NOT BLOCK TRAFFIC WITHOUT PRIOR APPROVAL OF THE ENGINEER.
5. ACCESS TO BUSINESS AND PRIVATE PROPERTIES SHALL BE CONTINUOUSLY MAINTAINED EXCEPT FOR SHORT PERIODS DURING CONSTRUCTION OPERATIONS. INGRESS OR EGRESS SHALL BE PROVIDED AT DRIVEWAYS AS SOON AS PRACTICAL UPON COMPLETION OF WORK.
6. EQUIPMENT SHALL BE OFF STREETS BY DARK AND BEFORE DAWN.
7. POSITIVE DRAINAGE SHALL BE MAINTAINED AT ALL TIMES.
8. FLAGMAN WILL BE PROVIDED BY CONTRACTOR AS REQUIRED TO MAINTAIN TRAFFIC/PUBLIC SAFETY AT THE DISCRETION OF THE ENGINEER.
9. CONTRACTOR SHALL USE REASONABLE PRACTICAL METHODS TO CONTROL DUST AND TO REMOVE MATERIAL FROM EXISTING PAVED SURFACES.
10. THE LOCATION OF EXISTING UNDERGROUND UTILITIES AND SERVICE LINES AS INDICATED ON THE PLANS HAVE BEEN DETERMINED FROM AVAILABLE RECORDS ARE APPROXIMATE AND MAY BE INCOMPLETE. IT WILL BE UP TO CONTRACTOR TO LOCATE LINES AND OBSTACLES TO CONSTRUCTION AHEAD OF EXCAVATION.
11. CONTRACTOR SHALL PROTECT EXISTING UNDERGROUND FACILITIES/UTILITIES DURING INSTALLATION OF PROPOSED WORK. ANY DAMAGE TO EXISTING FACILITIES/UTILITIES WILL BE THE CONTRACTOR'S RESPONSIBILITY.
12. PAVED SURFACES SHALL BE PROTECTED FROM DAMAGE BY CONSTRUCTION EQUIPMENTS.
13. IRON RODS OR CORNER MONUMENTS DISTURBED DURING CONSTRUCTION TO BE REPLACED BY REGISTERED PUBLIC LAND SURVEYOR TO ORIGINAL PROPERTY CORNER AT NO SEPARATE PAY.
14. CONTRACTOR SHALL CONTACT THE ENGINEER AND THE CITY OF BAYOU VISTA AT LEAST 48 HOURS PRIOR TO CONSTRUCTION FOR NOTICE OF COMMENCEMENT.
15. CONTRACTOR TO NOTIFY ALL PROPERTY OWNERS A MINIMUM OF 24 HOURS PRIOR TO STARTING CONSTRUCTION.
16. CONTRACTOR TO REMOVE AND REPLACE EXISTING FENCES, POSTS, PLANTERS, MAIL BOXES AND TRASH CONTAINERS AS REQUIRED TO COMPLETE THE WORK.
17. ANY TEMPORARY STREET CROSSEOVERS REQUIRED BY CONTRACTOR, WILL BE AT CONTRACTORS EXPENSE. PRIOR APPROVAL BY ENGINEER IS REQUIRED.
18. ALL PROJECT WORK SCHEDULE AND CONSTRUCTION METHODS WILL NEED PRIOR APPROVAL BY ENGINEER.
19. CONTRACTOR SHALL BE EQUIPPED WITH THE SPREADER, WHICH SHALL BE CAPABLE OF SPREADING AND FINISHING SURFACE COURSE OF 3" HMA AND BASE COURSE OF 9" COLD-IN-PLACE IN FULL WIDTH OF THE PROPOSED PAVEMENT. CONTRACTOR SHALL SPREAD AND FINISH THE SURFACE COURSE AND BASE COURSE IN ONE FULL WIDTH OF THE PROPOSED PAVEMENT.

CENTERPOINT ENERGY FACILITIES

CAUTION: UNDERGROUND GAS FACILITIES

THE CONTRACTOR SHALL CONTACT THE UTILITY COORDINATING COMMITTEE AT 1-800 545 6005 OR 811 A MINIMUM OF 48 HOURS PRIOR TO CONSTRUCTION TO HAVE MAIN AND SERVICE LINES FIELD LOCATED.

- WHEN CENTERPOINT ENERGY PIPELINE MARKERS ARE NOT VISIBLE, CALL (713) 207-5463 OR 713-945-8037 (7:00 A.M. TO 4:30 P.M.) FOR STATUS OF THE LINE LOCATION REQUEST BEFORE EXCAVATION BEGINS.
- WHEN EXCAVATING WITHIN EIGHTEEN INCHES (18") OF THE INDICATED LOCATION OF CENTERPOINT ENERGY FACILITIES, ALL EXCAVATION MUST BE ACCOMPLISHED USING NON-MECHANIZED EXCAVATION PROCEDURES.
- WHEN CENTERPOINT ENERGY FACILITIES ARE EXPOSED, SUFFICIENT SUPPORT MUST BE PROVIDED TO THE FACILITIES TO PREVENT EXCESSIVE STRESS ON THE PIPING.
- FOR EMERGENCIES REGARDING GAS LINES CALL 713-659-3552 OR 713-207-4200.

THE CONTRACTOR IS FULLY RESPONSIBLE FOR ANY DAMAGES CAUSED BY HIS FAILURE TO EXACTLY LOCATE AND PRESERVE THESE UNDERGROUND FACILITIES.

CENTERPOINT ENERGY FACILITIES (CON'T)

WARNING: OVERHEAD ELECTRICAL LINES

OVERHEAD LINES MAY EXIST ON THE PROPERTY. THE LOCATION OF OVERHEAD LINES HAS NOT BEEN SHOWN ON THESE DRAWINGS AS THE LINES ARE CLEARLY VISIBLE, BUT YOU SHOULD LOCATE THEM PRIOR TO BEGINNING ANY CONSTRUCTION. TEXAS LAW, SECTION 752, HEALTH & SAFETY CODE FORBIDS ACTIVITIES THAT OCCUR IN CLOSE PROXIMITY TO HIGH VOLTAGE LINES, SPECIFICALLY:

- ANY ACTIVITY WHERE PERSON OR THINGS MAY COME WITHIN SIX(6) FEET OF LIVE OVERHEAD HIGH VOLTAGE LINES; AND
- OPERATING A CRANE, DERRICK, POWER SHOVEL, DRILLING RIG, PILE DRIVER, HOISTING EQUIPMENT, OR SIMILAR APPARATUS WITHIN 10 FEET OF LIVE OVERHEAD HIGH VOLTAGE LINES.

PARTIES RESPONSIBLE FOR THE WORK, INCLUDING CONTRACTORS ARE LEGALLY RESPONSIBLE FOR THE SAFETY OF CONSTRUCTION WORKERS UNDER THIS LAW. THIS LAW CARRIES BOTH CRIMINAL AND CIVIL LIABILITY. TO ARRANGE FOR LINES TO BE TURNED OFF OR REMOVED CALL CENTERPOINT ENERGY AT (713) 207-2222.

ACTIVITIES ON/OR ACROSS CENTERPOINT ENERGY FEE OR EASEMENT PROPERTY.

NO APPROVAL TO USE, CROSS OR OCCUPY CENTERPOINT FEE OR EASEMENT PROPERTY IS GIVEN. IF YOU NEED TO USE CENTERPOINT PROPERTY, PLEASE CONTACT OUR SURVEYING & RIGHT OF WAY DIVISION AT (713)207-6248 OR (713)207-5769.

AT&T TEXAS/SWBT FACILITIES

1. THE LOCATIONS OF AT&T TEXAS/SWBT FACILITIES ARE SHOWN IN AN APPROXIMATE WAY ONLY. THE CONTRACTOR SHALL DETERMINE THE EXACT LOCATION BEFORE COMMENCING WORK. HE AGREES TO BE FULLY RESPONSIBLE FOR ANY AND ALL DAMAGES WHICH MAY BE OCCASIONED BY THIS FAILURE TO EXACTLY LOCATE AND PRESERVE THESE UNDERGROUND UTILITIES.
2. THE CONTRACTOR SHALL CALL 1-800-344-8377 (TEXAS 811) A MINIMUM OF 48 HOURS PRIOR TO CONSTRUCTION TO HAVE UNDERGROUND LINES FIELD LOCATED.
3. WHEN EXCAVATING WITHIN EIGHTEEN INCHES (18") OF THE INDICATED LOCATION OF THE AT&T TEXAS/SWBT FACILITIES, ALL EXCAVATIONS MUST BE ACCOMPLISHED USING NON-MECHANIZED EXCAVATION PROCEDURES. WHEN BORING, THE CONTRACTOR SHALL EXPOSE THE AT&T TEXAS/SWBT FACILITIES.
4. WHEN AT&T TEXAS/SWBT FACILITIES ARE EXPOSED, CONTRACTOR TO WILL PROVIDE SUPPORT TO PREVENT DAMAGE TO THE CONDUIT DUCTS OR CABLES. WHEN EXCAVATING NEAR TELEPHONE POLES, THE CONTRACTOR SHALL BRACE THE POLE FOR SUPPORT.
5. THE PRESENCE OR ABSENCE OF AT&T Texas/SWBT UNDERGROUND CONDUIT FACILITIES OR BURIED CABLE FACILITIES SHOWN ON THE THESE PLANS DOES NOT MEAN THAT THERE ARE NO DIRECT BURIED CABLE OR OTHER CABLES IN CONDUIT IN THE AREA.
6. PLEASE CONTACT THE AT&T TEXAS DAMAGE PREVENTION MANAGER MR. ROOSEVELT LEE JR. AT (713)567-4552 OR E-MAIL HIM AT RL7259@ATT.COM, IF THERE ARE QUESTIONS ABOUT BORING OR EXCAVATING NEAR OUR AT&T Texas/SWBT FACILITIES.

OTHER NOTES

1. UNDERGROUND PIPELINES ARE SHOWN ACCORDING TO BEST AVAILABLE INFORMATION. CONTRACTOR TO PROCEED WITH CAUTION DURING EXCAVATION. CONTRACTOR TO COORDINATE WITH PIPELINE OWNER IN CASE OF CONFLICTS OR QUESTIONS. CONTRACTOR SHALL VERIFY LOCATION OF UNDERGROUND UTILITIES BY CONTACTING THE UTILITY COORDINATING COMMITTEE FORTY-EIGHT (48) HOURS BEFORE BEGINNING WORK AT 1 (800) 545-6005 OR 811.
2. ALL EXISTING UNDERGROUND UTILITIES ARE NOT GUARANTEED TO BE COMPLETE OR DEFINITE. THE APPROXIMATE LOCATIONS OF KNOWN EXISTING UTILITIES ARE SHOWN. CONTRACTOR SHALL DETERMINE THE EXACT SIZE AND HORIZONTAL AND VERTICAL LOCATIONS IN THE FIELD PRIOR TO COMMENCING WORK.
3. ANY PERMANENT RELOCATION OF AN EXISTING UTILITY NOT SHOWN ON THE DRAWINGS SHALL BE APPROVED BY THE ENGINEER PRIOR TO RELOCATION AND SHALL CONFORM TO THE APPLICABLE STANDARDS OF GOVERNING AUTHORITIES.
4. CONTRACTOR SHALL PROTECT EXISTING UNDERGROUND FACILITIES DURING INSTALLATIONS OF PROPOSED WORK.

NO.	REVISIONS	DATE	NAME

**GALVESTON COUNTY
ENGINEERING
DEPARTMENT**



Zarinkel
Engineering Services, Inc.
817 Caroline St.
Houston, Texas 77002
Ph: 832.242.2426
Fax: 832.242.2445
Firm Reg. # F-004270



PROJECT TITLE: BLUE HERON DRIVE		PROJECT ID: BV01
DRAWN BY:	SHEET DESCRIPTION: GENERAL NOTES	SHEET NO: 2 / 30
CK'D BY:	APPROVED BY:	
SCALE:	DATE: 9/10/2020	

FILE INFO: Z:\Galveston County\Blue Heron\04 CAD\03 UTILITY TABLE.dwg PLOTTED BY: James Gorbort DATE: Sep 10, 2020 3:44pm

Utility Table												
No.	Station		Utility Type	Owner	Does Utility Co. have an Easement	Conflict	Probed	Contact Name	Address	Phone No.	Email	Describe Conflict (if applicable)
	From	TO			Yes/No	Yes/No	Yes/No					
1	Project Length		Gas Pipeline	One Gas Texas Gas Service	No	No	No	Nancy Stence	5613 Ave F, Austin TX 78751	512-370-8318 nancy.stence@onegas.com		Outside ROW Limits West of ROW Limits.
2	33+17.21		Gas Pipeline	One Gas Texas Gas Service	No	No	No	Nancy Stence	5613 Ave F, Austin TX 78751	512-370-8318 nancy.stence@onegas.com		Outside ROW Limits West of ROW Limits.
3	00+26.00	02+78.00	Underground Electric Conduit with Electric Pedestal	CenterPoint Energy	No	No	No	Cynthia Martinez	1111 Louisiana, Suite 2258C, Houston TX 77002	713-207-6555 cindy.martinez@centerpointenergy.com		Outside ROW Limits West of ROW Limits.
4	03+99.00	06+39.00	Underground Electric Conduit with Electric Pedestal	CenterPoint Energy	No	No	No	Cynthia Martinez	1111 Louisiana, Suite 2258C, Houston TX 77002	713-207-6555 cindy.martinez@centerpointenergy.com		Outside ROW Limits West of ROW Limits.
5	07+38.00	09+78.00	Two - Underground Electric Conduit with Electric Pedestal	CenterPoint Energy	No	No	No	Cynthia Martinez	1111 Louisiana, Suite 2258C, Houston TX 77002	713-207-6555 cindy.martinez@centerpointenergy.com		Outside ROW Limits West of ROW Limits.
6	10+99.00	13+40.00	Two - Underground Electric Conduit with Electric Pedestal	CenterPoint Energy	No	No	No	Cynthia Martinez	1111 Louisiana, Suite 2258C, Houston TX 77002	713-207-6555 cindy.martinez@centerpointenergy.com		Outside ROW Limits West of ROW Limits.
7	14+37.00	16+39.00	Two - Underground Electric Conduit with Electric Pedestal	CenterPoint Energy	No	No	No	Cynthia Martinez	1111 Louisiana, Suite 2258C, Houston TX 77002	713-207-6555 cindy.martinez@centerpointenergy.com		Outside ROW Limits West of ROW Limits.
8	17+63.00	19+40.00	Two - Underground Electric Conduit with Electric Pedestal	CenterPoint Energy	No	No	No	Cynthia Martinez	1111 Louisiana, Suite 2258C, Houston TX 77002	713-207-6555 cindy.martinez@centerpointenergy.com		Outside ROW Limits West of ROW Limits.
9	20+38.00	22+39.00	Two - Underground Electric Conduit with Electric Pedestal	CenterPoint Energy	No	No	No	Cynthia Martinez	1111 Louisiana, Suite 2258C, Houston TX 77002	713-207-6555 cindy.martinez@centerpointenergy.com		Outside ROW Limits West of ROW Limits.
10	23+38.00	25+38.00	Two - Underground Electric Conduit with Electric Pedestal	CenterPoint Energy	No	No	No	Cynthia Martinez	1111 Louisiana, Suite 2258C, Houston TX 77002	713-207-6555 cindy.martinez@centerpointenergy.com		Outside ROW Limits West of ROW Limits.
11	26+39.00	28+39.00	Two - Underground Electric Conduit with Electric Pedestal	CenterPoint Energy	No	No	No	Cynthia Martinez	1111 Louisiana, Suite 2258C, Houston TX 77002	713-207-6555 cindy.martinez@centerpointenergy.com		Outside ROW Limits West of ROW Limits.
12	29+47.00	31+88.00	Two - Underground Electric Conduit with Electric Pedestal	CenterPoint Energy	No	No	No	Cynthia Martinez	1111 Louisiana, Suite 2258C, Houston TX 77002	713-207-6555 cindy.martinez@centerpointenergy.com		Outside ROW Limits West of ROW Limits.
13	01+59.00	32+96.00	Overhead Electric Powerline with Pole	CenterPoint Energy	No	Yes	No	Cynthia Martinez	1111 Louisiana, Suite 2258C, Houston TX 77002	713-207-6555 cindy.martinez@centerpointenergy.com		Outside ROW Limits West of ROW Limits.
14	33+07.00	34+60.00	Overhead Electric Powerline with Pole	CenterPoint Energy	No	No	No	Cynthia Martinez	1111 Louisiana, Suite 2258C, Houston TX 77002	713-207-6555 cindy.martinez@centerpointenergy.com		Outside ROW Limits East of ROW Limits.
15	00+93.00	End Project	Underground Telephone Cable with Pedestal	A T & T	No	Yes*	No	Kathy Tinney	CobbFendley, 1920 Country PI Pkwy, Suite 310, Pearland, TX 77584	713-485-8128 Kt145j@att.com		Inside ROW Limits, Adjacent to West ROW Limits. Potential conflict with Proposed Asphalt Pavement
16	06+61.00	End Project	8-inch Sanitary Sewer	GC MUD 12	No	No	No		2929 Highway 6, Suite 300, Bayou Vista, TX 77563	409-935-6111 mud12@comcast.net		Outside ROW Limits West of ROW Limits.
17	Begin Project	End Project	Water line, water meter, water valve and Fire Hydrant	GC MUD 12	No	No	No		2929 Highway 6, Suite 300, Bayou Vista, TX 77563	409-935-6111 mud12@comcast.net		Outside ROW Limits West of ROW Limits.

* WHEN WORKING WITHIN EIGHTEEN INCHES (18") OF THE INDICATED LOCATION OF UNDERGROUND UTILITY FACILITIES, ALL EXCAVATIONS MUST BE ACCOMPLISHED USING NON-MECHANIZED EXCAVATION PROCEDURES.

NO.	REVISIONS	DATE	NAME

GALVESTON COUNTY
ENGINEERING
DEPARTMENT

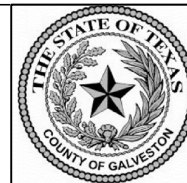

Zarinkel
Engineering Services, Inc.
817 Caroline St.
Houston, Texas
Ph: 832.242.2426
Fax: 832.242.2445
Firm Reg. # F-004270



PROJECT TITLE: BLUE HERON DRIVE		PROJECT ID: BV01
DRAWN BY:	SHEET DESCRIPTION: UTILITY TABLE	SHEET NO: 3 / 30
CK'D BY:	APPROVED BY:	
SCALE:	DATE: 9/10/2020	

FILE INFO: Z:\Galveston County\Blue Heron\04 CAD\04 PAVEMENT TYPICAL SECTION DETAILS.dwg PLOTTED BY: James Gaibort DATE: Sep 10, 2020 3:44pm

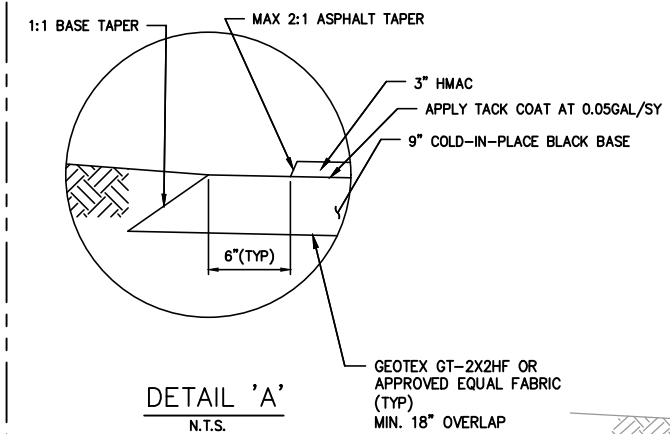

* PROVIDE PROPOSE GRADE FOR DRAIN TO THE BAY

NOTE
 SODDING IS PROPOSED TO COVER ANY DISTURBED SURFACE AREA DURING CONSTRUCTION, WHICH IS NOT PROPOSED TO PAVED OVER ENTIRE PROJECT LENGTH. ACTUAL LIMITS OF SODDING SHALL BE VERIFIED IN THE FIELD AND APPROVED BY THE ENGINEER DURING CONSTRUCTION.

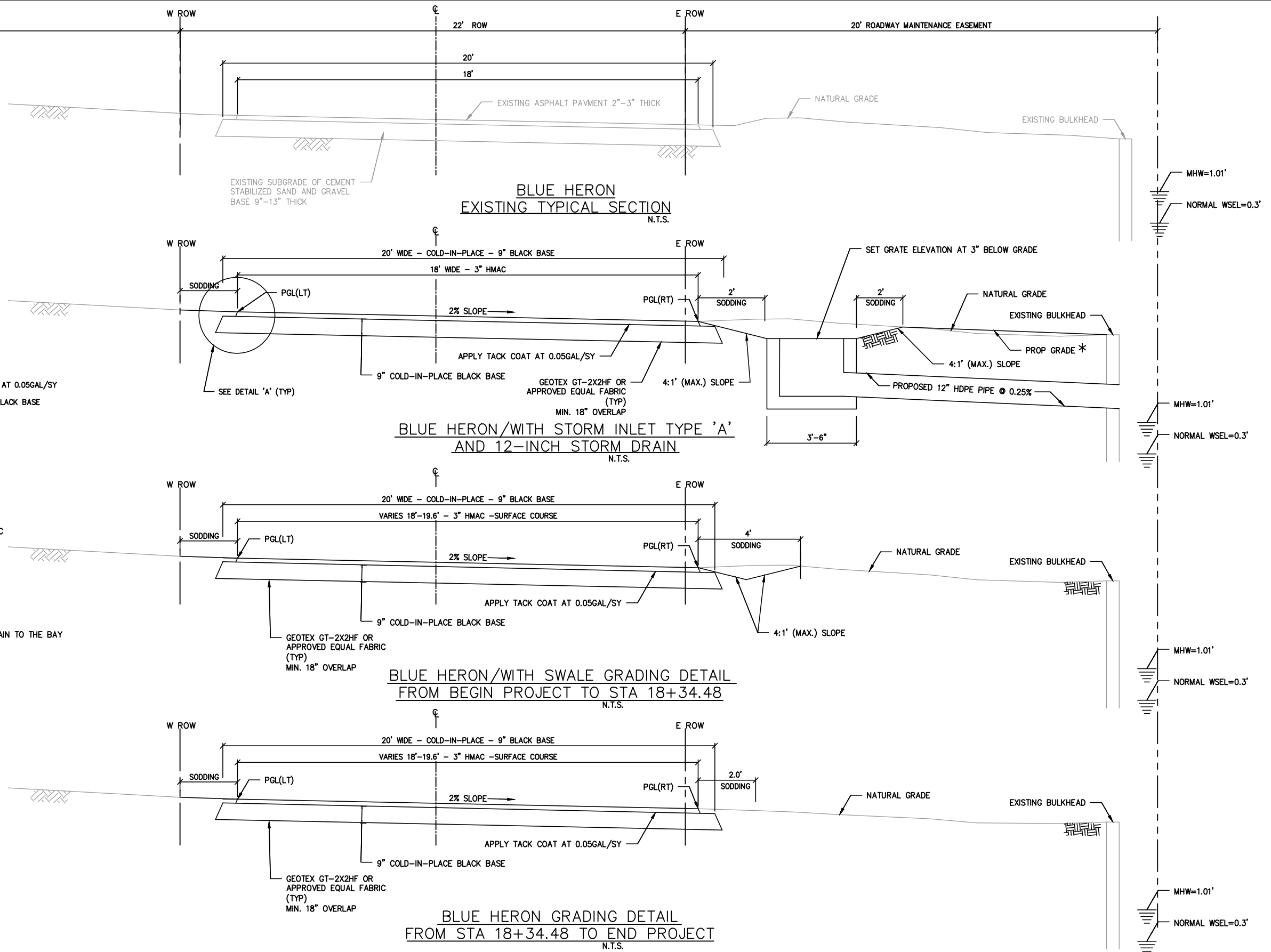

NO.	REVISIONS	DATE	NAME

**GALVESTON COUNTY
 ENGINEERING
 DEPARTMENT**



Zarinkel
 Engineering Services, Inc.
 817 Caroline St
 Houston, Texas 77002
 Ph: 832.242.2426
 Fax: 832.242.2445
 Firm Reg. # F-004270



PROJECT TITLE: BLUE HERON DRIVE		PROJECT ID: BV01
DRAWN BY:	SHEET DESCRIPTION:	SHEET NO: 4 / 30
CK'D BY:	GRADING DETAIL	
DATE: 9/10/2020	APPROVED BY:	

FILE INFO: Z:\Galveston County\Blue Heron\04 CAD\05 BLUE HERON CONTROL.dwg PLOTTED BY: James Gaibort DATE: Sep 10, 2020 3:58pm

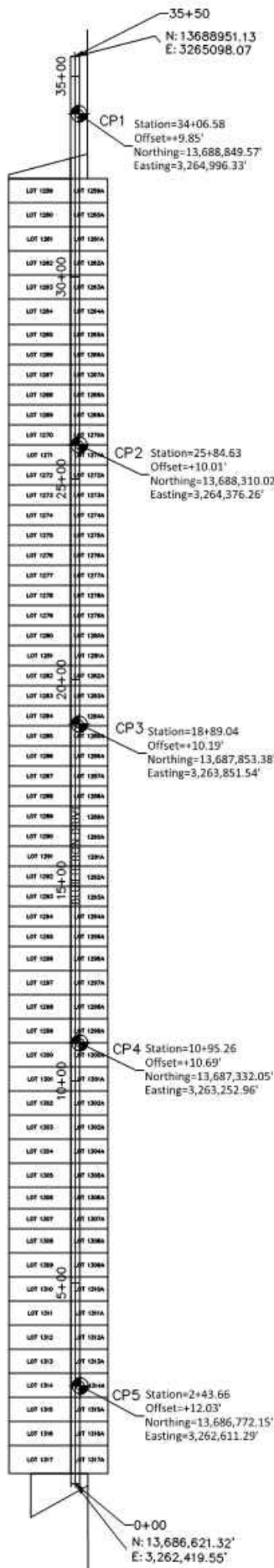

SCALE: 1" = 200'

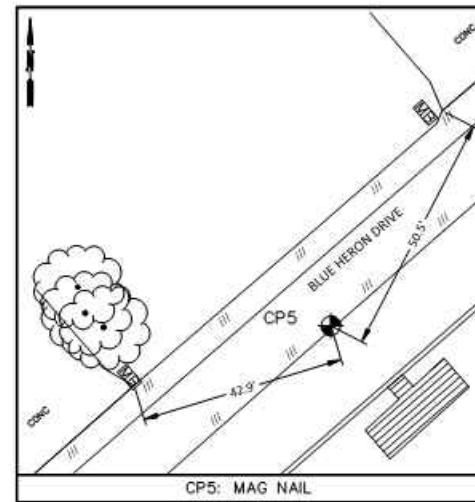
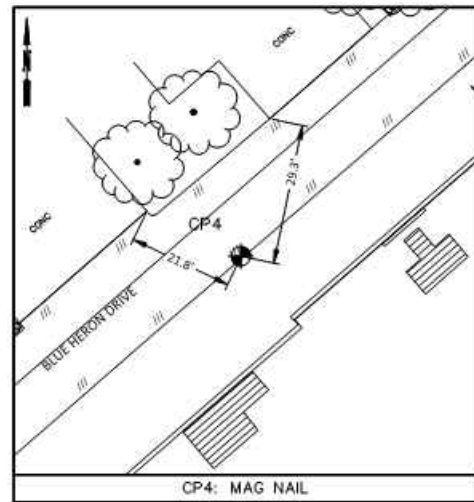
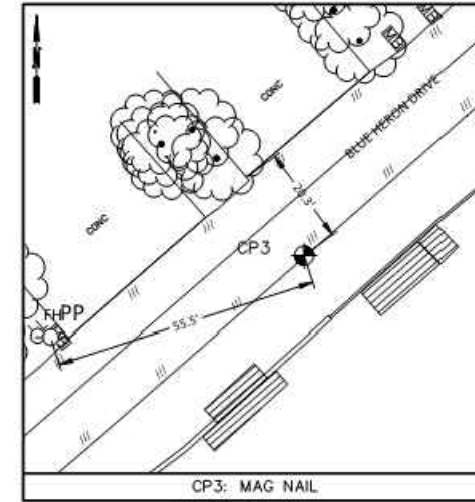
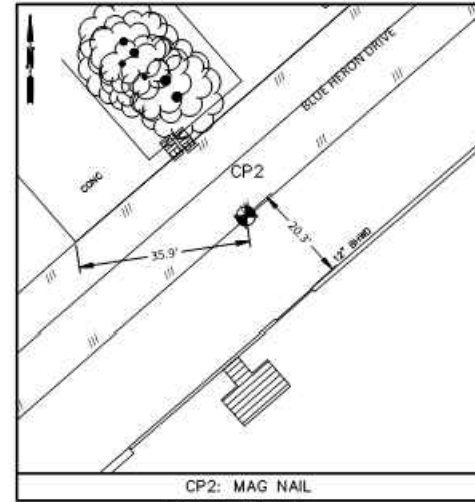
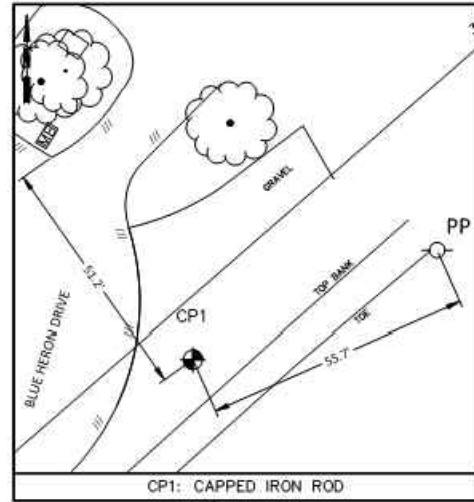

BENCHMARK
 DESIGNATION - 877 1486 C
 PID : D09997
 NAVD 88 GEOID 12A
 ELEVATION: = 11.9 FEET

TO REACH FROM THE INTERSECTION OF 51ST STREET AND US HIGHWAY 45 IN GALVESTON, TEXAS, PROCEED WEST ON US HIGHWAY 45 FOR 4.9 MI (7.9 KM) TO EXIT NUMBER 4 TOWARDS THE VILLAGE OF TIKI ISLAND. PROCEED 0.3 MI (0.5KM) AND TURN RIGHT ONTO VIRGINIA POINT ROAD. CONTINUE 0.3 MI ON VIRGINIA POINT ROAD BEARING RIGHT WHEN IT DEVERTS TO CROSS UNDER TO OLD RAILROAD BRIDGE TO THE MARK ON YOUR LEFT. THE BENCH MARK IS LOCATED 26.41 FEET (8.0 M) SOUTHWEST OF THE WESTERN MOST CORNER OF A CONCRETE WALL. 45 FEET (13.7 M) NORTHEAST OF THE NORTHERN MOST RAIL OF A RAILROAD TRACK. 94 FEET (28.7 M) NORTHEAST OF OLD HIGHWAY 75.

ALL COORDINATES ARE GRID VALUES BASED ON THE TEXAS STATE COORDINATE SYSTEM NAD83 EPOCH 2010 US SURVEY FEET.

CP No.	NORTHING	EASTING	ELEVATION IN FEET	DESCRIPTION
1	13688849.57	3264996.33	4.27	CAPPED IRON ROD
2	13688310.02	3264376.26	5.09	MAG NAIL
3	13687853.38	3263851.54	4.96	MAG NAIL
4	13687332.05	3263252.96	4.80	MAG NAIL
5	13686772.15	3262611.29	4.75	MAG NAIL

I, the undersigned, a Registered Professional Land Surveyor of the State of Texas, do hereby certify that this survey was made on the ground and is true and correct to the best of my knowledge and belief.

Robert D. Ellis
 Registered Professional
 Land Surveyor No. 4006

**CONTROL SHEET
 FOR
 BLUE HERON DRIVE
 BAYOU VISTA
 GALVESTON COUNTY, TEXAS**

ELLIS SURVEYING SERVICES, LLC
 2805 25th Avenue North
 Texas City, Texas 77590
 www.ellisurvey.com
 Texas Firm Reg. No. 100340-00

SCALE: 1" = 200'	PROJ. NUMBER 2863	DATE: 1-2-2020
PHONE: (409)-938-8700	SHEET 05 OF 30	

FILE INFO: Z:\Galveston County\Blue Heron\04 CAD\06 - 12 C-001-001.dwg PLOTTED BY: James Gaibart DATE: Sep 10, 2020 3:45pm

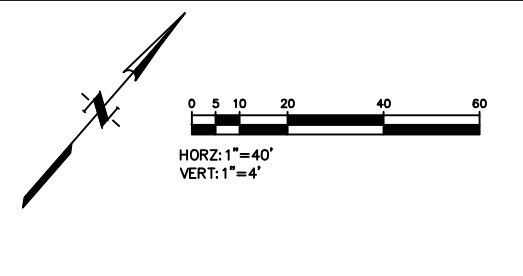
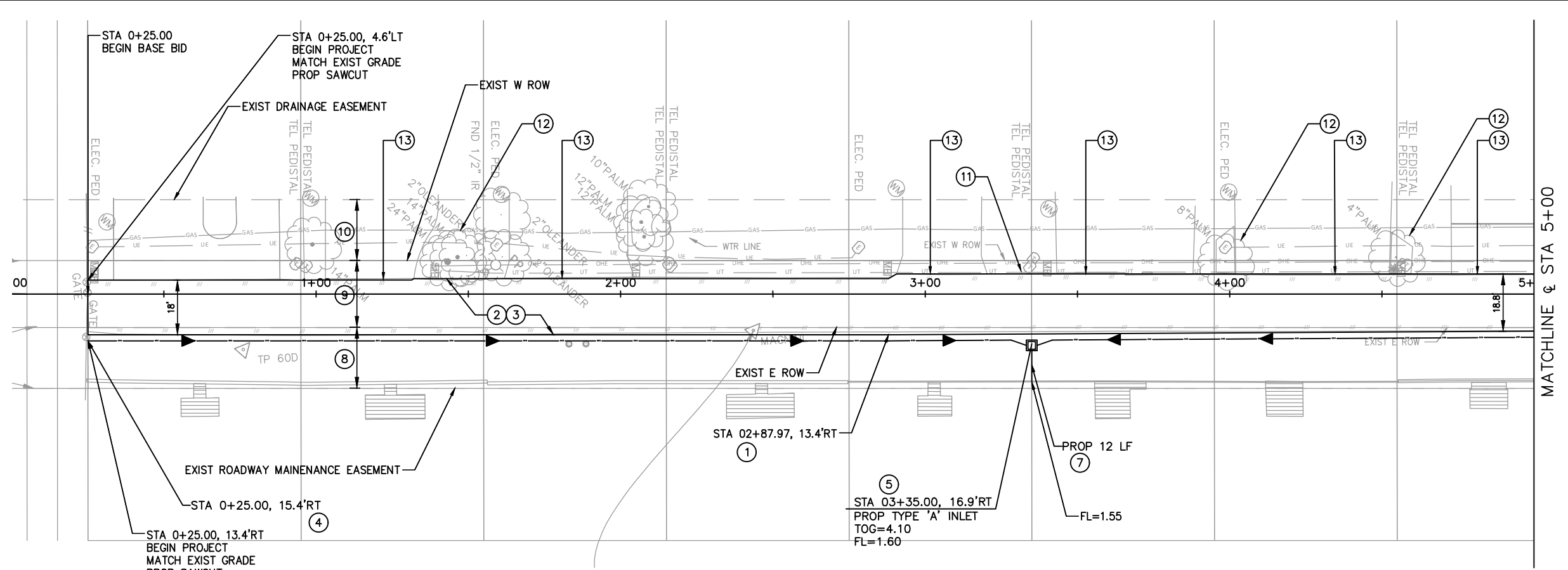

BENCHMARK
 DESIGNATION - 877 1486 C
 PID : D09997
 NAVD 88 GEOID 12A
 ELEVATION: = 11.9 FEET

TO REACH FROM THE INTERSECTION OF 51ST STREET AND US HIGHWAY 45 IN GALVESTON, TEXAS, PROCEED WEST ON US HIGHWAY 45 FOR 4.9 MI (7.9 KM) TO EXIT NUMBER 4 TOWARDS THE VILLAGE OF TIKI ISLAND. PROCEED 0.3 MI (0.5KM) AND TURN RIGHT ONTO VIRGINIA POINT ROAD. CONTINUE 0.3 MI ON VIRGINIA POINT ROAD BEARING RIGHT WHEN IT DEVERTS TO CROSS UNDER TO OLD RAILROAD BRIDGE TO THE MARK ON YOUR LEFT. THE BENCH MARK IS LOCATED 26.41 FEET (8.0 M) SOUTHWEST OF THE WESTERN MOST CORNER OF A CONCRETE WALL. 45 FEET (13.7 M) NORTHEAST OF THE NORTHERN MOST RAIL OF A RAILROAD TRACK. 94 FEET (28.7 M) NORTHEAST OF OLD HIGHWAY 75.

- NOTE:**
- ① PROPOSED EDGE OF PAVEMENT AT PGL.
 - ② SAWCUT, REMOVE AND DISPOSE/RECYCLE EXISTING PAVEMENT WITH SUBGRADE.
 - ③ PROPOSED 3-INCH HMAC SURFACE COURSE OVER 9-INCH COLD-IN-PLACE RECYCLED BASE.
 - ④ BEGIN PROPOSED SWALE.
 - ⑤ PROPOSED TYPE 'A' INLET.
 - ⑥ END PROPOSED SWALE.
 - ⑦ 12" HDPE @ 0.25%.
 - ⑧ 20' WIDE EXISTING ROAD MAINTENANCE EASEMENT.
 - ⑨ 22' WIDE EXISTING ROW.
 - ⑩ 20' WIDE EXISTING DRAINAGE EASEMENT.
 - ⑪ PUC - POTENTIAL UTILITY CONFLICT.
 - ⑫ IMPLEMENT TREE PROTECTION.
 - ⑬ FINISHED PROPOSED GRADE TO EDGE OF DRIVEWAY.

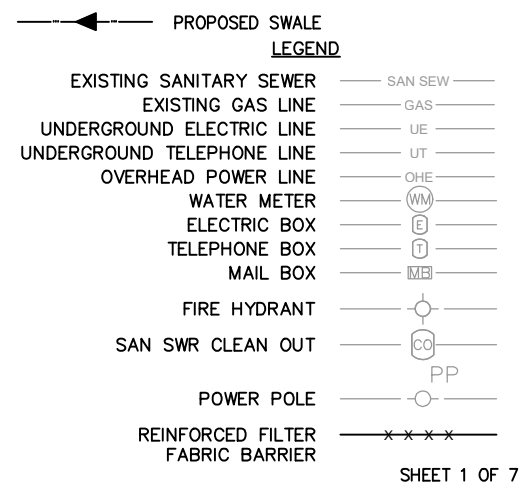
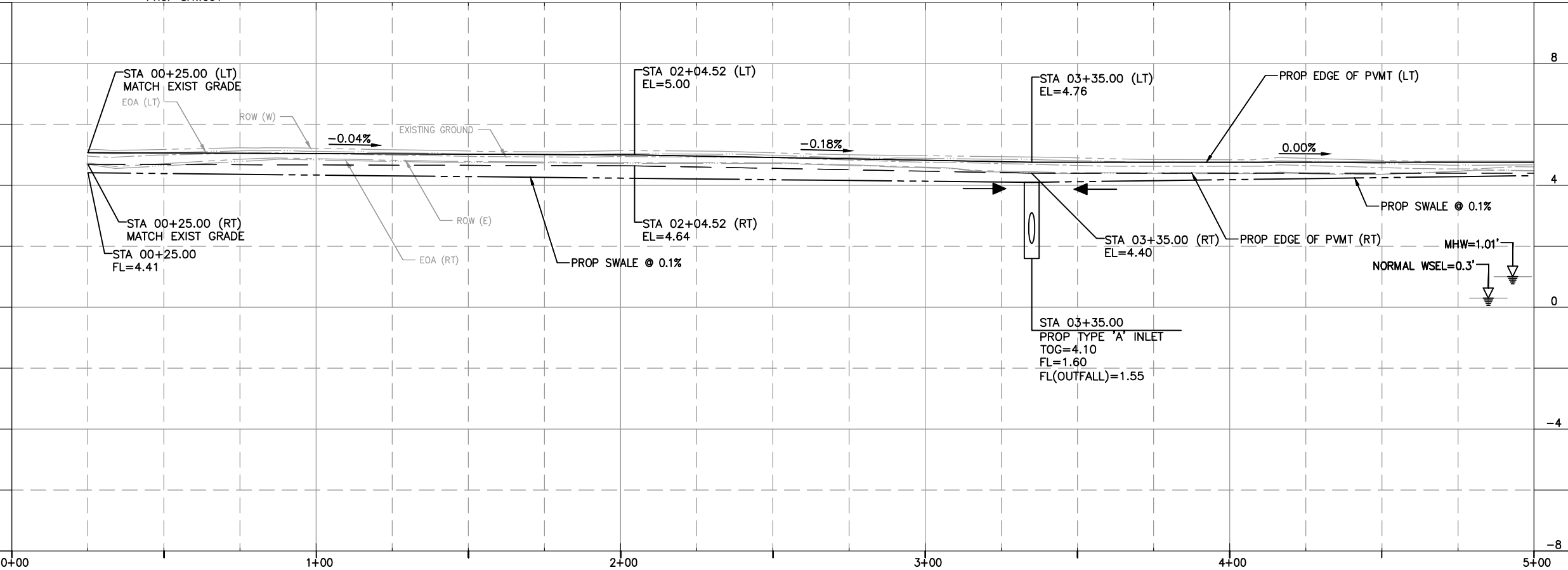

NO.	REVISIONS	DATE	NAME

**GALVESTON COUNTY
 ENGINEERING
 DEPARTMENT**



Zarinkel
 Engineering Services, Inc.
 817 Caroline St
 Houston, Texas
 Ph: 832.242.2426
 Fax: 832.242.2445
 Firm Reg. # F-004270

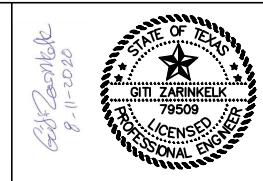

PROJECT TITLE: BLUE HERON DRIVE		PROJECT ID: BV01
DRAWN BY: FROM STA 00+00 TO STA 05+00	SHEET DESCRIPTION: ROADWAY SCHEMATICS PLAN	
CK'D BY:	DATE: 9/10/2020	
SCALE:	APPROVED BY:	SHEET NO: 6 / 30

FILE INFO: Z:\Galveston County\Blue Heron\04 CAD\06 - 12 C-001-001.dwg PLOTTED BY: James Gaibart DATE: Sep 10, 2020 3:44pm

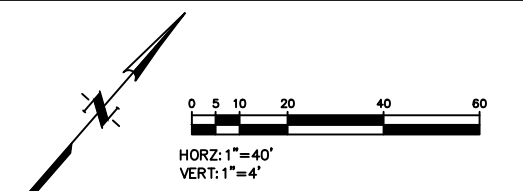
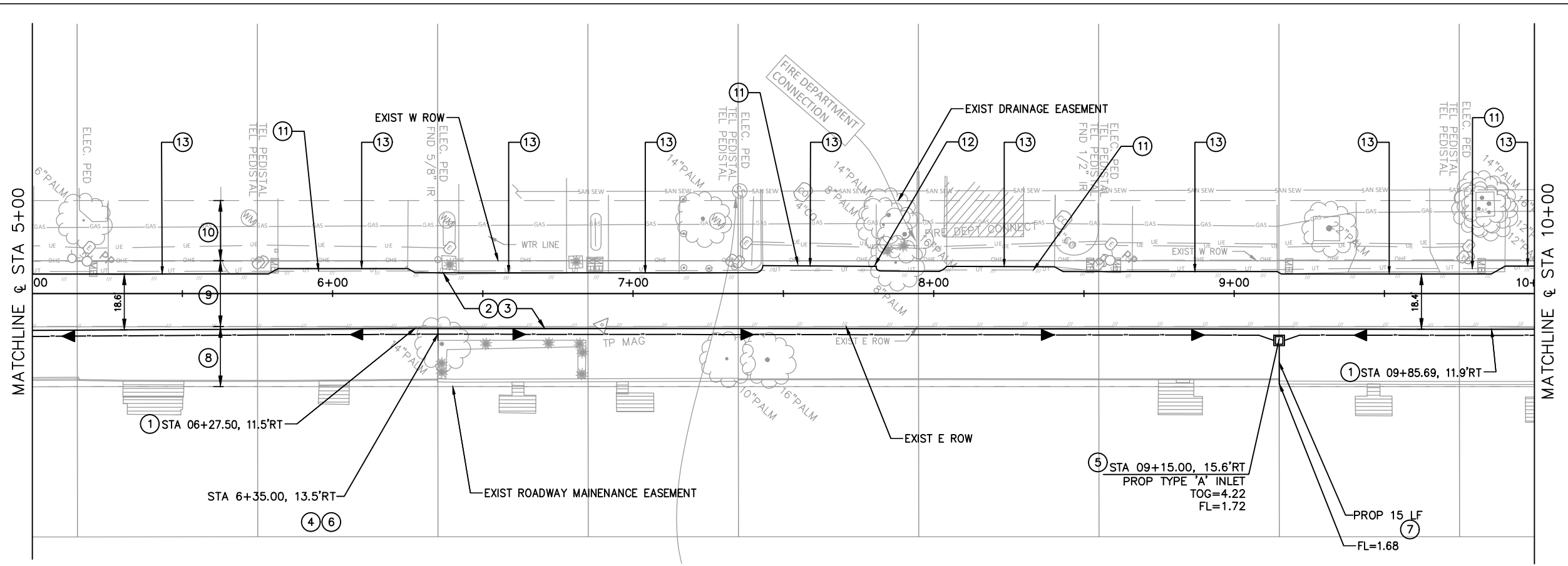

BENCHMARK
 DESIGNATION - 877 1486 C
 PID : D09997
 NAVD 88 GEOID 12A
 ELEVATION: = 11.9 FEET

TO REACH FROM THE INTERSECTION OF 51ST STREET AND US HIGHWAY 45 IN GALVESTON, TEXAS, PROCEED WEST ON US HIGHWAY 45 FOR 4.9 MI (7.9 KM) TO EXIT NUMBER 4 TOWARDS THE VILLAGE OF TIKI ISLAND. PROCEED 0.3 MI (0.5KM) AND TURN RIGHT ONTO VIRGINIA POINT ROAD. CONTINUE 0.3 MI ON VIRGINIA POINT ROAD BEARING RIGHT WHEN IT DEVERTS TO CROSS UNDER TO OLD RAILROAD BRIDGE TO THE MARK ON YOUR LEFT. THE BENCH MARK IS LOCATED 26.41 FEET (8.0 M) SOUTHWEST OF THE WESTERN MOST CORNER OF A CONCRETE WALL. 45 FEET (13.7 M) NORTHEAST OF THE NORTHERN MOST RAIL OF A RAILROAD TRACK. 94 FEET (28.7 M) NORTHEAST OF OLD HIGHWAY 75.

- NOTE:**
- ① PROPOSED EDGE OF PAVEMENT AT PGL.
 - ② SAWCUT, REMOVE AND DISPOSE/RECYCLE EXISTING PAVEMENT WITH SUBGRADE.
 - ③ PROPOSED 3-INCH HMAC SURFACE COURSE OVER 9-INCH COLD-IN-PLACE RECYCLED BASE.
 - ④ BEGIN PROPOSED SWALE.
 - ⑤ PROPOSED TYPE 'A' INLET.
 - ⑥ END PROPOSED SWALE.
 - ⑦ 12" HDPE @ 0.25%.
 - ⑧ 20' WIDE EXISTING ROAD MAINTENANCE EASEMENT.
 - ⑨ 22' WIDE EXISING ROW.
 - ⑩ 20' WIDE EXISTING DRAINAGE EASEMENT.
 - ⑪ PUC - POTENTIAL UTILITY CONFLICT.
 - ⑫ IMPLEMENT TREE PROTECTION.
 - ⑬ FINISHED PROPOSED GRADE TO EDGE OF DRIVEWAY.

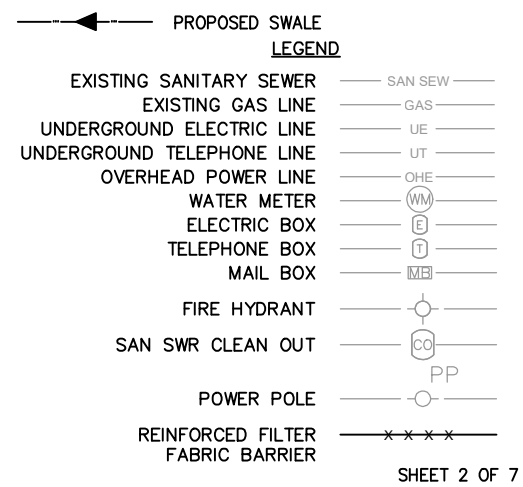
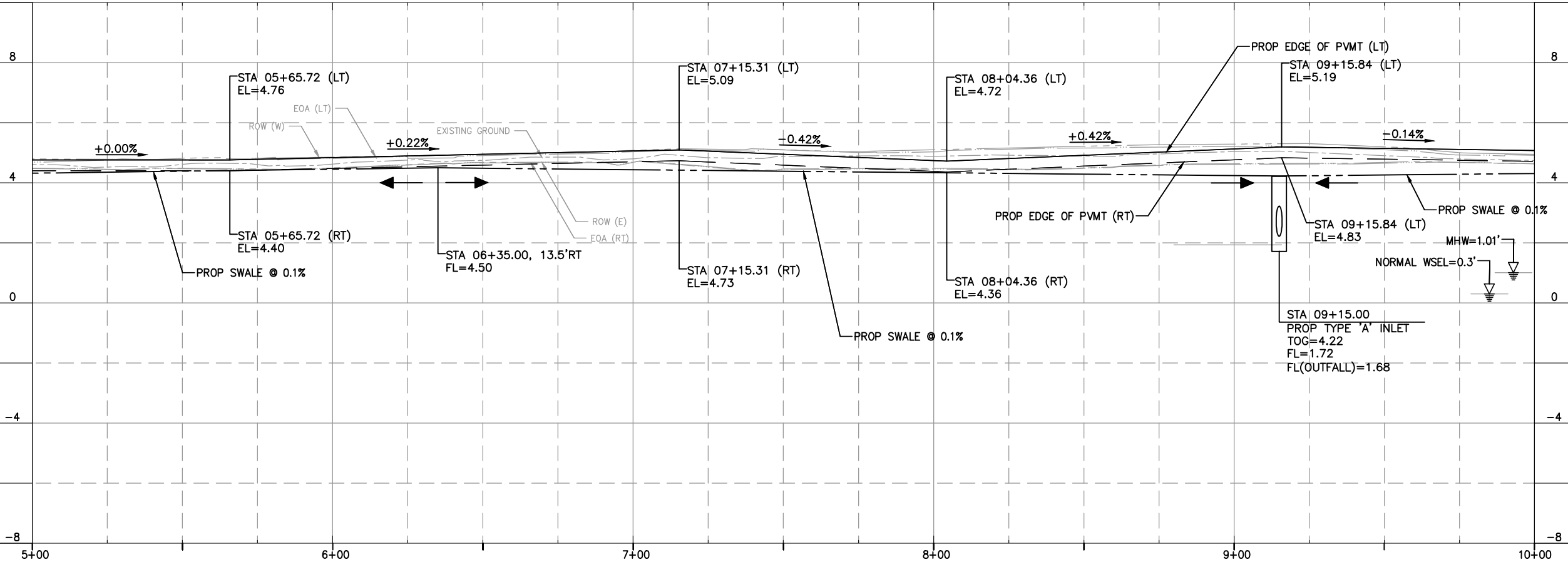

NO.	REVISIONS	DATE	NAME

**GALVESTON COUNTY
 ENGINEERING
 DEPARTMENT**



Zarinkel
 Engineering Services, Inc.
 817 Caroline St
 Houston, Texas
 Ph: 832.242.2426
 Fax: 832.242.2445
 Firm Reg. # F-004270

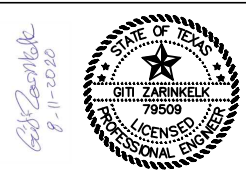

PROJECT TITLE: BLUE HERON DRIVE		PROJECT ID: BV01
DRAWN BY: FROM STA 05+00 TO STA 10+00	SHEET DESCRIPTION: ROADWAY SCHEMATICS PLAN	
CK'D BY:	SHEET NO: 7 / 30	
SCALE:	APPROVED BY:	DATE: 9/10/2020

FILE INFO: Z:\Galveston County\Blue Heron\04 CAD\06 - 12 C-001-001.dwg PLOTTED BY: James Gaibart DATE: Sep 10, 2020 3:45pm

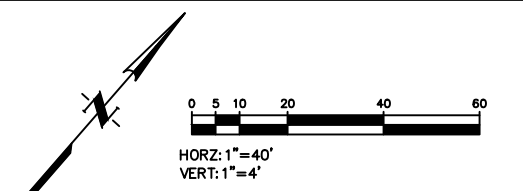
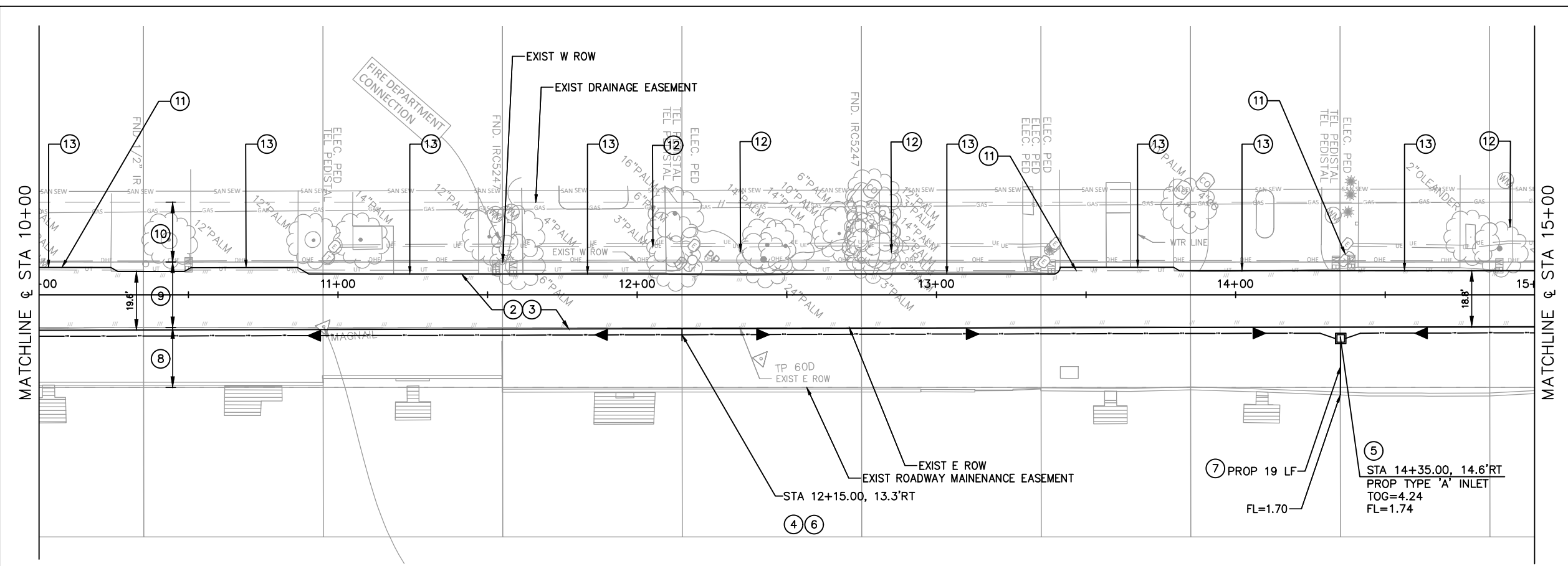

BENCHMARK
 DESIGNATION - 877 1486 C
 PID : D09997
 NAVD 88 GEOID 12A
 ELEVATION: = 11.9 FEET

TO REACH FROM THE INTERSECTION OF 51ST STREET AND US HIGHWAY 45 IN GALVESTON, TEXAS, PROCEED WEST ON US HIGHWAY 45 FOR 4.9 MI (7.9 KM) TO EXIT NUMBER 4 TOWARDS THE VILLAGE OF TIKI ISLAND. PROCEED 0.3 MI (0.5KM) AND TURN RIGHT ONTO VIRGINIA POINT ROAD. CONTINUE 0.3 MI ON VIRGINIA POINT ROAD BEARING RIGHT WHEN IT DEVERTS TO CROSS UNDER TO OLD RAILROAD BRIDGE TO THE MARK ON YOUR LEFT. THE BENCH MARK IS LOCATED 26.41 FEET (8.0 M) SOUTHWEST OF THE WESTERN MOST CORNER OF A CONCRETE WALL. 45 FEET (13.7 M) NORTHEAST OF THE NORTHERN MOST RAIL OF A RAILROAD TRACK. 94 FEET (28.7 M) NORTHEAST OF OLD HIGHWAY 75.

- NOTE:**
- ① PROPOSED EDGE OF PAVEMENT AT PGL.
 - ② SAWCUT, REMOVE AND DISPOSE/RECYCLE EXISTING PAVEMENT WITH SUBGRADE.
 - ③ PROPOSED 3-INCH HMAC SURFACE COURSE OVER 9-INCH COLD-IN-PLACE RECYCLED BASE.
 - ④ BEGIN PROPOSED SWALE.
 - ⑤ PROPOSED TYPE 'A' INLET.
 - ⑥ END PROPOSED SWALE.
 - ⑦ 12" HDPE @ 0.25%
 - ⑧ 20' WIDE EXISTING ROAD MAINTENANCE EASEMENT.
 - ⑨ 22' WIDE EXISING ROW.
 - ⑩ 20' WIDE EXISTING DRAINAGE EASEMENT.
 - ⑪ PUC - POTENTIAL UTILITY CONFLICT.
 - ⑫ IMPLEMENT TREE PROTECTION.
 - ⑬ FINISHED PROPOSED GRADE TO EDGE OF DRIVEWAY.

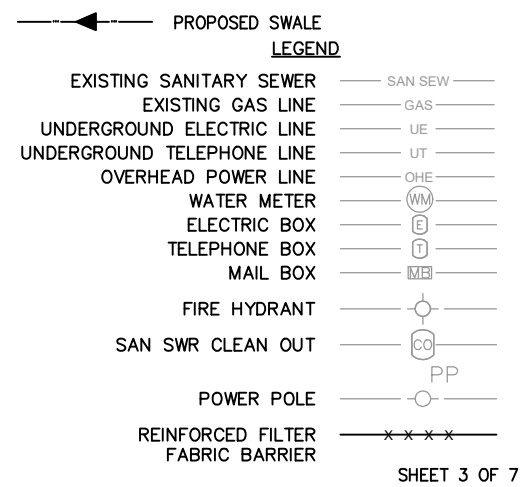
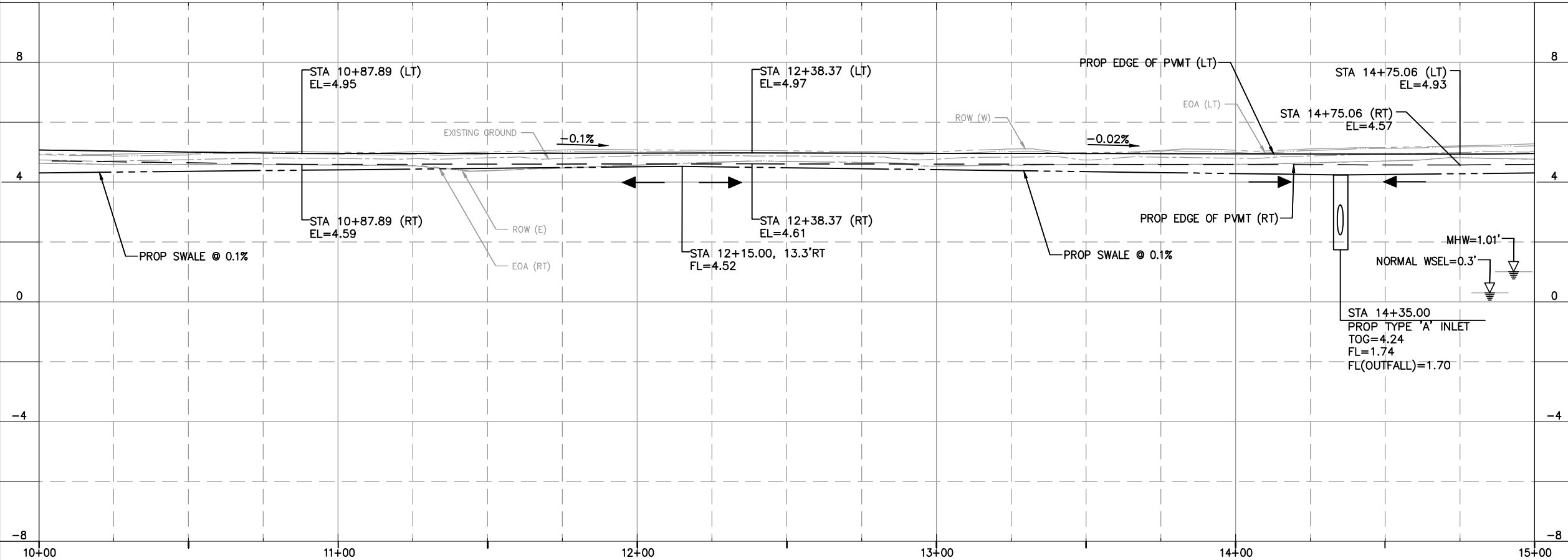

NO.	REVISIONS	DATE	NAME

**GALVESTON COUNTY
 ENGINEERING
 DEPARTMENT**



Zarinkel
 Engineering Services, Inc.
 817 Caroline St
 Houston, Texas
 Ph: 832.242.2426
 Fax: 832.242.2445
 Firm Reg. # F-004270

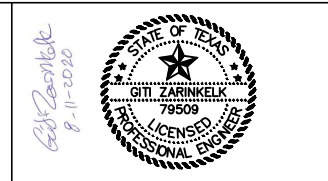

PROJECT TITLE: BLUE HERON DRIVE		PROJECT ID: BV01
DRAWN BY: FROM STA 10+00 TO STA 15+00	SHEET DESCRIPTION: ROADWAY SCHEMATICS PLAN	
CK'D BY:	SHEET NO: 8 / 30	
DATE: 9/10/2020	APPROVED BY:	

FILE INFO: Z:\Galveston County\Blue Heron\04 CAD\06 - 12 C-001-001.dwg PLOTTED BY: James Gaibart DATE: Sep 10, 2020 3:45pm

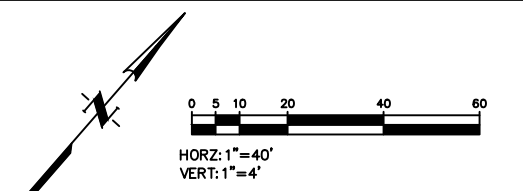
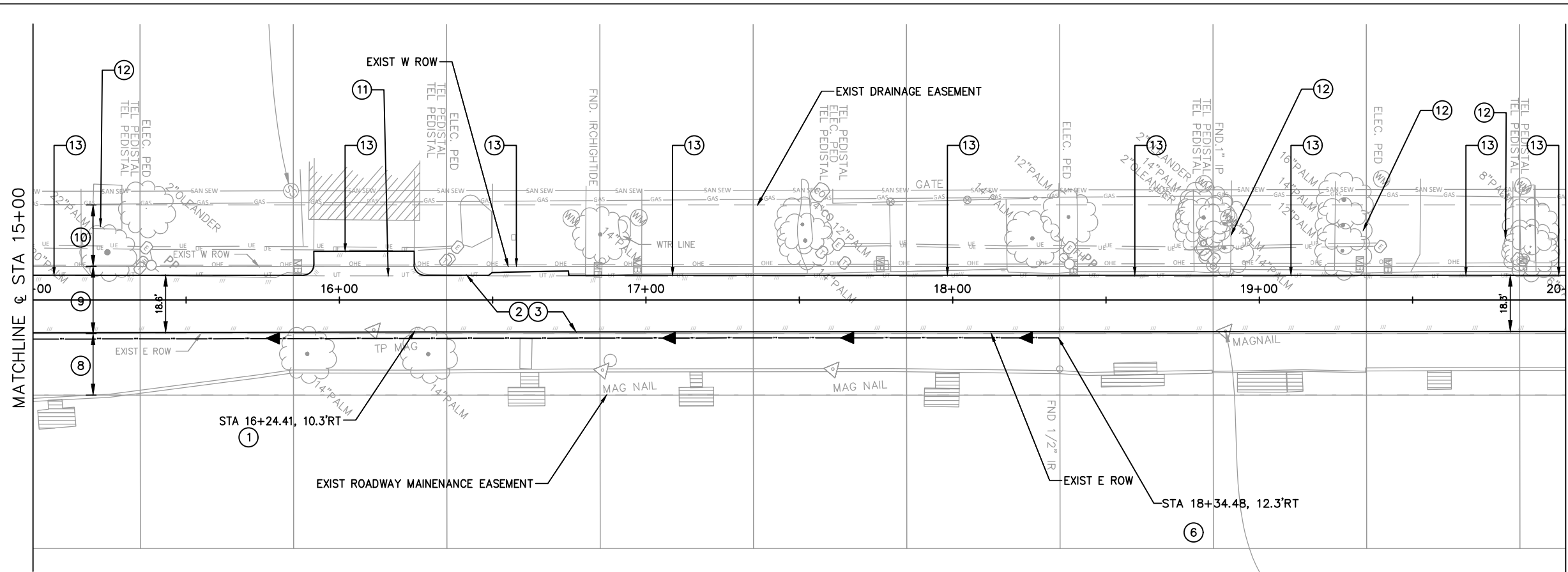

BENCHMARK
 DESIGNATION - 877 1486 C
 PID : D09997
 NAVD 88 GEOID 12A
 ELEVATION: = 11.9 FEET

TO REACH FROM THE INTERSECTION OF 51ST STREET AND US HIGHWAY 45 IN GALVESTON, TEXAS, PROCEED WEST ON US HIGHWAY 45 FOR 4.9 MI (7.9 KM) TO EXIT NUMBER 4 TOWARDS THE VILLAGE OF TIKI ISLAND. PROCEED 0.3 MI (0.5KM) AND TURN RIGHT ONTO VIRGINIA POINT ROAD. CONTINUE 0.3 MI ON VIRGINIA POINT ROAD BEARING RIGHT WHEN IT DEVERTS TO CROSS UNDER TO OLD RAILROAD BRIDGE TO THE MARK ON YOUR LEFT. THE BENCH MARK IS LOCATED 26.41 FEET (8.0 M) SOUTHWEST OF THE WESTERN MOST CORNER OF A CONCRETE WALL. 45 FEET (13.7 M) NORTHEAST OF THE NORTHERN MOST RAIL OF A RAILROAD TRACK. 94 FEET (28.7 M) NORTHEAST OF OLD HIGHWAY 75.

- NOTE:**
- ① PROPOSED EDGE OF PAVEMENT AT PGL.
 - ② SAWCUT, REMOVE AND DISPOSE/RECYCLE EXISTING PAVEMENT WITH SUBGRADE.
 - ③ PROPOSED 3-INCH HMAC SURFACE COURSE OVER 9-INCH COLD-IN-PLACE RECYCLED BASE.
 - ④ BEGIN PROPOSED SWALE.
 - ⑤ PROPOSED TYPE 'A' INLET.
 - ⑥ END PROPOSED SWALE.
 - ⑦ 12" HDPE @ 0.25%.
 - ⑧ 20' WIDE EXISTING ROAD MAINTENANCE EASEMENT.
 - ⑨ 22' WIDE EXISING ROW.
 - ⑩ 20' WIDE EXISTING DRAINAGE EASEMENT.
 - ⑪ PUC - POTENTIAL UTILITY CONFLICT.
 - ⑫ IMPLEMENT TREE PROTECTION.
 - ⑬ FINISHED PROPOSED GRADE TO EDGE OF DRIVEWAY.

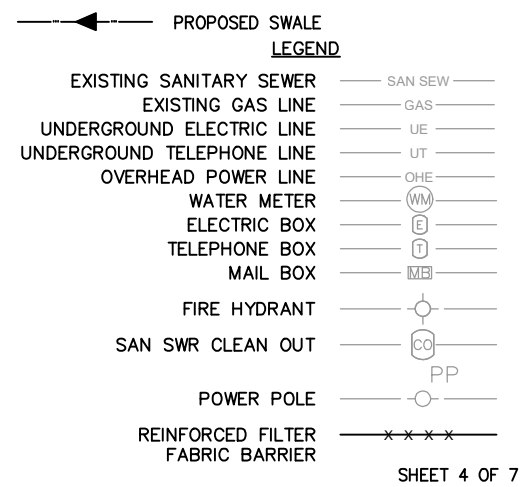
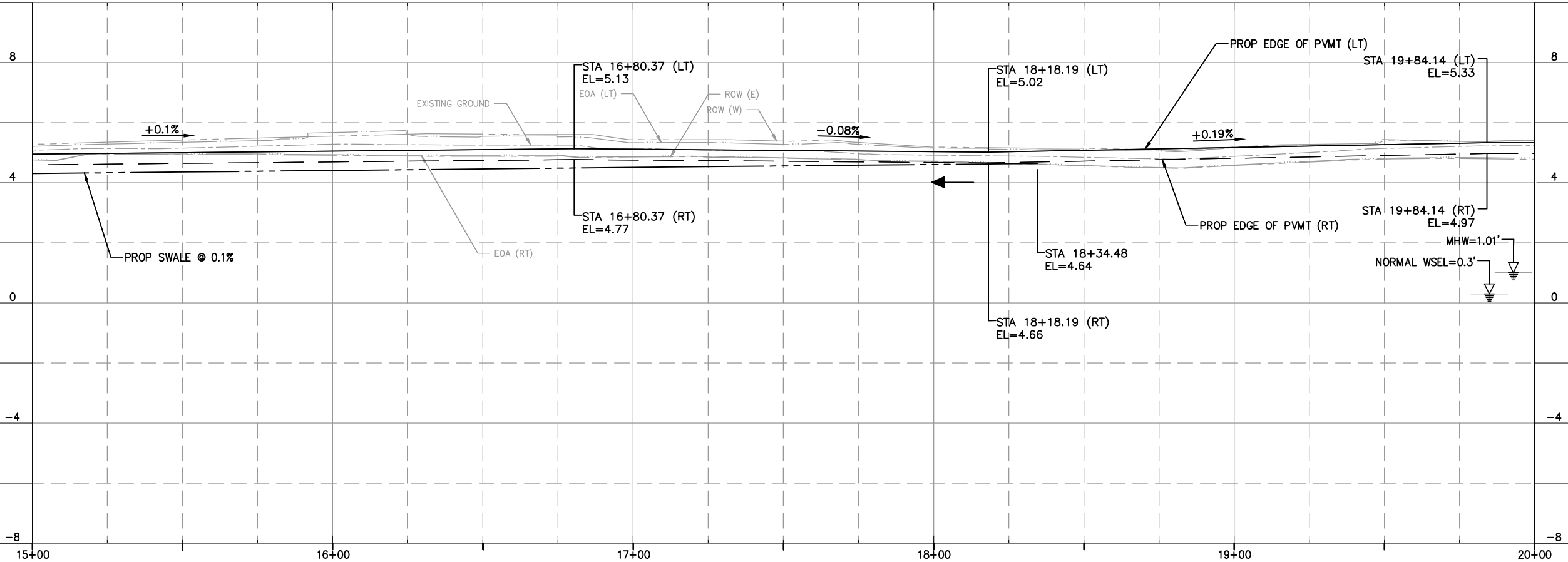

NO.	REVISIONS	DATE	NAME

**GALVESTON COUNTY
 ENGINEERING
 DEPARTMENT**



Zarinkel
 Engineering Services, Inc.
 817 Caroline St
 Houston, Texas
 Ph: 832.242.2426
 Fax: 832.242.2445
 Firm Reg. # F-004270



PROJECT TITLE: BLUE HERON DRIVE		PROJECT ID: BV01
DRAWN BY: FROM STA 15+00 TO STA 20+00	SHEET DESCRIPTION: ROADWAY SCHEMATICS PLAN	
CK'D BY:	SHEET NO: 9 / 30	
DATE: 9/10/2020	APPROVED BY:	

FILE INFO: Z:\Galveston County\Blue Heron\04 CAD\06 - 12 C-001-001.dwg PLOTTED BY: James Gaibart DATE: Sep 10, 2020 3:45pm

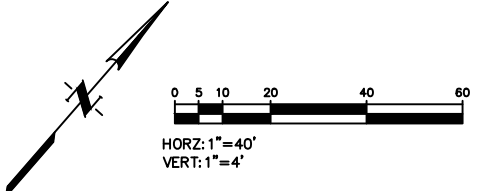
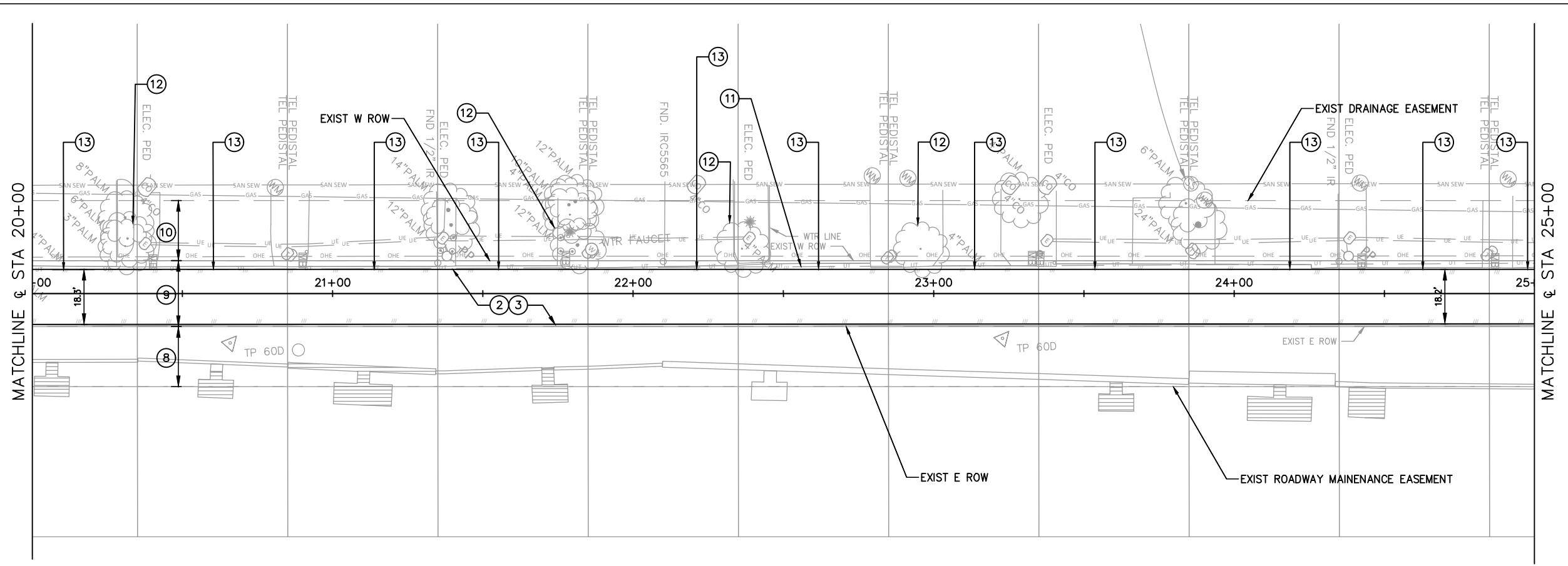

BENCHMARK
 DESIGNATION - 877 1486 C
 PID : D09997
 NAVD 88 GEOID 12A
 ELEVATION: = 11.9 FEET

TO REACH FROM THE INTERSECTION OF 51ST STREET AND US HIGHWAY 45 IN GALVESTON, TEXAS, PROCEED WEST ON US HIGHWAY 45 FOR 4.9 MI (7.9 KM) TO EXIT NUMBER 4 TOWARDS THE VILLAGE OF TIKI ISLAND. PROCEED 0.3 MI (0.5KM) AND TURN RIGHT ONTO VIRGINIA POINT ROAD. CONTINUE 0.3 MI ON VIRGINIA POINT ROAD BEARING RIGHT WHEN IT DEVERTS TO CROSS UNDER TO OLD RAILROAD BRIDGE TO THE MARK ON YOUR LEFT. THE BENCH MARK IS LOCATED 26.41 FEET (8.0 M) SOUTHWEST OF THE WESTERN MOST CORNER OF A CONCRETE WALL. 45 FEET (13.7 M) NORTHEAST OF THE NORTHERN MOST RAIL OF A RAILROAD TRACK. 94 FEET (28.7 M) NORTHEAST OF OLD HIGHWAY 75.

- NOTE:**
- ① PROPOSED EDGE OF PAVEMENT AT PGL.
 - ② SAWCUT, REMOVE AND DISPOSE/RECYCLE EXISTING PAVEMENT WITH SUBGRADE.
 - ③ PROPOSED 3-INCH HMAC SURFACE COURSE OVER 9-INCH COLD-IN-PLACE RECYCLED BASE.
 - ④ BEGIN PROPOSED SWALE.
 - ⑤ PROPOSED TYPE 'A' INLET.
 - ⑥ END PROPOSED SWALE.
 - ⑦ 12" HDPE @ 0.25%
 - ⑧ 20' WIDE EXISTING ROAD MAINTENANCE EASEMENT.
 - ⑨ 22' WIDE EXISING ROW.
 - ⑩ 20' WIDE EXISTING DRAINAGE EASEMENT.
 - ⑪ PUC - POTENTIAL UTILITY CONFLICT.
 - ⑫ IMPLEMENT TREE PROTECTION.
 - ⑬ FINISHED PROPOSED GRADE TO EDGE OF DRIVEWAY.

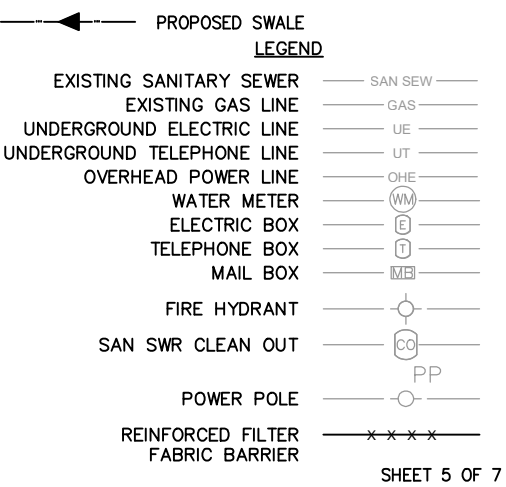
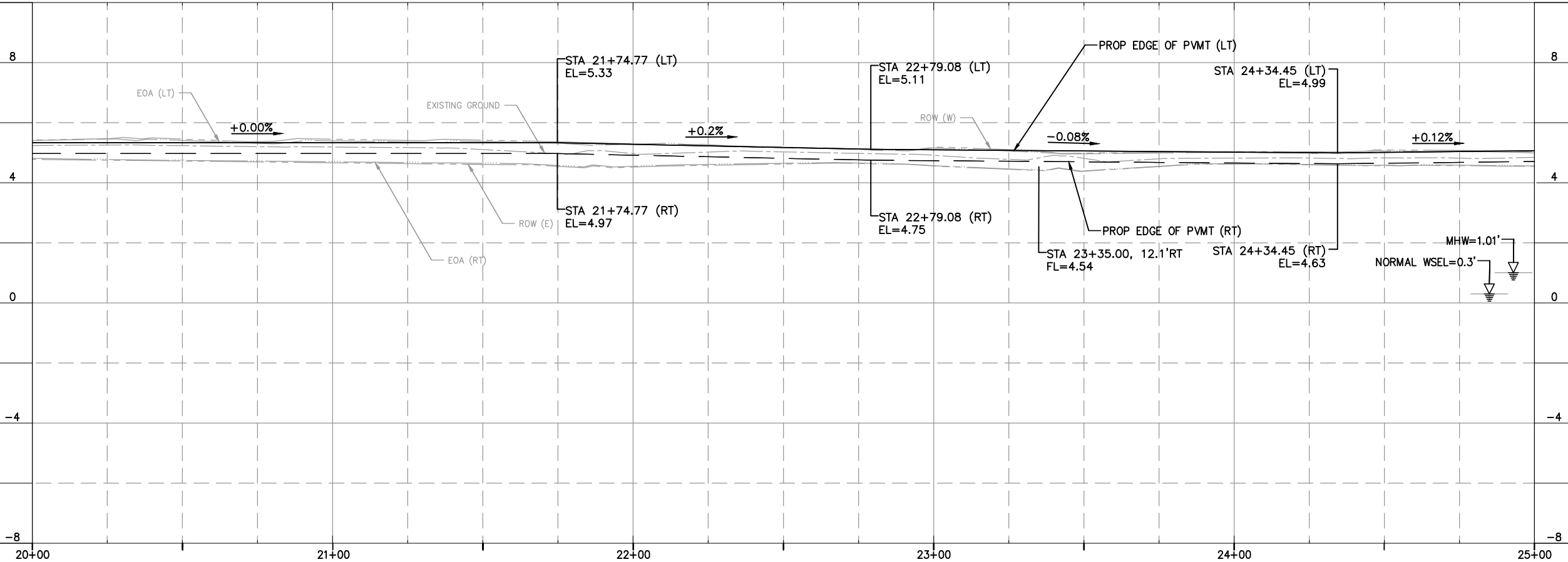

NO.	REVISIONS	DATE	NAME

**GALVESTON COUNTY
 ENGINEERING
 DEPARTMENT**



Zarinkel
 Engineering Services, Inc.
 817 Caroline St
 Houston, Texas
 Ph: 832.242.2426
 Fax: 832.242.2445
 Firm Reg. # F-004270

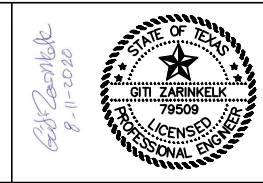

PROJECT TITLE: BLUE HERON DRIVE		PROJECT ID: BV01
DRAWN BY: FROM STA 20+00 TO STA 25+00	SHEET DESCRIPTION: ROADWAY SCHEMATICS PLAN	
CK'D BY:	APPROVED BY:	
SCALE:	DATE: 9/10/2020	
DATE: 9/10/2020	SHEET NO: 10 / 30	

FILE INFO: Z:\Galveston County\Blue Heron\04 CAD\06 - 12 C-001-001.dwg PLOTTED BY: James Gaibart DATE: Sep 10, 2020 3:45pm

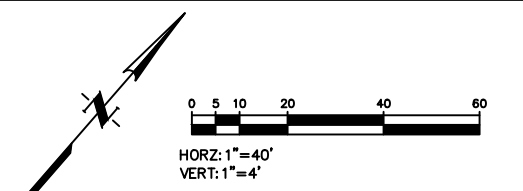
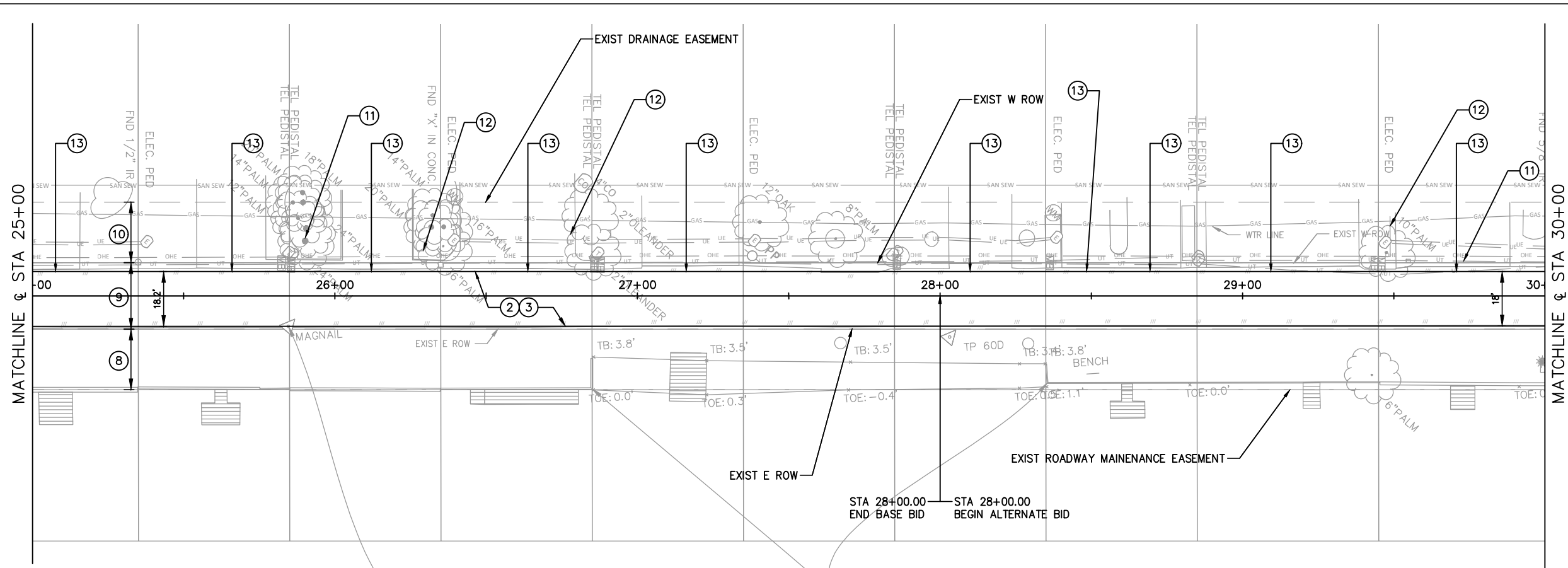

BENCHMARK
 DESIGNATION - 877 1486 C
 PID : D09997
 NAVD 88 GEOID 12A
 ELEVATION = 11.9 FEET

TO REACH FROM THE INTERSECTION OF 51ST STREET AND US HIGHWAY 45 IN GALVESTON, TEXAS, PROCEED WEST ON US HIGHWAY 45 FOR 4.9 MI (7.9 KM) TO EXIT NUMBER 4 TOWARDS THE VILLAGE OF TIKI ISLAND. PROCEED 0.3 MI (0.5KM) AND TURN RIGHT ONTO VIRGINIA POINT ROAD. CONTINUE 0.3 MI ON VIRGINIA POINT ROAD BEARING RIGHT WHEN IT DEVERTS TO CROSS UNDER TO OLD RAILROAD BRIDGE TO THE MARK ON YOUR LEFT. THE BENCH MARK IS LOCATED 26.41 FEET (8.0 M) SOUTHWEST OF THE WESTERN MOST CORNER OF A CONCRETE WALL. 45 FEET (13.7 M) NORTHEAST OF THE NORTHERN MOST RAIL OF A RAILROAD TRACK. 94 FEET (28.7 M) NORTHEAST OF OLD HIGHWAY 75.

- NOTE:**
- ① PROPOSED EDGE OF PAVEMENT AT PGL.
 - ② SAWCUT, REMOVE AND DISPOSE/RECYCLE EXISTING PAVEMENT WITH SUBGRADE.
 - ③ PROPOSED 3-INCH HMAC SURFACE COURSE OVER 9-INCH COLD-IN-PLACE RECYCLED BASE.
 - ④ BEGIN PROPOSED SWALE.
 - ⑤ PROPOSED TYPE 'A' INLET.
 - ⑥ END PROPOSED SWALE.
 - ⑦ 12" HDPE @ 0.25%
 - ⑧ 20' WIDE EXISTING ROAD MAINTENANCE EASEMENT.
 - ⑨ 22' WIDE EXISING ROW.
 - ⑩ 20' WIDE EXISTING DRAINAGE EASEMENT.
 - ⑪ PUC - POTENTIAL UTILITY CONFLICT.
 - ⑫ IMPLEMENT TREE PROTECTION.
 - ⑬ FINISHED PROPOSED GRADE TO EDGE OF DRIVEWAY.

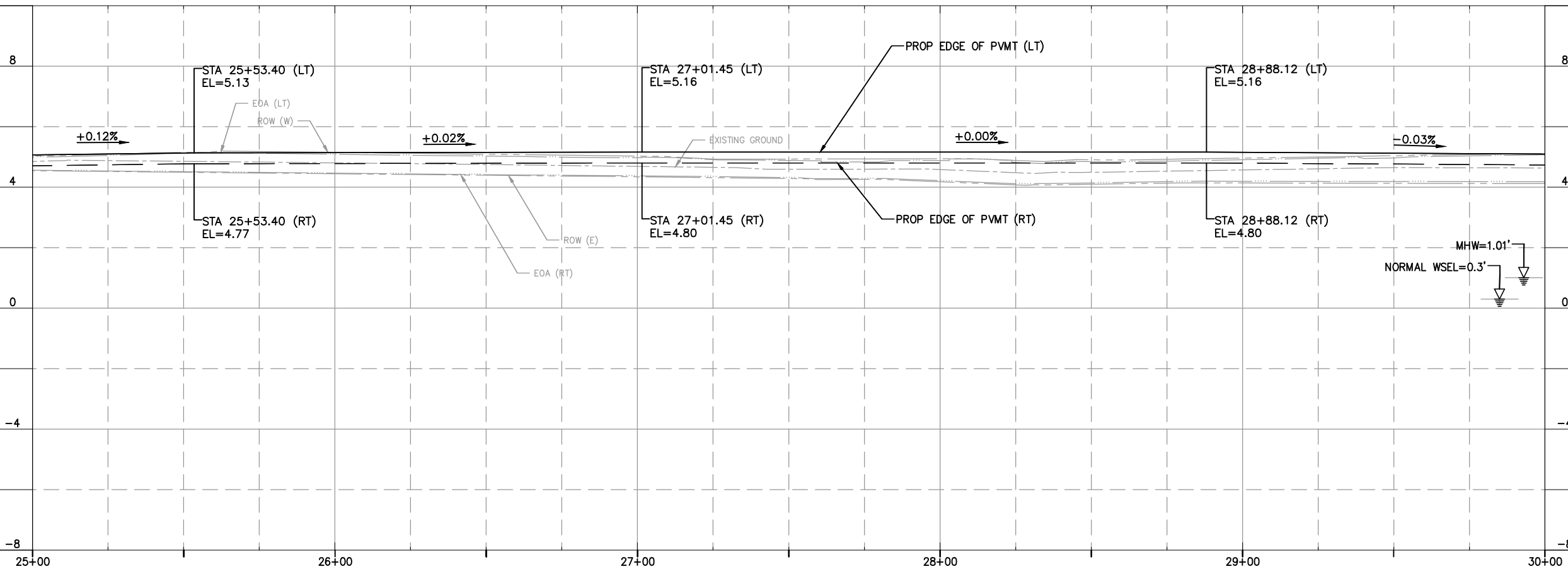

LEGEND

- ← PROPOSED SWALE
- EXISTING SANITARY SEWER — SAN SEW —
- EXISTING GAS LINE — GAS —
- UNDERGROUND ELECTRIC LINE — UE —
- UNDERGROUND TELEPHONE LINE — UT —
- OVERHEAD POWER LINE — OHE —
- WATER METER (WM)
- ELECTRIC BOX (E)
- TELEPHONE BOX (T)
- MAIL BOX (MB)
- FIRE HYDRANT (FH)
- SAN SWR CLEAN OUT (CC)
- POWER POLE (PP)
- REINFORCED FILTER FABRIC BARRIER (XXXX)

NO.	REVISIONS	DATE	NAME

**GALVESTON COUNTY
 ENGINEERING
 DEPARTMENT**



Zarinkel
 Engineering Services, Inc.
 817 Caroline St
 Houston, Texas
 Ph: 832.242.2426
 Fax: 832.242.2445
 Firm Reg. # F-004270



PROJECT TITLE: BLUE HERON DRIVE		PROJECT ID: BV01
DRAWN BY: FROM STA 25+00 TO STA 30+00	SHEET DESCRIPTION: ROADWAY SCHEMATICS PLAN	
CK'D BY:	DATE: 9/10/2020	
SCALE:	APPROVED BY:	SHEET NO: 11 / 30

FILE INFO: Z:\Galveston County\Blue Heron\04 CAD\06 - 12 C-001-001.dwg PLOTTED BY: James Gaibart DATE: Sep 10, 2020 3:45pm

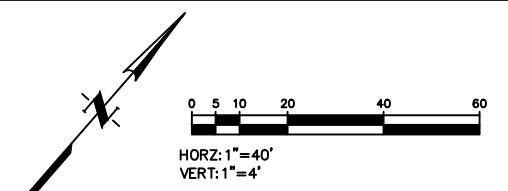
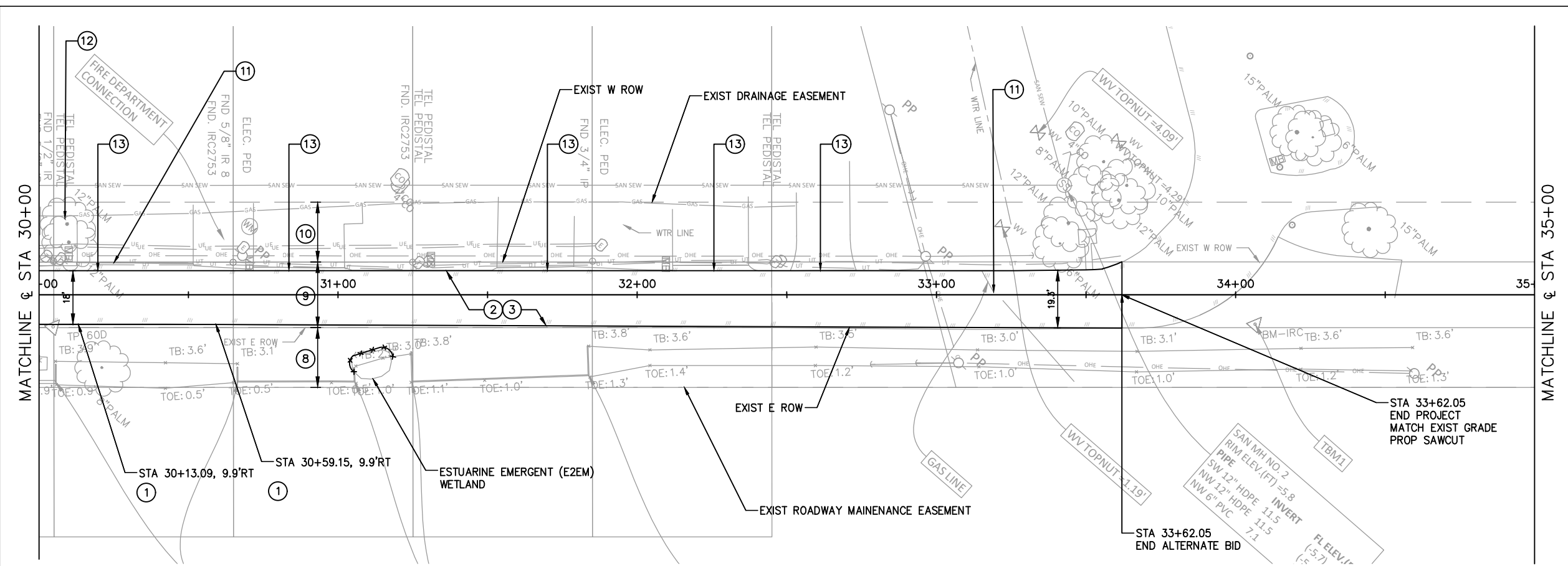

BENCHMARK
 DESIGNATION - 877 1486 C
 PID : D09997
 NAVD 88 GEOID 12A
 ELEVATION: = 11.9 FEET

TO REACH FROM THE INTERSECTION OF 51ST STREET AND US HIGHWAY 45 IN GALVESTON, TEXAS, PROCEED WEST ON US HIGHWAY 45 FOR 4.9 MI (7.9 KM) TO EXIT NUMBER 4 TOWARDS THE VILLAGE OF TIKI ISLAND. PROCEED 0.3 MI (0.5KM) AND TURN RIGHT ONTO VIRGINIA POINT ROAD. CONTINUE 0.3 MI ON VIRGINIA POINT ROAD BEARING RIGHT WHEN IT DEVERTS TO CROSS UNDER TO OLD RAILROAD BRIDGE TO THE MARK ON YOUR LEFT. THE BENCH MARK IS LOCATED 26.41 FEET (8.0 M) SOUTHWEST OF THE WESTERN MOST CORNER OF A CONCRETE WALL. 45 FEET (13.7 M) NORTHEAST OF THE NORTHERN MOST RAIL OF A RAILROAD TRACK. 94 FEET (28.7 M) NORTHEAST OF OLD HIGHWAY 75.

- NOTE:**
- ① PROPOSED EDGE OF PAVEMENT AT PGL.
 - ② SAWCUT, REMOVE AND DISPOSE/RECYCLE EXISTING PAVEMENT WITH SUBGRADE.
 - ③ PROPOSED 3-INCH HMAC SURFACE COURSE OVER 9-INCH COLD-IN-PLACE RECYCLED BASE.
 - ④ BEGIN PROPOSED SWALE.
 - ⑤ PROPOSED TYPE 'A' INLET.
 - ⑥ END PROPOSED SWALE.
 - ⑦ 12" HDPE @ 0.25%.
 - ⑧ 20' WIDE EXISTING ROAD MAINTENANCE EASEMENT.
 - ⑨ 22' WIDE EXISING ROW.
 - ⑩ 20' WIDE EXISTING DRAINAGE EASEMENT.
 - ⑪ PUC - POTENTIAL UTILITY CONFLICT.
 - ⑫ IMPLEMENT TREE PROTECTION.
 - ⑬ FINISHED PROPOSED GRADE TO EDGE OF DRIVEWAY.

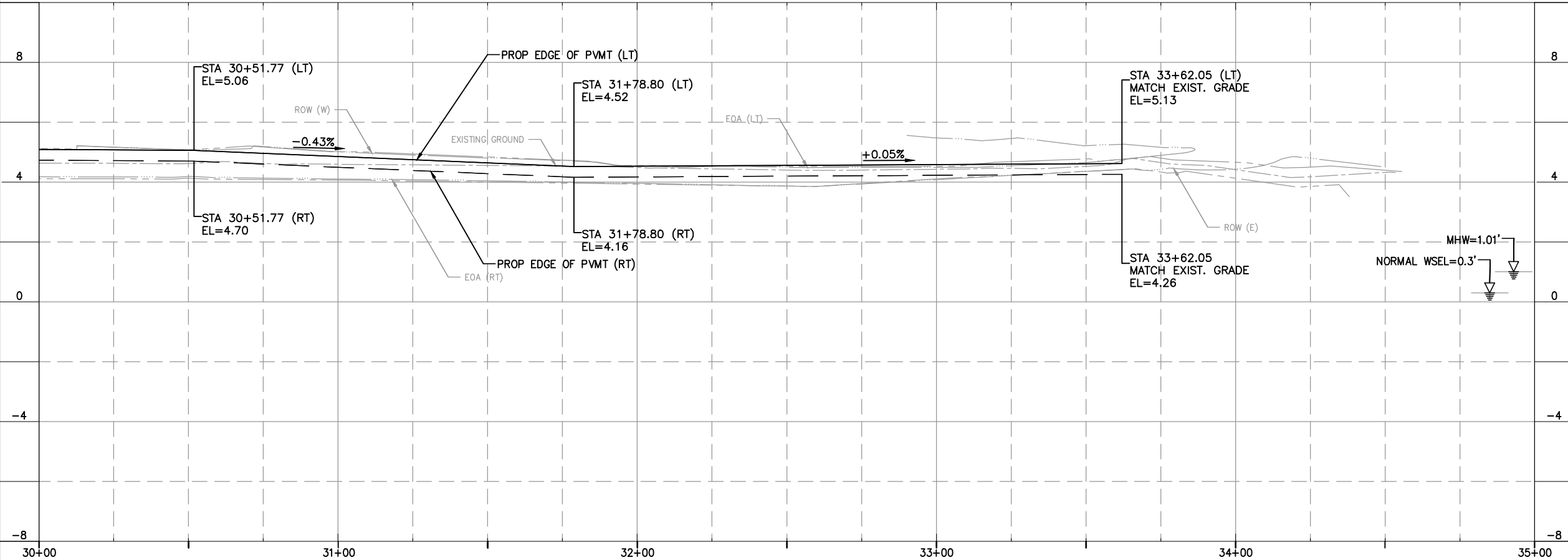

LEGEND

EXISTING SANITARY SEWER	SAN SEW
EXISTING GAS LINE	GAS
UNDERGROUND ELECTRIC LINE	UE
UNDERGROUND TELEPHONE LINE	UT
OVERHEAD POWER LINE	OHE
WATER METER	WM
ELECTRIC BOX	EB
TELEPHONE BOX	TB
MAIL BOX	MB
FIRE HYDRANT	○
SAN SWR CLEAN OUT	○
POWER POLE	○
REINFORCED FILTER FABRIC BARRIER	***

NO.	REVISIONS	DATE	NAME

**GALVESTON COUNTY
 ENGINEERING
 DEPARTMENT**



Zarinkel
 Engineering Services, Inc.

817 Caroline St
 Houston, Texas
 Ph: 832.242.2426
 Fax: 832.242.2445
 Firm Reg. # F-004270

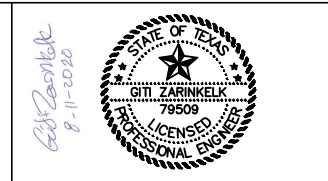

PROJECT TITLE:	BLUE HERON DRIVE	
DRAWN BY:	FROM STA 30+00 TO STA 35+00	PROJECT ID:
CK'D BY:	SHEET DESCRIPTION: ROADWAY SCHEMATICS PLAN	BV01
SCALE:		SHEET NO:
DATE:	APPROVED BY:	12 / 30
9/10/2020		

FILE INFO: Z:\Galveston County\Blue Heron\04 CAD\13 - TYPE A INLET DETAILS.dwg PLOTTED BY: James Gaibort DATE: Sep 10, 2020 3:45pm

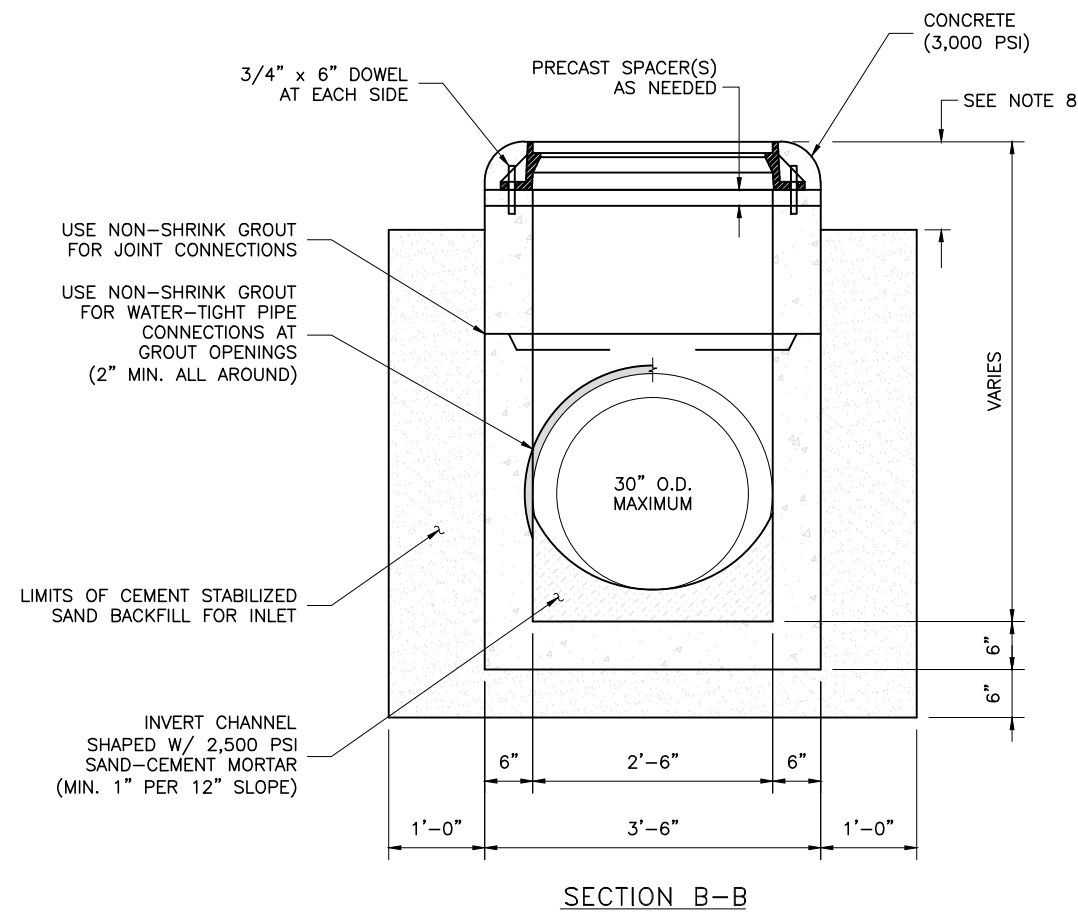
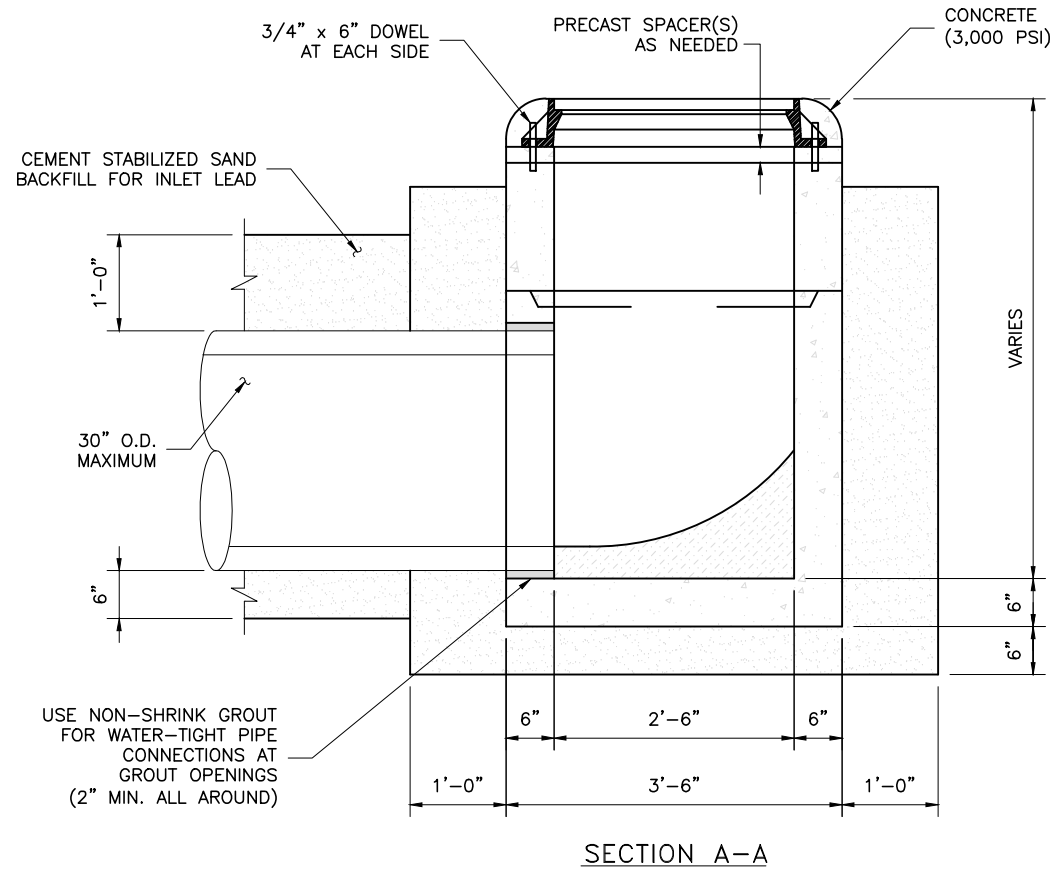
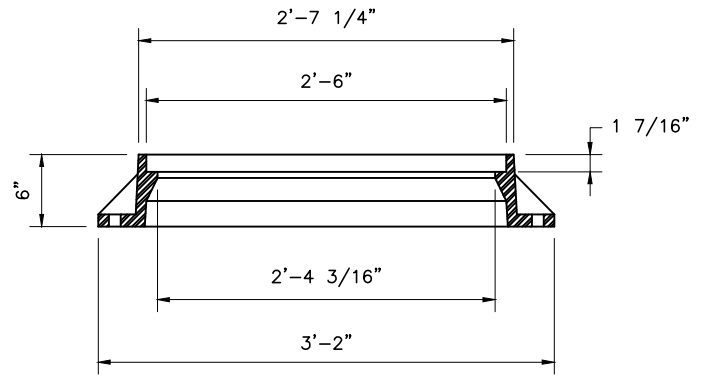
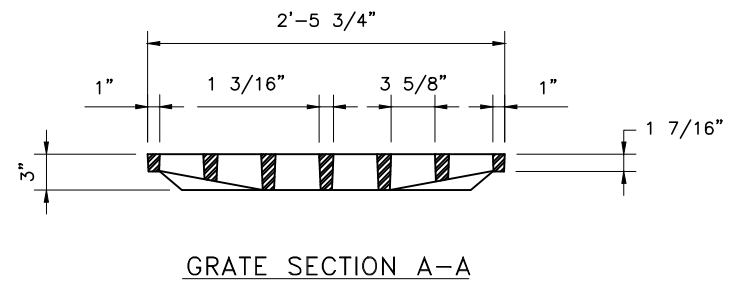
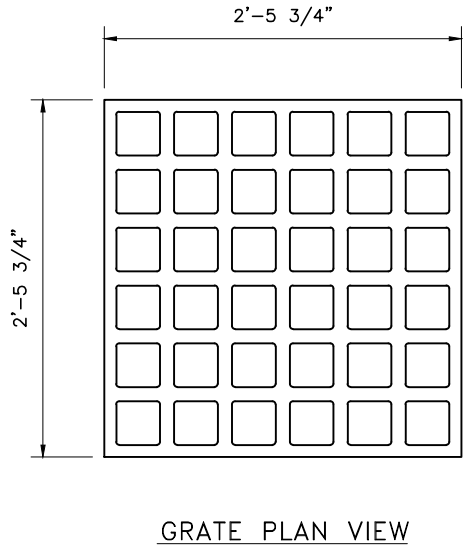
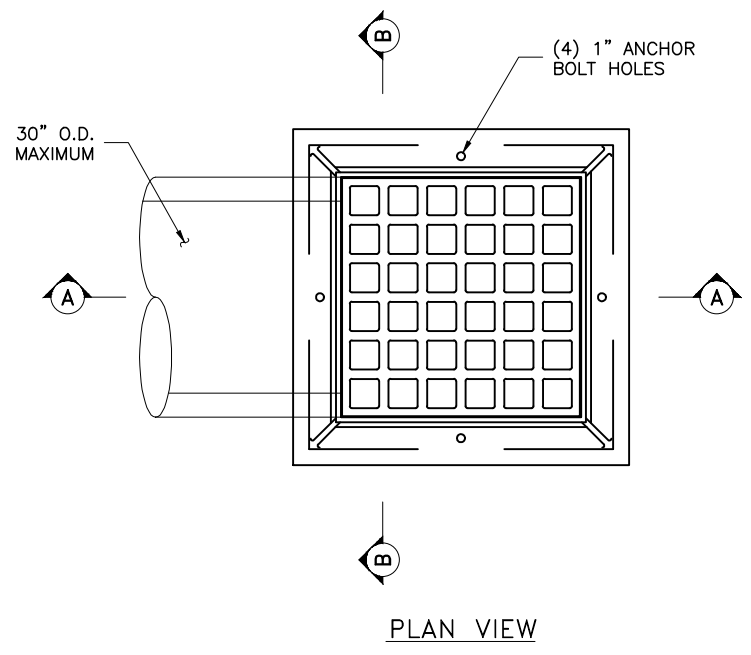

GENERAL NOTES:

1. CONSTRUCTION AND MATERIALS SHALL MEET REQUIREMENTS OF ITEM 472 "INLETS".
2. CONCRETE FOR INLET: MINIMUM 4,000 PSI IN 28 DAYS
3. PRECAST STRUCTURE TO MEET ASTM C913
4. FRAME AND GRATE SHALL BE EAST JORDAN IRON WORKS MODEL V-4880-1 (OPEN AREA 473 SQ. IN.) OR APPROVED EQUAL.
5. IF THE ENGINEER OF RECORD SPECIFIES A CAST-IN PLACE INLET, HE/SHE SHALL INCORPORATE A DETAILED DRAWING INTO THE CONTRACT DOCUMENTS. HOWEVER, IF THE CONTRACTOR ELECTS TO CONSTRUCT A CAST-IN PLACE INLET, THE CONTRACTOR WILL BE RESPONSIBLE FOR PROVIDING A DETAIL DRAWING.
6. SHOP DRAWINGS SHALL BE REQUIRED FOR PRECAST CONSTRUCTION OF INLET.
7. KNOCK-OUTS ARE NOT PERMISSIBLE FOR PRECAST CONSTRUCTION OF INLET.
8. CEMENT STABILIZED SAND SHALL EXTEND TO THE BOTTOM OF PAVEMENT OR SLOPE PAVING, OR 12 INCHES BELOW THE SURFACE IF INLET IS LOCATED IN AN UNPAVED AREA.

NO.	REVISIONS	DATE	NAME

**GALVESTON COUNTY
ENGINEERING
DEPARTMENT**



Zarinkel
Engineering Services, Inc.
817 Caroline St.
Houston, Texas
Ph: 832.242.2426
Fax: 832.242.2445
Firm Reg. # F-004270



PROJECT TITLE: BLUE HERON DRIVE		PROJECT ID: BV01
DRAWN BY:	SHEET DESCRIPTION: TYPE "A" INLET DETAILS	SHEET NO: 13 / 30
CK'D BY:	FOR MAXIMUM 30" O.D. PIPE	
DATE: 9/10/2020	APPROVED BY:	

02317-02

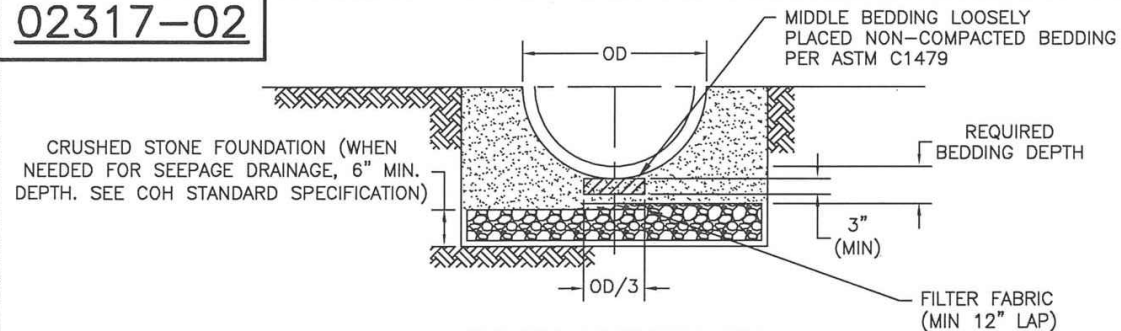

CROSS-SECTION OF CRUSHED STONE FOUNDATION

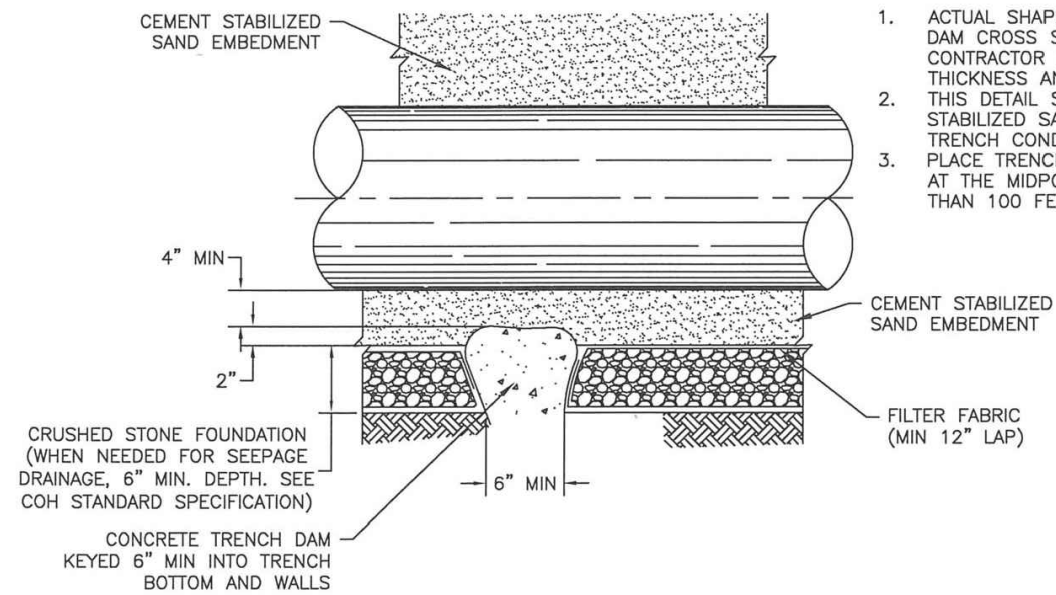

LONGITUDINAL SECTION ALONG PIPE ϕ AT FOUNDATION TRENCH DAM

SANITARY OR STORM SEWER CRUSHED STONE FOUNDATION FOR WET STABLE TRENCH NTS

NOTES:

1. ACTUAL SHAPE OF CONCRETE TRENCH DAM CROSS SECTION MAY BE DETERMINED BY CONTRACTOR IN FIELD, MEETING MINIMUM THICKNESS AND KEY DEPTH REQUIREMENTS.
2. THIS DETAIL SHALL BE USED WITH CEMENT STABILIZED SAND EMBEDMENT, IN WET STABLE TRENCH CONDITIONS.
3. PLACE TRENCH DAMS IN CLASS I EMBEDMENTS AT THE MIDPOINT OF LINE SEGMENTS LONGER THAN 100 FEET BETWEEN MANHOLES.

02317-03

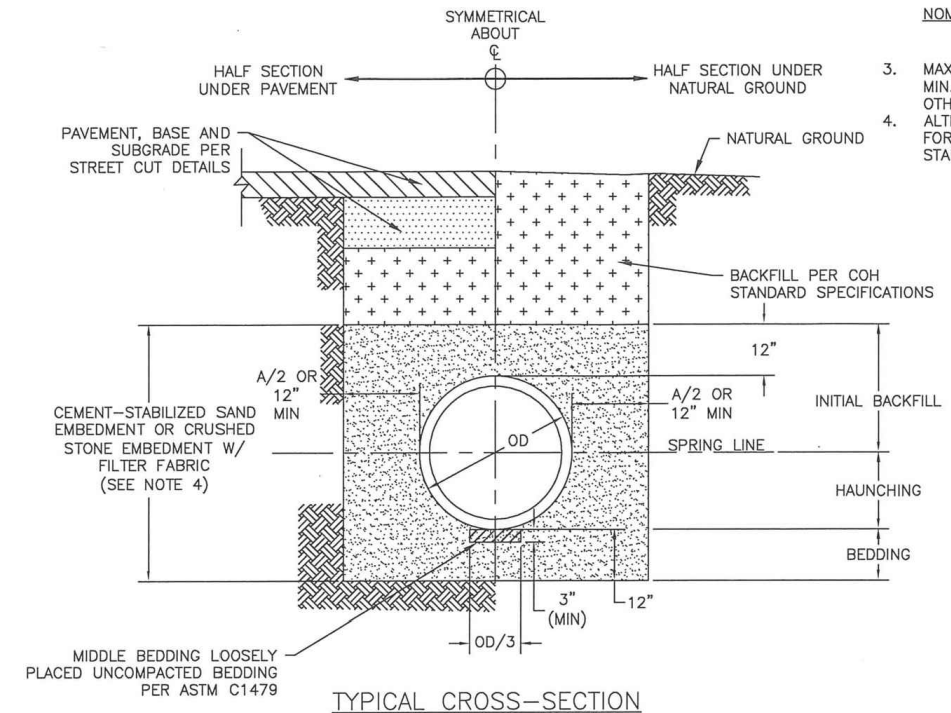

TYPICAL CROSS-SECTION

SANITARY OR STORM SEWER BEDDING AND BACKFILL FOR DRY STABLE TRENCH NTS

NOTES:

1. THIS DETAIL MAY BE USED ONLY FOR DRY STABLE TRENCH CONDITIONS PER COH STANDARD. SEE COH STANDARD SPECIFICATION FOR REQUIREMENTS IN OTHER CONDITIONS.
2. MIN. TRENCH WIDTH SHALL BE PIPE OD PLUS AN ALLOWANCE "A" FOR THE NOMINAL PIPE SIZE:

NOMINAL PIPE SIZE	"A"
18" TO 30"	24"
OVER 30"	36"

3. MAX. TRENCH WIDTH SHALL BE NOT GREATER THAN MIN. TRENCH WIDTH PLUS 24 INCHES, UNLESS OTHERWISE NOTED.
4. ALTERNATIVE EMBEDMENT BACKFILL MATERIALS FOR FORCE MAINS MAY BE ALLOWED. SEE COH STANDARD SPECIFICATIONS.

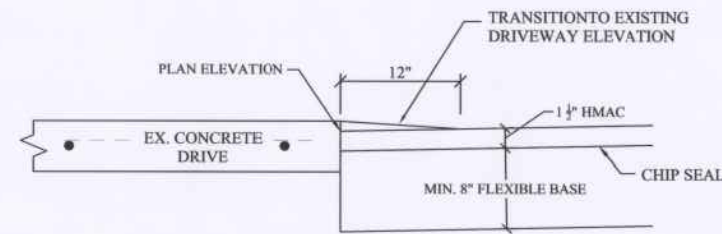

TYPICAL CONCRETE DRIVEWAY APPROACH DETAIL

NOT TO SCALE

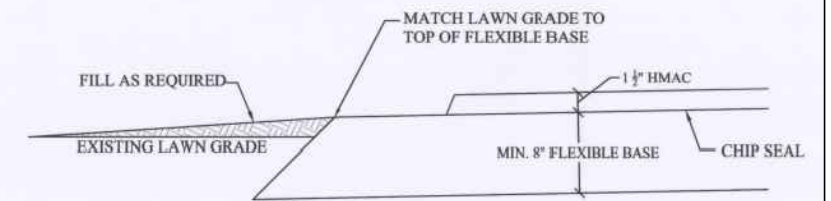

TYPICAL PAVEMENT ADJACENT TO LAWN DETAIL

NOT TO SCALE

FILE INFO: Z:\Galveston County\Blue Heron\04 CAD\14 DRIVEWAY TIE-IN AND STORM SEWER DETAILS.dwg PLOTTED BY: James Calibort DATE: Sep 11, 2020 8:55am

NO.	REVISIONS	DATE	NAME

GALVESTON COUNTY
ENGINEERING
DEPARTMENT



Zarinkel
Engineering Services, Inc.

817 Caroline St
Houston, Texas 77002
Ph: 832.242.2426
Fax: 832.242.2445
Firm Reg. # F-004270

Giti Zarinkel
8-11-2020

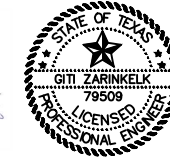

PROJECT TITLE:	BLUE HERON DRIVE	
DRAWN BY:		PROJECT ID:
CK'D BY:	SHEET DESCRIPTION: DRIVEWAY TIE-IN AND	BV01
SCALE:	STORM SEWER DETAILS	
DATE:	APPROVED BY:	SHEET NO:
9/11/2020		14 / 30

FILE INFO: Z:\Galveston County\Blue Heron\04 CAD\15 C-004-004 SWPPP.dwg PLOTTED BY: James Gaibort DATE: Sep 10, 2020 3:46pm

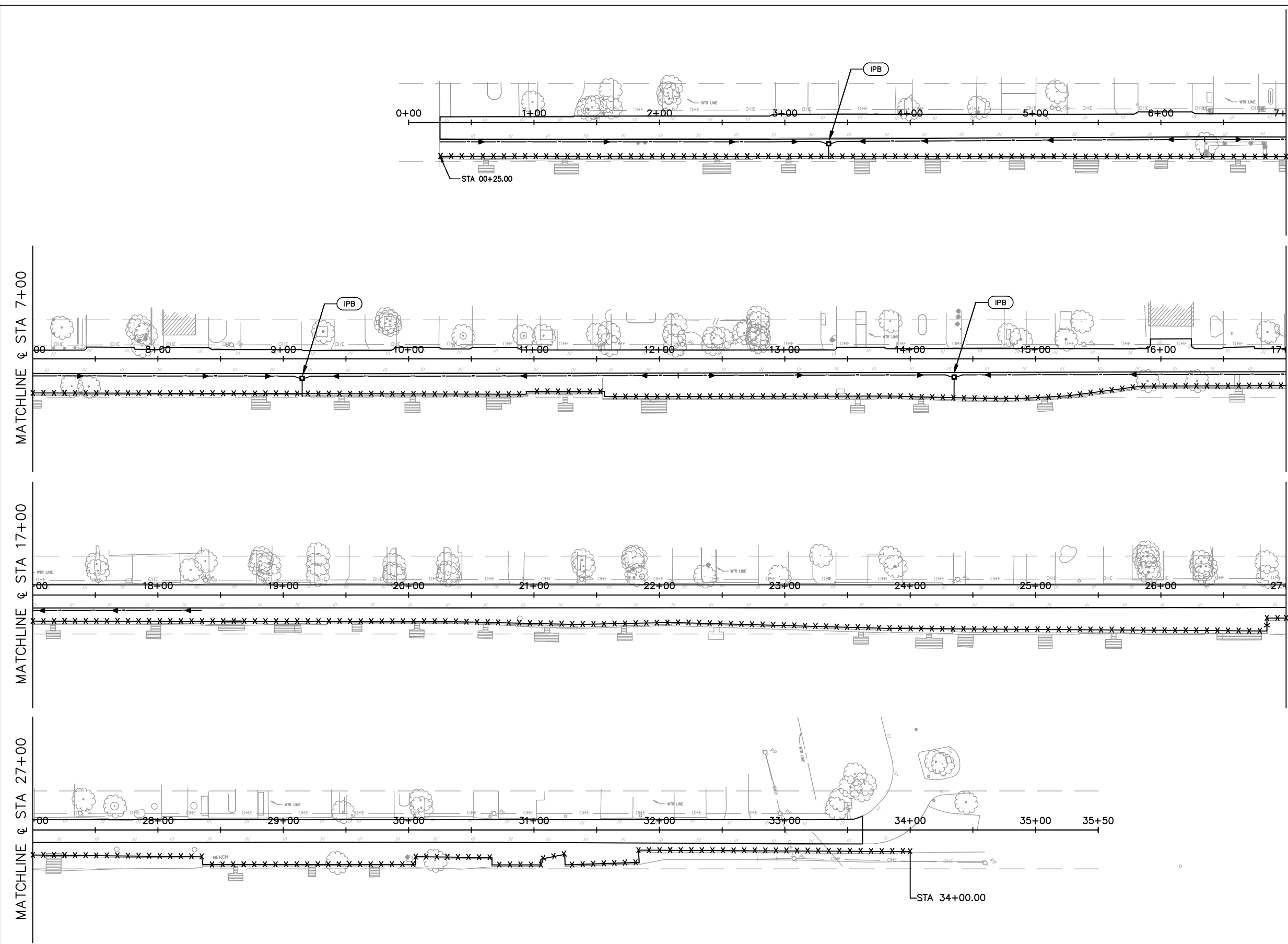

LEGEND

- x-x-x-x REINFORCED FILTER FABRIC BARRIER
- (IPB) INLET PROTECTION BARRIER

NOTES

1. DESIGNATED INLETS SHALL BE PROTECTED AT ALL TIMES DURING CONSTRUCTION. THERE IS NO SEPARATE PAY FOR REMOVING AND REINSTALLING PROTECTION AS CONSTRUCTION PROGRESSES
2. THE LOCATION OF CONSTRUCTION SUPPORT ACTIVITIES INCLUDING MATERIALS, WASTE, BORROW, FILL, AND EQUIPMENT STORAGE AREA WILL BE SHOWN ON THE PLAN SHEETS ONCE ESTABLISHED BY THE CONTRACTOR. THESE SITES WILL BE INCLUDED IN THE INSPECTION REPORT.
3. THE LOCATION OF STABILIZED CONSTRUCTION EXIT, VEHICLE WASH AREAS, INCLUDING CONCRETE WASHOUTS, WILL BE SHOWN ON THE PLANS ONCE ESTABLISHED BY THE CONTRACTOR. THIS SITE WILL BE INCLUDED IN THE INSPECTION REPORT.
4. THE FOLLOWING RECORDS WILL BE MAINTAINED BY THE CONTRACTOR AND WILL BE MADE READILY AVAILABLE UPON REQUEST OF PARTIES LISTED IN PART III.D.1 OF THE TPDES GENERAL PERMIT TXR150000:
 1. DATES WHEN MAJOR GRADING ACTIVITIES OCCUR;
 2. ALL DATES WHEN CONSTRUCTION ACTIVITIES TEMPORARILY OR PERMANENTLY CEASE ON A PORTION OF THE SITE; AND
 3. THE DATES WHEN STABILIZATION (BOTH TEMPORARY AND/OR PERMANENT) MEASURES ARE INITIATED.

SHEET 1 OF 1

NO.	REVISIONS	DATE	NAME

**GALVESTON COUNTY
ENGINEERING
DEPARTMENT**



Zarinkel
Engineering Services, Inc.
817 Caroline St.
Houston, Texas
Ph: 832.242.2426
Fax: 832.242.2445
Firm Reg. # F-004270



PROJECT TITLE: BLUE HERON DRIVE		PROJECT ID: BV01
DRAWN BY:	FROM STA 00+00 TO STA 34+00	SHEET NO: 15 / 30
CK'D BY:	SHEET DESCRIPTION: STORM WATER POLLUTION	
SCALE:	PREVENTION PLAN	
DATE: 9/10/2020	APPROVED BY:	

FILE INFO: Z:\Galveston County\Blue Heron\04 CAD\16 SWPPP DET.dwg PLOTTED BY: James Gaibort DATE: Sep 10, 2020 3:46pm

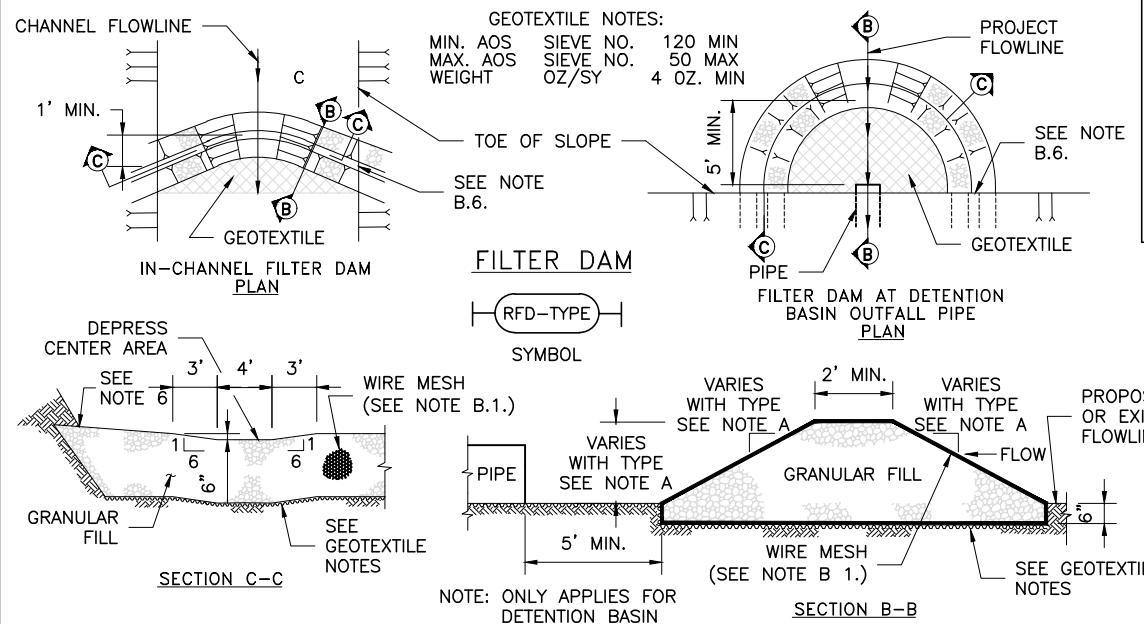
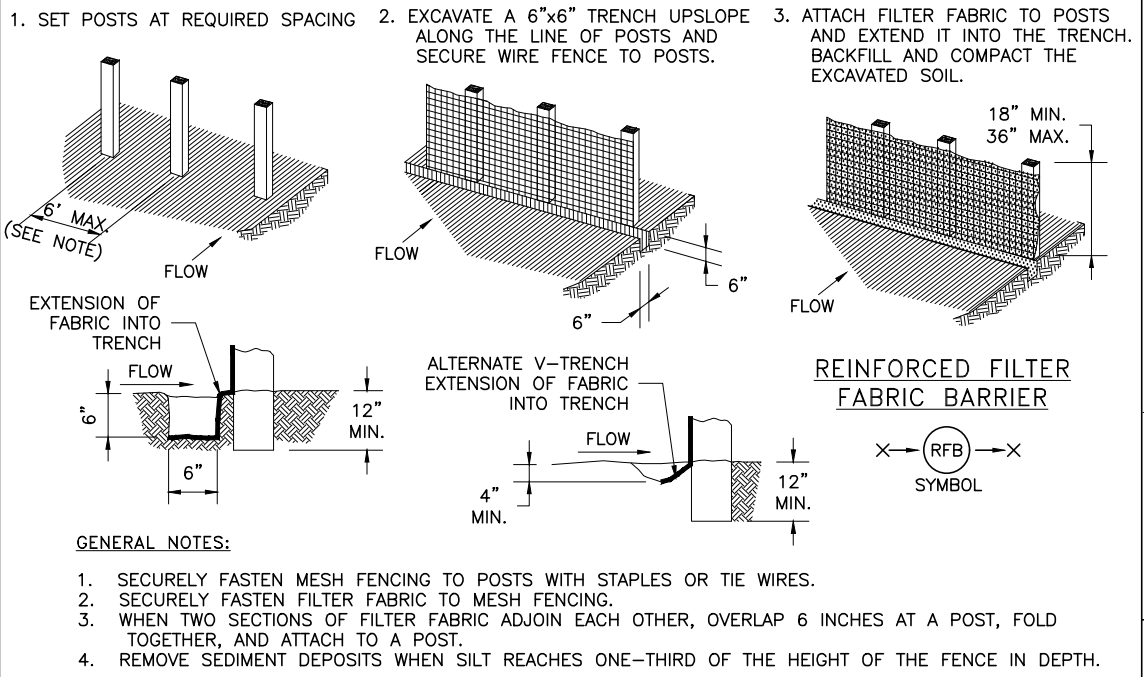

- A. TYPES OF FILTER DAMS**
- TYPE 1 (NON-REINFORCED)
 - HEIGHT - 18-24 INCHES. MEASURE VERTICALLY FROM EXISTING GROUND TO TOP OF FILTER DAM.
 - TOP WIDTH - 2 FEET (MINIMUM)
 - SLOPES - 2:1 (MAXIMUM).
 - TYPE 2 (REINFORCED)
 - HEIGHT - 18-36 INCHES. MEASURE VERTICALLY FROM EXISTING GROUND TO TOP OF FILTER DAM.
 - TOP WIDTH - 2 FEET (MINIMUM).
 - SLOPES - 2:1 (MAXIMUM).
 - TYPE 3 (REINFORCED)
 - HEIGHT - 36-48 INCHES. MEASURE VERTICALLY FROM EXISTING GROUND TO TOP OF FILTER DAM.
 - TOP WIDTH - 2 FEET (MINIMUM).
 - SLOPES - 3:1 (MAXIMUM).
 - TYPE 4 (GABION)
 - HEIGHT - 30 INCHES (MINIMUM). MEASURE VERTICALLY FROM EXISTING GROUND TO TOP OF FILTER DAM.
 - TOP WIDTH - 2 FEET (MINIMUM).
 - TYPE 5. AS SHOWN ON THE PLANS.
- B. CONSTRUCT FILTER DAMS ACCORDING TO THE FOLLOWING CRITERIA UNLESS SHOWN OTHERWISE ON THE PLANS.**
- TYPE 2 AND 3 FILTER DAMS: SECURE WITH 20 GAUGE GALVANIZED WOVEN WIRE MESH WITH 1 INCH DIAMETER HEXAGONAL OPENINGS.
 - PLACE GRANULAR FILL ON THE WIRE MESH TO HEIGHT AND SLOPES SHOWN ON PLANS OR AS SPECIFIED BY THE ENGINEER.
 - 3-5 INCHES FOR ROCK FILTER DAM TYPES 1, 2 AND 4.
 - 4-8 INCHES FOR ROCK FILTER DAM TYPE REFER TO GRANULAR FILL IN SPECIFICATION SECTION No. 02378 RIPRAP AND GRANULAR FILL.
 - FOLD WIRE MESH AT UPSTREAM SIDE OVER GRANULAR FILL AND TIGHTLY SECURED TO ITSELF ON THE DOWNSTREAM SIDE USING WIRE TIES OR HOG RINGS.
 - IN STREAMS: SECURE OR STAKE MESH TO STREAM BED PRIOR TO AGGREGATE PLACEMENT.
 - SEE HCFCD SPECIFICATION SECTION NO. 02364-FILTER DAMS.
 - EMBED ONE FOOT MINIMUM INTO SLOPE AND RAISE ONE FOOT HIGHER THAN CENTER OF DEPRESSED AREA AT SLOPE.

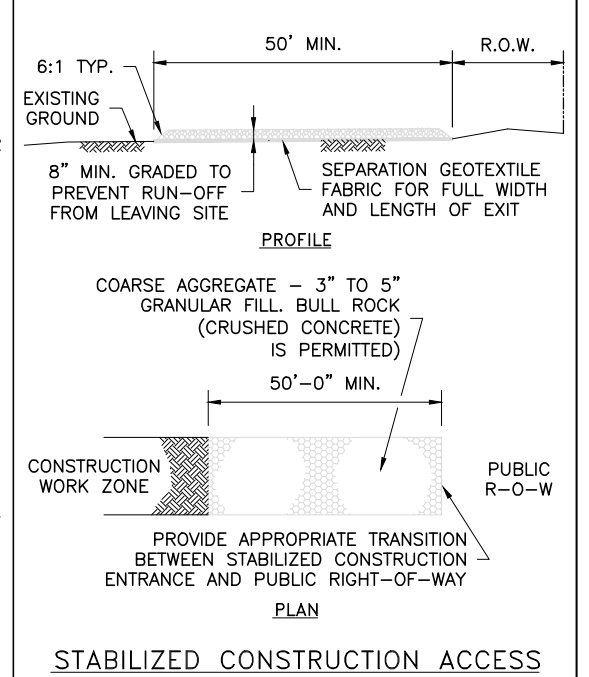
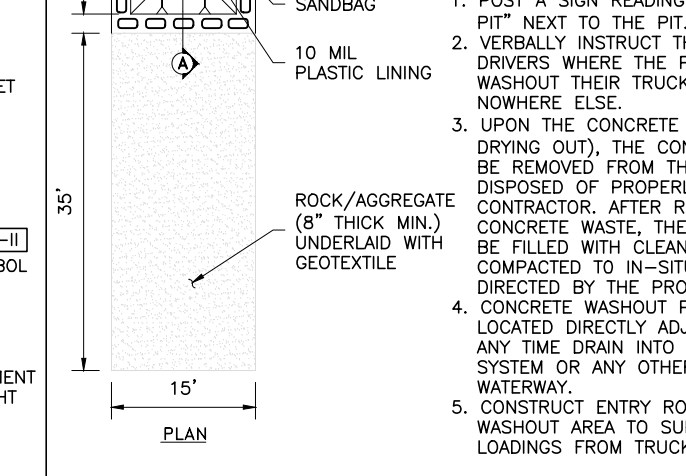
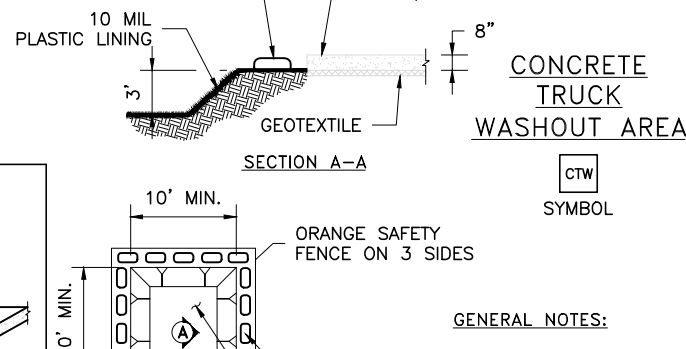
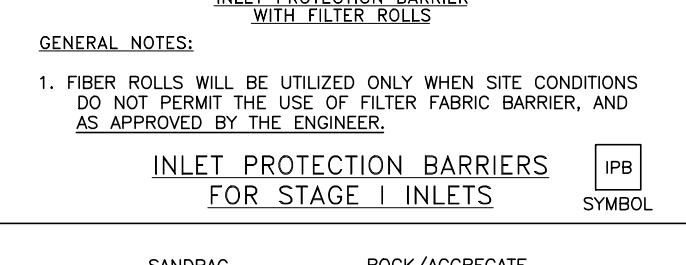
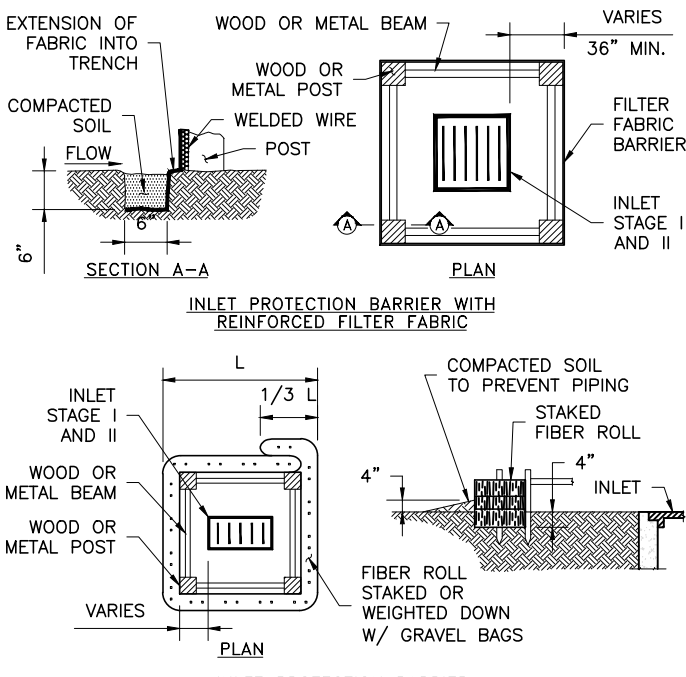
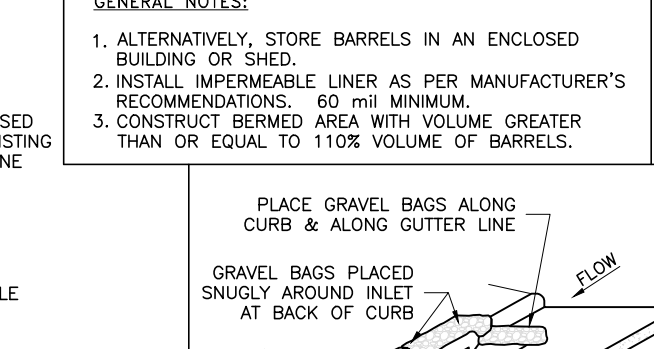
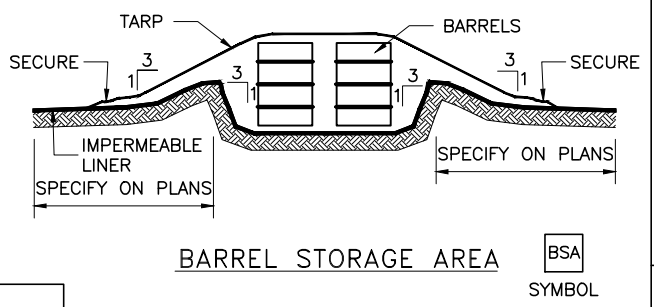
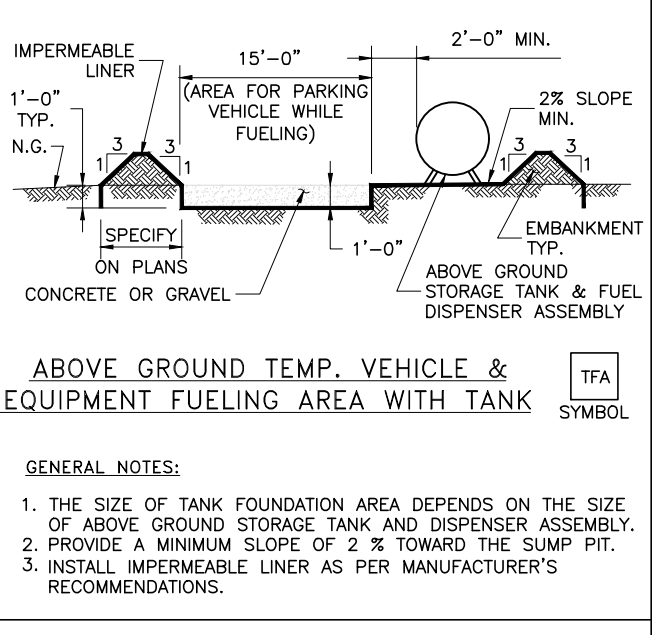

NO.	REVISIONS	DATE	NAME

GALVESTON COUNTY ENGINEERING DEPARTMENT

THE STATE OF TEXAS
 COUNTY OF GALVESTON

Zarinkelk
 Engineering Services, Inc.
 817 Caroline St
 Houston, Texas 77002
 Ph: 832.242.2426
 Fax: 832.242.2445
 Firm Reg. # F-004270

STATE OF TEXAS
 CIVIL ENGINEER
 GUY ZARINKELK
 79508
 LICENSED PROFESSIONAL ENGINEER
 8-11-2020

PROJECT TITLE: BLUE HERON DRIVE	PROJECT ID: BV01
DRAWN BY:	SHEET DESCRIPTION: STORM WATER POLLUTION PREVENTION
CK'D BY:	SCALE: PLAN DETAIL
DATE: 9/10/2020	APPROVED BY:
	SHEET NO: 16 / 30

FILE INFO: Z:\Galveston County\Blue Heron\04 CAD\17 C005-001 ADVANCED WARNING SIGN.dwg PLOTTED BY: James Calibort DATE: Sep 10, 2020 3:47pm

BEGINNING OF PROJECT
STA. 00+25

BLUE HERON DRIVE

END OF PROJECT
STA. 33+62.05

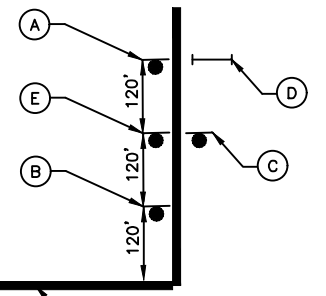

SIGNS

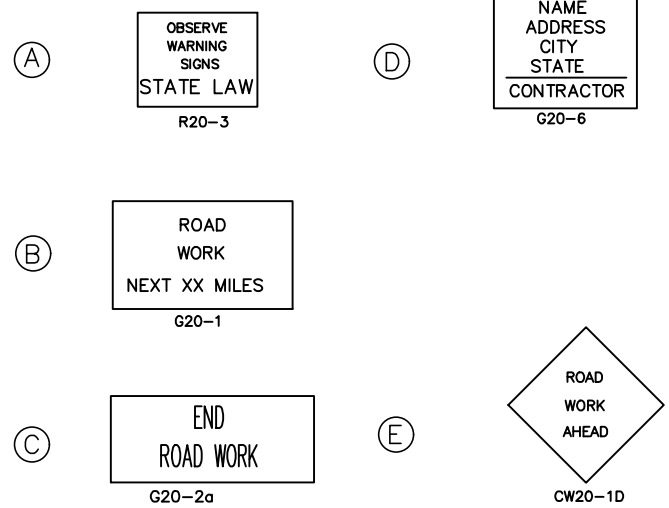

NOTES

1. ALL ADVANCED WARNING SIGNS TO BE SET PRIOR TO START OF CONSTRUCTION ACTIVITIES AND TO REMAIN IN PLACE UNTIL ALL CONSTRUCTION ACTIVITIES ARE COMPLETE AND ACCEPTED BY GALVESTON COUNTY.
2. MAX. PAVEMENT DROP-OFF SHALL NOT EXCEED 2'.
3. ALL FLAGGERS SHALL BE IN RADIO CONTACT WITH EACH OTHER AT ALL TIMES.
4. ADVANCE SIGNING SHALL BE PLACED A MINIMUM OF TWO WEEKS IN ADVANCE TO INFORM OF POSSIBLE DELAY. CONTRACTOR SHALL NOTIFY THE GALVESTON COUNTY ENGINEERING DEPARTMENT AT LEAST TWO WEEKS PRIOR TO ANY CONSTRUCTION.
5. ALL PORTABLE SIGNING, DRUMS AND CONES SHALL BE REMOVED AT THE END OF EACH DAY.
6. ACCESS TO EXISTING BUSINESSES OR RESIDENCES SHALL BE MAINTAINED AT ALL TIMES.

LEGEND

- CONSTRUCTION AREA
- OPEN TO TRAFFIC
- HEAVY WORK VEHICLE
- FLASHING ARROW BOARD (OPTIONAL)
- SIGN POST
- TUBULAR MARKERS ,CONES OR DRUMS
- FLAGGER
- SIGN SPACING
- TAPER LENGTH
- DISTANCE TO BE DETERMINED BY ENGINEER
- PROJECT SIGN

TYPICAL TRANSITION LENGTHS
AND
SUGGESTED MAXIMUM SPACING OF DEVICES

Posted Speed *	Formula	Minimum Desirable Taper Lengths **			Suggested Maximum Spacing of Device	
		10' Offset	11' Offset	12' Offset	On a Taper	On a Tangent
30	$L = \frac{WS^2}{60}$	150'	165'	180'	30'	60'-75'
35		205'	225'	245'	35'	70'-90'
40		265'	295'	320'	40'	80'-100'
45	L=WS	450'	495'	540'	45'	90'-110'
50		500'	550'	600'	50'	100'-125'
55		550'	605'	660'	55'	110'-140'
60		600'	660'	720'	60'	120'-150'
65		650'	715'	780'	65'	130'-175'

* 85th Percentile Speed may be used on roads where traffic speeds normally exceed the posted speed limit.
** Taper lengths have been rounded off.

CONSTRUCTION WARNING
SIGN SPACING

Posted Speed or 85% Speed (MPH)	X Min. Distance (feet)
30 or less	120
35	160
40	240
45	320
50	400
55	500
65	750

X=SIGN SPACING
L=TAPER
2XL=TANGENT

EXISTING POSTED SPEED LIMIT = 20
CONSTRUCTION ZONE DESIGN SPEED LIMIT = 20

NO.	REVISIONS	DATE	NAME

GALVESTON COUNTY
ENGINEERING
DEPARTMENT



Zarinkel
Engineering Services, Inc.

817 Caroline St.
Houston, Texas
Ph: 832.242.2426
Fax: 832.242.2445
Firm Reg. # F-004270

Gal Zarinkel
8-11-2020

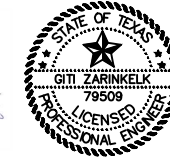

PROJECT TITLE: BLUE HERON DRIVE		PROJECT ID: BV01
DRAWN BY:	SHEET DESCRIPTION: TRAFFIC CONTROL GUIDELINES	SHEET NO: 17 / 30
CK'D BY:	PROJECT APPROACH SIGNING	
DATE: 9/10/2020	APPROVED BY:	

FILE INFO: Z:\Galveston County\Blue Heron\04 CAD\18 C-005-001 TCP.dwg PLOTTED BY: James Scibort DATE: Sep 10, 2020 3:47pm

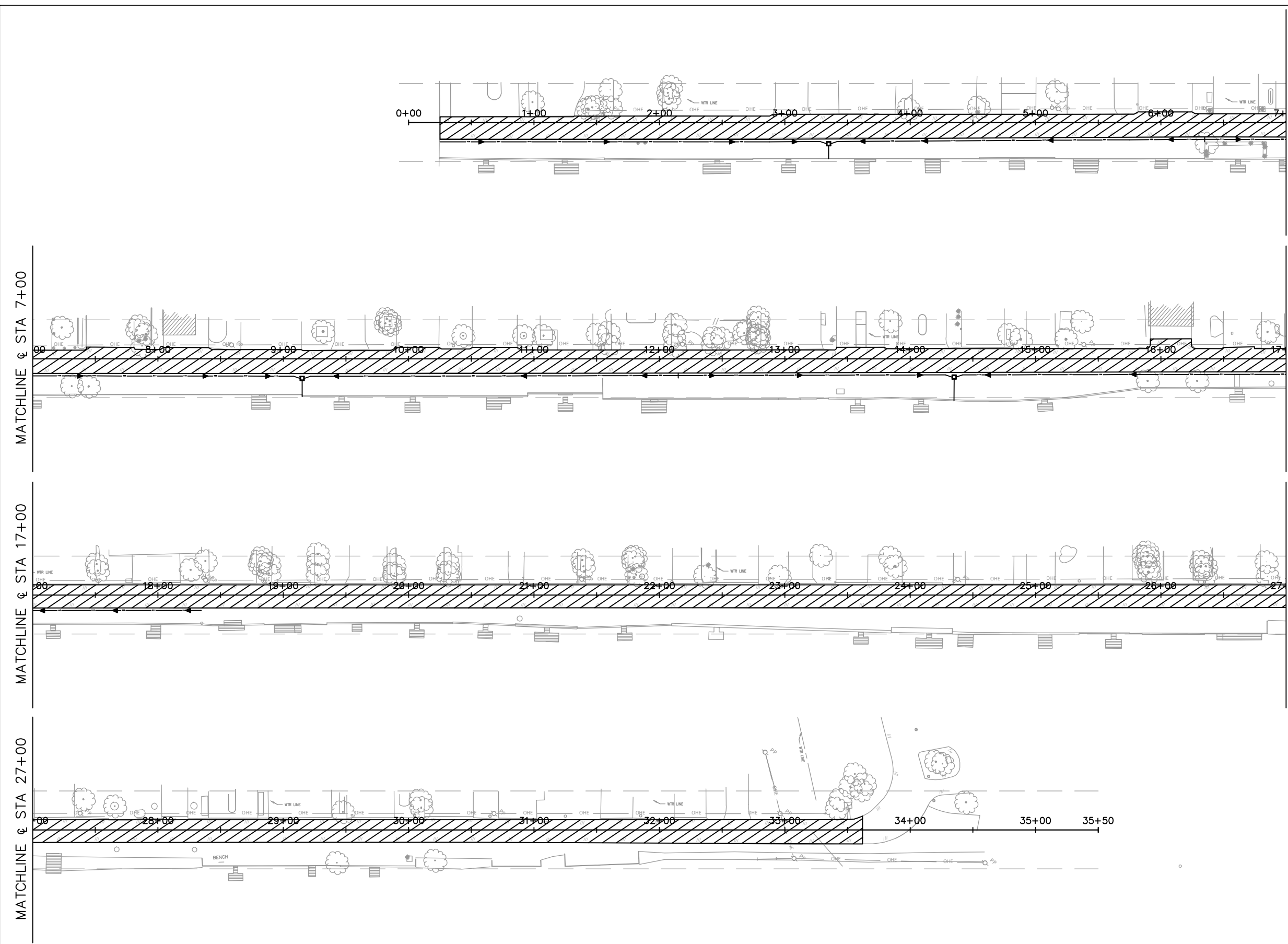

1. SET UP ADVANCED WARNING SIGNS.
2. INSTALL SWPPP AS PER PLANS
3. LOCAL TRAFFIC INGRESS AND EGRESS FOR DRIVEWAYS AND PEDESTRIAN ACCESS FACILITIES SHALL BE MAINTAINED THROUGHOUT THE CONSTRUCTION
4. CONTRACTOR SHALL CONSTRUCT ENTIRE WIDTH OF THE PROPOSED PAVEMENT IN ONE SPREAD.
5. THE LENGTH OF THE CONSTRUCTION AREA SHALL BE DETERMINED PRIOR TO CONSTRUCTION AS DIRECTED BY THE FIELD ENGINEER.
6. INSTALL SIGN B AT BEGIN OF THE CONSTRUCTION AREA, AND MOVE WITH EACH CONSTRUCTION STAGES.
7. REMOVE AND DISPOSE EXISTING ASPHALT PAVEMENT.
8. CONSTRUCT PROPOSED 3-INCH HMAC SURFACE COURSE OVER 9-INCH COLD-IN-PLACE BASE COURSE SUBGRADE.
9. PROVIDE ACCESS TO RESIDENT DURING CONSTRUCTION.
10. CONSTRUCT PROPOSED DRAINAGE FACILITIES.
11. INSTALL SODDING OVER UNPAVED DISTURBED AREA DURING CONSTRUCTION.
12. RESTORE UNPAVED AREA TO PRIOR TO CONSTRUCTION CONDITION
13. ROAD SHALL KEEP OPEN AND MAINTAIN ROADWAY SURFACE TO BE ABLE TO DRIVE ON DURING NON CONSTRUCTION PERIOD AND OVERNIGHT.

LEGEND



NOTE:
CONTRACTOR WILL NEED TO PROVIDE ALL RESIDENTS AN UPDATE ON THE TRAFFIC PATTERNS SUCH THAT RESIDENTS WILL BE ABLE TO ACCESS THEIR PROPERTY DURING CONSTRUCTION.

NO.	REVISIONS	DATE	NAME

**GALVESTON COUNTY
ENGINEERING
DEPARTMENT**



Zarinkel
Engineering Services, Inc.
817 Caroline St
Houston, Texas 77002
Ph: 832.242.2426
Fax: 832.242.2445
Firm Reg. # F-004270



PROJECT TITLE: BLUE HERON DRIVE		PROJECT ID: BV01
DRAWN BY: FROM BEGIN PROJECT	SHEET DESCRIPTION: TO END PROJECT	
CK'D BY:	SCALE: TRAFFIC CONTROL PLAN	
DATE: 9/10/2020	APPROVED BY:	
		SHEET NO: 18 / 30

FILE INFO: Z:\Galveston County\Blue Heron\04 CAD\19 SUMMARY OF EARTHWORK QTY.dwg PLOTTED BY: James Gaibort DATE: Sep 10, 2020 3:47pm

Station	Cross Sectional Areas		Average Cross Sectional Areas		Distance Between Stations Distance Between Stations [FT]	Volumes		
	Total Roadway Excavation [SF]	Embankment Area [SF]	Average Total Roadway Excavation [SF]	Average Embankment Area [SF]		ITEM 110 ROADWAY EXCAVATION [CY] <i>PAY</i>	REUSEABLE ROADWAY EXCAVATION *[CY]	ROADWAY EMBANKMENT [CY]
	AR	BR	FR	GR	KR	LR	PR	QR
000+25	0.31	0						
			0.745	0	75	2	2	0
001+00	1.18	0						
			1.09	0	100	4	4	0
002+00	1	0						
			1.075	0	100	4	4	0
003+00	1.15	0						
			0.795	0	100	3	3	0
004+00	0.44	0						
			0.47	0	100	2	2	0
005+00	0.5	0						
			0.27	0	100	1	1	0
006+00	0.04	0						
			0.345	0	100	1	1	0
007+00	0.65	0						
			0.4	0	100	1	1	0
008+00	0.15	0						
			0.21	0.015	100	1	1	0
009+00	0.27	0.03						
			0.295	0.03	100	1	1	0
010+00	0.32	0.03						
			0.36	0.015	100	1	1	0
011+00	0.4	0						
			0.215	0	100	1	1	0
012+00	0.03	0						
			0.17	0.005	100	1	1	0
013+00	0.31	0.01						
			0.56	0.005	100	2	2	0
014+00	0.81	0						
			1.085	0	100	4	4	0
015+00	1.36	0						
			1.425	0	100	5	5	0
016+00	1.49	0						
			1.26	0	100	5	5	0

Station	Cross Sectional Areas		Average Cross Sectional Areas		Distance Between Stations Distance Between Stations [FT]	Volumes		
	Total Roadway Excavation [SF]	Embankment Area [SF]	Average Total Roadway Excavation [SF]	Average Embankment Area [SF]		ITEM 110 ROADWAY EXCAVATION [CY] <i>PAY</i>	REUSEABLE ROADWAY EXCAVATION *[CY]	ROADWAY EMBANKMENT [CY]
	AR	BR	FR	GR	KR	LR	PR	QR
017+00	1.03	0						
			0.83	0	100	3	3	0
018+00	0.63	0						
			0.315	0.0525	100	1	1	0
019+00	0	0.105						
			0	0.08	100	0	0	0
020+00	0	0.055						
			0	0.10625	100	0	0	0
021+00	0	0.1575						
			0	0.19875	100	0	0	1
022+00	0	0.24						
			0	0.14375	100	0	0	1
023+00	0	0.0475						
			0	0.02375	100	0	0	0
024+00	0	0						
			0	0.02125	100	0	0	0
025+00	0	0.0425						
			0	0.11025	100	0	0	0
026+00	0	0.178						
			0	0.239	100	0	0	1
027+00	0	0.3						
			0	0.43	100	0	0	2
028+00	0	0.56						
			0	0.6025	100	0	0	2
029+00	0	0.645						
			0	0.884	100	0	0	3
030+00	0	1.123						
			0	0.6965	100	0	0	3
031+00	0	0.27						
			0	0.18875	100	0	0	1
032+00	0	0.1075						
			0	0.07125	100	0	0	0
033+00	0	0.035						
					Roadway Totals:	43	43	15

NO.	REVISIONS	DATE	NAME

GALVESTON COUNTY
ENGINEERING
DEPARTMENT

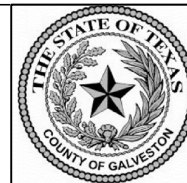



Zarinkel
Engineering Services, Inc.
817 Caroline St
Houston, Texas 77002
Ph: 832.242.2426
Fax: 832.242.2445
Firm Reg. # F-004270

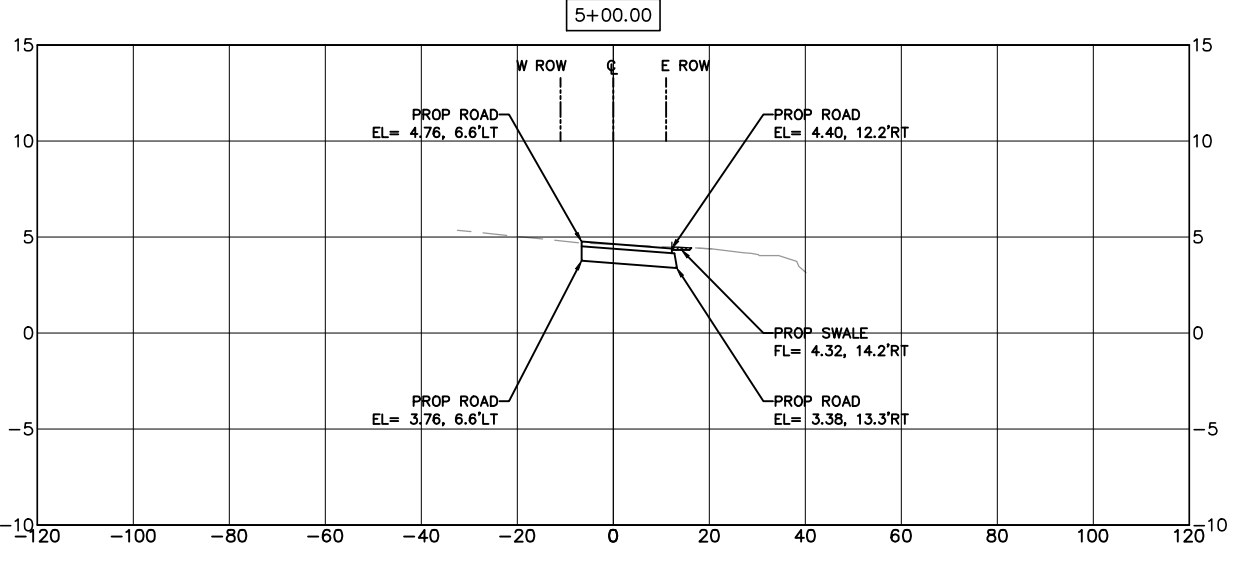
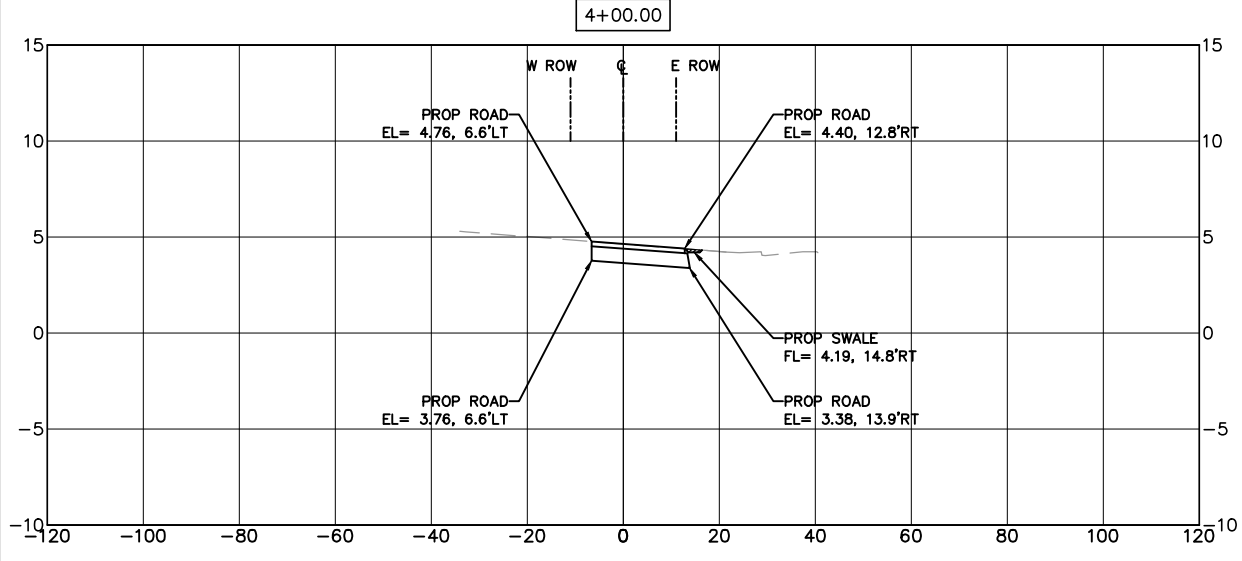
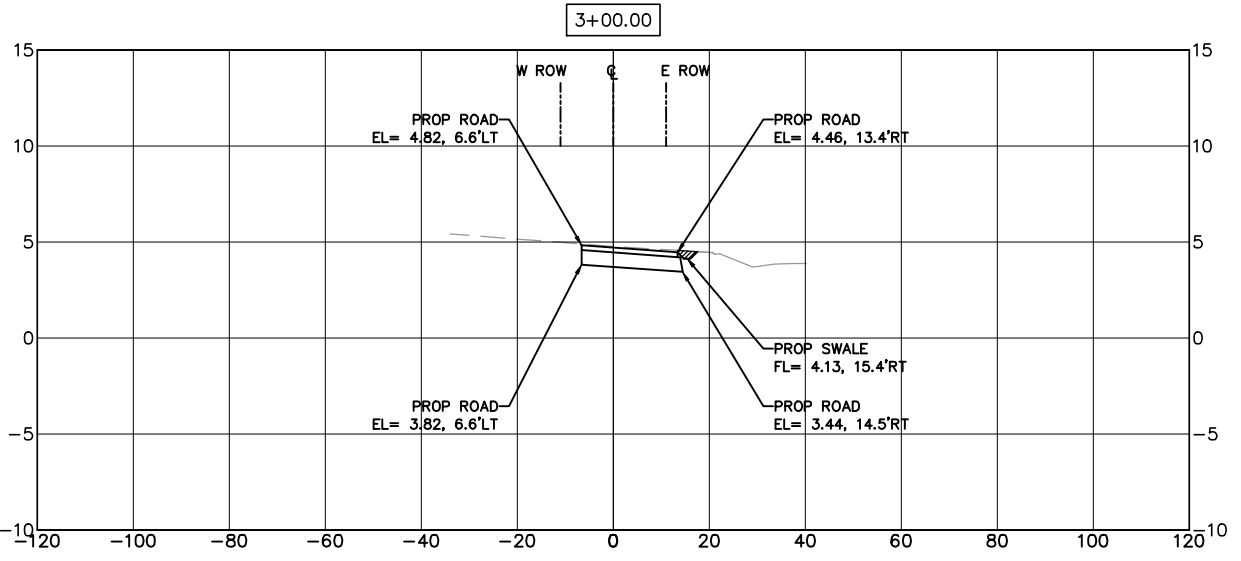
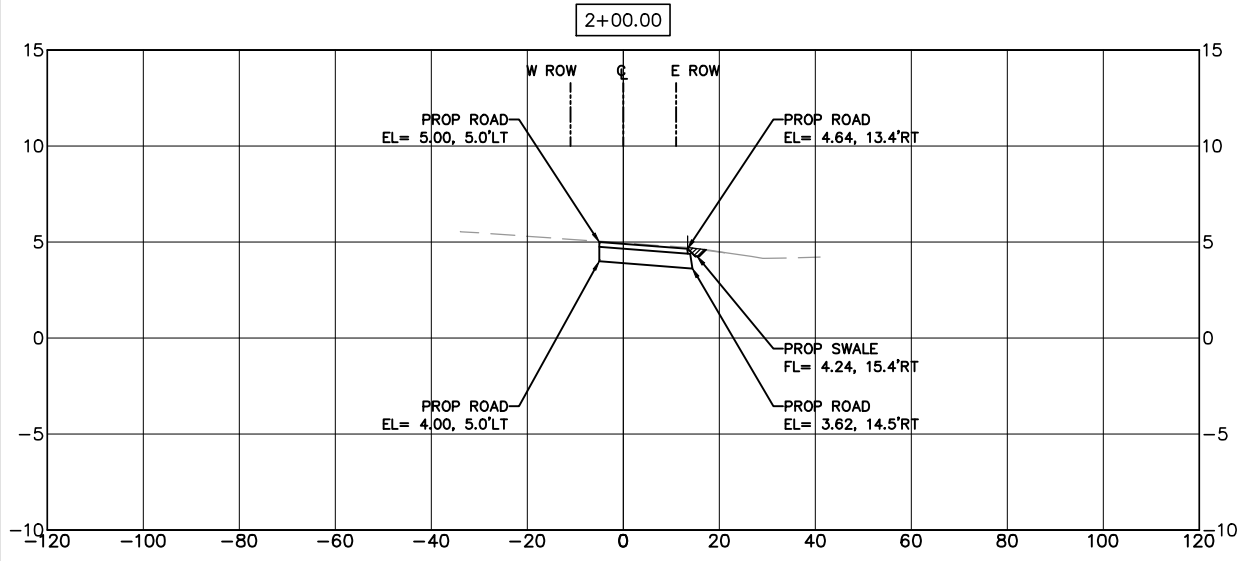
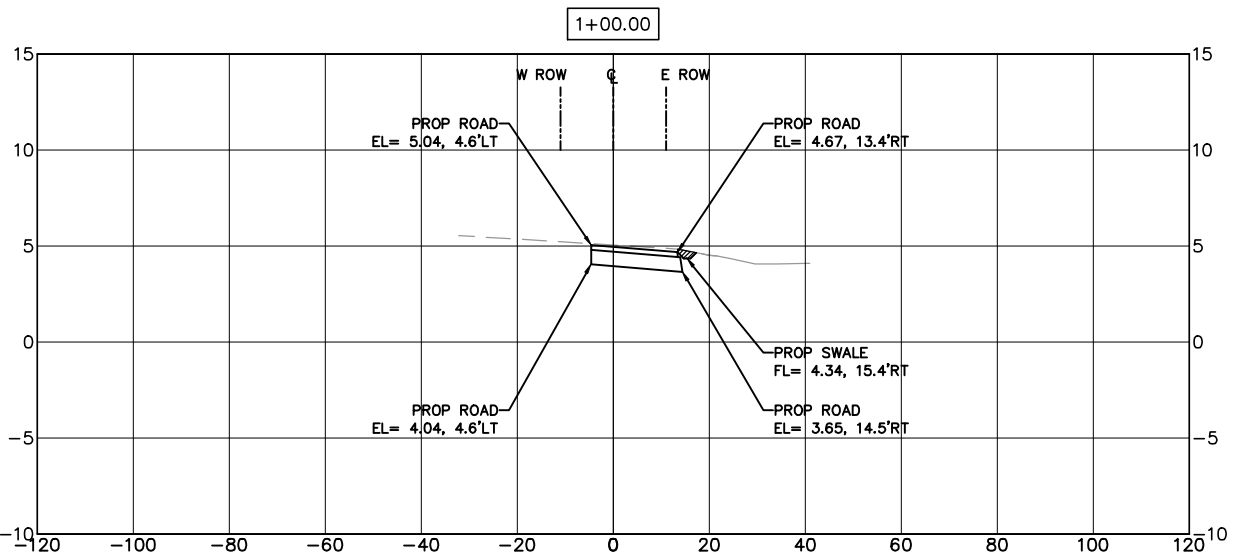
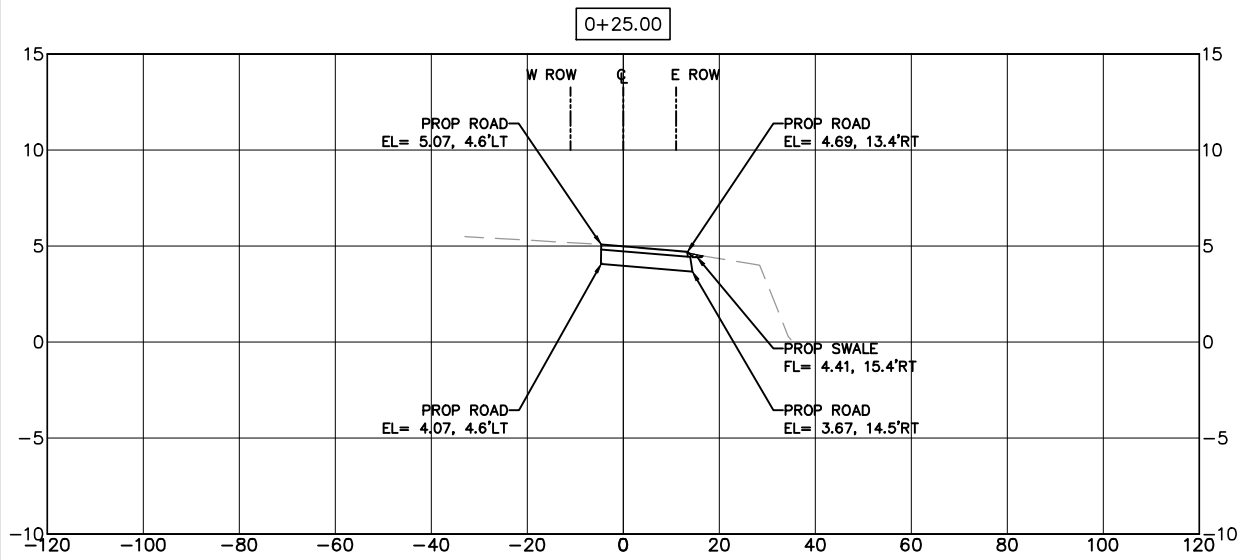

PROJECT TITLE: BLUE HERON DRIVE		PROJECT ID: BV01
DRAWN BY:	SHEET DESCRIPTION: SUMMARY OF EARTHWORK QUANTITIES	SHEET NO: 19 / 30
CK'D BY:	APPROVED BY:	
SCALE:	DATE: 9/10/2020	

FILE INFO: Z:\Galveston County\Blue Heron\04 CAD\20 - 25 C-005-001 CROSS SECTIONS.dwg PLOTTED BY: James Gaibort DATE: Sep 10, 2020 3:48pm



LEGEND:
 CUT 
 FILL 

NO.	REVISIONS	DATE	NAME

**GALVESTON COUNTY
 ENGINEERING
 DEPARTMENT**





Zarinkel
 Engineering Services, Inc.
 817 Caroline St
 Houston, Texas
 Ph: 832.242.2426
 Fax: 832.242.2445
 Firm Reg. # F-004270



PROJECT TITLE: BLUE HERON DRIVE		PROJECT ID: BV01
DRAWN BY:	SHEET DESCRIPTION: CROSS SECTIONS	
CK'D BY:		
SCALE:		
DATE: 9/10/2020	APPROVED BY:	SHEET NO: 20 / 30

FILE INFO: Z:\Galveston County\Blue Heron\04 CAD\20 - 25 C-005-001 CROSS SECTIONS.dwg PLOTTED BY: James Gaibort DATE: Sep 10, 2020 3:47pm

LEGEND:
 CUT 
 FILL 

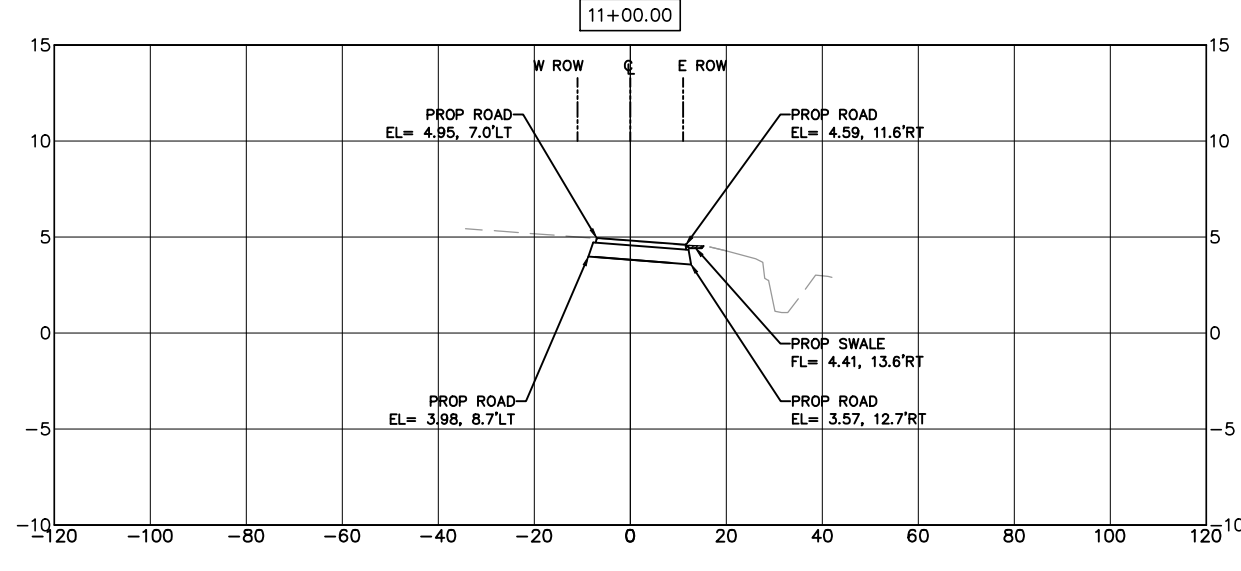
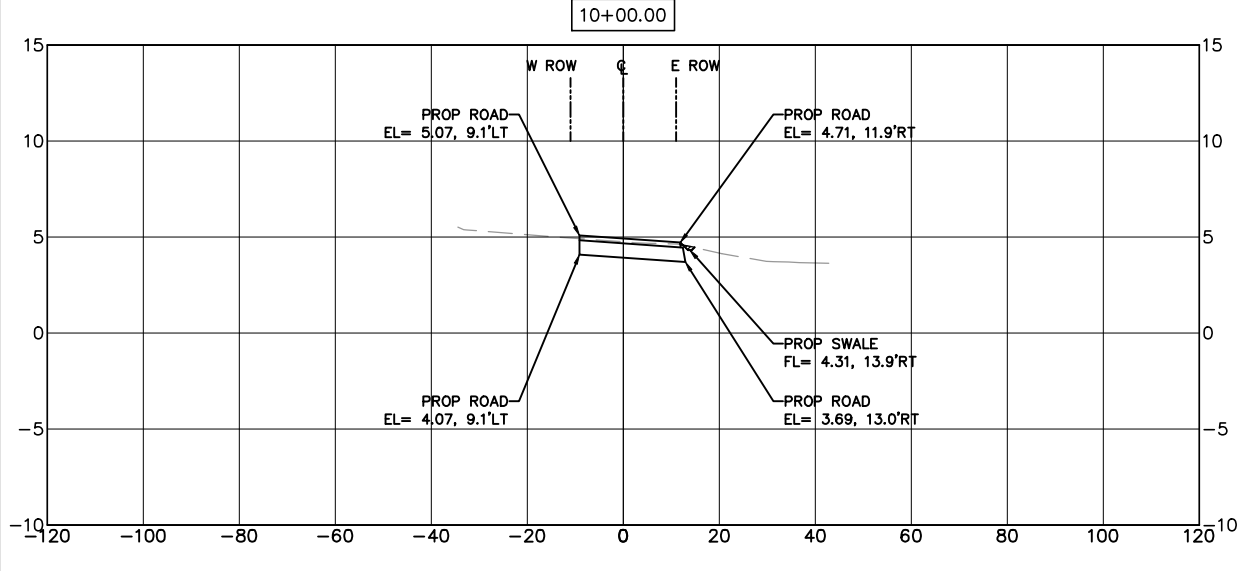
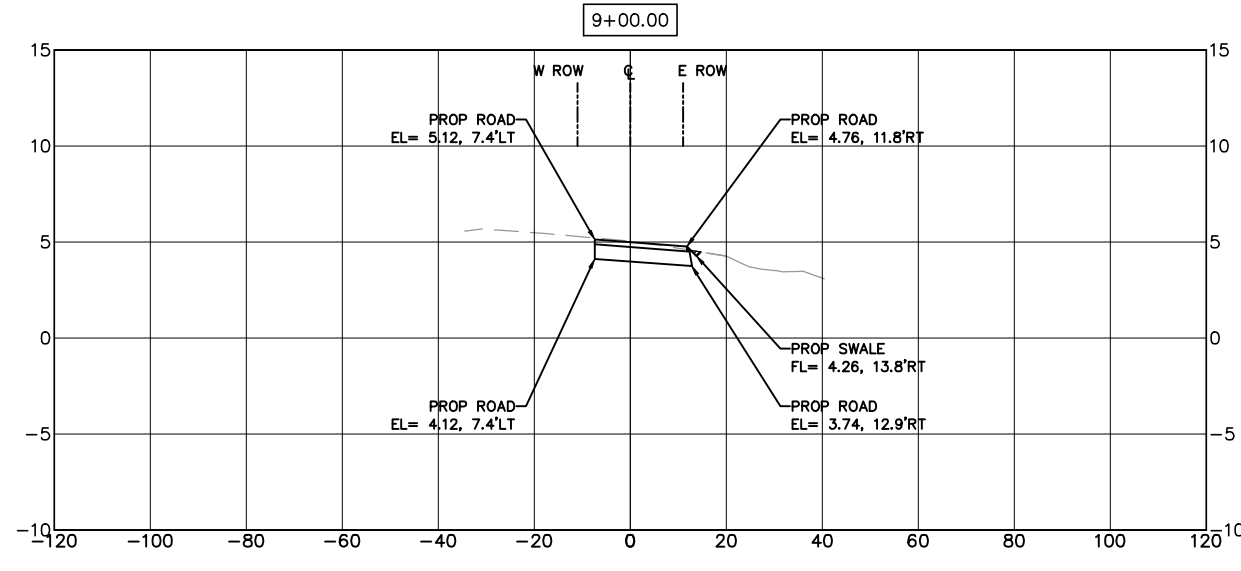
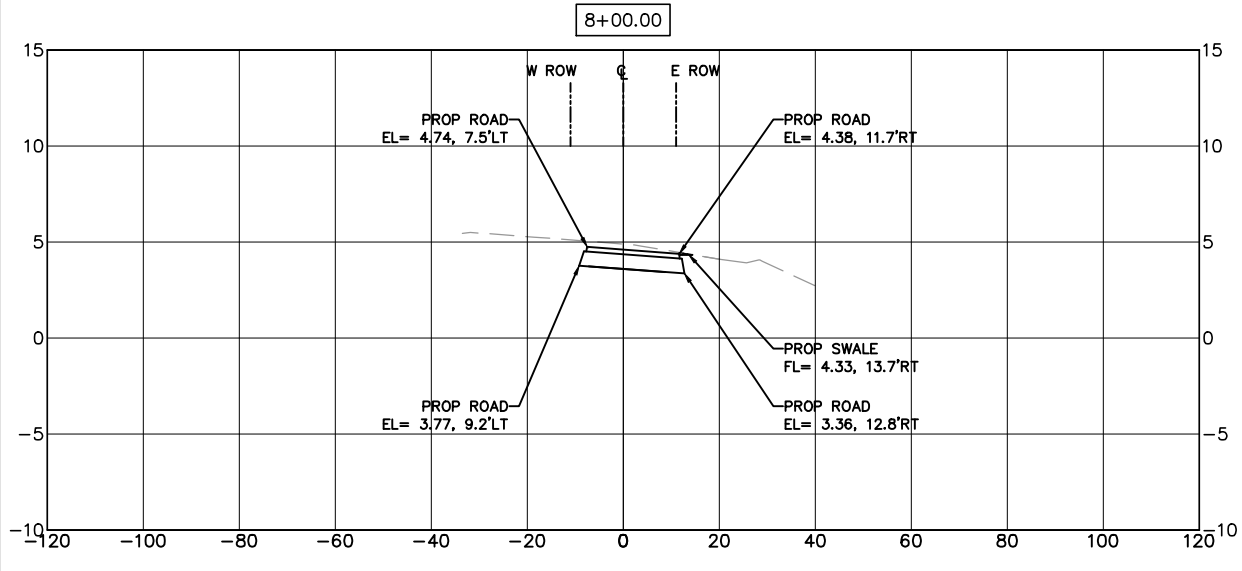
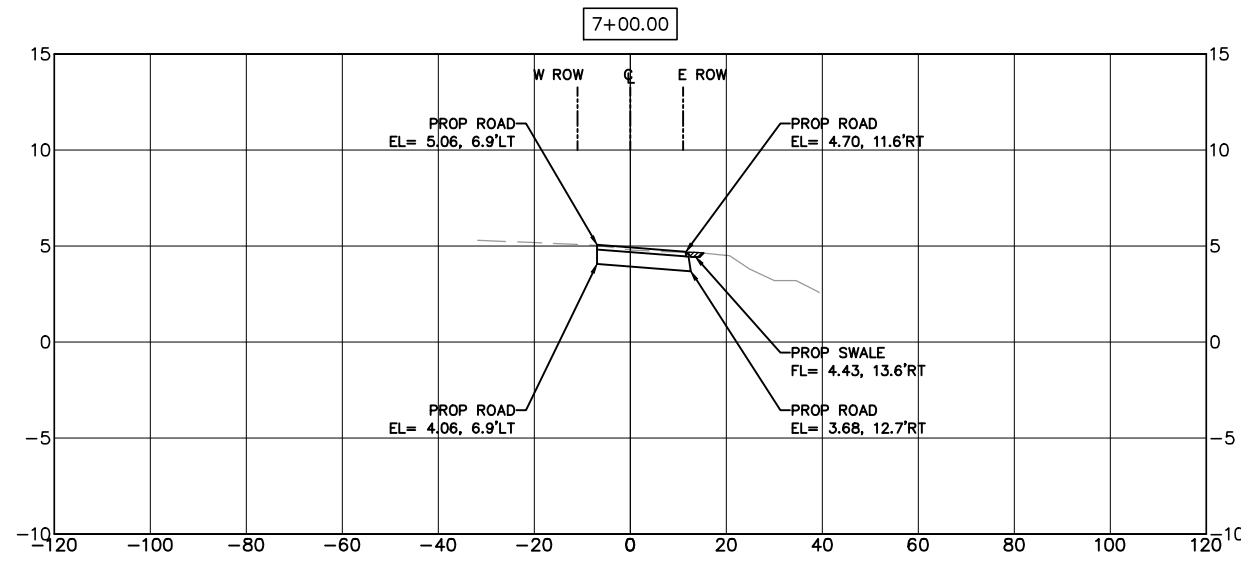
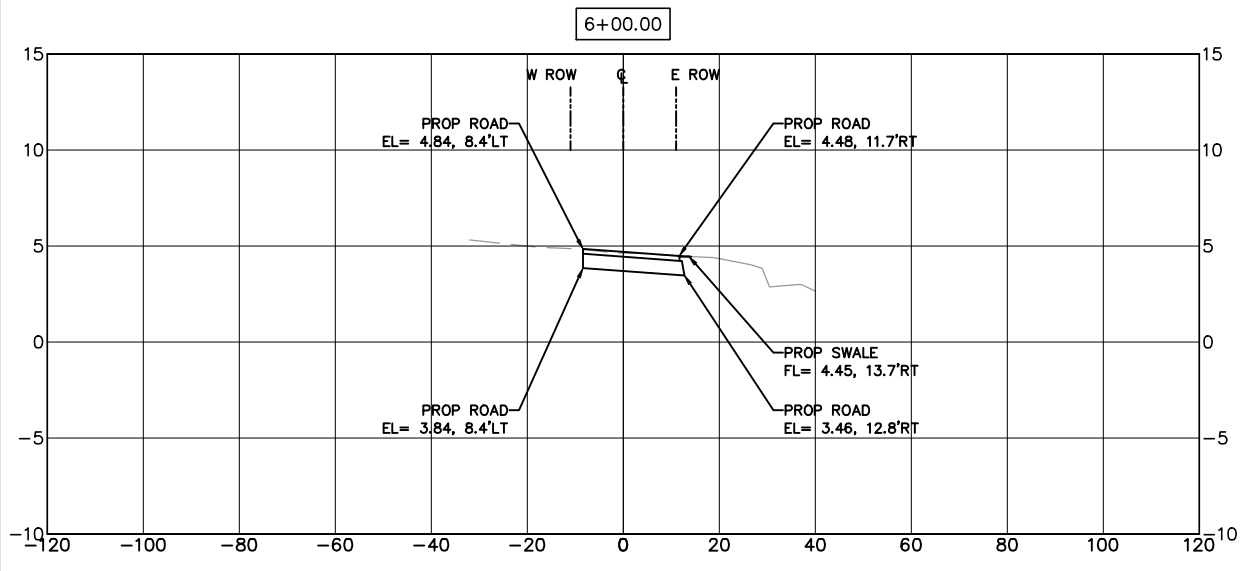

SHEET 2 OF 6

NO.	REVISIONS	DATE	NAME

**GALVESTON COUNTY
 ENGINEERING
 DEPARTMENT**





Zarinkel
 Engineering Services, Inc.
 817 Caroline St.
 Houston, Texas
 Ph: 832.242.2426
 Fax: 832.242.2445
 Firm Reg. # F-004270



PROJECT TITLE: BLUE HERON DRIVE		PROJECT ID: BV01
DRAWN BY:	SHEET DESCRIPTION: CROSS SECTIONS	SHEET NO: 21 / 30
CK'D BY:	DATE: 9/10/2020	APPROVED BY:

FILE INFO: Z:\Galveston County\Blue Heron\04 CAD\20 - 25 C-005-001 CROSS SECTIONS.dwg PLOTTED BY: James Gaibort DATE: Sep 10, 2020 3:47pm

LEGEND:
 CUT 
 FILL 

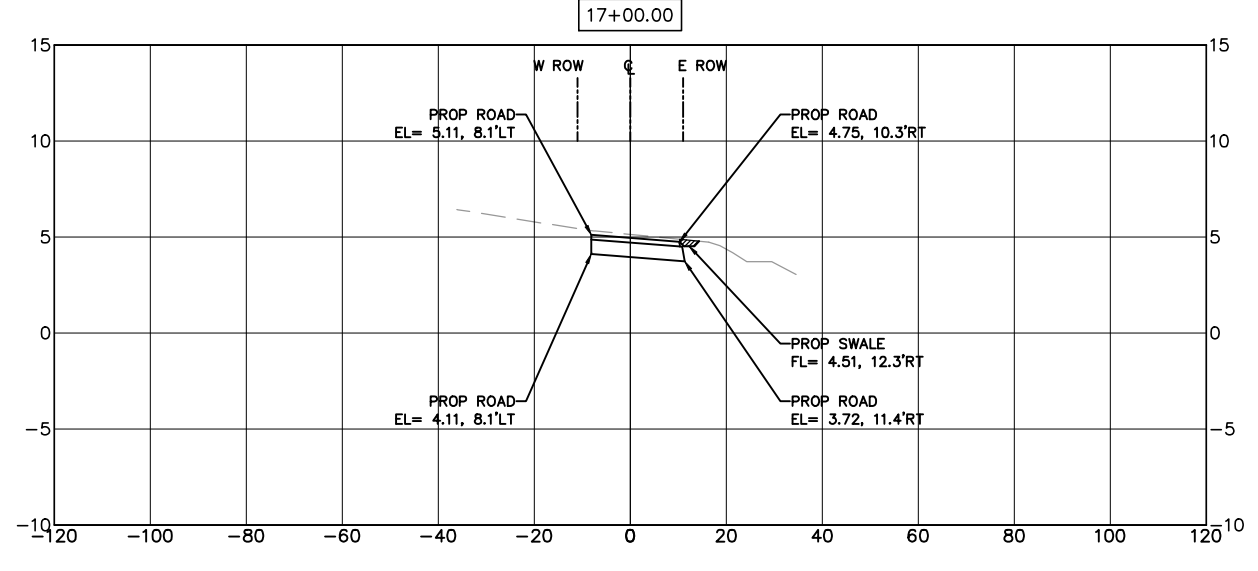
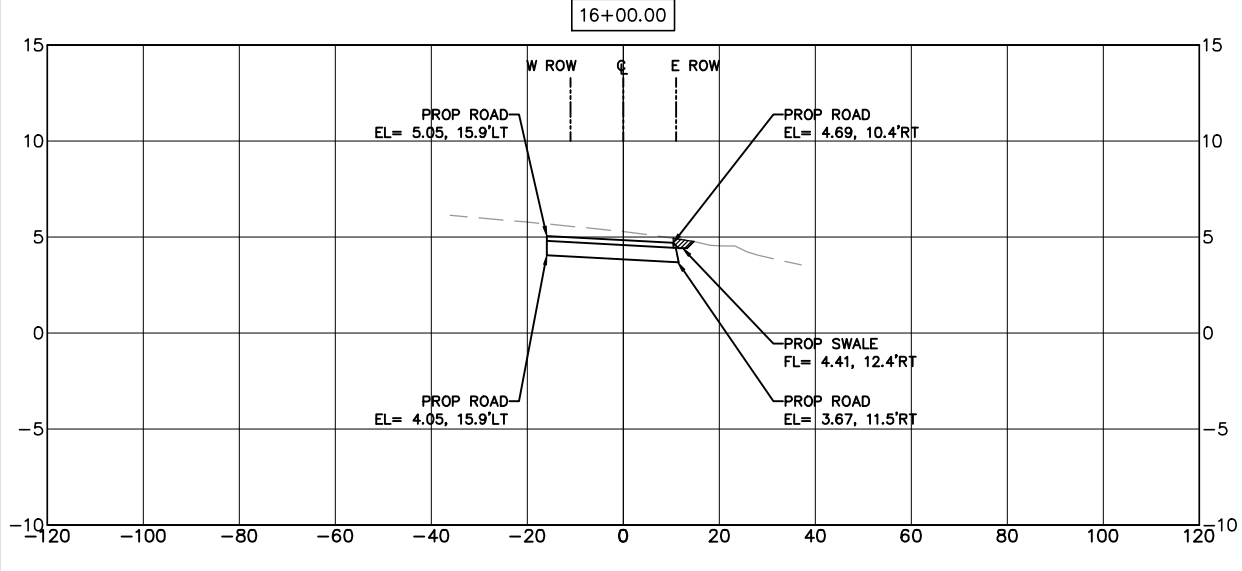
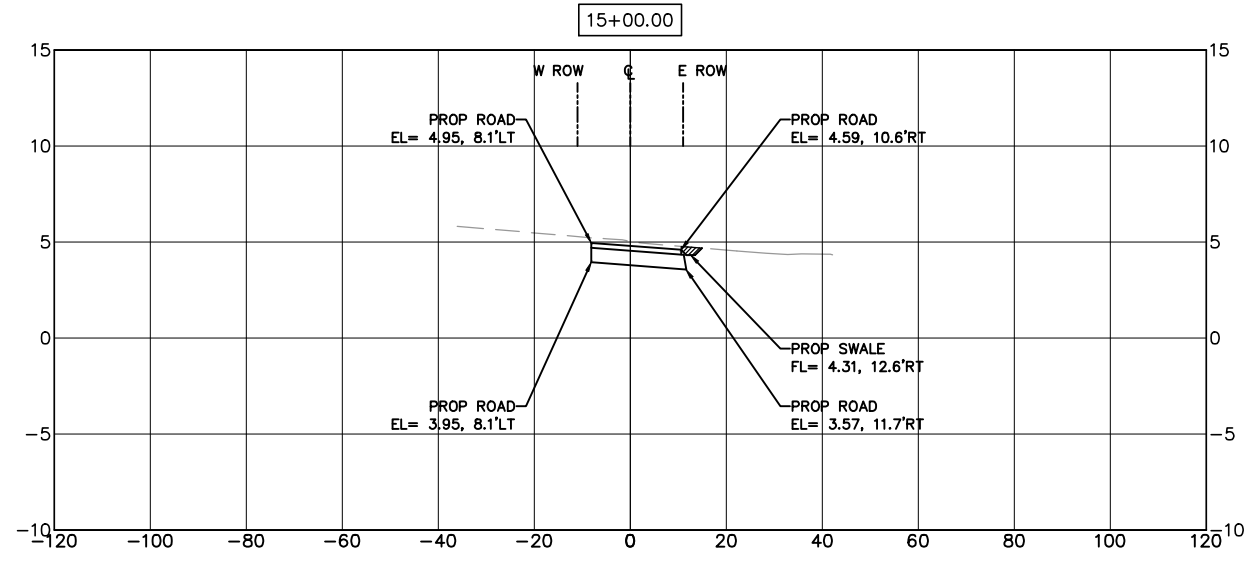
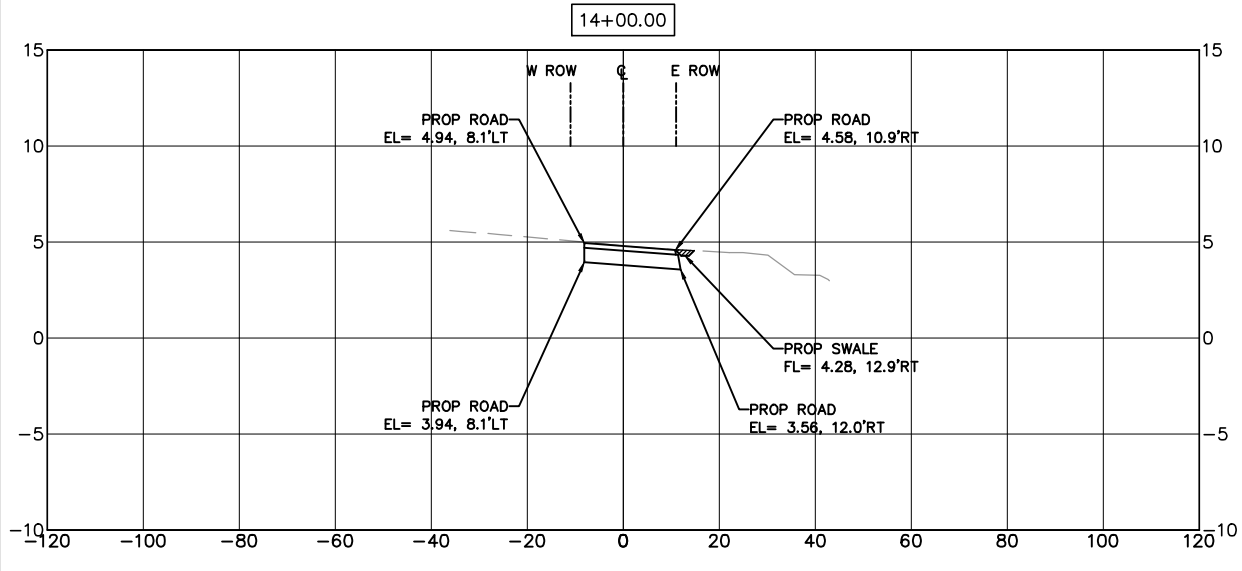
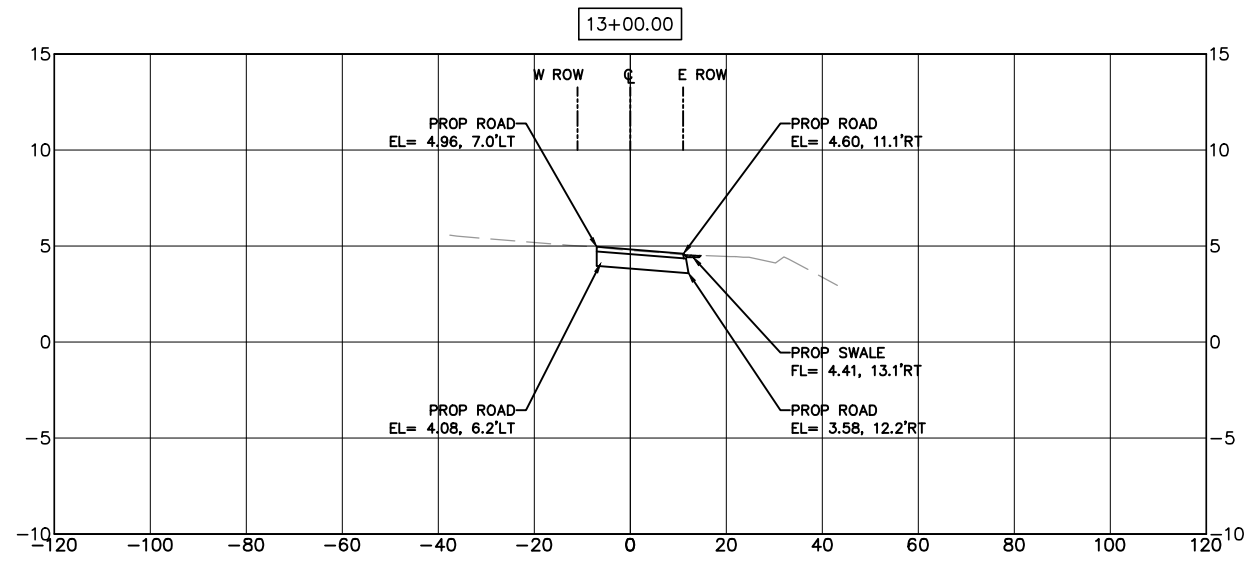
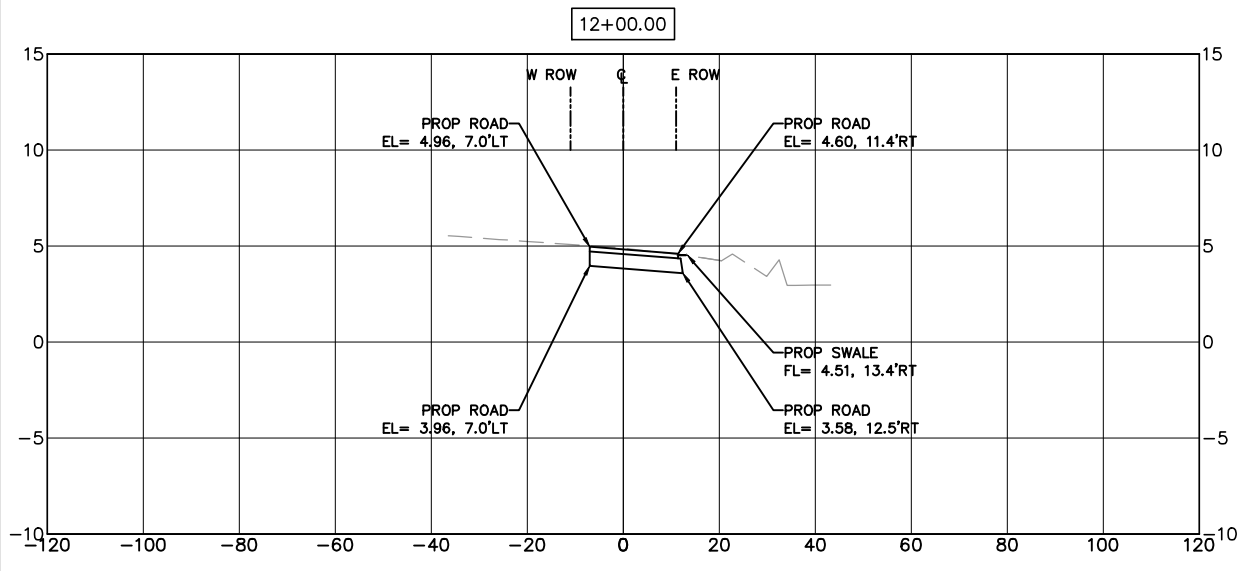

SHEET 3 OF 6

NO.	REVISIONS	DATE	NAME

**GALVESTON COUNTY
 ENGINEERING
 DEPARTMENT**





Zarinkel
 Engineering Services, Inc.
 817 Caroline St
 Houston, Texas 77002
 Ph: 832.242.2426
 Fax: 832.242.2445
 Firm Reg. # F-004270



PROJECT TITLE: BLUE HERON DRIVE		PROJECT ID: BV01
DRAWN BY:	SHEET DESCRIPTION: CROSS SECTIONS	
CK'D BY:		
SCALE:		
DATE: 9/10/2020	APPROVED BY:	SHEET NO: 22 / 30

FILE INFO: Z:\Galveston County\Blue Heron\04 CAD\20 - 25 C-005-001 CROSS SECTIONS.dwg PLOTTED BY: James Gaibort DATE: Sep 10, 2020 3:47pm

LEGEND:
 CUT 
 FILL 

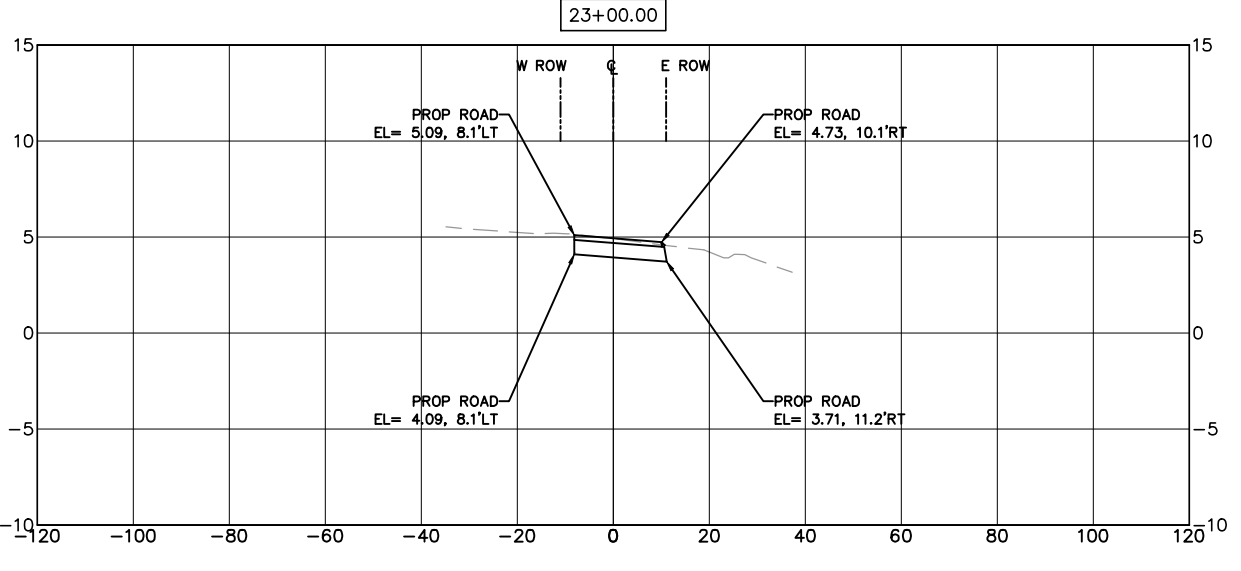
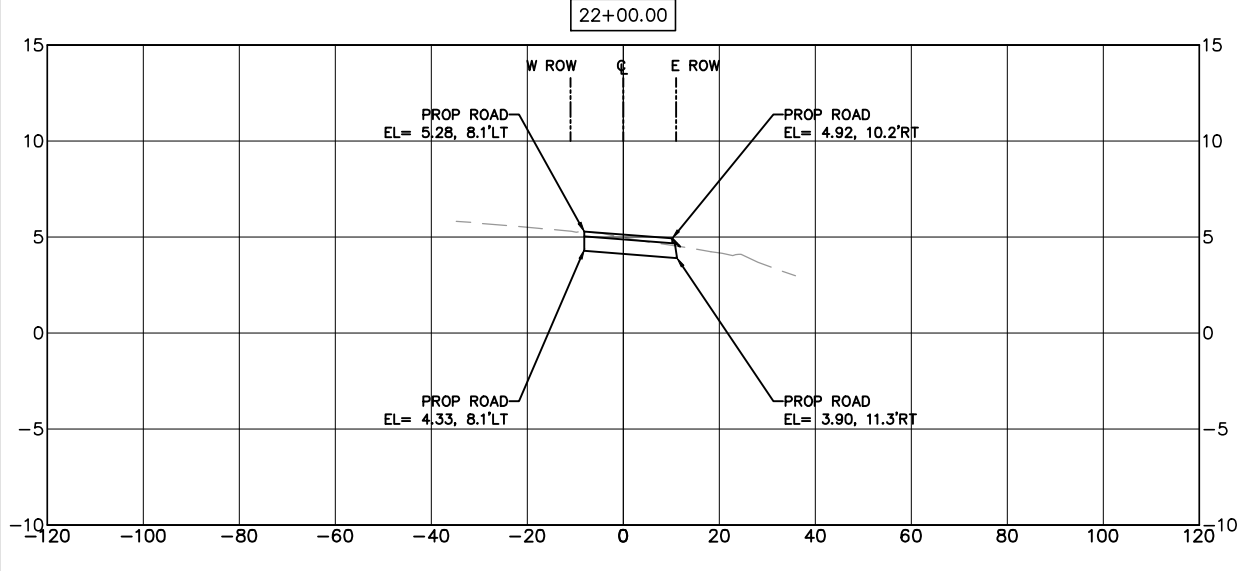
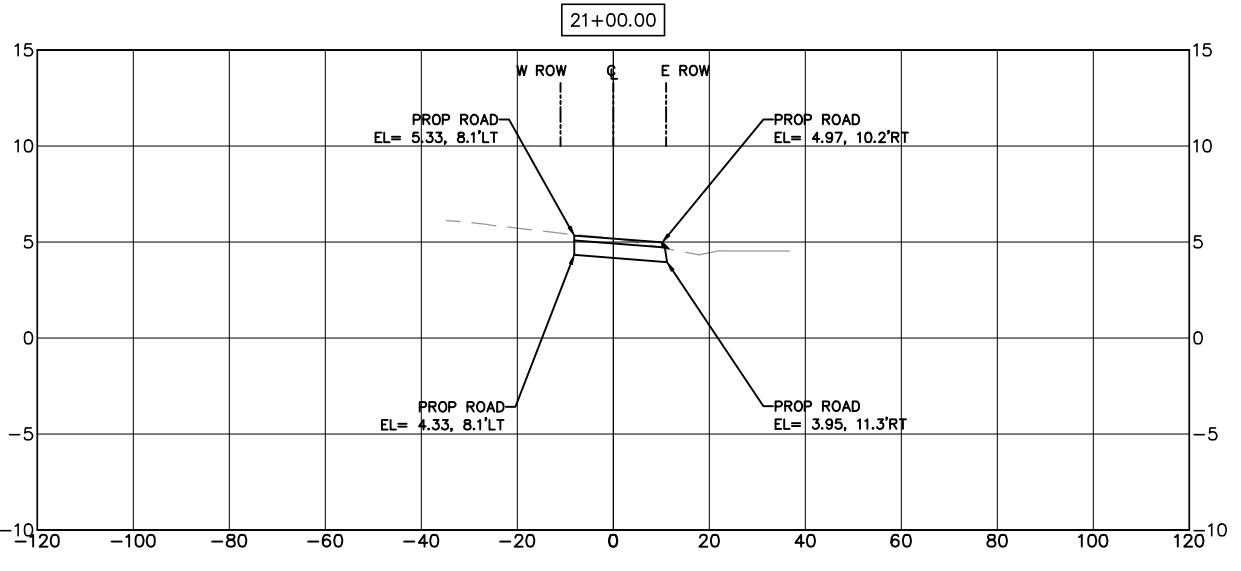
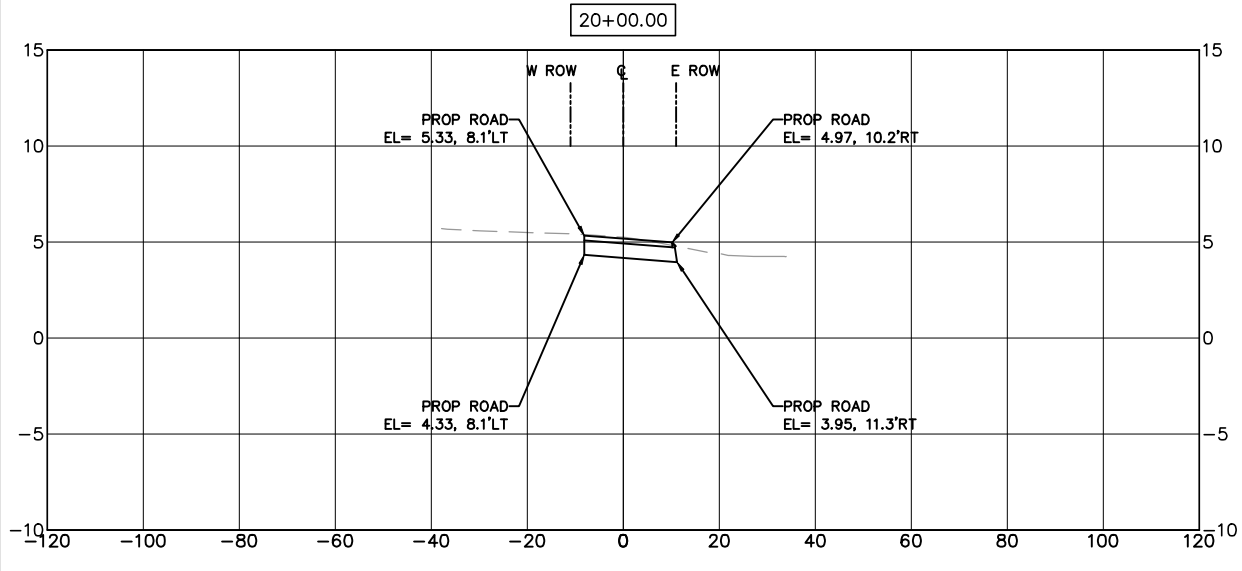
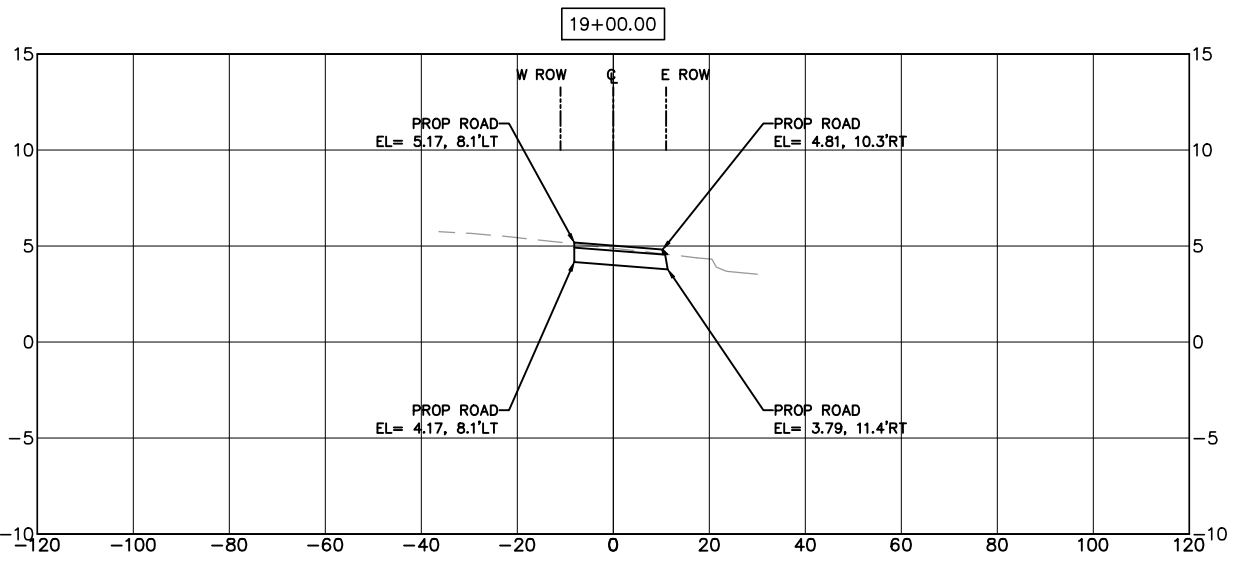
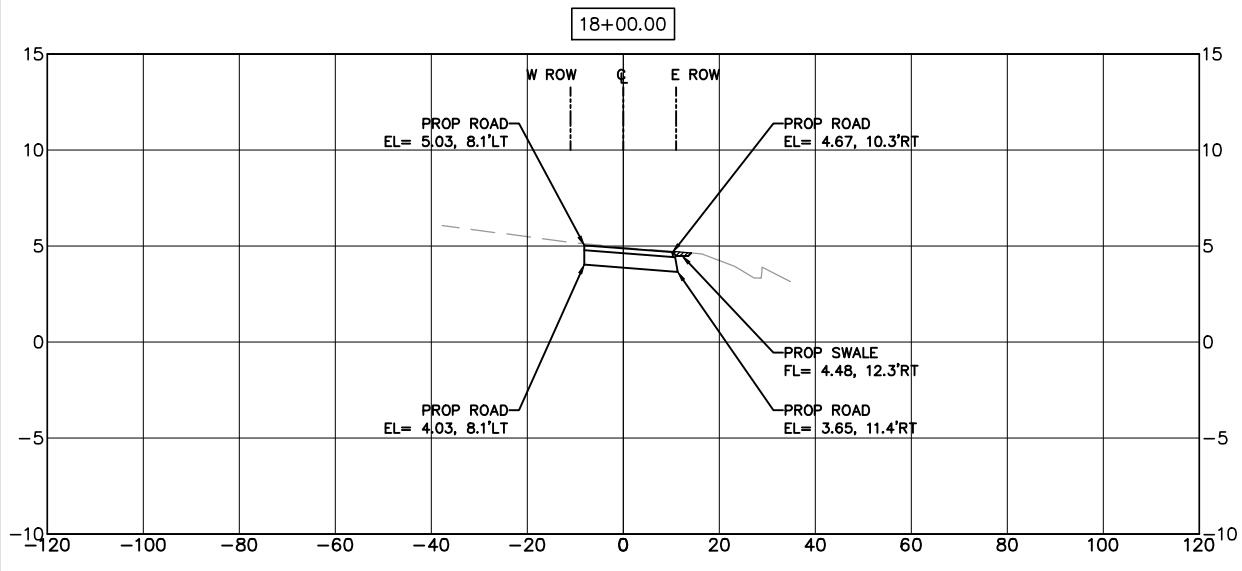

SHEET 4 OF 6

NO.	REVISIONS	DATE	NAME

**GALVESTON COUNTY
 ENGINEERING
 DEPARTMENT**





Zarinkel
 Engineering Services, Inc.
 817 Caroline St
 Houston, Texas 77002
 Ph: 832.242.2426
 Fax: 832.242.2445
 Firm Reg. # F-004270

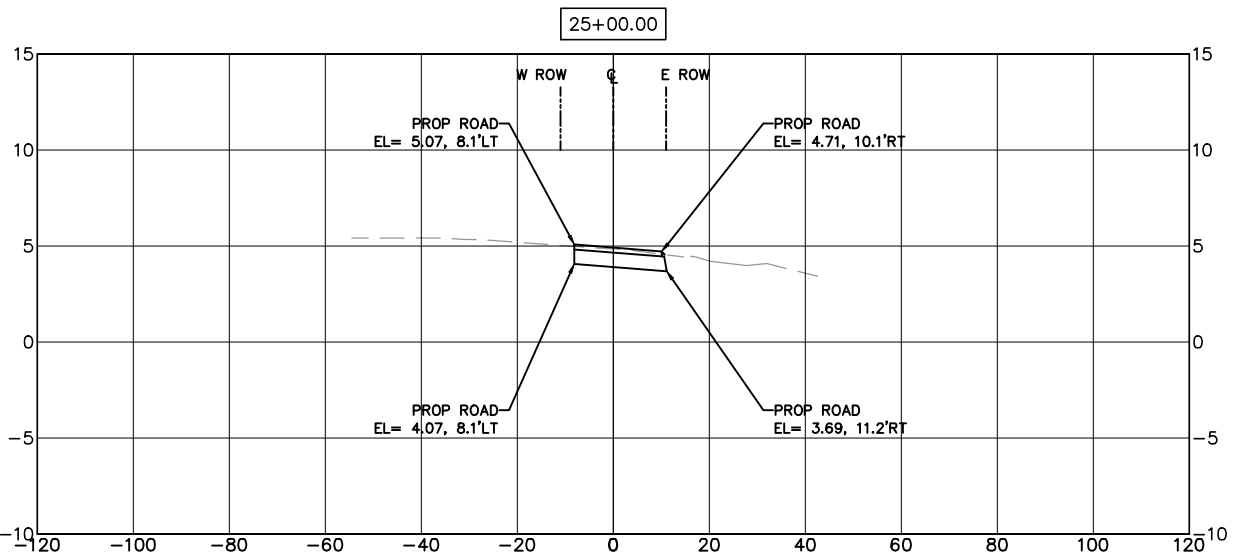
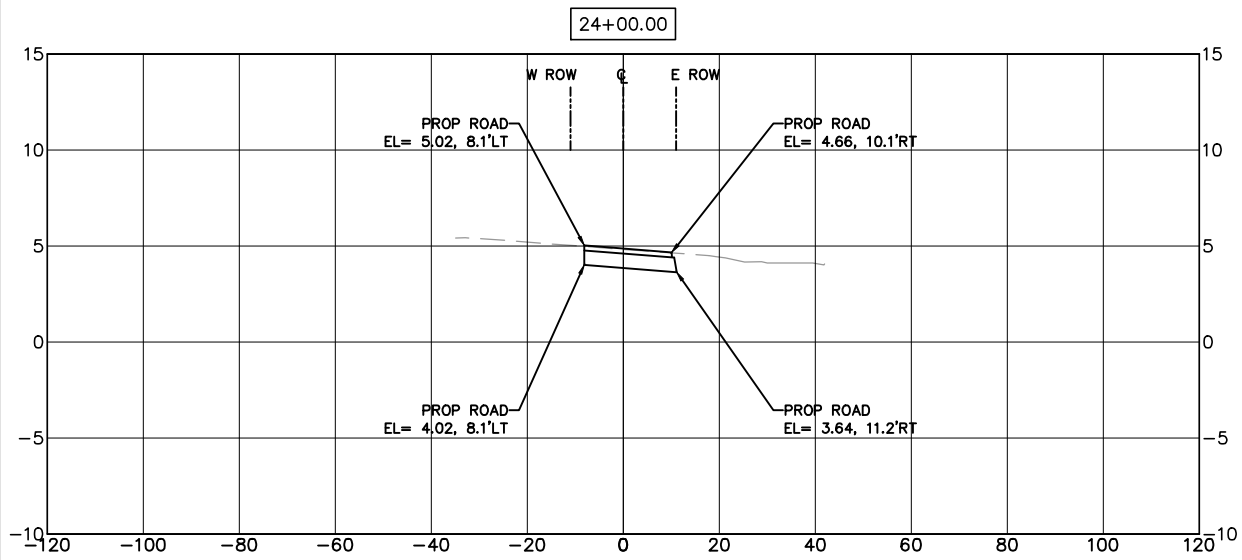

PROJECT TITLE: BLUE HERON DRIVE		PROJECT ID: BV01
DRAWN BY:	SHEET DESCRIPTION: CROSS SECTIONS	
CK'D BY:		
SCALE:		
DATE: 9/10/2020	APPROVED BY:	SHEET NO: 23 / 30

FILE INFO: Z:\Galveston County\Blue Heron\04 CAD\20 - 25 C-005-001 CROSS SECTIONS.dwg PLOTTED BY: James Gaibort DATE: Sep 10, 2020 3:48pm



LEGEND:
 CUT 
 FILL 

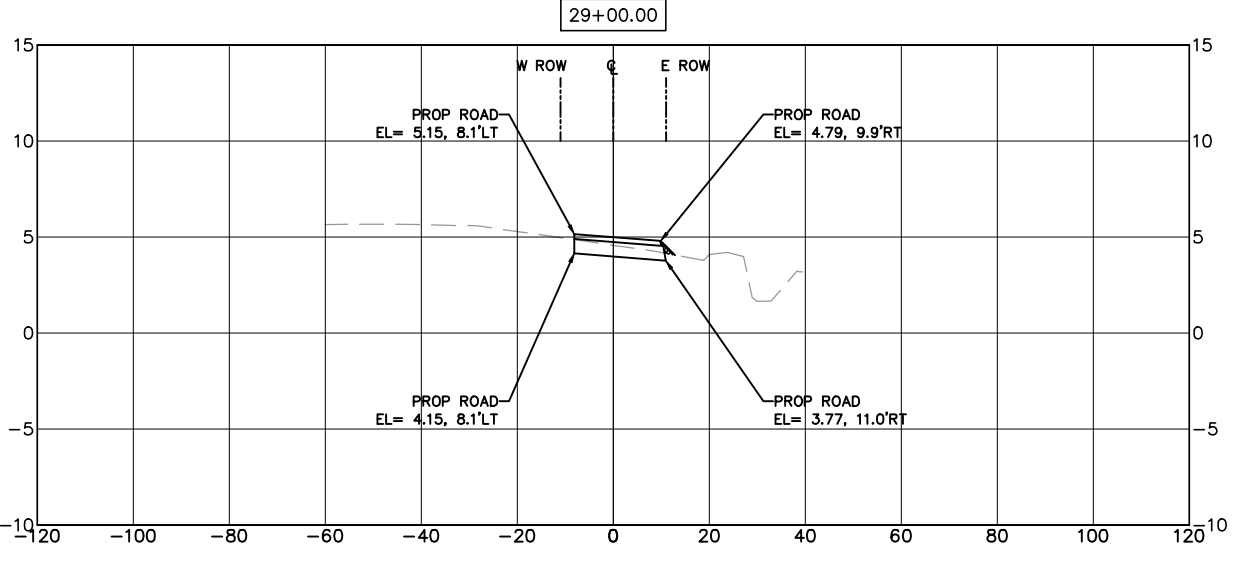
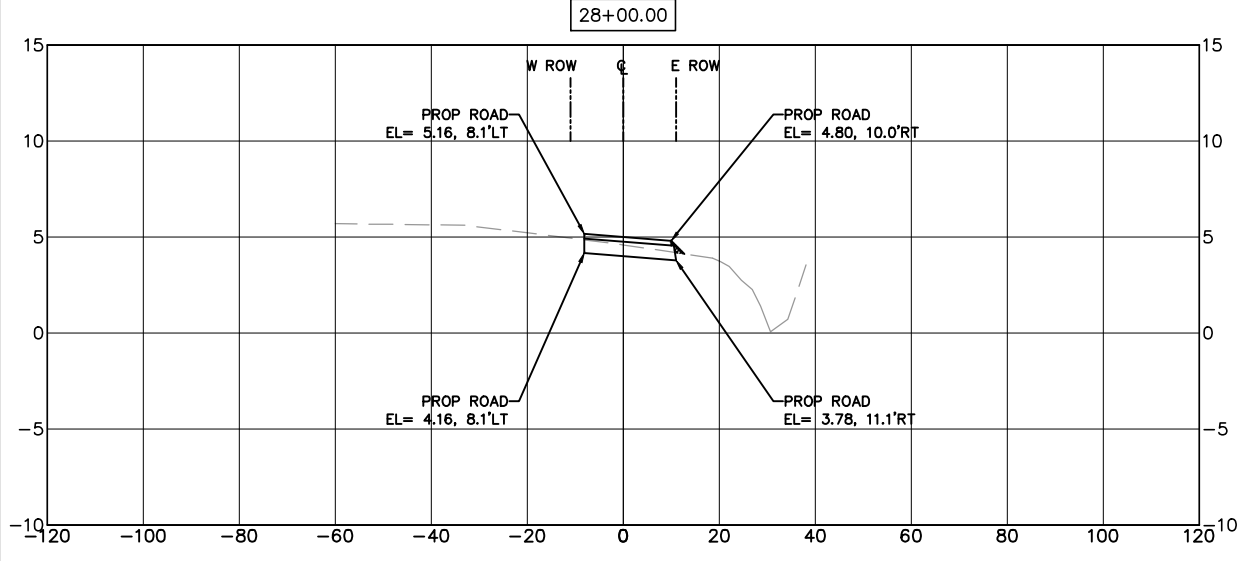
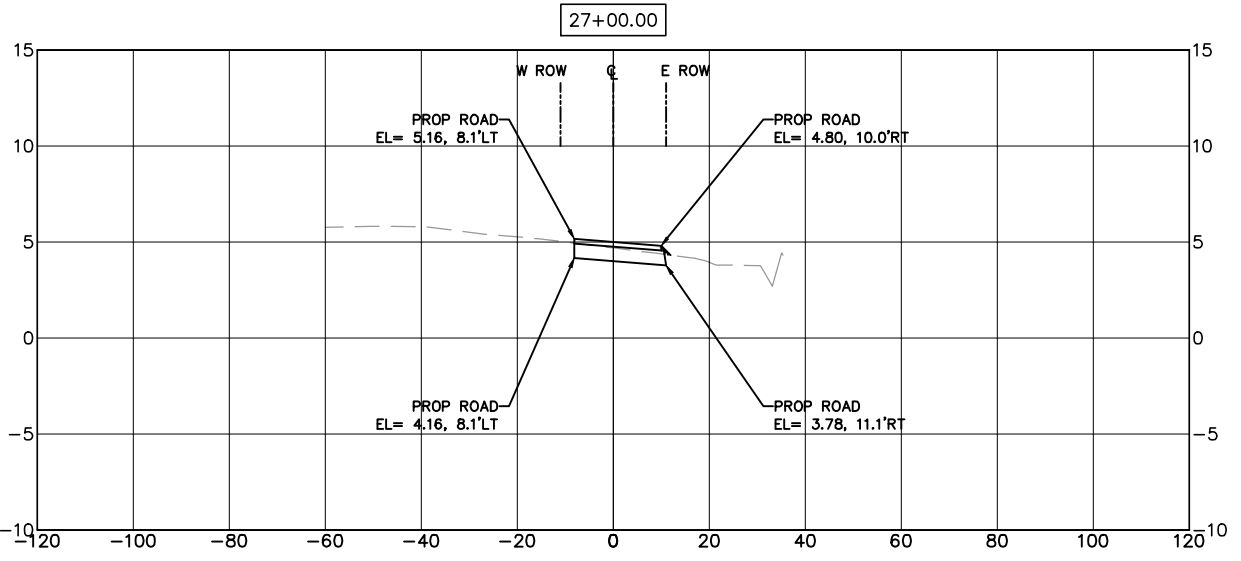
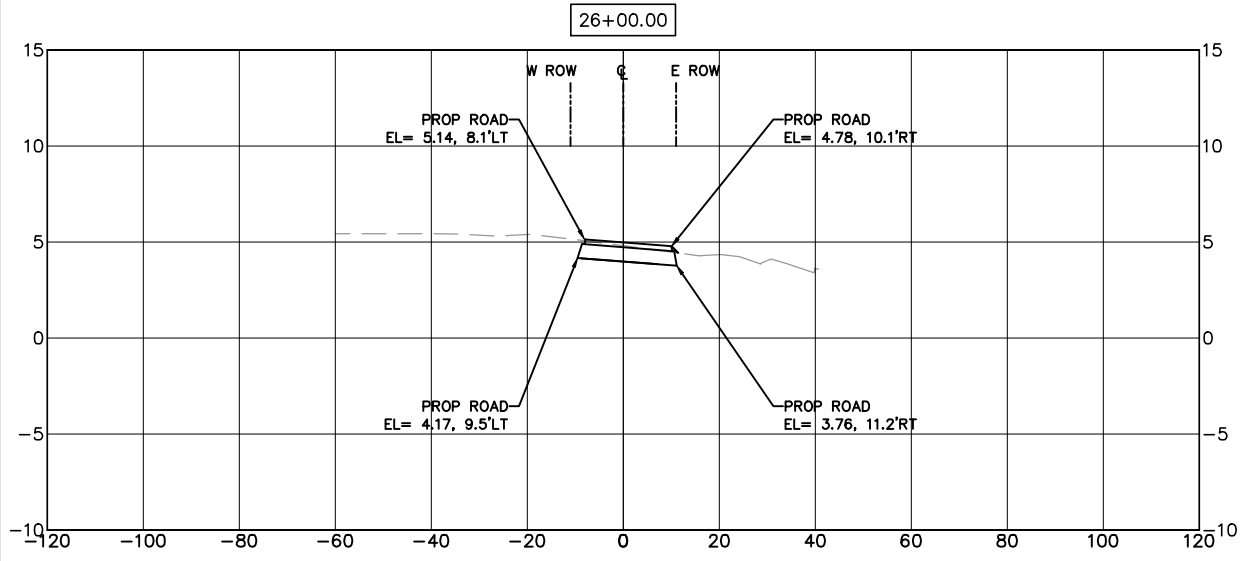

SHEET 5 OF 6

NO.	REVISIONS	DATE	NAME

**GALVESTON COUNTY
 ENGINEERING
 DEPARTMENT**





Zarinkel
 Engineering Services, Inc.
 817 Caroline St
 Houston, Texas 77002
 Ph: 832.242.2426
 Fax: 832.242.2445
 Firm Reg. # F-004270



PROJECT TITLE: BLUE HERON DRIVE		PROJECT ID: BV01
DRAWN BY:	SHEET DESCRIPTION: CROSS SECTIONS	
CK'D BY:		
SCALE:		
DATE: 9/10/2020	APPROVED BY:	SHEET NO: 24 / 30

FILE INFO: Z:\Galveston County\Blue Heron\04 CAD\20 - 25 C-005-001 CROSS SECTIONS.dwg PLOTTED BY: James Gaibort DATE: Sep 10, 2020 3:48pm

LEGEND:
 CUT 
 FILL 

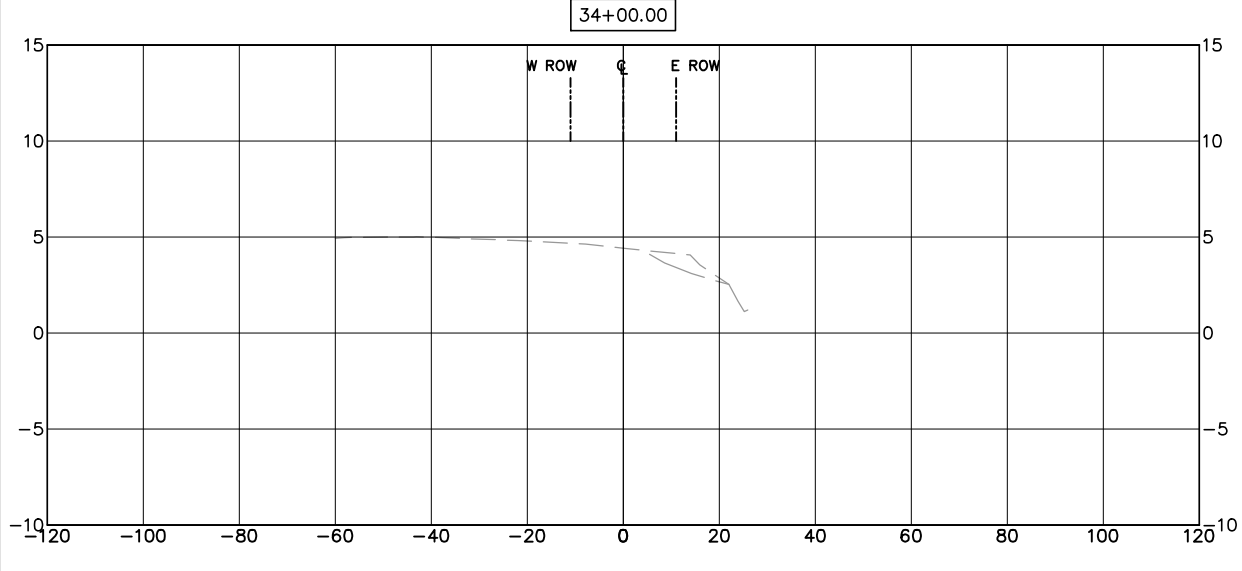
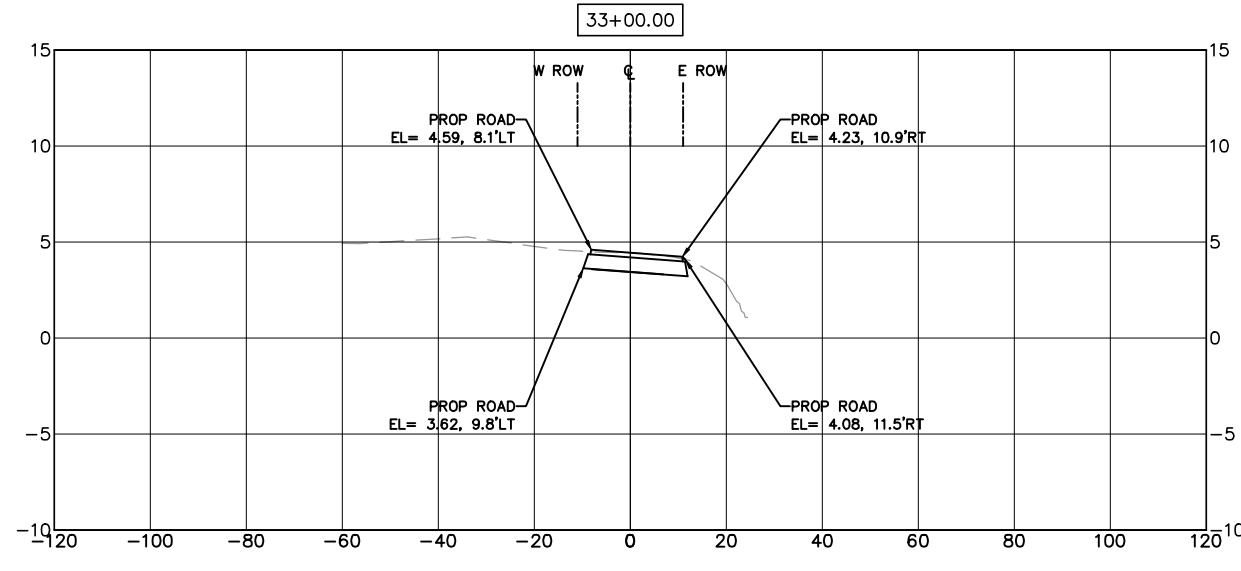
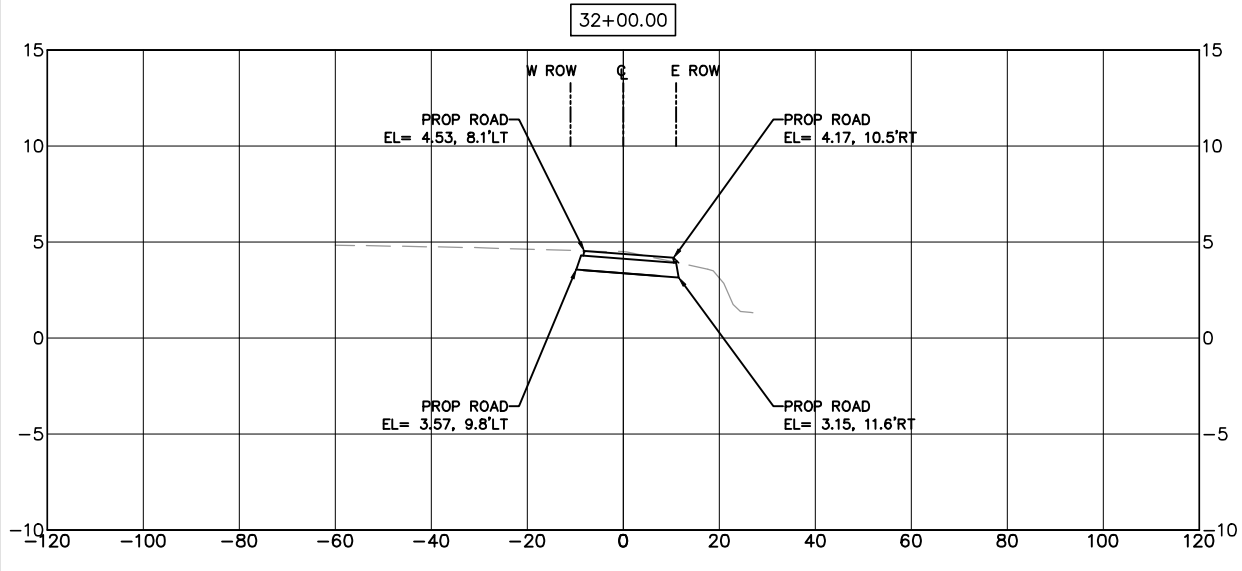
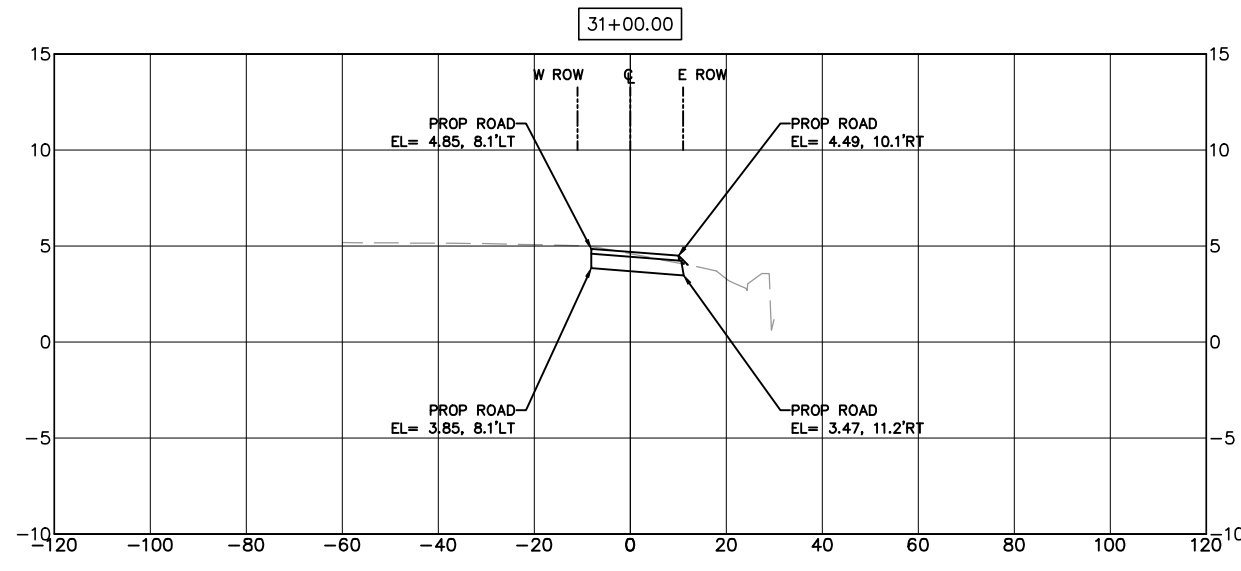
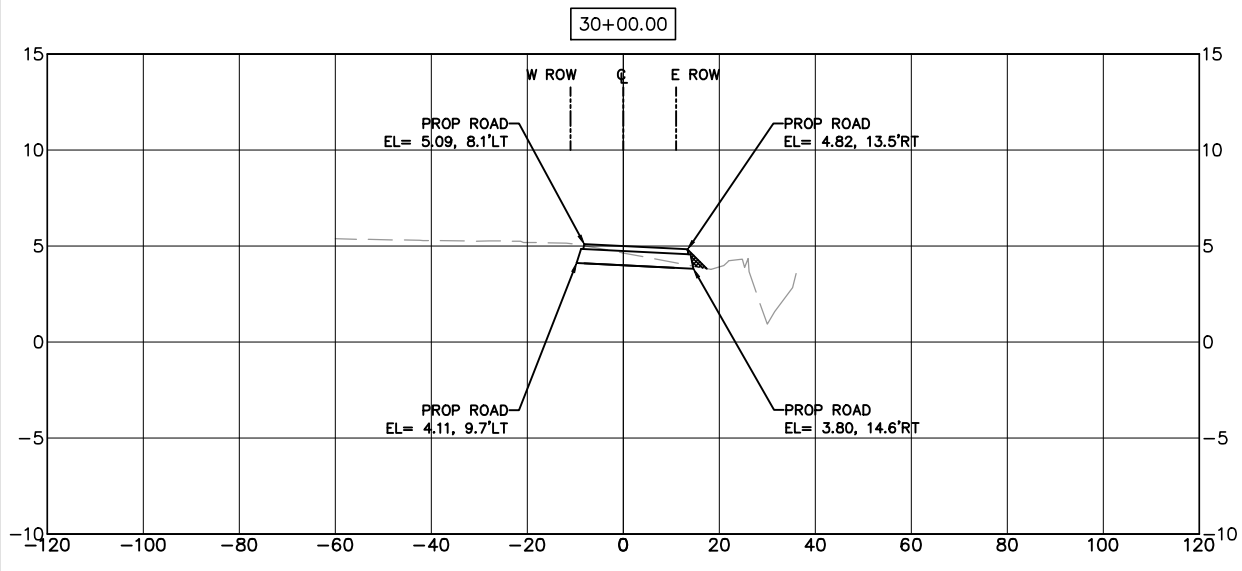

SHEET 6 OF 6

NO.	REVISIONS	DATE	NAME

**GALVESTON COUNTY
 ENGINEERING
 DEPARTMENT**



Zarinkel
 Engineering Services, Inc.
 817 Caroline St
 Houston, Texas
 Ph: 832.242.2426
 Fax: 832.242.2445
 Firm Reg. # F-004270



PROJECT TITLE: BLUE HERON DRIVE		PROJECT ID: BV01
DRAWN BY:	SHEET DESCRIPTION: CROSS SECTIONS	SHEET NO: 25 / 30
CK'D BY:		
SCALE:		
DATE: 9/10/2020	APPROVED BY:	

FILE INFO: Z:\Galveston County\Blue Heron\04 CAD\26 BORING LOGS SHEET 1 OF 4.dwg PLOTTED BY: James Gaibort DATE: Sep 10, 2020 3:48pm

LOG OF BORINGS														
Project: Blue Heron Drive Bayou Vista Galveston County, Texas Client: Zarinkel Engineering Services, Inc. Houston, Texas							Project No.: 19-1088 Boring Number: 1 Surface Elevation: Drilled: 11/18/19 Sheet 1 of 1							
Soil Symbol	Depth, ft	Sample Interval, Sampler Type	Penetration Resistance, P, tsf Standard Penetration Test N, blows/ft or blows/interval	Moisture Content, %	LABORATORY DATA			Dry Density, lb/ft ³	Undrained Shear Strength, c _v lb/ft ²	Failure Strain, %	Confining Pressure, lb/in ²	Comment	Drilling Method(s): Dry-auger drilling: 0 ft to 10 ft	
					ATTERBERG LIMITS									
					LL	PL	PI							
													Borehole Water Levels: First encountered After elapsed	No water encountered
DESCRIPTION OF STRATUM														
	1		P = 0.75	24.0	50	19	31							ASPHALT PAVING: 2 3/4 inches. CEMENT STABILIZED SAND AND GRAVEL BASE: 10 1/4 inches.
	2		P = 0.25	43.8										FILL: Gray and brown, fat clay with ferrous stains.
	3													FAT CLAY (CH): Very soft, light brown and gray with ferrous stains. - with root fibers, 2 to 6 ft.
	4		P = 0	58.0	87	27	60							
	5													
	6		P = 0	48.9				67	240	14.3	8			Bulge, Vertical Fracture, Slickensided
	7													
	8		P = 0	42.2	58	23	35							
	9													
	10													Borehole terminated at 10-ft depth
Remarks:														

LOG OF BORINGS														
Project: Blue Heron Drive Bayou Vista Galveston County, Texas Client: Zarinkel Engineering Services, Inc. Houston, Texas							Project No.: 19-1088 Boring Number: 2 Surface Elevation: Drilled: 11/18/19 Sheet 1 of 1							
Soil Symbol	Depth, ft	Sample Interval, Sampler Type	Penetration Resistance, P, tsf Standard Penetration Test N, blows/ft or blows/interval	Moisture Content, %	LABORATORY DATA			Dry Density, lb/ft ³	Undrained Shear Strength, c _v lb/ft ²	Failure Strain, %	Confining Pressure, lb/in ²	Comment	Drilling Method(s): Dry-auger drilling: 0 ft to 10 ft	
					ATTERBERG LIMITS									
					LL	PL	PI							
													Borehole Water Levels: First encountered After elapsed	5.0 ft 4.0 ft
DESCRIPTION OF STRATUM														
	1		P = 0.25	34.8										ASPHALT PAVING: 2 1/2 inches. CEMENT STABILIZED SAND AND GRAVEL BASE: 10 1/2 inches.
	2		P = 0.25	40.7	63	27	36							FILL: Light brown and dark brown, fat clay with ferrous stains.
	3													FAT CLAY (CH): Very soft, brown an gray with ferrous stains.
	4		P = 0	37.2					82	370	11.1	6		Bulge, Vertical Fracture, Slickensided
	5													
	6		P = 0	49.1	70	25	45							
	7													
	8		P = 0	49.1										
	9													
	10													Borehole terminated at 10-ft depth
Remarks:														

NO.	REVISIONS	DATE	NAME

GALVESTON COUNTY
ENGINEERING
DEPARTMENT



Zarinkel
Engineering Services, Inc.
617 Caroline St.
Houston, Texas 77002
Ph: 832.242.2426
Fax: 832.242.2445
Firm Reg. # F-004270



PROJECT TITLE: BLUE HERON DRIVE		PROJECT ID: BV01
DRAWN BY:	SHEET DESCRIPTION: BORING LOGS	SHEET NO: 26 / 30
CK'D BY:	APPROVED BY:	
SCALE:	DATE: 9/10/2020	

FILE INFO: Z:\Galveston County\Blue Heron\04 CAD\27 BORING LOGS SHEET 2 OF 4.dwg PLOTTED BY: James Gaibart DATE: Sep 10, 2020 3:48pm

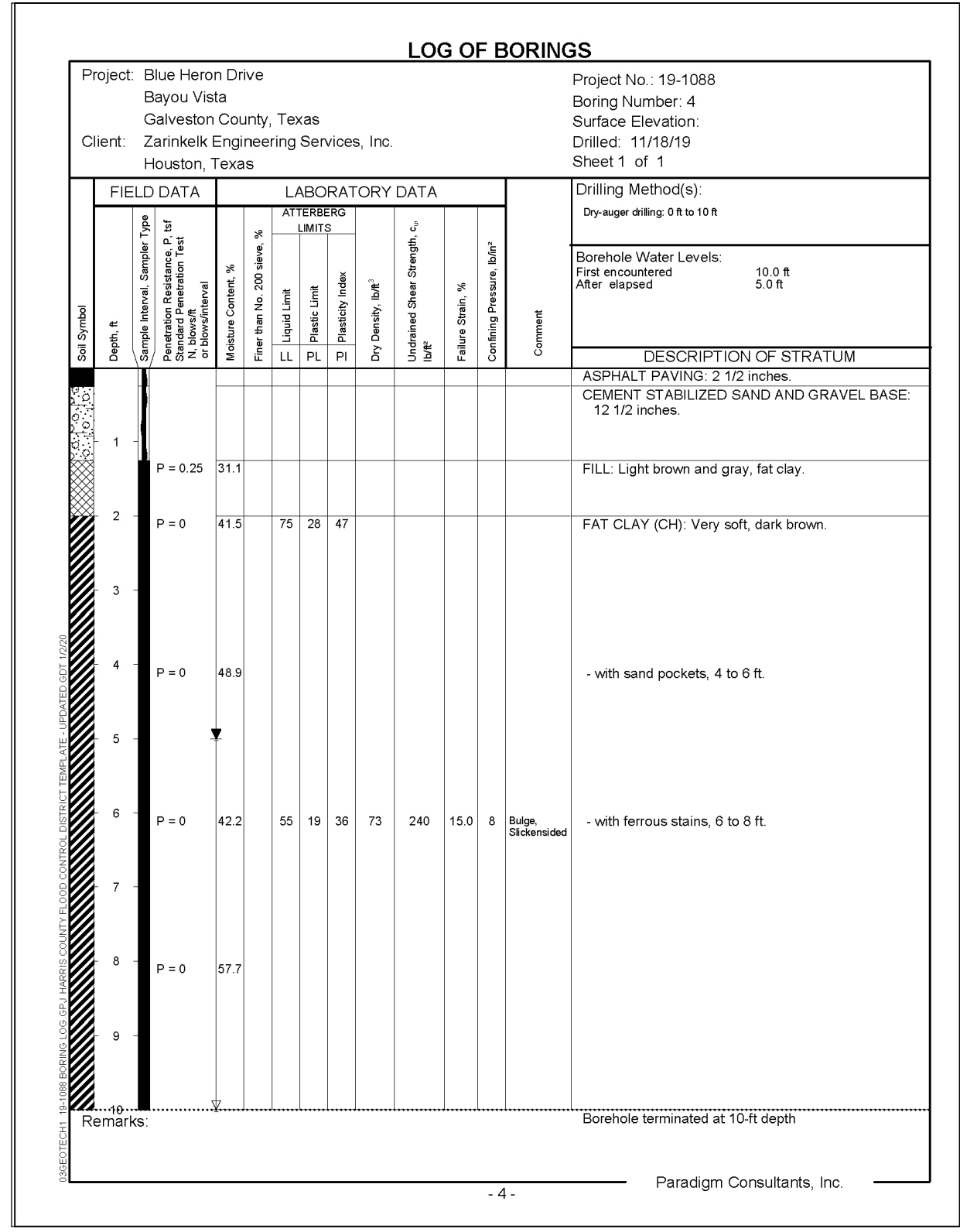
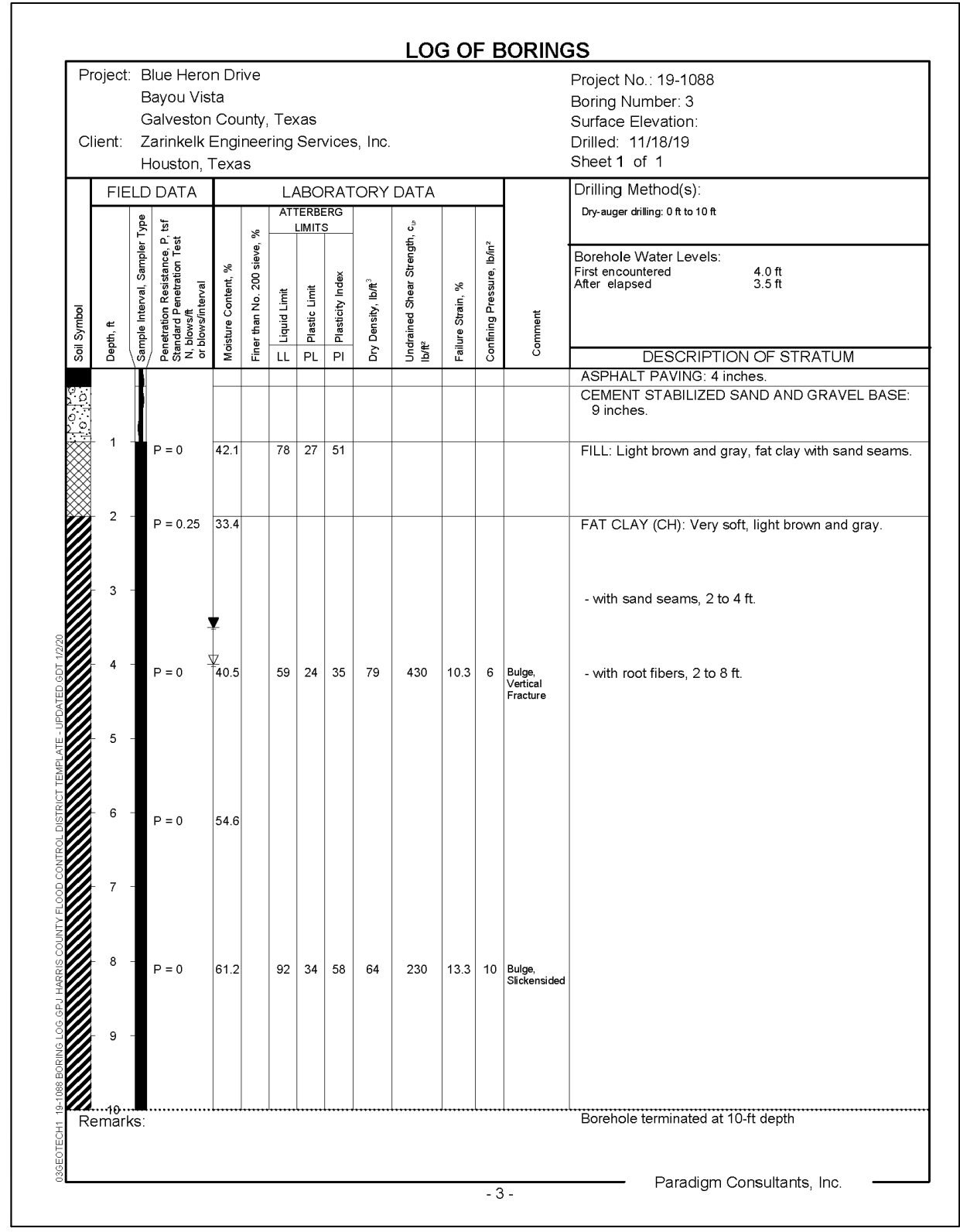

NO.	REVISIONS	DATE	NAME

**GALVESTON COUNTY
ENGINEERING
DEPARTMENT**



Zarinkel
Engineering Services, Inc.
617 Caroline St.
Houston, Texas 77002
Ph: 832.242.2426
Fax: 832.242.2445
Firm Reg. # F-004270



PROJECT TITLE: BLUE HERON DRIVE		PROJECT ID: BV01
DRAWN BY:	SHEET DESCRIPTION: BORING LOGS	SHEET NO: 27 / 30
CK'D BY:	APPROVED BY:	
SCALE:	DATE: 9/10/2020	

FILE INFO: Z:\Galveston County\Blue Heron\04 CAD\28 BORING LOGS SHEET 3 OF 4.dwg PLOTTED BY: James Gaibart DATE: Sep 10, 2020 3:48pm

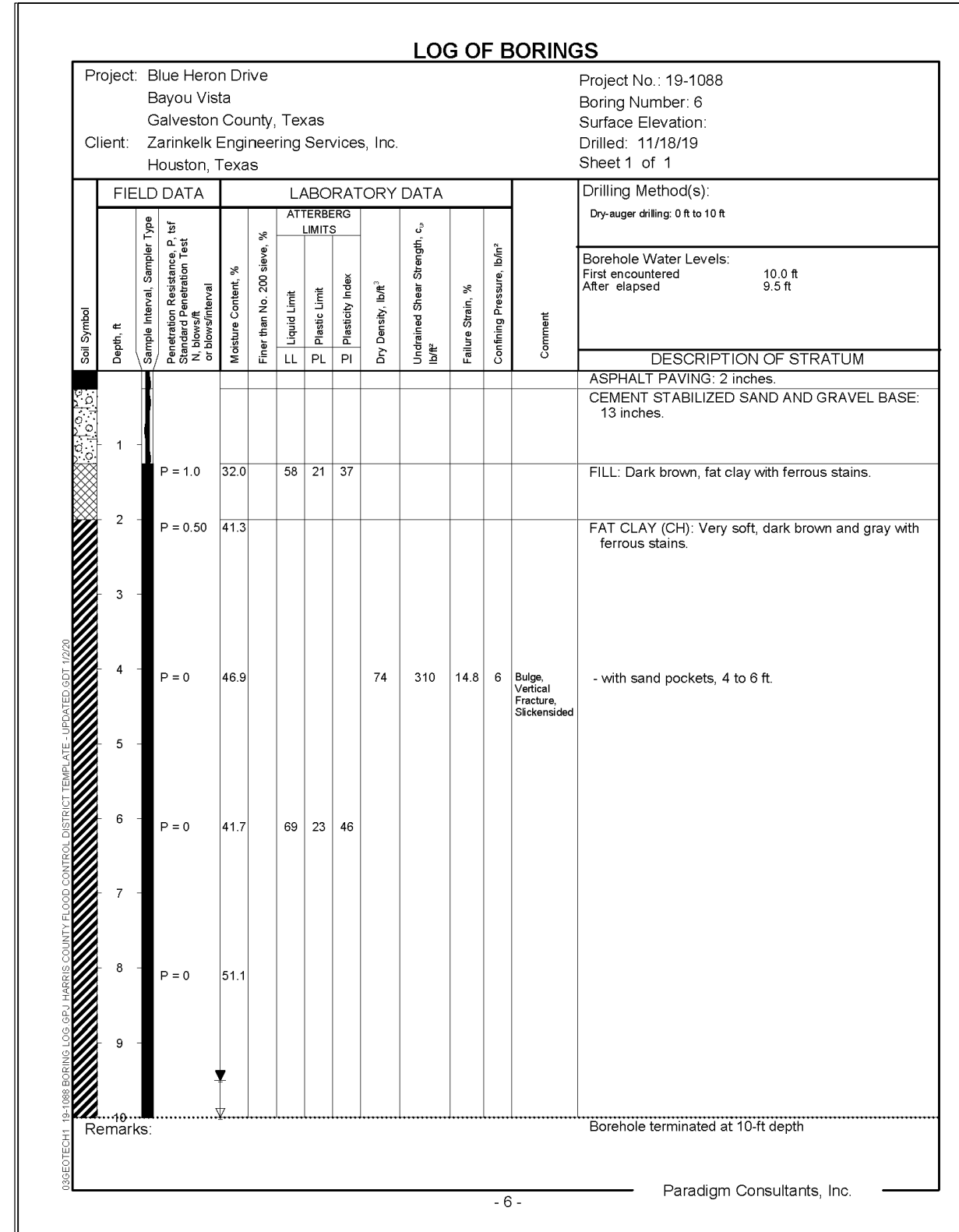
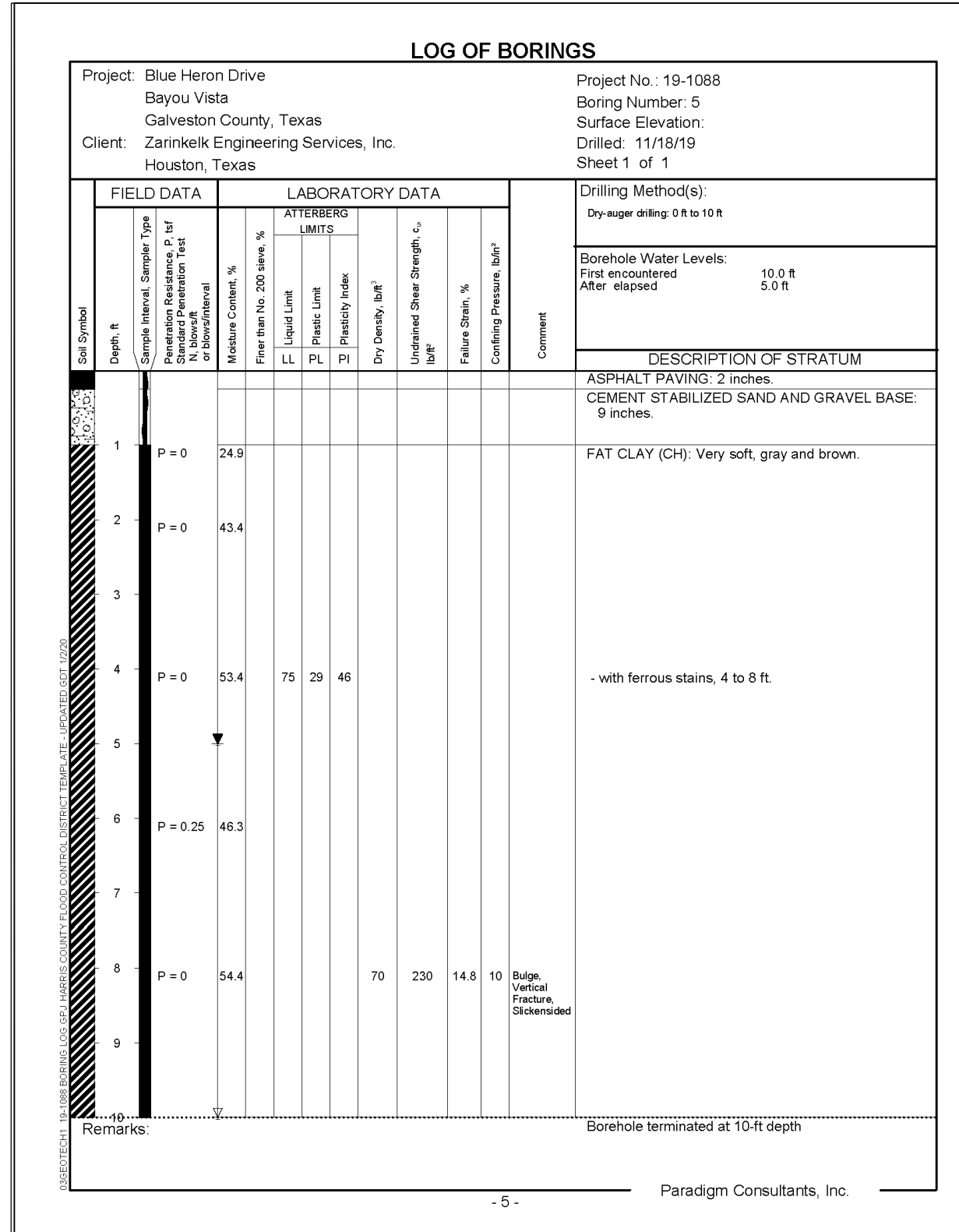

SHEET 3 OF 4

NO.	REVISIONS	DATE	NAME

**GALVESTON COUNTY
ENGINEERING
DEPARTMENT**



Zarinkel
Engineering Services, Inc.
617 Caroline St.
Houston, Texas 77002
Ph: 832.242.2426
Fax: 832.242.2445
Firm Reg. # F-004270



PROJECT TITLE: BLUE HERON DRIVE		PROJECT ID: BV01
DRAWN BY:	SHEET DESCRIPTION: BORING LOGS	SHEET NO: 28 / 30
CK'D BY:	APPROVED BY:	
SCALE:	DATE: 9/10/2020	

FILE INFO: Z:\Galveston County\Blue Heron\04 CAD\29 BORING LOGS SHEET 4 OF 4.dwg PLOTTED BY: James Gaibort DATE: Sep 10, 2020 3:48pm

LOG OF BORINGS

Project: Blue Heron Drive
 Bayou Vista
 Galveston County, Texas
 Client: Zarinkel Engineering Services, Inc.
 Houston, Texas

Project No.: 19-1088
 Boring Number: 7
 Surface Elevation:
 Drilled: 11/18/19
 Sheet 1 of 1

Soil Symbol	FIELD DATA				LABORATORY DATA						Drilling Method(s): Dry-auger drilling: 0 ft to 10 ft	Borehole Water Levels: First encountered 6.0 ft After elapsed 5.0 ft	Comment	DESCRIPTION OF STRATUM
	Depth, ft	Sample Interval, Sampler Type	Penetration Resistance, P, 1st Standard Penetration Test N, blows/ft or blows/interval	Moisture Content, %	Finer than No. 200 sieve, %	ATTERBERG LIMITS			Dry Density, lb/ft ³	Undrained Shear Strength, c _u , lb/ft ²				
					LL	PL	PI							
	0													ASPHALT PAVING: 2 3/4 inches.
	1		P = 0	11.5										CEMENT STABILIZED SAND AND GRAVEL BASE: 12 1/4 inches.
	2		P = 1.25	23.8	58	19	39							FILL: Light brown and dark brown, fat clay with sand layer.
	3													
	4		P = 0.50	42.4										FAT CLAY (CH): Very soft, light brown and dark brown with ferrous stains.
	5													
	6		P = 0	45.6	68	24	44							
	7													
	8		P = 0.50	38.4				81	590	11.6	10	Bulge, Vertical Fracture, Stickensided		
	9													
	10													Borehole terminated at 10-ft depth

Remarks: Borehole terminated at 10-ft depth

NO.	REVISIONS	DATE	NAME

**GALVESTON COUNTY
 ENGINEERING
 DEPARTMENT**



Zarinkel
 Engineering Services, Inc.
 617 Caroline St
 Houston, Texas 77002
 Ph: 832.242.2426
 Fax: 832.242.2445
 Firm Reg. # F-004270



PROJECT TITLE: BLUE HERON DRIVE		PROJECT ID: BV01
DRAWN BY:	SHEET DESCRIPTION: BORING LOGS	SHEET NO: 29 / 30
CK'D BY:	APPROVED BY:	
SCALE:	DATE: 9/10/2020	

FILE INFO: Z:\Galveston County\Blue Heron\04 CAD\30 PROJECT SIGN.dwg PLOTTED BY: James Galbort DATE: Sep 10, 2020 3:48pm

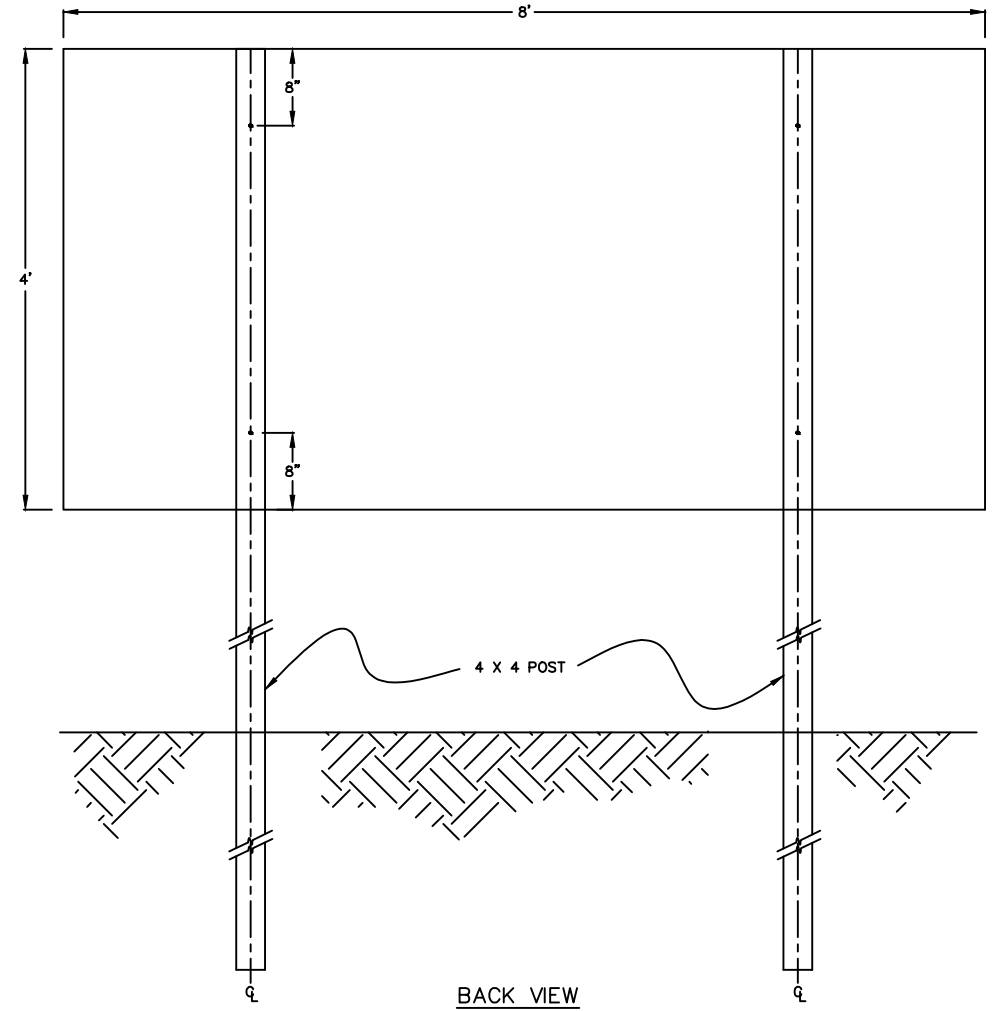
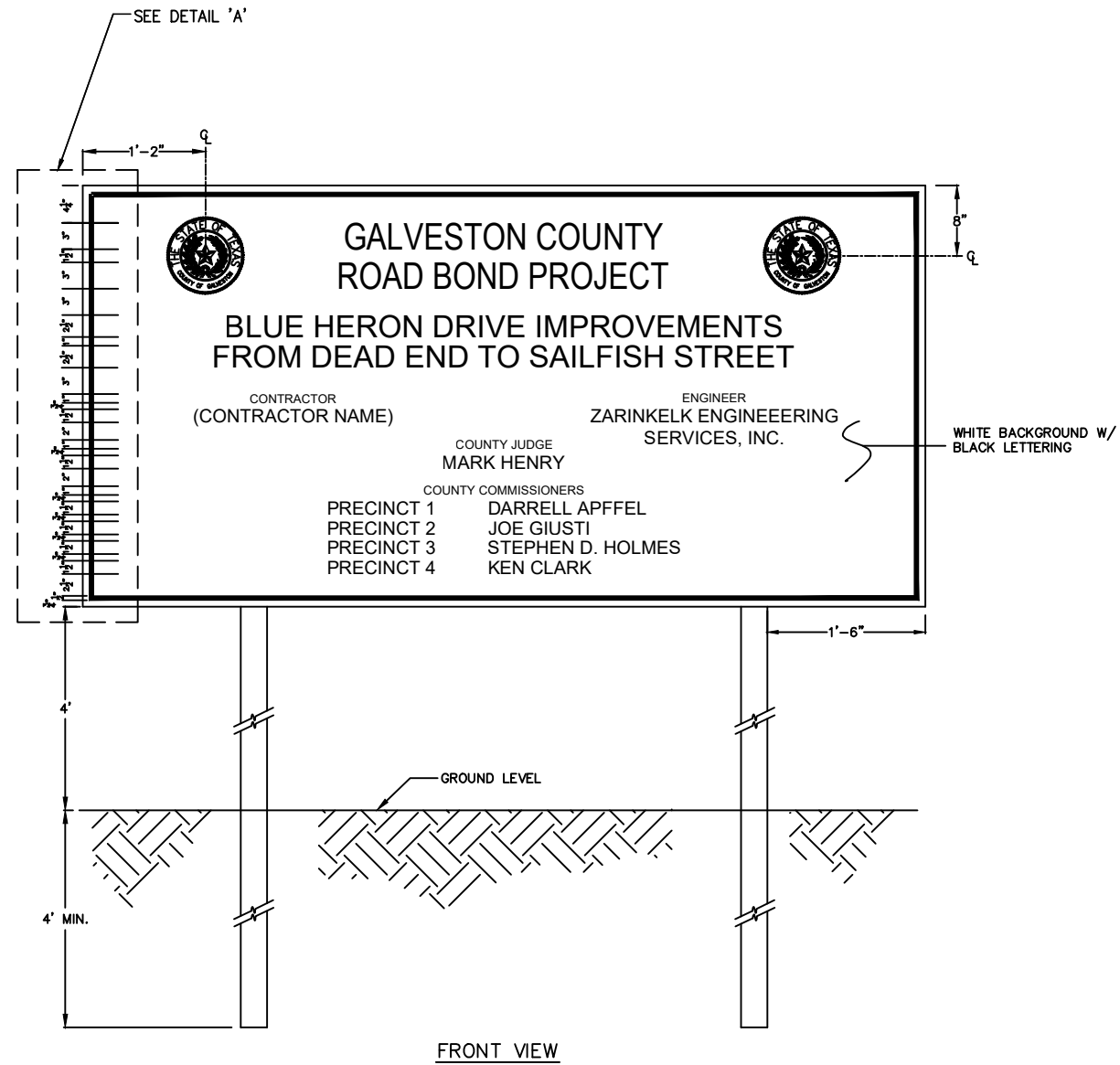
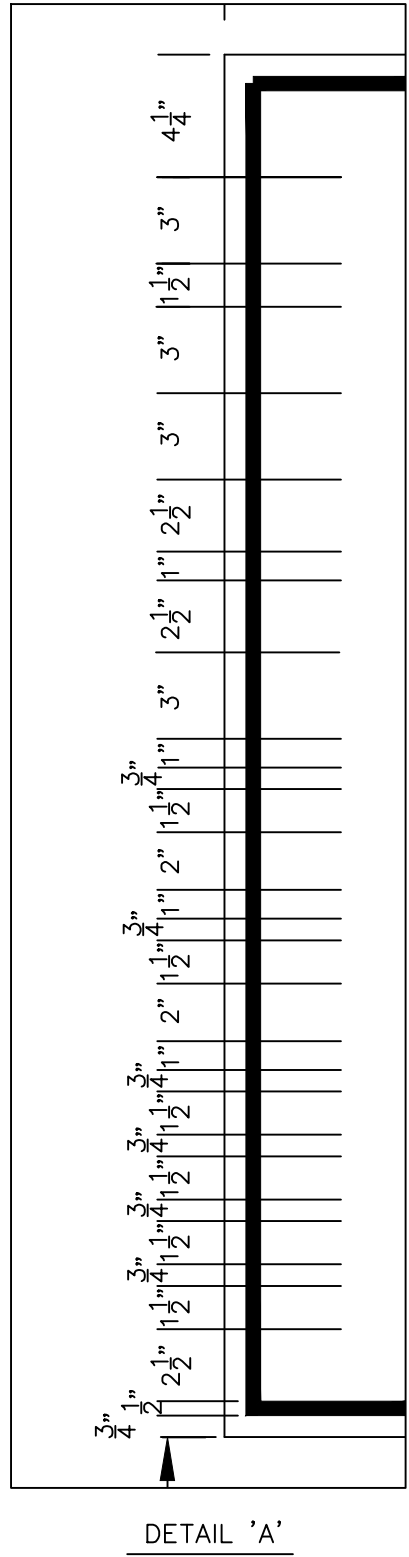

NO.	REVISIONS	DATE	NAME

**GALVESTON COUNTY
ENGINEERING
DEPARTMENT**

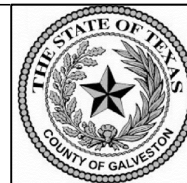

Zarinkelk
Engineering Services, Inc.
617 Caroline St
Houston, Texas 77002
Ph: 832.242.2426
Fax: 832.242.2445
Firm Reg. # F-004270

Giti Zarinkelk
8-11-2020

PROJECT TITLE: BLUE HERON DRIVE		PROJECT ID: BV01
DRAWN BY:	SHEET DESCRIPTION: PROJECT SIGN	SHEET NO: 30 / 30
CK'D BY:		
DATE: 9/10/2020	APPROVED BY:	



THE COUNTY OF GALVESTON

RUFUS G. CROWDER, CPPO, CPPB
PURCHASING AGENT

GWEN MCLAREN, CPPB
ASST. PURCHASING AGENT

COUNTY COURTHOUSE
722 Moody (21st Street)
Fifth (5th) Floor
GALVESTON, TEXAS 77550

October 15, 2020

PROJECT NAME: Blue Heron Drive Improvements

SOLICITATION NO: ITB #B201049

RE: ADDENDUM #1

To All Prospective Bidders:

The following information is being provided to aid in preparation of your bid submittal(s):

Question #1: *Base Material? (250⁰ F - 325⁰ F).*

Answer: Line Item No 8A has been added to the project bid proposal for 'Cold-In-Place Recycled Base'. SPEC 252 has also been added to address this line item.

Question #2: *A question was asked about the disposal of millings from the project.*

Answer: The contractor shall dispose of the asphaltic millings those shall be hauled to County Road and Bridge Yard at: 11730 State Highway 6, Santa Fe, TX.

The cost for the disposal of the existing pavement material is incidental to the unit item "REMOVE AND DISPOSE EXISTING ASPHALTIC SURFACE AND BASE MATERIAL (ALL DEPTHS)".

Question #3: *If hot-mix base than Geotextile fabric won't work.*

Answer: Line Item No 8A has been added to the project bid proposal for 'Cold-In-Place Recycled Base'. SPEC 252 has also been added to address this line item.

PROJECT MANUAL:

1. *Replace Entire Bid Proposal Set with Attached set of Bid Proposal Alternate 2 and Alternate 3 were added to accommodate for a concrete pavement section.*
2. *The following specs have been added:*
 - a. *Spec 220*
 - b. *Spec 221*
 - c. *Spec 252*
 - d. *Spec 360*

DRAWINGS:

1. *Sheet No. 2 - Added Alternate Typical Section for Concrete pavement*
2. *Sheet No. 4 - Replaced call outs for '9" cold-in-place black base' with '9" cold-in-place recycled base.*

As a reminder, all questions regarding this proposal must be submitted in writing to:

Rufus G. Crowder, CPPO CPPB
Galveston County Purchasing Agent
722 Moody, Fifth (5th) Floor
Galveston, Texas 77550
E-mail: purchasing.bids@co.galveston.tx.us

If you have any further questions regarding this bid, please address them to Rufus Crowder, CPPO CPPB, Purchasing Agent, via e-mail at purchasing.bids@co.galveston.tx.us, or contact the Purchasing Department at (409) 770-5371.

Please excuse us for any inconvenience that this may have caused.

Sincerely,



Rufus G. Crowder, CPPO CPPB
Purchasing Agent
Galveston County

ADDENDUM #1
BID PROPOSAL - BASE BID ITEMS
Blue Heron Drive Improvements
ADDENDUM #1

ITEM NO.	SPEC. NO.	DESCRIPTION	UNIT	QUAN.	UNIT PRICE IN WORDS	UNIT PRICE	TOTAL PRICE
BASE BID - SITE PREPARATION AND DRAINAGE							
1	110	EXCAVATION FOR ROADWAY	CY.	43	_____ DOLLARS AND _____ CENTS	\$	\$
2	500	REMOVE AND RELOCATE OF EXISTING TRAFFIC SIGN, MAIL BOX	LS	1	_____ DOLLARS AND _____ CENTS	\$	\$
3	501	TREE PROTECTION	LS	1	_____ DOLLARS AND _____ CENTS	\$	\$
4	PLAN	PROJECT SIGNS	EA.	1	_____ DOLLARS AND _____ CENTS	\$	\$
5	COH 02505	12" HDPE PIPE CROSS CULVERT	LF.	46	_____ DOLLARS AND _____ CENTS	\$	\$
6	472	STORM TYPE "A" INLET	EA.	3	_____ DOLLARS AND _____ CENTS	\$	\$
7	719 741	INLET PROTECTION BARRIER (IPB)	EA.	3	_____ DOLLARS AND _____ CENTS	\$	\$
TOTAL BASE BID SITE PREPARATION AND DRAINAGE ITEMS							
BASE BID - PAVING ITEMS (FROM PROJECT BEGIN TO STA 28+00)							
8	540	REMOVE AND DISPOSE EXISTING ASPHALTIC SURFACE AND BASE MATERIAL (ALL DEPTHS)	SY.	5,955	_____ DOLLARS AND _____ CENTS	\$	\$
9	221	HYDRATED LIME (3%)	TON	96	_____ DOLLARS AND _____ CENTS	\$	\$
10	223	FLY ASH (7%)	TON	214	_____ DOLLARS AND _____ CENTS	\$	\$
11	250	HMAC BLACK BASE COURSE	TON	530	_____ DOLLARS AND _____ CENTS	\$	\$
12	252	9-INCH COLD-IN-PLACE RECYCLED BASE COURSE	SY.	6,570	_____ DOLLARS AND _____ CENTS	\$	\$
13	310	TACK COAT (0.05 GAL/SY)	GAL	329	_____ DOLLARS AND _____ CENTS	\$	\$
14	340	3-INCH HMAC SURFACE COURSE	TON	971	_____ DOLLARS AND _____ CENTS	\$	\$
15	494	GEOTEXTILE - FURNISH AND INSTALL	SY.	6,554	_____ DOLLARS AND _____ CENTS	\$	\$
16	162	SODDING	SY.	1,640	_____ DOLLARS AND _____ CENTS	\$	\$
17	713	REINFORCED FILTER FABRIC BARRIER	LF.	2,800	_____ DOLLARS AND _____ CENTS	\$	\$
18	751	SWPPP INSPECTION AND MAINTENANCE	MO	2	_____ DOLLARS AND _____ CENTS	\$	\$
19	671	TRAFFIC CONTROL	MO	2	_____ DOLLARS AND _____ CENTS	\$	\$
TOTAL BASE BID PAVING ITEMS (FROM PROJECT BEGIN TO STA 28+00)							

ADDENDUM #1
BID PROPOSAL - BASE BID ITEMS
Blue Heron Drive Improvements
ADDENDUM #1

ITEM NO.	SPEC. NO.	DESCRIPTION	UNIT	QUAN.	UNIT PRICE IN WORDS	UNIT PRICE	TOTAL PRICE
BASE BID - SUPPLEMENTAL ITEMS							
20	130	BORROW	CY.	25	_____ DOLLARS AND _____ CENTS	\$	\$
21	433	CEMENT STABILIZED SAND BEDDING & BACKFILL	CY.	25	_____ DOLLARS AND _____ CENTS	\$	\$
22	436	WELL POINTING	LF	40	_____ DOLLARS AND _____ CENTS	\$	\$
TOTAL SUPPLEMENTAL ITEMS							
ALTERNATE BID 1 - PAVING ITEMS (FROM STA 28+00 TO PROJECT END)							
23	540	REMOVE AND DISPOSE EXISTING ASPHALTIC SURFACE AND BASE MATERIAL (ALL DEPTHS)	SY.	1,200	_____ DOLLARS AND _____ CENTS	\$	\$
24	221	HYDRATED LIME (3%)	TON	20	_____ DOLLARS AND _____ CENTS	\$	\$
25	223	FLY ASH (7%)	TON	44	_____ DOLLARS AND _____ CENTS	\$	\$
26	250	HMAC BLACK BASE COURSE	TON	106	_____ DOLLARS AND _____ CENTS	\$	\$
27	252	9-INCH COLD-IN-PLACE RECYCLED BASE COURSE	SY.	1,335	_____ DOLLARS AND _____ CENTS	\$	\$
28	310	TACK COAT (0.05 GAL/SY)	GAL	68	_____ DOLLARS AND _____ CENTS	\$	\$
29	340	3-INCH HMAC SURFACE COURSE	TON	196	_____ DOLLARS AND _____ CENTS	\$	\$
30	494	GEOTEXTILE - FURNISH AND INSTALL	SY.	1,320	_____ DOLLARS AND _____ CENTS	\$	\$
31	162	SODDING	SY.	250	_____ DOLLARS AND _____ CENTS	\$	\$
32	713	REINFORCED FILTER FABRIC BARRIER	LF.	580	_____ DOLLARS AND _____ CENTS	\$	\$
33	751	SWPPP INSPECTION AND MAINTENANCE	MO	1	_____ DOLLARS AND _____ CENTS	\$	\$
34	671	TRAFFIC CONTROL	MO	1	_____ DOLLARS AND _____ CENTS	\$	\$
TOTAL ALTERNATE BID 1 PAVING ITEMS (FROM STA 28+00 TO PROJECT END)							

ADDENDUM #1
BID PROPOSAL - BASE BID ITEMS
Blue Heron Drive Improvements
ADDENDUM #1

ITEM NO.	SPEC. NO.	DESCRIPTION	UNIT	QUAN.	UNIT PRICE IN WORDS	UNIT PRICE	TOTAL PRICE
ALTERNATE BID 2 - PAVING ITEMS (FROM PROJECT BEGIN TO STA 28+00)							
35	540	REMOVE AND DISPOSE EXISTING ASPHALTIC SURFACE AND BASE MATERIAL (ALL DEPTHS)	SY.	5,965	_____ DOLLARS AND _____ CENTS	\$	\$
36	220	8% LIME STABILIZED SUBGRADE	SY.	7,035	_____ DOLLARS AND _____ CENTS	\$	\$
37	221	HYDRATED LIME	TON	170	_____ DOLLARS AND _____ CENTS	\$	\$
38	360	REINFORCED CONCRETE PAVING (7")	SY.	5,800	_____ DOLLARS AND _____ CENTS	\$	\$
39	162	SODDING	SY.	1,640	_____ DOLLARS AND _____ CENTS	\$	\$
40	713	REINFORCED FILTER FABRIC BARRIER	LF.	2,800	_____ DOLLARS AND _____ CENTS	\$	\$
41	751	SWPPP INSPECTION AND MAINTENANCE	MO	2	_____ DOLLARS AND _____ CENTS	\$	\$
42	671	TRAFFIC CONTROL	MO	2	_____ DOLLARS AND _____ CENTS	\$	\$
TOTAL ALTERNATE BID 2 PAVING ITEMS (FROM PROJECT BEGIN TO STA 28+00)							
ALTERNATE BID 3 - PAVING ITEMS (FROM STA 28+00 TO PROJECT END)							
43	540	REMOVE AND DISPOSE EXISTING ASPHALTIC SURFACE AND BASE MATERIAL (ALL DEPTHS)	SY.	1,200	_____ DOLLARS AND _____ CENTS	\$	\$
44	220	8% LIME STABILIZED SUBGRADE	SY.	1,425	_____ DOLLARS AND _____ CENTS	\$	\$
45	221	HYDRATED LIME	TON	35	_____ DOLLARS AND _____ CENTS	\$	\$
46	360	REINFORCED CONCRETE PAVING (7")	SY.	1,175	_____ DOLLARS AND _____ CENTS	\$	\$
47	162	SODDING	SY.	250	_____ DOLLARS AND _____ CENTS	\$	\$
48	713	REINFORCED FILTER FABRIC BARRIER	LF.	580	_____ DOLLARS AND _____ CENTS	\$	\$
49	751	SWPPP INSPECTION AND MAINTENANCE	MO	1	_____ DOLLARS AND _____ CENTS	\$	\$
50	671	TRAFFIC CONTROL	MO	1	_____ DOLLARS AND _____ CENTS	\$	\$
TOTAL ALTERNATE BID 3 PAVING ITEMS (FROM STA 28+00 TO PROJECT END)							
BID SUMMARY							
BASE BID TOTAL: _____ ALTERNATE BID 1 TOTAL: _____ ALTERNATE BID 2 TOTAL: _____ ALTERNATE BID 3 TOTAL: _____							

ADDENDUM #1 FOR PROJECTS INITIATED
AFTER MAY 1, 2016
REVISION 1

ITEM 220

LIME STABILIZED SUBGRADE

- 220.1 Description. Mix and compact lime, water and subgrade in the roadway.
- 220.2 Materials. Furnish uncontaminated lime of uniform quality that meets the requirements of the plans and specifications. Notify the Engineer in writing of the proposed lime source and of any proposed change in lime source. The Contractor shall obtain verification from the Engineer that the specification requirements are met before using the lime source. The Engineer may sample and test lime or lime/subgrade mixture at any time before compaction.
- A. Lime. Furnish lime that meets the requirements of TxDOT's DMS-6350 "Lime and Lime Slurry," and DMS-6330, "Lime Sources Prequalification of Hydrated Lime and Quicklime." Use hydrated lime slurry as shown on the plans.
 - B. Water. Furnish water free of industrial wastes and other objectionable material.
 - C. Asphalt. When permitted for curing purposes, furnish asphalt or emulsion in accordance with TxDOT's Item 300, "Asphalts, Oils, and Emulsions," as shown on the plans or as directed.
 - D. Mix Design. The Engineer shall determine the target lime content and optimum moisture content in accordance with ASTM D698 "Standard Test Methods for Laboratory Compaction Characteristics of Soil Using Standard Effort (12,400 ft-lbf/ft³ (600 kN-m/m³))" or based upon prior experience with the project materials. The Contractor may propose an alternative mix design developed in accordance with ASTM D698. The Engineer shall use ASTM D698 to verify the Contractor's proposed mix design before accepting it. The Contractor shall reimburse the County for any and all expenses incurred due to a request by the Contractor to change of mix designs or partial designs, material sources, etc. whether they are approved or not.
- 220.3 Equipment. Provide machinery, tools, and equipment necessary for proper execution of the work. Provide rollers in accordance with TxDOT's Item 210 "Rolling." Provide proof rollers in accordance with TxDOT's Item 216 "Proof Rolling" when directed.

- A. Slurry Equipment. Use slurry tanks equipped with agitation devices to slurry hydrated lime at the jobsite or any other approved location. The Engineer may approve other slurring methods. Provide a pump for agitating the slurry when the distributor truck is not equipped with an agitator. Equip the distributor truck with a sampling device in accordance with Tex-600-J, Part I, when using commercial lime slurry.
- B. Pulverization Equipment. Provide pulverization equipment that:
 - 1. cuts and pulverizes material uniformly to the proper depth with cutters that plane to a uniform surface over the entire width of the cut,
 - 2. shows a visible indication of the depth of cut at all times, and
 - 3. mixes the materials uniformly.

220.4

Construction. Construct each layer uniformly, free of loose or segregated areas, and with the required density and moisture content. Provide a smooth surface that conforms to the typical sections, lines, and grades shown on the plans or as directed.

- A. Preparation of Subgrade for Treatment. Shape the subgrade in accordance with Item 205 "Subgrade", and applicable bid items to conform to typical sections shown on the plans and as directed. The Contractor shall pulverize or scarify the existing raw subgrade sufficiently to allow penetration of the lime to the required depth.
- B. Pulverization. The Contractor shall pulverize or scarify the existing raw subgrade to allow penetration of the lime to the required depth.
- C. Application of Lime. Uniformly apply lime using slurry placement as shown on the plans or as directed. Add lime at the percentage determined in Section 220.2.D, "Mix Design" above. Apply lime only on an area where mixing can be completed during the same working day.

Start lime application only when the air temperature is at least 35°F and rising or is at least 40°F. The temperature shall be taken in the shade and away from artificial heat. Suspend application when the Engineer determines that weather conditions are unsuitable.

Slurry Placement. Provide slurry free of objectionable materials, at or above the approved minimum dry solids content, and with a uniform consistency that shall allow ease of handling and uniform

ADDENDUM #1 FOR PROJECTS INITIATED
AFTER MAY 1, 2016
REVISION 1

application. Deliver commercial lime slurry to the jobsite or prepare lime slurry at the jobsite, or other approved location, by using hydrated lime as specified.

Distribute slurry uniformly by making successive passes over a measured section of subgrade until the specified lime content is reached.

- D. **Mixing.** Begin mixing within 6 hours of application of lime. Hydrated lime exposed to the open air for 6 hours or more between application and mixing, or that experiences excessive loss due to washing or blowing, shall not be accepted for payment.

Thoroughly mix the subgrade and lime using approved equipment. Allow the mixture to mellow for 1 to 4 days, as directed. Sprinkle the treated materials during the mixing and mellowing operation, as directed, to achieve adequate hydration and proper moisture content. After mellowing, resume mixing until a homogeneous, friable treated subgrade is obtained.

After mixing, the Engineer shall sample the mixture at roadway moisture and test in accordance with Tex-101-E, Part III to determine compliance with the gradation requirements in Table 1.

TABLE 1

GRADATION REQUIREMENTS (MINIMUM % PASSING)

SIEVE SIZE	TREATED SUBGRADE
1-3/4 Inch	100
3/4 Inch	85
No.4	60

- E. **Compaction.** Compact the treated subgrade using density control. Multiple lifts are permitted when shown on the plans or approved. Bring each layer to the moisture content directed. When necessary, sprinkle the treated subgrade as directed. Determine the moisture content of the treated subgrade at the beginning and during compaction in accordance with ASTM D698.

Begin rolling longitudinally at the sides and proceed toward the center, overlapping on successive trips by at least one-half the width of the roller unit. Offset alternate trips of the roller. Operate rollers at a speed between 2 and 6 MPH, as directed.

Rework, recompact, and refinish treated subgrade that fails to meet or that loses required moisture, density, stability, or finish before the next layer is placed or the project is accepted. Continue work until specification requirements are met. Rework in accordance with Section 220.4.F, "Reworking a Section" below. Perform the work at no additional expense to the County.

The Testing Laboratory shall determine treated subgrade density of completed sections in accordance with ASTM D6938 "Standard Test Methods for In-Place Density and Water Content of Soil and Soil-Aggregate by Nuclear Methods (Shallow Depth)." The minimum level of testing shall consist of the following:

1. at least one test per station per lane of roadway.
2. a lane is defined as 12' wide section of pavement regardless of its use.

Compact to at least 95% of the maximum density as determined in accordance with ASTM D698, unless otherwise shown on the plans.

- F. Reworking a Section. When a section of lime treated subgrade is reworked within 72 hours after completion of compaction, rework the section to provide the required density. When a section is reworked more than 72 hours after completion of compaction, add additional lime at 25% of the percentage determined in Section 220.2.D, "Mix Design" at no additional cost to the County. Reworking includes loosening, adding lime or removing unacceptable treated subgrade if necessary, mixing as directed, compacting, and finishing. Determine a new maximum density of the reworked treated subgrade in accordance with ASTM D698, and compact to at least 95% of this density.
- G. Finishing. Immediately after completing compaction of the final layer of lime treated subgrade, clip, skin, or tight-blade the surface to a depth of approximately $\frac{1}{4}$ in. Remove the clipped material and dispose of it at an approved location. Roll the clipped surface immediately with a pneumatic tire roller until a smooth surface is attained. Add small amounts of water as needed during rolling. Shape and maintain the layer and surface in conformity with the typical sections, lines, and grades shown on the plans or as directed. The treated subgrade shall be finished within the tolerances required by TxDOT's Item 132.3.6.1, "Grade Tolerances."

- H. Curing. Cure for the minimum number of days shown in Table 2 by sprinkling as per TxDOT's Item 204 "Sprinkling", or by applying an asphalt material at a rate of 0.05 to 0.20 gal. per square yard as directed. Maintain moisture content during curing. Upon completion of curing, maintain the moisture content in accordance with TxDOT's Item 132.3.5, "Maintenance of Moisture and Reworking" for treated subgrade prior to placing subsequent courses. Do not allow equipment on the finished layer during curing except as required for sprinkling, unless otherwise approved. Apply seals or additional layers or surface course within 14 calendar days of final compaction.

TABLE 2

MINIMUM CURING REQUIREMENTS BEFORE PLACING
SUBSEQUENT LAYERS¹

ORIGINAL (UNTREATED) SUBGRADE PI	CURING (DAYS)
PI ≤ 35	2
PI > 35	5

1. Subject to the approval of the Engineer. Proof rolling may be required as an indicator of adequate curing.

220.5 Measurement.

- A. Lime. When lime is furnished in trucks, the weight of lime shall be determined on certified scales.

When lime is furnished in bags, indicate the manufacturer's certified weight. Bags varying more than 5% from that weight may be rejected. The average weight of bags in any shipment, as determined by weighing 10 bags taken at random, must be at least the manufacturer's certified weight.

Hydrated Lime slurry shall be measured as per Item 221 "Hydrated Lime and Lime Slurry".

- B. Lime Treatment. Lime treatment shall be measured by the square yard of surface area at the specified depth. The dimensions for determining the surface area are established by the widths shown on the plans and the lengths measured at placement.

220.6 Payment.

Lime Treatment. Lime treatment shall be paid for at the unit price bid for "Lime Treatment" by the square yard for the depth specified. This price is full compensation for shaping existing material, loosening, mixing, pulverizing, spreading, applying lime, compacting, finishing, curing, blading, shaping and maintaining, replacing, disposing of loosened materials, processing, hauling, preparing secondary subgrade, water, equipment, labor, tools, and incidentals.

Water for sprinkling. Sprinkling and rolling shall not be paid for directly, but shall be subsidiary to this Item, unless otherwise shown on the plans. Amendment of treated subgrade to correct soft spots shall be at the Contractor's expense.

Asphalt used solely for curing will not be paid for directly, but will be subsidiary to this Item. Asphalt placed for curing and priming will be paid for under Item 310, "Prime Coat/Sealer."

There are line code(s), description(s), and unit(s) for this Item.

NOTE: This Item requires other Standard Specifications

Item 130 "Borrow"
Item 205 "Subgrade"
Item 221 "Hydrated Lime and Lime Slurry"
Item 310 "Prime Coat/Sealer"

END OF ITEM 220

ADDENDUM #1 FOR PROJECTS INITIATED
AFTER MAY 1, 2016
REVISION 5

ITEM 221

HYDRATED LIME AND LIME SLURRY

221.1 Description. This Item shall govern for establishing the requirements for hydrated lime and commercial lime slurry of the type and grade considered suitable for use in the treatment of natural or processed materials or mixtures for subgrade, sub-base and base construction.

221.2 Materials. The various types and grades are defined and identified as follows:

- A. Type A. Hydrated Lime: Shall consist of a dry powder obtained by treating quicklime with enough water to satisfy its chemical affinity for water under the conditions of its hydration. This material is to consist essentially of calcium hydroxide or a mixture of calcium hydroxide and a small allowable percentage of calcium oxide, magnesium oxide and magnesium hydroxide.

When sampled and tested according to TxDOT's prescribed Tex-600-J procedures, hydrated lime shall conform to the requirements of TxDOT's DMS-6350. Hydrated Lime for stabilization purposes shall be applied, as provided in the governing specifications, as a dry powder or mixed with water to form a slurry at the jobsite.

- B. Type B. Commercial Lime Slurry: Shall be pumpable suspension of solids in water. The water or liquid portion of the slurry shall not contain dissolved material in sufficient quantity or nature that would be injurious for the purpose intended. The solids portion of the mixture, when considered on the basis of "solids content", shall consist principally of hydrated lime of a quality and fineness sufficient to meet TxDOT's DMS-6350.

221.3 Sampling and Testing. The sampling and testing of lime slurry shall be as determined by Test Procedure Tex-600-J, "Sampling and Testing Lime".

When Hydrated Lime is used, the quantity of lime will be measured by the ton of 2000 pounds, dry weight.

When Commercial Lime slurry is used, the quantity of lime shall be calculated from the required minimum percent solids based upon the use of Grade 1, Grade 2, or Grade 3 as follows:

Grade 1: The "Dry Solids Content" shall be at least 31 percent by weight of the slurry and the quantity of lime will be calculated by the ton of 2,000 pounds based on the 31 percent dry weight solids.

Grade 2: The "Dry Solids Content" shall be at least 35 percent by weight of the slurry and the quantity of lime will be calculated by the ton of 2,000 pounds based on the 35 percent dry weight solids.

Grade 3: The "Dry Solids Content" shall be at least 46 percent by weight of the slurry and the quantity of lime will be calculated by the ton of 2,000 pounds based on the 46 percent dry weight solids.

221.4

Measurement and Payment. Work performed and materials furnished as prescribed by this Item will be paid for at the unit price bid per ton of 2,000 pounds, dry weight for "Lime", of the type specified, which price shall be full compensation for supplying the lime, for all mixing, spreading, drying, application of the lime, water content of the slurry, for all manipulations required, for all hauling, and freight involved, for all tools, equipment, labor and for all incidentals necessary to satisfactorily complete the work.

There are line code(s), description(s), and unit(s) for this Item.

END OF ITEM 221

ADDENDUM #1 FOR PROJECTS INITIATED
AFTER MAY 1, 2014
REVISION 4

ITEM 252

IN-PLACE FULL DEPTH COLD FLEXIBLE PAVEMENT RECYCLING

252.1 Description. This Item shall govern for a stabilized base course composed of a mixture of the existing bituminous concrete pavement, the existing base course material, any required new material and an admixture. The manufacture of the stabilized base course shall be done by in-place pulverizing and blending of the existing pavement and base materials and the introduction of additives, if called for. Additives may be in the liquid or dry form.

252.2 Materials. The additive shall be of the type called for on the drawings or in the proposal.

Asphalt emulsions and cutback asphalts, when used, shall meet the requirements of the TxDOT "Standard Specifications for Construction and Maintenance of Highways, Streets, and Bridges" Item 300 "Asphalts, Oils and Emulsions", Latest Edition (hereinafter called simply "TxDOT Item 300").

Portland cement shall be in accordance with Item 222 "Portland Cement Stabilized Subgrade". Lime shall be in accordance with Item 221 "Hydrated Lime and Lime Slurry", or Item 224 "Quicklime (Stabilization)". Fly ash shall be in accordance with Item 223 "Lime-Fly Ash or Fly Ash Stabilized Subgrade".

Water shall meet the requirements of ASTM C94 "Standard Specification for Ready-Mixed Concrete".

When new materials are added, black base shall meet the requirements of Item 250 "Hot Mix Asphaltic Concrete Base Course (Black Base)" and granular materials shall meet the requirements of Item 230 "Crushed Aggregate Base Course".

252.3 Equipment. The Contractor shall furnish a self-propelled machine capable of pulverizing the existing materials to minimum depth of 10 inches, in one pass.

The equipment shall be of sufficient size, equipped with uniform blades and be capable of obtaining a uniform blend of existing and added materials. The equipment shall be capable of producing the gradation indicated herein, or additional screening and crushing will be required. The equipment must also be capable of mixing the pulverized material

and additive to a homogeneous mixture. The method of depositing the mixed material shall be such that segregation does not occur. The mixing equipment used shall be a Bomag MPH 100 Recycler, or equipment that is approved as equal.

When liquid additives are used, the mixing equipment shall be equipped with a positive displacement pump, capable of accurately metering the required quantity of liquid additive. The pump shall be equipped with a positive interlock system which will permit addition of the additive only when the pulverized material is present in the mixing chamber and will automatically shut off when the material is not in the mixing chamber. Each mixing machine shall be equipped with a meter capable of registering the rate of flow and total delivery of the liquid additive introduced into the mixture.

- 252.4 Application and Mixing of Liquid Additives. Liquid additives shall be uniformly distributed and mixed with the pulverized material and any existing underlying material, or new imported material, as specified. The machine used for injecting the liquid additive shall have a variable speed pump with a control system as specified above.

The mixing machine shall be equipped with a foot per minute instrument that is integral to the variable speed pump controller ensuring that additive can be added only when the machine is moving.

The totalizer shall be such that the amount of liquid used during any given period can be read directly. The application rate of the liquid additive shall be expressed in terms of gallons per square yard. This rate shall be based on the percent by weight of the total mixture, as determined by the Engineer.

- 252.5 Construction. When new base material is required, it shall be spread on the existing pavement section before the recycling process is begun. The type of equipment used, shall be capable of being adjusted so that an application rate, of the new material, of ± 5 percent is provided.

When exposed during the mixing process, the subgrade shall be firm and able to support, without displacement, the construction equipment used. Soft or yielding areas shall be corrected and made stable by scarifying and aeration, or the introduction of additives, and compacting until it is of uniform stability. The cost of repair of the subgrade is incidental to this item.

Where excessive surface deformation is evident, or when elevation or profile changes are required, pulverization should take place prior to the introduction of additives. Pulverization should also be the first step when

aeration is necessary, or when the moisture content must be increased or decreased.

The existing pavement, base material and new material shall be pulverized and blended so that the entire mass of material shall be uniformly graded.

A. Granular Base

The bituminous surface, any new material, except additive, and the existing granular base material shall be pulverized and mixed initially by the mixing equipment. If sufficient moisture is absent for proper mixing, water in the amount specified by the Engineer, shall be introduced using the mixing equipment. Graders may be used in the mixing operation, after the material has been given a preliminary pulverizing with the mixing equipment.

The mixing and aeration shall proceed from one side of the work area to the other (windrowed) using a motor grader, until the mixture has a uniform appearance, free from "flat" spots and excess moisture. Aeration of the mixture shall continue in this manner, until the mixture is dried to a moisture content acceptable to the Engineer.

After the mixture has been thoroughly mixed and aerated, it shall be spread and shaped with the grader. Spreading will be performed to provide a uniform layer of loose material. The pulverized material shall then be lightly compacted with a roller.

If required by the Engineer, the pulverized material and water shall be allowed to set-up for about 48 hours, or for the time directed by the Engineer. As part of the spreading operation, the mixture will be shaped so that when compacted, it will be in close conformity with the lines, grades, and cross-sections established by the Engineer.

After the curing period, the pulverized material shall be mixed with the kind and amount of additive indicated by the Engineer. The existing bituminous pavement, new material, if required, existing base material and additive shall be pulverized and blended until the new additive(s) is uniformly dispersed throughout the material. The introduction of the additive shall be done with the mixing equipment, as outlined above.

When tested in accordance with ASTM C136 "Standard Test Method for Sieve Analysis of Fine and Coarse Aggregates" the pulverized mixture shall meet the following gradation:

ADDENDUM #1 FOR PROJECTS INITIATED
AFTER MAY 1, 2014
REVISION 4

SIEVE SIZE CONFORMING TO ASTM E11	PERCENT RETAINED, BY WEIGHT
1 3/4 Inch	0
1 1/2 Inch	0 – 5
1 Inch	3 – 15
No. 40	60 – 90
No. 200	Greater than 95

Prior to the beginning of compaction, the mixture shall be in a loose condition for its full depth. The loose mixture shall then be uniformly compacted to the specified density, lines and grades.

Compaction shall begin immediately after final mixing. The mixture shall be compacted using vibratory rollers. After this initial compaction, final compaction and finishing shall take place with a smooth drum or pneumatic tired roller. The mixture shall be compacted to 95 percent of Standard Proctor Density (ASTM D698 "Standard Test Methods for Laboratory Compaction Characteristics of Soil Using Standard Effort (12,400 ft-lbf/ft³)") at \pm 2 percent of the optimum moisture content.

After the material is compacted, water shall be uniformly applied to the surface, as needed. The surface shall then be reshaped to the required lines, grades and cross-sections and then lightly scarified to loosen any imprint left by compacting and reshaping equipment.

The resulting surface shall be thoroughly rolled with a pneumatic tired roller and "skinned" by a power grader to achieve final grade, removing all loosened material from the surface. The surface shall then be compacted with the pneumatic roller, adding small increments of moisture, as needed, during rolling. If material larger than a No. 4 screen is present in the mixture, one complete coverage of the surface, with the flat wheel roller shall be made immediately after the skinning operation.

After the surface of the recycled base has been finished as specified herein, it shall be protected against rapid drying by applying an asphaltic membrane to the recycled surface immediately after its completion. The material for the asphaltic membrane shall be EAP&T (Emulsified Asphalt Prime and Tack), CSS-1, or SS-1 (Asphalt Emulsion), per TxDOT Item 300, as approved by the Engineer. The amount of asphaltic material (refer to plans) shall be sufficient to completely cover and seal the total

surface and fill all voids. The Contractor shall use this method for curing the recycled base and it shall be his responsibility to protect the asphalt membrane from being picked up by the traffic.

The asphalt membrane may remain in place when the proposed surface is placed. The surface course may be applied as soon after completion as operations will permit.

At the end of each day's construction, a straight transverse construction joint shall be formed by cutting back into the total width of completed work to form a true two inch depth vertical face free of loose and shattered material.

After the 3 day curing period, or as directed by the Engineer, completed sections may be opened immediately to local traffic and to construction equipment, during the curing period, provided the material has hardened sufficiently to prevent marring or distorting the surface by the equipment or traffic.

When a surface course is required, it shall be applied at the required thickness in accordance with Item 340 "Hot Mix-Hot Laid Asphaltic Concrete". Prior to placement of surface course, the recycled base shall be proof rolled to locate soft or yielding areas, the soft or yielding areas shall be corrected in accordance with Section 252.7 or as directed by the Engineer. Proof rolling equipment shall meet the requirements of TxDOT Standard Specifications for Construction and Maintenance of Highways, Streets, and Bridges" Item 216 "Proof Rolling", Latest Edition. A tack coat shall be applied in accordance with Item 340.11.

B. Black Base

When new black base is required, it shall be spread on the existing pavement section before the recycling process is begun, in accordance with Section 252.5.

When exposed during the mixing process, the subgrade shall be firm and able to support, without displacement, the construction equipment used. Soft or yielding subgrade shall be corrected in accordance with Section 252.5.

Pulverization shall take place prior to the introduction of additives. The existing pavement, base material and new material, except additives, shall be pulverized and blended so that the entire mass of material will be uniformly graded.

ADDENDUM #1 FOR PROJECTS INITIATED
AFTER MAY 1, 2014
REVISION 4

The bituminous surface and black base shall be mixed initially by the pulverizing equipment. If excess moisture is present, the material shall be worked until it is at the moisture content specified by the Engineer. Graders may be used in the mixing operation after the material has been given a preliminary mixing with the pulverizing machine.

The mixing and aeration shall proceed from one side of the work area to the other (windrowed) until the mixture has a uniform appearance, free from "fat" spots and excess moisture. Aeration of the mixture shall continue in this manner until the mixture is dried to a moisture content acceptable to the Engineer.

After the mixture has been thoroughly mixed and aerated, it shall be spread and shaped with a grader. Spreading will be performed to provide a uniform layer of loose material.

After spreading, the pulverized material shall be mixed with the kind and amount of additive indicated by the Engineer. The existing bituminous pavement, new material if required, existing base material and additive, probably an emulsion, shall be blended until the new additive(s) is uniformly dispersed throughout the material. The introduction of the additive shall be done with the mixing equipment.

When tested in accordance with ASTM C136 "Standard Test Method for Sieve Analysis of Fine and Coarse Aggregates", the pulverized material shall meet the following gradation:

SIEVE SIZE CONFORMING TO ASTM E11	% RETAINED, BY WEIGHT
1-3/4 Inch	0
1-1/2 Inch	0 – 5
1 Inch	3 – 15
No. 40	60 – 90
No. 200	Greater than 95

After the introduction of the additive(s), and the mixture has been thoroughly mixed and aerated, it shall be spread with a grader and any excess moisture, from the emulsion, shall be removed. If required, aeration of the mixture shall continue until the mixture is dried to a moisture content acceptable to the Engineer.

ADDENDUM #1 FOR PROJECTS INITIATED
AFTER MAY 1, 2014
REVISION 4

After the mixture has been thoroughly mixed and aerated, it shall be spread and shaped with a grader. Spreading will be performed to provide a uniform layer of loose material. The pulverized material shall be lightly compacted with a roller and then allowed to set-up for about 48 hours, or for the time directed by the Engineer.

After the curing period, the pulverized material shall be re-mixed with the mixing equipment.

Prior to the beginning of compaction, the mixture shall be in a loose condition to its full depth. The loose mixture shall then be uniformly compacted to the specified density, lines and grades.

Compaction shall begin immediately after final mixing. The mixture shall be compacted in one lift using vibratory rollers. After initial compaction, final compaction and finishing shall take place with a smooth drum or pneumatic tired roller. The mixture shall be compacted to 95 percent of Standard Proctor Density (ASTM D698).

After the material is compacted, a tack coat, if required, shall be applied in accordance with Item 340.11.

Where a surface course is required, it shall be applied at the required thickness in accordance with Item 340 "Hot Mix-Hot Laid Asphaltic Concrete".

At the end of each day's construction, a straight transverse construction joint shall be formed by cutting back into the total width of completed work to form a true two inch depth vertical face, free of loose and shattered material.

252.6 Traffic. After the curing period, or as directed by the Engineer, completed sections of recycled base may be opened immediately to local traffic and to all traffic, provided it has hardened sufficiently to prevent marring or distorting of the surface by equipment or traffic.

252.7 Maintenance. The Contractor shall be required, within the limits of his contract, to maintain the recycled base course in good condition until all work has been completed and accepted. Maintenance shall include immediate repairs to any defects that may occur. This work shall be done by the Contractor at his own expense and may be repeated as often as may be necessary to keep the area continuously intact. Faulty work shall be replaced for the full depth of treatment. It is the intent of this Item that the Contractor constructs the plan depth of recycled base in one

homogeneous mass. The addition of thin layers in order to provide the minimum specified depth will not be permitted.

- 252.8 Quality Assurance. The Testing Laboratory's representative will determine the in-place density in accordance with ASTM D6938 "Standard Test Method for In-Place Density and Water Content of Soil and Soil-Aggregate by Nuclear Methods" and D 1556, "Standard Test Methods for Density and Unit Weight of Soil in Place by Sand-Cone Method". The minimum level of testing will consist of at least two tests using the nuclear density gauge and one test using the Sand Cone Method, for each 1,000 feet per lane of roadway or 4,000 square feet of base material.
- 252.9 Measurement. Cold in-place recycling shall be measured by the square yard. The additive of the type specified by the Engineer shall be measured by the ton or gallon.
- 252.10 Payment. The basis of payment for Full Depth Cold Flexible Pavement Recycling shall be by the unit price bid per square yard, which price shall be full compensation for all cutting back shoulders, stripping and scarifying, if necessary, pulverizing and blending, the addition of any admixture, remixing, compaction and curing, including the removal and disposal of all excess material, including all labor, tools and equipment necessary to do the work.

Liquid additives shall be paid for by the unit price bid per gallon for the material. Dry additives shall be paid for by the unit price bid, per ton, for the material. Asphalt membrane shall be paid for by the unit price bid per gallon, per Item 310 "Prime Coat" and Item 323 "Emulsified Asphalt Treatment".

When it is necessary to add additional materials, granular materials shall be paid for under Item 230 "Crushed Aggregate Base Course" and "Black Base" shall be paid for under Item 250 "Hot Mix Asphaltic Concrete Base Course (Black Base)".

The surface course, including any necessary tack, shall be paid for under Item 340 "Hot Mix-Hot Laid Asphaltic Concrete".

There are line code(s), description(s), and unit(s) for this Item.

NOTE: This Item requires other Standard Specifications

Item 221 "Hydrated Lime and Lime Slurry"
Item 222 "Portland Cement Stabilized Subgrade"
Item 223 "Lime Fly Ash or Fly Ash Stabilized Subgrade"

- Item 224 "Quicklime (Stabilization)"
- Item 230 "Crushed Aggregate Base Course"
- Item 250 "Hot Mix Asphaltic Concrete Base Course (Black Base)"
- Item 310 "Prime Coat/Sealer"
- Item 340 "Hot Mix-Hot Laid Asphaltic Concrete"

END OF ITEM 252

ADDENDUM #1 FOR PROJECTS INITIATED
AFTER SEPTEMBER 1, 2017
REVISION 18

ITEM 360

CONCRETE PAVEMENT

360.1 Description. This Item shall govern for a pavement of portland cement concrete with reinforcement. The pavement shall be as shown on the drawings, and may or may not include monolithic curbs. The pavement includes any driveways that are included in the project bid.

The pavement shall be constructed as herein specified on the prepared subgrade or other base course in conformity with the thickness and typical cross-sections shown on the drawings, and to the lines and grades established by the Engineer. All materials shall be provided from an approved Texas Department of Transportation (TxDOT) supplier and it shall be the responsibility of the Contractor to provide certification that such approval has been met. In addition, other tests or approvals may be required at the discretion of the Engineer.

360.2 Materials. Harris County's standard mix design shall contain minimum 5-1/2 sacks (94 pounds per sack) of cementitious material (including fly ash as necessary) per cubic yard and achieve a minimum compressive strength of 3,000 psi at 28 days.

The use of fly ash is acceptable and when used, the mix design shall contain 5-1/2 sacks of cementitious material per cubic yard with a fly ash content of not more than 25 percent by weight, and will achieve a minimum compressive strength of 3,000 psi at 28 days. It is recommended that the percent of fly ash by weight be reduced to a maximum of 20 percent during cold weather concreting (average ambient temperature, over a 24 hour period after placement, less than 50° F). Fly ash shall be Class C or Class F, conforming to the requirements of ASTM C618 "Standard Specification for Coal Fly Ash and Raw or Calcined Natural Pozzolan for Use in Concrete." Fly ash shall have a minimum combined Oxide content of 50 percent for Class C or 70 percent for Class F. Do not use Class C fly ash in sulfate-resistant (Type II cement) concrete.

"High Early Strength Concrete" shall contain 7 sacks of portland cement (only) per cubic yard and may be produced from either Type I, Type II, or Type III portland cement with other chemical admixtures.

Concrete Components:

Concrete shall be composed of portland cement, fly ash (if required), water, chemical admixtures and coarse and fine aggregates, as outlined below:

- A. Portland cement shall meet the requirements of ASTM C150 "Standard Specification for Portland Cement." Unless otherwise permitted or required, cement shall be Type I, Type II, or Type III.
- B. Fly Ash for concrete pavement (if applicable) shall meet the requirements of TxDOT's DMS-4610, "Fly Ash." Fly ash is not allowed for use in High Early Strength Concrete.
- C. Mixing water for concrete shall conform to the requirements of ASTM C1602 "Standard Specification for Mixing Water Used in the Production of Hydraulic Cement Concrete."
- D. Chemical admixtures shall conform to the following specifications:
 - 1. Air-entraining admixtures shall conform to the requirements of ASTM C260 "Standard Specification for Air-Entraining Admixtures for Concrete"
 - 2. Chemical admixtures shall conform to the requirements of ASTM C494 "Standard Specification for Chemical Admixtures for Concrete."
- E. Aggregates shall conform to ASTM C33 "Standard Specification for Concrete Aggregates."

Coarse aggregate shall consist of durable particles of gravel, crushed stone, or combinations thereof, free from frozen material or injurious amounts of salt, alkali, vegetative matter, or other objectionable material either free or as an adherent coating, and its quality shall be reasonably uniform throughout. It shall contain no more than 0.25 percent by weight of clay lumps and not more than 1.0 percent by weight of laminated and/or friable particles. When tested by ASTM C136 "Standard Test Method for Sieve Analysis of Fine and Coarse Aggregates" and C117 "Standard Test Method for Minerals Finer than 75- μ m (No. 200) Sieve in Mineral Aggregates by Washing", it shall meet the following grading requirements:

TABLE 1

COARSE AGGREGATE GRADATION

SIEVE SIZE	% RETAINED, BY WEIGHT
1-3/4 Inch	0
1-1/2 Inch	0 – 5

ADDENDUM #1 FOR PROJECTS INITIATED
AFTER SEPTEMBER 1, 2017
REVISION 18

SIEVE SIZE	% RETAINED, BY WEIGHT
3/4 Inch	30 – 65
3/8 Inch	70 – 90
No. 4	95 – 100

The loss by decantation shall be a maximum of 1 percent

- F. Fine aggregate shall consist of clean, hard, durable and uncoated particles of natural or manufactured sand or a combination thereof, with or without mineral filler. It shall be free from frozen material, or injurious amounts of salt, alkali, vegetative matter or other objectionable material and it shall not contain more than 0.5 percent, by weight, of clay lumps. When subjected to the color test for organic impurities, ASTM C40 “Standard Test Method for Organic Impurities in Fine Aggregates for Concrete”, the fine aggregate shall show a color not darker than the standard.

Unless otherwise specified, fine aggregate shall meet the following grading requirements:

TABLE 2

FINE AGGREGATE GRADATION

SIEVE SIZE	% RETAINED BY WEIGHT
3/8 Inch	0
No. 4	0 – 5
No. 8	0 – 20
No. 16	15 – 50
No. 30	35 – 75
No. 50	65 – 90
No. 100	90 – 100
No. 200	97 – 100

Fine aggregate shall be subjected to ASTM D2419 “Standard Test Method for Sand Equivalent Value of Soils and Fine Aggregate”. The sand equivalent shall be not less than 80.

Mineral filler shall consist of stone dust, clean crushed sand or other approved inert material.

Reinforcing Steel:

Unless otherwise designated on the drawings, or herein, all bar reinforcement shall be deformed and shall conform to ASTM A615 "Standard Specification for Deformed and Plain Carbon-Steel Bars for Concrete Reinforcement", Grade 60, open hearth, basic oxygen or electric furnace new billet steel. The use of Grade 40 is permissible for bars that must be bent. The use of prefabricated deformed steel bar mats, conforming to ASTM A184 "Standard Specification for Welded Deformed Steel Bar Mats for Concrete Reinforcement", is not permitted.

Tie bars (including L-bars) shall be the same spacing and diameter as the transverse or longitudinal bars (as the case may be), and shall be tied to the transverse or longitudinal reinforcing steel being used in the pavement. Tie bars shall be a minimum of 30 inches in length. Type III adhesives meeting the requirements of TxDOT Material Specification DMS-6100 "Epoxy and Adhesives" shall be used for installing drilled-in reinforcing steel and dowels, into the existing concrete pavements.

Expansion Joints:

Boards for expansion joint filler shall be 3/4 inch finished thickness. The material for the boards shall consist of "All Heart Merchantable Redwood" or composite material as approved by the Engineer. The joint filler shall meet the testing requirements of ASTM D545 "Standard Test Methods for Preformed Expansion Joint Fillers for Concrete Construction (Non-extruding and Resilient Types)."

If the joint filler used is a bituminous composite, it shall meet the requirements of ASTM D1751 "Standard Specification for Preformed Expansion Joint Filler for Concrete Paving and Structural Construction (Non-extruding and Resilient Bituminous Types)."

Joint sealant shall meet the requirements of ASTM D6690 "Standard Specification for Joint and Crack Sealants, Hot Applied, for Concrete and Asphalt Pavements", Type II or III. Joint sealant for expansion joints shall be installed 1/4 inch below the top of pavement elevation. Prefabricated expansion joints may be used with approval by the Engineer.

Load transmission devices shall consist of an 18 inch smooth dowel placed as shown on the Standard Civil Drawing. The dowel size varies with pavement thickness as shown on the Concrete Pavement Details of the Harris County Standard Civil Drawings. Dowels may be sheared or saw cut to the desired length.

360.3

Storage of Materials. Cement shall be stored in well ventilated weathertight buildings, bins, or silos which shall exclude moisture and contaminants.

Aggregate stockpiles shall be arranged and used in such a manner as to avoid contamination, with other materials or with other sizes of like aggregates. To ensure that this condition is met, any test for determining conformance to requirements for cleanliness and grading shall be performed on samples secured in accordance with ASTM D75 "Standard Practice for Sampling Aggregates." Frozen or partially frozen aggregates shall not be used. Unless otherwise authorized by the Engineer, all aggregate shall be stockpiled at least 24 hours prior to use, to reduce free moisture content.

Chemical admixtures shall be stored in such a manner as to avoid contamination, evaporation, or damage. For those used in the form of suspensions or non-stable solutions, agitating equipment shall be provided to assure thorough distribution of the ingredients. Liquid admixtures shall be protected from freezing and from temperature changes which would adversely affect their characteristics.

- 360.4 Proportioning of Concrete. Concrete for all parts of the work shall be of the specified quality, capable of being placed without excessive segregation and, when hardened, shall develop all characteristics required by this Item and the contract documents.

The specified compressive strength of the concrete, for each portion of the structure, shall be as designated in the contract documents. Strength requirements shall be based on the 28 day and 7 day compressive strength, respectively.

- 360.5 Concrete Classification. Concrete shall be classified as shown in Table 3 of Item 421 "Structural Concrete".

- 360.6 Selection of Proportions. Proportions of materials for concrete shall be established to provide:

- A. Workability and consistency to permit concrete to be worked readily into forms and around reinforcement under conditions of placement to be employed without segregation or excessive bleeding.
- B. Strength requirements in accordance with Table 3 of Item 421.
- C. Resistance to special exposure as required by the Engineer and as specified in the contract documents or in Special Provisions.

Unless otherwise permitted, the concrete mix design shall be proportioned to provide a slump between 1 and 6 inches. A slump range of 1 to 3-1/2 inches shall be used for concrete placed with a slip form paver, while

vibrated concrete shall have a slump range of 2-1/2 to 6 inches, when tested in accordance with ASTM C143 "Standard Test Method for Slump of Hydraulic-Cement Concrete." A slump test will be made for each sample of concrete obtained, or when slumps appear to be outside specification requirements. The allowable air content for moderate exposure is:

AGGREGATE SIZE	% AIR CONTENT
1-1/2 Inch	2.5 - 4.5
3/4 Inch	3.5 - 5.0

The Engineer may reject any concrete shown to be outside of these requirements.

All concrete pavement shall have a minimum design compressive strength of 3,000 psi at 28 days. A minimum of 4 test cylinders shall be made for each 150 cubic yards, or portion thereof, placed each day. Samples shall be taken in accordance with ASTM C172 "Standard Practice for Sampling Freshly Mixed Concrete" and molded and cured in accordance with ASTM C31 "Standard Practice for Making and Curing Concrete Test Specimens in the Field."

All test specimens shall be prepared in accordance with ASTM C617 "Standard Practice for Capping Cylindrical Concrete Specimens" and tested in accordance with ASTM C39 "Standard Test Method for Compressive Strength of Cylindrical Concrete Specimens." Two specimens shall be tested at 7 days and two specimens shall be tested at 28 days. The acceptance test results shall be the average of the two specimens tested for each age interval. If one specimen in a test age indicates evidence of improper sampling, handling, molding or testing, it shall be discarded and the strength of the remaining specimen shall be considered the test result. Should both specimens in a test interval show any of the aforementioned defects, the Engineer may request that cores be taken in the affected area.

Additional test specimens may be required due to concrete placing conditions and due to use of high early strength concrete. No extra compensation shall be allowed for materials and work involved in fulfilling these requirements.

360.7 Equipment. All equipment necessary for the construction of concrete pavement shall be on the job and shall have been approved by the Engineer as to condition, before the Contractor will be permitted to begin construction operations on which the equipment is to be used.

Side forms shall be of metal of approved cross-section. The preferred depth of the form shall be equal to the required edge thickness of the pavement. Forms with depths less than the required edge thickness of the pavement will be permitted, provided the difference between the form depth and the edge thickness is not greater than 1 inch, and further provided that forms of a depth, less than the pavement edge are brought to the required edge thickness by securely attaching wood or metal strips, of approved section, to the bottom of the form, or by grouting under the form.

The length of form sections shall be not less than 10 feet and each section shall provide for staking in position with not less than 3 pins. Flexible or curved forms of wood or metal of proper radius shall be used for curves of 100 foot radius or less. Forms shall be of ample strength and shall be provided with adequate devices for secure setting so that when in-place they will withstand without visible springing or settlement, the impact and vibration of the finishing machine. The forms shall be free from warp, bends or kinks and shall be sufficiently true to provide a reasonably straight edge on the concrete. The top of each form section, when tested with a straight edge, shall conform to the requirements specified for the surface of the completed pavement. Sufficient forms shall be provided for satisfactory prosecution of the work.

A minimum of two hand vibrators is required at the jobsite when placing concrete. A hand vibrator shall be used around all load transfer devices and intersections where screeds or slip form pavers cannot be operated.

Pavement shall be finished by machine, except as hereinafter provided. Placement shall be the Contractor's responsibility and shall be based upon equipment sequences utilized in accordance with the recommendations and practices of ACI 304R "Guide for Measuring, Mixing, Transporting, and Placing Concrete", and with the approval of the Engineer.

The Contractor shall furnish and maintain at least two standard 10 foot steel or aluminum straight edges.

Where applicable, the Contractor shall furnish a sufficient number of bridges equipped to ride on the forms and span the pavement for finishing operations and for the installation and finishing of joints and center strips. All necessary finishing and edging tools shall be furnished as may be required to complete the pavement in accordance with the drawings.

360.8 Slip Form Paver. Slip form pavers are allowed by Harris County.

360.9 Subgrade and Forms. The subgrade shall be prepared as required by the applicable subgrade specification items. Rolling and sprinkling shall be performed as necessary, or as directed. The roadbed shall be completed to the elevation as required on the typical sections shown on construction drawings. Drainage of the roadbed shall be maintained at all times.

The subgrade shall be finished to the exact section of the bottom of the pavement as shown on plans. The subgrade shall be maintained in a smooth, compacted condition, in conformity with the required section and established grade until the pavement is placed, and shall be kept thoroughly wetted down sufficiently in advance of placing any pavement to insure its being in a firm and moist condition for at least 2 inches below the prepared surface. No equipment or hauling shall be permitted on the prepared subgrade, except on special permission of the Engineer, which will be granted only in exceptional cases and only where a suitable protection in the form of two-ply timber mats or other approved material is provided.

The subgrade under the forms shall be firm and cut true to grade so that each form section when placed will be firmly in contact for its whole length and base width, and exactly at the established grade. Any subgrade under the forms below established grade shall be corrected, using suitable material, placed, sprinkled and rolled as directed. Forms shall be staked with at least 3 pins for each 10 foot section. A pin shall be placed at each side of every joint. Form sections shall be tightly joined and keyed to prevent relative displacement. Forms shall be cleaned and oiled each time they are used.

Sufficient subgrade shall be prepared far enough in advance of concrete placement to allow a minimum of 300 feet of forms to be set in place in advance of concrete placement at all times (with exception of intersections, etc.) or as approved by the Engineer. Conformity of the grade and alignment of forms shall be checked immediately prior to placing concrete and all necessary corrections made by the Contractor. Where any form has been disturbed or any subgrade has become unstable, the form shall be reset and rechecked. In exceptional cases, the Engineer may require suitable stakes driven to the grade of the bottom of the forms to afford additional support. Sufficient stability of forms to support the equipment operated thereon and to withstand its vibration without springing or settlement shall be required. If forms settle over 1/8 inch under finishing operation, paving operations shall be stopped and the forms shall be reset to line and grade.

Forms shall remain in place for a minimum of 8 hours after the concrete has been placed. They shall be carefully removed so that there is little or no damage done to the edge of the pavement. Any damage resulting

from this operation shall be immediately repaired. After the forms have been removed, the ends of all joints shall be cleaned, and any honeycombed areas pointed up with an approved mortar.

Immediately after pointing is complete, the form trench shall be filled with earth from the shoulders in such manner as to shed water from rainfall or curing away from the edge of the pavement. On completion of the required curing, the subgrade or shoulders adjacent to the pavement shall be placed in condition to maintain drainage.

360.10 Reinforcing Steel and Joint Assemblies. All reinforcing steel, tie bars, load transmission units and splices used in accordance with plan provisions meeting the requirements of Item 440 "Reinforcing Steel", shall be accurately placed and secured in position in accordance with the details shown on drawings.

Reinforcing bars shall be secured at all splices and at alternating intersections. The tie bars shall be installed in required position by the method and device shown on drawings, or by approved method and device equivalent thereto. Bar coatings required by plans, and of material specified, shall be completed and the bars and coating shall be free of rust, dirt or other foreign matter at the time of installation in the concrete. Reinforcing bars shall be supported on bar chairs or other approved devices placed on maximum 36 inches center each way, and placed so that the reinforcing bar is located at the centerline of the concrete.

Where plans require an assembly of parts at pavement joints, the assembly shall be completed, placed at required location and elevation, and all parts rigidly secured in required position as shown on plans, or by approved method and devices equivalent thereto. Dowel bars shall be accurately installed in joint assemblies in accordance with drawings, each parallel to the pavement, and shall be rigidly secured in required position by such means (as shown on plans, or approved equivalent thereto) that will prevent displacement of the dowels during placing and finishing of the concrete. The assembled units comprising the load transmission devices shall be accurately installed in joint assemblies in accordance with plans. Each unit shall be vertical with its length perpendicular to the centerline of the pavement, and all units shall be rigidly secured in required position by such means (as shown on drawings, or approved equivalent thereof) that will prevent displacement of the expansion joint during placing and finishing of the concrete. Joint filler shall be accurately notched to receive each load transmission unit. All load transmission units shall be free of rust and clean when installed in the concrete.

360.11 Concrete Placing. Except by specific written authorization of the Engineer, concrete shall not be placed when the ambient temperature is

below 40°F and falling. Concrete may be placed when the ambient temperature is above 35°F and rising, the ambient temperature being taken in the shade and away from artificial heat.

The Contractor shall have available a sufficient supply of approved cotton mats, polyethylene sheeting or other approved covering materials to immediately protect concrete if the air temperature falls to 32°F, or below, if the concrete has been in place for less than 4 hours. Such protection shall remain in place during the period the temperature continues 32°F or below, or for a period of not more than 5 days. Neither salt nor other chemical admixtures shall be added to the concrete to prevent freezing. The Contractor shall be responsible for the quality and strength of concrete under cold weather conditions and any concrete damaged by freezing shall be removed and replaced at the Contractor's expense.

When the concrete reaches a temperature of 85°F, retarders shall be introduced into the mixture.

If the concrete temperature continues to rise and reaches 95°F, a plasticizer shall be introduced into the mixture. Above 95°F, ice may be used to control temperature, in lieu of a plasticizer.

For concrete between temperatures of 85°F through 95°F, the slump shall be as specified in this Item. For concrete with temperatures between 95-100°F, slumps shall be as specified by the Engineer. The temperature of the concrete shall at no time exceed 100°F. Once concrete has reached a temperature above 100°F, it shall be rejected.

The amount of retarder or plasticizer, introduced into a mixture, shall be in accordance with the manufacturer's recommendations. See Section 360.2, Materials, for requirements of admixtures.

No concrete shall be used if:

- A. the concrete has developed initial set, or
- B. the concrete has not been placed within 1-1/2 hours after the initial water has been added.

Pouring concrete during inclement weather, which would adversely affect the quality and/or finish of the concrete pavement does not relieve the Contractor of his responsibility to provide a pavement that complies with the Item.

360.12 Joints. All transverse and longitudinal joints in the pavement shall be at the locations and of the type shown on the drawings.

Expansion Joints:

Transverse expansion joints shall be formed perpendicular to the centerline and surface of the pavement, and shall be constructed in accordance with the drawings.

The seal space shall be created by either of the following methods:

- A. Seal Space Form (aka Rip Strip) After the transverse finishing machine and before the longitudinal finishing machine has passed over the joint, the Contractor shall test the joint assembly for correctness of position and make any required adjustment in position of the joint assembly. After removal of the seal space form, the seal space above the joint assembly shall be thoroughly cleaned and the concrete faces of the seal space shall be left true to line and section throughout the entire length of the joint.
- B. Other method as approved by the Engineer.

On completion of curing of the pavement, the expansion joint sealant of the type specified shall be placed in accordance with drawings. The faces of the seal space shall be washed and cleaned and surface-dry at the time sealant is placed. On completion of sealing, the pavement surface (adjacent to the joint) shall be left free of sealing material.

Sawcut Joints: - Transverse Contraction and Longitudinal

All contraction joints (transverse or longitudinal) that are not at the edge or end of a pour shall be saw cut. Metal or fiber "rip" strips placed in the uncured concrete will not be permitted. Where sawed joints are required, they shall be sawed as soon as sawing can be accomplished, without damage to the pavement, and as directed by the Engineer. Once sawing has commenced, it shall be continued until completed. The saw cut shall be made with one pass of the concrete saw. Sawing must be accomplished even in rain or cold weather. All sawing must be completed within 24 hours of the concrete pavement placement. Within 24 hours of completing the concrete pour, all sawcut joints shall be sawed and washed of all residue. Should the sawing for any day's placement fail to be completed within 48 hours; the following concrete placement shall be limited to the amount that was sawed on time. The limitation shall continue until the sawing crew demonstrates it can handle a larger volume of sawing.

The sawed cut shall be a minimum of 1/4 inch width and have a depth of one-fourth the thickness of the pavement. After sawcutting, the joint shall

be sealed with joint sealer, in accordance with the instructions supplied by the manufacturer of the joint sealant. Sealant shall fill the joint from bottom to 1/4 inch below concrete surface. Use of backer rods in sawcut joints is prohibited.

Unless otherwise specified, transverse sawed control joints shall be constructed at 20 foot intervals measured along the centerline of the pavement section, or as directed by the Engineer.

Longitudinal Construction Joints:

When constructing a longitudinal construction joint, all applicable provisions of Section 360.7 shall apply in addition to the following requirements:

The face of the bulkhead at the joint shall be grooved or recessed as necessary to provide the required spaces for the top and bottom breaker strips as shown on plans. The bulkhead shall be either drilled or notched to receive the tie bars. Tie bars shall be secured in required position by use of adequate transverse bracing and vertical supports meeting the approval of the Engineer.

360.13 Terminating Concrete Placement:

Normal Terminating Procedures. Concrete placement shall be terminated at an expansion joint or a transverse construction joint that is coincidental with a location of a proposed contraction joint.

When the concrete placement is terminated at an expansion joint or a transverse construction joint, the complete joint assembly shall be installed and rigidly secured in the required position as shown on the plans.

A bulkhead of sufficient cross-sectional area to:

- A. prevent deflection and
- B. accommodate the dowels

shall be provided. The bulkhead shall be shaped accurately to the cross-section of the pavement and installed as a back-up for the expansion joint header or transverse construction joint header and rigidly secured in the required position to permit accurate finishing of the concrete up to the joint.

After the concrete has been finished to the joint, formation of the joint seal space and finishing of the joint shall be executed as specified herein and in accordance with plan requirements. The back-up bulkhead shall remain in place until immediately prior to the time when concrete placement is resumed. It shall then be carefully removed in such manner that no element of the joint assembly will be disturbed. The exposed portions of the joint assembly shall be free of adherent concrete, dirt or other material.

Unscheduled Terminating Procedures. When concrete placement must be terminated at a location other than an expansion joint or transverse construction joint, all applicable provisions of Section 360.7 shall apply, in addition to the following requirements:

A bulkhead shall be installed as a vertical form to pour the concrete against. The bulkhead adjoining the pavement end shall consist of upper and lower panels, with a gap of approximately two inches between, through which the reinforcing steel mat extends. During the concrete pouring process, some concrete will extrude through the gap, which is to be left in place to create a roughly formed "keyway" into the subsequent pour section.

Concrete shall be placed and finished to this bulkhead. Any concrete that falls onto the subgrade ahead of the bulkhead shall be removed and disposed of as directed. The seam created by a construction joint of this type shall have a saw-cut seal space and shall be sealed as required for construction joints.

360.14 Finishing. All finishing shall be in accordance with ACI 325.6R "Texturing Concrete Pavements".

The Engineer shall approve the straightedge. The surface of the concrete shall not vary from the straightedge by more than 1/16 inch per foot from the nearest point of contact, and in no case shall the maximum deviation from a ten foot straightedge to the pavement be greater than 1/8 inch. Any high spots causing a departure from the straightedge in excess of that specified shall be ground down by the Contractor to meet the surface test requirements, when required by the Engineer.

360.15 Curing. The Contractor shall prevent surface drying of the pavement before application of curing system by means that may include water fogging, use of wind screens or the use of evaporation retardants. He shall provide for protection of freshly laid concrete against pitting and washing from rain, by placement of canvas and/or waterproof covering material to protect all placed concrete. The covering material is required to be on the jobsite at the time and place of pouring.

The curing system may be:

- A. Liquid Membrane. Liquid membrane curing shall be used as per Item 526 "Membrane Curing".
- B. Additional Curing Methods. Other methods meeting the requirements of ACI 308R "Standard Practice for Curing Concrete" must be submitted by the Contractor in writing prior to concrete placement and approved by the Engineer.

360.16 Protection of Pavement and Opening to Traffic. The Contractor shall erect and maintain the barricades required by the plans, and such other barricades and approved devices necessary to exclude public traffic and traffic of his employees and agents from the newly placed pavement for the periods of time hereinafter prescribed. Portions of the roadway, or crossings of the roadbed required to be maintained open for use by traffic, shall not be obstructed by the above required barricades. Crossings of the pavement required by plans, or by construction sequence, during the period prior to opening to traffic as herein specified, shall be provided with an adequate and substantial bridge, approved by the Engineer.

Cracked pavement shall be cored by Harris County any time after the 28 day cure time is complete. The location of these cores shall be selected by the Engineer. Pavement that has developed full depth cracks (greater than $t/4$ inch depth, where t = thickness of pavement) may, at the County's option, be left in place and repaired by the epoxy injection method. Otherwise the cracked pavement shall be removed and replaced. There shall be no additional payment for repairs or replacement. Basis of removal for cracked pavement shall be determined by the engineer and the extent of this pavement removal shall be based on the crack pattern and number of cracks in each panel. If the cracks are wide spread (vertically or horizontally) or close to expansion joint or control joint, and over a large area of 12 foot wide panel, then entire panel shall be removed and replaced as determined by the Engineer.

Surface cracks $t/4$ inches and less in depth may be repaired by the epoxy injection method at no cost to the County.

Prior to epoxy injection, the Contractor shall submit to the County for approval, the injection method to be used. The Contractor shall furnish a minimum of 2 year warranty when utilizing the epoxy injection method.

New pavement sections shall be closed to all traffic, both PUBLIC and CONSTRUCTION, until the concrete has attained a compressive strength of 2,700 psi. If the Contractor or the County desires to open the new

pavement section to traffic early, an additional set of test cylinders must be requested for an early test. If the early test indicates that the minimum compressive strength requirement has been met, and if all other requirements of this Item have been met, the pavement section can be opened to traffic. If the Contractor requests the early test, the Contractor will pay the cost. If the County requests the early test, the County will pay the cost. Such opening of a new pavement section, to PUBLIC or CONSTRUCTION traffic, shall in no manner relieve the Contractor from his responsibility of the work.

On those sections of pavement to be opened to PUBLIC traffic, the pavement shall be thoroughly cleaned, stable material shall be placed, graded, and compacted against the pavement edge or curb unless otherwise specified. Joints shall be sealed and cured, and all required traffic control work shall be performed for the safety of the traffic.

The Engineer may require the opening of pavement to traffic prior to the minimum strength specified above under conditions of emergency, which in his opinion, require such action in the interest of the public. In no case shall the Engineer order opening of the pavement to traffic within less than 72 hours after the last concrete in the sections is placed unless an approved high early strength concrete was used. The Contractor shall remove any curing mats, place earth against the pavement edges, and perform other work involved in providing for the safety of traffic as required by the Engineer in ordering emergency opening. Orders for emergency opening of the pavement to traffic will be issued by the Engineer in writing.

360.17 Backfilling Behind Curbs and in Medians and Directional Islands. The Contractor is required to backfill behind all curbs and within medians and directional islands, after completion of the paving operation. The backfill material shall be on-site material having the prior approval of the Engineer. No separate payment shall be made for backfilling behind curbs and in medians and directional islands, but it shall be considered incidental to this Item.

360.18 Deficient Pavement Thickness. It is the intent of this Item that the pavement be constructed in strict conformity with the thickness and typical sections shown on plans.

Concrete Placement Method.

A. Conventional Side Form Paving: The Engineer will check the pavement thickness in accordance with the dimensions shown on the plans. The Engineer will perform 1 thickness test consisting of 1 reading at approximately the center of the paving equipment

every 500 feet or fraction thereof. All deficiencies from plan thickness shall be corrected prior to concrete placement.

- B. Slip Form Paving: The Engineer will check the pavement thickness in accordance with TxDOT's Test Procedure Tex-423-A. The Engineer will perform 1 thickness test consisting of 1 reading at approximately the center of the paving equipment every 500 feet or fraction thereof. Verify deficiencies of more than 0.2 inches from plan thickness and determine the limits of deficiencies of more than 0.75 inches from plan thickness by coring. Core where directed, in accordance with ASTM C174 "Standard Test Method for Measuring Thickness of Concrete Elements Using Drilled Concrete Cores." Fill core holes using a concrete mixture and method approved by the Engineer.

Thickness Deficiencies Greater than 0.2 inches. When any depth test measured in accordance with Tex-423-A is deficient by more than 0.2 inches from the plan thickness, take one core at that location to verify the measurement.

If the core is deficient by more than 0.2 inches but less than 0.75 inches from the plan thickness, take 2 additional cores from the unit (500 foot length) at intervals of at least 150 feet and at locations selected by the Engineer, and determine the thickness of the unit for payment purposes by averaging the lengths of the 3 cores. (See Table for "Deficient Pavement Thickness price Adjustment Factor").

Thickness Deficiencies Greater than 0.75 inches. If a core is deficient by more than 0.75 inches, take additional cores at 10 foot intervals in each direction parallel to the centerline to determine the boundary of the deficient area. The Engineer will evaluate any area of pavement found deficient in thickness by more than 0.75 inches. As directed, the Contractor shall remove and replace the deficient areas with concrete pavement of thickness shown on the plans, without additional compensation.

Pavement Units for Payment Adjustment. Limits for applying a payment adjustment for deficient pavement thickness from 0.20 inches to not more than 0.75 inches are 500 feet of pavement in each lane. Lane width will be shown on typical sections and pavement design standards.

For pavement thickness deficiencies greater than 0.75 inches, the limits for requiring removal will be defined by coring as determined by the Engineer. The remaining portion of the unit determined to be less than 0.75 inches deficient will be subject to the payment adjustment based on

the average core thickness at each end of the 10 foot interval investigation as determined by the Engineer.

Shoulders will be measured for thickness unless otherwise shown on the plans. Shoulders 6 feet wide or wider will be considered as lanes. Shoulders less than 6 feet wide will be considered part of the adjacent lane.

Limits for applying payment adjustment for deficient pavement thickness for ramps, widenings, acceleration and deceleration lanes, and other miscellaneous areas are 500 feet in length. Areas less than 500 feet in length will be individually evaluated for payment adjustment based on the plan area.

TABLE FOR DEFICIENT PAVEMENT THICKNESS PRICE
ADJUSTMENT FACTOR

DEFICIENCY IN THICKNESS DETERMINED BY CORES IN INCHES	PROPORTIONAL PART CONTRACT PRICE ALLOWED
0.00 to 0.20	100 Percent
0.21 to 0.30	80 Percent
0.31 to 0.40	72 Percent
0.41 to 0.50	68 Percent
0.51 to 0.75	57 Percent
Over 0.75	Remove and Replace

Any area found deficient in thickness by more than 0.75 inches shall be removed and replaced, at the Contractor's entire expense, with concrete of the thickness shown on drawings.

No additional payment over the contract unit price will be made for any pavements of a thickness exceeding that required on drawings and planing of concrete pavement shall not be allowed.

360.19 Non-Conforming Concrete. Any concrete deemed non-conforming, which in the opinion of the Engineer is unsatisfactory, shall be removed and replaced at the expense of the Contractor.

360.20 Quality Assurance. The Testing Laboratory's representative will sample concrete delivered to the site in accordance with ASTM C172 and will mold four specimens for each 150 cubic yards. Each time a set of specimens is molded, the slump will be determined in accordance with ASTM C143 and the air content in accordance with ASTM C173

“Standard Test Method for Air Content of Freshly Mixed Concrete by the Volumetric Method” or ASTM C231 “Standard Test Method for Air Content of Freshly Mixed Concrete by the Pressure Method.” Concrete cores, if required, shall be tested in accordance with ASTM C174 (9 point procedure) and ASTM C39.

360.21 Measurement. Concrete pavement shall be measured by the square yard of the specified mix design and thickness of completed and accepted pavement. Dowels, when required, are incidental to this Item, and do not require measurement.

360.22 Payment. The work performed and the materials furnished as prescribed by this Item and measured as provided under "Measurement" shall be paid for at the unit price bid for "Concrete Pavement", or "Concrete Pavement, High Early Strength", as required, or the adjusted unit price for pavement of deficient thickness as provided under "Penalty for Deficient Pavement Thickness", which price shall be full compensation for shaping and fine grading the roadbed, including furnishing and applying all water required; for furnishing, loading and unloading, storing, handling all concrete ingredients, including all freight and royalty involved; for mixing, placing, finishing and curing all concrete; for furnishing all materials for and placing longitudinal, warping, expansion, sawed control and contraction joints, and load transmission units, and joint filler material in proper position; for coating steel bars where required by plans, for furnishing and placing all reinforcing steel, for drilling dowel holes in the existing concrete pavement, providing and installing dowels and epoxy grouting them where required by the plans; and for all manipulations, labor, equipment, appliances, tools, traffic provisions and incidentals necessary to complete the work.

There are line code(s), description(s) and unit(s) for this Item.

NOTE: This Item requires other Standard Specifications

Item 205 “Subgrade”
Item 421 “Structural Concrete”
Item 440 “Reinforcing Steel”
Item 526 “Membrane Curing”

END OF ITEM 360

GENERAL NOTES:

- ALL EXISTING ROADWAY MATERIAL REMOVED AND EXCESS SOIL MATERIAL EXCAVATED FROM ROADWAY SHALL BECOME THE PROPERTY OF THE CONTRACTOR AND SHALL BE PROPERLY DISPOSED OF OFF SITE.
- OTHER CONTRACTOR WILL FURNISH AND MAINTAIN BARRICADES, WARNING SIGNS AND TRAFFIC CONTROL DEVICES AS PER LATEST TEXAS MUTCD AND TYPICAL CONSTRUCTION LAYOUTS OR AS DIRECTED BY THE ENGINEER.
- ADVANCED WARNING SIGNS ARE TO BE SET TWO WEEKS PRIOR TO CONSTRUCTION AND REMAIN IN PLACE UNTIL ALL CONSTRUCTION ACTIVITIES ARE COMPLETE AND ACCEPTED.
- THE CONTRACTOR WILL NOT BLOCK TRAFFIC WITHOUT PRIOR APPROVAL OF THE ENGINEER.
- ACCESS TO BUSINESS AND PRIVATE PROPERTIES SHALL BE CONTINUOUSLY MAINTAINED EXCEPT FOR SHORT PERIODS DURING CONSTRUCTION OPERATIONS. INGRESS OR EGRESS SHALL BE PROVIDED AT DRIVEWAYS AS SOON AS PRACTICAL UPON COMPLETION OF WORK.
- EQUIPMENT SHALL BE OFF STREETS BY DARK AND BEFORE DAWN.
- POSITIVE DRAINAGE SHALL BE MAINTAINED AT ALL TIMES.
- FLAGMAN WILL BE PROVIDED BY CONTRACTOR AS REQUIRED TO MAINTAIN TRAFFIC/PUBLIC SAFETY AT THE DISCRETION OF THE ENGINEER.
- CONTRACTOR SHALL USE REASONABLE PRACTICAL METHODS TO CONTROL DUST AND TO REMOVE MATERIAL FROM EXISTING PAVED SURFACES.
- THE LOCATION OF EXISTING UNDERGROUND UTILITIES AND SERVICE LINES AS INDICATED ON THIS DRAWING SHALL BE MAINTAINED THROUGHOUT CONSTRUCTION. CONTRACTOR SHALL LOCATE AND REMOVE ALL OBSTACLES TO CONSTRUCTION AHEAD OF EXCAVATION.
- CONTRACTOR SHALL PROTECT EXISTING UNDERGROUND UTILITIES/FACILITIES DURING INSTALLATION OF PROPOSED WORK. ANY DAMAGE TO EXISTING UTILITIES/UTILITIES WILL BE THE CONTRACTOR'S RESPONSIBILITY.
- PAVED SURFACES SHALL BE PROTECTED FROM DAMAGE BY CONSTRUCTION EQUIPMENTS.
- IRON RODS OR CORNER MONUMENTS DISTURBED DURING CONSTRUCTION TO BE REPLACED BY REGISTERED PUBLIC LAND SURVEYOR TO ORIGINAL PROPERTY CORNER AT NO SEPARATE PAY.
- CONTRACTOR SHALL CONTACT THE ENGINEER AND THE CITY OF BAYOU VISTA AT LEAST 48 HOURS PRIOR TO CONSTRUCTION FOR NOTICE OF COMMENCEMENT.
- STARTING CONSTRUCTION, ALL PROPERTY OWNERS A MINIMUM OF 24 HOURS PRIOR TO CONTRACTOR TO REMOVE AND REPLACE EXISTING FENCES, POSTS, PLANTERS, MAIL BOXES AND TRASH CONTAINERS AS REQUIRED TO COMPLETE THE WORK.
- ANY TEMPORARY STREET CROSSOVERS REQUIRED BY CONTRACTOR, WILL BE AT CONTRACTOR'S EXPENSE. PRIOR APPROVAL BY ENGINEER IS REQUIRED.
- ALL PROJECT WORK SCHEDULE AND CONSTRUCTION METHODS WILL NEED PRIOR APPROVAL BY ENGINEER.
- CONTRACTOR SHALL BE EQUIPPED WITH THE SPREADER, WHICH SHALL BE CAPABLE OF SPREADING AND FINISHING SURFACE COURSE OF 3" IMC AND BASE COURSE OF 9" COLD-IN-PLACE IN FULL WIDTH OF THE PROPOSED PAVEMENT. CONTRACTOR SHALL MAINTAIN A MINIMUM COURSE AND BASE COURSE IN ONE FULL WIDTH OF THE PROPOSED PAVEMENT.

CENTERPOINT ENERGY FACILITIES

- CAUTION: UNDERGROUND GAS FACILITIES**
 THE LOCATION OF AT&T TEXAS/SWBT FACILITIES ARE SHOWN IN AN APPROXIMATE WAY ONLY. THE CONTRACTOR SHALL DETERMINE THE EXACT LOCATION BEFORE COMMENCING WORK. HE AGREES TO BE FULLY RESPONSIBLE FOR ANY AND ALL DAMAGES WHICH MAY BE OCCURRED BY THIS FAILURE TO EXACTLY LOCATE AND PRESERVE THESE UNDERGROUND UTILITIES.
- WHEN CENTERPOINT ENERGY PIPELINE MARKERS ARE NOT VISIBLE, CALL (713) 207-5463 OR 713-945-9037 (7:00 AM TO 4:30 P.M.) FOR STATUS OF THE LINE LOCATION REQUEST BEFORE EXCAVATION BEGINS.
 - WHEN CENTERPOINT ENERGY FACILITIES ARE EXPOSED, SUFFICIENT SUPPORT MUST BE PROVIDED TO THE FACILITIES TO PREVENT EXCESSIVE STRESS OR DEFORMATION.
 - FOR EMERGENCIES REGARDING GAS LINES CALL 713-658-3538 OR 713-207-4200.
- THE CONTRACTOR IS FULLY RESPONSIBLE FOR ANY DAMAGES CAUSED BY HIS FAILURE TO EXACTLY LOCATE AND PRESERVE THESE UNDERGROUND FACILITIES.
- WARNING: OVERHEAD ELECTRICAL LINES**
- OVERHEAD LINES MAY EXIST ON THE PROPERTY. THE LOCATION OF OVERHEAD LINES HAS NOT BEEN SHOWN ON THESE DRAWINGS AS THE LINES ARE CLEARLY VISIBLE, BUT YOU SHOULD LOCATE THEM PRIOR TO BEGINNING ANY CONSTRUCTION. TEXAS LAW, SECTION 752, HEALTH & SAFETY CODE PROHIBITS ACTIVITIES THAT OCCUR IN CLOSE PROXIMITY TO HIGH VOLTAGE LINES, SPECIFICALLY:
 - ANY ACTIVITY WHERE PERSON OR THINGS MAY COME WITHIN SIX(6) FEET OF LIVE OVERHEAD HIGH VOLTAGE LINES; AND
 - OPERATING ANY POWER TOOL, DRILLING BIG, RIG, PILE DRIVER, HOISTING OR OPERATING ANY SIMILAR APPARATUS WITHIN 10 FEET OF LIVE OVERHEAD HIGH VOLTAGE LINES.
- PARTIES RESPONSIBLE FOR THE WORK, INCLUDING CONTRACTORS ARE LEGALLY RESPONSIBLE FOR THE SAFETY OF CONSTRUCTION WORKERS UNDER THIS LAW. THIS LAW CARRIES BOTH CIVIL AND CRIMINAL PENALTIES. THE CONTRACTOR IS TO BE TURNED OFF ON REMOVED CALL CENTERPOINT ENERGY AT (713) 207-2222.

AT&T TEXAS/SWBT FACILITIES

- THE LOCATIONS OF AT&T TEXAS/SWBT FACILITIES ARE SHOWN IN AN APPROXIMATE WAY ONLY. THE CONTRACTOR SHALL DETERMINE THE EXACT LOCATION BEFORE COMMENCING WORK. HE AGREES TO BE FULLY RESPONSIBLE FOR ANY AND ALL DAMAGES WHICH MAY BE OCCURRED BY THIS FAILURE TO EXACTLY LOCATE AND PRESERVE THESE UNDERGROUND UTILITIES.
 - THE CONTRACTOR SHALL CALL 1-800-344-8377 (TEXAS 811) A MINIMUM OF 48 HOURS PRIOR TO CONSTRUCTION TO HAVE MAJOR UNDERGROUND LINES FIELD LOCATED.
 - WHEN EXCAVATING WITHIN EIGHTEEN INCHES (18") OF THE INDICATED LOCATION OF THE AT&T TEXAS/SWBT FACILITIES, ALL EXCAVATIONS MUST BE ACCOMPLISHED USING NON-MECHANIZED EXCAVATION PROCEDURES. WHEN BORING, THE CONTRACTOR SHALL EXPOSE THE AT&T TEXAS/SWBT FACILITIES.
 - WHEN AT&T TEXAS/SWBT FACILITIES ARE EXPOSED, CONTRACTOR TO WILL PROVIDE SUPPORT TO PREVENT DAMAGE TO THE CONDUIT DUCTS OR CABLES. WHEN EXCAVATING NEAR TELEPHONE POLES, THE CONTRACTOR SHALL BRACE THE POLE FOR SUPPORT.
 - THE PRESENCE OR ABSENCE OF AT&T TEXAS/SWBT UNDERGROUND CONDUIT FACILITIES OR BURIED CABLE FACILITIES SHOWN ON THESE PLANS DOES NOT MEAN THAT THERE ARE NO DIRECT BURIED CABLE OR OTHER CABLES IN CONDUIT IN THE AREA.
 - PLEASE CONTACT THE AT&T TEXAS DAMAGE PREVENTION MANAGER MR. ROOSEVELT LEE JR. AT (713)267-4552 OR E-MAIL HM AT BL229@ATT.COM IF THERE ARE QUESTIONS ABOUT BORING OR EXCAVATING NEAR OUR AT&T TEXAS/SWBT FACILITIES.
- OTHER NOTES**
- UNDERGROUND PIPELINES ARE SHOWN ACCORDING TO BEST AVAILABLE INFORMATION. CONTRACTOR TO PROCEED WITH CAUTION DURING EXCAVATION. CONTRACTOR TO COORDINATE WITH PRELINE OWNER IN CASE OF CONFLICTS OR QUESTIONS. CONTRACTOR TO VERIFY LOCATION OF UNDERGROUND UTILITIES BY CONTACTING THE UTILITY COORDINATING COMMITTEE FORTY-EIGHT (48) HOURS BEFORE BEGINNING WORK AT 1 (800) 345-8003 OR 811.
 - ALL EXISTING UNDERGROUND UTILITIES ARE NOT GUARANTEED TO BE CORRECT OR DEFINE THE APPROXIMATE LOCATIONS OF KNOWN UNDERGROUND UTILITIES. CONTRACTOR SHALL DETERMINE THE EXACT SIZE AND HORIZONTAL AND VERTICAL LOCATIONS IN THE FIELD PRIOR TO COMMENCING WORK.
 - ANY PERMANENT RELOCATION OF AN EXISTING UTILITY NOT SHOWN ON THE DRAWINGS SHALL BE APPROVED BY THE ENGINEER PRIOR TO RELOCATION AND SHALL CONFORM TO THE APPLICABLE STANDARDS OF GOVERNING AUTHORITIES.
 - CONTRACTOR SHALL PROTECT EXISTING UNDERGROUND FACILITIES DURING INSTALLATIONS OF PROPOSED WORK.

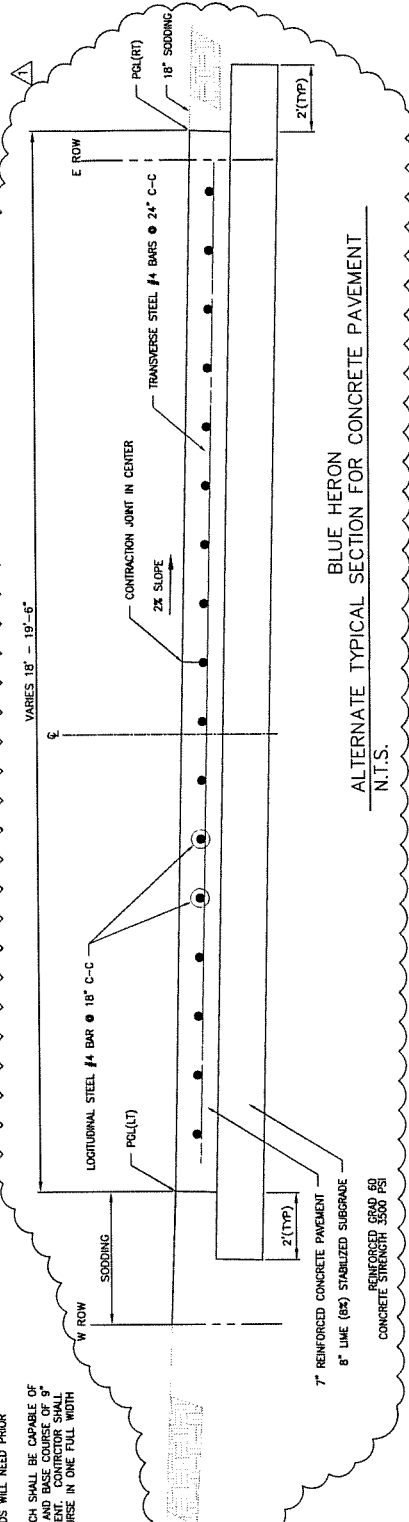

BLUE HERON
ALTERNATE TYPICAL SECTION FOR CONCRETE PAVEMENT
 N.T.S.

PROJECT TITLE: BLUE HERON DRIVE
 DRAWN BY: GENERAL NOTES
 CHECK BY: SHEET REVISIONS
 SCALE: ALTERNATE TYPICAL SECTION
 DATE: FOR CONCRETE PAVEMENT
 APPROVED BY: 10/15/2020

Zarinkelk
 Engineering Services, Inc.
 11111 Katy Road
 Houston, TX 77058
 Tel: 281.222.2222
 Fax: 281.222.2222

GALVESTON COUNTY
ENGINEERING
DEPARTMENT

NO.	REVISIONS	DATE	NAME
1	1/5 FOR ALTERNATE CONCRETE PAVEMENT	10/14/20	PHF
ADDITION # 1			

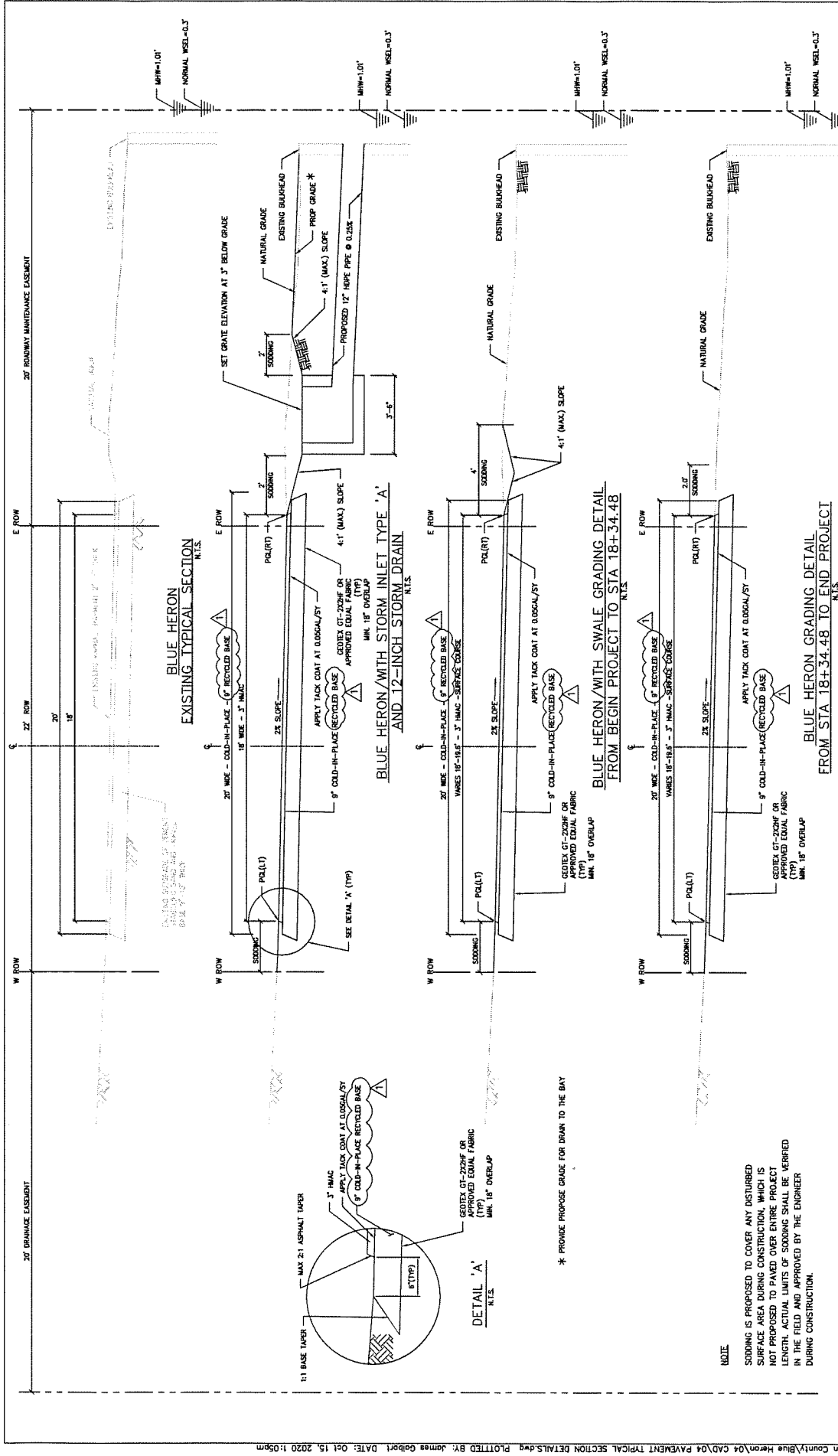

NO.	REVISIONS	DATE	NAME
	REVISED FROM "BLACK" TO "CYCLIC"	10/14/20	PHP
ADDRESS/NO. # 1			
GALVESTON COUNTY ENGINEERING DEPARTMENT			
PROJECT TITLE: BLUE HERON DRIVE			
DRAWN BY: [blank]			
SHEET DESCRIPTION: TYPICAL SECTIONS			
SCALE: [blank]			
DATE: 10/15/2020			
APPROVED BY: [blank]			
PROJECT ID: B001			
SHEET NO: 4 / 30			

