



SENIOR FACILITIES • HOSPITALS • REHABILITATION CENTERS • SPECIAL NEEDS

Wellness is not about competing, it's about exercising; both body and mind. Exercising movements are slower and more natural. Training is focused on balance and coordination and activities to support ordinary daily life.

- 37% of the population over 75 years of age lives alone and their independence in day to day activities is affected by loss of agility, coordination and balance, and a slowing down of movement.
- One out of three adults age 65 and older falls each year, but less than half talk to their healthcare provider about it.
- Among older adults (those 65 and older), falls are the leading cause of death from injury. They are also the most common cause of nonfatal injuries and hospital admissions for trauma.

Health Benefits

- stretching of the muscles
- increased range of motion
- cardio respiratory
- blood circulation
- balance work
- walking exercises
- motor coordination
- hand eye coordination
- proprioception work (adapting feet to different surfaces)
- column exercises
- muscle strength work
- adaptation to daily activities



Senior Care

Fall prevention, independence and healthy active ageing

- Fall prevention assessment and training tool
- Improving and maintaining mobility, flexibility and balance skills
- Stimulate social interaction
- Supports constructive challenge in a safe and controlled environment.
- Holistic, mind-body approach to improved activities of daily living

Hospitals / Rehab Market

Facilitating Body & Mind connection, independency and healthy active living

- Improving post injury mobility, flexibility and balance skills
- Improve post injury challenged daily activities
- Help regaining independence and confidence
- Stimulate mind-body connection
- Cost effective approach to physiotherapy with high ROI

Special Needs

Engaging Body & Mind connection, independency and brain stimulation

- Safe approach for Improving mobility, balance and focus skills
- Repetitive, calming motions and activities to stimulate hyper or hypo activity
- Engage sensorial, physical and cognitive activities
- Stimulate mind-body connection
- Encourage independence



GOLD PACKAGE
49401 for outdoor or indoor 

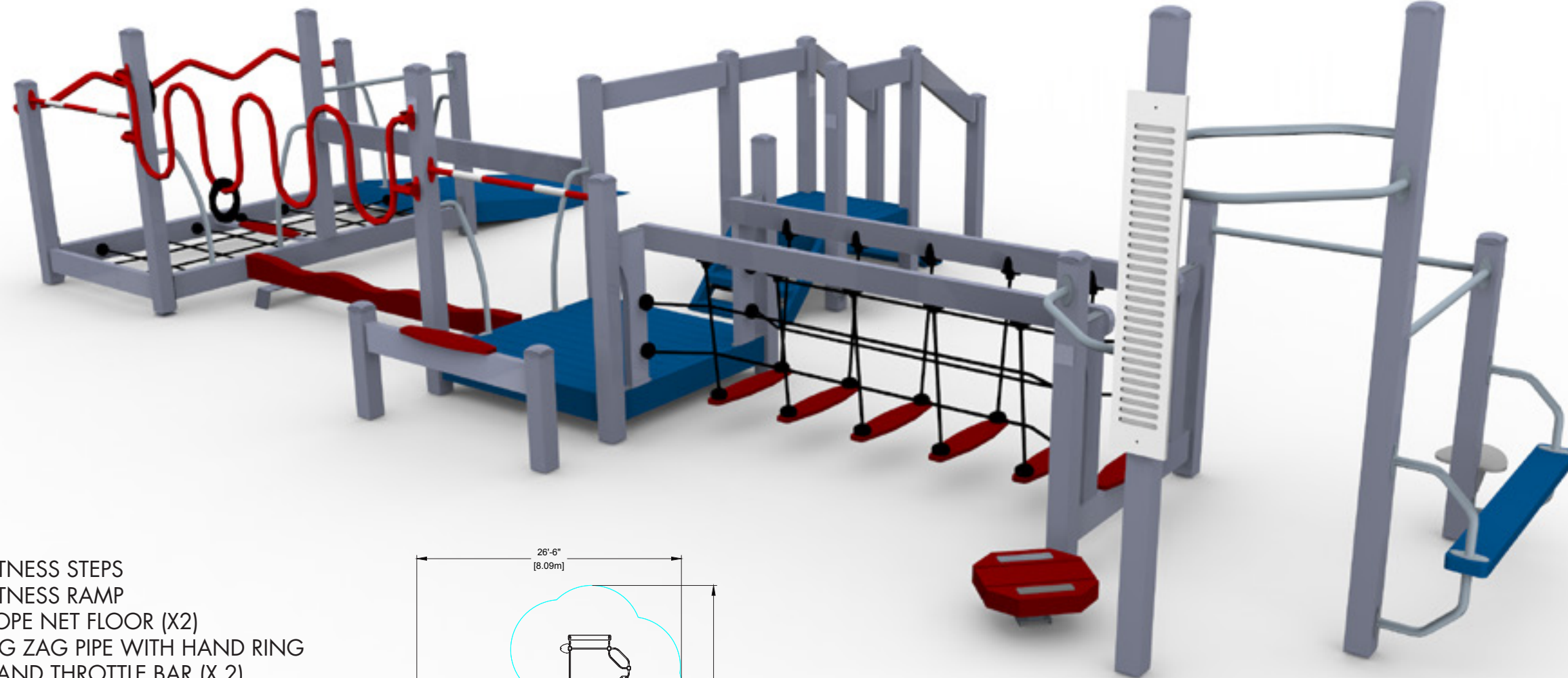

- FITNESS STEPS
- FITNESS RAMP
- ROPE NET FLOOR (X2)
- ZIG ZAG PIPE WITH HAND RING
- HAND THROTTLE BAR (X 2)
- SNAKE PIPE WITH HAND RING
- BALANCE BEAM
- HAND AND DIAL TURN (X 3)
- ROPE BRIDGE WALK
- STRETCHING BOARD (X 2)
- BENCH SIT UP AND BENCH PUSH UP BAR
- HIGH CHIN UP BARS (X 2)
- BALANCE AND HIP TWIST
- STRETCH AND LOW PUSH UP BAR

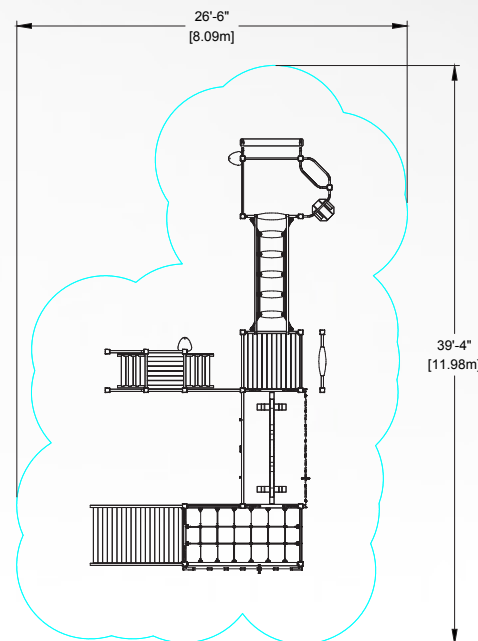

MORE THAN 600 UNITS INSTALLED WORLD-WIDE

CONCEPT BY
LAPPSET®

XCENFITNESS.COM

800.933.4748

SILVER PACKAGE

49399 for outdoor or indoor 

- STRETCHING BOARD
- HAND DIAL TURN (X 3)
- BALANCE BEAM
- HAND-EYE TRACER
- SNAKE PIPE WITH HAND RING
- HAND THROTTLE BAR
- TRAINING TABLE

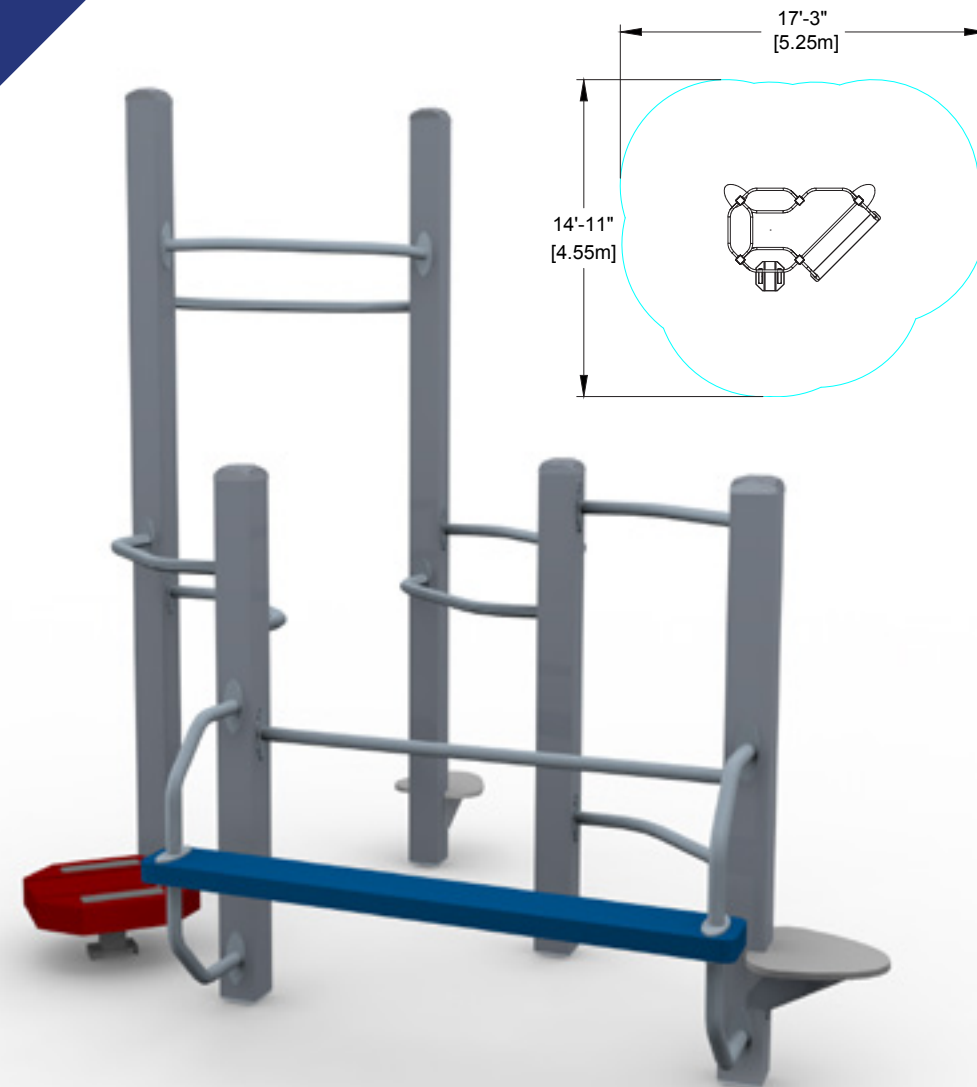
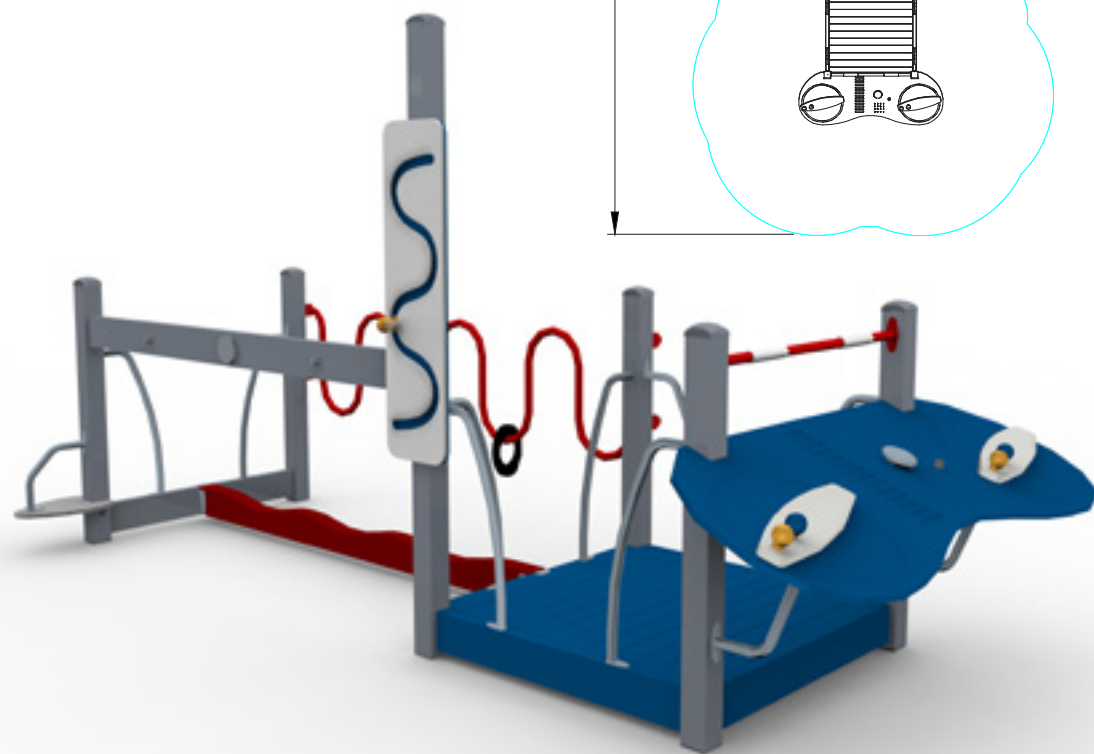
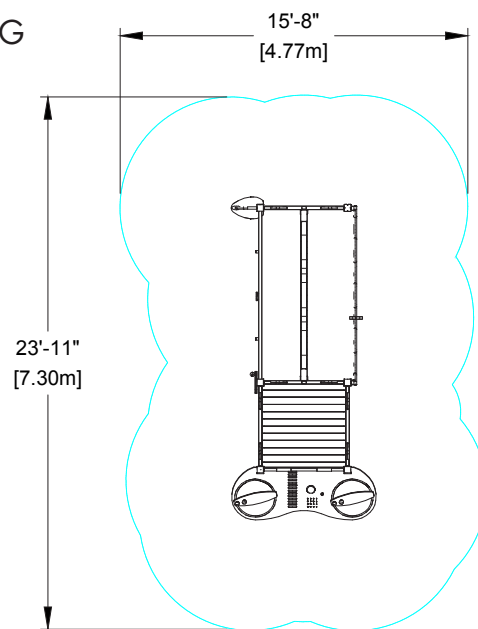

BRONZE PACKAGE

for outdoor or indoor 49398

- BALANCE AND HIP TWIST
- BENCH WITH LOW CHIN UP BAR AND PUSH UP BAR
- STRETCHING BOARD (X 2)
- STRETCH AND LOW PUSH UP BAR
- HIGH CHIN UP BAR (X 2)





**"We don't stop playing because we grow old;
we grow old because we stop playing."
George Bernard Shaw**

CONCEPT BY
LAPPSET®

XCENFITNESS.COM

800.933.4748



5240 257th Street
Wyoming, MN 55092

651.462.9200

800.933.4748

INFO@XCCENTFITNESS.COM