

**GALVESTON COUNTY
PURCHASING DEPARTMENT**



REQUEST FOR PROPOSAL

RFP #B221004

MENTAL HEALTH COURT PUBLIC DEFENDER'S OFFICE BUILDOUT

PROPOSAL DUE DATE: 11/18/2021

2:15 P.M. CST

***Rufus Crowder, CPPO, CPPB
Purchasing Agent
Galveston County
722 Moody (21st Street)
Fifth (5th) Floor
Galveston, Texas 77550
(409) 770-5372***



**REQUEST FOR PROPOSAL
MENTAL HEALTH COURT PUBLIC DEFENDER'S OFFICE BUILDOUT
GALVESTON COUNTY, TEXAS**

Purpose:

Galveston County is seeking a contractor to remodel the former Housing Department Suite on the 6th Floor of the Galveston County Courthouse, 722 Moody, (21st Street), Galveston, TX 77550.

Sealed proposals in **sets of six (6), one (1) unbound original and five (5) copies**, will be received in the office of the Galveston County Purchasing Agent **until 2:15 P.M. CST, on Thursday, November 18, 2021**, and opened immediately in that office in the presence of Galveston County Auditor and the Purchasing Agent. Sealed submittals are to be delivered to Rufus G. Crowder, CPPO CPPB, Galveston County Purchasing Agent at the Galveston County Courthouse, 722 Moody, (21st Street), Floor 5, Purchasing, Galveston, Texas 77550, (409) 770-5372.

The time stamp clock located in the Purchasing Agent's office shall serve as the official time keeping piece for this solicitation process. Any proposals received after 2:15 P.M. CST on the specified date will be returned unopened.

All proposals must be marked on the outside of the sealed envelope:
RFP #B221004, Mental Health Court Public Defender's Office Buildout

Proposer's name, return address, should be prominently displayed on the proposal package for identification purposes.

Procurement Timeline:

A timeline for this RFP and initial process is included below. Galveston County reserves the right to amend these dates and will notify proposers of any changes via an addendum posted on the County's Purchasing Department's website and www.CivCast.com:

- | | |
|---|--|
| • Advertise RFP (first date of publication) | Thursday, October 21, 2021 |
| • Advertise RFP (second date of publication) | Thursday, October 28, 2021 |
| • Deadline for Questions & Inquiries | Wednesday November 3, 2021, by 5:00 p.m. |
| • Submission Deadline / RFP Opening | Thursday, November 18, 2021, at 2:15 p.m. |

Interested parties may attend the Thursday, November 18, 2021, 2:15 bid opening virtually by using the following link:

<https://galvestoncountytexas.webex.com/galvestoncountytexas/j.php?MTID=mb7bcfc438ea82c165814609ccde76c28>

Join by meeting number

Meeting number (access code): 2487 440 7765

Meeting password: B221004

Tap to join from a mobile device (attendees only)
+1-415-655-0001,,24874407765## US Toll

Join by phone
+1-415-655-0001 US Toll
Global call-in numbers

Join from a video system or application
Dial 24874407765@galvestoncountytexas.webex.com

You can also dial 173.243.2.68 and enter your meeting number.

Plans and Specifications: Specifications can be obtained by visiting the Galveston County website @ <http://www.galvestoncountytexas.gov/county-offices/purchasing>

Pricing: Submitted prices, if required and applicable, shall be either lump sum or unit prices as shown on proposal sheets. The net price shall be delivered to Galveston County, including all freight, shipping, and license fees. Galveston County is tax exempt, and no taxes should be included in proposal pricing.

Bonding Requirements:

- **PROPOSAL GUARANTEE:** Evidencing its firm commitment to engage in the contract if Proposer is selected for award of contract, each Proposer is required to furnish with their proposal a Cashier's Check, or an acceptable Bidder's Bond, in the amount of five percent (5%) of the total contract price. The Bidder's Bond must be executed with a surety company authorized to do business in the State of Texas. Failure to furnish the bid/proposal guarantee in the proper form and amount, by the time set for opening of bids may be cause or rejection of the proposal.
- **PERFORMANCE AND PAYMENT BONDS:** Successful proposer, before beginning work, shall execute a performance bond and a payment bond, each of which must be in the amount of the contract. The required payment and performance bonds must each be executed by a corporate surety in accordance with Section 1, Chapter 87, Acts of the 56th Legislature, Regular Session, 1959 (Article 7.19-1, Vernon's Texas Insurance Code).

Davis-Bacon Wage Rates:

Attention is called to the fact that not less than, the federally determined prevailing (Davis-Bacon and Related Acts) wage rate, as issued by the Office of Rural Community Affairs and contained in the contract documents, must be paid on this project. In addition, the successful bidder must ensure that employees and applicants for employment are not discriminated against because of race, color, religion, sex age or national origin.

Debarment and Suspension:

All contractors/subcontractors that are debarred, suspended or otherwise excluded from or ineligible for participation on federal assistance programs may not undertake any activity in part or in full under this project.

The Galveston County Commissioners' Court reserves the right to waive any informality and to reject any and all bids and to accept the bid or bids which, in its opinion, is most advantageous to Galveston County with total respect the governing laws.

Rufus G. Crowder, CPPO CPPB
Purchasing Agent
Galveston County

**REQUEST FOR PROPOSALS
MENTAL HEALTH COURT PUBLIC DEFENDER’S OFFICE BUILDOUT
GALVESTON COUNTY, TEXAS**

Table of Contents

GENERAL PROVISIONS:

1. RFP PACKAGE..... 1

2. RESPONDER’S RESPONSIBILITY 1

3. TIME FOR RECEIVING RFPS 2

4. COMPETITIVENESS, INTEGRITY, INQUIRIES AND QUESTIONS..... 2

5. RFP OPENING 3

6. WITHDRAWAL OF RFP/FIRM RFP RULE..... 3

7. COMMISSIONERS’ COURT 3

8. REJECTION OF RFPS/DISQUALIFICATION..... 4

9. RESTRICTIVE OR AMBIGUOUS SPECIFICATIONS..... 4

10. SUBSTITUTES/DESCRIPTION OF MATERIALS AND EQUIPMENT 4

11. EXCEPTIONS TO RFP 5

12. PRICING..... 5

13. PROCUREMENT CARD (P-CARD) PROGRAM 5

14. PASS THROUGH COST ADJUSTMENTS..... 5

15. MODIFICATION OF RFPS 6

16. PRE-RFP CONFERENCE..... 6

17. SIGNATURE OF RFPS 6

18. AWARD OF RFPS – EVALUATION CRITERIA AND FACTORS 7

19. DISPUTE AFTER AWARD/PROTEST..... 8

20. PUBLIC INFORMATION ACT (F/K/A OPEN RECORDS ACT) 9

21. RESPONDER’S E-MAIL ADDRESSES – CONSENT TO DISCLOSURE 9

22. RESULTANT CONTRACT 9

23. CONTRACT TERM 10

24. TERMINATION FOR DEFAULT 10

25. TERMINATION FOR CONVENIENCE..... 10

26. FORCE MAJEURE 11

27. ESTIMATED QUANTITIES..... 11

28. CONTRACTOR INVESTIGATION..... 11

29. NO COMMITMENT BY COUNTY OF GALVESTON 11

**REQUEST FOR PROPOSALS
MENTAL HEALTH COURT PUBLIC DEFENDER’S OFFICE BUILDOUT
GALVESTON COUNTY, TEXAS**

30. RFP COSTS BORNE BY RESPONDER..... 11

31. BEST AND FINAL OFFERS (BAFO)..... 12

32. SINGLE RFP RESPONSE..... 12

33. CHANGES IN SPECIFICATIONS 12

34. RFP IDEAS AND CONCEPTS..... 12

35. RFP DISCLOSURES 12

36. INDEMNIFICATION 13

37. REQUIREMENT OF AND PROOF OF INSURANCE..... 13

38. RFP GUARANTEE..... 15

39. PERFORMANCE AND PAYMENT BONDS (IF REQUIRED) 15

40. PATENT AND COPYRIGHT PROTECTION 16

41. CONFLICT OF INTEREST DISCLOSURE REPORTING (FORM CIQ) 16

42. DISCLOSURE OF INTERESTED PARTIES/FORM 1295..... 17

43. CERTIFICATION REGARDING DEBARMENT, SUSPENSION, PROPOSED DEBARMENT, AND OTHER
RESPONSIBILITY MATTERS & REQUIREMENT TO REGISTER IN SAM..... 18

44. TRANSACTIONS WITH TERRORIST ORGANIZATIONS PROHIBITED 19

45. VERIFICATION NOT TO BOYCOTT ISRAEL 20

46. SOVEREIGN IMMUNITY..... 20

47. CONTROLLING LAW AND VENUE 20

48. MERGERS, ACQUISITIONS 20

49. DELAYS..... 21

50. ACCURACY OF DATA 21

51. SUBCONTRACTING/ASSIGNMENT..... 21

52. INDEPENDENT CONTRACTOR 21

53. MONITORING PERFORMANCE 22

54. SUBJECT TO APPROPRIATION OF FUNDS 22

55. CONTRACTS SUBJECT TO GRANT FUNDING..... 22

56. PROCUREMENT ETHICS..... 22

57. NON-COLLUSION AFFIDAVIT..... 24

58. CERTIFICATION REGARDING LOBBYING – COMPLIANT WITH APPENDIX A TO 24 C.F.R. PART 871.. 25

59. NON-DISCRIMINATION 25

60. RECORD RETENTION AND RIGHT TO AUDIT..... 26

61. TITLE VI ASSURANCES/TXDOT..... 26

62. ASSURANCES FOR CONSTRUCTION PROGRAMS - TEXAS GENERAL LAND OFFICE (GLO)..... 28

**REQUEST FOR PROPOSALS
 MENTAL HEALTH COURT PUBLIC DEFENDER’S OFFICE BUILDOUT
 GALVESTON COUNTY, TEXAS**

63. GENERAL AFFIRMATIONS – TEXAS GENERAL LAND OFFICE (GLO).....	30
64. SECTION 231.006, FAMILY CODE/DELINQUENT CHILD SUPPORT	36
65. ANTITRUST	37
66. LABOR STANDARDS.....	37
67. PROCUREMENT STANDARDS -.....	37
2 C.F.R. § 200.317. PROCUREMENTS BY STATES.....	37
2 C.F.R. § 200.318. GENERAL PROCUREMENT STANDARDS.....	38
2 C.F.R. § 200.319. COMPETITION.....	40
2 C.F.R. § 200.320. METHODS OF PROCUREMENT TO BE FOLLOWED.....	41
2 C.F.R. § 200.321. CONTRACTING WITH SMALL AND MINORITY BUSINESSES, WOMEN'S BUSINESS ENTERPRISES, AND LABOR SURPLUS AREA FIRMS.....	43
2 C.F.R. § 200.322. PROCUREMENT OF RECOVERED MATERIALS.....	43
2 C.F.R. § 200.323. CONTRACT COST AND PRICE.....	44
2 C.F.R. § 200.324. FEDERAL AWARING AGENCY OR PASS-THROUGH ENTITY REVIEW.....	44
69 FR 26280, MAY 11, 2004; 78 FR 78608, DEC. 26, 2013, UNLESS OTHERWISE NOTED.....	45
2 C.F.R. § 200.325. BONDING REQUIREMENTS.....	45
69 FR 26280, MAY 11, 2004; 78FR 78608, DEC. 26, 2013, UNLESS OTHERWISE NOTED	45
2 C.F.R. § 200.326. CONTRACT PROVISIONS.....	45
2 C.F.R. PART, 200, APPENDIX II.....	46
68. PROCUREMENT LAWS	49
70. REQUIRED CONTRACT PROVISIONS.....	56
ACCESS TO RECORDS & RECORD RETENTION (2 CFR 200.336).....	56
ACCESSIBILITY (24 CFR 570.614) & SECTION 504 (29 U.S.C. SECTION 794 AND 24 CFR PARTS 8-9)	56
BYRD ANTI-LOBBYING AGREEMENT (2 CFR 200 APPENDIX II (J) AND 24 CFR 570.303)	57
CIVIL RIGHTS ACT OF 1964 (TITLE VI 42 U.S.C. § 2000D).....	57
CLEAN AIR ACT (2 CFR APPENDIX II TO PART 200 (G)).....	58
CONTRACT WORK HOURS AND SAFETY STANDARDS ACT (2 CFR APPENDIX II TO PART 200 (E)).....	58
COPELAND “ANTI-KICKBACK” ACT (40 U.S.C. 3145)	59
COST PLUS CONTRACTING PROHIBITED (2 CFR 200.323(D)).....	59
DAVIS BACON AND RELATED ACTS (2 CFR 200 APPENDIX II (D))	59
DEBARMENT / SUSPENSION AND VOLUNTARY EXCLUSION (2 CFR APPENDIX II TO PART 200 (I))	60
EQUAL EMPLOYMENT OPPORTUNITY (41 CFR 60-1.4(B) AND 2 CFR 200 APPENDIX II (C))	61
EQUAL EMPLOYMENT OPPORTUNITY FOR WORKERS WITH DISABILITIES (48 CFR 52.22236).....	63
EQUAL EMPLOYMENT OPPORTUNITY FOR VEVRAA PROTECTED VETERANS (41 CFR 60.300)	63
FAIR LABOR STANDARDS ACT.....	67

**REQUEST FOR PROPOSALS
 MENTAL HEALTH COURT PUBLIC DEFENDER’S OFFICE BUILDOUT
 GALVESTON COUNTY, TEXAS**

FLOOD DISASTER PROTECTION ACT OF 1973 (24 CFR 570.605).....	67
GREEN BUILDING STANDARDS.....	67
HOLD HARMLESS AGREEMENT	68
LEAD-BASED PAINT (24 CFR 570.608).....	68
NON-COLLUSION (THE SHERMAN ACT)	68
NON-SEGREGATED FACILITIES.....	69
PARTICIPATION BY MINORITY & WOMEN-OWNED BUSINESS ENTERPRISES (2 CFR 200.321).....	69
POTENTIAL CONFLICTS OF INTEREST.....	70
PREVAILING WAGES (2 CFR 200 APPENDIX II (D) AND TGC 2258).....	70
PROCUREMENT OF RECOVERED MATERIALS (2 CFR 200.322).....	71
PROGRAM FRAUD AND FALSE OR FRAUDULENT STATEMENTS OR RELATED ACTS	71
RESTRICTIONS ON PUBLIC BUILDINGS AND PUBLIC WORKS PROJECTS CERTIFICATION	71
RESTRICTIONS ON PUBLIC BUILDINGS AND PUBLIC WORKS PROJECTS	72
RIGHTS TO INVENTIONS (2 CFR APPENDIX II TO PART 200 (F)).....	73
SECTION 109 OF THE HOUSING AND COMMUNITY DEVELOPMENT ACT OF 1974 (24 CFR 570.602).....	74
TERMINATION FOR CAUSE & CONVENIENCE (2 CFR APPENDIX II TO PART 200 (A) AND (B)).....	74
WHISTLEBLOWER PROTECTION ACT	74
71. NON-EXCLUSIVE LIST OF APPLICABLE LAWS, RULES, AND REGULATIONS – TEXAS GENERAL LAND OFFICE (GLO)	75
72. SPECIAL CONDITIONS – TEXAS GENERAL LAND OFFICE (GLO).....	78
A. REIMBURSEMENT, GENERALLY	78
B. NATIONAL FLOOD INSURANCE PROGRAM COMPLIANCE.....	79
C. PROJECT MAPPING/DESIGN INFORMATION	79
D. WATER SYSTEM IMPROVEMENTS	80
E. SEWER SYSTEM IMPROVEMENTS	80
F. WASTEWATER TREATMENT CONSTRUCTION.....	80
G. SEPTIC SYSTEM IMPROVEMENTS.....	80
H. BUILDING CONSTRUCTION	81
I. BRIDGE CONSTRUCTION/REHABILITATION	81
J. DISASTER SHELTERS.....	81
K. DEBRIS REMOVAL.....	81
L. USE OF BONDS	81
M. PROGRAM GUIDELINES.....	82
O. UNSECURED FORGIVABLE PROMISSORY NOTE (“NOTE”).....	82
73. ENERGY EFFICIENCY (42 U.S.C. 6201 AND 2 CFR 200 APPENDIX II (H))	83
74. LEAD AND ASBESTOS	83
75. USE OF DHS SEAL, LOGO, AND FLAGS PROHIBITED WITHOUT PRIOR APROVAL	84
76. FEDERAL GOVERNMENT NOT A PARTY	84

REQUEST FOR PROPOSALS
MENTAL HEALTH COURT PUBLIC DEFENDER’S OFFICE BUILDOUT
GALVESTON COUNTY, TEXAS

77. PROGRAM FRAUD AND FALSE OR FRAUDULENT STATEMENTS OR RELATED ACTS 84

78. ACKNOWLEDGMENT OF GOVERNMENT RECORD..... 84

79. COMPLIANCE WITH GALVESTON COUNTY PURCHASING POLICIES AND PROCEDURES 84

80. ENTIRETY OF AGREEMENT AND MODIFICATION..... 84

81. NOTICE 84

GENERAL PROVISIONS

REQUEST FOR PROPOSALS MENTAL HEALTH COURT PUBLIC DEFENDER'S OFFICE BUILDOUT GALVESTON COUNTY, TEXAS

The General Provisions and the Special Provisions of this Request for Proposal and the Exhibits attached hereto are made a part of this agreement between the Parties. In the event of a conflict between the General Provisions and the Special Provisions, the terms of the Special Provisions shall control.

1. RFP PACKAGE

*The Request for Proposal, General and Special Provisions, drawings, specifications/line-item details, contract documents, addenda (if any), and the RFP are all part of the RFP package and Resultant Contract. **Statements of Proposals must be submitted in sets of six (6), one (1) unbound original, and five (5) copies,** on the forms provided by the County if County forms are provided and shall include the RFP sheets completed in their entirety and signed by an authorized representative by original signature. Failure to complete and sign the RFP sheets/contract page(s) may disqualify the RFP from being considered by the Commissioners' Court. Any individual signing on behalf of the Responder expressly affirms that he or she is duly authorized to tender this RFP and to sign the RFP under the terms and conditions in this Request for Proposal on behalf of the Responder and to bind the Responder to the terms and conditions of this Request for Proposal and the Responder's response hereto.*

Responder further understands that Responders' signing of the contract shall be of no effect unless the contract is subsequently awarded by the Commissioners' Court and the contract properly executed by the Commissioners' Court.

All figures must be written in ink or typed. Figures written in pencil or with erasures are not acceptable. However, mistakes may be crossed out, corrections inserted, and initialed in ink by the individual signing the RFP. If there are discrepancies between unit prices quoted and extensions, the unit price shall prevail.

Each Responder is required to thoroughly review this entire Request for Proposal package to familiarize themselves with the RFP procedures, the plans and specifications for the requested work, as well as the terms and conditions of the contract the successful Responder will execute with the County.

2. RESPONDER'S RESPONSIBILITY

The Responder must affirmatively demonstrate its responsibility. The Responder must also meet the following minimum requirements:

- A. have adequate financial resources or the ability to obtain such resources as required;
- B. be able to comply with all federal, state, and local laws, rules, regulations, ordinances, and orders regarding this Request for Proposal;
- C. have a satisfactory record of performance;
- D. have a satisfactory record of integrity and ethics; and
- E. be otherwise qualified and eligible to receive an award.

GENERAL PROVISIONS

REQUEST FOR PROPOSALS MENTAL HEALTH COURT PUBLIC DEFENDER'S OFFICE BUILDOUT GALVESTON COUNTY, TEXAS

3. TIME FOR RECEIVING STATEMENTS OF PROPOSALS

Statements of Proposals may be submitted by mail or hand delivered and **must be submitted only to the Galveston County Purchasing Agent**. If by delivery, the Responder must deliver their submittal to the reception desk in the County Purchasing Agent's Office. The delivery and mailing instructions for the Galveston County Purchasing Agent are as follows:

**Rufus Crowder, CPPO CPPB
Galveston County Purchasing Agent
722 Moody, Fifth (5th) Floor
Galveston, Texas 77550**

Statements of Proposals will **not** be accepted by facsimile transmission or by electronic mail (email) **unless superseded by instructions within the Special Provisions section of this solicitation**. Statements of Proposals must be received by the County Purchasing Agent on or before the deadline for the opening of the RFPs. **For clarity, mailing date/postmark is not sufficient – Statements of Proposals must be received by the County Purchasing Agent on or before the deadline.** Late Responses will not be accepted and will be returned to the Responder unopened. Statements of Proposals received prior to the submission deadline will be maintained unopened until the specified time for opening.

The County Purchasing Agent will accept Statements of Proposals from 8:00 a.m. to 5:00 p.m. on each business day up to the submission deadline. Business days do not include Saturdays and Sundays, and do not include other days in which the County is closed for business in observance of holidays or for other reasons.

The time-stamp clock within the County Purchasing Agent's Office shall be the official time clock for the purpose of this solicitation and thus shall be the determinant of whether the RFP was timely received.

The Responder should prominently identify the procurement number and name on the outside of the envelope/ mailing package. If the Responder fails to identify the Request for Proposal number and name on the outside of the envelope as required, the Purchasing Agent will open the envelope for the sole purpose of identifying the solicitation number for which the submission was made. The envelope will then be resealed. No liability will attach to a County office or employee for the premature opening of a RFP.

If a RFP is not submitted, return this Request for Proposal and state reason (s), otherwise your name may be removed from the Purchasing Agent's mailing list.

4. COMPETITIVENESS, INTEGRITY, INQUIRIES AND QUESTIONS

To prevent biased evaluations and to preserve the competitiveness and integrity of the procurement process, **Responders are to direct all communications regarding this Request for Proposal only to the Galveston County Purchasing Agent**, unless otherwise specifically noted.

Do not contact the requesting department. Attempts by offering firms to circumvent this requirement will be viewed negatively and may result in rejection of the RFP of the firm found to be in non-compliance.

GENERAL PROVISIONS

REQUEST FOR PROPOSALS MENTAL HEALTH COURT PUBLIC DEFENDER'S OFFICE BUILDOUT GALVESTON COUNTY, TEXAS

All questions regarding this Request for Proposal must be submitted in writing to:

Rufus Crowder, CPPO CPPB
Purchasing Agent
722 Moody
Fifth (5th) Floor
Galveston, Texas 77550
Fax: (409) 621-7997
E-mail: purchasing.RFPs@co.galveston.tx.us

All questions received and the responses thereto will be mailed, emailed, or faxed to all prospective Responders by addendum. No inquiries except clarification of instructions will be addressed by telephone.

Responder is advised to carefully review this Request for Proposal – it provides specific information necessary to aid participating firms in formulating a thorough response. Responder's failure to examine all documents shall not entitle the Responder to any relief from the conditions imposing in the Request for Proposal and the resultant contract.

An authorized person from the Responder must sign the RFP. This signatory must be a person from the submitting firm who is duly authorized to tender and sign the RFP on behalf of the Responder and to bind the Responder to the terms and conditions of this Request for Proposal, the Responder's response, and all other terms and conditions of the contract. By this signature, the Responder further acknowledges that the Responder has read the Request for Proposal and RFP documents thoroughly before submitting a RFP and will fulfill the obligations in accordance with the terms, conditions, and specifications detailed herein.

5. RFP OPENING

The Purchasing Agent shall open the RFPs on the date and time specified herein. RFPs shall be opened in a manner that avoids disclosure of the contents to competing offerors and that keeps the Statements of Proposals secret during negotiations. The Purchasing Agent will examine Statements of Proposals promptly and thoroughly. Upon opening, no RFP may be withdrawn for a period of sixty (60) calendars days after the RFP opening date.

6. WITHDRAWAL OF RFP/FIRM RFP RULE

Responders may request withdrawal of their sealed RFP prior to the scheduled RFP opening time provided the request for withdrawal is submitted to the Purchasing Agent in writing. No Responses may be withdrawn for a period of sixty (60) calendar days after opening of the RFPs.

7. COMMISSIONERS' COURT

No contract is binding on the County until it is properly placed on the Commissioners' Court agenda, approved in open Court, authorized to be executed by the County Judge, and fully executed by both parties.

Department heads and elected officials are not authorized to enter into any type of agreement or contract on behalf of the County. Only the Commissioners' Court acting as a body may enter into a contract on behalf of and contractually bind the County. Additionally, department heads and elected officials are not authorized to agree to any type of supplemental agreements or contracts for goods or services. Supplemental agreements

GENERAL PROVISIONS

REQUEST FOR PROPOSALS MENTAL HEALTH COURT PUBLIC DEFENDER'S OFFICE BUILDOUT GALVESTON COUNTY, TEXAS

are subject to review by the County Legal Department prior to being accepted and signed by the County's authorized representative.

8. REJECTION OF RFP / DISQUALIFICATION

Galveston County, acting through its Commissioners' Court, reserves the right to:

- reject any and all Responses in whole or in part received by reason of this Request for Proposal;
- waive any informality in the Responses received;
- disregard the RFP of any Responder determined to be not responsible;
- disregard the RFP of any Responder determined to have not submitted its RFP timely; and/or
- discontinue its efforts for any reason under this Request for Proposal package at any time prior to actual execution of contract by the County.

Responders may be disqualified, and rejection of Statements of Proposals may be recommended to the Commissioners' Court for any of (but not limited to) the following causes:

- A. Failure to use the RFP forms furnished by the County, if applicable;
- B. Lack of signature by an authorized representative of Responder;
- C. Failure to properly complete the RFP;
- D. Engaging in communications regarding this procurement during the pendency of this procurement with County officials and/or personnel who are not within the Purchasing Department;
- E. Failure to meet the mandatory requirements of this Request for Proposal; and/or
- F. Evidence of collusion among Responders.

9. RESTRICTIVE OR AMBIGUOUS SPECIFICATIONS

It is the responsibility of the prospective Responder to review the entire Request for Proposal packet and to notify the Purchasing Agent if the specifications are formulated in a manner that would restrict competition or appear ambiguous. Any protest or question(s) regarding the specifications or RFP procedures must be received in the Purchasing Agent's Office not less than seventy-two (72) hours prior to the time set for RFP opening. Responders are to submit their RFP as specified herein or propose an approved equal.

10. SUBSTITUTES/DESCRIPTION OF MATERIALS AND EQUIPMENT

Any brand name or manufacturer reference used herein is intended to be descriptive and not restrictive, unless otherwise noted, and is used to indicate the type and quality of material. The term "or equal" if used, identifies commercially produced items that have the essential performance and salient characteristics of the brand name stated in the item description. All supplies, material, or equipment shall be new and of the most suitable grade for the purpose intended. For clarification, "new" includes products containing recovered materials that are EPA-designated items and additionally see Section 63 of these General Provisions on contracts involving federal funds. It is not the County's intent to discriminate against any materials or equipment of equal merit to those specified. However, if Responder desires to use any substitutions, prior written approval must be obtained from the Purchasing Agent and sufficiently in advance such that an addendum may be issued. All material supplied must be one hundred percent (100%) asbestos free. Responder, by submission of its RFP, certifies that if awarded any portion of this procurement, the Responder will supply only material and equipment that is 100% asbestos free.

GENERAL PROVISIONS

REQUEST FOR PROPOSALS MENTAL HEALTH COURT PUBLIC DEFENDER'S OFFICE BUILDOUT GALVESTON COUNTY, TEXAS

11. EXCEPTIONS TO RFP CONDITIONS

The Responder will list on a separate sheet of paper any exceptions to the conditions of this Request for Proposal. This sheet will be labeled, "Exceptions to RFP Conditions", and will be attached to the RFP. If no exceptions are stated, it will be understood that all applicable general and special conditions will be complied with, without exception.

The Responder must specify in its response, any alternatives it wishes to propose for consideration by the County. Each alternative should be sufficiently described and labeled within the response and should indicate its possible or actual advantage to the program being offered.

The County reserves the right to offer these alternatives to other Responders.

12. PRICING

Any requests for costs will be either lump sum or unit prices as shown on the RFP sheets if included. The net priced items will be delivered to Galveston County, including all freight, shipping, and delivery charges. Galveston County is a tax-exempt local government of the State of Texas, therefore, no taxes shall be included with submitted pricing.

Cash discounts must be shown on the sheets, otherwise prices will be considered net. Unless prices and all information requested are complete, the response may be disregarded and given no consideration.

In case of default by the contractor, the County of Galveston may procure the articles or services from other sources and may deduct from any monies due, or that may thereafter become due to the contractor, the difference between the price named in the contract of purchase order and the actual cost thereof to the County of Galveston. Prices paid by the County of Galveston shall be considered the prevailing market price at the time such purchase is made. Periods of performance may be extended if the facts as to the cause of delay justify such extension in the opinion of the Purchasing Agent and the Commissioners' Court.

13. PROCUREMENT CARD (P-CARD) PROGRAM

The County of Galveston participates in a Procurement Card (P-Card) program that allows payments made to a vendor by credit card. This method typically results in substantially faster bill payments, sometimes within three (3) to five (5) days of the actual transaction date. All transaction fees from the card provider are to be paid by the successful contractor. If awarded company will accept payment via credit card (Visa, MasterCard, etc.), this should be notated in the RFP submittal.

14. PASS THROUGH COST ADJUSTMENTS

Except in instances of extreme extenuating circumstances, Contractor prices shall remain firm throughout the contract period and any renewals. Examples of extreme extenuating circumstances include such situations as a nationwide rail strike, oil shortage or oil embargo.

In extreme extenuating circumstances, Contractors may be allowed to temporarily "pass through" additional costs they are forced to incur through no fault of their own. A request for a pass-through cost increase will not be considered unless a Contractor's cost for the Contractor's product exceeds 10% over the original cost for the product. Also, the increase in cost must be nationwide and consistent for a minimum period of sixty (60) calendar days. Costs that historically are anticipated to rise over a period of time (for example only, such as wages or insurance costs) do not qualify for pass through.

GENERAL PROVISIONS

REQUEST FOR PROPOSALS MENTAL HEALTH COURT PUBLIC DEFENDER'S OFFICE BUILDOUT GALVESTON COUNTY, TEXAS

If a Contractor thinks he will be asking for a pass-through cost adjustment during the term of the contract, then the original cost of the product to Contractor must be stated in Contractor's original response.

A request for a pass-through cost does not guarantee that one will be granted. Contractors must submit such information on each request as required by the County Purchasing Agent. The County Purchasing Agent will review each request on a case-by-case basis and if valid, submit the request to the Commissioners' Court for authorization and determination of the appropriateness of each request as well as amount and duration of increase. Contractors will not be permitted any additional compensation for mark-ups or profits based on the increase in price. Rather, such additional compensation will be limited to the actual increase in original cost to the Contractor as such increase is reflected by the original cost stated in the RFP. But in no event will the amount of additional compensation exceed 25% increase in Contractor's original cost for the product as such cost is reflected in Contractor's original solicitation or the duration exceed a period of sixty (60) calendar days. In addition, should the cost, during the period of the pass through, return to normal or decrease to below pre pass through prices, appropriate downward adjustments shall be made. No more than one pass through adjustment will be permitted per year.

15. MODIFICATION OF STATEMENTS OF PROPOSALS

A Responder may modify a response by letter at any time prior to the submission deadline for receipt of Statements of Proposals. Modification requests must be received by the Purchasing Agent prior to the submission deadline. Modifications made before opening time must be initialed by Responder guaranteeing authenticity. Statements of Proposals may not be amended or altered after the official opening with the single exception that any product literature and/or supporting data required by the actual specifications, if any, will be accepted at any time prior to the Commissioners' Court considering of same.

16. PRE-PROPOSAL CONFERENCE

A pre-proposal conference for the purpose of discussing contract requirements and answering questions of prospective Responders may be conducted in this procurement. A pre-proposal conference may be mandatory or voluntary. If the pre-proposal conference is mandatory, then the County is authorized to condition acceptance of a RFP on compliance with attendance. The Special Provisions of this procurement shall specify if a pre-proposal conference is to be held and shall specify whether the pre-proposal conference is mandatory or voluntary. Regardless of whether the pre-proposal conference is mandatory or voluntary, only a principal, officer, or employee of the Responder may represent the Responder at the pre-proposal conference, and no person may represent more than one Responder at the pre-proposal conference.

17. SIGNATURE OF RFP

Each Statement of Qualification shall give the complete name of the Responder and the mailing address of the Responder and be signed by an authorized representative by original signature with the authorized representative's name and legal title typed below the signature line. Each RFP shall include the Responder's Federal Employer Identification Number (FEIN). Failure to sign the Contract page(s) and RFP response sheets may disqualify the RFP from being considered by the County. The person signing on behalf of the Responder expressly affirms that the person is duly authorized to tender the RFP on behalf of the Responder and to sign the RFP sheets and contract under the terms and conditions of this Request for Proposal and to bind the Responder hereto and further understands that the signing of the contract shall be

GENERAL PROVISIONS

REQUEST FOR PROPOSALS MENTAL HEALTH COURT PUBLIC DEFENDER'S OFFICE BUILDOUT GALVESTON COUNTY, TEXAS

of no effect until it is properly placed on the Commissioners' Court agenda, approved in open Court, authorized to be executed by the County Judge, and fully executed by both parties.

18. AWARD OF RFP – EVALUATION CRITERIA AND FACTORS

The award will be made to the responsible Responder whose Statement of Qualification is determined to be the lowest and best evaluated offer demonstrating the best ability to fulfill the requirements set forth in this Request for Proposal. **Any proposed costs to the County will be considered firm and cannot be altered after the submission deadline, unless the County invokes its right to request a best and final offer.**

"Lowest and best" means an RFP or offer providing the best value considering associated direct and indirect costs, including transport, maintenance, reliability, life cycle, warranties, and customer service after a sale.

In determining the lowest and best submittal for a contract for the purchase of earth-moving, material-handling, road maintenance, or construction equipment, the Commissioners' Court may also consider the information submitted under Section 262.0255 of the Local Government Code; and in determining the lowest and best response for a contract for the purchase of road construction material, the Commissioners' Court may consider the pickup and delivery locations of the Responders and the cost to the county of delivering or hauling the material to be purchased. The Commissioners' Court may award contracts for the purchase of road construction material to more than one Responder if each of the selected Responders submits the lowest and best response for a particular location or type of material.

Each Responder, by submitting a response, agrees that if its' response is accepted by the Commissioners' Court, the Responder will furnish all items and services upon which prices have been tendered and upon the terms and conditions in this solicitation, including but not limited to the best and final offer if applicable, and the contract.

The contractor shall commence work only after the transmittal of a fully executed contract and after receiving written notification to proceed from the County Purchasing Agent. The contractor will perform all services indicated in the solicitation in compliance with this contract.

Neither department heads nor elected officials are authorized to sign any binding contracts or agreements prior to being properly placed on the Commissioners' Court agenda and approved in open court. Department heads and other elected officials are not authorized to enter into any type of agreement or contract on behalf of Galveston County. Only the Commissioners' Court, acting as a body, may enter into a contract on behalf of the County. Additionally, department heads and other elected officials are not authorized to agree to any type of supplemental agreements or contracts for goods or services. Supplemental agreements are subject to review by the County's legal counsel prior to being signed by the County's authorized representatives.

The County of Galveston reserves the right to accept Statements of Proposals on individual items listed, or group items, or on the RFP as a whole; to reject any and all RFPs; to waive any informality in the RFPs; to disregard Responses that are not submitted timely; to disregard the Responses of Responders determined to be not responsible; and to accept the response that appears to be in the best interest of the County. The selection process may, however, include a request for additional information or an oral presentation to support the written RFP.

GENERAL PROVISIONS

REQUEST FOR PROPOSALS MENTAL HEALTH COURT PUBLIC DEFENDER'S OFFICE BUILDOUT GALVESTON COUNTY, TEXAS

In determining and evaluating the best RFP, the pricing component may not necessarily be controlling, but quality, equality, efficiency, utility, general terms, delivery, suitability of the service offered, and the reputation of the service in general use will also be considered along with any other relevant items.

The County reserves the right to reject any or all Responses in whole or in part received by reason of this Request for Proposal and may discontinue its efforts under this Request for Proposal for any reason or no reason or solely for the County's convenience at any time prior to actual execution of the contract by the County.

A Responder whose response does not meet the mandatory requirements set forth in this Request for Proposal will be considered non-compliant.

The invitation to submit a response which appears in the newspaper, or other authorized advertising mediums, these general provisions, the special specifications which follow, the RFP sheets, forms, and any addenda issued are all considered part of the RFP and resultant contract.

Each Responder, by submitting a response, agrees that if its response is accepted by the Commissioners' Court, such Responder will furnish all items and services upon the terms and conditions in this Request for Proposal and the resultant contract.

Notice of contract award is anticipated to be made within ninety (90) days of opening of RFPs to the lowest responsive and responsible contractor, who's response complies with all the requirements in the Request for Proposal.

Contractor shall submit to the County, for approval, within ten (10) days from notice of contract award, all Certificates of Insurance evidencing the required coverage as described under Section 37, Requirement of and Proof of Insurance, or if different, then as described within the Special Provisions or resultant contract.

The contractor shall not commence work under these terms and conditions of the contract until all applicable Purchase Orders, Certificates of Insurance, Performance and Payment Bonds, and Irrevocable Letters of Credit (if required) have been approved by the County of Galveston and the Contractor has received notice to proceed in writing and an executed copy of the contract from the County Purchasing Agent.

19. DISPUTE AFTER AWARD/PROTEST

Any actual or prospective Responder who is allegedly aggrieved in connection with this procurement or award of a contract resulting therefrom may protest. The protest shall be submitted in writing to the Purchasing Agent within seven (7) calendar days after such aggrieved person knows of or should have known of the facts giving rise thereto. If the protest is not resolved by mutual agreement, the Purchasing Agent will promptly issue a decision in writing to the protestant. If the protestant wishes to appeal the decision rendered by the Purchasing Agent, such appeal must be made to the Commissioners' Court through the Purchasing Agent. The decision of the Commissioners' Court will be final. The Commissioners' Court need not consider protests unless this procedure is followed.

GENERAL PROVISIONS

REQUEST FOR PROPOSALS MENTAL HEALTH COURT PUBLIC DEFENDER'S OFFICE BUILDOUT GALVESTON COUNTY, TEXAS

20. PUBLIC INFORMATION ACT (f/k/a Open Records Act)

The Responder acknowledges that the County is a government body for purposes of the Public Information Act, codified as Chapter 552 of the Texas Government Code, and as such is required to release information in accordance with the provisions of the Public Information Act.

If Responder considers any of its submitted information to be proprietary in nature, trade secret, or otherwise confidential, then it must clearly and conspicuously mark such information as proprietary, trade, secret, or confidential. By the submission of its response, Responder expressly affirms that it has clearly and conspicuously marked any information within its submission that Responder considers confidential, proprietary, and/or trade secret.

In the event the County receives a request for information under the Public Information Act seeking information that the Responder has marked as confidential, proprietary, and /or trade secret, then the County agrees that it shall provide notice to the Responder of the request for information and the request for decision process under the Public Information Act. Thus, the County will submit the initial correspondence to the Texas Attorney General – however, the burden is and shall be on the Responder to submit correspondence to the Attorney General if the Responder wishes its information to be withheld. Responder is deemed to have knowledge of the Public Information Act.

By the submission of its response, Responder expressly acknowledges that the burden to withhold its' information from public disclosure lays with the Responder; thus, Responder further acknowledges and agrees that it shall submit comments to the Texas Attorney General in the request for decision process if Responder wishes to have its' information withheld from public disclosure.

21. RESPONDER'S E-MAIL ADDRESSES – CONSENT TO DISCLOSURE

Notwithstanding the foregoing Section 20, Responder acknowledges and agrees that the confidentiality of any and all email addresses Responder uses or discloses in communicating with the County are **open** to the public in accordance with Section 552.137 of the Government Code and Responder consents to the release of its email addresses.

22. RESULTANT CONTRACT

Responder shall correctly and fully execute the resultant contract first. After this, the contract shall be set for consideration by the Commissioners' Court. If the Commissioners' Court authorizes the execution of the contract, the resultant contract shall become effective upon the Commissioners' Court execution of same, provided that the contract is executed by all parties to the contract. Contract documents shall consist of the contract, the General and Special Provisions, drawings, RFP package (including best and final offer(s) if such is utilized), any addenda issued, and any change orders issued during the work. If applicable to the attached RFP, Responder must sign three (3) original contracts and return all three with their RFP submittal.

Responder should submit a proposed contract with its Statement of Qualification, or its sample material terms and conditions for review and consideration.

GENERAL PROVISIONS

REQUEST FOR PROPOSALS MENTAL HEALTH COURT PUBLIC DEFENDER'S OFFICE BUILDOUT GALVESTON COUNTY, TEXAS

23. CONTRACT TERM

The term of the resultant contract will begin on the date of full execution or the execution by the Commissioners' Court, whichever is later, and will terminate on the date specified in the resultant contract unless terminated earlier as herein set forth.

24. TERMINATION FOR DEFAULT

Failure of either party in the performance of any of the provisions of this contract shall constitute a breach of contract, in which case either party may require corrective action within ten (10) business days from date of receipt of written notice citing the exact nature of such breach. Failure of the party being notified to take corrective action within the prescribed ten (10) business days, or failure to provide written reply of why no breach has occurred, shall constitute a Default of Contract.

All notices relating to default by Responder of the provisions of the contract shall be issued by the County through its Legal Department, and all replies shall be made in writing to the County Legal Department. Notices issued by or issued to anyone other than the County Legal Department shall be null and void and shall be considered as not having been issued or received.

Galveston County reserves the right to enforce the performance of this contract in any manner prescribed by law in the event of breach or default of this contract, and may contract with another party, with or without solicitation of RFPs or further negotiations. At a minimum, Responder shall be required to pay any difference in service or materials, should it become necessary to contract with another source, plus reasonable administrative costs and attorney fees.

In the event of Termination for Default, Galveston County, its agents, or representatives shall not be liable for loss of any profits anticipated to be made by Responder.

In addition to the remedies stated herein, the County has the right to pursue other remedies permitted by law or in equity.

No waiver by either party of any event of default under this agreement shall operate as a waiver of any subsequent default under the terms of this agreement.

County reserves the right to terminate this contract immediately in the event Responder:

- A. Fails to meet delivery or completion schedules; and/or
- B. Fails to otherwise perform in accordance with the accepted RFP and the contract.

25. TERMINATION FOR CONVENIENCE

County may terminate this contract upon at least thirty (30) calendar days prior written notice for its convenience or for any reason deemed by the County to serve the public interest. As well, County may terminate this contract upon thirty (30) calendar days prior written notice for any reason resulting from any governmental law, order, ordinance, regulation, or court order. In no event shall County be liable for loss of any profits anticipated to be made hereunder by Responder should this contract be terminated early.

GENERAL PROVISIONS

REQUEST FOR PROPOSALS MENTAL HEALTH COURT PUBLIC DEFENDER'S OFFICE BUILDOUT GALVESTON COUNTY, TEXAS

26. FORCE MAJEURE

If by reason of Force Majeure either Party shall be rendered unable, wholly or in part, to carry out its responsibilities under this contract by any occurrence by reason of Force Majeure, then the Party unable to carry out its responsibility shall give the other Party notice and full particulars of such Force Majeure in writing within a reasonable time after the occurrence of the event, and such notice shall suspend the Party's responsibility for the continuance of the Force Majeure claimed, but for no longer period.

Force Majeure means acts of God, floods, hurricanes, tropical storms, tornadoes, earthquakes, or other natural disasters, acts of a public enemy, acts of terrorism, sovereign conduct, riots, civil commotion, strikes or lockouts, and other causes that are not occasioned by either Party's conduct which by the exercise of due diligence the Party is unable to overcome, and which substantially interferes with operations.

27. ESTIMATED QUANTITIES

Any reference to quantities shown in the Request for Proposal is an estimate only. Since the exact quantities cannot be predetermined, the County reserves the right to adjust quantities as deemed necessary to meet its requirements.

28. CONTRACTOR INVESTIGATION

Before submitting a Statement of Qualification, each Responder shall make all investigations and examinations necessary to ascertain all site conditions and requirements affecting the full performance of the contract and to verify any representations made by the County upon which the contractor will rely. Responder shall exercise due diligence and is further charged with knowledge of the local, State, and Federal laws, rules, and regulations applicable to this contract. If the Responder receives an award as a result of its RFP submission in this procurement, the Responder's failure to have made such investigations and examinations will in no way relieve the Responder from its obligation to comply in every detail with all provisions and requirements of the contract, nor will a plea of ignorance of such conditions and requirements be accepted as a basis for any claim whatsoever by the contractor for additional compensation and/or for excused nonperformance.

29. NO COMMITMENT BY COUNTY OF GALVESTON

This request for procurement does not commit the County of Galveston to award any costs or pay any costs, or to award any contract, or to pay any costs associated with or incurred in the preparation of an RFP in response to this Request for Proposal and does not commit the County of Galveston to procure or contract for services or supplies.

30. RFP COSTS BORNE BY RESPONDER

Galveston County shall not be liable for any costs incurred by Responder in preparation, production, or submission of an RFP, including but not limited to best and final offer if applicable. As well, Galveston County shall not be liable for any work performed by Responder prior to issuance of fully executed contract and properly issued notice to proceed and/or Purchase Order. Galveston County shall not be liable for any costs incurred by Responder by reason of attending a pre-RFP conference. Galveston County shall not be liable for any costs incurred by Responder by reason of the County invoking use of best and final offers.

GENERAL PROVISIONS

REQUEST FOR PROPOSALS MENTAL HEALTH COURT PUBLIC DEFENDER'S OFFICE BUILDOUT GALVESTON COUNTY, TEXAS

31. BEST AND FINAL OFFERS (BAFO)

In acceptance of Statements of Proposals, the County reserves the right to negotiate further with one or more of the Responders as to any features of their Statements of Proposals and to accept modifications of the work and price when such action will be in the best interest of the County. This includes, but is not limited to, the solicitation of a Best and Final Offer from one or more of the Responders. If a Best and Final Offer is invoked, this allows acceptable Responders the opportunity to amend, change, or supplement their original response. Responders may be contacted in writing by the Purchasing Agent, requesting that they submit their Best and Final Offer. Any such Best and Final Offer must include discussed and negotiated changes.

32. SINGLE RFP RESPONSE

If only one Statement of Qualification is received in response to the Request for Proposal, a detailed cost response may be requested of the single Responder. A cost/price analysis and evaluation and/or audit may be performed of the cost proposal to determine if the price is fair and reasonable.

33. CHANGES IN SPECIFICATIONS

If it becomes necessary to revise any part of this RFP, a written notice of such revision will be provided to all Responders in the form of addenda. The County is not bound by any oral representations, clarifications, or changes made in the written specifications by the County's employees or officials, unless such clarification or change is provided to Responders in a written addendum from the Purchasing Agent. Responders are advised to inquire prior to the submission deadline as to whether any addenda to this Request for Proposal have been issued, as the successful Responder will be required to abide by such addenda.

The County of Galveston reserves the right to revise or amend the specifications up to the time set for opening of RFPs. Such revisions and amendments, if any, shall be announced by form of addenda. Copies of such addenda (or addendum in the event only one addendum is issued in the procurement) shall be furnished to all prospective contractors. Prospective contractors are defined as those contractors listed on the County's Request for Proposal list for this material/service or those who have obtained documents from the Purchasing Agent's Office subsequent to the advertisement. If revisions and amendments require changes in quantities or prices proposed, or both, the date set for opening of RFPs may be postponed by such number of days as in the opinion of the County shall enable prospective contractors to revise their responses. In any case, the RFP opening shall be at least seven (7) business days after the last revising or amendment addendum and the addendum shall include an announcement of the new date, if applicable, for the opening of RFPs.

34. RFP IDEAS AND CONCEPTS

The County reserves to itself the right to adopt or use for its benefit, any concept, plan, or idea contained in any RFP.

35. RFP DISCLOSURES

While this procurement is pending, the names of those who submitted Statements of Proposals will not be made public unless in conformity with the County Purchasing Act. Likewise, no pricing, staffing, or other contents of the RFP information will be released unless in conformity with the County Purchasing Act. Responders are requested to withhold all inquiries regarding their RFP or other submissions until after an

GENERAL PROVISIONS

REQUEST FOR PROPOSALS MENTAL HEALTH COURT PUBLIC DEFENDER'S OFFICE BUILDOUT GALVESTON COUNTY, TEXAS

award is made. No communication is to be had with any County employee or official, other than the County Purchasing Agent, regarding whether a RFP was received. Violations of this provision may result in the rejection of an RFP.

36. INDEMNIFICATION

The contractor agrees to assume all risks and responsibility for, and agrees to indemnify, defend, and save harmless, the County of Galveston, its elected and appointed officials and department heads, and its agents and employees from and against all claims, demands, suits, actions, recoveries, judgments, and costs and expenses including reasonable attorney's fees for the defense thereof, arising out of or in connection therewith on account of the loss of life, property or injury or damage to the person which shall arise from contractor's operations under this contract, its use of County facilities and/or equipment or from any other breach on the part of the contractor, its employees, agents or any person(s), in or about the County's facilities with the expressed or implied consent of the County. Contractor shall pay any judgment with cost which may be obtained against Galveston County resulting from contractor's operations under this contract.

Contractor agrees to indemnify and hold the County harmless from all claims of subcontractors, laborers incurred in the performance of this contract. Contractor shall furnish satisfactory evidence that all obligations of this nature herein above designated have been paid, discharged or waived. If Contractor fails to do so, then the County reserves the right to pay unpaid bills of which County has written notice direct and withhold from Contractor's unpaid compensation a sum of money reasonably sufficient to liquidate any and all such lawful claims.

37. REQUIREMENT OF AND PROOF OF INSURANCE

The successful Responder shall furnish evidence of insurance to the County Purchasing Agent and shall maintain such insurance as required hereunder or as may be required in the Special Provisions or resultant contract, if different. Contractor shall obtain and thereafter continuously maintain in full force and effect, Commercial General Liability insurance, including but not limited to bodily injury, property damage, and contractual liability, with combined single limits as listed below or as may be required by State or Federal law, whichever is greater.

- A. For damages arising out of bodily injury to or death of one person in any one accident:
ONE HUNDRED THOUSAND AND NO/100 (\$100,000.00) DOLLARS.
- B. For damages arising out of bodily injury to or death of two or more persons in any one accident:
THREE HUNDRED THOUSAND AND NO/100 (\$300,000.00) DOLLARS.
- C. For any injury to or destruction of property in any one accident:
ONE HUNDRED THOUSAND AND NO/100 (\$100,000.00) DOLLARS.

Insurance shall be placed with insurers having an A.M. Best's rating of no less than A. Such insurance must be issued by a casualty company authorized to do business in the State of Texas, and in standard form approved by the Board of Insurance Commissioners of the State of Texas, with coverage provisions ensuring the public from loss or damage that may arise to any person or property by reason of services rendered by Contractor.

GENERAL PROVISIONS

REQUEST FOR PROPOSALS MENTAL HEALTH COURT PUBLIC DEFENDER'S OFFICE BUILDOUT GALVESTON COUNTY, TEXAS

Galveston County shall be listed as the additional insured on policy certificates and shall be provided with no less than thirty (30) calendar days prior notice of any changes to the policy during the contractual period.

Certificates of Insurance, fully executed by a licensed representative of the insurance company written or countersigned by an authorized Texas state agency, shall be filed with the County Purchasing Agent within ten (10) business days of issuance of notification from the County Purchasing Agent to Responder that the contract is being activated as written proof of such insurance and further provided that Responder shall not commence work under this contract until it has obtained all insurance required herein, provided written proof as required herein, and received written notice to proceed issued from the County Purchasing Agent.

Proof of renewal/replacement coverage shall be provided prior to the expiration, termination, or cancellation date of any policy and Galveston County shall be named as an additional insured on any such renewal/replacement coverage and a certificate of insurance showing such shall be provided to the Purchasing Agent. Said insurance shall not be cancelled, permitted to expire, or changed without at least thirty (30) days prior written notice to the County.

Insurance required herein shall be maintained in full force and effect during the life of this contract and shall be issued on an occurrence basis. Contractor shall require that any and all subcontractors that are not protected under the Contractor's own insurance policies take and maintain insurance of the same nature and in the same amounts as required of Contractor and provide written proof of such insurance to Contractor. Proof of renewed/replacement coverage shall be provided prior to the expiration, termination, or cancellation date of any policy. Contractor shall not allow any subcontractor to commence work on the subcontract until such insurance required for the subcontractor has been obtained and approved.

Workers' Compensation Insurance: Successful Responder shall carry in full force Workers' Compensation Insurance Policy(ies), if there is more than one employee, for all its' employees, including but not limited to full time, part time, and emergency employees employed by the successful Responder. Current insurance certificates certifying that such policies as specified above are in full force and effect shall be furnished by successful Responder to the County.

Insurance is to be placed with insurers having a Best rating of no less than A. The Responder shall furnish the County with certificates of insurance and original endorsements affecting coverage required by these insurance clauses within ten (10) business days of receiving notification from the County Purchasing Agent that the contract is being activated. The certificates and endorsements for each insurance policy are to be signed by a person authorized by the insurer to bind coverage on its behalf. The Responder shall be required to submit annual renewals for the term of this contract prior to expiration of any policy.

In addition to the remedies stated herein, the County has the right to pursue other remedies permitted by law or in equity.

The County agrees to provide Responder with reasonable and timely notice of any claim, demand, or cause of action made or brought against the County arising out of or related to utilization of the property. Responder shall have the right to defend any such claim, demand, or cause of action at its sole cost and expense and within its sole and exclusive discretion. The County agrees not to compromise or settle any claim or cause of action arising out of or related to the utilization of the property without the prior written consent of the Responder.

In no event shall the County be liable for any damage to or destruction of any property belonging to the Responder.

GENERAL PROVISIONS

REQUEST FOR PROPOSALS MENTAL HEALTH COURT PUBLIC DEFENDER'S OFFICE BUILDOUT GALVESTON COUNTY, TEXAS

Subrogation Waiver. Responder and Responder's insurance carrier waive any and all rights to subrogation against Galveston County in regard to any suit or claim arising out of personal injury or property damage resulting from Responder's performance under this agreement.

38. RFP GUARANTEE (if required)

Unless specified differently within the Special Provisions of this procurement, each Responder shall be required to submit a RFP guarantee with its RFP as required within this Section.

Evidencing its firm commitment to engage in contract if Responder is selected for award of contract, each Responder is required to furnish with their RFP a cashier's check or an acceptable Responder's bond (generally, a RFP bond) in the amount of five percent (5%) of the total contract price. If Responder is using a bond, then the bond must be executed with a surety company authorized to do business in the State of Texas. Failure to furnish the RFP guarantee in the proper form and amount, by the time set for opening of RFPs may be cause for rejection of the RFP.

The cashier's check or Responder bond (as applicable) will be returned to each respective unsuccessful Responder(s) after the Commissioners' Court award of contract and shall be returned to the successful Responder upon the completion and submission of all contract documents. Provided however, that the cashier's check or Responder bond will be forfeited to the County as liquidated damages should successful Responder fail to execute the contract within thirty (30) days after receiving notice of the acceptance of its RFP.

39. PERFORMANCE AND PAYMENT BONDS (if required)

Successful Responder, before beginning work, shall execute a performance bond and a payment bond, each of which must be in the amount of the contract. The required payment and performance bonds must each be executed by a corporate surety authorized to write surety bonds in the State of Texas and in accordance with Chapter 3503 of the Insurance Code (codified in 2005 and originally within Section 1, Chapter 87, Acts of the 56th Leg., R.S., 1959, and in Article 7.19-1, Vernon's Texas Insurance Code).

The performance and payment bonds must each clearly and prominently display on the bond or on an attachment to the bond:

- a.) The name, mailing address, physical address, and telephone number, including the area code, of the surety company to which any notice of claim should be sent; or
- b.) The toll-free telephone number maintained by the Texas Department of Insurance under Subchapter B, Chapter 521, Insurance Code, and a statement that the address of the surety company to which any notice of claim should be sent may be obtained from the Texas Department of Insurance by calling the toll free-telephone number.

The performance bond shall be solely for the protection of Galveston County, in the full amount of the contract, and conditioned on the faithful performance of the work in accordance with the plans, specifications, and contract documents. The payment bond is solely for the protection and use of payment bond beneficiaries who have a direct contractual relationship with the prime contractor or a subcontractor to supply labor or material, and in the amount of the contract.

GENERAL PROVISIONS

REQUEST FOR PROPOSALS MENTAL HEALTH COURT PUBLIC DEFENDER'S OFFICE BUILDOUT GALVESTON COUNTY, TEXAS

The payment and performance bonds required to be furnished herein must be furnished before the contractor begins work and are a requirement for issuance of a Notice to Proceed. Such bonds must be furnished to the Galveston County Purchasing Agent within thirty (30) calendar days after the date of the full execution of the contract or, if applicable, as required under Chapter 2253, Government Code, whichever is earlier. Contractor's failure to provide the required payment and performance bonds within such time period shall constitute an event of default under this contract. Contractor shall not commence work until all applicable certificates of insurance, performance bonds, and payment bonds have been received and approved by the County Purchasing Agent and the Contractor receives notice to proceed in writing that has been issued by the County Purchasing Agent.

Additionally, if this Request for Proposal is for the award of a public works contract, then compliance with Chapter 2253 of the Texas Government Code, which is known as the McGregor Act, is mandatory. Performance and payment bonds are required to be furnished in accordance with Chapter 2253 of the Texas Government Code. Responder should familiarize itself with the entire provisions of Chapter 2253 of the Texas Government Code.

40. PATENT AND COPYRIGHT PROTECTION

The Responder agrees at its sole expense to protect the County from claims involving infringement of patents, copyright, trademark, trade secret, or other intellectual property rights. **Responder shall indemnify and save harmless the County of Galveston, its officers, employees, and agents, from liability of any nature and kind whatsoever, including without limitation cost and expenses, for or on account of any copyrighted, trademarked, trade secret, patented or un-patented invention, process, or article manufactured or used in the performance of the contract, or other intellectual property rights, including its use by the County.** Responder also agrees that if Responder is awarded this contract, that no work performed hereunder shall be subject to patent, copyright, or other intellectual property by Responder.

41. CONFLICT OF INTEREST DISCLOSURE REPORTING (FORM CIQ)

Responder may be required under Chapter 176 of the Texas Local Government Code to complete and file a Conflict-of-Interest Questionnaire (CIQ Form). The CIQ Form pertains to business relationship, gift giving and family relationship reporting. If Responder is required to file a CIQ Form, then **the completed CIQ Form must be filed with the County Clerk of Galveston County, Texas.**

Business relationship. If Responder has an employment or other business relationship with a local government officer of Galveston County or with a family member of a local government officer of Galveston County that results in the officer or family member of the officer receiving taxable income that exceeds \$2,500.00 during the preceding 12-month period, then Responder **MUST** complete a CIQ Form and file the original of the CIQ Form with the County Clerk of Galveston County.

Gift-giving. If Responder has given a local government officer of Galveston County or a family member of a local government officer of Galveston County one or more gifts with an aggregate value of more than one-hundred dollars (\$100.00) during the preceding 12-months, then Responder **MUST** complete a CIQ Form and file the original of the CIQ Form with the County Clerk of Galveston County.

Family member. For purposes of the business relationship and gift giving reporting requirements, a "family member" means a person related to another person with the first degree of consanguinity or affinity, as described by Subchapter B, Chapter 573, Texas Government Code. Examples of persons within the first

GENERAL PROVISIONS

REQUEST FOR PROPOSALS MENTAL HEALTH COURT PUBLIC DEFENDER'S OFFICE BUILDOUT GALVESTON COUNTY, TEXAS

degree by consanguinity or affinity include a son, daughter, father, mother, spouse, son-in-law, daughter-in-law, father-in-law, mother-in-law, stepson, stepdaughter, stepmother, and stepfather.

Family relationship. If Responder has a "family relationship" with a local government officer of Galveston County then Responder **MUST** complete a CIQ Form and file the original of the CIQ Form with the County Clerk of Galveston County, regardless of whether Responder has a business relationship or has given gifts to the local government officer or a family member of the local government officer. For this purpose, "family relationship" means Responder is related within the third degree by consanguinity or the second degree by affinity, as those terms are defined under Chapter 573 of the Texas Government Code, to a local government officer of Galveston County. Examples of such relationships include a son, daughter, mother, father, brother, sister, grandchild, great-grandchild, grandparent, great-grandparent, niece, nephew, uncle, aunt, spouse, mother-in-law, father-in-law, daughter-in-law, son-in-law, spouse's grandchild, spouse's grandparent, grandparent's spouse, grandchild's spouse, stepson, stepdaughter, stepmother, and stepfather.

Responder must file its original CIQ Form with the Galveston County Clerk. The Galveston County Clerk has offices at the following locations:

Galveston County Clerk
Galveston County Justice Center, Suite 2001
600 59th Street
Galveston, Texas 77551

Galveston County Clerk
North County Annex, 1st Floor
174 Calder Road
League City, Texas 77573

Again, if Responder is required to file a CIQ Form, the original completed form is filed with the Galveston County Clerk (**not the Purchasing Agent**).

For Responder's convenience, a blank CIQ Form is enclosed with this RFP package. Blank CIQ Form(s) may also be obtained by visiting the Purchasing Agent's website. This website is linked from the Galveston County homepage, at <http://www.galvestoncountytexas.gov>.

Chapter 176 specifies deadlines for the filing of CIQ Forms (both initial filings and updated filings).

It is Responder's sole responsibility to file a true and complete CIQ Form with the Galveston County Clerk if Responder is required to file by the requirements of Chapter 176 of the Local Government Code. Responder is advised that it is an offense to fail to comply with the disclosure reporting requirements dictated under Chapter 176 of the Texas Local Government Code, and the failure to file may be grounds to void the contract, if Responder is awarded a contract.

If Responder has any questions about compliance with Chapter 176, Responder may wish to consult its' legal counsel. Compliance is the individual responsibility of each person, business, and agent who is subject to Chapter 176 of the Texas Local Government Code.

42. DISCLOSURE OF INTERESTED PARTIES/FORM 1295

GENERAL PROVISIONS

REQUEST FOR PROPOSALS MENTAL HEALTH COURT PUBLIC DEFENDER'S OFFICE BUILDOUT GALVESTON COUNTY, TEXAS

Under Section 2252.908 of the Government Code, any business entity that enters into a contract with Galveston County that requires the approval of the Commissioners' Court must submit a "Disclosure of Interested Parties" to the County prior to the execution of the contract. This form, the "Disclosure of Interested Parties" form was promulgated by the Texas Ethics Commission and is the "Form 1295". **This procurement is subject to these requirements.**

The Texas Ethics Commission was charged with promulgating rules to implement Section 2252.908 of the Government Code. The rules adopted by the Texas Ethics Commission are located at Sections 46.1, 46.3, and 46.5 of Title 1 of the Texas Administrative Code. Thus, the law covering these requirements is located at Section 2252.908 of the Government Code, and in Title 1, Sections 46.1, 46.3, and 46.5 of the Texas Administrative Code.

The Texas Ethics Commission's website is: www.ethics.state.tx.us. The area of the Texas Ethics Commission website pertaining to Form 1295 is:

www.ethics.state.tx.us/whatsnew/elf_info_form1295.htm.

Form 1295 must be completed electronically through the Texas Ethics Commission website (handwritten forms are not allowable). Once the business entity has completed their electronic filing of Form 1295, then the business entity must print out the electronically completed form, and sign and notarize the Form 1295. Once Form 1295 is signed and notarized, the business entity must submit their completed, signed, and notarized Form 1295 to the Galveston County Purchasing Agent.

Successful Responder is and shall be subject to these requirements, and no resultant contract may be executed by the Commissioners' Court until the completed, signed, and notarized Form 1295 is on file with the County Purchasing Agent.

No portion of the Form 1295 process commits the County to any type of award of contract whatsoever.

After the Purchasing Agent's Office receives the completed, signed, and notarized Form 1295, the Purchasing Department representative will, within 30 days, go to the Texas Ethics Commission website to submit electronic confirmation of the County's receipt of the completed, signed, and notarized Form 1295.

43. CERTIFICATION REGARDING DEBARMENT, SUSPENSION, PROPOSED DEBARMENT, AND OTHER RESPONSIBILITY MATTERS & REQUIREMENT TO REGISTER IN SAM

Responder certifies that neither it, nor any of its Principals, are presently debarred, suspended, proposed for debarment, disqualified, excluded, or in any way declared ineligible for the award of contracts by any Federal agency. Contractor agrees that it shall refund Galveston County for any payments made to Contractor while ineligible. Contractor acknowledges that Contractor's uncured failure to perform under this Agreement, if such should occur, may result in Contractor being debarred from performing additional work for the County, the respecting State Agency administering the grant funding the contract, if applicable, the State, FEMA, or HUD (as applicable), and other Federal and State entities. Further, Responder has executed the Certification Regarding Debarment, Suspension, Proposed Debarment, and Other Responsibility Matters and returned the fully completed and executed original certification with the submission of its Statement of Qualification.

The truthful and fully completed and executed original of the Certification Regarding Debarment, Suspension, Proposed Debarment, and Other Responsibility Matters must be included with the submission of Responder's Statement of Qualification and is a mandatory requirement of this Request for Proposal. Responder's failure to include the fully completed and executed original of this

GENERAL PROVISIONS

REQUEST FOR PROPOSALS MENTAL HEALTH COURT PUBLIC DEFENDER'S OFFICE BUILDOUT GALVESTON COUNTY, TEXAS

Certification shall be considered non-compliance with the requirements of this Request for Proposal and grounds for the rejection of Responder's RFP.

Responder shall immediately notify the County Purchasing Agent if it becomes debarred or suspended, placed on the Consolidated List of Debarred Contractors, or in any other way becomes ineligible for award of contract by any Federal agency. This Certification is a material fact relied upon by Galveston County; if it is later determined that the contractor did not comply with 2 C.F.R. Part 180 and 2 C.F.R. Part 3000, in addition to the remedies available to Galveston County and the State agency administering this grant, the Federal Government may pursue available remedies, including but not limited to suspension and/or debarment of contractor.

If the contract to be awarded pursuant to this procurement involves the use of Federal funds, then Responder must also be registered in the Federal Contractor Registry through the System for Award Management (SAM) to be eligible for award of contract pursuant to this procurement.

Information regarding the SAM is available at:

<http://www.federalcontractorregistry.com/?gclid=CIG1hf2rr8wCFYkCaQoducANZw> or at
<https://www.sam.gov/portal/SAM/#1>.

No contract involving the use of Federal funds may be awarded to any Responder unless and until such registration is current and in good standing under SAM. Successful Responder must maintain SAM registration throughout the entire term of the agreement with the County. If this contract involves the use of Federal funds, then Responder must enclose proof of such SAM registration within its response, which is also a mandatory requirement of this procurement; failure to enclose such proof shall be considered non-compliance with the requirements of this procurement and grounds for the rejection of Responder's response to this procurement (i.e., RFP, RFP, or Proposals statement, as applicable).

44. TRANSACTIONS WITH TERRORIST ORGANIZATIONS PROHIBITED

(Texas Government Code 2252.151; 2252.152) Prohibition on contracts with certain companies per Government Code 2252.151 Definitions:

(1) **"Company"** has the meaning assigned by Section 806.001.

(2) **"Foreign terrorist organization"** means an organization designated as a foreign terrorist organization by the United States secretary of state as authorized by 8 U.S.C. Section 1189.

(3) **"Governmental contract"** means a contract awarded by a governmental entity for general construction, an improvement, a service, or a public works project for a purchase of supplies, materials, or equipment. The term includes a contract to obtain a professional or consulting service subject to Government Code, Chapter 2254.

(4) **"Governmental entity"** has the meaning assigned by Government Code, Section 2252.001.

Pursuant to Chapter 2252, Texas Government Code, Contractor shall certify that, at the time of execution of this Contract, neither the Contractor, nor any wholly owned subsidiary, majority-owned subsidiary, parent company or affiliate of the same (1) engages in business with Iran, Sudan, or any foreign terrorist organization

GENERAL PROVISIONS

REQUEST FOR PROPOSALS MENTAL HEALTH COURT PUBLIC DEFENDER'S OFFICE BUILDOUT GALVESTON COUNTY, TEXAS

as described in Chapters 806 or 807 of the Texas Government Code, or Subchapter F of Chapter 2252 of the Texas Government Code, or (2) is a company listed by the Texas Comptroller of Public Accounts under Sections 806.051, 807.051, or 2252.153 of the Texas Government Code.

45. VERIFICATION NOT TO BOYCOTT ISRAEL

Prohibition on contracts with companies boycotting Israel per Government Code 2271.001 Definitions:

- (1) "**Boycott Israel**" has the meaning assigned by Section 808.001.
- (2) "**Company**" has the meaning assigned by Section 808.001; except that the term does not include a sole proprietorship.
- (2) "**Governmental entity**" has the meaning assigned by Government Code, Section 2251.001.

PROVISION REQUIRED IN CONTRACT. (a) This section applies only to a contract that:

- (1) is between a governmental entity and a company with 10 or more full-time employees; and
- (2) has a value of \$100,000 or more that is to be paid wholly or partly from public funds of the governmental entity.

(b) A governmental entity may not enter into a contract with a company for goods or services unless the contract contains a written verification from the company that it:

- (1) does not boycott Israel; and
- (2) will not boycott Israel during the term of the contract.

As required by GOVERNMENT CODE, CHAPTER 2271, **CONTRACTOR hereby verifies that it does not boycott Israel and will not boycott Israel throughout the term of this Agreement.** For the purposes of this verification, "Boycott Israel" means refusing to deal with, terminating business activities, or otherwise taking any action that is intended to penalize, inflict economic harm on, or limit commercial relations specifically with Israel, or a person or entity doing business in Israel or in an Israeli-controlled territory, but does not include an action made for ordinary business purposes.

46. SOVEREIGN IMMUNITY

The County specifically reserves any claim it may have to sovereign, qualified, or official immunity as a defense to any action arising in conjunction with this contract.

47. CONTROLLING LAW AND VENUE

Responder acknowledges and agrees that the contract is and shall be governed and construed by the laws of the State of Texas and that venue shall lie exclusively in a court of competent jurisdiction in Galveston County, Texas.

48. MERGERS, ACQUISITIONS

The Responder shall be required to notify the County of any potential for merger or acquisition of which there is knowledge at the time that a Statement of Qualification is submitted.

GENERAL PROVISIONS

REQUEST FOR PROPOSALS MENTAL HEALTH COURT PUBLIC DEFENDER'S OFFICE BUILDOUT GALVESTON COUNTY, TEXAS

If subsequent to the award of any contract resulting from this Request for Proposal the Responder shall merge or be acquired by another firm, the following documents must be submitted to the County:

- A. Corporate resolutions prepared by the awarded Responder and the new entity ratifying acceptance of the original contract, terms, conditions and prices;
- B. New entity's Federal Identification Number (FEIN);
- C. New entity's proposed operating plans;
- D. New entity's proof of registration in SAM for contracts involving Federal funds;
- E. New entity's certification regarding debarment;
- F. New entity's certification regarding lobbying; and
- G. W-9 Form for new entity

Moreover, Responder is required to provide the County with notice of any anticipated merger or acquisition as soon as Responder has actual knowledge of the anticipated merger or acquisition. The new Responder's proposed plan of operation must be submitted prior to merger to allow time for submission of such plan to the Commissioners' Court for its approval.

49. DELAYS

The County reserves the right to delay the scheduled commencement date of the contract if it is to the advantage of the County. There shall be no additional costs attributed to these delays should any occur. Responder agrees it will make no claims for damages, for damages for lost revenues, for damages caused by breach of contract with third parties, or any other claim by Responder attributed to these delays, should any occur. In addition, Responder agrees that any contract it enters into with any third party in anticipation of the commencement of the contract will contain a statement that the third party will similarly make no claim for damages based on delay of the scheduled commencement date of the contract.

50. ACCURACY OF DATA

Information and data provided through this Request for Proposal are believed to be reasonably accurate.

51. SUBCONTRACTING/ASSIGNMENT

Responder shall not assign, sell, or otherwise transfer its contract in whole or in part without prior written permission of the County acting by and through its Commissioners' Court. Such consent, if granted, shall not relieve the Responder of any of its responsibilities under this contract.

52. INDEPENDENT CONTRACTOR

Responder expressly acknowledges that it is an independent contractor. Nothing in this agreement is intended nor shall be construed to create an agency relationship, an employer/employee relationship, a joint venture relationship, or any other relationship allowing County to exercise control or direction over the manner or method by which Responder or Responder's subcontractors perform in providing the requirements stated in the Request for Proposal.

GENERAL PROVISIONS

REQUEST FOR PROPOSALS MENTAL HEALTH COURT PUBLIC DEFENDER'S OFFICE BUILDOUT GALVESTON COUNTY, TEXAS

53. MONITORING PERFORMANCE

The County shall have the unfettered right to monitor and audit the Responder's work in every respect. In this regard, the Responder shall provide its full cooperation and ensure the cooperation of its employees, agents, assigns, and subcontractors. Further, the Responder shall make available for inspection and/or copying when requested, original data, records, and accounts relating to the Responder's work and performance under this contract. In the event any such material is not held by the Responder in its original form, a true copy shall be provided.

54. SUBJECT TO APPROPRIATION OF FUNDS

State law prohibits the obligation and expenditure of public funds beyond the fiscal year for which a budget has been approved by the Commissioners' Court. Galveston County anticipates this to be an integral part of future budgets to be approved during the periods of this contract, except for unanticipated needs or events which may prevent such payments against this contract. However, Galveston County cannot guarantee the availability of funds, and enters into this contract only to the extent such funds are made available through appropriation (allocation) by the Commissioners' Court. This contract shall not be construed as creating any debt on behalf of the County of Galveston in violation of TEX. CONST. art. XI, § 7, and it is understood that all obligations of Galveston County are subject to the availability of funds.

55. CONTRACTS SUBJECT TO GRANT FUNDING

Notwithstanding the foregoing, if the contract to be awarded by this procurement is funded with Federal or State grant funds, the Responder acknowledges that the obligations of the County under the contract are contingent upon the continued availability of grant funding to meet the County's obligations. If the grant(s) to the County is reduced, de-obligated, or otherwise discontinued or terminated, Contractor agrees that the County may immediately terminate the contract without penalty or any liability whatsoever on the part of the County, the State, or the Federal awarding agency.

56. PROCUREMENT ETHICS

Galveston County is committed to the highest ethical standards. Therefore, it is a serious breach of the public trust to subvert the public purchasing process by directing purchases to certain favored vendors, or to tamper with the competitive RFP process, whether it's done for kickbacks, friendship or any other reason. Since misuse of the purchasing power of a local government carries criminal penalties, and many such misuses are from a lack of clear guidelines about what constitutes an abuse of office, the Code of Ethics outlined below must be strictly followed.

Galveston County also requires ethical conduct from those who do business with the County.

CODE OF ETHICS – Statement of Purchasing Policy:

Public employment is a public trust. It is the policy of Galveston County to promote and balance the objective of protecting the County's integrity and the objective of facilitating the recruitment and retention of personnel needed by Galveston County. Such policy is implemented by prescribing essential standards of ethical conduct without creating unnecessary obstacles to entering public office.

Public employees must discharge their duties impartially to assure fair competitive access to governmental procurement by responsible contractors. Moreover, they should conduct themselves in such a manner as to foster public confidence in the integrity of the Galveston County procurement organization.

GENERAL PROVISIONS

REQUEST FOR PROPOSALS MENTAL HEALTH COURT PUBLIC DEFENDER'S OFFICE BUILDOUT GALVESTON COUNTY, TEXAS

To achieve the purpose of this Article, it is essential that those doing business with Galveston County also observe the ethical standards prescribed herein.

General Ethical Standards:

It shall be a breach of ethics to attempt to realize personal gain through public employment with Galveston County by any conduct inconsistent with the proper discharge of the employee's duties.

It shall be a breach of ethics to attempt to influence any public employee of Galveston County to breach the standards of ethical conduct set forth in this code.

It shall be a breach of ethics for any employee of Galveston County to participate directly or indirectly in a procurement when the employee knows that:

- The employee or any member of the employee's family, has a financial interest pertaining to the procurement;
- A business or organization in which the employee or any member of the employee's family, has a financial interest pertaining to the procurement; or
- Any other person, business, or organization with which the employee or any member of the employee's family is negotiating or has an arrangement concerning prospective employment is involved in the procurement.

Gratuities:

It shall be a breach of ethics for any person to offer, give, or agree to give any employee or former employee of Galveston County, or for any employee or former employee of Galveston County to solicit, demand, accept or agree to accept from another person, a gratuity or an offer of employment in connection with any decision, approval, disapproval, recommendation, preparation of any part of a program requirement or a purchase request, influencing the content of any specification or procurement standard, rendering of advice, investigation, auditing, or in any other advisory capacity in any proceeding or application, request for ruling, determination, claim or controversy, or other particular matter, pertaining to any program requirement or a contract or subcontract, or to any solicitation or RFP pending before this government.

Kickbacks:

It shall be a breach of ethics for any payment, gratuity or offer of employment to be made by or on behalf of a subcontractor under a contract to the prime contractor or higher tier subcontractor for any contract for Galveston County, or to any person associated therewith, as an inducement for the award of a contract, subcontract or order.

Contract Clause:

The prohibition against gratuities and kickbacks prescribed above shall be conspicuously set forth in every contract and solicitation by Galveston County.

Confidential Information:

GENERAL PROVISIONS

REQUEST FOR PROPOSALS MENTAL HEALTH COURT PUBLIC DEFENDER'S OFFICE BUILDOUT GALVESTON COUNTY, TEXAS

It shall be a breach of ethics for any employee or former employee of Galveston County to knowingly use confidential information for actual or anticipated personal gain, or for the actual or anticipated gain of any other person.

Prohibition against Contingent Fees:

It shall be a breach of ethical standards for a person to be retained, or to retain a person, to solicit or secure a Galveston County contract upon an agreement or understanding for a commission, percentage, brokerage, or contingent fee, except for retention of bona fide employees or bona fide established commercial selling agencies for the purpose of securing business. Failure to aRFPe by this section constitutes a breach of ethical standards.

Representation:

Responder represents and warrants, by signing and submitting its RFP, that it has not retained anyone in violation of this section prohibiting contingent fees.

Contract Clause:

The representation prescribed above shall be conspicuously set forth in every contract and solicitation thereof.

57. NON-COLLUSION AFFIDAVIT

Responder certifies, by signing and submitting a response, that the response is not made in the interest of, or on behalf of, any undisclosed person, partnership, company, association, organization, or corporation; that the response is genuine and not collusive or sham; that the contractor has not directly or indirectly induced or solicited another contractor to put in a false or sham RFP, and has not directly or indirectly colluded, conspired, connived, or agreed with any contractor or anyone else to put in a sham RFP or that anyone shall refrain from responding; that the contractor has not in any manner, directly or indirectly, sought by agreement, communications, or conference with anyone to fix the RFP price of the contractor of any other Responder, or to fix any overhead, profit or cost element of the RFP price, or that of any other contractor, or to secure any advantage against the public body awarding the contract or anyone interested in the proposed contract; that all statements contained in the RFP are true; and further, that the contractor has not, directly or indirectly, submitted his or her RFP price or any breakdown thereof, or the contents thereof, or divulged information or data relative thereto, or paid, and will not pay, any fee to any cooperation, partnership, company association, organization, RFP depository, or to any member or agent thereof to effectuate a collusive or sham RFP.

A blank Non-Collusion Affidavit is included with this RFP packet. Responder must enclose a truthful and fully executed original Non-Collusion Affidavit with the submission of its RFP. This is a mandatory requirement of this Request for Proposal. Failure to include the truthfully and fully executed Non-Collusion Affidavit in the submission of its RFP shall be considered non-compliance with the requirements of this Request for Proposal by the Responder and grounds for the rejection of Responder's submission.

No negotiations, decisions, or actions shall be initiated by any company as a result of any verbal discussion with any County employee prior to the opening of responses to this Request for Proposal.

No officer or employee of the County of Galveston, and no other public or elected official, or employee, who may exercise any function or responsibilities in the review or approval of this undertaking shall have any personal or financial interest, direct or indirect, in any contract or negotiation process thereof. The above compliance request will be part of all County of Galveston contracts for this service.

GENERAL PROVISIONS

REQUEST FOR PROPOSALS MENTAL HEALTH COURT PUBLIC DEFENDER'S OFFICE BUILDOUT GALVESTON COUNTY, TEXAS

58. CERTIFICATION REGARDING LOBBYING – COMPLIANT WITH APPENDIX A TO 24 C.F.R. PART 871

Responder certifies that, to the best of his or her knowledge and belief, that:

- a. No Federal appropriated funds have been paid or will be paid, by or on behalf of the Responder, to any person for influencing or attempting to influence a department or employee of an agency, a member of Congress, or an employee of a member of Congress in connection with the awarding of any Federal contract, the making of any Federal grant, the making of any Federal loan, the entering into of any cooperative agreement, and the extension, continuation, renewal, amendment, or modification of any Federal contract, grant, loan or cooperative agreement.
- b. If any funds other than federal appropriated funds have been paid or will be paid to any person for influencing or attempting to influence a department or employee of any agency, a member of Congress, a department or employee of congress, or an employee of a member of Congress in connection with this federal contract, grant, loan, or cooperative agreement, **the Responder shall complete and submit Standard Form LLL, "Disclosure Form to Report Lobbying", in accordance with its instructions.**
- c. Responder shall require that the language of this certification be included in the award documents for all sub-awards at all tiers (including subcontracts, sub-grants, and contracts under grants, loans, and cooperative agreements) and that all sub-recipients shall certify and disclose accordingly.

This certification is a material representation of fact upon which reliance was placed when this transaction was made or entered into. Submission of the certification is a prerequisite for making or entering into a contract with Responder and is imposed by Section 1352, Title 31, United States Code. Further, any person who fails to file the required certification shall be subject to a civil penalty of not less than \$10,000 and not more than \$100,000 for each such failure.

The truthful and fully completed and executed original of the Certification Regarding Lobbying (included with RFP packet) must be included with the submission of Responder's RFP and is a mandatory requirement of this Request for Proposal. Responder's failure to include the fully completed and executed or original of this Certification shall be considered non-compliant with the requirements of this Request for Proposal and grounds for the rejection of the Responder's RFP.

59. NON-DISCRIMINATION

- a. **Equal Employment Opportunity:** Responder will not discriminate against any employee or applicant for employment because of race, color, religion, national origin, sex, disability, genetic information or veteran status. Responder will take affirmative action to ensure that applicants are employed, and that employees are treated during employment, without regard to their race, color, religion, national origin, sex, disability, genetic information or veteran status. Such action shall include, but not be limited to, the following: employment; upgrading; demotion or transfer; recruitment or recruitment advertising; layoff or termination; rates of pay or other forms of compensation; and selection for training, including apprenticeship. Responder agrees to post in conspicuous places, available to employees and applicants for employment, notices of employment.

Responder will, in all solicitation or advertisements for employees placed by or on behalf of Responder, state that all qualified applicants will receive consideration for employment without regard to race, color, religion, national origin, sex, disability, genetic information, or veteran status.

GENERAL PROVISIONS

REQUEST FOR PROPOSALS MENTAL HEALTH COURT PUBLIC DEFENDER'S OFFICE BUILDOUT GALVESTON COUNTY, TEXAS

Responder will cause the foregoing provisions to be inserted in all subcontracts for any work covered by this Agreement so that such provisions will be binding upon each subcontractor, provided that the foregoing provisions shall not apply to contracts or subcontracts for standard commercial supplies or raw materials.

Responder will include the provisions herein in every subcontract or purchase order unless exempted.

- b. Drug Free Work Place Act: Responder shall comply with all applicable requirements of the Drug-Free Workplace Act of 1988 (Public Law 100-690, Title V, Subtitle D; 41 U.S.C. § 8102, et seq.) and implementing regulations thereunder.
- c. Americans with Disabilities Act: Responder shall comply with all applicable provisions of the Americans with Disabilities Act of 1990 (Public Law 101-136) and implementing regulations thereunder.
- d. OSHA Regulations: Responder agrees to maintain and to display any applicable materials for its employees in accordance with OSHA regulations.
- e. Compliance with Immigration Laws and Use of E-Verify: Responder agrees to comply with all requirements of the U.S. Immigration Reform and Control Act of 1986, as amended, and any implementing regulations thereto. Responder further agrees to utilize the E-Verify system through the Department of Homeland Security on its employees. Responder shall not employ unauthorized aliens and shall not assign services to be performed to any supplier or subcontractor who are unauthorized aliens. If any personnel performing any services hereunder are discovered to be an unauthorized alien, then Responder will immediately remove such personnel from performing services hereunder and shall replace such personnel with personnel who are not unauthorized alien(s).
- f. State and Federal Law Compliance: Responder agrees to comply with all other State and Federal laws and regulations applicable to the provision of services under this contract.
- g. The Contractor shall comply with the Age Discrimination Act of 1975 which provides that no person in the United States shall on the basis of age be excluded from participation in, be denied the benefits of, or be subjected to discrimination under any program or activity receiving federal financial assistance.

60. RECORD RETENTION AND RIGHT TO AUDIT

Responder shall keep and maintain all records associated with this contract for a minimum of five (5) years from the close of the contract or as required by Federal or State law or regulation, whichever period is longer. If awarded this contract, Responder shall allow the County reasonable access to the records in Responder's possession, custody, or control that the County deems necessary to assist it in auditing the services, costs, and payments provided hereunder. If this contract involves the use of Federal or State funds, then Responder shall also allow reasonable access to representatives of the Office of Inspector General, the General Accounting Office, the State Auditor's Office, and the other Federal and/or State agencies overseeing the funds that such entities deem necessary to facilitate review by such agencies and Responder shall maintain fiscal records and supporting documentation for all expenditures in a manner that conforms with OMB Circular A-87 (relocated to 2 C.F.R. Part 225) and this contract.

61. TITLE VI ASSURANCES / TxDOT

The County is subject to Title VI of the Civil Rights Act of 1964 and the Federal and State laws and regulations of the United States Department of Transportation and Texas Department of Transportation (TxDOT). Pursuant

GENERAL PROVISIONS

REQUEST FOR PROPOSALS MENTAL HEALTH COURT PUBLIC DEFENDER'S OFFICE BUILDOUT GALVESTON COUNTY, TEXAS

to these requirements, the County must have its contractors provide required assurances on compliance with non-discrimination by itself and its subcontractors. The Title VI Assurances within this Subsection are not exhaustive – whenever any Federal, State, or Local requirement requires additional clauses, this list shall not be construed as limiting. Contractor agrees as follows:

- (1) **Compliance with Regulations:** The Contractor shall comply with the Regulations relative to nondiscrimination in Federally assisted programs of the Department of Transportation (hereinafter, DOT) Title 49, Code of Federal Regulations, Part 21, as they may be amended from time to time (hereinafter referred to as the Regulations), which are incorporated herein by reference and made a part of this contract.
- (2) **Non-discrimination:** The Contractor, with regard to the work performed by it during the contract, shall not discriminate on the basis of race, color, national origin, religion, sex, age, disability or Veteran status in the selection and retention of subcontractors, including procurements of materials and leases of equipment. The Contractor shall not participate either directly or indirectly in the discrimination prohibited by Section 21.5 of the Regulations, including employment practices when the contract covers a program set forth in Appendix B of the Regulations.
- (3) **Solicitations for Subcontractors, Including Procurement of Materials and Equipment:** In all solicitations either by competitive solicitation or negotiation made by the Contractor for work to be performed under a subcontract, including procurement of materials or leases of equipment, each potential subcontractor or supplier shall be notified by the Contractor of the Contractor's obligations under this contract and the Regulations relative to nondiscrimination on the grounds of race, color, national origin, religion, sex, age, disability or Veteran status.
- (4) **Information and Reports:** The Contractor shall provide all information and reports required by the Regulations or directives issued pursuant thereto, and shall permit access to its books, records, accounts, other sources of information and its facilities as may be determined by the Galveston County or the Texas Department of Transportation to be pertinent to ascertain compliance with such Regulations, orders and instructions. Where any information required of the Contractor is in the exclusive possession of another who fails or refuses to furnish this information the Contractor shall so certify to Galveston County or the Texas Department of Transportation as appropriate and shall set forth what efforts it has made to obtain the information.
- (5) **Sanctions for Non-compliance:** In the event of the Contractor's noncompliance with the nondiscrimination provisions of this contract, Galveston County shall impose such contract sanctions as it or the Texas Department of Transportation may determine to be appropriate, including, but not limited to:
 - (a) withholding of payments to the Contractor under the contract until the Contractor complies, and/or;
 - (b) cancellation, termination, or suspension of the contract, in whole or in part.
- (6) **Incorporation of Provisions.** The Contractor shall include the provisions of paragraphs (1) through (6) in every subcontract, including procurement of materials and leases of equipment, unless exempt by the Regulations, or directives issued pursuant thereto. The Contractor shall take such action with respect to any subcontract or procurement as Galveston County or the Texas Department of Transportation may direct as a means of enforcing such provisions including sanctions for non-compliance: Provided, however, that, in the event Contractor becomes involved in, or is threatened with, litigation with a subcontractor or supplier as a result of such direction, the Contractor may request Galveston County to

GENERAL PROVISIONS

REQUEST FOR PROPOSALS MENTAL HEALTH COURT PUBLIC DEFENDER'S OFFICE BUILDOUT GALVESTON COUNTY, TEXAS

enter into such litigation to protect the interests of Galveston County, and, in addition, the Contractor may request the United States to enter into such litigation to protect the interests of the United States.

62. ASSURANCES FOR CONSTRUCTION PROGRAMS - TEXAS GENERAL LAND OFFICE (GLO)

The County is subject to Federal and State laws and regulations of the United States and The Texas General Land Office (GLO). Pursuant to these requirements, the County must have its contractors provide required assurances on compliance with non-discrimination by itself and its subcontractors. These Assurances within this Subsection are not exhaustive – whenever any Federal, State, or Local requirement requires additional clauses, this list shall not be construed as limiting. Contractor agrees as follows:

- (1) Will comply with the Intergovernmental Personnel Act of 1970 (42 U.S.C. §§4728-4763) relating to prescribed standards for merit systems for programs funded under one of the 19 statutes or regulations specified in Appendix A of OPM's Standards for a Merit System of Personnel Administration (5 C.F.R. 900, Subpart F).
- (2) Will comply with the Lead-Based Paint Poisoning Prevention Act (42 U.S.C. §§4801 et seq.) which prohibits the use of lead-based paint in construction or rehabilitation of residence structures.
- (3) Will comply with all Federal statutes relating to non-discrimination. These include but are not limited to: (a) Title VI of the Civil Rights Act of 1964 (P.L. 88-352) which prohibits discrimination on the basis of race, color or national origin; (b) Title IX of the Education Amendments of 1972, as amended (20 U.S.C. §§1681-1683, and 1685-1686), which prohibits discrimination on the basis of sex; (c) Section 504 of the Rehabilitation Act of 1973, as amended (29 U.S.C. §794), which prohibits discrimination on the basis of handicaps; (d) the Age Discrimination Act of 1975, as amended (42 U.S.C. §§6101-6107), which prohibits discrimination on the basis of age; (e) the Drug Abuse Office and Treatment Act of 1972 (P.L. 92-255), as amended, relating to nondiscrimination on the basis of drug abuse; (f) the Comprehensive Alcohol Abuse and Alcoholism Prevention, Treatment and Rehabilitation Act of 1970 (P.L. 91-616), as amended, relating to nondiscrimination on the basis of alcohol abuse or alcoholism; (g) §§523 and 527 of the Public Health Service Act of 1912 (42 U.S.C. §§290 dd-3 and 290 ee-3), as amended, relating to confidentiality of alcohol and drug abuse patient records; (h) Title VIII of the Civil Rights Act of 1968 (42 U.S.C. §§3601 et seq.), as amended, relating to nondiscrimination in the sale, rental or financing of housing; (i) any other non-discrimination provisions in the specific statute(s) under which application for Federal assistance is being made; and (j) the requirements of any other nondiscrimination statute(s) which may apply to the application.
- (4) Will comply with the Intergovernmental Personnel Act of 1970 (42 U.S.C. §§4728-4763) relating to prescribed standards for merit systems for programs funded under one of the 19 statutes or regulations specified in Appendix A of OPM's Standards for a Merit System of Personnel Administration (5 C.F.R. 900, Subpart F).
- (5) Will comply with the Lead-Based Paint Poisoning Prevention Act (42 U.S.C. §§4801 et seq.) which prohibits the use of lead-based paint in construction or rehabilitation of residence structures.
- (6) Will comply with all Federal statutes relating to non-discrimination. These include but are not limited to: (a) Title VI of the Civil Rights Act of 1964 (P.L. 88-352) which prohibits discrimination

GENERAL PROVISIONS

REQUEST FOR PROPOSALS MENTAL HEALTH COURT PUBLIC DEFENDER'S OFFICE BUILDOUT GALVESTON COUNTY, TEXAS

- on the basis of race, color or national origin; (b) Title IX of the Education Amendments of 1972, as amended (20 U.S.C. §§1681-1683, and 1685-1686), which prohibits discrimination on the basis of sex; (c) Section 504 of the Rehabilitation Act of 1973, as amended (29 U.S.C. §794), which prohibits discrimination on the basis of handicaps; (d) the Age Discrimination Act of 1975, as amended (42 U.S.C. §§6101-6107), which prohibits discrimination on the basis of age; (e) the Drug Abuse Office and Treatment Act of 1972 (P.L. 92-255), as amended, relating to nondiscrimination on the basis of drug abuse; (f) the Comprehensive Alcohol Abuse and Alcoholism Prevention, Treatment and Rehabilitation Act of 1970 (P.L. 91-616), as amended, relating to nondiscrimination on the basis of alcohol abuse or alcoholism; (g) §§523 and 527 of the Public Health Service Act of 1912 (42 U.S.C. §§290 dd-3 and 290 ee-3), as amended, relating to confidentiality of alcohol and drug abuse patient records; (h) Title VIII of the Civil Rights Act of 1968 (42 U.S.C. §§3601 et seq.), as amended, relating to nondiscrimination in the sale, rental or financing of housing; (i) any other non-discrimination provisions in the specific statute(s) under which application for Federal assistance is being made; and (j) the requirements of any other nondiscrimination statute(s) which may apply to the application.
- (7) Will comply, or has already complied, with the requirements of Titles II and III of the Uniform Relocation Assistance and Real Property Acquisition Policies Act of 1970 (P.L. 91-646) which provide for fair and equitable treatment of persons displaced or whose property is acquired as a result of Federal and federally assisted programs. These requirements apply to all interests in real property acquired for project purposes regardless of Federal participation in purchases.
- (8) Will comply with the provisions of the Hatch Act (5 U.S.C. §§1501-1508 and 7324-7328) which limit the political activities of employees whose principal employment activities are funded in whole or in part with Federal funds.
- (9) Will comply, as applicable, with the provisions of the Davis- Bacon Act (40 U.S.C. §§276a to 276a-7), the Copeland Act (40 U.S.C. §276c and 18 U.S.C. §874), and the Contract Work Hours and Safety Standards Act (40 U.S.C. §§327-333) regarding labor standards for federally assisted construction sub agreements.
- (10) Will comply with flood insurance purchase requirements of Section 102(a) of the Flood Disaster Protection Act of 1973 (P.L. 93-234) which requires recipients in a special flood hazard area to participate in the program and to purchase flood insurance if the total cost of insurable construction and acquisition is \$10,000 or more.
- (11) Will comply with environmental standards which may be prescribed pursuant to the following: (a) institution of environmental quality control measures under the National Environmental Policy Act of 1969 (P.L. 91-190) and Executive Order (EO) 11514; (b) notification of violating facilities pursuant to EO 11738; (c) protection of wetlands pursuant to EO 11990; (d) evaluation of flood hazards in floodplains in accordance with EO 11988; (e) assurance of project consistency with the approved State management program developed under the Coastal Zone Management Act of 1972 (16 U.S.C. §§1451 et seq.); (f) conformity of Federal actions to State (Clean Air) Implementation Plans under Section 176(c) of the Clean Air Act of 1955, as amended (42 U.S.C. §§7401 et seq.); (g) protection of underground sources of drinking water under the Safe Drinking Water Act of

GENERAL PROVISIONS

REQUEST FOR PROPOSALS MENTAL HEALTH COURT PUBLIC DEFENDER'S OFFICE BUILDOUT GALVESTON COUNTY, TEXAS

1974, as amended (P.L. 93-523); and, (h) protection of endangered species under the Endangered Species Act of 1973, as amended (P.L. 93205).

- (12) Will comply with the Wild and Scenic Rivers Act of 1968 (16 U.S.C. §§1271 et seq.) related to protecting components or potential components of the national wild and scenic rivers system.
- (13) Will assist the awarding agency in assuring compliance with Section 106 of the National Historic Preservation Act of 1966, as amended (16 U.S.C. §470), EO 11593 (identification and protection of historic properties), and the Archaeological and Historic Preservation Act of 1974 (16 U.S.C. §§469a-1 et seq.).
- (14) Will cause to be performed the required financial and compliance audits in accordance with the Single Audit Act Amendments of 1996 and OMB Circular No. A-133, "Audits of States, Local Governments, and Non-Profit Organizations."
- (15) Will comply with all applicable requirements of all other Federal laws, executive orders, regulations, and policies governing this program.
- (16) Will comply with the requirements of Section 106(g) of the Trafficking Victims Protection Act (TVPA) of 2000, as amended (22 U.S.C. 7104) which prohibits grant award recipients or a sub-recipient from (1) Engaging in severe forms of trafficking in persons during the period of time that the award is in effect (2) Procuring a commercial sex act during the period of time that the award is in effect or (3) Using forced labor in the performance of the award or subawards under the award.

63. GENERAL AFFIRMATIONS – TEXAS GENERAL LAND OFFICE (GLO)

To the extent they apply, affirms, and agrees to the following, without exception:

1. represents and warrants that, in accordance with Section 2155.005 of the Texas Government Code, neither nor the firm, corporation, partnership, or institution represented by , or anyone acting for such a firm, corporation, partnership, or institution has (1) violated any provision of the Texas Free Enterprise and Antitrust Act of 1983, Chapter 15 of the Texas Business and Commerce Code, or the federal antitrust laws, or (2) communicated directly or indirectly the contents of this Contract or any solicitation response upon which this Contract is based to any competitor or any other person engaged in the same line of business as .
2. If the Contract is for services, shall comply with Section 2155.4441 of the Texas Government Code, requiring the purchase of products and materials produced in the State of Texas in performing service contracts.
3. Under Section 231.006 of the Family Code, the vendor or applicant certifies that the individual or business entity named in this Contract, RFP or application is not ineligible to receive the specified grant, loan, or payment and acknowledges that this Contract may be terminated and payment may be withheld if this certification is inaccurate.
4. A RFP or an application for a contract, grant, or loan paid from state funds must include the name and social security number of the individual or sole proprietor and each partner, shareholder, or owner with

GENERAL PROVISIONS

REQUEST FOR PROPOSALS MENTAL HEALTH COURT PUBLIC DEFENDER'S OFFICE BUILDOUT GALVESTON COUNTY, TEXAS

an ownership interest of at least 25 percent of the business entity submitting the RFP or application certifies it has submitted this information to the GLO.

5. If the Contract is for the purchase or lease of computer equipment, as defined by Texas Health and Safety Code Section 361.952(2), certifies that it is in compliance with Subchapter Y, Chapter 361 of the Texas Health and Safety Code, related to the Computer Equipment Recycling Program and the Texas Commission on Environmental Quality rules in Title 30 Texas Administrative Code Chapter 328.
6. Pursuant to Section 2155.003 of the Texas Government Code, represents and warrants that it has not given, offered to give, nor intends to give at any time hereafter any economic opportunity, future employment, gift, loan, gratuity, special discount, trip, favor, or service to a public servant in connection with the Contract.
7. Payments due under the Contract shall be directly applied towards eliminating any debt or delinquency owes to the State of Texas including, but not limited to, delinquent taxes, delinquent student loan payments, and delinquent child support.
8. Upon request of the GLO, shall provide copies of its most recent business continuity and disaster recovery plans.
9. If the Contract is for consulting services governed by Texas Government Code Chapter 2254, Subchapter B, in accordance with Section 2254.033 of the Texas Government Code, relating to consulting services, certifies that it does not employ an individual who has been employed by The GLO or another agency at any time during the two years preceding the 's submission of its offer to provide consulting services to the GLO or, in the alternative, , in its offer to provide consulting services to the GLO, disclosed the following: (i) the nature of the previous employment with the GLO or other state agency; (ii) the date the employment was terminated; and (iii) the annual rate of compensation for the employment at the time of its termination.
10. If the Contract is not for architecture, engineering, or construction services, except as otherwise provided by statute, rule, or regulation, must use the dispute resolution process provided for in Chapter 2260 of the Texas Government Code to attempt to resolve any dispute arising under the Contract. **NOTHING IN THIS SECTION SHALL BE CONSTRUED AS A WAIVER OF SOVEREIGN IMMUNITY BY THE GLO.**
11. If the Contract is for architecture, engineering, or construction services, subject to Texas Government Code, Section 2260.002 and Texas Civil Practice and Remedies Code Chapter 114, and except as otherwise provided by statute, rule, or regulation, shall use the dispute resolution process provided for in Chapter 2260 of the Texas Government Code to attempt to resolve all disputes arising under this Contract. Except as otherwise provided by statute, rule, or regulation, in accordance with the Texas Civil Practice and Remedies Code, Section 114.005, claims encompassed by Texas Government Code, Section 2260.002(3) and Texas Civil Practice and Remedies Code Section 114.002 shall be governed by the dispute resolution process set forth below in subsections (a)-(d). **NOTHING IN THIS SECTION SHALL BE CONSTRUED AS A WAIVER OF SOVEREIGN IMMUNITY BY THE GLO.**
 - a. Notwithstanding Texas Government Code, Chapter 2260.002(3) and Chapter 114.012 and any other statute or applicable law, if the claim for breach of contract cannot be resolved by the parties in the ordinary course of business, may make a claim against the GLO for breach of contract and the GLO

GENERAL PROVISIONS

REQUEST FOR PROPOSALS MENTAL HEALTH COURT PUBLIC DEFENDER'S OFFICE BUILDOUT GALVESTON COUNTY, TEXAS

- may assert a counterclaim against the as is contemplated by Texas Government Code, Chapter 2260, Subchapter B. In such event, must provide written notice to the GLO of a claim for breach of the Contract not later than the 180th day after the date of the event giving rise to the claim. The notice must state with particularity: (1) the nature of the alleged breach; (2) the amount the seeks as damages; and (3) the legal theory of recovery.
- b. The chief administrative officer, or if designated in the Contract, another officer of the GLO, shall examine the claim and any counterclaim and negotiate with the in an effort to resolve them. The negotiation must begin no later than the 120th day after the date the claim is received, as is contemplated by Texas Government Code, Chapter 2260, Section 2260.052.
 - c. If the negotiation under paragraph (b) above results in the resolution of some disputed issues by agreement or in a settlement, the parties shall reduce the agreement or settlement to writing and each party shall sign the agreement or settlement. A partial settlement or resolution of a claim does not waive a party's rights under this Contract as to the parts of the claim that are not resolved.
 - d. If a claim is not entirely resolved under paragraph (b) above, on or before the 270th day after the date the claim is filed with the GLO, unless the parties agree in writing to an extension of time, the parties may agree to mediate a claim made under this dispute resolution procedure. This dispute resolution procedure is the 's sole and exclusive process for seeking a remedy for an alleged breach of contract by the GLO if the parties are unable to resolve their disputes as described in this section.
 - e. Nothing in the Contract shall be construed as a waiver of the state's or the GLO's sovereign immunity. This Contract shall not constitute or be construed as a waiver of any of the privileges, rights, defenses, remedies, or immunities available to the State of Texas. The failure to enforce, or any delay in the enforcement, of any privileges, rights, defenses, remedies, or immunities available to the State of Texas under this Contract or under applicable law shall not constitute a waiver of such privileges, rights, defenses, remedies or immunities or be considered as a basis for estoppel. The GLO does not waive any privileges, rights, defenses, or immunities available to it by entering into this Contract or by its conduct, or by the conduct of any representative of the GLO, prior to or subsequent to entering into this Contract.
 - f. Except as otherwise provided by statute, rule, or regulation, compliance with the dispute resolution process provided for in Texas Government Code, Chapter 2260, subchapter B and incorporated by reference in subsection (a)-(d) above is a condition precedent to the: (1) filing suit pursuant to Chapter 114 of the Civil Practices and Remedies Code; or (2) initiating a contested case hearing pursuant to Subchapter C of Chapter 2260 of the Texas Government Code.
12. If Texas Government Code Chapter 2270 prohibiting state contracts with companies boycotting Israel applies to and this Contract, then verifies it does not boycott Israel and will not boycott Israel during the term of this Contract.
 13. This Contract is contingent upon the continued availability of lawful appropriations by the Texas Legislature. understands that all obligations of the GLO under this Contract are subject to the availability of state funds. If such funds are not appropriated or become unavailable, the GLO may terminate the Contract. The Contract shall not be construed as creating a debt on behalf of the GLO in violation of Article III, Section 49a of the Texas Constitution.

GENERAL PROVISIONS

REQUEST FOR PROPOSALS MENTAL HEALTH COURT PUBLIC DEFENDER'S OFFICE BUILDOUT GALVESTON COUNTY, TEXAS

14. certifies that it is not listed on the federal government's terrorism watch list as described in Executive Order 13224.
15. In accordance with Section 669.003 of the Texas Government Code, relating to contracting with the executive head of a state agency, certifies that it is not (1) the executive head of the GLO, (2) a person who at any time during the four years before the effective date of the Contract was the executive head of the GLO, or (3) a person who employs a current or former executive head of the GLO.
16. represents and warrants that all statements and information prepared and submitted in connection with this Contract are current, complete, true, and accurate. Submitting a false statement or making a material misrepresentation during the performance of this Contract is a material breach of contract and may void the Contract or be grounds for its termination.
17. Pursuant to Section 2155.004(a) of the Texas Government Code, certifies that neither nor any person or entity represented by has received compensation from the GLO to participate in the preparation of the specifications or solicitation on which this Contract is based. Under Section 2155.004(b) of the Texas Government Code, certifies that the individual or business entity named in this Contract is not ineligible to receive the specified contract and acknowledges that the Contract may be terminated and payment withheld if this certification is inaccurate. This Section does not prohibit from providing free technical assistance.
18. represents and warrants that it is not engaged in business with Iran, Sudan, or a foreign terrorist organization, as prohibited by Section 2252.152 of the Texas Government Code.
19. If the Contract is for professional or consulting services governed by Texas Government Code Chapter 2254, represents and warrants that none of its employees including, but not limited to, those authorized to provide services under the Contract, were former employees of the GLO during the twelve (12) month period immediately prior to the date of execution of the Contract.
20. The Contract shall be governed by and construed in accordance with the laws of the State of Texas, without regard to the conflicts of law provisions. The venue of any suit arising under the Contract is fixed in any court of competent jurisdiction of Travis County, Texas, unless the specific venue is otherwise identified in a statute which directly names or otherwise identifies its applicability to the GLO.
21. IF THE CONTRACT IS NOT FOR ARCHITECTURE OR ENGINEERING SERVICES GOVERNED BY TEXAS GOVERNMENT CODE CHAPTER 2254, , TO THE EXTENT ALLOWED BY LAW, SHALL DEFEND, INDEMNIFY AND HOLD HARMLESS THE STATE OF TEXAS AND THE GLO, AND/OR THEIR OFFICERS, AGENTS, EMPLOYEES, REPRESENTATIVES, CONTRACTORS, ASSIGNEES, AND/OR DESIGNEES FROM ANY AND ALL LIABILITY, ACTIONS, CLAIMS, DEMANDS, OR SUITS, AND ALL RELATED COSTS, ATTORNEY FEES, AND EXPENSES ARISING OUT OF, OR RESULTING FROM ANY ACTS OR OMISSIONS OF OR ITS AGENTS, EMPLOYEES, SUBCONTRACTORS, ORDER FULFILLERS, OR SUPPLIERS OF SUBCONTRACTORS IN THE EXECUTION OR PERFORMANCE OF THE CONTRACT AND ANY PURCHASE ORDERS ISSUED UNDER THE CONTRACT. THE DEFENSE SHALL BE COORDINATED BY WITH THE OFFICE OF THE TEXAS ATTORNEY GENERAL WHEN TEXAS STATE AGENCIES ARE NAMED DEFENDANTS IN ANY LAWSUIT AND MAY NOT AGREE TO ANY SETTLEMENT WITHOUT FIRST OBTAINING THE CONCURRENCE FROM THE

GENERAL PROVISIONS

REQUEST FOR PROPOSALS MENTAL HEALTH COURT PUBLIC DEFENDER'S OFFICE BUILDOUT GALVESTON COUNTY, TEXAS

OFFICE OF THE TEXAS ATTORNEY GENERAL. AND THE GLO SHALL FURNISH TIMELY WRITTEN NOTICE TO EACH OTHER OF ANY SUCH CLAIM.

22. IF THE CONTRACT IS FOR ARCHITECTURE OR ENGINEERING SERVICES GOVERNED BY TEXAS GOVERNMENT CODE CHAPTER 2254, , TO THE EXTENT ALLOWED BY LAW, SHALL INDEMNIFY AND HOLD HARMLESS THE STATE OF TEXAS AND THE GLO, AND/OR THEIR OFFICERS, AGENTS, EMPLOYEES, REPRESENTATIVES, CONTRACTORS, ASSIGNEES, AND/OR DESIGNEES FROM ANY AND ALL LIABILITY, ACTIONS, CLAIMS, DEMANDS, OR SUITS, AND ALL RELATED DAMAGES, COSTS, ATTORNEY FEES, AND EXPENSES TO THE EXTENT CAUSED BY, ARISING OUT OF, OR RESULTING FROM ANY ACTS OF NEGLIGENCE, INTENTIONAL TORTS, WILLFUL MISCONDUCT, PERSONAL INJURY OR DAMAGE TO PROPERTY, AND/OR OTHERWISE RELATED TO 'S PERFORMANCE, AND/OR FAILURES TO PAY A SUBCONTRACTOR OR SUPPLIER BY THE OR ITS AGENTS, EMPLOYEES, SUBCONTRACTORS, ORDER FULFILLERS, CONSULTANTS UNDER CONTRACT TO , OR ANY OTHER ENTITY OVER WHICH THE CONTRACTOR EXERCISES CONTROL, OR SUPPLIERS OF SUBCONTRACTORS IN THE EXECUTION OR PERFORMANCE OF THE CONTRACT. THE DEFENSE SHALL BE COORDINATED BY WITH THE OFFICE OF THE TEXAS ATTORNEY GENERAL WHEN TEXAS STATE AGENCIES ARE NAMED DEFENDANTS IN ANY LAWSUIT AND MAY NOT AGREE TO ANY SETTLEMENT WITHOUT FIRST OBTAINING THE CONCURRENCE FROM THE OFFICE OF THE TEXAS ATTORNEY GENERAL. AND THE GLO SHALL FURNISH TIMELY WRITTEN NOTICE TO EACH OTHER OF ANY SUCH CLAIM.
23. TO THE EXTENT ALLOWED BY LAW, SHALL DEFEND, INDEMNIFY, AND HOLD HARMLESS THE GLO AND THE STATE OF TEXAS FROM AND AGAINST ANY AND ALL CLAIMS, VIOLATIONS, MISAPPROPRIATIONS OR INFRINGEMENT OF ANY PATENT, TRADEMARK, COPYRIGHT, TRADE SECRET OR OTHER INTELLECTUAL PROPERTY RIGHTS AND/OR OTHER INTANGIBLE PROPERTY, PUBLICITY OR PRIVACY RIGHTS, AND/OR IN CONNECTION WITH OR ARISING FROM: (1) THE PERFORMANCE OR ACTIONS OF PURSUANT TO THIS CONTRACT; (2) ANY DELIVERABLE, WORK PRODUCT, CONFIGURED SERVICE OR OTHER SERVICE PROVIDED HEREUNDER; AND/OR (3) THE GLO'S AND/OR 'S USE OF OR ACQUISITION OF ANY REQUESTED SERVICES OR OTHER ITEMS PROVIDED TO THE GLO BY OR OTHERWISE TO WHICH THE GLO HAS ACCESS AS A RESULT OF 'S PERFORMANCE UNDER THE CONTRACT. AND THE GLO SHALL FURNISH TIMELY WRITTEN NOTICE TO EACH OTHER OF ANY SUCH CLAIM. SHALL BE LIABLE TO PAY ALL COSTS OF DEFENSE, INCLUDING ATTORNEYS' FEES. THE DEFENSE SHALL BE COORDINATED BY WITH THE OFFICE OF THE TEXAS ATTORNEY GENERAL (OAG) WHEN TEXAS STATE AGENCIES ARE NAMED DEFENDANTS IN ANY LAWSUIT AND MAY NOT AGREE TO ANY SETTLEMENT WITHOUT FIRST OBTAINING THE CONCURRENCE FROM OAG. IN ADDITION, WILL REIMBURSE THE GLO AND THE STATE OF TEXAS FOR ANY CLAIMS, DAMAGES, COSTS, EXPENSES OR OTHER AMOUNTS, INCLUDING, BUT NOT LIMITED TO, ATTORNEYS' FEES AND COURT COSTS, ARISING FROM ANY SUCH CLAIM. IF THE GLO DETERMINES THAT A CONFLICT EXISTS BETWEEN ITS INTERESTS AND THOSE OF OR IF THE GLO IS REQUIRED BY APPLICABLE LAW TO SELECT SEPARATE COUNSEL, THE GLO WILL BE PERMITTED TO SELECT SEPARATE COUNSEL AND WILL PAY ALL REASONABLE COSTS OF THE GLO'S COUNSEL.

GENERAL PROVISIONS

REQUEST FOR PROPOSALS MENTAL HEALTH COURT PUBLIC DEFENDER'S OFFICE BUILDOUT GALVESTON COUNTY, TEXAS

24. has disclosed in writing to the GLO all existing or potential conflicts of interest relative to the performance of the Contract.
25. Sections 2155.006 and 2261.053 of the Texas Government Code prohibit state agencies from accepting a solicitation response or awarding a contract that includes proposed financial participation by a person who, in the past five years, has been convicted of violating a federal law or assessed a penalty in connection with a contract involving relief for Hurricane Rita, Hurricane Katrina, or any other disaster, as defined by Section 418.004 of the Texas Government Code, occurring after September 24, 2005. Under Sections 2155.006 and 2261.053 of the Texas Government Code, certifies that the individual or business entity named in this Contract is not ineligible to receive the specified contract and acknowledges that this Contract may be terminated and payment withheld if this certification is inaccurate.
26. understands that the GLO will comply with the Texas Public Information Act (Chapter 552 of the Texas Government Code) as interpreted by judicial rulings and opinions of the Attorney General of the State of Texas. Information, documentation, and other material related to this Contract may be subject to public disclosure pursuant to the Texas Public Information Act. In accordance with Section 2252.907 of the Texas Government Code, shall make any information created or exchanged with the State/GLO pursuant to the Contract, and not otherwise excepted from disclosure under the Texas Public Information Act, available in a format that is accessible by the public at no additional charge to the State or the GLO.
27. The person executing this Contract certifies that he/she is duly authorized to execute this Contract on his/her own behalf or on behalf of and legally empowered to contractually bind to the terms and conditions of the Contract and related documents.
28. If the Contract is for architectural or engineering services, pursuant to Section 2254.0031 of the Texas Government Code, which incorporates by reference Section 271.904(d) of the Texas Local Government Code, shall perform services (1) with professional skill and care ordinarily provided by competent engineers or architects practicing under the same or similar circumstances and professional license, and (2) as expeditiously as is prudent considering the ordinary professional skill and care of a competent engineer or architect.
29. The state auditor may conduct an audit or investigation of any entity receiving funds from the state directly under the Contract or indirectly through a subcontract under the Contract. The acceptance of funds directly under the Contract or indirectly through a subcontract under the Contract acts as acceptance of the authority of the state auditor, under the direction of the legislative audit committee, to conduct an audit or investigation in connection with those funds. Under the direction of the legislative audit committee, an entity that is the subject of an audit or investigation by the state auditor must provide the state auditor with access to any information the state auditor considers relevant to the investigation or audit. shall ensure that this paragraph concerning the authority to audit funds received indirectly by subcontractors through the Contract and the requirement to cooperate is included in any subcontract it awards. The GLO may unilaterally amend the Contract to comply with any rules and procedures of the state auditor in the implementation and enforcement of Section 2262.154 of the Texas Government Code.
30. certifies that neither it nor its principals are debarred, suspended, proposed for debarment, declared ineligible, or otherwise excluded from participation in the Contract by any state or federal agency.
31. expressly acknowledges that state funds may not be expended in connection with the purchase of an automated information system unless that system meets certain statutory requirements relating to

GENERAL PROVISIONS

REQUEST FOR PROPOSALS MENTAL HEALTH COURT PUBLIC DEFENDER'S OFFICE BUILDOUT GALVESTON COUNTY, TEXAS

accessibility by persons with visual impairments. Accordingly, represents and warrants to the GLO that any technology provided to the GLO for purchase pursuant to this Contract is capable, either by virtue of features included within the technology or because it is readily adaptable by use with other technology, of: providing equivalent access for effective use by both visual and non-visual means; presenting information, including prompts used for interactive communications, in formats intended for non-visual use; and being integrated into networks for obtaining, retrieving, and disseminating information used by individuals who are not blind or visually impaired. For purposes of this Section, the phrase "equivalent access" means a substantially similar ability to communicate with or make use of the technology, either directly by features incorporated within the technology or by other reasonable means such as assistive devices or services which would constitute reasonable accommodations under the Americans With Disabilities Act or similar state or federal laws. Examples of methods by which equivalent access may be provided include, but are not limited to, keyboard alternatives to mouse commands and other means of navigating graphical displays, and customizable display appearance.

32. If the Contract is for the purchase or lease of covered television equipment, as defined by Section 361.971(3) of the Texas Health and Safety Code, certifies its compliance with Subchapter Z, Chapter 361 of the Texas Health and Safety Code, related to the Television Equipment Recycling Program.

33. Pursuant to Section 572.069 of the Texas Government Code, certifies it has not employed and will not employ a former state officer or employee who participated in a procurement or contract negotiations for the GLO involving within two (2) years after the date that the contract is signed or the procurement is terminated or withdrawn. This certification only applies to former state officers or employees whose state service or employment ceased on or after September 1, 2015.

34. The GLO does not tolerate any type of fraud. GLO policy promotes consistent, legal, and ethical organizational behavior by assigning responsibilities and providing guidelines to enforce controls. Any violations of law, agency policies, or standards of ethical conduct will be investigated, and appropriate actions will be taken. shall report any possible fraud, waste, or abuse that occurs in connection with the Contract to the GLO's Fraud Reporting hotline at (877) 888-0002.

35. The requirements of Subchapter J, Chapter 552, Government Code, may apply to this contract and agrees that the Contract can be terminated if knowingly or intentionally fails to comply with a requirement of that subchapter.

36. If, in its performance of the Contract, has access to a state computer system or database, must complete a cybersecurity training program certified under Texas Government Code Section 2054.519, as selected by the GLO. must complete the cybersecurity training program during the initial term of the Contract and during any renewal period. must verify in writing to the GLO its completion of the cybersecurity training program.

37. Under Section 2155.0061, Texas Government Code, certifies that the entity named in this contract is not ineligible to receive the specified contract and acknowledges that this contract may be terminated and payment withheld if this certification is inaccurate.

64. SECTION 231.006, FAMILY CODE/DELINQUENT CHILD SUPPORT

Pursuant to Title 5, Section 231.006 of the Texas Family Code, as applicable, Responder certifies that it, including all its principals, is/are current in child support payments and that it is eligible to receive payments

GENERAL PROVISIONS

REQUEST FOR PROPOSALS MENTAL HEALTH COURT PUBLIC DEFENDER'S OFFICE BUILDOUT GALVESTON COUNTY, TEXAS

from State funds under a contract for property, materials, or services. Responder acknowledges and agrees that if it is awarded this contract, then the ensuing agreement may be terminated, and payment withheld if this certification is inaccurate. Finally, by the submission of its RFP, the Responder certifies that it has included the names and social security numbers of each person with at least 25% ownership interest in Responder within its response to the Request for Proposal and that all such persons are current in child support payments.

65. ANTITRUST

Pursuant to 15 U.S.C. § 1, et seq., and Texas Business and Commerce Code, Chapter 15, Contractor, by the submission of its RFP, certifies that neither Contractor nor any natural person, proprietorship, firm, corporation, partnership, association, or institution represented by Contractor or anyone acting for such natural person, proprietorship, firm, corporation, partnership, association, or institution has violated any Federal or State antitrust laws or communicated the nature of the offer, directly or indirectly, to any competitor or other person engaged in a similar line of business.

66. LABOR STANDARDS

On contracts funded under a federal grant: Responder acknowledges that the contract to be awarded pursuant to this solicitation is on a grant program funded with Federal funds. Responder shall comply with the requirements of 29 CFR Part 5 and Part 30 and shall be in conformity with Executive Order 11246, entitled "Equal Employment Opportunity", Copeland, "Anti-Kickback" Act (40 U.S.C. 3145, 29 C.F.R. Part 3), the Davis-Bacon and Related Acts (40 U.S.C. 3141-3148, 29 C.F.R. Parts 1,3, and 5), the Contract Work Hours and Safety Standards Act (40 U.S.C. 3701 et seq.), and all other applicable Federal, State, and local laws and regulations pertaining to labor standards, insofar as those acts apply to the performance of this Agreement. Responder is also responsible for ensuring that all subcontractors comply with the requirements of 29 CFR Part 5 and Part 30 and shall be in conformity with Executive Order 11246, entitled "Equal Employment Opportunity", Copeland "Anti-Kickback" Act, the Davis-Bacon and Related Acts (29 CFR Parts 1, 3 and 5), the Contract Work Hours and Safety Standards Act (40 U.S.C. 3701 et seq.), and all other applicable Federal, State, and local laws and regulations pertaining to labor standards, insofar as those acts apply to the performance of this Agreement.

67. PROCUREMENT STANDARDS - 2 C.F.R. §§ 200.317 – 200.326 & 2 C.F.R. PART 200, APPENDIX II

Two contract clauses were added to Appendix II of 2 C.F.R. Part 200. In addition to the previous contract clauses contained in the 2014 version of Appendix II of 2 C.F.R. Part 200, FEMA award recipient and subrecipient contracts and purchase orders must now include contract provisions for *Domestic Preferences for Procurements* (2 C.F.R. 200.322) and the *Prohibition on Contracting for Covered Telecommunications or Services* (2 C.F.R. 200.316)

2 C.F.R. § 200.317. Procurements by states.

When procuring property and services under a Federal award, a state must follow the same policies and procedures it uses for procurements from its non-Federal funds. The state will comply with §200.322 Procurement of recovered materials and ensure that every purchase order or other contract includes any clauses required by section §200.326 Contract provisions. All other non-Federal entities, including subrecipients of a state, will follow §§ 200.318 General procurement standards through 200.326 Contract provisions.

GENERAL PROVISIONS

REQUEST FOR PROPOSALS MENTAL HEALTH COURT PUBLIC DEFENDER'S OFFICE BUILDOUT GALVESTON COUNTY, TEXAS

69 FR 26280, May 11, 2004; 78 FR 78608, Dec. 26, 2013

2 C.F.R. § 200.318. General procurement standards.

(a) The non-Federal entity must use its own documented procurement procedures which reflect applicable State, local and tribal laws and regulations, provided that the procurements conform to applicable Federal law and the standards identified in this part.

(b) Non-Federal entities must maintain oversight to ensure that contractors perform in accordance with the terms, conditions, and specifications of their contracts or purchase orders.

(c)

(1) The non-Federal entity must maintain written standards of conduct covering conflicts of interest and governing the actions of its employees engaged in the selection, award and administration of contracts. No employee, officer, or agent may participate in the selection, award, or administration of a contract supported by a Federal award if he or she has a real or apparent conflict of interest. Such a conflict of interest would arise when the employee, officer, or agent, any member of his or her immediate family, his or her partner, or an organization which employs or is about to employ any of the parties indicated herein, has a financial or other interest in or a tangible personal benefit from a firm considered for a contract. The officers, employees, and agents of the non-Federal entity may neither solicit nor accept gratuities, favors, or anything of monetary value from contractors or parties to subcontracts. However, non-Federal entities may set standards for situations in which the financial interest is not substantial or the gift is an unsolicited item of nominal value. The standards of conduct must provide for disciplinary actions to be applied for violations of such standards by officers, employees, or agents of the non-Federal entity.

(2) If the non-Federal entity has a parent, affiliate, or subsidiary organization that is not a state, local government, or Indian tribe, the non-Federal entity must also maintain written standards of conduct covering organizational conflicts of interest. Organizational conflicts of interest means that because of relationships with a parent company, affiliate, or subsidiary organization, the non-Federal entity is unable or appears to be unable to be impartial in conducting a procurement action involving a related organization.

(d) The non-Federal entity's procedures must avoid acquisition of unnecessary or duplicative items. Consideration should be given to consolidating or breaking out procurements to obtain a more economical purchase. Where appropriate, an analysis will be made of lease versus purchase alternatives, and any other appropriate analysis to determine the most economical approach.

(e) To foster greater economy and efficiency, and in accordance with efforts to promote cost-effective use of shared services across the Federal Government, the non-Federal entity is encouraged to enter into state and local intergovernmental agreements or inter-entity agreements where appropriate for procurement or use of common or shared goods and services.

(f) The non-Federal entity is encouraged to use Federal excess and surplus property in lieu of purchasing new equipment and property whenever such use is feasible and reduces project costs.

GENERAL PROVISIONS

REQUEST FOR PROPOSALS MENTAL HEALTH COURT PUBLIC DEFENDER'S OFFICE BUILDOUT GALVESTON COUNTY, TEXAS

(g) The non-Federal entity is encouraged to use value engineering clauses in contracts for construction projects of sufficient size to offer reasonable opportunities for cost reductions. Value engineering is a systematic and creative analysis of each contract item or task to ensure that its essential function is provided at the overall lower cost.

(h) The non-Federal entity must award contracts only to responsible contractors possessing the ability to perform successfully under the terms and conditions of a proposed procurement. Consideration will be given to such matters as contractor integrity, compliance with public policy, record of past performance, and financial and technical resources. See also § 200.213 Suspension and debarment.

(i) The non-Federal entity must maintain records sufficient to detail the history of procurement. These records will include, but are not necessarily limited to the following: rationale for the method of procurement, selection of contract type, contractor selection or rejection, and the basis for the contract price.

(j)

(1) The non-Federal entity may use a time and materials type contract only after a determination that no other contract is suitable and if the contract includes a ceiling price that the contractor exceeds at its own risk. Time and materials type contract means a contract whose cost to a non-Federal entity is the sum of:

(i) The actual cost of materials; and

(ii) Direct labor hours charged at fixed hourly rates that reflect wages, general and administrative expenses, and profit.

(2) Since this formula generates an open-ended contract price, a time-and-materials contract provides no positive profit incentive to the contractor for cost control or labor efficiency. Therefore, each contract must set a ceiling price that the contractor exceeds at its own risk. Further, the non-Federal entity awarding such a contract must assert a high degree of oversight in order to obtain reasonable assurance that the contractor is using efficient methods and effective cost controls.

(k) The non-Federal entity alone must be responsible, in accordance with good administrative practice and sound business judgment, for the settlement of all contractual and administrative issues arising out of procurements. These issues include, but are not limited to, source evaluation, protests, disputes, and claims. These standards do not relieve the non-Federal entity of any contractual responsibilities under its contracts. The Federal awarding agency will not substitute its judgment for that of the non-Federal entity unless the matter is primarily a Federal concern. Violations of law will be referred to the local, state, or Federal authority having proper jurisdiction.

78 FR 78608, Dec. 26, 2013, as amended at 79 FR 75885, Dec. 19, 2014; 80 FR 43309, July 22, 2015; 80 FR 45395, July 30, 2015

GENERAL PROVISIONS

REQUEST FOR PROPOSALS MENTAL HEALTH COURT PUBLIC DEFENDER'S OFFICE BUILDOUT GALVESTON COUNTY, TEXAS

2 C.F.R. § 200.319. Competition.

(a) All procurement transactions must be conducted in a manner providing full and open competition consistent with the standards of this section. In order to ensure objective contractor performance and eliminate unfair competitive advantage, contractors that develop or draft specifications, requirements, statements of work, or invitations for RFPs or requests for proposals must be excluded from competing for such procurements. Some of the situations considered to be restrictive of competition include but are not limited to:

(1) Placing unreasonable requirements on firms in order for them to qualify to do business;

(2) Requiring unnecessary experience and excessive bonding;

(3) Noncompetitive pricing practices between firms or between affiliated companies;

(4) Noncompetitive contracts to consultants that are on retainer contracts;

(5) Organizational conflicts of interest;

(6) Specifying only a "brand name" product instead of allowing "an equal" product to be offered and describing the performance or other relevant requirements of the procurement; and

(7) Any arbitrary action in the procurement process.

(b) The non-Federal entity must conduct procurements in a manner that prohibits the use of statutorily or administratively imposed state, local, or tribal geographical preferences in the evaluation of RFPs or proposals, except in those cases where applicable Federal statutes expressly mandate or encourage geographic preference. Nothing in this section preempts state licensing laws. When contracting for architectural and engineering (A/E) services, geographic location may be a selection criterion provided its application leaves an appropriate number of qualified firms, given the nature and size of the project, to compete for the contract.

GENERAL PROVISIONS

REQUEST FOR PROPOSALS MENTAL HEALTH COURT PUBLIC DEFENDER'S OFFICE BUILDOUT GALVESTON COUNTY, TEXAS

(c) The non-Federal entity must have written procedures for procurement transactions. These procedures must ensure that all solicitations:

(1) Incorporate a clear and accurate description of the technical requirements for the material, product, or service to be procured. Such description must not, in competitive procurements, contain features which unduly restrict competition. The description may include a statement of the qualitative nature of the material, product or service to be procured and, when necessary, must set forth those minimum essential characteristics and standards to which it must conform if it is to satisfy its intended use. Detailed product specifications should be avoided if at all possible. When it is impractical or uneconomical to make a clear and accurate description of the technical requirements, a "brand name or equivalent" description may be used as a means to define the performance or other salient requirements of procurement. The specific features of the named brand which must be met by offers must be clearly stated; and

(2) Identify all requirements which the offerors must fulfill and all other factors to be used in evaluating RFPs or proposals.

(d) The non-Federal entity must ensure that all prequalified lists of persons, firms, or products which are used in acquiring goods and services are current and include enough qualified sources to ensure maximum open and free competition. Also, the non-Federal entity must not preclude potential Responders from qualifying during the solicitation period.

78 FR 78608, Dec. 26, 2013, as amended at 79 FR 75885, Dec. 19, 2014

2 C.F.R. § 200.320. Methods of procurement to be followed.

The non-Federal entity must use one of the following methods of procurement.

(a) Procurement by micro-purchases. Procurement by micro-purchase is the acquisition of supplies or services, the aggregate dollar amount of which does not exceed the micro-purchase threshold (§200.67 Micro-purchase). To the extent practicable, the non-Federal entity must distribute micro-purchases equitably among qualified suppliers. Micro-purchases may be awarded without soliciting competitive quotations if the non-Federal entity considers the price to be reasonable.

(b) Procurement by small purchase procedures. Small purchase procedures are those relatively simple and informal procurement methods for securing services, supplies, or other property that do not cost more than the Simplified Acquisition Threshold. If small purchase procedures are used, price or rate quotations must be obtained from an adequate number of qualified sources.

(c) Procurement by sealed RFPs (formal advertising). RFPs are publicly solicited and a firm fixed price contract (lump sum or unit price) is awarded to the responsible Responder whose RFP, conforming with all the material terms and conditions of the invitation for RFPs, is the lowest in price. The sealed RFP method is the preferred method for procuring construction, if the conditions in paragraph (c)(1) of this section apply.

(1) In order for sealed soliciting to be feasible, the following conditions should be present:

(i) A complete, adequate, and realistic specification or purchase description is available;

GENERAL PROVISIONS

REQUEST FOR PROPOSALS MENTAL HEALTH COURT PUBLIC DEFENDER'S OFFICE BUILDOUT GALVESTON COUNTY, TEXAS

(ii) Two or more responsible Responders are willing and able to compete effectively for the business; and

(iii) The procurement lends itself to a firm fixed price contract and the selection of the successful Responder can be made principally on the basis of price.

(2) If sealed RFPs are used, the following requirements apply:

(i) RFPs must be solicited from an adequate number of known suppliers, providing them sufficient response time prior to the date set for opening the RFPs, for local, and tribal governments, the invitation for RFPs must be publicly advertised;

(ii) The invitation for RFPs, which will include any specifications and pertinent attachments, must define the items or services in order for the Responder to properly respond;

(iii) All RFPs will be opened at the time and place prescribed in the invitation for RFPs, and for local and tribal governments, the RFPs must be opened publicly;

(iv) A firm fixed price contract award will be made in writing to the lowest responsive and responsible Responder. Where specified in solicitation documents, factors such as discounts, transportation cost, and life cycle costs must be considered in determining which RFP is lowest. Payment discounts will only be used to determine the low RFP when prior experience indicates that such discounts are usually taken advantage of; and

(v) Any or all RFPs may be rejected if there is a sound documented reason.

(d) Procurement by competitive proposals. The technique of competitive proposals is normally conducted with more than one source submitting an offer, and either a fixed price or cost-reimbursement type contract is awarded. It is generally used when conditions are not appropriate for the use of sealed RFPs. If this method is used, the following requirements apply:

(1) Requests for proposals must be publicized and identify all evaluation factors and their relative importance. Any response to publicized requests for proposals must be considered to the maximum extent practical;

(2) Proposals must be solicited from an adequate number of qualified sources;

(3) The non-Federal entity must have a written method for conducting technical evaluations of the proposals received and for selecting recipients;

(4) Contracts must be awarded to the responsible firm whose proposal is most advantageous to the program, with price and other factors considered; and

(5) The non-Federal entity may use competitive proposal procedures for Proposals-based procurement of architectural/engineering (A/E) professional services whereby competitors' Proposals are evaluated and the most qualified competitor is selected, subject to negotiation of fair and reasonable compensation. The method, where price is not used as a selection factor, can only be used in procurement of A/E professional services. It cannot be used to purchase other types of services though A/E firms are a potential source to perform the proposed effort.

(e) [Reserved]

GENERAL PROVISIONS

REQUEST FOR PROPOSALS MENTAL HEALTH COURT PUBLIC DEFENDER'S OFFICE BUILDOUT GALVESTON COUNTY, TEXAS

(f) Procurement by noncompetitive proposals. Procurement by noncompetitive proposals is procurement through solicitation of a proposal from only one source and may be used only when one or more of the following circumstances apply:

- (1) The item is available only from a single source;
- (2) The public exigency or emergency for the requirement will not permit a delay resulting from competitive solicitation;
- (3) The Federal awarding agency or pass-through entity expressly authorizes noncompetitive proposals in response to a written request from the non-Federal entity; or
- (4) After solicitation of a number of sources, competition is determined inadequate.

78 FR 78608, Dec. 26, 2013, as amended at 79 FR 75885, Dec. 19, 2014; 80 FR 54409, Sept. 10, 2015

2 C.F.R. § 200.321. Contracting with small and minority businesses, women's business enterprises, and labor surplus area firms.

(a) The non-Federal entity must take all necessary affirmative steps to assure that minority businesses, women's business enterprises, and labor surplus area firms are used when possible.

(b) Affirmative steps must include:

- (1) Placing qualified small and minority businesses and women's business enterprises on solicitation lists;
- (2) Assuring that small and minority businesses, and women's business enterprises are solicited whenever they are potential sources;
- (3) Dividing total requirements, when economically feasible, into smaller tasks or quantities to permit maximum participation by small and minority businesses, and women's business enterprises;
- (4) Establishing delivery schedules, where the requirement permits, which encourage participation by small and minority businesses, and women's business enterprises;
- (5) Using the services and assistance, as appropriate, of such organizations as the Small Business Administration and the Minority Business Development Agency of the Department of Commerce; and
- (6) Requiring the prime contractor, if subcontracts are to be let, to take the affirmative steps listed in paragraphs (1) through (5) of this section.

69 FR 26280, May 11, 2004; 78 FR 78608, Dec. 26, 2013, unless otherwise noted

2 C.F.R. § 200.322. Procurement of recovered materials.

A non-Federal entity that is a state agency or agency of a political subdivision of a state and its contractors must comply with section 6002 of the Solid Waste Disposal Act, as amended by the Resource Conservation and Recovery Act. The requirements of Section 6002 include procuring only items designated in guidelines of the Environmental Protection Agency (EPA) at 40 CFR

GENERAL PROVISIONS

REQUEST FOR PROPOSALS MENTAL HEALTH COURT PUBLIC DEFENDER'S OFFICE BUILDOUT GALVESTON COUNTY, TEXAS

part 247 that contain the highest percentage of recovered materials practicable, consistent with maintaining a satisfactory level of competition, where the purchase price of the item exceeds \$10,000 or the value of the quantity acquired during the preceding fiscal year exceeded \$10,000; procuring solid waste management services in a manner that maximizes energy and resource recovery; and establishing an affirmative procurement program for procurement of recovered materials identified in the EPA guidelines.

78 FR 78608, Dec. 26, 2013, as amended at 79 FR 75885, Dec. 19, 2014

2 C.F.R. § 200.323. Contract cost and price.

(a) The non-Federal entity must perform a cost or price analysis in connection with every procurement action in excess of the Simplified Acquisition Threshold including contract modifications. The method and degree of analysis is dependent on the facts surrounding the particular procurement situation, but as a starting point, the non-Federal entity must make independent estimates before receiving RFPs or proposals.

(b) The non-Federal entity must negotiate profit as a separate element of the price for each contract in which there is no price competition and in all cases where cost analysis is performed. To establish a fair and reasonable profit, consideration must be given to the complexity of the work to be performed, the risk borne by the contractor, the contractor's investment, the amount of subcontracting, the quality of its record of past performance, and industry profit rates in the surrounding geographical area for similar work.

(c) Costs or prices based on estimated costs for contracts under the Federal award are allowable only to the extent that costs incurred or cost estimates included in negotiated prices would be allowable for the non-Federal entity under Subpart E—Cost Principles of this part. The non-Federal entity may reference its own cost principles that comply with the Federal cost principles.

(d) The cost plus a percentage of cost and percentage of construction cost methods of contracting must not be used.

69 FR 26280, May 11, 2004; 78 FR 78608, Dec. 26, 2013, unless otherwise noted

2 C.F.R. § 200.324. Federal awarding agency or pass-through entity review.

(a) The non-Federal entity must make available, upon request of the Federal awarding agency or pass-through entity, technical specifications on proposed procurements where the Federal awarding agency or pass-through entity believes such review is needed to ensure that the item or service specified is the one being proposed for acquisition. This review generally will take place prior to the time the specification is incorporated into a solicitation document. However, if the non-Federal entity desires to have the review accomplished after a solicitation has been developed, the Federal awarding agency or pass-through entity may still review the specifications, with such review usually limited to the technical aspects of the proposed purchase.

(b) The non-Federal entity must make available upon request, for the Federal awarding agency or pass-through entity pre-procurement review, procurement documents, such as requests for proposals or invitations for RFPs, or independent cost estimates, when:

(1) The non-Federal entity's procurement procedures or operation fails to comply with the procurement standards in this part;

GENERAL PROVISIONS

REQUEST FOR PROPOSALS MENTAL HEALTH COURT PUBLIC DEFENDER'S OFFICE BUILDOUT GALVESTON COUNTY, TEXAS

- (2) The procurement is expected to exceed the Simplified Acquisition Threshold and is to be awarded without competition or only one RFP or offer is received in response to a solicitation;
 - (3) The procurement, which is expected to exceed the Simplified Acquisition Threshold, specifies a "brand name" product;
 - (4) The proposed contract is more than the Simplified Acquisition Threshold and is to be awarded to other than the apparent low Responder under a sealed RFP procurement; or
 - (5) A proposed contract modification changes the scope of a contract or increases the contract amount by more than the Simplified Acquisition Threshold.
- (c) The non-Federal entity is exempt from the pre-procurement review in paragraph (b) of this section if the Federal awarding agency or pass-through entity determines that its procurement systems comply with the standards of this part.
- (1) The non-Federal entity may request that its procurement system be reviewed by the Federal awarding agency or pass-through entity to determine whether its system meets these standards in order for its system to be certified. Generally, these reviews must occur where there is continuous high-dollar funding, and third party contracts are awarded on a regular basis;
 - (2) The non-Federal entity may self-certify its procurement system. Such self-certification must not limit the Federal awarding agency's right to survey the system. Under a self-certification procedure, the Federal awarding agency may rely on written assurances from the non-Federal entity that it is complying with these standards. The non-Federal entity must cite specific policies, procedures, regulations, or standards as being in compliance with these requirements and have its system available for review.

69 FR 26280, May 11, 2004; 78 FR 78608, Dec. 26, 2013, unless otherwise noted

2 C.F.R. § 200.325. Bonding requirements.

For construction or facility improvement contracts or subcontracts exceeding the Simplified Acquisition Threshold, the Federal awarding agency or pass-through entity may accept the bonding policy and requirements of the non-Federal entity provided that the Federal awarding agency or pass-through entity has made a determination that the Federal interest is adequately protected. If such a determination has not been made, the minimum requirements must be as follows:

- (a) A RFP guarantee from each Responder equivalent to five percent of the RFP price. The "RFP guarantee" must consist of a firm commitment such as a RFP bond, certified check, or other negotiable instrument accompanying a RFP as assurance that the Responder will, upon acceptance of the RFP, execute such contractual documents as may be required within the time specified.
- (b) A performance bond on the part of the contractor for 100 percent of the contract price. A "performance bond" is one executed in connection with a contract to secure fulfillment of all the contractor's obligations under such contract.
- (c) A payment bond on the part of the contractor for 100 percent of the contract price. A "payment bond" is one executed in connection with a contract to assure payment as required by law of all persons supplying labor and material in the execution of the work provided for in the contract.

69 FR 26280, May 11, 2004; 78FR 78608, Dec. 26, 2013, unless otherwise noted

2 C.F.R. § 200.326. Contract provisions.

GENERAL PROVISIONS

REQUEST FOR PROPOSALS MENTAL HEALTH COURT PUBLIC DEFENDER'S OFFICE BUILDOUT GALVESTON COUNTY, TEXAS

The non-Federal entity's contracts must contain the applicable provisions described in Appendix II to Part 200—Contract Provisions for non-Federal Entity Contracts Under Federal Awards.

69 FR 26280, May 11, 2004; 78 FR 78608, Dec. 26, 2013, unless otherwise note

2 C.F.R. Part, 200, Appendix II

In addition to other provisions required by the Federal agency or non-Federal entity, all contracts made by the non-Federal entity under the Federal award must contain provisions covering the following, as applicable.

(A) Contracts for more than the simplified acquisition threshold currently set at \$250,000, which is the inflation adjusted amount determined by the Civilian Agency Acquisition Council and the Defense Acquisition Regulations Council (Councils) as authorized by 41 U.S.C. 1908, must address administrative, contractual, or legal remedies in instances where contractors violate or breach contract terms, and provide for such sanctions and penalties as appropriate.

(B) All contracts in excess of \$10,000 must address termination for cause and for convenience by the non-Federal entity including the manner by which it will be affected and the basis for settlement.

(C) Equal Employment Opportunity. Except as otherwise provided under 41 CFR Part 60, all contracts that meet the definition of "federally assisted construction contract" in 41 CFR Part 60-1.3 must include the equal opportunity clause provided under 41 CFR 60-1.4(b), in accordance with Executive Order 11246, "Equal Employment Opportunity" (30 FR 12319, 12935, 3 CFR Part, 1964-1965 Comp., p. 339), as amended by Executive Order 11375, "Amending Executive Order 11246 Relating to Equal Employment Opportunity," and implementing regulations at 41 CFR part 60, "Office of Federal Contract Compliance Programs, Equal Employment Opportunity, Department of Labor."

(D) Davis-Bacon Act, as amended (40 U.S.C. 3141-3148). When required by Federal program legislation, all prime construction contracts in excess of \$2,000 awarded by non-Federal entities must include a provision for compliance with the Davis-Bacon Act (40 U.S.C. 3141-3144, and 3146-3148) as supplemented by Department of Labor regulations (29 CFR Part 5, "Labor Standards Provisions Applicable to Contracts Covering Federally Financed and Assisted Construction"). In accordance with the statute, contractors must be required to pay wages to laborers and mechanics at a rate not less than the prevailing wages specified in a wage determination made by the Secretary of Labor. In addition, contractors must be required to pay wages not less than once a week. The non-Federal entity must place a copy of the current prevailing wage determination issued by the Department of Labor in each solicitation. The decision to award a contract or subcontract must be conditioned upon the acceptance of the wage determination. The non-Federal entity must report all suspected or reported violations to the Federal awarding agency. The contracts must also include a provision for compliance with the Copeland "Anti-Kickback" Act (40 U.S.C. 3145), as supplemented by Department of Labor regulations (29 CFR Part 3, "Contractors and Subcontractors on Public Building or Public Work Financed in Whole or in Part by Loans or Grants from the United States"). The Act provides that each contractor or subrecipient must be prohibited from inducing, by any means, any person employed in the construction, completion, or repair of public work, to give up any part of the compensation to which he or she is otherwise entitled. The non-Federal entity must report all suspected or reported violations to the Federal awarding agency.

(E) Contract Work Hours and Safety Standards Act (40 U.S.C. 3701-3708). Where applicable, all contracts awarded by the non-Federal entity in excess of \$100,000 that involve the employment of mechanics or laborers must include a provision for compliance with 40 U.S.C. 3702 and 3704, as supplemented by Department of Labor regulations (29 CFR Part 5). Under 40 U.S.C. 3702 of the Act, each contractor must be required to compute the wages of every mechanic and laborer on the basis of a standard work week of 40 hours. Work in excess of the standard work week is permissible provided that the worker is compensated at a rate of not less than one and a half times the basic rate of pay for all hours worked in excess of 40 hours in the work week. The requirements of 40 U.S.C. 3704 are applicable to construction work and provide that no laborer or mechanic must be required to work in surroundings or under working conditions which are unsanitary, hazardous

GENERAL PROVISIONS

REQUEST FOR PROPOSALS MENTAL HEALTH COURT PUBLIC DEFENDER'S OFFICE BUILDOUT GALVESTON COUNTY, TEXAS

or dangerous. These requirements do not apply to the purchases of supplies or materials or articles ordinarily available on the open market, or contracts for transportation or transmission of intelligence.

(F) Rights to Inventions Made Under a Contract or Agreement. If the Federal award meets the definition of "funding agreement" under 37 CFR §401.2 (a) and the recipient or subrecipient wishes to enter into a contract with a small business firm or nonprofit organization regarding the substitution of parties, assignment or performance of experimental, developmental, or research work under that "funding agreement," the recipient or subrecipient must comply with the requirements of 37 CFR Part 401, "Rights to Inventions Made by Nonprofit Organizations and Small Business Firms Under Government Grants, Contracts and Cooperative Agreements," and any implementing regulations issued by the awarding agency.

(G) Clean Air Act (42 U.S.C. 7401-7671q.) and the Federal Water Pollution Control Act (33 U.S.C. 1251-1387), as amended—Contracts and subgrants of amounts in excess of \$150,000 must contain a provision that requires the non-Federal award to agree to comply with all applicable standards, orders or regulations issued pursuant to the Clean Air Act (42 U.S.C. 7401-7671q) and the Federal Water Pollution Control Act as amended (33 U.S.C. 1251-1387). Violations must be reported to the Federal awarding agency and the Regional Office of the Environmental Protection Agency (EPA).

(H) Debarment and Suspension (Executive Orders 12549 and 12689)—A contract award (see 2 CFR 180.220) must not be made to parties listed on the governmentwide exclusions in the System for Award Management (SAM), in accordance with the OMB guidelines at 2 CFR 180 that implement Executive Orders 12549 (3 CFR part 1986 Comp., p. 189) and 12689 (3 CFR part 1989 Comp., p. 235), "Debarment and Suspension." SAM Exclusions contains the names of parties debarred, suspended, or otherwise excluded by agencies, as well as parties declared ineligible under statutory or regulatory authority other than Executive Order 12549.

(I) Byrd Anti-Lobbying Amendment (31 U.S.C. 1352)—Contractors that apply or RFP for an award exceeding \$100,000 must file the required certification. Each tier certifies to the tier above that it will not and has not used Federal appropriated funds to pay any person or organization for influencing or attempting to influence an officer or employee of any agency, a member of Congress, officer or employee of Congress, or an employee of a member of Congress in connection with obtaining any Federal contract, grant or any other award covered by 31 U.S.C. 1352. Each tier must also disclose any lobbying with non-Federal funds that takes place in connection with obtaining any Federal award. Such disclosures are forwarded from tier to tier up to the non-Federal award.

(J) See §200.322 Procurement of recovered materials.

78 FR 78608, Dec. 26, 2013, as amended at 79 FR 75888, Dec. 19, 2014

DOMESTIC PREFERENCES FOR PROCUREMENTS (*All State and non-State entity purchase orders must adhere to the following*)

§ 200.322 Domestic preferences for procurements.

(a) As appropriate and to the extent consistent with law, the non-Federal entity should, to the greatest extent practicable under a Federal award, provide a preference for the purchase, acquisition, or use of goods, products, or materials produced in the United States (including but not limited to iron, aluminum, steel, cement, and other manufactured products). The requirements of this section must be included in all subawards including all contracts and purchase orders for work or products under this award.

(b) For purposes of this section:

(1) "Produced in the United States" means, for iron and steel products, that all manufacturing processes, from the initial melting stage through the application of coatings, occurred in the United States.

GENERAL PROVISIONS

REQUEST FOR PROPOSALS MENTAL HEALTH COURT PUBLIC DEFENDER'S OFFICE BUILDOUT GALVESTON COUNTY, TEXAS

(2) "Manufactured products" means items and construction materials composed in whole or in part of non-ferrous metals such as aluminum; plastics and polymer-based products such as polyvinyl chloride pipe; aggregates such as concrete; glass, including optical fiber; and lumber.

PROHIBITION ON CONTRACTING FOR COVERED TELECOMMUNICATIONS OR SERVICES *(Effective August 13, 2020 for new, extended, or renewed procurements under all open FEMA awards)*

§ 200.216 Prohibition on certain telecommunications and video surveillance services or equipment.

(a) Recipients and subrecipients are prohibited from obligating or expending loan or grant funds to:

(1) Procure or obtain;

(2) Extend or renew a contract to procure or obtain; or

(3) Enter into a contract (or extend or renew a contract) to procure or obtain equipment, services, or systems that uses covered telecommunications equipment or services as a substantial or essential component of any system, or as critical technology as part of any system. As described in Public Law 115-232, section 889, covered telecommunications equipment is telecommunications equipment produced by Huawei Technologies Company or ZTE Corporation (or any subsidiary or affiliate of such entities).

(i) For the purpose of public safety, security of government facilities, physical security surveillance of critical infrastructure, and other national security purposes, video surveillance and telecommunications equipment produced by Hytera Communications Corporation, Hangzhou Hikvision Digital Technology Company, or Dahua Technology Company (or any subsidiary or affiliate of such entities).

(ii) Telecommunications or video surveillance services provided by such entities or using such equipment.

(iii) Telecommunications or video surveillance equipment or services produced or provided by an entity that the Secretary of Defense, in consultation with the Director of the National Intelligence or the Director of the Federal Bureau of Investigation, reasonably believes to be an entity owned or controlled by, or otherwise connected to, the government of a covered foreign country.

(b) In implementing the prohibition under Public Law 115-232, section 889, subsection (f), paragraph

(1), heads of executive agencies administering loan, grant, or subsidy programs shall prioritize available funding and technical support to assist affected businesses, institutions and organizations as is reasonably necessary for those affected entities to transition from covered communications equipment and services, to procure replacement equipment and services, and to ensure that communications service to users and customers is sustained.

(c) See Public Law 115-232, section 889 for additional information.

(d) See also § 200.471.

GENERAL PROVISIONS

REQUEST FOR PROPOSALS MENTAL HEALTH COURT PUBLIC DEFENDER'S OFFICE BUILDOUT GALVESTON COUNTY, TEXAS

68. PROCUREMENT LAWS

- a. Responder shall comply with all applicable local, State, and Federal laws, rules, and regulations.
- b. If this contract is made pursuant to a federal award, then Contractor acknowledges that the contract is subject, without limitation, to applicable provisions within 2 C.F.R. Part 200, Uniform Administrative Requirements, Cost Principles, and Audit Requirements for Federal Awards. Contractor shall comply with applicable provisions within 2 C.F.R., Sections 200.319 through 200.326, including but not limited to the following:
 - 1.) **Equal Employment Opportunity**, 41 C.F.R. Part 60-1.4(b) (applicable to federally assisted construction contracts).
 - (a) During the performance of this contract, the contractor agrees as follows:
 - (1) The contractor will not discriminate against any employee or applicant for employment because of race, color, religion, sex, national original, disability, or veteran status. The contractor will take affirmative action to ensure that applicants are employed, and that employees are treated during employment, without regard to their race, color, religion, sex, national original, disability or veteran status. Such action shall include, but not be limited to the following: employment, upgrading, demotion, or transfer; recruitment or recruitment advertising; layoff or termination; rates of pay or other forms of compensation; and selection for training, including apprenticeship. The contractor agrees to post in conspicuous places, available to employees and applicants for employment, notices to be provided setting forth the provisions of this nondiscrimination clause.
 - (2) The contractor will, in all solicitations or advertisements for employees placed by or on behalf of contractor, state that all qualified applicants will receive consideration for employment without regard to race, color, religion, sex, national original, disability, or veteran status.
 - (3) The contractor will send to each labor union or representative of workers with which he has a collective bargaining agreement or other contract or understanding, a notice to be provided advising the said labor union or workers' representatives of the contractor's commitments under this section and shall post copies of the notice in conspicuous places available to employees and applicants for employment.
 - (4) The contractor will comply with all provisions of Executive Order 11246 of September 24, 1965, and by rules, regulations, and relevant orders of the Secretary of Labor.
 - (5) The contractor will furnish all information and reports required by Executive Order 11246 of September 24, 1965, and by rules, regulations, and orders of the Secretary of Labor, or pursuant thereto, and will permit access to contractor's books, records, and accounts by the administering agency and the Secretary of Labor for purposes of investigation to ascertain compliance with such rules, regulations, and orders.
 - (6) In the event of the contractor's noncompliance with the nondiscrimination clauses of this contract or with any of the said rules, regulations, or orders, this contract may be cancelled, terminated, or suspended in whole or in part and the contractor may be declared ineligible for further Government contracts or federally assisted construction contracts in accordance with procedures authorized in Executive Order 11246 of September 24, 1965, and such other sanctions as may be imposed and remedies invoked as provided in Executive Order 11246 of September 24, 1965, or by rule, regulation, or order of the Secretary of Labor, or as otherwise provided by law.
 - (7) The contractor will include the portion of the sentence immediately preceding paragraph (1) and the provisions of paragraphs (1) through (7) in every subcontract or purchase order unless exempted by rules, regulations, or orders of the Secretary of Labor issued pursuant to section 204 of Executive Order 11246 of September 24, 1965, so that such provisions will be binding upon each subcontractor or vendor. The contractor will take

GENERAL PROVISIONS

REQUEST FOR PROPOSALS MENTAL HEALTH COURT PUBLIC DEFENDER'S OFFICE BUILDOUT GALVESTON COUNTY, TEXAS

such action with respect to any subcontract or purchase order as the administering agency may direct as a means of enforcing such provisions, including sanctions for noncompliance: Provided, however, that in the event a contractor becomes involved in, or is threatened with, litigation with a subcontractor or vendor as a result of such direction by the administering agency, the contractor may request the United States to enter into such litigation to protect the interests of the United States.

- 2.) **Small and minority business, women's business enterprises, and labor surplus area firms (2 C.F.R. § 200.321).** The County is required to take affirmative steps to assure that minority businesses, women's business enterprises, and labor surplus area firms are used when possible. This includes requiring the prime contractor, if subcontracts are to be let in the performance of this contract, to itself take affirmative steps in letting the subcontract. Accordingly, if subcontracts are to be let in the performance of this contract, the contractor must take affirmative steps in the letting of the subcontract(s), which must include:
- (a) placing qualified small and minority businesses and women's business enterprises on solicitation lists;
 - (b) assuring that small and minority businesses, and women's business enterprises are solicited whenever they are potential sources;
 - (c) dividing total requirements, when economically feasible, into smaller tasks or quantities to permit maximum participation by small and minority businesses, and women's business enterprises; and
 - (d) using the services and assistance, as appropriate, of such organizations as the Small Business Administration and the Minority Business Development Agency of the Department of Commerce.

In accordance with FEMA procurement guidance:

A small business is a business that is independently owned and operated, not dominant in the field of operation in which it is responding on Galveston County contracts and qualified as a small business under the Small Business Administration criteria and size standards at 13 C.F.R. Part 121.

A women's business enterprise is a business enterprise that is: (a) at least 51 percent owned by one or more women or, in the case of a publicly owned business, at least 51 percent of the stock is owned by one or more women; and (b) whose management and daily operations are controlled by one or more women.

A minority business is a business that is (a) at least 51 percent owned by one or more minority group members or, in the case of a publicly owned business, at least 51 percent of the stock is owned by one or more minority group members; and (b) whose management and daily operations are controlled by one or more minority group members.

- 3.) **Davis-Bacon Act as amended (40 U.S.C. 3141-3148).** When required by Federal program legislation, all prime construction contracts in excess of \$2,000 must include a provision for compliance with the Davis-Bacon Act as supplemented by the Department of Labor regulations (29 C.F.R. Part 5, "Labor Standards Provisions Applicable to Contracts Covering Federally Financed and Assisted Construction"). In accordance with the statute, contractor must be required to pay wages to laborers and mechanics at a rate not less than the prevailing wages specified in a wage determination made by the Secretary of Labor. In addition, contractors must be required to pay wages not less than once a week. The non-Federal entity (the County) must place a copy of the current prevailing wage determination issued by the Department of Labor in each solicitation. The decision to award a contract or subcontract must be condition upon the acceptance of the wage determination. The non-Federal entity must report all suspected or reported violations to the Federal awarding agency. The contract must also include a provision for compliance with the Copeland Anti-Kickback Act (40 U.S.C. § 3145) as supplemented by the Department of Labor regulations (29 C.F.R. Part 3, "Contractors and Subcontractors on Public Building or Public Work Financed in Whole or in Part by Loans or Grants from the United States").
- 4.) **Compliance with the Copeland "Anti-Kickback" Act.** Contractor is prohibited from inducing, by any means, any person employed in the construction, completion, or repair of public work, to give up any part of the compensation to

GENERAL PROVISIONS

REQUEST FOR PROPOSALS MENTAL HEALTH COURT PUBLIC DEFENDER'S OFFICE BUILDOUT GALVESTON COUNTY, TEXAS

which the person is otherwise entitled. The non-Federal entity must report all suspected or reported violations to the Federal awarding agency. "Whoever, by force, intimidation, or threat of procuring dismissal from employment, or by any other manner whatsoever induces any person employed in the construction, prosecution, completion or repair of any public building, public work, or building or work financed in whole or in part by loans or grants from the United States, to give up any part of the compensation to which he is entitled under his contract of employment, shall be fined under this title [Title 18, U.S.C.] or imprisoned not more than five years, or both." 18 U.S.C. § 874.

- (a) Contractor shall comply with 18 U.S.C. § 874, 40 U.S.C. § 3145, and the requirements of 29 C.F.R. Part 3 as may be applicable, which are incorporated by reference into this contract.
- (b) The contractor or subcontractor shall insert in any subcontracts the clause above and such other clauses as the Federal awarding agency may be appropriate instructions require, and also a clause requiring the subcontractors to include these clauses in any lower tier subcontracts. The prime contractor shall be responsible for the compliance by any subcontractor or lower tier subcontractor with all of these contract clauses.
- (c) Breach. A breach of the contract clause above may be grounds for termination of the contract, and for debarment as a contractor and subcontractor as provided in 29 C.F.R. § 5.12.

5.) **Contract Work Hours and Safety Standards Act.**

- (a) Where applicable, all contracts awarded by the County in excess of \$100,000 that involve the employment of mechanics or laborers must include a provision for compliance with 40 U.S.C. §§ 3702 and 3704, as supplemented by the Department of Labor regulations at 29 C.F.R. Part 5. Under 40 U.S.C. § 3702 of the Contract Work Hours and Safety Standards Act, each contractor must be required to compute the wages of every mechanic and laborer on the basis of a standard work week of 40 hours. Work in excess of the standard work week is permissible provided that the worker is compensated at a rate of not less than one and a half times the basic rate of pay for all hours worked in excess of 40 hours in the work week. The requirements of 40 U.S.S. 3704 are applicable to construction work and provide that no laborer or mechanic must be required to work in surroundings or under working conditions which are unsanitary, hazardous or dangerous. These requirements do not apply to the purchase of supplies or material or articles ordinarily available on the open market, or contractors for transportation or transmission of intelligence.
- (b) **Compliance with the Contract Work Hours and Safety Standards Act.**
 - (1) **Overtime requirements.** No contractor or subcontractor contracting for any part of the contract work which may require or involve the employment of laborers or mechanics shall require or permit any such laborer or mechanic in any workweek in which he or she is employed on such work to work in excess of forty hours in such workweek unless such laborer or mechanic receives compensation at a rate not less than one and one-half times the basic rate of pay for all hours worked in excess of forty hours in such workweek.
 - (2) **Violation; liability for unpaid wages; liquidated damages.** In the event of any violation of the clause set forth in paragraph (1) of this subsection the contractor and any subcontractor responsible therefor shall be liable for the unpaid wages. In addition, such contractor and subcontractor shall be liable to the United States (in the case of work done under contract for the District of Columbia or a territory, to such District or to such territory), for liquidated damages. Such liquidated damages shall be computed with respect to each individual laborer or mechanic, including watchmen and guards, employed in violation of the clause set forth in paragraph (1) of this subsection, in the sum of \$10 for each calendar day on which such individual was required or permitted to work in excess of the standard work week of forty hours without payment of the overtime wages required by the clause set forth in paragraph (1) of this subsection.

GENERAL PROVISIONS

REQUEST FOR PROPOSALS MENTAL HEALTH COURT PUBLIC DEFENDER'S OFFICE BUILDOUT GALVESTON COUNTY, TEXAS

- (3) Withholding for unpaid wages and liquidated damages. The awarding Federal agency, State agency, or the County shall upon its own action or upon written request of an authorized representative of the Department of Labor withhold or cause to be withheld, from any moneys payable on account of work performed by the contractor or subcontractor under any such contract or any other Federal contract with the same prime contractor, or any other federally-assisted contract subject to the Contract Work Hours and Safety Standards Act, which is held by the same prime contractor, such sums as may be determined to be necessary to satisfy any liabilities of such contractor or subcontractor for unpaid wages and liquidated damages as provided in the clause set forth in paragraph (2) of this subsection.
- (4) Subcontracts. The contractor or subcontractor shall insert in any subcontracts the clauses set forth in paragraph (1) through (4) of this subsection and also a clause requiring the subcontractors to include these clauses in any lower tier subcontracts. The prime contractor shall be responsible for compliance by any subcontractor or lower tier subcontractor with the clauses set forth in paragraphs (1) through (4) of this subsection.
- 6.) **Rights to Inventions Made Under a Contractor Agreement.**
- (a) If the Federal award meets the definition of "funding agreement" under 37 C.F.R. § 401.2(a) and the recipient or subrecipient wishes to enter into a contract with a small business firm or nonprofit organization regarding the substitution of parties, assignment or performance of experimental, developmental, or research work under the "funding agreement," the recipient or subrecipient must comply with the requirements of 37 C.F.R. Part 401, "Rights to Inventions Made by Nonprofit Organizations and Small Business Firms Under Government Grants, Contracts and Cooperative Agreements," and any implementing regulations issued by the awarding agency.
- (b) Stafford Act Disaster Grants. This requirement does not apply to Public Assistance, Hazard Mitigation Grant Program, Crisis Counseling Assistance and Training Grant program, Disaster Case Management Grant Program, and Federal Assistance to Individuals and Households – Other Needs Assistance Grant Program, as FEMA awards under these programs do not meet the definition of "funding agreement."
- (c) The regulations and 37 C.F.R. § 401.2(a) currently defines "funding agreement" as any contract, grant, or cooperative agreement entered into between any Federal agency, other than the Tennessee Valley Authority, and any contractor for the performance of experimental, developmental, or research work funded in whole or in part by the Federal government. This term also includes any assignment, substitution of parties, or subcontract of any type entered into for the performance of experimental, developmental, or research work under a funding agreement as defined in the first sentence of this paragraph.
- 7.) **Clean Air Act (42 U.S.C. §§ 7401 – 7671q) and the Federal Water Pollution Control Act 933 U.S.C. §§ 1251-1387), as amended.**
- (a) The contractor agrees to comply with all applicable standards, orders or regulations issued pursuant to the Clean Air Act, as amended, 42 U.S.C. § 7401, et seq., and agrees to comply with all applicable standards, orders, or regulations issued pursuant to the Federal Water Pollution Contract Act, as amended, 33 U.S. C. § 1251, et seq.
- (b) The contractor agrees to report each violation of the Clean Air Act and/or the Federal Water Pollution Control Act to the Federal awarding agency, the State agency administering the grant, and the Regional Office of the Environmental Protection Agency (EPA) and understands and agrees that the Federal awarding agency, the State agency, and the EPA will, in turn, report each violation as required to assure notification to Galveston County, the Federal Emergency Management Agency, and the appropriate EPA Regional Office.
- 8.) **Debarment and Suspension (Executive Orders 12549 and 12689).** A contract award must not be made to parties listed on the government-wide exclusions in the System for Award Management (SAM), in accordance with the OMB guidelines at 2 C.F.R. Part 180 that implement Executive Orders 12549 and 12689. The Contractor is required to

GENERAL PROVISIONS

REQUEST FOR PROPOSALS MENTAL HEALTH COURT PUBLIC DEFENDER'S OFFICE BUILDOUT GALVESTON COUNTY, TEXAS

verify that none of the contractor, its principals (defined at 2 C.F.R. § 180.995), or its affiliates (defined at 2 C.F.R. § 180.905) are excluded (defined at 2 C.F.R. §180.940) or disqualified (defined at 2 C.F.R. § 180.935).

Contractor must comply with 2 C.F.R. Part 180, Subpart C and 2 C.F.R. Part 3000, Subpart C, and must include a requirement to comply with these regulations in any lower tier covered transaction it enters into. Responder agrees to comply with the requirements of 2 C.F.R. Part 180, Subpart C, and 2 C.F.R. Part 3000, Subpart C, while this offer is valid and through the period of any contract that may arise from this offer. The Responder further agrees to include a provision requiring such compliance in its lower tier covered transactions.

9.) **Domestic Preferences for Procurements (2 C.F.R. § 200.323)**

(a) As appropriate and to the extent consistent with law, the non-Federal entity should, to the greatest extent practicable under a Federal award, provide a preference for the purchase, acquisition, or use of goods, products, or materials produced in the United States (including but not limited to iron, aluminum, steel, cement, and other manufactured products). The requirements of this section must be included in all subawards including all contracts and purchase orders for work or products under this award.

(c) For purposes of this section:

- (1) "Produced in the United States" means, for iron and steel products, that all manufacturing processes, from the initial melting stage through the application of coatings, occurred in the United States.
- (2) "Manufactured products" means items and construction materials composed in whole or in part of non-ferrous metals such as aluminum; plastics and polymer-based products such as polyvinyl chloride pipe; aggregates such as concrete; glass, including optical fiber; and lumber.

10.) **Prohibition on Certain Telecommunications and Video Surveillance Services or Equipment.
(2 C.F.R. § 200.216)**

(a) Recipients and subrecipients are prohibited from obligating or expending loan or grant funds to:

- (1) Procure or obtain;
- (2) Extend or renew a contract to procure or obtain; or
- (2) Enter into a contract (or extend or renew a contract) to procure or obtain equipment, services, or systems that uses covered telecommunications equipment or services as a substantial or essential component of any system, or as critical technology as part of any system.

As described in Public Law 115-232, section 889, covered telecommunications equipment is telecommunications equipment produced by Huawei Technologies Company or ZTE Corporation (or any subsidiary or affiliate of such entities).

(i) For the purpose of public safety, security of government facilities, physical security surveillance of critical infrastructure, and other national security purposes, video surveillance and telecommunications equipment produced by Hytera Communications Corporation, Hangzhou Hikvision Digital Technology Company, or Dahua Technology Company (or any subsidiary or affiliate of such entities).

(ii) Telecommunications or video surveillance services provided by such entities or using such equipment.

GENERAL PROVISIONS

REQUEST FOR PROPOSALS MENTAL HEALTH COURT PUBLIC DEFENDER'S OFFICE BUILDOUT GALVESTON COUNTY, TEXAS

(iii) Telecommunications or video surveillance equipment or services produced or provided by an entity that the Secretary of Defense, in consultation with the Director of the National Intelligence or the Director of the Federal Bureau of Investigation, reasonably believes to be an entity owned or controlled by, or otherwise connected to, the government of a covered foreign country.

(b) In implementing the prohibition under Public Law 115-232, section 889 of the John S. McCain National Defense Authorization Act for Fiscal Year 2019 (FY 2019 NDAA), Pub. L. No. 115-232 (2018) and 2 C.F.R. 200.216, 200.327, 200.471, and Appendix II to C.F.R. Part 200, subsection (f), paragraph (1), heads of executive agencies administering loan, grant, or subsidy programs shall prioritize available funding and technical support to assist affected businesses, institutions and organizations as is reasonably necessary for those affected entities to transition from covered communications equipment and services, to procure replacement equipment and services, and to ensure that communications service to users and customers is sustained.

(c) See Public Law 115-232, section 889 for additional information.

(d) See also § 200.471.

11.) Procurement of Recovered Materials (2 C.F.R. § 200.323)

(a.) A non-Federal entity that is a State agency or agency of a political subdivision of the State and its contractors must comply with Section 6002 of the Solid Waste Disposal Act, Public Law No. 89-272 (1965) (codified as amended by the Resource Conservation and Recovery Act at 42 U.S.C. § 6962).

The requirements of Section 6002 include procuring only items designated in guidelines of the Environmental Protection Agency (EPA) at 40 CFR part 247 that contain the highest percentage of recovered materials practicable, consistent with maintaining a satisfactory level of competition, where the purchase price of the item exceeds \$10,000 or the value of the quantity acquired during the preceding fiscal year exceeded \$10,000; procuring solid waste management services in a manner that maximizes energy and resource recovery; and establishing an affirmative procurement program for procurement of recovered materials identified in the EPA guidelines.

(b.) In the performance of this contract, the contractor shall make maximum use of products containing recovered materials that are EPA-designated items unless the product cannot be acquired:

- (1) Competitively within a timeframe providing for compliance with the contract performance schedule;
- (2) Meeting contract performance requirements; or
- (3) At a reasonable price.

(d) Information about this requirement is available at EPA's Comprehensive Procurement Guidelines website, <http://www.epa.gov/cpg/>. The list of EPA-designated items is available at <https://www.epa.gov/cpg/products.htm>.

In the event of any discrepancy between the provisions in this Section 63 of General Provisions and provisions on the same subject elsewhere within this procurement, the most stringent shall control.

69. SECTION 3 CLAUSE (§ 135.38) – HOUSING AND URBAN DEVELOPMENT (HUD)

GENERAL PROVISIONS

REQUEST FOR PROPOSALS MENTAL HEALTH COURT PUBLIC DEFENDER'S OFFICE BUILDOUT GALVESTON COUNTY, TEXAS

SECTION 3 ACT OF 1968 (12 U.S.C. 1701u and 24 CFR Part 135)

DISCLAIMER: THIS CONTRACT [IS NOT] HUD-FUNDED AND THEREFORE SECTION 3 [DOES NOT] APPLY TO THIS CONTRACT.

For any HUD-funded contract with a value in excess of \$100,000, Contractor and subcontractors must comply with the Section 3 Act of 1968. The purpose of Section 3 is to ensure that employment and other economic opportunities generated by certain HUD financial assistance shall, to the greatest extent feasible, and consistent with existing Federal, State and local laws and regulations, be directed to low- and very low-income persons, particularly those who are recipients of government assistance for housing, and to business concerns which provide economic opportunities to low- and very low-income persons.

Section 3 is triggered when the normal completion of construction and rehabilitation projects creates the need for new employment, contracting, or training opportunities.

For any Section 3 Covered Contracts, Contractor and subcontractors must comply with all provisions of the Section 3 Act of 1968, contained under 24 CFR 135. Contractor and subcontractors must include the Section 3 Clause in its entirety, in every subcontract subject to compliance with regulations in 24 CFR 135.

Contractor and subcontractors must assure that to the greatest extent feasible, contracts for work to be performed in connection with the project are awarded to Section 3 Business Concerns. Contractor and subcontractors must post all new hire opportunities with the local Workforce Solutions Center and/or Work-in-Texas, in accordance with 24 CFR 135. The minimum numeric goals for Section 3 utilization are:

- 30 percent of total number of new hires are Section 3 Residents (i.e. 1 out of 3 new hires); 10 percent of all awarded construction contracts are awarded to Section 3 Business Concerns;
- 3 percent of all awarded non-construction contracts are awarded to Section 3 Business Concerns.

A. The work to be performed under this contract is subject to the requirements of section 3 of the Housing and Urban Development Act of 1968, as amended, 12 U.S.C. 1701u (section 3). The purpose of section 3 is to ensure that employment and other economic opportunities generated by HUD assistance or HUD-assisted projects covered by section 3, shall, to the greatest extent feasible, be directed to low- and very low-income persons, particularly persons who are recipients of HUD assistance for housing.

B. The parties to this contract agree to comply with HUD's regulations in 24 CFR part 135, which implement section 3. As evidenced by their execution of this contract, the parties to this contract certify that they are under no contractual or other impediment that would prevent them from complying with the part 135 regulations.

C. The contractor agrees to send to each labor organization or representative of workers with which the contractor has a collective bargaining agreement or other understanding, if any, a notice advising the labor organization or workers' representative of the contractor's commitments under this section 3 clause, and will post copies of the notice in conspicuous places at the work site where both employees and applicants for training and employment positions can see the notice. The notice shall describe the section 3 preference, shall set forth minimum number and job titles subject to hire, availability of apprenticeship and training positions, the Proposals for each; and the name and location of the person(s) taking applications for each of the positions; and the anticipated date the work shall begin.

D. The contractor agrees to include this section 3 clause in every subcontract subject to compliance with regulations in 24 CFR part 135, and agrees to take appropriate action, as provided in an applicable provision

GENERAL PROVISIONS

REQUEST FOR PROPOSALS MENTAL HEALTH COURT PUBLIC DEFENDER'S OFFICE BUILDOUT GALVESTON COUNTY, TEXAS

of the subcontract or in this section 3 clause, upon a finding that the subcontractor is in violation of the regulations in 24 CFR part 135. The contractor will not subcontract with any subcontractor where the contractor has notice or knowledge that the subcontractor has been found in violation of the regulations in 24 CFR part 135.

E. The contractor will certify that any vacant employment positions, including training positions, that are filled (1) after the contractor is selected but before the contract is executed, and (2) with persons other than those to whom the regulations of 24 CFR part 135 require employment opportunities to be directed, were not filled to circumvent the contractor's obligations under 24 CFR part 135.

F. Noncompliance with HUD's regulations in 24 CFR part 135 may result in sanctions, termination of this contract for default, and debarment or suspension from future HUD assisted contracts.

G. With respect to work performed in connection with section 3 covered Indian housing assistance, section 7(b) of the Indian Self-Determination and Education Assistance Act (25 U.S.C. 450e) also applies to the work to be performed under this contract. Section 7(b) requires that to the greatest extent feasible (i) preference and opportunities for training and employment shall be given to Indians, and (ii) preference in the award of contracts and sub contracts shall be given to Indian organizations and Indian-owned Economic Enterprises. Parties to this contract that are subject to the provisions of section 3 and section 7(b) agree to comply with section 3 to the maximum extent feasible, but not in derogation of compliance with section

70. REQUIRED CONTRACT PROVISIONS

The Part 200 Uniform Requirements require that non-Federal entities' contracts contain the applicable provisions described in Appendix II to Part 200 — "Contract Provisions for Non-Federal Entity Contracts Under Federal Awards." Violations of law will be referred to the proper authority in the applicable jurisdiction. All Prime Contractors awarded contracts by Galveston County which are federally funded, in whole or in part, are required to comply with the provisions below. Additionally, Prime Contractors with Galveston County are required to include the provisions below in any contracts executed with subcontractors performing the scope of work and shall pass these requirements on to its subcontractors and third-party contractors, as applicable. In addition to other provisions required by the relevant Federal agency, State of Texas, or Galveston County, all contracts made by Galveston County under the Federal award shall contain provisions covering the following, as applicable.

ACCESS TO RECORDS & RECORD RETENTION (2 CFR 200.336)

Contractor must provide Galveston County, the State of Texas, the Texas General Land Office (GLO), the U.S. Department of Housing and Urban Development (HUD), the FEMA Administrator, the Inspectors General, the Comptroller General of the United States, or any of their pass-through entities or authorized representatives access to any books, documents, papers, and records of the Contractor and its subcontractors which are directly pertinent to this contract/project for the purposes of making/responding to audits, examinations, excerpts, and transcriptions. The right also includes timely and reasonable access to the Contractor's personnel for the purpose of interview and discussion related to such documents. Contractor must keep records within Galveston County or note in RFP that records will be available within the boundaries of Galveston County to those representatives within twenty-four (24) hours of request by the County. Contractor must maintain all records pertaining to the project for seven (7) years after receiving final payment and after all other pending matters have been closed.

ACCESSIBILITY (24 CFR 570.614) & SECTION 504 (29 U.S.C. Section 794 and 24 CFR Parts 8-9)

Contractor shall comply with all federal, state and local laws and regulations which prohibit recipients of federal funding from discriminating against individuals with disabilities. Applicable laws and regulations with which Contractor shall

GENERAL PROVISIONS

REQUEST FOR PROPOSALS MENTAL HEALTH COURT PUBLIC DEFENDER'S OFFICE BUILDOUT GALVESTON COUNTY, TEXAS

comply shall include, but are not limited to, the following: Section 504 of the Rehabilitation Act of 1973 (29 U.S.C. Section 794) (24 CFR Parts 8-9); Title II of the Americans with Disabilities Act of 1990; the Architectural Barriers Act of 1968 (42 U.S.C. 4151-4157); the Uniform Federal Accessibility Standards (Appendix A to 24 CFR Part 40 and Appendix A to 41 CFR Part 101-19, subpart 101-19.6); the Americans with Disabilities Act (42 U.S.C. 12131; 47 U.S.C. 155, 201, 218, and 225); Texas Administrative Code, Title 10, Chapter 60, Subchapter (B) the Texas Architectural Barriers Act (TABA); the Architectural Barriers (AB) Rules; and the Texas Accessibility Standards (TAS).

BYRD ANTI-LOBBYING AGREEMENT (2 CFR 200 APPENDIX II (J) AND 24 CFR 570.303)

Pursuant to 31 U.S.C.A. § 1352 (2003), if at any time during the contract term funding to contract exceeds \$100,000.00, the Contractor shall file with the County the Federal Standard Form LLL titled "Disclosure Form to Report Lobbying." Each tier certifies to the tier above that it will not and has not used Federal appropriated funds to pay any person or organization for influencing or attempting to influence an officer or employee of any agency, a member of Congress, officer or employee of Congress, or an employee of a member of Congress in connection with obtaining any Federal contract, grant or any other award covered by 31 U.S.C. 1352. Each tier must also disclose any lobbying with non-Federal funds that takes place in connection with obtaining any Federal award. Such disclosures are forwarded from tier to tier up to the non-federal award.

CIVIL RIGHTS ACT OF 1964 (Title VI 42 U.S.C. § 2000d)

Title VI of the Civil Rights Act of 1964, Section 109 of the Community Development Act of 1974, Section 504 of the Rehabilitation Act of 1973 (29 U.S.C. Section 794) (24 CFR Parts 8-9), and the Americans with Disabilities Act of 1990 (42 U.S.C. 12131; 47 U.S.C. 155, 201, 218, and 225), prohibits Contractors from excluding or denying individuals benefits or participation in this project on the basis of race, color, religion, national origin, sex, or disability. The provisions require that no person in the United States shall on the ground of race, color, religion, national origin, sex, or disability be excluded from participation in, be denied the benefits of, or be subjected to discrimination under any program or activity funded in whole or in part with community development funds made available pursuant to these Acts.

For purposes of this Part "program or activity" is defined as any function conducted by an identifiable administrative unit of the recipient, or private Contractor receiving community development funds or loans from the recipient. "Funded in whole or in part with community development funds" means that community development funds in any amount in the form of grants or proceeds from HUD guaranteed loans have been transferred by the recipient or a subrecipient to an identifiable administrative unit and disbursed in a program or activity. A Contractor may not, under any program or activity to which the regulations of this Part may apply directly or through contractual or other arrangements, on the grounds of race, color, national origin, or sex:

- a. Deny any facilities, services, financial aid or other benefits provided under the program or activity;
- b. Provide any facilities, services, financial aid or other benefits, which are different, or are provided in a different form from that provided to others under the program or activity;
- c. Subject to segregated or separate treatment in any facility in, or in any matter of process related to receipt of any service or benefit under the program or activity;
- d. Restrict in any way access to, or in the enjoyment of any advantage or privilege enjoyed by others in connection with facilities, services, financial aid or other benefits under the program or activity;
- e. Treat an individual differently from others in determining whether the individual satisfies any admission, enrollment, eligibility, membership, or other requirement or condition which the individual must meet in order to be provided any facilities, services or other benefit provided under the program or activity; and

GENERAL PROVISIONS

REQUEST FOR PROPOSALS MENTAL HEALTH COURT PUBLIC DEFENDER'S OFFICE BUILDOUT GALVESTON COUNTY, TEXAS

- f. Deny an opportunity to participate in a program or activity as an employee.

CLEAN AIR ACT (2 CFR Appendix II to Part 200 (G))

Pursuant to 2 CFR Appendix II to Part 200 (G), if at any time during the contract term funding to contract exceeds \$150,000, the Contractor must comply with all provisions of the Clean Air Act (42 U.S.C. 85) and Section 308 of the Federal Water Pollution Control Act (33 U.S.C. 1251-1387), as amended. Contractors securing a contract in excess of \$150,000.00 shall not expend such funds by making use of subcontracting with facilities included on the Environmental Protection Agency List of Violating Facilities as per Section 306 of the Clean Air Act, Section 508 of The Clean Water Act, Executive Order 11738, and Environmental Protection Agency Regulations 40 CFR. For any subcontractors under this contract receiving contracts in excess of \$150,000 Contractor is required to include a provision that requires compliance with all applicable standards, orders or regulations issued pursuant to the Clean Air Act (42 U.S.C. 85) and Section 308 Federal Water Pollution Control Act as amended (33 U.S.C. 1251-1387). Violations shall be reported to the Federal awarding agency and the Regional Office of the Environmental Protection Agency (EPA).

CONTRACT WORK HOURS AND SAFETY STANDARDS ACT (2 CFR Appendix II to Part 200 (E))

Pursuant to 2 CFR 200 Appendix II (E), if at any time during the contract term funding to contract exceeds \$100,000, the Contractor must comply with the Contract Work Hours and Safety Standards Act (40 U.S.C. 3701-3708). Where applicable, all contracts awarded in excess of \$100,000 that involve the employment of mechanics or laborers must include a provision for compliance with 40 U.S.C. 3702 and 3704, as supplemented by Department of Labor regulations (29 CFR Part 5). Under 40 U.S.C. 3702 of the Act, each contractor must be required to compute the wages of every mechanic and laborer on the basis of a standard work week of 40 hours. Work in excess of the standard work week is permissible provided that the worker is compensated at a rate of not less than one and a half times the basic rate of pay for all hours worked in excess of 40 hours in the work week. The requirements of 40 U.S.C. 3704 are applicable to construction work and provide that no laborer or mechanic must be required to work in surroundings or under working conditions which are unsanitary, hazardous or dangerous. These requirements do not apply to the purchases of supplies or materials or articles ordinarily available on the open market, or contracts for transportation or transmission of intelligence

- (1) Overtime Requirements – No contractor or subcontractor contracting for any part of the contract work which may require or involve the employment of laborers or mechanics shall require or permit any such laborer or mechanic in any workweek in which he or she is employed on such work to work in excess of forty hours in such workweek unless such laborer or mechanic receives compensation at a rate not less than one and one-half times the basic rate of pay for all hours worked in excess of forty hours in such workweek.
- (2) Violation: liability for unpaid wages; liquidated damages. In the event of any violation of the clause set forth in paragraph (1) of this section the contractor and any subcontractor responsible therefore shall be liable for the unpaid wages. In addition, such contractor and subcontractor shall be liable to the United States (in the case of work done under contract for the District of Columbia or a territory, to such District or to such territory), for liquidated damages. Such liquidated damages shall be computed with respect to each individual laborer or mechanic, including watchmen and guards, employed in violation of the clause set forth in paragraph (1) of this section, in the sum of \$10 for each calendar day on which such individual was required or permitted to work in excess of the standard workweek of forty hours without payment of the overtime wages required by the clause set forth in paragraph (1) of this section.
- (3) Withholding for unpaid wages and liquidated damages. The (write in the name of the Federal agency or the loan or grant recipient) shall upon its own action or upon written request of an authorized representative of the

GENERAL PROVISIONS

REQUEST FOR PROPOSALS MENTAL HEALTH COURT PUBLIC DEFENDER'S OFFICE BUILDOUT GALVESTON COUNTY, TEXAS

Department of Labor withhold or cause to be withheld, from any moneys payable on account of work performed by the contractor or subcontractor under any such contract or any other Federal contract with the same prime contractor, or any other federally-assisted contract subject to the Contract Work Hours and Safety Standards Act, which is held by the same prime contractor, such sums as may be determined to be necessary to satisfy any liabilities of such contractor or subcontractor for unpaid wages and liquidated damages as provided in the clause set forth in paragraph (2) of this section.

- (4) **Subcontracts.** The contractor or subcontractor shall insert in any subcontracts the clauses set forth in paragraph (1) through (4) of this section and also a clause requiring the subcontractors to include these clauses in any lower tier subcontracts. The prime contractor shall be responsible for compliance by any subcontractor or lower tier subcontractor with the clauses set forth in paragraphs (1) through (4) of this section.

COPELAND "ANTI-KICKBACK" ACT (40 U.S.C. 3145)

Pursuant to 2 CFR Appendix II to Part 200 (D), Contractor must comply with the provisions of the Copeland "Anti-Kickback" Act (40 U.S.C. 3145), as supplemented by Department of Labor regulations (29 CFR Part 3, "Contractors and Subcontractors on Public Building or Public Work Financed in Whole or in Part by Loans or Grants from the United States"). The Act provides that each vendor, contractor, subcontractor, or subrecipient shall be prohibited from inducing, by any means, any person employed in the construction, completion, or repair of public work, to give up any part of the compensation to which he or she is otherwise entitled. Contractor shall include this provision in all contracts between itself and any subcontractors in connection with the services performed under this Contract. Galveston County shall report all suspected or reported violations to the Federal awarding agency.

COST PLUS CONTRACTING PROHIBITED (2 CFR 200.323(D))

Cost-plus-a-percentage-of-cost (CPPC) contracts are prohibited by 2 CFR 200.323(d). The cost plus a percentage of cost and percentage of construction cost methods of contracting must never be used, including in subcontracts and third-party contracts. A cost-plus contract is one that is structured to pay the contractor or subcontractor their actual costs incurred, plus a fixed percent for profit or overhead.

A cost-plus-a-percentage-of-cost (CPPC) contract is a contract containing some element that obligates Galveston County or Contractor to pay a contractor or subcontractor an amount (in the form of either profit or cost), undetermined at the time the contract was made, to be incurred in the future, and based on a percentage of future costs. The inclusion of an overall contract ceiling price does not make these forms of contracts acceptable. This type of contract is prohibited because there is no incentive for the contractor or subcontractor to keep its incurred costs low. Instead, there is a reverse incentive for the contractor or subcontractor to continue to incur additional costs in order to continue to drive the percentage of cost up. In other words, increased spending by the contractor will yield higher profits. This prohibition applies to all work, regardless of the circumstances, and applies to subcontracts of the contractor cases where the prime contract is a cost-reimbursement type contract or subject to price redetermination.

DAVIS BACON AND RELATED ACTS (2 CFR 200 APPENDIX II (D))

Pursuant to 2 CFR 200 Appendix II (D), for any contract in excess of \$2,000, Contractor must comply with the Davis Bacon and Related Acts, and the requirements shall be applicable to any labor or mechanic work completed in connection with this contract which fall under the Davis Bacon Act. Any Contractor awarded under this contract is required to comply with the Davis Bacon Act (40 U.S.C. 3141-3144, and 3146-3148) as supplemented by Department of Labor regulations (29 CFR part 5) and with the Copeland "Anti-Kickback" Act (18 U.S.C. 874; 40 U.S.C. 3145) as supplemented in Department of Labor regulations (29 CFR part 3). In accordance with the statute, Contractors are required to pay wages to laborers and mechanics at a rate not less than the prevailing wages specified in a wage

GENERAL PROVISIONS

REQUEST FOR PROPOSALS MENTAL HEALTH COURT PUBLIC DEFENDER'S OFFICE BUILDOUT GALVESTON COUNTY, TEXAS

determination made by the Secretary of Labor. In addition, contractors must be required to pay wages not less than once a week.

If Davis Bacon is applicable, Galveston County will provide a copy of the current Davis Bacon Wage Decision with the solicitation. The decision to award a contract or subcontract shall be conditioned upon the acceptance of the wage determination. Contractor shall submit certified payroll of contractor and all subcontractors on a weekly basis in the format required by the County. At County's request, Contractor shall make available and shall require its subcontractors to make available, copies of cancelled checks and check stubs for comparisons by the County or its agents.

Such laborers and mechanics shall be paid the appropriate wage rate and fringe benefits on the wage determination for the classification of work actually performed, without regard to skill, except as provided in 29 CFR Part 5.5(a)(4). Laborers or mechanics performing work in more than one classification may be compensated at the rate specified for each classification for the time actually worked therein: Provided that the employer's payroll records accurately set forth the time spent in each classification in which work is performed. The wage determination (including any additional classification and wage rates conformed under 29 CFR Part 5.5(a)(1)(ii)) and the Davis Bacon poster (WH-1321) shall be posted at all times by the contractor and its subcontractors at the site of the work in a prominent and accessible place where it can be easily seen by the workers.

Each payroll submitted shall be accompanied by a "Statement of Compliance," signed by the contractor or subcontractor or his or her agent who pays or supervises the payment of the persons employed under the contract and shall certify the following. The Statement of Compliance can be found on page 2 of the WH-347 form, and/or additional certifications of compliance may be required by Galveston County. Any Statement of Compliance is subject to the penalties provided by 18 U.S.C. § 1001, namely, a fine, possible imprisonment of not more than 5 years, or both. Accordingly, the party signing the statement should have knowledge of the facts represented as true. Contractor must include this provision in all contracts between itself and any subcontractors in connection with the services performed under this Contract. Galveston County shall report all suspected or reported violations to the Federal awarding agency, as applicable.

DEBARMENT / SUSPENSION AND VOLUNTARY EXCLUSION (2 CFR Appendix II to Part 200 (I))

Pursuant to 2 CFR Appendix II to Part 200 (I), a Contract meeting the definition in 2 C.F.R. § 180.220 must not be made to parties listed on the System for Award Management (SAM) Exclusion lists, in accordance with the OMB guidelines at 2 CFR 180 that implement Executive Orders 12549 (3 CFR part 1986 Comp., p. 189) and 12689 (3 CFR part 1989 Comp., p. 235), "Debarment and Suspension." SAM Exclusions contains the names of parties debarred, suspended, or otherwise excluded by agencies, as well as parties declared ineligible under statutory or regulatory authority other than Executive Order 12549.

Pursuant to Executive Orders 12549 and 12689, a contract award shall not be made to parties listed on the government-wide exclusions in the System for Award Management (SAM), in accordance with the OMB guidelines at 2 CFR 180 that implement Executive Orders 12549 (3 CFR part 1986 Comp., p. 189) and 12689 (3 CFR part 1989 Comp., p. 235). SAM Exclusions contains the names of parties debarred, suspended, or otherwise excluded by agencies, as well as parties declared ineligible under statutory or regulatory authority other than Executive Order 12549. A contract award must not be made to parties listed in the SAM Exclusions. SAM exclusions can be accessed at www.sam.gov.

Additionally, no contracts shall be awarded to any Contractor that has been debarred, suspended, or otherwise excluded from or ineligible for participation in any federal programs, including but not limited to the Department of Health and Human Work (DHHS), Office of Inspector General (OIG) - List of Excluded Individuals & Entities (LEIE); U.S. General Services Administration (GSA) - Excluded Parties List System (EPLS); All States (50) Health & Human Work Commission Medicaid OIG Sanction List; Government Terrorist Watch List (OFAC / Patriot Act); Department of Commerce, Bureau of Industry and Security, Denied Persons List; and Department of Homeland Security, Immigration and Customs Enforcement (ICE) Most Wanted.

GENERAL PROVISIONS

REQUEST FOR PROPOSALS MENTAL HEALTH COURT PUBLIC DEFENDER'S OFFICE BUILDOUT GALVESTON COUNTY, TEXAS

This contract is a covered transaction for purposes of compliance with Title 2 C.F.R. parts 180 and 3000, and as such the Contractor is required to verify that none of the contractor, its principals (as defined at 2 C.F.R. § 180.995), or its affiliates (as defined at 2 C.F.R. § 180.905) are excluded (as defined at 2 C.F.R. § 180.940) or disqualified (as defined at 2 C.F.R. § 180.935). These regulations restrict awards, subawards, and contracts with certain parties that are debarred, suspended, or otherwise excluded from or ineligible for participation in Federal assistance programs and activities (See 2 C.F.R. Part 200, Appendix II). The Contractor must comply with 2 C.F.R. part 180, subpart C and 2 C.F.R. part 3000, subpart C and shall include this requirement and similar certification in all contracts between itself and any subcontractors in connection with the services performed under this Contract.

The Contractor confirms that it is eligible or otherwise not disqualified or prohibited from participation in federal or state assistance programs under Executive Order 12549, Debarment and Suspension. Additionally, the Contractor warrants that it is not debarred, suspended, or otherwise excluded from or ineligible for participation in any federal programs, including but not limited to the following: Department of Health and Human Work (DHHS), Office of Inspector General (OIG) - List of Excluded Individuals & Entities (LEIE); U.S. General Services Administration (GSA) – Excluded Parties List System (EPLS); All States (50) Health & Human Work Commission Medicaid OIG Sanction List; Government Terrorist Watch List (OFAC / Patriot Act); Department of Commerce, Bureau of Industry and Security, Denied Persons List; and Department of Homeland Security, Immigration and Customs Enforcement (ICE) Most Wanted. Galveston County reserves the right to verify any contractor's status and document instances of debarment, suspension, or other ineligibility.

Contractor shall verify that all subcontractors performing work under this Contract are not debarred, disqualified, or otherwise prohibited from participation in accordance with the requirements above. The Contractor further must notify Galveston County in writing immediately if Contractor or its subcontractors are not in compliance with Executive Order 12549 during the term of this contract. Contractor shall include this provision in all contracts between itself and any subcontractors in connection with the services performed under this Contract.

If it is found that the Contractor did not comply or is not in compliance with Executive Order 12549 (2 C.F.R. part 180, subpart C and 2 C.F.R. part 3000, subpart C), the Contractor may be subject to available remedies, including but not limited to, refunding Galveston County for any payments made to the Contractor while ineligible, and also acknowledges that the Federal Government may pursue available remedies, including but not limited to suspension and/or debarment.

EQUAL EMPLOYMENT OPPORTUNITY (41 CFR 60-1.4(b) and 2 CFR 200 APPENDIX II (C))

Contractor must comply with, and incorporate or cause to be incorporated into any contract for construction work, or modification thereof, the Equal Employment Opportunity provisions as follows:

During the performance of this contract, the contractor agrees as follows:

1. The contractor will not discriminate against any employee or applicant for employment because of race, color, religion, sex, sexual orientation, gender identity, or national origin. The contractor will take affirmative action to ensure that applicants are employed, and that employees are treated during employment without regard to their race, color, religion, sex, sexual orientation, gender identity, or national origin. Such action shall include, but not be limited to the following:

Employment, upgrading, demotion, or transfer; recruitment or recruitment advertising; layoff or termination; rates of pay or other forms of compensation; and selection for training, including apprenticeship. The contractor agrees to post in conspicuous places, available to employees and applicants for employment, notices to be provided setting forth the provisions of this nondiscrimination clause.

GENERAL PROVISIONS

REQUEST FOR PROPOSALS MENTAL HEALTH COURT PUBLIC DEFENDER'S OFFICE BUILDOUT GALVESTON COUNTY, TEXAS

2. The contractor will, in all solicitations or advertisements for employees placed by or on behalf of the contractor, state that all qualified applicants will receive consideration for employment without regard to race, color, religion, sex, sexual orientation, gender identity, or national origin.
3. The contractor will not discharge or in any other manner discriminate against any employee or applicant for employment because such employee or applicant has inquired about, discussed, or disclosed the compensation of the employee or applicant or another employee or applicant. This provision shall not apply to instances in which an employee who has access to the compensation information of other employees or applicants as a part of such employee's essential job functions discloses the compensation of such other employees or applicants to individuals who do not otherwise have access to such information, unless such disclosure is in response to a formal complaint or charge, in furtherance of an investigation, proceeding, hearing, or action, including an investigation conducted by the employer, or is consistent with the contractor's legal duty to furnish information.
4. The contractor will send to each labor union or representative of workers with which he has a collective bargaining agreement or other contract or understanding, a notice to be provided advising the said labor union or workers' representatives of the contractor's commitments under this section and shall post copies of the notice in conspicuous places available to employees and applicants for employment.
5. The contractor will comply with all provisions of Executive Order 11246 of September 24, 1965, and of the rules, regulations, and relevant orders of the Secretary of Labor.
6. The contractor will furnish all information and reports required by Executive Order 11246 of September 24, 1965, and by rules, regulations, and orders of the Secretary of Labor, or pursuant thereto, and will permit access to his books, records, and accounts by the administering agency and the Secretary of Labor for purposes of investigation to ascertain compliance with such rules, regulations, and orders.
7. In the event of the contractor's noncompliance with the nondiscrimination clauses of this contract or with any of the said rules, regulations, or orders, this contract may be canceled, terminated, or suspended in whole or in part and the contractor may be declared ineligible for further Government contracts or federally assisted construction contracts in accordance with procedures authorized in Executive Order 11246 of September 24, 1965, and such other sanctions may be imposed and remedies invoked as provided in Executive Order 11246 of September 24, 1965, or by rule, regulation, or order of the Secretary of Labor, or as otherwise provided by law.
8. The contractor will include the portion of the sentence immediately preceding paragraph (1) and the provisions of paragraphs (1) through (8) in every subcontract or purchase order unless exempted by rules, regulations, or orders of the Secretary of Labor issued pursuant to section 204 of Executive Order 11246 of September 24, 1965, so that such provisions will be binding upon each subcontractor or vendor. The contractor will take such action with respect to any subcontract or purchase order as the administering agency may direct as a means of enforcing such provisions, including sanctions for noncompliance:

Provided, however, that in the event a contractor becomes involved in, or is threatened with, litigation with a subcontractor or vendor as a result of such direction by the administering agency, the contractor may request the United States to enter into such litigation to protect the interests of the United States.

The Contractor further agrees that it will be bound by the above equal opportunity clause with respect to its own employment practices when it participates in federally assisted construction work: Provided, That if the applicant so

GENERAL PROVISIONS

REQUEST FOR PROPOSALS MENTAL HEALTH COURT PUBLIC DEFENDER'S OFFICE BUILDOUT GALVESTON COUNTY, TEXAS

participating is a State or local government, the above equal opportunity clause is not applicable to any agency, instrumentality or subdivision of such government which does not participate in work on or under the contract.

The Contractor agrees that it will assist and cooperate actively with the administering agency and the Secretary of Labor in obtaining the compliance of contractors and subcontractors with the equal opportunity clause and the rules, regulations, and relevant orders of the Secretary of Labor, that it will furnish the administering agency and the Secretary of Labor such information as they may require for the supervision of such compliance, and that it will otherwise assist the administering agency in the discharge of the agency's primary responsibility for securing compliance.

The Contractor further agrees that it will refrain from entering into any contract or contract modification subject to Executive Order 11246 of September 24, 1965, with a contractor debarred from, or who has not demonstrated eligibility for, Government contracts and federally assisted construction contracts pursuant to the Executive Order and will carry out such sanctions and penalties for violation of the equal opportunity clause as may be imposed upon contractors and subcontractors by the administering agency or the Secretary of Labor pursuant to Part II, Subpart D of the Executive Order. In addition, the Contractor agrees that if it fails or refuses to comply with these undertakings, the administering agency may take any or all of the following actions: Cancel, terminate, or suspend in whole or in part this grant (contract, loan, insurance, guarantee); refrain from extending any further assistance to the Contractor under the program with respect to which the failure or refund occurred until satisfactory assurance of future compliance has been received from such Contractor; and refer the case to the Department of Justice for appropriate legal proceedings. Contractor must include the equal opportunity clause in each of its nonexempt subcontracts, and to require all non-exempt subcontractors to include the equal opportunity clause in each of its nonexempt subcontracts.

EQUAL EMPLOYMENT OPPORTUNITY FOR WORKERS WITH DISABILITIES (48 CFR 52.22236)

During the performance of this contract, the Contractor must comply with required Equal Employment Opportunity for Workers with Disabilities provisions.

Contractor shall include the following equal opportunity clause in each of its covered Government contracts or subcontracts (and modifications, renewals, or extensions thereof if not included in the original contract):

- a. Equal opportunity clause. The Contractor shall adhere by the requirements of the equal opportunity clause at 41 CFR 60-741.5(a), as of March 24, 2014. This clause prohibits discrimination against qualified individuals on the basis of disability and requires affirmative action by the Contractor to employ and advance in employment qualified individuals with disabilities.
- b. Subcontracts. The Contractor shall include the terms of this clause in every subcontract or purchase order in excess of \$15,000 unless exempted by rules, regulations, or orders of the Secretary, so that such provisions will be binding upon each subcontractor or vendor. The Contractor shall act as specified by the Director, Office of Federal Contract Compliance Programs of the U.S. Department of Labor, to enforce the terms, including action for noncompliance. Such necessary changes in language may be made as shall be appropriate to identify properly the parties and their undertakings.

EQUAL EMPLOYMENT OPPORTUNITY FOR VEVRAA PROTECTED VETERANS (41 CFR 60.300)

Galveston County is an equal opportunity employer of protected veterans. During the performance of this contract, the Contractor must comply with required Equal Employment Opportunity for VEVRAA Protected Veterans provisions. Contractor shall include the following equal opportunity clause in each of its covered Government contracts or subcontracts (and modifications, renewals, or extensions thereof if not included in the original contract):

- a. The definitions set forth in 41 CFR 60-300.2 apply to the terms used throughout this Clause, and they are incorporated herein by reference.

GENERAL PROVISIONS

REQUEST FOR PROPOSALS MENTAL HEALTH COURT PUBLIC DEFENDER'S OFFICE BUILDOUT GALVESTON COUNTY, TEXAS

- b. The contractor shall not discriminate against any employee or applicant for employment because he or she is a disabled veteran, recently separated veteran, active-duty wartime or campaign badge veteran, or Armed Forces service medal veteran (hereinafter collectively referred to as "protected veteran(s)") in regard to any position for which the employee or applicant for employment is qualified. The contractor agrees to take affirmative action to employ, advance in employment and otherwise treat qualified individuals without discrimination based on their status as a protected veteran in all employment practices, including the following:
- i Recruitment, advertising, and job application procedures.
 - ii Hiring, upgrading, promotion, award of tenure, demotion, transfer, layoff, termination, right of return from layoff and rehiring.
 - iii Rates of pay or any other form of compensation and changes in compensation.
 - iv Job assignments, job classifications, organizational structures, position descriptions, lines of progression, and seniority lists.
 - v Leaves of absence, sick leave, or any other leave.
 - vi Fringe benefits available by virtue of employment, whether or not administered by the contractor.
 - vii Selection and financial support for training, including apprenticeship, and on-the-job training under 38 U.S.C. 3687, professional meetings, conferences, and other related activities, and selection for leaves of absence to pursue training.
 - viii Activities sponsored by the contractor including social or recreational programs.
 - ix Any other term, condition, or privilege of employment.
- c. The contractor shall immediately list all employment openings which exist at the time of the execution of this contract and those which occur during the performance of this contract, including those not generated by this contract and including those occurring at an establishment of the contractor other than the one where the contract is being performed, but excluding those of independently operated corporate affiliates, with the appropriate employment service delivery system where the opening occurs. Listing employment openings with the state workforce agency job bank or with the local employment service delivery system where the opening occurs will satisfy the requirement to list jobs with the appropriate employment service delivery system. In order to satisfy the listing requirement described herein, contractors must provide information about the job vacancy in any manner and format permitted by the appropriate employment service delivery system which will allow that system to provide priority referral of veterans protected by VEVRAA for that job vacancy. Providing information on employment openings to a privately run job service or exchange will satisfy the contractor's listing obligation if the privately run job service or exchange provides the information to the appropriate employment service delivery system in any manner and format that the employment service delivery system permits which will allow that system to provide priority referral of protected veterans.
- d. Listing of employment openings with the appropriate employment service delivery system pursuant to this clause shall be made at least concurrently with the use of any other recruitment source or effort and shall

GENERAL PROVISIONS

REQUEST FOR PROPOSALS MENTAL HEALTH COURT PUBLIC DEFENDER'S OFFICE BUILDOUT GALVESTON COUNTY, TEXAS

involve the normal obligations which attach to the placing of a bona fide job order, including the acceptance of referrals of veterans and nonveterans. The listing of employment openings does not require the hiring of any particular job applicants or from any particular group of job applicants, and nothing herein is intended to relieve the contractor from any requirements in Executive orders or regulations regarding nondiscrimination in employment.

- e. Whenever a contractor, other than a state or local governmental contractor, becomes contractually bound to the listing provisions in paragraphs 2 and 3 of this clause, it shall advise the employment service delivery system in each state where it has establishments that: (a) It is a Federal contractor, so that the employment service delivery systems are able to identify them as such; and (b) it desires priority referrals from the state of protected veterans for job openings at all locations within the state. The contractor shall also provide to the employment service delivery system the name and location of each hiring location within the state and the contact information for the contractor official responsible for hiring at each location. The "contractor official" may be a chief hiring official, a Human Resources contact, a senior management contact, or any other manager for the contractor that can verify the information set forth in the job listing and receive priority referrals from employment service delivery systems. In the event that the contractor uses any external job search organizations to assist in its hiring, the contractor shall also provide to the employment service delivery system the contact information for the job search organization(s). The disclosures required by this paragraph shall be made simultaneously with the contractor's first job listing at each employment service delivery system location after the effective date of this final rule. Should any of the information in the disclosures change since it was last reported to the employment service delivery system location, the contractor shall provide updated information simultaneously with its next job listing. As long as the contractor is contractually bound to these provisions and has so advised the employment service delivery system, there is no need to advise the employment service delivery system of subsequent contracts. The contractor may advise the employment service delivery system when it is no longer bound by this contract clause.
- f. The provisions of paragraphs 2 and 3 of this clause do not apply to the listing of employment openings which occur and are filled outside of the 50 states, the District of Columbia, the Commonwealth of Puerto Rico, Guam, the Virgin Islands, American Samoa, the Commonwealth of the Northern Mariana Islands, Wake Island, and the Trust Territories of the Pacific Islands.
- g. As used in this clause:
- i. All employment openings include all positions except executive and senior management, those positions that will be filled from within the contractor's organization, and positions lasting three days or less. This term includes full-time employment, temporary employment of more than three days' duration, and part-time employment.
 - ii. Executive and senior management means: (1) Any employee (a) compensated on a salary basis at a rate of not less than \$455 per week (or \$380 per week, if employed in American Samoa by employers other than the Federal Government), exclusive of board, lodging or other facilities; (b) whose primary duty is management of the enterprise in which the employee is employed or of a customarily recognized department or subdivision thereof; (c) who customarily and regularly directs the work of two or more other employees; and (d) who has the authority to hire or fire other employees or whose suggestions and recommendations as to the hiring, firing, advancement, promotion or any other change of status of other employees are given particular weight; or (2) any employee who owns at

GENERAL PROVISIONS

REQUEST FOR PROPOSALS MENTAL HEALTH COURT PUBLIC DEFENDER'S OFFICE BUILDOUT GALVESTON COUNTY, TEXAS

least a bona fide 20-percent equity interest in the enterprise in which the employee is employed, regardless of whether the business is a corporate or other type of organization, and who is actively engaged in its management.

- iii. Positions that will be filled from within the contractor's organization means employment openings for which no consideration will be given to persons outside the contractor's organization (including any affiliates, subsidiaries, and parent companies) and includes any openings which the contractor proposes to fill from regularly established "recall" lists. The exception does not apply to a particular opening once an employer decides to consider applicants outside of his or her own organization.
- h. The contractor shall comply with the rules, regulations, and relevant orders of the Secretary of Labor issued pursuant to the Act.
- i. In the event of the contractor's noncompliance with the requirements of this clause, actions for noncompliance may be taken in accordance with the rules, regulations, and relevant orders of the Secretary of Labor issued pursuant to the Act.
- j. The contractor agrees to post in conspicuous places, available to employees and applicants for employment, notices in a form to be prescribed by the Director, Office of Federal Contract Compliance Programs, provided by or through the contracting officer. Such notices shall state the rights of applicants and employees as well as the contractor's obligation under the law to take affirmative action to employ and advance in employment qualified employees and applicants who are protected veterans. The contractor must ensure that applicants or employees who are disabled veterans are provided the notice in a form that is accessible and understandable to the disabled veteran (e.g., providing Braille or large print versions of the notice, posting the notice for visual accessibility to persons in wheelchairs, providing the notice electronically or on computer disc, or other versions). With respect to employees who do not work at a physical location of the contractor, a contractor will satisfy its posting obligations by posting such notices in an electronic format, provided that the contractor provides computers that can access the electronic posting to such employees, or the contractor has actual knowledge that such employees otherwise are able to access the electronically posted notices. Electronic notices for employees must be posted in a conspicuous location and format on the company's intranet or sent by electronic mail to employees. An electronic posting must be used by the contractor to notify job applicants of their rights if the contractor utilizes an electronic application process. Such electronic applicant notice must be conspicuously stored with, or as part of, the electronic application.
- k. The contractor will notify each labor organization or representative of workers with which it has a collective bargaining agreement or other contract understanding that the contractor is bound by the terms of VEVRAA and is committed to take affirmative action to employ and advance in employment, and shall not discriminate against, protected veterans.
- l. The contractor will include the provisions of this clause in every subcontract or purchase order of \$100,000 or more, unless exempted by the rules, regulations, or orders of the Secretary issued pursuant to VEVRAA so that such provisions will be binding upon each subcontractor or vendor. The contractor will take such action with respect to any subcontract or purchase order as the Director, Office of Federal Contract Compliance Programs, may direct to enforce such provisions, including action for noncompliance.

GENERAL PROVISIONS

REQUEST FOR PROPOSALS MENTAL HEALTH COURT PUBLIC DEFENDER'S OFFICE BUILDOUT GALVESTON COUNTY, TEXAS

- m. The contractor must, in all solicitations or advertisements for employees placed by or on behalf of the contractor, state that all qualified applicants will receive consideration for employment without regard to their protected veteran status.
- n. The Contractor shall forfeit as a penalty to the County who administers the subject Project receiving Federal assistance, Sixty Dollars (\$60.00) for each worker, employed for each calendar day, or a portion thereof, such worker is paid less than the said stipulated rates for any work done under this Project, by him/her or by any contractor under him/her.
- o. All contractors shall keep, or cause to be kept, an accurate record showing the names of all workers, also the actual per diem wages paid to each of such workers.

FAIR LABOR STANDARDS ACT

Contractor must comply the Fair Labor Standards Act of 1938 (29 U.S.C. Section 201 et seq.) as now or hereafter amended, which regulates wage, hour and other employment practices that govern the use of funds provided and the employment of personnel under this contract. The Contractor warrants that it will pay all its workers all monies earned by its workers including, but not limited to regular wages, any overtime compensation, or any additional payments pursuant to the Fair Labor Standards Act, 29 United States Code (U.S.C.) Section 207 9a(1), as amended; the Texas Pay Day Act; the Equal Pay Act; Title VII of the Civil Rights Act of 1964, 42 U.S.C. Section 2000, et al., as amended; or any provisions of the Texas Labor Code Ann., as amended.

FLOOD DISASTER PROTECTION ACT OF 1973 (24 CFR 570.605)

Contractor must comply with the provisions in 24 CFR 570.605, Section 202(a) of the Flood Disaster Protection Act of 1973 (42 U.S.C. 4106), and the regulations in 44 CFR Parts 59-79.

GREEN BUILDING STANDARDS

At a minimum, Contractors and subcontractors must comply with local codes and any applicable national building codes for any work involving rehabilitation or construction, including design. When a contract is funded, in whole or in part, by HUD funding, Contractors must comply with applicable Green Building standards to the maximum extent feasible. Green Building standards may apply to single-family properties, multifamily properties, or both and may include, but are not limited to best practices defined under LEED, Enterprise Green Communities, or NAHB National Green Building Standards and may include specific measures for water conservation, energy efficiency, and indoor air quality. Contractor and subcontractors must comply with the following standards, as applicable:

- 2009 ICC International Energy Conservation Code (IECC)
- ASHRAE 90.1-2007, which sets minimum energy standards for buildings except low-rise residential buildings
- ASHRAE 62.1-2010 and 62.2-2010, which set minimum standards for ventilation for indoor air quality for common areas in mid- and high-rise buildings, and low-rise residential buildings, respectively.
- New or replacement residential housing, when funded by CDBG-DR grants, must adhere to Green Building standards, including Energy Star Certified Homes or Energy Star for Multifamily High Rise and other applicable green building requirements.
- Moderate residential housing rehabilitation, when funded by CDBG-DR grants, must comply with the Community Planning & Development (CPD) Retrofit Checklist and provide Energy Star appliances, Water Sense or FEMP products if replaced.

GENERAL PROVISIONS

REQUEST FOR PROPOSALS MENTAL HEALTH COURT PUBLIC DEFENDER'S OFFICE BUILDOUT GALVESTON COUNTY, TEXAS

- New or replacement residential housing, when funded by CDBG-DR grants, must adhere to Green Building standards, including Energy Star Certified Homes or Energy Star for Multifamily High Rise and other applicable green building requirements.

HOLD HARMLESS AGREEMENT

Contractor shall indemnify, defend, and hold harmless Galveston County from all claims for personal injury, death and/or property damage resulting directly or indirectly from contractor's performance. Contractor shall procure and maintain, with respect to the subject matter of this Invitation for RFPs, appropriate insurance coverage including, at a minimum, public liability and property damage with adequate limits to cover contractor's liability as may arise directly or indirectly from work performed under terms of this Invitation for RFPs. Certification of such coverage must be provided to the County upon request.

The Federal Government is not a party to this contract and is not subject to any obligations or liabilities to the non-Federal entity, contractor, or any other party pertaining to any matter resulting from the contract.

LEAD-BASED PAINT (24 CFR 570.608)

Contractor and subcontractors must comply with the provisions found in 24 CFR 570.608, the Lead-Based Paint Poisoning Prevention Act (42 U.S.C. 4821-4846), the Residential Lead Based Paint Hazard Reduction Act of 1992 (U.S.C. 4851-4856, and 24 CFR Part 35, subparts A, B, J, K, and R. This Article 2(f) is to be included in all subcontracts, for work in connection with this Contract, which relate to residential structures.

NON-COLLUSION (The Sherman Act)

Contractor must comply with the requirements of The Sherman Act, which prohibit collusion. Collusion occurs when two persons or representatives of an entity or organization make an agreement to deceive or mislead another. Such agreements are usually secretive and involve fraud or gaining an unfair advantage over a third party, competitors, consumers or others with whom they are negotiating. The collusion, therefore, makes the bargaining process inherently unfair. Collusion can involve promises of future benefits, price or wage fixing, kickbacks, or misrepresenting the independence of the relationship between the colluding parties.

The Sherman Act prohibits any agreement among competitors to fix prices, rig RFPs, or engage in other anticompetitive activity. Collusion, RFP rigging, or other anticompetitive activity is considered a felony.

Contractor shall not in any way, directly or indirectly:

- a. Collude, conspire, or agree with any other person, firm, corporation, Responder or potential Responder to the amount of this RFP or the terms or conditions of this RFP.
- b. Pay or agree to pay any other person, firm, corporation Responder or potential Responder any money or anything of value in return for assistance in procuring or attempting to procure a contract or in return for establishing the prices in the attached RFP or the RFP of any other Responder.
- c. Assemble in coordination with any other organization in an attempt to fix the price of the work.

Contractors are expected to report any suspected fraud, collusion, or impropriety from the inception of solicitation through the end of the contract term.

GENERAL PROVISIONS

REQUEST FOR PROPOSALS MENTAL HEALTH COURT PUBLIC DEFENDER'S OFFICE BUILDOUT GALVESTON COUNTY, TEXAS

NON-SEGREGATED FACILITIES

"Prohibition of Segregated Facilities"

- a. Segregated facilities means any waiting rooms, work areas, rest rooms and wash rooms, restaurants and other eating areas, time clocks, locker rooms and other storage or dressing areas, parking lots, drinking fountains, recreation or entertainment areas, transportation, and housing facilities provided for employees, that are segregated by explicit directive or are in fact segregated on the basis of race, color, religion, sex, sexual orientation, gender identity, or national origin because of written or oral policies or employee custom. The term does not include separate or single-user rest rooms or necessary dressing or sleeping areas provided to assure privacy between the sexes.

Sexual orientation has the meaning given by the Department of Labor's Office of Federal Contract Compliance Programs and is found at www.dol.gov/ofccp/LGBT/LGBT_FAQs.html.

- b. The Contractor agrees that it does not and will not maintain or provide for its employees any segregated facilities at any of its establishments, and that it does not and will not permit its employees to perform their services at any location under its control where segregated facilities are maintained. The Contractor agrees that a breach of this clause is a violation of the Equal Opportunity clause in this contract.
- c. The Contractor shall include this clause in every subcontract and purchase order that is subject to the Equal Opportunity clause of this contract.

PARTICIPATION BY MINORITY & WOMEN-OWNED BUSINESS ENTERPRISES (2 CFR 200.321)

Contractor must comply with the Minority and Women-owned Business Enterprise participation requirements under 2 CFR 200.321. Contractors must take all affirmative steps necessary to subcontract with Minority and Women-owned Business Enterprises (MWBEs) to assure that MWBEs are used when possible. These affirmative steps shall include:

- A. Placing qualified small and minority businesses and women's business enterprises on solicitation lists;
- B. Assuring that small and minority businesses, and women's business enterprises are solicited whenever they are potential sources;
- C. Dividing total requirements, when economically feasible, into smaller tasks or quantities to permit maximum participation by small and minority businesses, and women's business enterprises;
- D. Establishing delivery schedules, where the requirement permits, which encourage participation by small and minority businesses, and women's business enterprises; and
- E. Using the services and assistance, as appropriate, of such organizations as the Small Business Administration and the Minority Business Development Agency of the Department of Commerce.

The State of Texas maintains a Historically Underutilized Business Program, which identifies any business at least 51 percent owned by an Asian Pacific American, Black American, Hispanic American, Native American, American woman and/or Service-Disabled Veteran, who resides in Texas and actively participate in the control, operations and management of the entity's affairs as a Historically Underutilized Business (also considered MWBE). Contractors who wish to check the status of a firm may visit <https://comptroller.texas.gov/purchasing/vendor/hub/>.

Contractors and subcontractors are required to facilitate Minority & Women-Owned Business Enterprise participation. Contractors are encouraged to utilize MWBEs / HUB firms as subcontractors, subconsultants, or suppliers in order to

GENERAL PROVISIONS

REQUEST FOR PROPOSALS MENTAL HEALTH COURT PUBLIC DEFENDER'S OFFICE BUILDOUT GALVESTON COUNTY, TEXAS

comply with the requirements and may check for firms who perform relevant work by searching <https://comptroller.texas.gov/purchasing/vendor/hub/>.

Contractor and subcontractors must facilitate Minority & Women-Owned Business Enterprise participation and take all affirmative steps to utilize MWBEs / HUB firms as subcontractors, subconsultants, or suppliers throughout the life of the Contract.

POTENTIAL CONFLICTS OF INTEREST

Pursuant to 2 CFR 200.112, Contractor must comply with disclosure requirements in accordance with Texas Local Government Code, Chapter 176. Contractor shall not use funds to directly or indirectly pay any person for influencing or attempting to influence any public employee or official in connection with the awarding of any contract or the extension, continuation, renewal, amendment or modification of any contract. By law, the Conflict of Interest Questionnaire (provided by the Texas Ethics Commission at www.ethics.state.tx.us) must be filed with the records administrator of the local governmental entity not later than the 7th business day after the date the Contractor becomes aware of facts that require the statement to be filed.

This law requires persons desiring to do business with the County to disclose any gifts valued in excess of \$250 given to any County Official or the County Official's family member, or employment of any County Official or the County Official's family member during the preceding twelve (12) month period. The disclosure questionnaire must be filed with the Galveston County Clerk. Refer to Texas Local Government Code, Chapter 176 for the details of this law.

An outside consultant or contractor is prohibited from submitting a RFP for services on a Galveston County project of which the consultant or contractor was a designer or other previous contributor, or was an affiliate, subsidiary, joint venture or was in any other manner associated by ownership to any party that was a designer or other previous contributor. If such a consultant or contractor submits a prohibited RFP, that RFP shall be disqualified on the basis of conflict of interest, no matter when the conflict is discovered by Galveston County.

PREVAILING WAGES (2 CFR 200 APPENDIX II (D) and TGC 2258)

Pursuant to 2 CFR 200 Appendix II (D), Contractor must comply with Texas Government Code (TGC) 2258, Prevailing Wage Rates. Accordingly, Contractor must submit a certified payroll records as required, and compensate any worker employed on a public works project not less than as applicable. As noted under "Davis Bacon and Related Acts", when required by Federal program legislation, construction contracts in excess of \$2,000 awarded by Galveston County shall require compliance with the Davis-Bacon Act (40 U.S.C. 3141-3144, and 3146-3148) as supplemented by Department of Labor regulations (29 CFR Part 5, "Labor Standards Provisions Applicable to Contracts Covering Federally Financed and Assisted Construction"). In accordance with the statute, Contractor must pay wages to laborers and mechanics at a rate not less than the local prevailing wages, or Davis Bacon wages, as applicable. If both Texas prevailing wages and Davis Bacon provide rates for a particular class, Contractors must pay the greater wage rate. In addition, Contractor must pay wages not less than once a week.

In compliance with Section 2258 of the Texas Government Code, Contractor and any subcontractor hired by Contractor for the construction of any project, shall pay not less than the rates set forth in the Schedule of Prevailing Wages attached and incorporated by reference. In submitting a RFP, Contractor warrants that it and its subcontractors shall comply with all requirements and worker ratios per the applicable Schedule of Prevailing Wages and Texas state law.

Contractor must submit certified payroll of contractor and all subcontractors on a weekly basis. At County's request, Contractor must make available and shall require its subcontractors to make available, copies of cancelled checks and check stubs for comparisons by the County or its agents. Regardless of whether Davis Bacon or Texas Prevailing Wages apply, the County reserves the right for its agents to visit the project site and to interview contractor, its subcontractors and employees of each on any date or time, as often as desired during the construction period, without prior notification.

GENERAL PROVISIONS

REQUEST FOR PROPOSALS MENTAL HEALTH COURT PUBLIC DEFENDER'S OFFICE BUILDOUT GALVESTON COUNTY, TEXAS

Galveston County will ascertain if proper wage rates are being paid to the employees as required. In the event of a discrepancy between the work performed and the wages paid, the County shall document same and notify Contractor. If, for any length of time and as determined by Galveston County, discrepancies appear between the certified payrolls and the actual wage paid, the County shall require check stubs to be attached to each weekly certified payroll. Pursuant to Texas Government Code Section 2258.051, the County reserves the right to withhold any monies due Contractor until such discrepancy is resolved and the necessary adjustment made. The Contractor shall forfeit as a penalty, in accordance with Texas Government Code Section 2258.023(b), to the County or entity who administers the subject Project receiving Federal assistance, Sixty Dollars (\$60.00) for each worker, employed for each calendar day, or a portion thereof, such worker is paid less than the said stipulated rates for any work done under this Project, by him/her or by any contractor/subcontractor under him/her.

All contractor/subcontractor shall keep, or cause to be kept, an accurate record showing the names of all workers, also the actual per diem wages paid to each of such workers. Contractor shall impose these same obligations upon its Subcontractors. Contractor understands that with weekly or monthly certified payrolls, contractor is responsible for any and all penalties that shall accrue during the month, regardless of the fact that any error could not be discovered by the Contract Compliance Officer until the following certified payroll.

PROCUREMENT OF RECOVERED MATERIALS (2 CFR 200.322)

Pursuant to 2 CFR 200.322, Contractor must comply with Section 6002 of the Solid Waste Disposal Act, Pub. L. No. 89-272 (1965) (codified as amended by the Resource Conservation and Recovery Act at 42 U.S.C. § 6962). As such, any contractors awarded under this contract opportunity is subject to the requirements of Section 6002, which include procuring only items designated in guidelines of the EPA at 40 C.F.R. Part 247 that contain the highest percentage of recovered materials practicable, consistent with maintaining a satisfactory level of competition, where the purchase price of the item exceeds \$10,000 or the value of the quantity acquired by the preceding fiscal year exceeded \$10,000; procuring solid waste management services in a manner that maximizes energy and resource recovery; and establishing an affirmative procurement program for procurement of recovered materials identified in the EPA guidelines.

PROGRAM FRAUD AND FALSE OR FRAUDULENT STATEMENTS OR RELATED ACTS

Contractor must comply with 31 U.S.C. Chapter 38, Administrative Remedies for False Claims and Statements, which shall apply to the activities and actions of the Contractor and its subcontractors pertaining to any matter resulting from the contract.

RESTRICTIONS ON PUBLIC BUILDINGS AND PUBLIC WORKS PROJECTS CERTIFICATION

- b. Definitions. The definitions pertaining to this provision are those that are set forth on the clause entitled "Restrictions on Public Works Projects." (Set out under "Contract Clauses" below.)
- c. Certification. Except as provided in paragraph (C) of this provision, by submission of its RFP or proposal, Responder certifies that it:
 - i. Is not a Contractor of a foreign country included on the list of countries that discriminate against U.S. firms published by the Office of the United States Trade Representative (USTR) (see paragraph (H) of this provision);
 - ii. Has not or will not enter into any subcontract with a subcontractor of a foreign country included on the list of countries that discriminate against U.S. firms published by the USTR, and

GENERAL PROVISIONS

REQUEST FOR PROPOSALS MENTAL HEALTH COURT PUBLIC DEFENDER'S OFFICE BUILDOUT GALVESTON COUNTY, TEXAS

- iii. Will not provide any product of a country included on the list of foreign countries that discriminate against the U.S. firms published by the USTR.
- d. Inability to certify. A Responder unable to certify in accordance with paragraph (b) of this provision shall submit with its offer a written explanation fully describing the reasons for its inability to make the certification.
- e. Applicability of 18 U.S.C. 1001. This certification is paragraph (B) of this provision concerns a matter within the jurisdiction of an agency of the United States, and the making of a false, fictitious, or fraudulent certification may render the maker subject to prosecution under Title 18 U.S.C. 1001.
- f. Notice. Responder shall provide written notice to the Contracting Officer if, at any time before the contract award, Responder learns that its certification was erroneous when submitted or has become erroneous by reason of changed circumstances.
- g. Restrictions on contract award. Unless a waiver to these restrictions is granted by the Secretary of Housing and Urban Development, no contract will be awarded to a Responder (1) who is owned or controlled by a citizen or national of a foreign country included on the list of foreign countries that discriminate against U.S. firms published by the USTR, (2) whose subcontractors are owned or controlled by citizens or national of a foreign country on the USTR list or, (3) who incorporates any product of a foreign country on the USTR list in the public works project.
- h. USTR List. The USTR published an initial list in the Federal Register on December 30, 1987 (53 FR 49244), which identified one country-Japan. The USTR can add countries to the list, and remove countries from it, in accordance with section 109 (C) of PUB. L. 100-202.

RESTRICTIONS ON PUBLIC BUILDINGS AND PUBLIC WORKS PROJECTS

- a. Definitions. "Component", as used in this clause, means those articles, materials, and supplies incorporated directly into the product. "Contractor or subcontractor of a foreign country," as used in this clause, means any Contractor or subcontractor that is a citizen or national of a foreign country or is controlled directly or indirectly by citizens or nationals of a foreign country. A contractor or subcontractor shall be considered to be a citizen or national of a foreign country, or controlled directly or indirectly by citizens or nationals of a foreign country:
 - i. If 50 percent or more of the Contractor or subcontractor is owned by a citizen or a national of the foreign country;
 - ii. If the title to 50 percent or more of the stock of the Contractor or subcontractor is held subject to trust or fiduciary obligation in favor of citizens or nationals of the foreign country.
 - iii. If 50 percent or more of the voting power in the Contractor or subcontractor is vested in or exercisable on behalf of a citizen or national of the foreign country; iv. In the case of a partnership, if any general partner is a citizen of the foreign country;
 - v. In the case of a corporation. If its presidents or other chief executive officer or the chairman of its board of directors is a citizen of the foreign country or the majority of any number of

GENERAL PROVISIONS

REQUEST FOR PROPOSALS MENTAL HEALTH COURT PUBLIC DEFENDER'S OFFICE BUILDOUT GALVESTON COUNTY, TEXAS

its directors necessary to constitute a quorum are citizens of the foreign country or the corporation is organized under the laws of the foreign country or any subdivision, territory, or possession thereof;
or

- vi. In case of a contractor or subcontractor who is a joint venture, if any participant firm is a citizen or national of a foreign country or meets any of the criteria in subparagraphs (A) 1 through 5 of this clause. "Product", as used in this clause, means construction materials, i.e. articles, materials and supplies brought to the construction site for incorporation into the public works project, including permanently affixed equipment, instruments, utilities, electronic or other devices, but not including vehicles or construction equipment. In determining the origin of a product, Galveston County will consider a product as produce in a foreign country if it has been assembled or manufactured in the foreign country, or if the cost of the components mined, produced, or manufactured in the foreign country exceed 50 percent of the cost of all its components.
- b. Restrictions. The Contractor shall not (1) knowingly enter into any subcontract under this contract with a subcontractor of a foreign country included on the list of countries that discriminate against U.S. firms published by the United States Trade Representative (see paragraph (C) of this clause, or (2) supply any product under this contract of a country included on the list of foreign countries that discriminate against U.S. firms published by the USTR.
- c. USTR List. The USTR published an initial list in the Federal Register on December 30, 1987 (53 FR 49244), which identified one country-Japan. The USTR can add other countries to the list, or remove countries from it, in accordance with section 109 (C) of PUB. L. 100-102.
- d. Certification. The Contractor may rely upon the certification of a prospective subcontractor that it is not a subcontractor of a foreign country included on the list of countries that discriminate against U.S. firms published by the USTR and that products supplied by such subcontractor for use on the Federal public works project under this contract are not products of a foreign country included on the list of foreign countries that discriminate against U.S. firms published by the USTR, unless such Contractor has knowledge that the certification is erroneous.
- e. Subcontractors. The Contractor shall incorporate this clause, modified only for the purpose of properly identifying the parties, in all subcontracts. This paragraph (E) shall also be incorporated in all subcontracts.

RIGHTS TO INVENTIONS (2 CFR Appendix II to Part 200 (F))

Any discovery or invention that arises during the course of the contract shall be reported to Galveston County. This clause requires the Contractor to disclose promptly inventions to the County (within 2 months) after the inventor discloses it in writing to Contractor personnel responsible for patent matters. The awarding agency shall determine how rights in the invention/discovery shall be allocated consistent with "Government Patent Policy" and Title 37 C.F.R. § 401.

If the Federal award meets the definition of "funding agreement" under 37 C.F.R. §.401.2(a) and the recipient or subrecipient wishes to enter into a contract with a small business firm or nonprofit organization regarding the substitution of parties, assignment or performance of experimental, developmental, or research work under that "funding agreement," the recipient or subrecipient must comply with the requirements of Title 37 C.F.R. § 401, "Rights to

GENERAL PROVISIONS

REQUEST FOR PROPOSALS MENTAL HEALTH COURT PUBLIC DEFENDER'S OFFICE BUILDOUT GALVESTON COUNTY, TEXAS

Inventions Made by Nonprofit Organizations and Small Business Firms Under Government Grants, Contracts and Cooperative Agreements,” and any implementing regulations issued by the awarding agency.

SECTION 109 OF THE HOUSING AND COMMUNITY DEVELOPMENT ACT OF 1974 (24 CFR 570.602)

Section 109 of the Act requires that no person in the United States shall on the grounds of race, color, national origin, religion, or sex be excluded from participation in, be denied the benefits of, or be subjected to discrimination under any program or activity receiving Federal financial assistance made available pursuant to the Act. Section 109 also directs that the prohibitions against discrimination on the basis of age under the Age Discrimination Act and the prohibitions against discrimination on the basis of disability under Section 504 shall apply to programs or activities receiving Federal financial assistance under Title I programs. The policies and procedures necessary to ensure enforcement of section 109 are codified in 24 CFR part 6.

TERMINATION FOR CAUSE & CONVENIENCE (2 CFR Appendix II to Part 200 (A) and (B))

Pursuant to 2 CFR Appendix II to Part 200 (A), Contracts for more than the simplified acquisition threshold currently set at \$150,000, which is the inflation adjusted amount determined by the Civilian Agency Acquisition Council and the Defense Acquisition Regulations Council (Councils) as authorized by 41 U.S.C. 1908, shall address administrative, contractual, or legal remedies in instances where contractors violate or breach contract terms, and provide for such sanctions and penalties as appropriate.

Pursuant to 2 CFR Appendix II to Part 200 (B), all contracts in excess of \$10,000 shall address termination for cause and for convenience by the non-Federal entity including the manner by which it will be affected and the basis for settlement. Galveston County shall have the right to terminate this contract for cause and convenience.

In the event of a failure by Contractor to satisfactorily perform the services specified herein and/or a default by Contractor in aRFPing by the other terms and conditions of this Contract, Galveston County may terminate the Contract on written notice to Contractor and Contractor shall be liable for all damages, costs, and expenses (including attorney fees) incurred by County related to this default. Such termination is in addition to and not in lieu of any other remedies that Galveston County may have in law or equity. Administrative remedies for nonperformance, violation or breach of contract terms, or termination of contract for default may include suspension and debarment. Galveston County may assess liquidated damages for failure to meet completion deadlines, contract breaches, or performance failures of the Contractor or its Subcontractors.

Contractor shall be provided the opportunity to cure certain performance failures or instances of default as described in the contract documents. The legal dispute resolution process as applicable under the Texas Civil Practice and Remedies Code shall include, but is not limited to, Texas and Civil Practice and Remedies Section 38 – Attorney’s Fees, Texas Civil Practice and Remedies Section 41 – Damages, and Texas Civil Practice and Remedies Section 154 – General Provisions. Galveston County and Contractor(s) should attempt to resolve any claim for breach of contract made by Contractor, to the extent it is applicable to the Contract and not preempted by other law. Except as otherwise provided by law, nothing herein is a waiver by the County or the State of Texas of the right to seek redress in a court of law.

Termination provisions are included in the Contract Requirements & Payment, Section VIII, portion of this IFB.

WHISTLEBLOWER PROTECTION ACT

Contractor, subcontractors, and employees working on this Project shall be subject 41 U.S. Code § 4712, which requires that an employee of a contractor, subcontractor, grantee, or subgrantee or personal services contractor may not be discharged, demoted, or otherwise discriminated against as a reprisal for disclosing information that the employee reasonably believes is evidence of gross mismanagement of a Federal contract or grant, a gross waste of Federal funds, an abuse of authority relating to a Federal contract or grant, a substantial and specific danger to public health or safety,

GENERAL PROVISIONS

REQUEST FOR PROPOSALS MENTAL HEALTH COURT PUBLIC DEFENDER'S OFFICE BUILDOUT GALVESTON COUNTY, TEXAS

or a violation of law, rule, or regulation related to a Federal contract (including the competition for or negotiation of a contract) or grant.

The Contractor shall inform its employees and subcontractors in writing, in the predominant language of the workforce, of employee whistleblower rights and protections under 41 U.S.C. 4712, as described in section 3.908 of the Federal Acquisition Regulation. The Contractor shall insert the substance of this clause, including this paragraph, in all subcontracts providing services for this Project.

71. NON-EXCLUSIVE LIST OF APPLICABLE LAWS, RULES, AND REGULATIONS – TEXAS GENERAL LAND OFFICE (GLO)

If applicable to the Project, Provider must be in compliance with the following laws, rules, and regulations; and any other state, federal, or local laws, rules, and regulations as may become applicable throughout the term of the Contract, and Provider acknowledges that this list may not include all such applicable laws, rules, and regulations.

Provider and is deemed to have read and understands the requirements of each of the following, if applicable to the Project under this Contract:

GENERALLY

The Acts and Regulations specified in this Contract;

Continuing Appropriations Act, 2018 and Supplemental Appropriations for Disaster Relief Requirements Act, 2017 (Public Law 115-56);

The Housing and Community Development Act of 1974 (12 U.S.C. § 5301 et seq.);

The United States Housing Act of 1937, as amended, 42 U.S.C. § 1437f(o)(13) (2016) and related provisions governing Public Housing Authority project-based assistance, and implementing regulations at 24 C.F.R. Part 983 (2016);

Cash Management Improvement Act regulations (31 C.F.R. Part 205);

Community Development Block Grants (24 C.F.R. Part 570);

Uniform Administrative Requirements, Cost Principles, and Audit Requirements for Federal Awards (2 C.F.R. Part 200);

Disaster Recovery Implementation Manual; and State of Texas Plan for Disaster Recovery: Hurricane Harvey – Round 1, dated April 6, 2018, as amended.

CIVIL RIGHTS

Title VI of the Civil Rights Act of 1964, (42 U.S.C. § 2000d et seq.); 24 C.F.R. Part 1, "Nondiscrimination in Federally Assisted Programs of the Department of Housing and Urban Development - Effectuation of Title VI of the Civil Rights Act of 1964";

Title VII of the Civil Rights Act of 1964, as amended by the Equal Employment Opportunity Act of 1972 (42 U.S.C. § 2000e, et seq.);

Title VIII of the Civil Rights Act of 1968, "The Fair Housing Act of 1968" (42 U.S.C. §3601, et seq.), as amended;

Executive Order 11063, as amended by Executive Order 12259, and 24 C.F.R. Part 107, "Nondiscrimination and Equal Opportunity in Housing under Executive Order 11063"; The failure or refusal of Provider to comply with the

GENERAL PROVISIONS

REQUEST FOR PROPOSALS MENTAL HEALTH COURT PUBLIC DEFENDER'S OFFICE BUILDOUT GALVESTON COUNTY, TEXAS

requirements of Executive Order 11063 or 24 C.F.R. Part 107 shall be a proper basis for the imposition of sanctions specified in 24 C.F.R. 107.60;

The Age Discrimination Act of 1975 (42 U.S.C. § 6101, et seq.); and

Section 504 of the Rehabilitation Act of 1973 (29 U.S.C. § 794.) and "Nondiscrimination Based on Handicap in Federally-Assisted Programs and Activities of the Department of Housing and Urban Development", 24 C.F.R. Part 8. By signing this Contract, Provider understands and agrees that the activities funded shall be performed in accordance with 24 C.F.R. Part 8; and the Architectural Barriers Act of 1968 (42 U.S.C. § 4151, et seq.), including the use of a telecommunications device for deaf persons (TDDs) or equally effective communication system.

LABOR STANDARDS

The Davis-Bacon Act, as amended (originally, 40 U.S.C. §§ 276a-276a-5 and re-codified at 40 U.S.C. §§ 3141-3148); 29 C.F.R. Part 5;

The Copeland "Anti-Kickback" Act (originally, 18 U.S.C. § 874 and re-codified at 40 U.S.C. § 3145); 29 C.F.R. Part 3;

Sections 103 and 107 of the Contract Work Hours and Safety Standards Act (originally, 40 U.S.C. §§ 327A and 330 and re-codified at 40 U.S.C. §§ 3701-3708);

Labor Standards Provisions Applicable to Contracts Covering Federally Financed and Assisted Construction (Also Labor Standards Provisions Applicable to Non-construction Contracts Subject to the Contract Work Hours and Safety Standards Act) (29 C.F.R. Part 5); and

Federal Executive Order 11246, as amended.

EMPLOYMENT OPPORTUNITIES

Section 3 of the Housing and Urban Development Act of 1968 (12 U.S.C. § 1701u); 24 C.F.R. §§ 135.3(a)(2) and (a)(3);

The Vietnam Era Veterans' Readjustment Assistance Act of 1974 (38 U.S.C. § 4212);

Title IX of the Education Amendments of 1972 (20 U.S.C. §§ 1681-1688); and

Federal Executive Order 11246, as amended.

GRANT AND AUDIT STANDARDS

Single Audit Act Amendments of 1996, 31 U.S.C. § 7501;

Uniform Administrative Requirements, Cost Principles, and Audit Requirements for Federal Awards (2 C.F.R. Part 200);

Uniform Grant and Contract Management Act (Texas Government Code Chapter 783) and the Uniform Grant Management Standards, issued by Governor's Office of Budget and Planning; and

Title 1 Texas Administrative Code § 5.167(c).

LEAD-BASED PAINT

Section 302 of the Lead-Based Paint Poisoning Prevention Act (42 U.S.C. § 4831(b)).

GENERAL PROVISIONS

REQUEST FOR PROPOSALS MENTAL HEALTH COURT PUBLIC DEFENDER'S OFFICE BUILDOUT GALVESTON COUNTY, TEXAS

HISTORIC PROPERTIES

The National Historic Preservation Act of 1966 as amended (16 U.S.C. § 470, et seq.), particularly sections 106 and 110 (16 U.S.C. §§ 470 and 470h-2), except as provided in §58.17 for Section 17 projects;

Executive Order 11593, Protection and Enhancement of the Cultural Environment, May 13, 1971 (36 FR 8921), 3 C.F.R., 1971-1975 Comp., p. 559, particularly section 2(c);

Federal historic preservation regulations as follows: 36 C.F.R. Part 800 with respect to HUD programs; and The Reservoir Salvage Act of 1960, as amended by the Archeological and Historic Preservation Act of 1974 (16 U.S.C. § 469, et seq.), particularly section 3 (16 U.S.C. §469a-1).

ENVIRONMENTAL LAW AND AUTHORITIES

Environmental Review Procedures for Recipients assuming HUD Environmental Responsibilities (24 C.F.R. Part 58, as amended);

National Environmental Policy Act of 1969, as amended (42 U.S.C. §§ 4321-4347); and Council for Environmental Quality Regulations for Implementing NEPA (40 C.F.R. Parts 1500-1508).

FLOODPLAIN MANAGEMENT AND WETLAND PROTECTION

Executive Order 11988, Floodplain Management, May 24, 1977 (42 FR 26951), 3 C.F.R., 1977 Comp., p. 117, as interpreted in HUD regulations at 24 C.F.R. Part 55, particularly Section 2(a) of the Order (For an explanation of the relationship between the decision-making process in 24 C.F.R. Part 55 and this part, see § 55.10.); and

Executive Order 11990, Protection of Wetlands, May 24, 1977 (42 FR 26961), 3 C.F.R., 1977 Comp., p. 121 particularly Sections 2 and 5.

COASTAL ZONE MANAGEMENT

The Coastal Zone Management Act of 1972 (16 U.S.C. § 1451, et seq.), as amended, particularly sections 307(c) and (d) (16 U.S.C. § 1456(c) and (d)).

SOLE SOURCE AQUIFERS

The Safe Drinking Water Act of 1974 (42 U.S.C. §§ 201, 300(f), et seq., and 21 U.S.C. §349) as amended; particularly section 1424(e)(42 U.S.C. § 300h-3(e)); and

Sole Source Aquifers (Environmental Protection Agency-40 C.F.R. part 149.).

ENDANGERED SPECIES

The Endangered Species Act of 1973 (16 U.S.C. § 1531, et seq.) as amended, particularly section 7 (16 U.S.C. § 1536).

WILD AND SCENIC RIVERS

The Wild and Scenic Rivers Act of 1968 (16 U.S.C. § 1271, et seq.) as amended, particularly sections 7(b) and (c) (16 U.S.C. § 1278(b) and (c)).

AIR QUALITY

The Clean Air Act (42 U.S.C. § 7401, et seq.) as amended, particularly sections 176(c) and (d) (42 U.S.C. §7506(c) and (d)).

Determining Conformity of Federal Actions to State or Federal Implementation Plans (Environmental Protection Agency-40 C.F.R. Parts 6, 51, and 93).

FARMLAND PROTECTION

GENERAL PROVISIONS

REQUEST FOR PROPOSALS MENTAL HEALTH COURT PUBLIC DEFENDER'S OFFICE BUILDOUT GALVESTON COUNTY, TEXAS

Farmland Protection Policy Act of 1981 (7 U.S.C. § 4201, et seq.) particularly sections 1540(b) and 1541 (7 U.S.C. §§ 4201(b) and 4202); and

Farmland Protection Policy (Department of Agriculture-7 C.F.R. part 658).

HUD ENVIRONMENTAL STANDARDS

Applicable criteria and standards specified in HUD environmental regulations (24 C.F.R. Part 51)(other than the runway clear zone and clear zone notification requirement in 24 C.F.R. § 51.303(a)(3); and

HUD Notice 79-33, Policy Guidance to Address the Problems Posed by Toxic Chemicals and Radioactive Materials, September 10, 1979.

ENVIRONMENTAL JUSTICE

Executive Order 12898 of February 11, 1994—Federal Actions to Address Environmental Justice in Minority Populations and Low-Income Populations, (59 FR 7629), 3 C.F.R., 1994 Comp. p. 859.

SUSPENSION AND DEBARMENT

Use of debarred, suspended, or ineligible contractors or subrecipients (24 C.F.R. §570.609);

General HUD Program Requirements; Waivers (24 C.F.R. Part 5); and

Nonprocurement Suspension and Debarment (2 C.F.R. Part 2424).

OTHER REQUIREMENTS

Environmental Review Procedures for Entities Assuming HUD Environmental Responsibilities (24 C.F.R. Part 58).

ACQUISITION / RELOCATION

The Uniform Relocation Assistance and Real Property Acquisition Policies Act of 1970 (42 U.S.C. § 4601, et seq.), 24 C.F.R. Part 42, and 24 C.F.R. § 570.606.

FAITH-BASED ACTIVITIES

Executive Order 13279 of December 12, 2002 - Equal Protection of the Laws for Faith-Based and Community Organizations, (67 FR 77141).

72. SPECIAL CONDITIONS – TEXAS GENERAL LAND OFFICE (GLO)

If applicable to a Project or Activity, Subrecipient must be in compliance with the following Special Conditions and any other State, Federal, or local laws, rules, and regulations as may be applicable, throughout the term of the Contract, prior to the release of any grant funds for the Projects or Activities anticipated.

Subrecipient is deemed to have read and to understand the requirements of each of the following, if applicable to the Project or any Activity under this Contract:

A. REIMBURSEMENT, GENERALLY

As provided for in Public Law 115-56, the Contract funds may not be used for activities that are eligible to be reimbursed by, or for which funds are made available by, (a) the Federal Emergency Management Agency (FEMA); (b) the Army Corps of Engineers (Corps); (c) any other federal funding source; or (d) covered by insurance, and Subrecipient shall ensure compliance with all such requirements.

GENERAL PROVISIONS

REQUEST FOR PROPOSALS MENTAL HEALTH COURT PUBLIC DEFENDER'S OFFICE BUILDOUT GALVESTON COUNTY, TEXAS

B. NATIONAL FLOOD INSURANCE PROGRAM COMPLIANCE

- (1) Subrecipient must provide documentation which indicates they have received approval from the Texas Water Development Board (TWDB), the National Flood Insurance Program (NFIP) State Coordinating Agency, that appropriate ordinances or orders necessary for Subrecipient to be eligible to participate in the NFIP have been adopted.
- (2) Where Activities specified in a Performance Statement, involve structures that are located in Special Flood Hazard Areas (SFHA), flood insurance may be required, and Subrecipient shall obtain such insurance, and shall maintain documentation evidencing compliance with such requirements.
- (3) Subrecipient acknowledges and agrees that if any property that is the subject of an Activity under this Contract located within a floodplain, that the following terms and conditions shall apply:
 - a. Under the Flood Disaster Protection Act of 1973, as amended (42 U.S.C. 4001-4128), Federal financial assistance for acquisition and construction purposes (including rehabilitation) may not be used in an area identified by the Federal Emergency Management Agency (FEMA) as having special flood hazards, unless:
 - i. The community in which the area is situated is participating in the National Flood Insurance Program ("NFIP") (44 CFR parts 59 through 79), or less than one (1) year has passed since the FEMA notification regarding such hazards; and
 - ii. The community is participating in the NFIP, or that flood insurance protection is to be obtained as a condition of the approval of financial assistance to the property owner.
 - b. Where the community is participating in the NFIP and the recipient provides financial assistance for acquisition or construction purposes (including rehabilitation) for property located in an area identified by FEMA as having special flood hazards, Subrecipient is responsible for ensuring that flood insurance under the NFIP is obtained and maintained.
 - c. Under Section 582 of the National Flood Insurance Reform Act of 1994, 42 U.S.C. 515a, HUD disaster assistance that is made available in a special flood hazard area may not be used to make a payment (including any loan assistance payment) to a person for repair, replacement, or restoration for flood damage to any personal, residential, or commercial property if:
 - i. The person had previously received Federal flood disaster assistance conditioned on obtaining and maintaining flood insurance; and
 - ii. The person failed to obtain and maintain flood insurance.
 - d. Subrecipient understands and agrees that it has a responsibility to inform homeowners receiving disaster assistance that triggers the flood insurance purchase requirement of their statutory responsibility to notify any transferee of the requirement to obtain and maintain flood insurance, and that the transferring owner may be liable if he or she fails to do so.

C. PROJECT MAPPING/DESIGN INFORMATION

For construction projects, Subrecipient shall require and maintain copies, in written and/or digital format, of final Project record drawing(s) and engineering schematics, as constructed.

GENERAL PROVISIONS

REQUEST FOR PROPOSALS MENTAL HEALTH COURT PUBLIC DEFENDER'S OFFICE BUILDOUT GALVESTON COUNTY, TEXAS

D. WATER SYSTEM IMPROVEMENTS

- (1) Prior to the GLO's release of funds for the construction of any water system improvements, Subrecipient shall provide certification to the GLO that plans, specifications, and related documents for the specified water system improvements have been prepared by the engineer selected for such activities, or the engineer's duly authorized representative, and that the review of such plans, specifications, and related documents meet the applicable Texas Commission on Environmental Quality (TCEQ) review requirements described in Title 30 of the Texas Administrative Code.
- (2) Prior to construction, Subrecipient shall provide documentation to the GLO that an approved new or amended Certificate of Convenience and Necessity (CCN), or the equivalent permit or authority for the area to be served, has been issued by the TCEQ.
- (3) Prior to Subrecipient submission of the Project Completion Report for any water system improvements described in Attachment A, Subrecipient shall provide a letter from the TCEQ that the constructed well is approved for interim use and may be temporarily placed into service pursuant to 30 Texas Administrative Code, Chapter 290—Rules and Regulations for Public Water Systems.

E. SEWER SYSTEM IMPROVEMENTS

Prior to the construction of any sewer system improvements described, Subrecipient shall provide certification that plans, specifications, and related documents for the specified sewer system improvements have been prepared by the engineer selected for such activities, or the engineer's duly authorized representative, and that the review of such plans, specifications, and related documents meet the Texas Commission on Environmental Quality (TCEQ) review requirements described in 30 Texas Administrative Code, Chapter 217, Subchapter D.

Further, prior to the construction of any sewer lines or additional service connections described in Attachment A, Subrecipient shall provide notification of the start of construction on any sewer treatment plant of other system-related improvements included in this Contract.

F. WASTEWATER TREATMENT CONSTRUCTION

Prior to incurring costs for any wastewater treatment construction in Attachment A, Subrecipient shall provide documentation of an approved permit or amendment(s) to an existing permit for such activities from the TCEQ's Water Quality Division.

In addition, Subrecipient shall provide documentation to the GLO that an approved new or amended Certificate of Convenience and Necessity (CCN), or equivalent permit or authority for the area to be served has been issued by the TCEQ.

G. SEPTIC SYSTEM IMPROVEMENTS

- (1) Subrecipient shall provide documentation that final plans, specifications, and installation of its septic system improvements have been reviewed and approved by the City or County Health Department through authority granted by the TCEQ.
- (2) Subrecipient shall mitigate all existing septic systems in accordance with 30 Texas Administrative Code Chapter 285, Subchapter D, §285.36(b), which states, "All tanks, boreholes, cesspools, seepage pits, holding tanks, and pump tanks shall have the wastewater removed by a waste transporter, holding a current registration with the executive director. All tanks, boreholes, cesspools, seepage pits, holding tanks, and pump tanks shall be filled to ground level with fill material (less than three inches in diameter), which is free of organic and construction debris."
- (3) Prior to the selection of program recipients for proposed On-Site Sewer Facilities (OSSF), Subrecipient shall provide a copy of its proposed program guidelines to for GLO review. All proposed

GENERAL PROVISIONS
REQUEST FOR PROPOSALS
MENTAL HEALTH COURT PUBLIC DEFENDER'S OFFICE BUILDOUT
GALVESTON COUNTY, TEXAS

OSSF programs must meet or exceed guidelines set forth in 30 Texas Administrative Code Chapter 285 Subchapter D.

H. BUILDING CONSTRUCTION

Subrecipient shall provide documentation that the construction of a new building and facilities are in compliance with the Texas Accessibility Standards (TAS) of the Architectural Barriers Act, Chapter 469, Texas Government Code, and the Texas Department of Licensing and Regulation (TDLR) Architectural Barriers Administrative Rules, 16 Texas Administrative Code, Part 4, Chapter 68. If estimated construction costs exceed Fifty Thousand Dollars (\$50,000.00), Construction Documents must be submitted to the Texas Department of Licensing and Regulation (TDLR) for an accessibility plan review.

I. BRIDGE CONSTRUCTION/REHABILITATION

Subrecipient shall use the minimum design requirements of the Texas Department of Transportation (TxDOT) for bridge construction/rehabilitation. Final plans and specifications must be submitted to TxDOT for review and approval prior to the start of construction, and documentation of such approval must be provided to the GLO.

J. DISASTER SHELTERS

Subrecipient shall ensure that the primary purpose of the facility, as described in Attachment A, is to serve as a disaster shelter, and shall ensure the facility is operated at all times in a manner that ensures that the priority use is to serve as a disaster shelter regardless of any other scheduled uses or commitments that existed at the time of the disaster or emergency situation. In addition, Subrecipient shall prepare or be incorporated into an approved emergency management plan, as prescribed by the Texas Division of Emergency Management, identifying the shelter as a facility that provides short-term lodging for evacuees during and immediately after an emergency situation. Subrecipient shall submit a copy of Subrecipient's Emergency Management Plan Annex for Shelter and Mass Care to the GLO.

K. DEBRIS REMOVAL

Subrecipient shall ensure that any debris to be removed consists primarily of vegetation, construction and demolition materials from damaged or destroyed structures, and personal property. Only debris identified as the responsibility of the local jurisdiction will be eligible for the reimbursement of cost of removal.

Prior to beginning debris collection operations, Subrecipient shall address all pertinent environmental concerns, adhere to all applicable regulations, and obtain all required permits. Further, Subrecipient shall adhere to the methods described herein for the collection and storage of debris prior to proper disposal.

While construction and demolition debris may be collected and disposed of at an appropriately rated landfill, woody and/or vegetative debris must be stored prior to disposal by use of temporary debris storage and reduction sites (TDSR). Subrecipient will prepare and operate the TDSR sites, or local jurisdictions choosing to conduct their own debris operations may review Chapter 7 of the FEMA Debris Management Guide regarding the use of TDSR sites. This document may be obtained <https://www.fema.gov/pdf/government/grant/pa/demagde.pdf>.

In order to maintain the life expectancy of landfills, Subrecipients disposing of woody and/or vegetative debris must choose burning, chipping, or grinding as the method of disposal. Any project disposing of woody and/or vegetative debris must be approved in writing by the GLO.

L. USE OF BONDS

Subrecipient must notify the GLO of its issuance and sale of bonds for completion of the project funded under this Contract.

GENERAL PROVISIONS

REQUEST FOR PROPOSALS MENTAL HEALTH COURT PUBLIC DEFENDER'S OFFICE BUILDOUT GALVESTON COUNTY, TEXAS

M. PROGRAM GUIDELINES

Prior to the selection of program beneficiaries, Subrecipient shall provide to the GLO, for GLO review and approval, a copy of its proposed guidelines for the program. The guidelines must meet or exceed to requirements in the Federal Registers. The guidelines must include provisions for compliance with the Federal Fire Prevention and Control Act of 1974 (which requires that any housing unit rehabilitated with grant funds be protected by a hard-wired or battery-operated smoke detector) and provisions for compliance with 24 CFR 35 (HUD lead-based paint regulation).

N. AFFORDABILITY PERIODS FOR SINGLE-FAMILY HOUSING REHABILITATION, RECONSTRUCTION, OR NEW CONSTRUCTION ASSISTANCE:

For single-family non-rental housing assistance provided by Subrecipient, Subrecipient shall implement the following affordability period: for rehabilitation or reconstruction of housing projects, a minimum¹ three-year affordability period guaranteed by an unsecured forgivable promissory note and for new construction housing projects, a minimum[□] five-year affordability period guaranteed by an unsecured forgivable promissory note.

O. UNSECURED FORGIVABLE PROMISSORY NOTE ("NOTE")

An unsecured forgivable promissory note shall be issued at an interest rate of zero-percent (0%). Provided that all terms and conditions contained in the Note continue to be fulfilled, a Note will be forgiven according to the following terms, as applicable, until the applicant fulfills their note requirement (the requirements are defined in the promissory note document): for a three-year Note, at a rate of 33 percent per year, for the first two years, and 34 percent after the third year; and for a five-year Note, at a rate of 20% per year.

- (1) If the homeowner occupies the home for the full Note term, the Note expires and no repayment is required, nor will any conditions be imposed relative to the disposition of the property. If any of the terms and conditions under which the assistance was provided are breached or if the property is sold, leased, transferred, or vacated by the homeowner for any consecutive thirty (30) day period during the Note term, the repayment provisions of the promissory note and DOT shall be enforced.
- (2) If, during the Note term, the homeowner vacates the unit for any consecutive thirty (30) day period, the locality may forgive, as evidenced by the program director, city council, or commissioner court action, the remaining loan balance. Prior to forgiveness of all or any portion of the assistance provided, the request for forgiveness must be approved by the local governing body and be based on documented and justifiable conditions or circumstances that would result in an unnecessary hardship to the homeowner and the determination that the national objective of benefiting low to moderate-income persons was met.
- (3) The national objective will be considered met only when the program director, city council, or county commissioners court determines that a low- to moderate-income person has occupied the rehabilitated or reconstructed home for a time sufficient to meet the national objective. If the national objective was not achieved, Subrecipient is liable for repayment of an amount equal to the difference in the appraised value of the home prior to reconstruction and the sales price when the home is sold during the term of the forgivable Note.
- (4) If the property is sold or transferred to a person other than an eligible LMI person, the remaining prorated balance of the DPL must be repaid by the Subrecipient from the sales proceeds. Notwithstanding the preceding, Subrecipient shall be held liable for any balance remaining over and above the sales proceeds. In all instances, upon completion of the Note or repayment of the assistance (in full or in

GENERAL PROVISIONS

REQUEST FOR PROPOSALS MENTAL HEALTH COURT PUBLIC DEFENDER'S OFFICE BUILDOUT GALVESTON COUNTY, TEXAS

part), the Subrecipient shall prepare and record a release of lien document in the land records of the applicable county.

- (5) Monitoring of the Note is performed during and after the grant is closed. Subrecipient must utilize non-CDBG-DR funds to fulfill the monitoring obligations for its impacted recovered community.
- (6) The subrecipient will maintain a list of homeowners that do not maintain flood insurance as documented in their promissory note. These applicants will not be allowed to received future assistance as outlined in Section B of this document.

P. RENTAL HOUSING REHABILITATION, RECONSTRUCTION, OR NEW CONSTRUCTION ASSISTANCE

The rental housing assistance will provided be provided in the following forms: for rehabilitation or reconstruction of multi-family rental projects with eight or more units, a minimum fifteen (15) year forgivable loan or grant at zero interest; and for new construction multi-family rental projects with five or more units, a minimum twenty (20) year forgivable loan or grant at zero interest. Provided all terms and conditions under which the assistance was provided continue to be fulfilled, the note will be forgiven at a rate of 5 percent per year until the applicant fulfills their note requirement (the requirements are defined in the promissory note document).

The purpose of the program is to facilitate the rehabilitation, reconstruction, and/or new construction of affordable rental housing needs within the service area of the disaster event. A minimum of 51% of the multi-family units must be restricted during the affordability period of twenty (20) years for low to moderate income (LMI) persons. The rents, at a minimum, must comply with High HOME Investment Partnership (HOME) Rents and other existing Land Use Restriction Agreement (LURA) restrictions if applicable. HOME rent limits are defined by HUD and must equal the lesser of fair market rents or 30% of the adjusted income for people earning 65% of the AMFI.

Q. COASTAL MANAGEMENT

Subrecipient acknowledges and agrees that any Project that may impact a Coastal Natural Resource Area must be consistent with the goals and policies of the Texas Coastal Management Program as described in 31 Texas Administrative Code, Part 16, Chapter 501.

73. ENERGY EFFICIENCY (42 U.S.C. 6201 and 2 CFR 200 APPENDIX II (H))

Contractor must comply with the mandatory standards and policies relating to energy efficiency, which are contained in the state energy conservation plan issued in compliance with the Energy Policy and Conservation Act (42 U.S.C. 6201). Contractor must include this provision in all contracts between itself and any subcontractors in connection with the services performed under this Contract.

74. LEAD AND ASBESTOS

If this Request for Proposal involves remediation, demolition, reconstruction, rehabilitation, repair, or construction, or other applicable activities, the Contractor shall be responsible for performing investigations of lead and asbestos containing materials, and any required lead and asbestos abatement in compliance with Federal, State, and local laws, rules, regulations, ordinances and orders, relating to lead abatement and asbestos abatement as applicable, including but not limited to the Texas Asbestos Health Protection Act, codified as Chapter 1954 of the Occupations Code; the Texas Asbestos Health Protection Regulations, located at Title 25, Part 1, Chapter 295, Subchapter C of the Texas Administrative Code; Chapter 1955 of the Texas Occupations Code (lead-based paint abatement); the Texas Environmental Lead Reduction regulations, located at Title 25, Part 1, Chapter 295, Subchapter I of the Texas Administrative Code; the federal National Emission Standards for Asbestos regulations, located at Title 40, Part 61,

GENERAL PROVISIONS

REQUEST FOR PROPOSALS MENTAL HEALTH COURT PUBLIC DEFENDER'S OFFICE BUILDOUT GALVESTON COUNTY, TEXAS

Subpart M of the Code of Federal Regulations, and the National Emission Standards for Hazardous Air Pollutants. Contractor shall perform such inspections, encapsulation, remediation, or other actions as required by federal, State, or local requirements in accordance with the federal Environmental Protection Agency (EPA), Texas Department of State Health Services (TXDSHS), and Texas Commission on Environmental Quality (TCEQ) requirements.

75. USE OF DHS SEAL, LOGO, AND FLAGS PROHIBITED WITHOUT PRIOR APPROVAL

Contractor must obtain permission from the U.S. Department of Homeland Security financial assistance office (DHS FAO) **prior** to using DHS seals(s), logos, crests, or reproductions of flags or likenesses of DHS agency officials, including use of the United States Coast Guard seal, logo, crests or reproductions of flags or likenesses of Coast Guard Officials.

76. FEDERAL GOVERNMENT NOT A PARTY

Contractor acknowledges that the Federal Government is not a party to the contract and is not subject to any obligations or liabilities to Galveston County, contractor, or any other party pertaining to any matter resulting from the contract.

77. PROGRAM FRAUD AND FALSE OR FRAUDULENT STATEMENTS OR RELATED ACTS

In contracts funded through Federal grants, Contractor acknowledges that 31 U.S.C. Chapter 38, Administrative Remedies for False Claims and Statements (31 U.S.C. § 3801, et seq.) and the implementing regulations thereunder, 49 C.F.R. Part 79, apply to Contractors actions pertaining to the contract.

78. ACKNOWLEDGMENT OF GOVERNMENT RECORD

Responder acknowledges that its submission in this Request for Proposals, including its RFP, certifications, affidavits, Vendor Forms (i.e., PEID, W-9, CIQ, etc.) constitutes government records under Chapter 37 of the Texas Penal Code.

79. COMPLIANCE WITH GALVESTON COUNTY PURCHASING POLICIES AND PROCEDURES

Responder acknowledges, by its submission in this Request for Proposals, that it shall comply with the Galveston County Purchasing Policies & Procedures Manual approved by Order of the Galveston County Commissioners' Court on March 7, 2018.

80. ENTIRETY OF AGREEMENT AND MODIFICATION

This contract contains the entire agreement between the parties. Any prior agreement, promise, negotiation, or representation not expressly set forth in this contract has no force or effect. Any subsequent modification to this contract must be in writing, signed by both parties.

An official representative, employee, or agent of the County does not have the authority to modify or amend this contract except pursuant to specific authority to do so granted by the Galveston County Commissioners' Court.

81. NOTICE

All notices or other communications required or permitted under this contract shall be in writing and shall be deemed to have been duly given if delivered personally in hand, transmitted by facsimile, or mailed certified mail, return receipt

GENERAL PROVISIONS

**REQUEST FOR PROPOSALS
MENTAL HEALTH COURT PUBLIC DEFENDER'S OFFICE BUILDOUT
GALVESTON COUNTY, TEXAS**

requested with proper postage affixed and addressed to the appropriate party at the following address or at such other address as may have been previously given in writing to the parties (Responder shall provide its notice information with its RFP submission). If mailed, the notice shall be deemed delivered when actually received, or if earlier, on the third day following deposit in a United States Postal Service post office or receptacle, duly certified, return receipt requested, with proper postage affixed. If delivered in person, notice shall be deemed delivered when receipted for by, or actually received by the receiving Party. If transmitted by facsimile, notice shall be deemed delivered when receipt of such transmission is acknowledged.

To the County at:

Hon. Mark Henry,
County Judge of Galveston County
722 Moody (21st Street), Second (2nd) Floor
Galveston, Texas 77550
Fax: (409) 765-2653

With copies to:

Rufus Crowder, CPPO CPPB,
Galveston County Purchasing Agent
722 Moody (21st Street), Fifth (5th) Floor
Galveston, Texas 77550
Fax: (409) 621-7997

To the Contractor at:

SPECIAL PROVISIONS

**REQUEST FOR PROPOSAL
MENTAL HEALTH COURT PUBLIC DEFENDER’S OFFICE BUILDOUT
GALVESTON COUNTY, TEXAS**

TABLE OF CONTENTS

A. PURPOSE2
C. PROCUREMENT TIMELINE2
D. PRE-PROPOSAL CONFERENCE3
F. PROPOSAL SURETY3
G. PERFORMANCE AND PAYMENT BONDS3
H. BEST AND FINAL OFFERS (BAFO)3
I. DAVIS-BACON WAGE RATES3
J. PERSONNEL TO CONTACT3
K. PROGRAM ADMINISTRATION & CONTRACT MANAGEMENT4
L. INSURANCE5
M. SCOPE OF WORK – PROJECT SPECIFICATIONS6
N. AWARD PRICES6
O. INVOICES:6
P. SAFETY:6
Q. CONSULTATION:7
R. REQUIREMENTS OF REQUEST FOR PROPOSAL7
S. EVALUATION AND SELECTION PROCESS7
SPECIAL PROVISIONS FOR CONSTRUCTION12
CONTRACT AWARD30

SPECIAL PROVISIONS

REQUEST FOR PROPOSAL MENTAL HEALTH COURT PUBLIC DEFENDER'S OFFICE BUILDOUT GALVESTON COUNTY, TEXAS

The General Provisions and the Special Provisions of this Request for Qualification and the Exhibits attached hereto are made a part of this agreement between the Parties. In the event of a conflict between the General Provisions and the Special Provisions, the terms of the Special Provisions shall control.

A. PURPOSE

Galveston County is seeking a contractor to remodel the former Housing Department Suite on the 6th Floor of the Galveston County Courthouse, 722 Moody (21st Street), Galveston TX 77550.

B. EXCEPTIONS

Any exceptions to these solicitation conditions should be listed on a separated sheet of paper, attached to respondent's submittal, and submitted with response at the specified date and time of the solicitation opening.

C. PROCUREMENT TIMELINE

A timeline for this solicitation and initial process is included below. Galveston County reserves the right to change these dates and will notify Respondents of any changes:

Advertise RFP (first date of publication)	Thursday, October 21, 2021
Advertise RFP (second date of publication)	Thursday, October 28, 2021
Deadline for Questions & Inquiries	Monday, November 8, 2021, by 5:00 p.m.
Proposals due from proposers/RFP Opening	Thursday, November 18, 2021, at 2:15 p.m.

Interested parties may attend the Thursday, November 18, 2021 2:15 p.m.. bid opening virtually by using the following link:

<https://galvestoncountytexas.webex.com/galvestoncountytexas/j.php?MTID=mb7bcfc438ea82c165814609ccde76c28>

Join by meeting number

Meeting number (access code): 2487 440 7765

Meeting password: B221004

Tap to join from a mobile device (attendees only)
+1-415-655-0001,,24874407765## US Toll

Join by phone
+1-415-655-0001 US Toll
Global call-in numbers

Join from a video system or application
Dial 24874407765@galvestoncountytexas.webex.com

You can also dial 173.243.2.68 and enter your meeting number.

SPECIAL PROVISIONS

**REQUEST FOR PROPOSAL
MENTAL HEALTH COURT PUBLIC DEFENDER'S OFFICE BUILDOUT
GALVESTON COUNTY, TEXAS**

D. PRE-PROPOSAL CONFERENCE

No pre-proposal is scheduled for this project.

E. SUBMISSION INSTRUCTIONS:

One (1) unbound original proposal, six (6) proposal copies, must be submitted no later than **2:15 P.M. CST**, on **Thursday, November 18, 2021**, to the following:

**Rufus G. Crowder, CPPO CPPB
Purchasing Agent
County of Galveston
722 Moody Avenue (21st Street), Fifth (5th) Floor
Galveston, TX 77550**

The time stamp clock located in the Purchasing Agent's office shall serve as the official time keeping piece for this solicitation process. Any proposals received after **2:15 P.M. CST** on the specified date will be returned unopened.

Proposal Specifications can be obtained at the office of the Galveston County Purchasing Agent, located in the Galveston County Courthouse, 722 Moody, (21st Street), Floor 5, Purchasing, Galveston, Texas 77550, or by visiting the Galveston County website @ <http://www.galvestoncountytexas.gov/pu/Pages/OpenSolicitations.aspx>

F. PROPOSAL SURETY

A surety/bond is a requirement of this solicitation.

G. PERFORMANCE AND PAYMENT BONDS

Performance and Payment Bonds are requirements of this solicitation.

H. BEST AND FINAL OFFERS (BAFO)

The Best and Final Offer process is applicable to this solicitation.

I. DAVIS-BACON WAGE RATES

Attention is called to the fact that not less than, the federally determined prevailing (Davis-Bacon and Related Acts) wage rate, as issued by the Office of Rural Community Affairs and contained in the contract documents, must be paid on this project. In addition, the successful Responder must ensure that employees and applicants for employment are not discriminated against because of race, color, religion, sex age or national origin.

J. PERSONNEL TO CONTACT

Respondents desiring an explanation or interpretation relative to this solicitation must request it in writing. Oral explanations or instructions will not be binding. Any information given to a Respondent, which in the opinion of the County affects all Respondents or would be prejudicial to other Respondents if not communicated, shall be furnished to all Respondents as an addendum to the solicitation. Respondents **must** direct all inquiries to the following:

SPECIAL PROVISIONS
REQUEST FOR PROPOSAL
MENTAL HEALTH COURT PUBLIC DEFENDER'S OFFICE BUILDOUT
GALVESTON COUNTY, TEXAS

Rufus G. Crowder, CPPO CPPB
Purchasing Agent
722 21st Street (Moody)
Galveston, Texas 77550
e-mail: purchasing.bids@co.galveston.tx.us

Respondents must e-mail their requests (with the subject line “**Mental Health Court Public Defender’s Office Buildout – RFP #B221004– Questions**”) for additional information and/or clarification to the address listed above. The request must include the Responder’s name and the solicitation number and title.

*Any request for additional information or clarification must be received in writing **no later than ten (10) calendar days prior to the solicitation due date.*** Late requests or those not delivered to the proper address may not receive a reply. Respondents shall not attempt to contact the County by any other means. The Purchasing Agent shall post the answers on the County website from the procurement web page and via addendum.

The County will issue responses to inquiries and any other corrections or amendments, it deems necessary, in the form of a written addendum, issued prior to the solicitation Submission Deadline / Solicitation Opening date. The County, at its sole discretion, may not issue a response to an RFI submittal. Respondents should not rely on any oral or written representations, statements, or explanations, other than those made in this solicitation or in any written addendum to this solicitation. Where there appears to be conflict between the solicitation and any issued addenda, the last addendum issued will prevail.

Addenda will be posted and made available on the County’s procurement web page. **It is the Responder’s sole responsibility to ensure receipt of all addenda prior to submitting its response.** All Respondents should check the County’s procurement web page for all addenda prior to submitting a response. The County’s procurement web page is located at www.galvestoncountytexas.gov/pu/Pages/OpenSolicitations.aspx.

The Responder must acknowledge the receipt of all addenda on the forms provided. In the event a Responder fails to acknowledge receipt of such addenda, the County may, at its sole discretion, determine that such failure to acknowledge any or all addenda does not materially affect the solicitation and waive the acknowledgement of one or more addenda.

Respondents who submit inquiries *after* the deadline date for receipt of questions indicated on the Procurement Timeline, risk that its response in the procurement will not be responsive or competitive because the County is not able to respond before the solicitation receipt date or in sufficient time for the Responder to prepare a responsive or competitive submittal.

All questions and responses as posted on the County website pertaining to this solicitation are considered an addendum to, and part of, this solicitation. Each Responder shall be responsible to monitor the County website for new or revised solicitation information. The County shall not be bound by any verbal information, nor shall it be bound by any written information that is not either contained within the solicitation or formally issued as an addendum by the Purchasing Agent.

K. PROGRAM ADMINISTRATION & CONTRACT MANAGEMENT

The County of Galveston has a designated Program Administrators that will manage the work to be performed under the resultant contract, who for the purpose of this RFP is:

SPECIAL PROVISIONS

REQUEST FOR PROPOSAL MENTAL HEALTH COURT PUBLIC DEFENDER'S OFFICE BUILDOUT GALVESTON COUNTY, TEXAS

William (Will) Riordan
Facilities Director
722 Moody, 6th Floor
Galveston, TX 77550

The Galveston County Commissioners' Court, and/or authorized designees will be responsible for negotiating with the successful Vendor the scope of work, the standards of performance, the specific technology provided, and the support services required for the proposed projects. All contractual amendments will be processed in accordance with Galveston County Purchasing Policies. Amendments will also be brought to Galveston County Commissioners Court for approval as deemed necessary. The approval process serves to ensure the project technology and/or service is within the scope of the resultant contract, and that pricing meets the agreed upon pricing methodology as specified in the contract, and that funds are available.

L. INSURANCE

Responder must submit, with its response, a current certificate of insurance evidencing coverage in the amounts specified below or greater. In lieu of submitting a certificate of insurance, Respondents may submit a notarized statement from an insurance company authorized to conduct business in the State of Texas guaranteeing that Respondent has such insurance. Provided however, that successful Respondent(s) shall be required to provide a current certificate of insurance to the Galveston County Purchasing Agent's Office before Respondent commences any work hereunder. **Insurance shall be placed with insurers having an A.M. Best's rating of no less than A.** Such insurance must be issued by a casualty company authorized to do business in the State of Texas, and in standard form approved by the Board of Insurance Commissioners of the State of Texas, with coverage provisions ensuring the public from loss or damage that may arise to any person or property by reason of services rendered by Contractor.

Galveston County shall be listed as an additional insured on each policy and all certificates of insurance and Contractor shall provide Galveston County with no less than thirty (30) calendar days prior notice of any changes to the policy during the contractual period.

Certificates of Insurance, fully executed by a licensed representative of the insurance company written or countersigned by an authorized Texas state agency, shall be filed with the County Purchasing Agent within ten (10) calendar days of the execution of this Agreement as written proof of such insurance and further provided that Contractor shall not commence work under this Agreement until Contractor has obtained all insurance required herein, provided written proof as required herein, and received written notice to proceed issued from the County Purchasing Agent. **Failure to provide such evidence of insurance within the ten (10) calendar day period shall constitute an event of default.**

Workers' Compensation Insurance. Respondent shall carry in full force Workers' Compensation Insurance Policy(ies), if there is more than one employee, for all its employees, including but not limited to full time, part time, and emergency employees employed by the Contractor.

Commercial General Liability. Respondent shall carry in full force commercial general liability insurance with a limit of not less than \$1,000,000 each occurrence and \$2,000,000 in the aggregate. The Policy shall, minimally, cover liability for bodily injury, personal injury, and property damage.

Business Automobile Liability. Respondent shall carry in full force business automobile liability coverage with a combined bodily injury/property damage limit of not less than \$1,000,000 each accident. The policy shall cover liability arising from the operation of licensed vehicles by policyholder.

SPECIAL PROVISIONS

REQUEST FOR PROPOSAL MENTAL HEALTH COURT PUBLIC DEFENDER'S OFFICE BUILDOUT GALVESTON COUNTY, TEXAS

Subrogation Waiver. Contractor and Contractor's insurance carrier shall waive any and all rights to subrogation against Galveston County in regard to any suit or claim arising out of personal injury or property damage resulting from Contractor's performance under this Agreement.

M. SCOPE OF WORK – PROJECT SPECIFICATIONS

Please reference the project manual area for detailed specifications.

N. AWARD PRICES

Award prices include all royalties and costs arising from patents, trademarks, and copyrights in any way involved in the work. Whenever the Awardee is required or desires to use any design, device, material or process covered by letters of patent or copyright, the Awardee shall indemnify and save harmless the County, its officers, agents and employees from any and all claims for infringement by reason of the use of any such patented design, tool, material, equipment, or process, to be performed under the contract, and shall indemnify the County its officers, agents, and employees for any costs, expenses and damages which may be incurred by reason of any infringement at any time during the prosecution or after the completion of the work.

O. INVOICES:

Invoices must be itemized indicating all materials and supplies used. Invoices must be submitted to:

**Galveston County Auditor's Office
Attn: Accounts Payable
P.O. Box 1418
Galveston, Texas 77553**

Failure to submit invoices to the above address or failure to include the Purchase Order Number will result in delay in payment.

Contractor must accept purchase order numbers for specified supplies, equipment, and/or services. Contractor shall not perform any work or release any supplies and/or equipment to any authorized representative of the County of Galveston unless a valid purchase order number issued by the office of the Galveston County Purchasing Agent accompanies the order or if vendor can comply with the provision as stated in the General Provisions, page 5, item 13, Procurement Card Program.

Payment for any items issued without prior receipt of a valid purchase order number may become the sole responsibility of the successful contractor.

P. SAFETY:

All prospective bidders will need to provide their OSHA 300 logs for the past three (3) years, display work crew safety training logs and safety policies and procedures for RFP committee purview. Safety is a primary concern of the county and the awardee will be required to follow all relevant OSHA Code of Federal Regulations regarding workplace safety. Violations of safety protocol will be addressed by the County Risk Manager and could lead to construction delays and possible termination of the contract.

SPECIAL PROVISIONS

REQUEST FOR PROPOSAL MENTAL HEALTH COURT PUBLIC DEFENDER'S OFFICE BUILDOUT GALVESTON COUNTY, TEXAS

Q. CONSULTATION:

Upon completion of site visit and inspection the bidder should provide information regarding the most advantageous methodology, solution, services, supplies, delivery and counsel in order to insure successful completion of this project. The ability of the bidder to inform and consult on the conditions of the equipment as well as work plan, starting, and finishing time will be heavily weighed and considered by the RFP evaluation committee.

R. REQUIREMENTS OF REQUEST FOR PROPOSAL

Respondent shall provide one (1) original and six (6) hard copies of its response, to the Purchasing Agent on or before the submission deadline specified herein. Font size is limited to no smaller than font size 11, except that organizational charts, other graphics, and footers may be as small as font size 9.

S. EVALUATION AND SELECTION PROCESS

The award(s) will be made to the responsible proposer(s) whose proposal is determined to be the best evaluated offer demonstrating the best ability to fulfill the requirements set forth in this Request for Proposal. In awarding the contract, the Evaluation Committee may take into consideration the proposer's skill, capacity, experience, support capabilities, previous work record, costs, the necessity of prompt and efficient completion of work described in the proposal documents, or other factors considered relevant.

The evaluation committee shall review and evaluate the responses timely submitted to the County Purchasing Agent resulting from this solicitation effort. Responses shall be reviewed by the evaluation committee and shall be evaluated in accordance with the evaluation criteria listed herein. The evaluation committee will determine which responses are qualified based on the criteria listed below. The evaluation committee shall evaluate and score each response. The points from each scoring category will be comprised from the following:

Reputation of the Respondent and of the Respondent's Goods and Services – 20%

1. General History

- 1.1 How many years has your organization been in business as a General Contractor?
- 1.2 How many years has your organization been in business under its present business name?
 - 1.2.1 Under what other or former names has your organization operated?
 - 1.2.2 Please describe the organization of your company (e.g., corporation, limited liability company, partnership, etc.) and name all principals, partners, officers and/or, in the case of a sole proprietorship, owners.

2. Licensing

- 2.1 Please provide a list of jurisdictions and trade categories in which your organization is legally qualified to do business, and indicate registration or license numbers, if applicable.
- 2.2 Please provide a list of jurisdictions in which your organization, partnership or trade name is filed.

3. Experience

- 3.1 Please provide a list of the categories of work that your organization normally performs with its own forces.
- 3.2 Claims and Suits. (If the answer to any of the questions below is yes, please provide details.)

3.2.1 Has your organization ever failed to complete any work awarded to

SPECIAL PROVISIONS

REQUEST FOR PROPOSAL MENTAL HEALTH COURT PUBLIC DEFENDER'S OFFICE BUILDOUT GALVESTON COUNTY, TEXAS

- 3.2.2 Please describe any judgments, claims, litigation, arbitration or mediation proceedings or suits pending, outstanding or closed against your organization or its officers within the last ten (10) years.
- 3.2.3 Please describe any lawsuits, requested arbitration or mediation with regard to construction contracts your firm may have filed within the last ten (10) years.
- 3.2.4 Please describe any outstanding unresolved claims.
- 3.3 Within the last ten (10) years, has any officer or principal of your organization ever been an officer or principal of another organization when it failed to complete a construction contract? (If the answer is yes, please attach details.)
- 3.4 Please state annual amount of construction work performed by this organization for each of the past five (5) years.
- 3.5 Describe the major construction projects your organization has completed in the past five (5) years, giving the name and location of project, owner, architect, original and final contract amount, scheduled and actual date of completion and percentage of the cost of the work performed with your own forces.
- 3.6 Describe the major construction projects your organization has in progress, giving the name and location of project, owner, architect, staff assigned to the projects, construction contract amount, percentage complete and scheduled completion date.
- 3.7 Please provide total worth of work (1) in progress and (2) under contract.
- 3.8 Describe the projects, if any, of a similar scope that your organization has completed for a municipality or other government entity in the last ten (10) years, giving the name and location of project, owner, developer, architect, staff members and management assigned to projects, construction contract amount, date of completion and percentage of the cost of the work performed with your own forces.

4. Narrative

4.1 Please provide, in 2000 words or less and on four (4) pages or less, a narrative that indicates your understanding of the Owner's needs, your knowledge of the elements involved in the project and the resources, methodologies and management philosophies that would be used for the project. Elements of the project construction such as timely scheduling, cost control, quality control and inspections, construction operations, and logistics should be addressed. The narrative should be concluded with a summary of the major features of your statement of qualifications and a statement analyzing the match between the your capabilities and the Owner's needs.

5. Testimonials

5.1 Please include up to three (3) one-page letters from public owners (professional references) with which you have worked on previous projects. These letters shall contain the original signature of the person writing the letter. Letters should comment on budget and/or scheduling experiences and qualitative matters related to services received from the contractor or joint venture participants.

SPECIAL PROVISIONS

REQUEST FOR PROPOSAL MENTAL HEALTH COURT PUBLIC DEFENDER'S OFFICE BUILDOUT GALVESTON COUNTY, TEXAS

6. References

6.1 Please include any other references from owners, architects and/or Architects with which you have worked on other projects.

7. Remarks

7.1 You may include up to two pages to address those issues which do not fall into any of the above categories or to expand on previous answers.

Quality of the Respondent's Goods or Services - (20 Points)

1. Personnel

1.1. Please provide an organizational chart that identifies, in detail, (1) key project personnel including project executive, project manager, assistant project manager(s), estimator, project superintendent and assistant superintendent(s) and (2) other company personnel that support the key project personnel. For key project personnel, indicate on or off site and what percentage of time you anticipate each person will devote to this project once construction begins.

1.2. Please provide resumes for key project personnel and include information regarding:

1.2.1. Education

1.2.2. Work History (by company), in reverse chronological order.

1.2.3. Project experience

1.2.3. Project experience, in reverse chronological order. Please list project name, contract amount, type and size of facility, owner, architect, Architect and capacity or position the key person served. Please note if the project was bid or negotiated.

2. Experience

2.1. Describe the experience of proposed key personnel with dispatch centers, police departments, data centers, governmental and institutional buildings over the last five (5) years. Note role proposed key personnel performed with listed projects and whether the project was negotiated or bid.

2.2. Describe the experience of proposed key personnel working together on prior projects.

2.3. List project experience, both organization and key personnel, in Baytown, Texas and with the City of Baytown and with PGAL, in the last ten (10) years.

2.4. State briefly the most pertinent considerations and challenges that must be addressed in the construction of a project of this type. You may wish to include sketches, diagrams, analyses, or other tools that will help you illustrate your firm's points.

2.5. Describe your organization's concepts for working in a team relationship with the Owner and Architect during the design and construction of major projects. State why you believe your team is best qualified to address the issues which are relevant to this project.

2.6. Briefly describe the methods and systems you will use to control the project in areas such as schedule, budget, information tracking and reporting, safety and quality.

SPECIAL PROVISIONS

REQUEST FOR PROPOSAL MENTAL HEALTH COURT PUBLIC DEFENDER'S OFFICE BUILDOUT GALVESTON COUNTY, TEXAS

Ability to Successfully and Timely Complete the Project - (20 Points)

1. Financial statement

1.1 Please provide a current financial statement, preferably audited, including your organization's latest balance sheet and income statement indicating the following information. This information will be kept confidential by the City if each page of the financial statement is clearly marked "confidential".

- Current Assets (e.g., cash, joint venture accounts, accounts receivable, notes receivable, accrued income, deposits, materials inventory and prepaid expenses);
- Net Fixed Assets;
- Other Assets;
- Current Liabilities (e.g., accounts payable, notes payable, accrued expenses, provision for income taxes, advances, accrued salaries and accrued payroll taxes);
- Other Liabilities (e.g., capital, capital stock, authorized and outstanding shares par values, earned surplus and retained earnings.)

1.2 Please provide name and address of firm preparing attached financial statement, and date thereof.

1.3 Please confirm that the included financial statement is for the organization named on page one. If it is not, please explain the relationship and financial responsibility of the organization whose financial statement is provided (e.g., parent-subsidiary).

1.4 Please indicate if the organization whose financial statement is attached will act as guarantor of the contract for construction.

2. Surety:

2.1 Please provide name of bonding company.

2.2 Please provide name and address of agent.

2.3 Please provide maximum bond amount available at this time.

2.4 Please provide your bond premium rate.

3. Insurance

3.1 Please provide name of insurance carrier or carriers.

3.2 Please provide name and address of agent.

3.2.1 Please provide a Certificate of Insurance for all coverages.

3.3 Please provide total amount of excess liability insurance coverage in place.

3.4 Please provide your general liability insurance rate.

SPECIAL PROVISIONS

REQUEST FOR PROPOSAL MENTAL HEALTH COURT PUBLIC DEFENDER'S OFFICE BUILDOUT GALVESTON COUNTY, TEXAS

4. **Claims and Suits**. (If the answer to any of the questions below is yes, please provide details.)
- 4.1 Has your organization ever failed to complete any work awarded to it?
 - 4.2 Please describe any judgments, claims, litigation, arbitration or mediation proceedings or suits pending, outstanding or closed against your organization or its officers within the last ten (10) years.
 - 4.3 Please describe any lawsuits, requested arbitration or mediation with regard to construction contracts your firm may have filed within the last ten (10) years.
 - 4.4 Please describe any outstanding unresolved claims.

Proposal Cost - Bid Amount - (40 Points)

- 1. Bid Proposal — include Bid Proposal, Conflict of Interest Questionnaire and Affidavit of Ownership or Control.

By the submission of its response to this solicitation, the Respondent accepts the requirements, formatting, and the evaluation process referenced herein.

The remainder of this page intentionally left blank

SPECIAL PROVISIONS
REQUEST FOR PROPOSAL
MENTAL HEALTH COURT PUBLIC DEFENDER'S OFFICE BUILDOUT
GALVESTON COUNTY, TEXAS



SPECIAL PROVISIONS FOR CONSTRUCTION

1. Contract and Contract Documents

- (a) The project to be constructed pursuant to this contract will be financed with assistance from FEMA and is subject to all applicable Federal and State laws and regulations.
- (b) The Plans, Specifications and Addenda, General Provisions shall form part of this contract and the provisions thereof shall be as binding upon the parties hereto as if they were herein fully set forth.

2. Definitions

Whenever used in any of the contract Documents, the following meanings shall be given to the terms here in defined:

- (a) The term "Contract" means the Contract executed between the County of Galveston, hereinafter called the Owner, and _____, hereinafter called Contractor, of which these GENERAL CONDITIONS, form a part.
- (b) The term "Project Area" means the area within which are the specified Contract limits of the Improvements contemplated to be constructed in whole or in part under this contract.
- (c) The term "Architect" means **PGAL, Inc.**, Architect in charge, serving the Owner with architectural or Architecting services, his successor, or any other person or persons, employed by the Owner for the purpose of directing or having in charge the work embraced in this Contract.
- (d) The term "Contract Documents" means and shall include the following: Invitation to Bid, , Signed Copy of Bid, General Conditions, Special Provisions For Construction, Acknowledgement and Certification Regarding Debarment, Non-Collusion Affidavit, Vendor Qualification Packet, Payment and Performance Bonds, Contract Award, Addenda (if any), Technical Specifications, and Drawings (as listed in the Schedule of Drawings).
- (e) The term "Substantially Complete" shall mean that the work is fully completed with the exception of minor miscellaneous work and adjustments.

SPECIAL PROVISIONS

REQUEST FOR PROPOSAL MENTAL HEALTH COURT PUBLIC DEFENDER'S OFFICE BUILDOUT GALVESTON COUNTY, TEXAS

3. Supervision by Contractor

- (a) Except where the Contractor is an individual and gives his personal supervision to the work, the Contractor shall provide a competent superintendent, satisfactory to the Local Public Agency and the Architect, on the work at all times during working hours with full authority to act for him. The Contractor shall also provide an adequate staff for the proper coordination and expediting of his work.
- (b) The Contractor shall lay out his own work and he shall be responsible for all work executed by him under the Contract. He shall verify all figures and elevations before proceeding with the work and will be held responsible for any error resulting from his failure to do so.

4. Subcontracts

- (a) The Contractor shall not execute an agreement with any subcontractor or permit any subcontractor to perform any work included in this contract until he has verified the subcontractor as eligible to participate in federally funded contracts.
- (b) No proposed subcontractor shall be disapproved by the city/county except for cause.
- (c) The Contractor shall be as fully responsible to the city/county for the acts and omissions of his subcontractors, and of persons either directly or indirectly employed by them.
- (d) The Contractor shall cause appropriate provisions to be inserted in all subcontracts relative to the work and required compliance by each subcontractor with the applicable provisions of the Contract.
- (e) Nothing contained in the Contract shall create any contractual relation between any subcontractor and the Owner.

5. Fitting and Coordination of Work

The Contractor shall be responsible for the proper fitting of all work and for the coordination of the operations of all trades, subcontractors, or material suppliers engaged upon this Contract.

6. Payments to Contractor

- (a) **Partial Payments**
 - 1) The Contractor shall prepare his requisition for partial payment as of the last day of the month and submit it, with the required number of copies, to the Architect for his approval. The amount of the payment due the Contractor shall be determined by adding to the total value of work completed to date, the value of materials properly stored on the site and deducting (1) Five percent (5%) of the total amount, to be retained until final payment and (2) the amount of all previous payments. The total value of work completed to date shall be based on the estimated quantities of work completed and on the unit prices contained in the agreement. The value of materials properly stored on the site shall be based upon the estimated quantities of such materials and the invoice prices. Copies of all invoices shall be available for inspection of the Architect.
 - 2) Monthly or partial payments made by the Owner to the Contractor are moneys advanced for the purpose of assisting the contractor to expedite the work of construction. The Contractor shall be responsible for the care and protection of all materials and work upon which payments have been made until final acceptance of such work and materials by the Owner. Such payments shall not

SPECIAL PROVISIONS

REQUEST FOR PROPOSAL MENTAL HEALTH COURT PUBLIC DEFENDER'S OFFICE BUILDOUT GALVESTON COUNTY, TEXAS

constitute a waiver of the right of the Owner to require the fulfillment of all terms of the Contract and the delivery of all improvements embraced in this Contract complete and satisfactory to the Owner in all details.

- (b) Final Payment
- 1) After final inspection and acceptance by the Owner of all work under the Contract, the Contractor shall prepare his requisition for final payment which shall be based upon the careful inspection of each item of work at the applicable unit prices stipulated in the Agreement. The total amount of the final payment due the Contractor under this contract shall be the amount computed as described above less all previous payments.
 - 2) The Owner before paying the final estimate, shall require the Contractor to furnish releases or receipts from all subcontractors having performed any work and all persons having supplied materials, equipment (installed on the Project) and services to the Contractor, if the Owner deems it necessary in order to protect its interest. The Owner may, if it deems such action advisable, make payment in part or in full to the Contractor without requiring the furnishing of such releases or receipts and any payments made shall in no way impair the obligations of any surety or sureties furnished under this Contract.
 - 3) Any amount due the Owner under Liquidated Damages shall be deducted from the final payment due the contractor.

- (c) Payments Subject to Submission of Certificates

Each payment to the Contractor by the Owner shall be made subject to submission by the Contractor of all written certifications required of him and his subcontractors.

- (d) Withholding Payments

The Owner may withhold from any payment due the Contractor whatever is deemed necessary to protect the Owner, and if so elects, may also withhold any amounts due from the Contractor to any subcontractors or material dealers, for work performed or material furnished by them. The foregoing provisions shall be construed solely for the benefit of the Owner and will not require the Owner to determine or adjust any claims or disputes between the Contractor and his subcontractors or material dealers, or to withhold any moneys for their protection unless the Owner elects to do so. The failure or refusal of the Owner to withhold any moneys from the Contractor shall in no way impair the obligations of any surety or sureties under any bond or bonds furnished under this Contract.

7. Changes in the Work

- (a) The Owner may make changes in the scope of work required to be performed by the Contractor under the Contract without relieving or releasing the Contractor from any of his obligations under the Contract or any guarantee given by him pursuant to the Contract provisions, and without affecting the validity of the guaranty bonds, and without relieving or releasing the surety or sureties of said bonds. All such work shall be executed under the terms of the original Contract unless it is expressly provided otherwise.
- (b) Except for the purpose of affording protection against any emergency endangering health, life, limb or property, the Contractor shall make no change in the materials used or in the specified manner of constructing and/or installing the improvements or supply additional labor, services or materials beyond that

SPECIAL PROVISIONS

REQUEST FOR PROPOSAL MENTAL HEALTH COURT PUBLIC DEFENDER'S OFFICE BUILDOUT GALVESTON COUNTY, TEXAS

actually required for the execution of the Contract, unless in pursuance of a written order from the Owner authorizing the Contractor to proceed with the change. No claim for an adjustment of the Contract Price will be valid unless so ordered.

- (c) If applicable unit prices are contained in the Agreement, the Owner may order the Contractor to proceed with desired unit prices specified in the Contract; provided that in case of a unit price contract the net value of all changes does not increase the original total amount of the agreement by more than twenty-five percent (25%) or decrease the original the total amount by eighteen percent (18%).
- (d) Each change order shall include in its final form:
 - 1) A detailed description of the change in the work.
 - 2) The Contractor's proposal (if any) or a confirmed copy thereof.
 - 3) A definite statement as to the resulting change in the contract price and/or time.
 - 4) The statement that all work involved in the change shall be performed in accordance with contract requirements except as modified by the change order.
 - 5) The procedures as outlined in this Section for a unit price contract also apply in any lump sum contract.

8. Estimated Quantities

This Contract, including the specifications, plans and estimates, is intended to show clearly all the work to be done and material to be furnished hereunder. The estimated quantities of the various classes of work to be done and material to be furnished under this contract are approximate and are to be used as a basis for estimating the probable cost of the work and for comparing the proposals offered for the work. It is understood and agreed that the actual amount of work to be done and material to be furnished under this contract may differ somewhat from these estimates, and that the basis for payment under this contract shall be the plan quantity or actual amount of such work done whichever is specified. It is further understood that the County does not guarantee any minimum amount of work under this Contract.

Contractor agrees that it will make no claim for damages, anticipated profits or otherwise on account of any differences which may be found between the quantities of work actually done, the material actually furnished under this Contract and the estimated quantities contemplated and contained in the proposals.

9. Claims for Extra Cost

- (a) If the Contractor claims that any instructions by Drawings or otherwise involve extra cost or extension of time, he shall, within ten days after the receipt of such instructions, and in any event before proceeding to execute the work, submit his protest thereto in writing to the Owner, stating clearly and in detail the basis of his objections. No such claim will be considered unless so made.
- (b) Claims for additional compensation for extra work, due to alleged errors in ground elevations, contour lines, or bench marks, will not be recognized unless accompanied by certified survey data, made prior to the time the original ground was disturbed, clearly showing that errors exist which resulted, or would result, in

SPECIAL PROVISIONS

REQUEST FOR PROPOSAL MENTAL HEALTH COURT PUBLIC DEFENDER'S OFFICE BUILDOUT GALVESTON COUNTY, TEXAS

handling more material, or performing more work, than would be reasonably estimated from the Drawings and maps issued.

- (c) Any discrepancies which may be discovered between actual conditions and those represented by the Drawings and maps shall be reported at once to the Owner and work shall not proceed except at the Contractor's risk, until written instructions have been received by him from the Owner.
- (d) If, on the basis of the available evidence, the Owner determines that an adjustment of the Contract Price and/or time is justifiable, a change order shall be executed.

10. Time

The Contractor is advised that time for completion will consist of the number of calendar days set out in the Contract Award. The time for completion will begin to run on the day after the issuance of a notice to proceed by the County. The Contractor is required to start work no later than ten (10) working days after the issuance of the written notice to proceed. Failure to timely commence operations may be deemed by the County to be a default. The Contractor will complete the work at that site within the time period specified. If there is more than one site listed on the notice to proceed, work for all sites must be completed not later than is specified for each site.

11. Termination, Delays, and Liquidated Damages

- (a) Right of the Owner to Terminate Contract.

In the event that any of the provisions of this contract are violated by the Contractor, or by any of his subcontractors, the Owner may serve written notice upon the Contractor and the Surety of its intention to terminate the contract.

The notices shall contain the reasons for such intention to terminate the contract, and unless such violation or delay shall cease and satisfactory arrangement of correction be made within ten days, the contract shall, upon the expiration of said ten (10) days, cease and terminate. In the event of any such termination, the Owner shall immediately serve notice thereof upon the Surety and the Contractor. The Surety shall have the right to take over and perform the contract. Provided, however, that if the Surety does not commence performance thereof within ten (10) days from the date of the mailing to such Surety of notice of termination, the Owner may take over the work and complete the project by bid/contract or by force account at the expense of the Contractor and his Surety shall be liable to the Owner for any excess cost incurred. In such event the Owner may take possession of and utilize in completing the work, such materials, appliances, and plant as may be on the site of the work and necessary therefore.

- (b) Liquidated Damages for Delays.

Contractor agrees that time is of the essence of this contract and that for each day of a delay of a day beyond the number of working days or calendar days herein agreed upon the completion of the work herein specified and contracted for (after due allowance for such extension of time as is provided for under Extension of Time hereinabove) County may withhold permanently from Contractor's total compensation the sum of \$1,000.00 for each calendar day of delay, until the work is completed, as liquidated damages for such delay. The Contractor and his sureties shall be liable to the Owner for the amount thereof.

- (c) Excusable Delays.

SPECIAL PROVISIONS

REQUEST FOR PROPOSAL MENTAL HEALTH COURT PUBLIC DEFENDER'S OFFICE BUILDOUT GALVESTON COUNTY, TEXAS

- 1) The right of the Contractor to proceed shall not be terminated nor shall the Contractor be charged with liquidated damages for any delays in the completion of the work due to:
 - a. Any acts of the Government, including controls or restrictions upon or requisitioning of materials, equipment, tools, or labor by reason of war, national defense, or any other national emergency;
 - b. Any acts of the Owner;
 - c. Causes not reasonably foreseeable by the parties to this Contract at the time of the execution of the Contract which are beyond the control and without the fault or negligence of the Contractor, including, but not restricted to, acts of God or of the public enemy, acts of another Contractor in the performance of some other contract with the Owner, fires, floods, epidemics, quarantine, restrictions, strikes, freight embargoes, and weather of unusual severity such as hurricanes, tornadoes, cyclones and other extreme weather conditions.
- 2) Provided, however, that the Contractor promptly notifies the Owner within ten (10) days in writing of the cause of the delay. Upon receipt of such notification, the Owner shall ascertain the facts and the cause and extent of delay. If, upon the basis of the facts and the terms of this contract, the delay is properly excusable, the Owner shall extend the time for completing the work for a period of time commensurate with the period of excusable delay.

12. Assignment or Novation

The Contractor shall not assign or transfer, whether by an assignment or novation, any of its rights, duties, benefits, obligations, liabilities, or responsibilities under this Contract without the written consent of the Owner; provided, however, that assignments to banks or other financial institutions may be made without the consent of the Owner. No assignment or novation of this Contract shall be valid unless the assignment or novation expressly provides that the assignment of any of the Contractor's rights or benefits under the Contract is subject to a prior lien for labor performed, services rendered, and materials, tools, and equipment supplied for the performance of the work under this Contract in favor of all persons, firms, or corporations rendering such labor or services or supplying such materials, tools, or equipment.

13. Disputes

- (a) All disputes arising under this Contract or its interpretation except those disputes covered by FEDERAL LABOR STANDARDS PROVISIONS whether involving law or fact or both, or extra work, and all claims for alleged breach of contract shall, within ten (10) days of commencement of the dispute, be presented by the Contractor to the Owner for decision. Any claim not presented within the time limit specified in this paragraph shall be deemed to have been waived, except that if the claim is of a continuing character and notice of the claim is not given within ten (10) days of its commencement, the claim will be considered only for a period commencing ten (10) days prior to the receipt of the Owner.
- (b) The Contractor shall submit in detail his claim and his proof thereof.
- (c) If the Contractor does not agree with any decision of the Owner, he shall in no case allow the dispute to delay the work but shall notify the Owner promptly that he is proceeding with the work under protest.

SPECIAL PROVISIONS

REQUEST FOR PROPOSAL MENTAL HEALTH COURT PUBLIC DEFENDER'S OFFICE BUILDOUT GALVESTON COUNTY, TEXAS

14. Technical Specifications and Drawings

Anything mentioned in the Technical Specifications and not shown on the Drawings, or vice versa, shall be of like effect as if shown on or mentioned in both. In case of difference between Drawings and Technical Specifications, the Technical Specifications shall govern. In case of any discrepancy in Drawings, or Technical Specifications, the matter shall be immediately submitted to the Owner, without whose decision, said discrepancy shall not be adjusted by the Contractor, save only at his own risk and expense.

15. Shop Drawings

- (a) All required shop drawings, machinery details, layout drawings, etc. shall be submitted to the Architect in copies for approval sufficiently in advance of requirements to afford ample time for checking, including time for correcting, resubmitting and rechecking if necessary. The Contractor may proceed, only at his own risk, with manufacture or installation of any equipment or work covered by said shop drawings, etc. until they are approved and no claim, by the Contractor, for extension of the contract time shall be granted by reason of his failure in this respect.
- (b) Any drawings submitted without the Contractor's stamp of approval will not be considered and will be returned to him for proper resubmission. If any drawings show variations from the requirements of the Contract because of standard shop practice or other reason, the Contractor shall make specific mention of such variation in his letter of transmittal in order that, if acceptable, suitable action may be taken for proper adjustment of contract price and/or time, otherwise the Contractor will not be relieved of the responsibility for executing the work in accordance with the Contract even though the drawings have been approved.
- (c) If a shop drawing is in accordance with the contract or involves only a minor adjustment in the interest of the owner not involving a change in contract price or time; the Architect may approve the drawing. The approval shall not relieve the Contractor from his responsibility for adherence to the contract or for any error in the drawing.

16. Requests for Supplementary Information

It shall be the responsibility of the Contractor to make timely requests of the Owner for any additional information not already in his possession which should be furnished by the Owner under the terms of this Contract, and which he will require in the planning and execution of the work. Such requests may be submitted from time to time as the need approaches, but each shall be filed in ample time to permit appropriate action to be taken by all parties involved so as to avoid delay. Each request shall be in writing and list the various items and the latest date by which each will be required by the Contractor. The first list shall be submitted within two weeks after Contract award and shall be as complete as possible at that time. The Contractor shall, if requested, furnish promptly any assistance and information the Architect may require in responding to these requests of the Contractor. The Contractor shall be fully responsible for any delay in his work or to others arising from his failure to comply fully with the provision of this section.

SPECIAL PROVISIONS

REQUEST FOR PROPOSAL MENTAL HEALTH COURT PUBLIC DEFENDER'S OFFICE BUILDOUT GALVESTON COUNTY, TEXAS

17. Materials and Workmanship

- (a) Unless otherwise specifically provided for in the technical specifications, all workmanship, equipment, materials and articles incorporated in the work shall be new and the best grade of the respective kinds for the purpose. Where equipment, materials, articles or workmanship are referred to in the technical specifications as "equal to" any particular standard, the Architect shall decide the question of equality.
- (b) The Contractor shall furnish to the Owner for approval the manufacturer's detailed specifications for all machinery, mechanical and other special equipment, which he contemplates installing together with full information as to type, performance characteristics, and all other pertinent information as required, and shall likewise submit for approval full information concerning all other materials or articles which he proposes to incorporate.
- (c) Machinery, mechanical and other equipment, materials or articles installed or used without such prior approval shall be at the risk of subsequent rejection.
- (d) Materials specified by reference to the number or symbol of a specific standard, shall comply with requirements in the latest revision thereof and any amendment or supplement thereto in effect on the date of the Invitation for Bids, except as limited to type, class or grade, or modified in the technical specifications shall have full force and effect as though printed therein.
- (e) The Owner may require the Contractor to dismiss from the work such employee or employees as the Owner or the Architect may deem incompetent, or careless, or insubordinate.

18. Samples, Certificates and Tests

- (a) The Contractor shall submit all material or equipment samples, certificates, affidavits, etc., as called for in the contract documents or required by the Architect, promptly after award of the contract and acceptance of the Contractor's bond. No such material or equipment shall be manufactured or delivered to the site, except at the Contractor's own risk, until the required samples or certificates have been approved in writing by the Architect. Any delay in the work caused by late or improper submission of samples or certificates for approval shall not be considered just cause for an extension of the contract time.
- (b) Each sample submitted by the Contractor shall carry a label giving the name of the Contractor, the project for which it is intended, and the name of the producer. The accompanying certificate or letter from the Contractor shall state that the sample complies with contract requirements, shall give the name and brand of the product, its place of origin, the name and address of the producer and all specifications or other detailed information which will assist the Architect in making a prompt decision regarding the acceptability of the sample. It shall also include the statement that all materials or equipment furnished for use in the project will comply with the samples and/or certified statements.
- (c) Approval of any materials shall be general only and shall not constitute a waiver of the Owner's right to demand full compliance with Contract requirements. After actual deliveries, the Architect will have such check tests made as he deems necessary in each instance and may reject materials and equipment and accessories for cause, even though such materials and articles have been given general approval. If materials, equipment or accessories which fail to meet check tests have been incorporated in the work, the Architect will have the right to cause their removal and replacement by proper materials or to demand and secure such reparation by the Contractor as is equitable.

SPECIAL PROVISIONS

REQUEST FOR PROPOSAL MENTAL HEALTH COURT PUBLIC DEFENDER'S OFFICE BUILDOUT GALVESTON COUNTY, TEXAS

- (d) Except as otherwise specifically stated in the Contract, the costs of sampling and testing will be divided as follows:
- 1) The Contractor shall furnish without extra cost, including packing and delivery charges, all samples required for testing purposes, except those samples taken on the project by the Architect;
 - 2) The Contractor shall assume all costs of re-testing materials which fail to meet contract requirements;
 - 3) The Contractor shall assume all costs of testing materials offered in substitution for those found deficient;
 - 4) The Owner will pay all other expenses.

19. Permits and Codes

- (a) The Contractor shall give all notices required by and comply with all applicable laws, ordinances, and codes of the Local Government. All construction work and/or utility installations shall comply with all applicable ordinances, and codes including all written waivers. Before installing any work, the Contractor shall examine the drawings and technical specifications for compliance with applicable ordinances and codes and shall immediately report any discrepancy to the Owner. Where the requirements of the drawings and technical specifications fail to comply with such applicable ordinances or codes, the Owner will adjust the Contract by Change Order to conform to such ordinances or codes (unless waivers in writing covering the difference have been granted by the governing body or department) and make appropriate adjustment in the Contract Price or stipulated unit prices.
- (b) Should the Contractor fail to observe the foregoing provisions and proceed with the construction and/or install any utility at variance with any applicable ordinance or code, including any written waivers (notwithstanding the fact that such installation is in compliance with the drawings and technical specifications), the Contractor shall remove such work without cost to the Owner.
- (c) The Contractor shall at his own expense, secure and pay for all permits for street pavement, sidewalks, shed, removal of abandoned water taps, sealing of house connection drains, pavement cuts, buildings, electrical, plumbing, water, gas and sewer permits required by the local regulatory body or any of its agencies.
- (d) The Contractor shall comply with applicable local laws and ordinances governing the disposal of surplus excavation, materials, debris and rubbish on or off the Project Area and commit no trespass on any public or private property in any operation due to or connected with the Improvements contained in this Contract.
- (e) The Contractor will be required to make arrangements for and pay the water, electrical power, or any other utilities required during construction.
- (f) During construction of this project, the Contractor shall use every means possible to control the amount of dust created by construction. Prior to the close of a day's work, the Contractor, if directed by the Owner, shall moisten the bank and surrounding area to prevent a dusty condition.

SPECIAL PROVISIONS

REQUEST FOR PROPOSAL MENTAL HEALTH COURT PUBLIC DEFENDER'S OFFICE BUILDOUT GALVESTON COUNTY, TEXAS

20. Care of Work

- (a) The Contractor shall be responsible for all damages to person or property that occur as a result of his fault or negligence in connection with the prosecution of the work and shall be responsible for the proper care and protection of all materials delivered and work performed until completion and final acceptance.
- (b) The Contractor shall provide sufficient competent watchmen, both day and night, including Saturdays, Sundays, and holidays, from the time the work is commenced until final completion and acceptance.
- (c) In an emergency affecting the safety of life, limb or property, including adjoining property, the Contractor, without special instructions or authorization from the Owner is authorized to act at his discretion to prevent such threatened loss or injury, and he shall so act. He shall likewise act if instructed to do so by the Owner.
- (d) The Contractor shall avoid damage as a result of his operations to existing sidewalks, streets, curbs, pavements, utilities (except those which are to be replaced or removed), adjoining property, etc., and he shall at his own expense completely repair any damage thereto caused by his operations.
- (e) The Contractor shall shore up, brace, underpin, secure, and protect as maybe necessary, all foundations and other parts of existing structures adjacent to, adjoining, and in the vicinity of the site, which may be in any way affected by the excavations or other operations connected with the construction of the improvements included in this Contract. The Contractor shall be responsible for the giving of any and all required notices to any adjoining or adjacent property owner or other party before the commencement of any work. The Contractor shall indemnify and save harmless the Owner from any damages on account of settlements or the loss of lateral support of adjoining property and from all loss or expense and all damages for which the Owner may become liable in consequence of such injury or damage to adjoining and adjacent structures and their premises.

21. Accident Prevention

- (a) No laborer or mechanic employed in the performance of this Contract shall be required to work in surroundings or under working conditions which are unsanitary, hazardous, or dangerous to his health or safety as determined under construction safety and health standards promulgated by the Secretary of Labor.
- (b) The Contractor shall exercise proper precaution at all times for the protection of persons and property and shall be responsible for all damages to persons or property, either on or off the site, which occur as a result of his prosecution of the work.
- (c) The Contractor shall maintain an accurate record of all cases of death, occupational disease, or injury requiring medical attention or causing loss of time from work, arising out of and in the course of employment on work under the Contract. The Contractor shall promptly furnish the Owner with reports concerning these matters.
- (d) The Contractor shall indemnify and save harmless the Owner from any claims for damages resulting from property damage, personal injury and/or death suffered or alleged to have been suffered by any person as a result of any work conducted under this contract.
- (e) The Contractor shall provide trench safety for all excavations more than five feet deep prior to excavation. All OSHA Standards for trench safety must be adhered to by the Contractor.

SPECIAL PROVISIONS

REQUEST FOR PROPOSAL MENTAL HEALTH COURT PUBLIC DEFENDER'S OFFICE BUILDOUT GALVESTON COUNTY, TEXAS

- (f) The contractor shall at all times conduct his work in such a manner as to insure the least possible inconvenience to vehicular and pedestrian traffic. At the close of the work each day, all streets where possible in the opinion of the Owner, shall be opened to the public in order that persons living in the area may have access to their homes or businesses by the use of the streets. Barricades, warning signs, and necessary lighting shall be provided to the satisfaction of the Owner at the expense of the Contractor.

22. Sanitary Facilities

The Contractor shall furnish, install and maintain ample sanitary facilities for the workmen. As the needs arise, a sufficient number of enclosed temporary toilets shall be conveniently placed as required. Drinking water shall be provided from an approved source, so piped or transported as to keep it safe and fresh and served from single service containers or satisfactory types of sanitary drinking stands or fountains. All such facilities and services shall be furnished in strict accordance with existing and governing health regulations.

23. Use of Premises

- (a) The Contractor shall confine his equipment, storage of materials, and construction operations to the contract limits as shown on the drawings and as prescribed by ordinances or permits, or as may be desired by the Owner, and shall not unreasonably encumber the site or public rights of way with his materials and construction equipment.
- (b) The Contractor shall comply with all reasonable instructions of the Owner and all existing state and local regulations regarding signs, advertising, traffic, fires, explosives, danger signals, and barricades.

24. Removal of Debris, Cleaning, Etc.

The Contractor shall, periodically or as directed during the progress of the work, remove and legally dispose of all surplus excavated material and debris, and keep the Project Area and public rights of way reasonably clear. Upon completion of the work, he shall remove all temporary construction facilities, debris and unused materials provided for work, and put the whole site of the work and public rights of way in a neat and clean condition.

25. Inspection

- (a) All materials and workmanship shall be subject to inspection, examination, or test by the Owner and Architect at any and all times during manufacture or construction and at any and all places where such manufacture or construction occurs. The Owner shall have the right to reject defective material and workmanship or require its correction. Unacceptable workmanship shall be satisfactorily corrected. Rejected material shall be promptly segregated and removed from the Project Area and replaced with material of specified quality without charge. If the Contractor fails to proceed at once with the correction of rejected workmanship or defective material, the Owner may by contract or otherwise have the defects remedied or rejected materials removed from the Project Area and charge the cost of the same against any Monies which may be due the Contractor, without prejudice to any other rights or remedies of the Owner.
- (b) The Contractor shall furnish promptly all materials reasonably necessary for any tests which may be required. All tests by the Owner will be performed in such manner as not to delay the work unnecessarily and will be made in accordance with the provisions of the technical specifications.

SPECIAL PROVISIONS

REQUEST FOR PROPOSAL MENTAL HEALTH COURT PUBLIC DEFENDER'S OFFICE BUILDOUT GALVESTON COUNTY, TEXAS

- (c) The Contractor shall notify the Owner sufficiently in advance of back filling or concealing any facilities to permit proper inspection. If any facilities are concealed without approval or consent of the Owner, the Contractor shall uncover for inspection and recover such facilities at his own expense, when so requested by the Owner.
- (d) Should it be considered necessary or advisable by the Owner at any time before final acceptance of the entire work to make an examination of work already completed by uncovering the same, the Contractor shall on request promptly furnish all necessary facilities, labor, and material. If such work is found to be defective in any important or essential respect, due to fault of the Contractor or his subcontractors, the Contractor shall defray all the expenses of such examination and of satisfactory reconstruction. If, however, such work is found to meet the requirements of the Contract, the actual cost of labor and material necessarily involved in the examination and replacement, shall be allowed the Contractor and he shall, in addition, if completion of the work of the entire Contract has been delayed thereby, be granted a suitable extension of time on account of the additional work involved.
- (e) Inspection of materials and appurtenances to be incorporated in the improvements included in this Contract may be made at the place of production, manufacture or shipment, whenever the quantity justifies it, and such inspection and acceptance, unless otherwise stated in the technical specifications, shall be final, except as regards (1) latent defects, (2) departures from specific requirements of the Contract, (3) damage or loss in transit, or (4) fraud or such gross mistakes as amount to fraud. Subject to the requirements contained in the preceding sentence, the inspection of materials as a whole or in part will be made at the Project Site.
- (f) Neither inspection, testing, approval nor acceptance of the work in whole or in part, by the Owner or its agents shall relieve the Contractor or his sureties of full responsibility for materials furnished or work performed not in strict accordance with the Contract.

26. Review by Owner

The Owner and its authorized representatives and agents shall have access to and be permitted to observe and review all work, materials, equipment, payrolls, personnel records, employment conditions, material invoices, and other relevant data and records pertaining to this Contract, provided, however that all instructions and approval with respect to the work will be given to the Contractor only by the Owner through its authorized representatives or agents.

27. Final Inspection

When the Improvements included in this Contract are substantially completed, the Contractor shall notify the Owner in writing that the work will be ready for final inspection on a definite date which shall be stated in the notice. The Owner will make the arrangements necessary to have final inspection commenced on the date stated in the notice, or as soon thereafter as is practicable.

28. Deduction for Uncorrected Work

If the Owner deems it not expedient to require the Contractor to correct work not done in accordance with the Contract Documents, an equitable deduction from the Contract Price will be made by agreement between the Contractor and the Owner and subject to settlement, in case of dispute, as herein provided.

SPECIAL PROVISIONS

REQUEST FOR PROPOSAL MENTAL HEALTH COURT PUBLIC DEFENDER'S OFFICE BUILDOUT GALVESTON COUNTY, TEXAS

29. Warranty of Title

No material, supplies, or equipment to be installed or furnished under this Contract shall be purchased subject to any chattel mortgage or under a conditional sale, lease-purchase or other agreement by which an interest is retained by the seller or supplier. The Contractor shall warrant good title to all materials, supplies, and equipment installed or incorporated in the work and upon completion of all work, shall deliver the same together with all improvements and appurtenances constructed or placed by him to the Owner free from any claims, liens, or charges. Neither the Contractor nor any person, firm, or corporation furnishing any material or labor for any work covered by this Contract shall have any right to a lien upon any improvement or appurtenance. Nothing contained in this paragraph, however, shall defeat or impair the right of persons furnishing materials or labor to recover under any law permitting such persons to look to funds due the Contractor in the hands of the Owner. The provisions of this paragraph shall be inserted in all subcontracts and material contracts and notice of its provisions shall be given to all persons furnishing materials for the work when no formal contract is entered into for such materials.

30. Warranty of Workmanship and Materials

Neither the final certificate of payment nor any provision in the Contract nor partial or entire use of the improvements included in this Contract by the Owner or the public shall constitute an acceptance of work not done in accordance with the Contract or relieve the Contractor of liability in respect to any express warranties or responsibility for faulty materials or workmanship. The Contractor shall promptly remedy any defects in the work and pay for any damage to other work resulting therefrom which shall appear within a period of 12 months from the date of final acceptance of the work.

31. Job Offices

- (a) The Contractor and his subcontractors may maintain such office and storage facilities on the site as are necessary for the proper conduct of the work. These shall be located so as to cause no interference to any work to be performed on the site. The Owner shall be consulted with regard to locations.
- (b) Upon completion of the improvements, or as directed by the Owner, the Contractors shall remove all such temporary structures and facilities from the site and leave the site of the work in the condition required by the contract.

32. Partial Use of Site Improvements

The Owner may give notice to the Contractor and place in use those sections of the improvements which have been completed, inspected and can be accepted as complying with the technical specifications and if in its opinion, each such section is reasonably safe, fit, and convenient for the use and accommodation for which it was intended, provided:

- (a) The use of such sections of the Improvements shall in no way impede the completion of the remainder of the work by the Contractor.
- (b) The Contractor shall not be responsible for any damages or maintenance costs due directly to the use of such sections.
- (c) The period of guarantee stipulated in the Section 29 hereof shall not begin to run until the date of the final acceptance of all work which the Contractor is required to construct under this Contract.

SPECIAL PROVISIONS

REQUEST FOR PROPOSAL MENTAL HEALTH COURT PUBLIC DEFENDER'S OFFICE BUILDOUT GALVESTON COUNTY, TEXAS

33. Contract Period

The work to be performed under this contract shall commence within the time stipulated by the Owner in the Notice to Proceed and shall be fully completed within 180 calendar days thereafter.

34. Keeping of Plans and Specifications Accessible

The Contractor shall keep one (1) copy of all Plans and Specifications constantly accessible at the work site and available for inspection at all times.

35. Utilities

Contractor shall be responsible for any charges which may be made by any city or utility companies for the work to be performed by Contractor.

36. Parking

Contractor shall be responsible for the expense of parking the Contractor's vehicle(s) in a legal manner and at no expense or inconvenience to the County.

37. Fire and Safety

Contractor is completely responsible for fire protection at the job site as well as the safety of its own employees as well as those entering onto the job site.

38. Contractor's Buildings

The building of structures for housing men, or the erection of tents or other forms of protection will be permitted only at such places as the County shall permit, and the sanitary conditions of the grounds in or about such structures shall at all times be maintained in the manner satisfactory to the County.

39. Worksite Security

Contractor shall maintain the security of the worksite.

Contractor shall provide adequate protection to persons on the worksite, adjacent properties, and utilities as is necessary to keep each free of damage or injury. Contractor shall furnish all barricades, warning lights and other safety devices necessary for the safety and protection of the public and shall remove them upon completion of the work performed on those premises under the terms of this contract.

Contractor will have complete control over the work site and shall be fully responsible for any loss of or damage to any County property from any cause and will reimburse County in the event of any loss or damage to County's property from any cause.

Contractor shall take proper means to protect adjacent or adjoining properties which might be injured or seriously affected by construction undertaken under this Agreement from any damage or injury by reason of said process of

SPECIAL PROVISIONS

REQUEST FOR PROPOSAL MENTAL HEALTH COURT PUBLIC DEFENDER'S OFFICE BUILDOUT GALVESTON COUNTY, TEXAS

construction. Contractor shall be liable for any and all claims for such damage on account of its failure to fully protect all adjoining properties.

40. Final Grading

If grading is required, when work is complete, Contractor shall grade the site to fill in holes and make a presentable appearance without disturbing trees and add fill dirt if needed. Contractor may not leave voids in the grading and compaction of the property. The land shall have a smooth appearance without concrete, bricks, building materials, and other debris on the surface.

41. Changes and Alterations

Contractor further agrees that County may make such changes and alterations as County may see fit, in the line, grade, form dimensions, plans or materials for the work herein contemplated, or any part thereof, either before or after the beginning of the contract construction, without affecting the validity of this Contract and the accompanying bonds.

If such changes or alterations diminish the quantity of the work to be done, they shall not constitute the basis for a claim for damages, or anticipated profits on the work that may be dispensed with. If they increase the amount of the work, and the increased work can fairly be classified under the specifications, such increase shall be paid for according to the quantity actually done and at the unit price established for such work under this contract; otherwise such additional work shall be paid for as provided under the paragraph entitled "EXTRA WORK". In case the County shall make such changes or alterations as shall make useless any work already done or material already furnished or used in said work, then County shall recompense Contractor for any material or labor so used, and for any actual loss occasioned by such change due to actual expenses incurred in preparation for the work as originally planned.

42. Extra Work

The term "Extra Work" as used in this contract shall be understood to mean and include all work that may be required by the County to be done by Contractor to accomplish any change, alteration or addition to the work shown in the plans and specifications.

It is agreed that Contractor shall perform all Extra Work under the direction of the County when presented with a Written Work Order signed by the County. It is also agreed that the compensation to be paid Contractor for performing said Extra Work shall be determined by one or more of the following methods:

Method (a) - By agreed unit prices; or
Method (b) - By agreed lump sum: or

Method (c) - If Neither Method (a) nor Method (b) can be agreed upon before the Extra Work is commenced, then Contractor shall be paid the "Actual field cost" of the work plus fifteen (15) percent.

In the event said Extra Work be performed and paid for under Method (c), then the provisions of this paragraph shall apply and the "actual field cost" is hereby defined to include the cost of all workmen, such as foremen, timekeepers, merchants, and laborers, and materials, supplies, teams, trucks, rentals on machinery and equipment for time actually employed or used on such Extra Work plus actual transportation charges necessarily incurred, if the kind of equipment or machinery is not already on the job, together with all power, fuel, lubricants, water and similar operating expenses, also all necessary incidental expenses incurred directly on account of such Extra Work including Social Security, Old Age Benefits and other payroll taxes, and a ratable proportion of premiums on Construction and Maintenance Bonds,

SPECIAL PROVISIONS

REQUEST FOR PROPOSAL MENTAL HEALTH COURT PUBLIC DEFENDER'S OFFICE BUILDOUT GALVESTON COUNTY, TEXAS

Public Liability and Property Damage and Workmen's Compensation, and all other insurance as may be required by any law or ordinance. The County may direct the form in which accounts of the "actual field cost" shall be kept and may also specify in writing, before the work commences, the method of doing the work and the type and kind of machinery and equipment to be used, otherwise these matters shall be determined by Contractor. Unless otherwise agreed upon, the prices for the use of machinery and equipment shall be determined by using the one hundred (100) percent of the actual hourly or daily rate (for the time used plus time in moving to and from Job) of the latest schedule of Equipment Ownership Expense adopted by the Association General Contractors of America. Where practicable the terms and prices for the use of Machinery and Equipment shall be incorporated in the Written Extra Work Order. The fifteen (15) percent of the "Actual Field Cost" to be paid Contractor shall cover and compensate him for his profit, overhead, general superintendence and field office expense, and all other elements of cost and expense not embraced within the 'actual field cost" as herein defined, save that where the Contractor's Camp or Field Office must be maintained primarily on account of such extra work, then the cost to maintain and operate same shall be included in the "actual field cost".

No claim for extra work of any kind will be allowed unless ordered in writing by the County. In case any orders or instructions, either oral or written appear to Contractor to involve extra work for which he should receive compensation, it shall make written request to the County for written order authorizing Extra Work. Should a difference of opinion arise as to what does or does not constitute extra work, or as to the payment therefor, and the County insists upon its performance, Contractor shall proceed with the work after making written order and shall keep an accurate account of the "actual field cost" thereof, as provided under Method (c) and by this action Contractor will thereby preserve the right to submit the matter of payment to litigation.

43. Salvage

Any materials, equipment and fixtures specifically ordered to be salvaged under these specifications shall remain the property of County and will be delivered to the site designated by the County. All other items shall be disposed of by Contractor in compliance with all applicable laws and regulations.

44. Compliance with Codes

Contractor shall comply with all city, county, and state codes, laws, and ordinances in force at the time of award of contract and applicable to such work. Contractor shall obtain, at Contractor's own expense such permits, certificates, and licenses as may be required in the performance of the specified work.

45. Laws and Ordinances

Contractor shall at all times observe and comply with all Federal, State and Local Laws, ordinances and regulations which in any manner effect the contract or the work and shall indemnify and save harmless the County against any claim arising from the violation of any such laws and ordinances, whether by Contractor or its employees.

46. Permits and Licenses

Contractor shall be responsible for obtaining and furnishing all necessary permits and licenses, City, County, State or Federal as are required for the performance of this contract.

SPECIAL PROVISIONS

REQUEST FOR PROPOSAL MENTAL HEALTH COURT PUBLIC DEFENDER'S OFFICE BUILDOUT GALVESTON COUNTY, TEXAS

47. Lines and Grades

The Architect will furnish points for horizontal and vertical control. Any additional stakes required by the Contractor shall be set at his expense. Whenever necessary, work shall be suspended to permit this work, but such suspension will be as brief as practicable, and the Contractor shall be allowed no extra compensation therefor. The Contractor shall give the Architect ample notice of the time and place where control lines and benchmarks will be needed. All control stakes, marks, etc. shall be carefully preserved by the Contractor, and in case of careless destruction or removal by him or his employees, such control stakes, marks, etc. shall be replaced by the Architect at the Contractor's expense.

48. Excess, Waste Material and Debris

All excess material, waste material and debris shall become the property of the Contractor and shall be properly disposed of off-site. No separate payment shall be made for same.

49. Material Hauling

Hauling of materials will not be paid for directly, however, shall be considered as subsidiary work pertaining to the respective bid items. Haul routes for full and empty loads shall be restricted to State Highways. Hauling of equipment is also restricted to State Highways.

50. Abatement and Mitigation of Excessive or Unnecessary Construction Noise

Throughout all phases of the construction of this project, including the moving, unloading, operating and handling of construction equipment prior to commencement of work, during the project and after the work is complete, the contractor shall make every reasonable effort to minimize the noise imposed upon the immediate neighborhood surrounding the area of construction. Particular and special efforts shall be exercised by the Contractor to avoid the creation of unnecessary noise impacts on adjacent sensitive receptors in the placement of non-mobile equipment such as air compressors, generators, pumps, etc. The placement of temporary parked mobile equipment with the engine running shall be such as to cause the least disruption of normal adjacent activities not associated with the work to be performed by the contractor.

All equipment associated with the work shall be equipped with components designed by the manufacturer wholly or in part to suppress excessive noise and these components shall be maintained in their original operating condition considering normal depreciation. Noise-attenuation devices installed by the manufacturer such as mufflers, engine covers, insulation, etc., shall not be removed nor rendered ineffectual nor be permitted to remain off the equipment while the equipment is in use.

51. Working Hours

Work shall not be commenced by the contractor before sunrise and shall be so conducted that all equipment is off the road and safely stored by sunset. Specific permission shall be obtained by the contractor from the Architect for work during those hours between 7:00 P.M. and 6:00 A.M. of the following day.

SPECIAL PROVISIONS

REQUEST FOR PROPOSAL MENTAL HEALTH COURT PUBLIC DEFENDER'S OFFICE BUILDOUT GALVESTON COUNTY, TEXAS

52. Pipeline, Utility Locations and Contractor Responsibility

An effort to determine all pipelines and utilities which may impact the project has been made. All known pipelines and utilities have been approximately located and shown on the plans. The Contractor shall notify all utility and pipeline owners before beginning the work. Additional unknown utilities and pipelines may be found. Adjustments of these utilities or pipelines shall be done by others at no expense to the contractor. However, the Contractor shall cooperate and coordinate his work with the adjustment

The Contractor will anticipate this in making his bid. The contractor will not be allowed claims for damages or delays for these adjustments should they be necessary. However, additional time will be considered for the contract period.

This action, however, shall in no way be interpreted as relieving the Contractor of his responsibilities under the terms of the contract as set out in the plans and specifications. The Contractor shall repair any damage to the facilities caused by his operations at the Contractor's expense and shall restore facilities to service in a timely manner.

53. Incidentals

All items of work required under this contract not specifically called for in the proposal as pay items shall be considered incidental to the various bid items and no separate payment shall be made for same.

54. Flagmen

During certain phases of construction flagmen will be required to direct and control traffic. This work will not be paid for directly, however, shall be considered incidental the various bid items and no separate payment shall be made for same.

55. Field Office

For this project the Contractor will not have to provide a field office.

56. Wage Rates:

The attached schedule of wages per hour for this Contract follows.

Insert Prevailing Wage Rates Here

"General Decision Number: TX20210248 07/09/2021

Superseded General Decision Number: TX20200248

State: Texas

Construction Type: Building

County: Galveston County in Texas.

BUILDING CONSTRUCTION PROJECTS (does not include single family homes or apartments up to and including 4 stories).

Note: Under Executive Order (EO) 13658, an hourly minimum wage of \$10.95 for calendar year 2021 applies to all contracts subject to the Davis-Bacon Act for which the contract is awarded (and any solicitation was issued) on or after January 1, 2015. If this contract is covered by the EO, the contractor must pay all workers in any classification listed on this wage determination at least \$10.95 per hour (or the applicable wage rate listed on this wage determination, if it is higher) for all hours spent performing on the contract in calendar year 2021. If this contract is covered by the EO and a classification considered necessary for performance of work on the contract does not appear on this wage determination, the contractor must pay workers in that classification at least the wage rate determined through the conformance process set forth in 29 CFR 5.5(a)(1)(ii) (or the EO minimum wage rate, if it is higher than the conformed wage rate). The EO minimum wage rate will be adjusted annually. Please note that this EO applies to the above-mentioned types of contracts entered into by the federal government that are subject to the Davis-Bacon Act itself, but it does not apply to contracts subject only to the Davis-Bacon Related Acts, including those set forth at 29 CFR 5.1(a)(2)-(60). Additional information on contractor requirements and worker protections under the EO is available at www.dol.gov/whd/govcontracts.

Modification Number	Publication Date
0	01/01/2021
1	03/12/2021
2	07/09/2021

ASBE0022-009 06/01/2019

	Rates	Fringes
ASBESTOS WORKER/HEAT & FROST INSULATOR (Duct, Pipe and Mechanical System Insulation)....	\$ 24.28	14.16

BOIL0074-003 01/01/2017

	Rates	Fringes
BOILERMAKER.....	\$ 28.00	22.35

CARP0551-011 04/01/2016

	Rates	Fringes
CARPENTER (Excludes Acoustical Ceiling		

Installation, Drywall
 Finishing/Taping, Drywall
 Hanging, Form Work and Metal
 Stud Installation).....\$ 23.05 8.78

 ELEC0527-002 10/28/2019

Rates Fringes

ELECTRICIAN (Excludes Low
 Voltage Wiring and
 Installation of Alarms).....\$ 29.43 3% + 10.65

 ELEV0031-003 01/01/2021

Rates Fringes

ELEVATOR MECHANIC.....\$ 45.48 36.365

FOOTNOTES:

A. 6% under 5 years based on regular hourly rate for all
 hours worked. 8% over 5 years based on regular hourly rate
 for all hours worked.

B. Holidays: New Year's Day; Memorial Day; Independence Day;
 Labor Day; Thanksgiving Day; Friday after Thanksgiving Day;
 Christmas Day; and Veterans Day.

 ENGI0450-002 04/01/2014

Rates Fringes

POWER EQUIPMENT OPERATOR
 Cranes.....\$ 34.85 9.85

 IRON0084-011 06/01/2020

Rates Fringes

IRONWORKER, ORNAMENTAL.....\$ 25.26 7.13

 PAIN0130-002 06/01/2018

Rates Fringes

PAINTER (Brush, Roller, and
 Drywall Finishing/Taping).....\$ 17.88 9.50

 PLAS0079-004 01/01/2015

Rates Fringes

PLASTERER.....\$ 19.92 1.00

 PLUM0068-002 10/01/2020

Rates Fringes

PLUMBER.....\$ 36.15 11.88

 * PLUM0211-010 04/01/2021

Rates Fringes

PIPEFITTER (Including HVAC
Pipe Installation).....\$ 35.68 12.46

SHEE0054-012 04/01/2020

Rates Fringes

SHEET METAL WORKER
Excludes HVAC Duct and
Unit Installation.....\$ 29.70 13.85
HVAC Duct Installation Only.\$ 29.70 13.85

SUTX2014-024 07/21/2014

Rates Fringes

ACOUSTICAL CEILING MECHANIC.....\$ 16.41 3.98
BRICKLAYER.....\$ 19.86 0.00
CAULKER.....\$ 15.36 0.00
CEMENT MASON/CONCRETE FINISHER...\$ 13.82 0.00
DRYWALL HANGER AND METAL STUD
INSTALLER.....\$ 17.88 5.24
ELECTRICIAN (Alarm
Installation Only).....\$ 17.97 3.37
ELECTRICIAN (Low Voltage
Wiring Only).....\$ 19.23 3.55
FLOOR LAYER: Carpet.....\$ 20.00 0.00
FORM WORKER.....\$ 12.07 0.00
GLAZIER.....\$ 17.09 3.41
HVAC MECHANIC (Installation
of HVAC Unit Only).....\$ 17.40 0.00
IRONWORKER, REINFORCING.....\$ 12.10 0.00
IRONWORKER, STRUCTURAL.....\$ 25.37 6.00
LABORER: Common or General.....\$ 11.47 0.00
LABORER: Mason Tender - Brick...\$ 13.37 0.00
LABORER: Mason Tender -
Cement/Concrete.....\$ 10.50 0.00
LABORER: Pipelayer.....\$ 12.94 0.00
LABORER: Roof Tearoff.....\$ 11.28 0.00
LABORER: Landscape and
Irrigation.....\$ 9.49 0.00
LATHER.....\$ 20.11 0.00
OPERATOR:
Backhoe/Excavator/Trackhoe.....\$ 14.10 0.00

OPERATOR: Bobcat/Skid Steer/Skid Loader.....	\$ 13.93	0.00
OPERATOR: Bulldozer.....	\$ 20.77	0.00
OPERATOR: Drill.....	\$ 16.22	0.34
OPERATOR: Forklift.....	\$ 15.64	0.00
OPERATOR: Grader/Blade.....	\$ 13.37	0.00
OPERATOR: Loader.....	\$ 13.55	0.94
OPERATOR: Mechanic.....	\$ 17.52	3.33
OPERATOR: Paver (Asphalt, Aggregate, and Concrete).....	\$ 16.03	0.00
OPERATOR: Roller.....	\$ 16.00	0.00
PAINTER: Spray (Excludes Drywall Finishing/Taping).....	\$ 17.43	4.43
ROOFER.....	\$ 15.40	0.00
SPRINKLER FITTER (Fire Sprinklers).....	\$ 18.62	3.03
TILE FINISHER.....	\$ 12.00	0.00
TILE SETTER.....	\$ 16.17	0.00
TRUCK DRIVER: 1/Single Axle Truck.....	\$ 14.95	5.23
TRUCK DRIVER: Dump Truck.....	\$ 12.39	1.18
TRUCK DRIVER: Flatbed Truck.....	\$ 19.65	8.57
TRUCK DRIVER: Semi-Trailer Truck.....	\$ 12.50	0.00
TRUCK DRIVER: Water Truck.....	\$ 12.00	4.11
WATERPROOFER.....	\$ 14.39	0.00

WELDERS - Receive rate prescribed for craft performing operation to which welding is incidental.

=====
Note: Executive Order (EO) 13706, Establishing Paid Sick Leave for Federal Contractors applies to all contracts subject to the Davis-Bacon Act for which the contract is awarded (and any solicitation was issued) on or after January 1, 2017. If this contract is covered by the EO, the contractor must provide employees with 1 hour of paid sick leave for every 30 hours they work, up to 56 hours of paid sick leave each year. Employees must be permitted to use paid sick leave for their own illness, injury or other health-related needs, including preventive care; to assist a family member (or person who is like family to the employee) who is ill, injured, or has other health-related needs, including preventive care; or for reasons resulting from, or to assist a family member (or person who is

like family to the employee) who is a victim of, domestic violence, sexual assault, or stalking. Additional information on contractor requirements and worker protections under the EO is available at www.dol.gov/whd/govcontracts.

Unlisted classifications needed for work not included within the scope of the classifications listed may be added after award only as provided in the labor standards contract clauses (29CFR 5.5 (a) (1) (ii)).

The body of each wage determination lists the classification and wage rates that have been found to be prevailing for the cited type(s) of construction in the area covered by the wage determination. The classifications are listed in alphabetical order of "identifiers" that indicate whether the particular rate is a union rate (current union negotiated rate for local), a survey rate (weighted average rate) or a union average rate (weighted union average rate).

Union Rate Identifiers

A four letter classification abbreviation identifier enclosed in dotted lines beginning with characters other than "SU" or "UAVG" denotes that the union classification and rate were prevailing for that classification in the survey. Example: PLUM0198-005 07/01/2014. PLUM is an abbreviation identifier of the union which prevailed in the survey for this classification, which in this example would be Plumbers. 0198 indicates the local union number or district council number where applicable, i.e., Plumbers Local 0198. The next number, 005 in the example, is an internal number used in processing the wage determination. 07/01/2014 is the effective date of the most current negotiated rate, which in this example is July 1, 2014.

Union prevailing wage rates are updated to reflect all rate changes in the collective bargaining agreement (CBA) governing this classification and rate.

Survey Rate Identifiers

Classifications listed under the "SU" identifier indicate that no one rate prevailed for this classification in the survey and the published rate is derived by computing a weighted average rate based on all the rates reported in the survey for that classification. As this weighted average rate includes all rates reported in the survey, it may include both union and non-union rates. Example: SULA2012-007 5/13/2014. SU indicates the rates are survey rates based on a weighted average calculation of rates and are not majority rates. LA indicates the State of Louisiana. 2012 is the year of survey on which these classifications and rates are based. The next number, 007 in the example, is an internal number used in producing the wage determination. 5/13/2014 indicates the survey completion date for the classifications and rates under that identifier.

Survey wage rates are not updated and remain in effect until a new survey is conducted.

Union Average Rate Identifiers

Classification(s) listed under the UAVG identifier indicate that no single majority rate prevailed for those classifications; however, 100% of the data reported for the classifications was union data. EXAMPLE: UAVG-OH-0010 08/29/2014. UAVG indicates that the rate is a weighted union average rate. OH indicates the state. The next number, 0010 in the example, is an internal number used in producing the wage determination. 08/29/2014 indicates the survey completion date for the classifications and rates under that identifier.

A UAVG rate will be updated once a year, usually in January of each year, to reflect a weighted average of the current negotiated/CBA rate of the union locals from which the rate is based.

WAGE DETERMINATION APPEALS PROCESS

1.) Has there been an initial decision in the matter? This can be:

- * an existing published wage determination
- * a survey underlying a wage determination
- * a Wage and Hour Division letter setting forth a position on a wage determination matter
- * a conformance (additional classification and rate) ruling

On survey related matters, initial contact, including requests for summaries of surveys, should be with the Wage and Hour Regional Office for the area in which the survey was conducted because those Regional Offices have responsibility for the Davis-Bacon survey program. If the response from this initial contact is not satisfactory, then the process described in 2.) and 3.) should be followed.

With regard to any other matter not yet ripe for the formal process described here, initial contact should be with the Branch of Construction Wage Determinations. Write to:

Branch of Construction Wage Determinations
Wage and Hour Division
U.S. Department of Labor
200 Constitution Avenue, N.W.
Washington, DC 20210

2.) If the answer to the question in 1.) is yes, then an interested party (those affected by the action) can request review and reconsideration from the Wage and Hour Administrator (See 29 CFR Part 1.8 and 29 CFR Part 7). Write to:

Wage and Hour Administrator
U.S. Department of Labor
200 Constitution Avenue, N.W.
Washington, DC 20210

The request should be accompanied by a full statement of the interested party's position and by any information (wage payment data, project description, area practice material, etc.) that the requestor considers relevant to the issue.

3.) If the decision of the Administrator is not favorable, an interested party may appeal directly to the Administrative

Review Board (formerly the Wage Appeals Board). Write to:

Administrative Review Board
U.S. Department of Labor
200 Constitution Avenue, N.W.
Washington, DC 20210

4.) All decisions by the Administrative Review Board are final.

=====

END OF GENERAL DECISION"

CONSENT OF SURETY TO REDUCTION IN OR PARTIAL RELEASE OF RETAINAGE

TO:

PROJECT NO.

PROJECT:

Mental Health Court Public Defender's Office Buildout

CONTRACT FOR:

CONTRACT DATE:

In accordance with the provisions of the Contract between the Owner and the Contractor as indicated above, the

, SURETY,

On bond of (here insert name and address of Contractor as it appears in the bond)

, CONTRACTOR,

Hereby approves the reduction in or partial release of retainage to the contractor as follows:

The Surety agrees that such reduction in or partial release of retainage to the Contractor shall not relieve the Surety of any of its obligations to (here insert name and address of Owner)

, OWNER,

As set forth in the said Surety's bond

IN WITNESS WHEREOF,

The Surety has hereunto set its had this

day of

2021,

SURETY

Signature of Authorized Representative

Title

ATTEST:

(Seal):

CONTRACTOR'S AFFIDAVIT OF RELEASE OF LIEN:

TO (Owner):

PROJECT NO:

CONTRACT FOR:

PROJECT:

CONTRACT DATE:

Mental Health Court Public Defender's Office Buildout

State of:

County of:

The undersigned, hereby certifies that, to the best of his knowledge, information and belief, except as listed below, the Releases or Waivers of Lien attached hereto include the Contractor, all Subcontractors, all suppliers of materials and equipment, and all performers of Work, labor or services who have or may have liens against any property of the Owner arising in any manner out of the performance of the Contract referenced above.

EXCEPTIONS: (If none, write "None". If required by the Owner, the Contractor shall furnish bond satisfactory to the Owner for each exception)

SUPPORTING DOCUMENTS ATTACHED HERETO:

Contractor:

1. Contractor's Release or Waiver of Liens, Conditional upon receipt of final payment.
2. Separate Releases or Waivers of Liens from Sub-contractors and material and equipment Suppliers, to the extent required by the Owner, accompanied by a list thereof.

Address:

BY:

Subscribed and sworn to before me this day of _____, 2021.

Notary Public:

My Commission Expires:

CONTRACTOR'S AFFIDAVIT OF PAYMENT OF DEBTS AND CLAIMS

TO (Owner):

PROJECT NO:

CONTRACT FOR:

PROJECT:

CONTRACT DATE:

Mental Health Court Public Defender's Office Buildout

State of:

County of:

The undersigned, hereby certifies that, except as listed below, he has paid in full or has otherwise satisfied all obligations for all materials and equipment furnished, for all work, labor, and services performed, and for all known indebtedness and claims against the Contractor for damages arising in any manner in connection with the performance of the Contract referenced above for which the Owner or his property might in any way be held responsible.

EXCEPTIONS: (If none, write "None". If required by the Owner, the Contractor shall furnish bond satisfactory to the Owner for each exception.)

SUPPORTING DOCUMENTS ATTACHED HERETO:

CONTRACTOR:

1. Consent of Surety to Final Payment.
Whenever Surety is involved, consent of Surety is required. CONSENT OF SURETY, may be used for this purpose.
Indicate attachment; yes _____ no _____

Address:

The following supporting documents should be Attached hereto if required by the Owner:

BY:

1. Contractor's Release or Waiver of Liens, Conditional upon receipt of final payment.
2. Separate Releases or Waivers of Liens from Sub-contractors and material and equipment Suppliers to the extent required by the Owner, Accompanied by a list thereof.
3. Contractor's Affidavit of Release of Lien.

Subscribed and sworn to before me this

day of _____ 2021

Notary Public:

My Commission Expires:

CONSENT OF SURETY COMPANY TO FINAL PAYMENT

TO (Owner):

PROJECT NO:

CONTRACT FOR:

PROJECT:

CONTRACT DATE:

Mental Health Court Public Defender's Office Buildout

In accordance with the provisions of the Contract between the Owner and the Contractor as indicated above, the (here insert name and address of Surety at it appears in the bond)

, SURETY COMPANY.

On bond of (here insert name and address of Contractor)

, CONTRACTOR,

Hereby approves of the final payment to the Contractor, and agrees that final payment to the Contractor shall not relieve the Surety Company of any of its obligations to (here insert name and address of Owner)

, OWNER,

As set forth in the said Surety Company's bond.

IN WITNESS WHEREOF,

day of

, 2021.

Surety Company

Signature of Authorized Representative

Title

ATTEST:
(Seal)

NOTE: This form is to be used as a companion document to Contractor's Affidavit of Payment of Debts and Claims.

SPECIAL PROVISIONS

**REQUEST FOR PROPOSAL
MENTAL HEALTH COURT PUBLIC DEFENDER'S OFFICE BUILDOUT
GALVESTON COUNTY, TEXAS**

CONTRACT AWARD

CONTRACT FOR: Mental Health Court Public Defender's Office Buildout

THIS CONTRACT IS ENTERED INTO BETWEEN GALVESTON COUNTY AND THE CONTRACTOR NAMED BELOW PURSUANT TO SUBCHAPTER B, CHAPTER 271, TEXAS LOCAL GOVERNMENT CODE, AND THE REFERENCED INVITATION TO BID.

Contract No: CM21328

RFP No: B221004

Contractor: _____

The Specifications and Drawings are enumerated as follows:

Standard Specifications: PGAL, Inc.'s Specifications

Special Provisions: None

Special Items: None

DRAWINGS:
ADDENDA: _____

SPECIAL PROVISIONS

**REQUEST FOR PROPOSAL
MENTAL HEALTH COURT PUBLIC DEFENDER'S OFFICE BUILDOUT
GALVESTON COUNTY, TEXAS**

Contract Award (continued)

Invitation to Bid, General Provisions, Special Provisions, Bid Forms, Non-Collusion Affidavit, Vendor Qualification Packet, Debarment Form, Special Provisions for Construction, Bid Proposal, Affidavit and Surety Forms, Wage Rates, Specifications and Plans attached to this Contract Award are all made a part of this Contract and collectively evidence and constitute the entire contract. Contractor shall furnish all materials, perform all of the work required to be done and do everything else required by these documents.

Time of Completion: The Contractor shall complete the work within **180** Calendar Days of the issuance of the Notice to Proceed. The time set forth for completion of the work is an essential element of the Contract.

The Contract Sum: The County shall pay the Contractor for performance of the Contract, the sum of _____ Dollars and _____/100 (\$ _____), payments to be made as described herein.

Performance Bond required: (x) yes () no
Payment Bond required: (x) yes () no

This Contract is issued pursuant to award made by Commissioners' Court on _____, 20__.

EXECUTED this ____ day of _____, 20__.

COUNTY OF GALVESTON, TEXAS

BY: _____
MARK HENRY, County Judge

ATTEST:

DWIGHT SULLIVAN, County Clerk

CONTRACTOR

BY: _____
Signature - Title

Printed Name



Prohibition on Contracts with Certain Companies

Prohibition on contracts with certain companies per Government Code 2252.151 Definitions:

- (1) "Company" has the meaning assigned by Section 806.001.
- (2) "Foreign terrorist organization" means an organization designated as a foreign terrorist organization by the United States secretary of state as authorized by 8 U.S.C. Section 1189.
- (3) "Governmental contract" means a contract awarded by a governmental entity for general construction, an improvement, a service, or a public works project for a purchase of supplies, materials, or equipment. The term includes a contract to obtain a professional or consulting service subject to Government Code, Chapter 2254.
- (4) "Governmental entity" has the meaning assigned by Government Code, Section 2252.001.

Section 2252.152 – CONTRACTS WITH COMPANIES ENGAGED IN BUSINESS WITH IRAN, SUDAN, OR FOREIGN TERRORIST ORGANIZATION PROHIBITED. A governmental entity may not enter into a governmental contract with a company that is identified on a list prepared and maintained under Section 806.051, 807.051, or 2252.153.

Section 2252.153 – Listed Companies. The comptroller shall prepare and maintain, and make available to each governmental entity, a list of companies known to have contracts with or provide supplies or services to a foreign terrorist organization.

Pursuant to Chapter 2252, Texas Government Code, VENDOR represents and certifies that, at the time of execution of this Agreement, neither Vendor, nor any wholly owned subsidiary, majority-owned subsidiary, parent company or affiliate of the same (i) engages in business with Iran, Sudan, or any foreign terrorist organization as described in Chapters 806 or 807 of the Texas Government Code, or Subchapter F of Chapter 2252 of the Texas Government Code, or (ii) is a company listed by the Texas Comptroller of Public Accounts under Sections 806.051, 807.051, or 2252.153 of the Texas Government Code. The term "foreign terrorist organization" in this paragraph has the meaning assigned to such term in Section 2252.151 of the Texas Government Code.

Individual by oath swears that the following statements are factual and true:

1. Individual is authorized by the Contractor to make this statement for the Contractor.
2. Individual has read and is fully aware of the facts stated in this statement.
3. Individual can read and comprehend the English language.
4. As required by GOVERNMENT CODE, CHAPTER 2252.152, CONTRACTOR hereby verifies that it is not identified on a list prepared and maintained under Section 806.051, 807.051, or 2252.153, or contracting with a company doing business with Iran, Sudan, or any foreign terrorist organizations.

Date: _____

Business Name of Contractor: _____

Company Address: _____

County of Contractor: _____

Name of Individual: _____

Signature of Individual: _____



Prohibition on Contracts with Companies Boycotting Israel

Prohibition on contracts with companies boycotting Israel per Government Code 2271.001 Definitions:

- (1) "Boycott Israel" has the meaning assigned by Section 808.001.
- (2) "Company" has the meaning assigned by Section 808.001; except that the term does not include a sole proprietorship.
- (2) "Governmental entity" has the meaning assigned by Government Code, Section 2251.001.

PROVISION REQUIRED IN CONTRACT. (a) This section applies only to a contract that:

- (1) is between a governmental entity and a company with 10 or more full-time employees; and
- (2) has a value of \$100,000 or more that is to be paid wholly or partly from public funds of the governmental entity.

(b) A governmental entity may not enter into a contract with a company for goods or services unless the contract contains a written verification from the company that it:

- (1) does not boycott Israel; and
- (2) will not boycott Israel during the term of the contract.

As required by GOVERNMENT CODE, CHAPTER 2271, CONTRACTOR hereby verifies that it does not boycott Israel and will not boycott Israel throughout the term of this Agreement. For the purposes of this verification, "Boycott Israel" means refusing to deal with, terminating business activities, or otherwise taking any action that is intended to penalize, inflict economic harm on, or limit commercial relations specifically with Israel, or a person or entity doing business in Israel or in an Israeli-controlled territory, but does not include an action made for ordinary business purposes.

Individual by oath swears that the following statements are factual and true:

1. Individual is authorized by the Contractor to make this statement for the Contractor.
2. Individual has read and is fully aware of the facts stated in this statement.
3. Individual can read and comprehend the English language.
4. In accordance with Texas Government Code Section 2271.002, this company does not boycott Israel and will not boycott Israel during the term of this contract/agreement.

Date: _____

Business Name of Contractor: _____

Company Address: _____

County of Contractor: _____

A Individual: _____

Signature of Individual: _____

State of Texas

§

County of Galveston

§

§

NON-COLLUSION AFFIDAVIT

Before me, the undersigned notary, on this day personally appeared _____ (Affiant), whom being first duly sworn, deposes and certifies that:

- Affiant is the _____ of _____, that
(Individual, Partner, Corporate Officer) (Name of Qualifier)
submitted the attached Qualification in **RFP #B221004, Mental Health Court Public Defender’s Office Buildout**
- Affiant is a duly authorized representative of Qualifier and is authorized to make this Non-Collusion Affidavit;
- The attached Qualification is genuine and is not a collusive or sham Qualification;
- The attached Qualification has been independently arrived at without collusion with any other qualifier, bidder, proposer, person, firm, competitor, or potential competitor;
- Qualifier has not colluded, conspired, connived or agreed, directly or indirectly, with any other qualifier, bidder, proposer, person, firm, competitor, or potential competitor, to submit a collusive or sham qualification or that such other qualifier, bidder, proposer, person, firm, competitor, or potential competitor shall refrain from qualifying;
- Qualifier has not in any manner, directly or indirectly, sought by agreement or collusion or communication or conference with any other qualifier, bidder, proposer, person, firm, competitor, or potential competitor to fix the price or prices in the attached Qualification or of the qualification any other qualifier;
- Qualifier has not in any manner, directly or indirectly, sought by agreement or collusion or communication or conference with any other qualifier bidder, proposer, person, firm, competitor, or potential competitor to fix the overhead, profit or cost element of the Qualification price or prices of any other qualifier, or to secure through any collusion, conspiracy, connivance, or unlawful agreement any advantage against Galveston County or any person interested in the proposed contract;
- Affiant has not in any manner, directly or indirectly, sought by agreement or collusion or communication or conference with any other qualifier, bidder, proposer, person, firm, competitor, or potential competitor, paid or agreed to pay any other qualifier, bidder, proposer, person, firm, competitor, or potential competitor any money or anything of value in return for assistance in procuring or attempting to procure a contract or in return for establishing the price or prices in the attached Qualification or the qualification of any other Qualifier; and
- Affiant certifies that Affiant is fully informed regarding the accuracy of the statements contained herein, and under penalties of perjury, certifies and affirms the truth of the statements herein, such penalties being applicable to the Qualifier as well as to Affiant signing on its behalf.

Signature of Affiant

SWORN TO and SUBSCRIBED before me this _____ day of _____, _____.

Notary Public

My Commission Expires: _____

CERTIFICATION REGARDING LOBBYING
(31 U.S.C.A. § 1352)
This Certification must be completed, signed, dated and
returned to the Galveston County Purchasing Agent

Procurement Number and Description: _____

RFP #B221004, Mental Health Court Public Defender's Office Buildout _____

Proposer **CERTIFIES**, to the best of its knowledge and belief, that:

1. No Federal appropriated funds have been paid or will be paid, by or on behalf of the proposer, to any person for influencing or attempting to influence an officer or employee of an agency, a Member of Congress, an officer or employee of Congress, or an employee of a Member of Congress in connection with the awarding of any Federal contract, the making of any Federal grant, the making of any Federal loan, the entering into of any cooperative agreement, and the extension, continuation, renewal, amendment, or modification of any Federal contract, grant, loan, or cooperative agreement.
2. If any funds other than Federal appropriated funds have been paid or will be paid to any person for influencing or attempting to influence an officer or employee of any agency, a Member of Congress, an officer or employee of Congress, or an employee of a Member of Congress in connection with this Federal contract, grant, loan, or cooperative agreement, the proposer shall complete and submit **Standard Form LLL**, "Disclosure Form to Report Lobbying", in accordance with its instructions.
3. Proposer shall require that the language of this certification be included in the award documents for all subawards at all tiers (including subcontracts, subgrants, and contracts under grants, loans, and cooperative agreements) and that all subrecipients shall certify and disclose accordingly.

This certification is a material representation of fact upon which reliance was placed when this transaction was made or entered into. Submission of this certification is a prerequisite for making or entering into this transaction imposed by Section 1352, Title 31, U.S. Code. Any person who fails to file the required certification shall be subject to a civil penalty of not less than \$10,000 and not more than \$100,000 for each such failure.

Name of Organization/Corporation: _____

Address: _____

City: _____ State: _____ Zip Code: _____

Signature of Authorized Signatory for Proposer: _____ Date Signed: _____

Title of Authorized Signatory of Proposer: _____

**GALVESTON COUNTY, TEXAS
MENTAL HEALTH COURT PUBLIC DEFENDER'S OFFICE BUILDOUT
PROPOSAL FORM**

THE COMPANY OF: _____

Address: _____

FEIN (TAX ID): _____

The following shall be returned with your bid. Failure to do so may be ample cause for rejection of bid as non responsive. It is the responsibility of the Bidder to ensure that Bidder has received all addenda.

- | Items: | Confirmed (X): |
|--|---------------------------------|
| 1. References (if required) | _____ |
| 2. Addenda, if any | #1_____ #2_____ #3_____ #4_____ |
| 3. One (1) original and five (5) copies of submittal | _____ |
| 4. Proposal Forms | _____ |
| 5. Vendor Qualification packet | _____ |
| 6. Payment Terms: | _____ net 30 _____ Other |
| 7. Non-Collusion Affidavit | _____ |
| 8. Debarment Form | _____ |
| 9. Lobbying Certificate | _____ |
| 10. Companies Boycotting Israel | _____ |
| 11. Contracts with Certain Companies | _____ |
| 12. Contractor's Certification | _____ |

Person to contact regarding this proposal: _____

Title: _____ Phone: _____ Fax: _____

E-mail address: _____

Name of person authorized to bind the Firm: _____

Signature: _____ Date: _____

Title: _____ Phone: _____ Fax: _____

E-mail address: _____

**GALVESTON COUNTY, TEXAS
MENTAL HEALTH COURT PUBLIC DEFENDER'S OFFICE BUILDOUT
PROPOSAL FORM**

Proposer shall use this form to provide the information for notice.

1. Contact information for notice:

Name: _____
Address: _____
Telephone Number: _____ Facsimile number: _____

2. If a copy of notice is requested, please complete below:

Name: _____
Address: _____
Telephone Number: _____ Facsimile number: _____

3. If second or more copies are requested for notice, please supplement this form and clearly mark the supplement as "Supplementary Notice Information."

Proposer to submit reference information. Proposer shall use this form to provide minimum required reference information. If Proposer wishes to provide more than the minimum, Proposer should supplement this form and should clearly mark the supplement as "Supplementary Reference Information."

1. References who can attest to the Proposer's capability to carry out the requirements set forth in this qualification:

Business Name of Organization: _____
Name of Person: _____
Title of Individual within Organization, if applicable _____
Business address: _____
Telephone number: _____ Facsimile number: _____

Business Name of Organization: _____
Name of Person: _____
Title of Individual within Organization, if applicable _____
Business address: _____
Telephone number: _____ Facsimile number: _____

Business Name of Organization: _____
Name of Person: _____
Title of Individual within Organization, if applicable _____
Business address: _____
Telephone number: _____ Facsimile number: _____

PROPOSAL FORM
MENTAL HEALTH COURT PUBLIC DEFENDER'S OFFICE BUILDOUT
GALVESTON, TEXAS

References of major supplier of Proposer who can speak to the financial capability of the Proposer to carry out the requirements set forth in this qualification:

1. Business Name of Supplier _____
Name of Person: _____
Title of Individual within business: _____
Business address: _____

Telephone number: _____ Facsimile number: _____

2. Business Name of Supplier _____
Name of Person: _____
Title of Individual within business: _____
Business address: _____

Telephone number: _____ Facsimile number: _____

3. Business Name of Supplier _____
Name of Person: _____
Title of Individual within business: _____
Business address: _____

Telephone number: _____ Facsimile number: _____

The remainder of this page intentionally left blank



County of Galveston

**ACKNOWLEDGMENT AND CERTIFICATION REGARDING DEBARMENT,
SUSPENSION, AND OTHER INELGIBILITY**

Executive Orders 12549 & 12689 Certification, Debarment and Suspension

Solicitation Number: RFP #B221004

Solicitation Title: Mental Health Court Public Defender's Office Buildout

Contractor hereby CERTIFIES that:

Contractor, and all of its principals, is not presently debarred, suspended, proposed for debarment, proposed for suspension, or declared ineligible under Executive Order 12549 or Executive Order 12689, Debarment and Suspension, and is not in any other way ineligible for participation in Federal or State assistance programs;

Contractor, and all of its principals, were not and have not been debarred, suspended, proposed for debarment, proposed for suspension, or declared ineligible under Executive Order 12549 or Executive Order 12689, Debarment and Suspension, and were not and have not been in any other way ineligible for participation in Federal or State assistance programs at the time its' proposal was submitted in the procurement identified herein and at any time since submission of its' proposal;

Contractor has included, and shall continue to include, this certification in all contracts between itself and any sub-contractors in connection with services performed under this contract; **and**

Contractor shall notify Galveston County in writing immediately, through written notification to the Galveston County Purchasing Agent, if Contractor is not in compliance with Executive Order 12549 or 12689 during the term of its contract with Galveston County.

Contractor **Represents** and **Warrants** that the individual executing this Acknowledgment and Certification on its behalf has the full power and authority to do so and can legally bind the Contractor hereto.

Name of Business

Date

By: _____
Signature

Printed Name & Title

CONTRACTOR'S CERTIFICATION of RECOVERED MATERIAL

ACKNOWLEDGEMENT

I, _____ (Principal's Name) _____ of _____ (Company Name) _____, (hereinafter called "Contractor"), acknowledge the recovered material bidding requirements found in 2 CFR 200.322 that requires the Contractor to procure those items designated in the guidelines of the Environmental Protection Agency (EPA) at 40 CFR 247 that contain the highest percentage of recovered materials practicable, consistent with maintaining a satisfactory level of competition.

I also acknowledge that this requirement shall apply to items purchased (1) where the Contractor purchases in excess of \$10,000 of the item under this contract; or (2) where during the preceding fiscal year, the value of the quantity acquired was in excess of \$10,000.

Finally, I acknowledge the attached list of recovered materials included in the bid documents. (For up-to-date listing, please go to <https://www.epa.gov/smm/comprehensive-procurement-guideline-cpg-program#directory>)

Printed Name and Title

Signature

Date

USE OF RECOVERED MATERIAL

Please check one:

- Recovered materials are included in this bid:
Materials included _____
- Recovered materials are not reasonably available in a reasonable period of time.
- Recovered materials fail to meet reasonable performance standards, which are determined on the basis of the guidelines of the National Institute of Standards and Technology, if applicable.
- Recovered materials are only available at an unreasonable price.

Printed Name and Title

Signature

Date

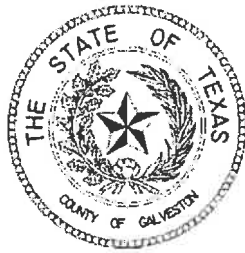

County of Galveston Purchasing Department Vendor Qualification Packet

(rev. 1.4, September 28, 2017)

All interested parties seeking consideration for qualified vendor status with the County of Galveston should complete and return only the following forms to:

Galveston County Purchasing Department
722 Moody Avenue, (21st Street), 5th Floor
Galveston, Texas 77550
(409) 770-5371 office
(409) 621-7987 fax

- PEID Form:** Person /Entity Information Data
- W -9 Form:** Request for Taxpayer Identification Number and Certification
(please note that the included form may not be the latest revised form issued by the Internal Revenue Service. Please check the IRS website at <http://www.irs.gov/pub/irs-rd/ffw9.pdf> for the latest revision of this form.)
- CIQ Form:** Conflict of Interest Questionnaire
(please note that the included form may not be the latest revised form issued by the State of Texas Ethics Commission. Please check the Texas Ethics Commission website at http://www.ethics.state.tx.us/whatsnew/conflict_forms.htm for the latest revision of this form. Please note that Galveston County Purchasing Agent is not responsible for the filing of this form with the Galveston County Clerk per instructions of the State of Texas Ethics Commission).
- Debarment:** **CERTIFICATION REGARDING DEBARMENT, SUSPENSION, PROPOSED DEBARMENT, AND OTHER RESPONSIBILITY MATTERS & REQUIREMENT TO REGISTER IN SAM**
*Vendors/contractor certifies that neither it, nor any of its Principals, are presently debarred, suspended, proposed for debarment, disqualified, excluded, or in any way declared ineligible for the award of contracts by any Federal agency. Vendor agrees that it shall refund Galveston County for any payments made to Contractor while ineligible. Vendor acknowledges that Contractor's uncured failure to perform under any agreement with the County of Galveston, if such should occur, may result in Contractor being debarred from performing additional work for the County, the respecting State Agency administering the grant funding the contract, if applicable, the State, FEMA or HUD (as applicable), and other Federal and State entities. Further, Vendor has executed the Certification Regarding Debarment, Suspension, Proposed Debarment, and Other Responsibility Matters and returned the fully completed and executed original certification with the submission of this Vendor Qualification Packet. **The truthful and fully completed and executed original of the Certification Regarding Debarment, Suspension, Proposed Debarment, and Other Responsibility Matters must be included with the submission of this Vendor Qualification Packet and is a mandatory requirement to become a vendor of Galveston County. Vendor's failure to include the fully completed and executed original of this Certification shall be considered non-compliant with the requirements of this vendor qualification request and grounds for the rejection of vendor's request. Vendor shall immediately notify the County Purchasing Agent if it becomes debarred or suspended, placed on***

the Consolidated List of Debarred Contractors, or in any other way becomes ineligible for award of contract by any Federal agency. This Certification is a material fact relied upon by Galveston County; if it is later determined that the vendor did not comply with 2 C. F. R. Part 180 and 2 C.F.R. Part 3000, in addition to the remedies available to Galveston County and the State agency administering a grant, the Federal Government may pursue available remedies, including but not limited to suspension and/or debarment of contractor. If the contract to be awarded pursuant to a Galveston County procurement effort involves the use of Federal funds, then vendor must also be registered in the Federal Contractor Registry through the System for Award Management (SAM) to be eligible for award of contract pursuant to the procurement.

Information regarding the SAM is available at:

<http://federalcontractorregistry.com/?gclid=CIGlhf2rr8wCFYkCaQoducANZw> or at <http://sam.gov/portal/SAM/#1>.

No contract involving the use of Federal funds may be awarded to any vendor unless and until such registration is current and in good standing under SAM Successful vendors must maintain SAM registration throughout the entire term of any contractual agreement with the County. If a contract involves the use of Federal funds, then vendor must enclose proof of such SAM registration within its response, which is also a mandatory requirement of County procurement policy; failure to enclose such proof shall be considered non-compliant with the requirements of any procurement effort and grounds for the rejection of vendor's response to any procurement efforts (i.e., bid, proposal, or qualifications statement, as applicable).

Direct Deposit: Direct Deposit Authorization Form – Temporarily suspended until further notice

Certificate(s) of Insurance: If the person or entity seeking qualified vendor status with the County will be performing work at or on any County owned facility and/or property, Certificate(s) of Insurance are required to be submitted prior to performing any work.

Insurance requirements are as follows:

Public Liability and Property Damage Insurance:

Successful vendor agrees to keep in full force and effect, a policy of public liability and property damage insurance issued by a casualty company authorized to do business in the State of Texas, and in standard form approved by the Board of Insurance Commissioners of the State of Texas, with coverage provisions insuring the public from any loss or damage that may arise to any person or property by reason of services rendered by vendor. Vendor shall at its own expense be required to carry the following minimum insurance coverages:

1. For damages arising out of bodily injury to or death of one person in anyone occurrence - one hundred thousand and no/100 dollars (\$100,000.00);
2. For damages arising out of bodily injury to or death of two or more persons in anyone occurrence - three hundred thousand and no/100 dollars (\$300,000.00); and
3. For injury to or destruction of property in anyone occurrence - one hundred thousand and no/100 dollars (\$100,000.00).

This insurance shall be either on an occurrence basis or on a claims made basis. Provided however, that if the coverage is on a claims made basis, then the vendor shall be required to purchase, at the termination of this agreement, tail coverage for the County for the period of the County's relationship with the vendor under this agreement. Such coverage shall be in the amounts set forth in subparagraphs (1), (2), and (3) above.

Worker's Compensation Insurance:

Successful vendor shall also carry in full force Workers' Compensation Insurance policy(ies), if there is more than one employee, for all employees, including but not limited to full time, part time, and emergency employees employed by the vendor. Current insurance certificates certifying that such policies as specified above are in full force and effect shall be furnished by the vendor to the County.

The County of Galveston shall be named as additional insured on policies listed in subparagraphs above and shall be notified of any changes to the policy(ies) during the contractual period.

Insurance is to be placed with insurers having a Best rating of no less than A. The vendor shall furnish the County with certificates of insurance and original endorsements affecting coverage required by these insurance clauses. The certificates and endorsements for each insurance policy are to be signed by a person authorized by the insurer to bind coverage on its behalf. The vendor shall be required to submit annual renewals for the term of any contractual agreement, purchase order or term contract, with Galveston County prior to expiration of any policy.

In addition to the remedies stated herein, the County has the right to pursue other remedies permitted by law or in equity.

The County agrees to provide vendor with reasonable and timely notice of any claim, demand, or cause of action made or brought against the County arising out of or related to utilization of the property. Vendor shall have the right to defend any such claim, demand, or cause of action at its sole cost and expense and within its sole and exclusive discretion. The County agrees not to compromise or settle any claim or cause of action arising out of or related to the utilization of the property without the prior written consent of the vendor.

In no event shall the County be liable for any damage to or destruction of any property belonging to the vendor unless specified in writing and agreed upon by both parties.

Procurement Policy - Special Note:

Understand that it is, according to Texas Local Government Code, Section 262.011, Purchasing Agents, subsections (d), (e), and (0), the sole responsibility of the Purchasing Agent to supervise all procurement transactions.

Therefore, be advised that all procurement transactions require proper authorization in the form of a Galveston County purchase order from the Purchasing Agent's office prior to commitment to deliver supplies, materials, equipment, including contracts for repair, service, and maintenance agreements. Any commitments made without proper authorization from the Purchasing Agent's office, pending Commissioners' Court approval, may become the sole responsibility of the individual making the commitment including the obligation of payment.

Code of Ethics - Statement of Purchasing Policy:

Public employment is a public trust. It is the policy of Galveston County to promote and balance the objective of protecting the County's integrity and the objective of facilitating the recruitment and retention of personnel needed by Galveston County. Such policy is implemented by prescribing essential standards of ethical conduct without creating unnecessary obstacles to entering public office.

Public employees must discharge their duties impartially so as to assure fair competitive access to governmental procurement by responsible contractors. Moreover, they should conduct themselves in such a manner as to foster public confidence in the integrity of the Galveston County procurement organization.

To achieve the purpose of these instructions, it is essential that those doing business with Galveston County also observe the ethical standards prescribed here.

General Ethical Standards: It shall be a breach of ethics to attempt to realize personal gain through public employment with Galveston County by any conduct inconsistent with the proper discharge of the employee's duties.

It shall be a breach of ethics to attempt to influence any public employee of Galveston County to breach the standards of ethical conduct set forth in this code.

It shall be a breach of ethics for any employee of Galveston County to participate directly or indirectly in procurement when the employee knows that:

- The employee or any member of the employee's immediate family has a financial interest pertaining to the procurement.
- A business or organization in which the employee, or any member of the employee's immediate family, has a financial interest pertaining to the procurement.
- Any other person, business or organization with which the employee or any member of the employee's immediate family is negotiating or has an arrangement concerning prospective employment is involved in the procurement.

Gratuities: It shall be a breach of ethics to offer, give or agree to give any employee of Galveston County, or for any employee or former employee of Galveston County to solicit, demand, accept or agree to accept from another person, a gratuity or an offer of employment in connection with any decision, approval, disapproval, recommendation, preparation of any part of a program requirement or purchase request, influencing the content of any specification or procurement standard, rendering of advice, investigation, auditing, or in any other advisory capacity in any program requirement or a contract or subcontract, or to any solicitation or proposal therefore pending before this government.

Kickbacks: It shall be a breach of ethics for any payment, gratuity or offer of employment to be made by or on behalf of a subcontractor under a contract to the prime contractor or higher tier subcontractor for any contract for Galveston County, or any person associated therewith, as an inducement for the award of a subcontract or order.

Contract Clause: The prohibition against gratuities and kickbacks prescribed above shall be conspicuously set forth in every contract and solicitation by Galveston County.

Confidential Information: It shall be a breach of ethics for any employee or former employee of Galveston County to knowingly use confidential information for actual or anticipated personal gain, or for the actual or anticipated gain of any person.

Questions/Concerns:

If you have any questions or concerns regarding the information or instructions contained within this packet, please contact any member of the Purchasing Department staff at **(409) 770-5371**.

CONFLICT OF INTEREST DISCLOSURE REPORTING

Proposer may be required under Chapter 176 of the Texas Local Government Code to complete and file a conflict of interest questionnaire (CIQ Form). If so, the completed CIQ Form must be filed with the County Clerk of Galveston County, Texas.

If Proposer has an employment or other business relationship with an officer of Galveston County or with a family member of an officer of Galveston County that results in the officer or family member of the officer receiving taxable income that exceeds \$2,500.00 during the preceding 12-month period, then Proposer **MUST** complete a CIQ Form and file the original of the CIQ Form with the County Clerk of Galveston County.

If Proposer has given an officer of Galveston County or a family member of an officer of Galveston County one or more gifts with an aggregate value of more than \$250.00 during the preceding 12-months, then Proposer **MUST** complete a CIQ Form and file the original of the CIQ Form with the County Clerk of Galveston County

The Galveston County Clerk has offices at the following locations:

Galveston County Clerk
Galveston County Justice Center, Suite 2001
600 59th Street
Galveston, Texas 77551

Galveston County Clerk
North County Annex, 1st Floor
174 Calder Road
League City, Texas 77573

Again, if Proposer is required to file a CIQ Form, the original completed form is filed with the Galveston County Clerk (not the Purchasing Agent).

For Proposer's convenience, a blank CIQ Form is enclosed with this proposal. Blank CIQ Forms may also be obtained by visiting the Galveston County Clerk's website and/or the Purchasing Agent's website - both of these web sites are linked to the Galveston County homepage at <http://www.galvestoncountytexas.gov>

As well, blank CIQ Forms may be obtained by visiting the Texas Ethics Commission website, specifically at <http://www.ethics.state.tx.us/whatsnew/conflictfroms.htm>

Chapter 176 specifies deadlines for the filing of CIQ Forms (both initial filings and updated filings).

It is Proposer's sole responsibility to file a true and complete CIQ Form with the Galveston County Clerk if Proposer is required to file by the requirements of Chapter 176. Proposer is advised that it is an offense to fail to comply with the disclosure reporting requirements dictated under Chapter 176 of the Texas Local Government Code.

If you have questions about compliance with Chapter 176, please consult your own legal counsel. Compliance is the individual responsibility of each person, business, and agent who is subject to Chapter 176 of the Texas Local Government Code.



COUNTY of GALVESTON
Purchasing Department

rev. 1.3, March 29, 2010

FORM PEID:	Request for Person-Entity Identification Data
-------------------	--

Instructions: Please type or print clearly when completing sections 1 thru 4 and return completed form to:

Galveston County Purchasing Agent
 722 Moody Avenue (21 st. Street), 5th Floor
 Galveston, Texas 77550
 (409) 770-5371
prodoc@co.galveston.tx.us

1.	Business Name:			
	Attention Line:			
2.	Physical Address:			
	City:	State:	Zip+4:	
3.	Billing / Remit Address:			
	City:	State:	Zip+4	
4.	Main Contact Person:			
	Main Phone Number:			
	Fax Number:			
	E-mail Address:			

Areas below are for County use only.

Requested By:	Phone / Ext. #	
Department:	Date:	
Action Requested - Check One:	IFAS PEID Vendor Number:	
<input type="checkbox"/> Add New	<input type="checkbox"/> Change Data	<input type="checkbox"/> Re-activate
<input type="checkbox"/> Inactivate	<input type="checkbox"/> Employee	<input type="checkbox"/> Attorney
<input type="checkbox"/> Landlord	<input type="checkbox"/> Foster Parent	<input type="checkbox"/> Refund
<input type="checkbox"/> OneTime	<input type="checkbox"/> Foster Child	

Request for Taxpayer Identification Number and Certification

**Give Form to the
requester. Do not
send to the IRS.**

▶ Go to www.irs.gov/FormW9 for instructions and the latest information.

Print or type.
See Specific Instructions on page 3.

	1 Name (as shown on your income tax return). Name is required on this line; do not leave this line blank.	
	2 Business name/disregarded entity name, if different from above	
	3 Check appropriate box for federal tax classification of the person whose name is entered on line 1. Check only one of the following seven boxes. <input type="checkbox"/> Individual/sole proprietor or single-member LLC <input type="checkbox"/> C Corporation <input type="checkbox"/> S Corporation <input type="checkbox"/> Partnership <input type="checkbox"/> Trust/estate <input type="checkbox"/> Limited liability company. Enter the tax classification (C=C corporation, S=S corporation, P=Partnership) ▶ _____ Note: Check the appropriate box in the line above for the tax classification of the single-member owner. Do not check LLC if the LLC is classified as a single-member LLC that is disregarded from the owner unless the owner of the LLC is another LLC that is not disregarded from the owner for U.S. federal tax purposes. Otherwise, a single-member LLC that is disregarded from the owner should check the appropriate box for the tax classification of its owner. <input type="checkbox"/> Other (see instructions) ▶ _____	4 Exemptions (codes apply only to certain entities, not individuals; see instructions on page 3): Exempt payee code (if any) _____ Exemption from FATCA reporting code (if any) _____ <small>(Applies to accounts maintained outside the U.S.)</small>
	5 Address (number, street, and apt. or suite no.) See instructions.	Requester's name and address (optional)
	6 City, state, and ZIP code	
	7 List account number(s) here (optional)	

Part I Taxpayer Identification Number (TIN)

Enter your TIN in the appropriate box. The TIN provided must match the name given on line 1 to avoid backup withholding. For individuals, this is generally your social security number (SSN). However, for a resident alien, sole proprietor, or disregarded entity, see the instructions for Part I, later. For other entities, it is your employer identification number (EIN). If you do not have a number, see *How to get a TIN*, later.

Note: If the account is in more than one name, see the instructions for line 1. Also see *What Name and Number To Give the Requester* for guidelines on whose number to enter.

Social security number								
<table style="width: 100%; border-collapse: collapse;"> <tr> <td style="width: 25%; border: 1px solid black; height: 20px;"></td> <td style="width: 25%; border: 1px solid black; height: 20px;"></td> <td style="width: 25%; border: 1px solid black; height: 20px;"></td> <td style="width: 25%; border: 1px solid black; height: 20px;"></td> </tr> <tr> <td style="text-align: center;">-</td> <td style="text-align: center;">-</td> <td></td> <td></td> </tr> </table>					-	-		
-	-							
or								
Employer identification number								
<table style="width: 100%; border-collapse: collapse;"> <tr> <td style="width: 25%; border: 1px solid black; height: 20px;"></td> <td style="width: 25%; border: 1px solid black; height: 20px;"></td> <td style="width: 25%; border: 1px solid black; height: 20px;"></td> <td style="width: 25%; border: 1px solid black; height: 20px;"></td> </tr> <tr> <td style="text-align: center;">-</td> <td></td> <td></td> <td></td> </tr> </table>					-			
-								

Part II Certification

Under penalties of perjury, I certify that:

1. The number shown on this form is my correct taxpayer identification number (or I am waiting for a number to be issued to me); and
2. I am not subject to backup withholding because: (a) I am exempt from backup withholding, or (b) I have not been notified by the Internal Revenue Service (IRS) that I am subject to backup withholding as a result of a failure to report all interest or dividends, or (c) the IRS has notified me that I am no longer subject to backup withholding; and
3. I am a U.S. citizen or other U.S. person (defined below); and
4. The FATCA code(s) entered on this form (if any) indicating that I am exempt from FATCA reporting is correct.

Certification instructions. You must cross out item 2 above if you have been notified by the IRS that you are currently subject to backup withholding because you have failed to report all interest and dividends on your tax return. For real estate transactions, item 2 does not apply. For mortgage interest paid, acquisition or abandonment of secured property, cancellation of debt, contributions to an individual retirement arrangement (IRA), and generally, payments other than interest and dividends, you are not required to sign the certification, but you must provide your correct TIN. See the instructions for Part II, later.

Sign Here

Signature of
U.S. person ▶

Date ▶

General Instructions

Section references are to the Internal Revenue Code unless otherwise noted.

Future developments. For the latest information about developments related to Form W-9 and its instructions, such as legislation enacted after they were published, go to www.irs.gov/FormW9.

Purpose of Form

An individual or entity (Form W-9 requester) who is required to file an information return with the IRS must obtain your correct taxpayer identification number (TIN) which may be your social security number (SSN), individual taxpayer identification number (ITIN), adoption taxpayer identification number (ATIN), or employer identification number (EIN), to report on an information return the amount paid to you, or other amount reportable on an information return. Examples of information returns include, but are not limited to, the following.

- Form 1099-INT (interest earned or paid)

- Form 1099-DIV (dividends, including those from stocks or mutual funds)
- Form 1099-MISC (various types of income, prizes, awards, or gross proceeds)
- Form 1099-B (stock or mutual fund sales and certain other transactions by brokers)
- Form 1099-S (proceeds from real estate transactions)
- Form 1099-K (merchant card and third party network transactions)
- Form 1098 (home mortgage interest), 1098-E (student loan interest), 1098-T (tuition)
- Form 1099-C (canceled debt)
- Form 1099-A (acquisition or abandonment of secured property)

Use Form W-9 only if you are a U.S. person (including a resident alien), to provide your correct TIN.

If you do not return Form W-9 to the requester with a TIN, you might be subject to backup withholding. See What is backup withholding, later.

By signing the filled-out form, you:

1. Certify that the TIN you are giving is correct (or you are waiting for a number to be issued),
2. Certify that you are not subject to backup withholding, or
3. Claim exemption from backup withholding if you are a U.S. exempt payee. If applicable, you are also certifying that as a U.S. person, your allocable share of any partnership income from a U.S. trade or business is not subject to the withholding tax on foreign partners' share of effectively connected income, and
4. Certify that FATCA code(s) entered on this form (if any) indicating that you are exempt from the FATCA reporting, is correct. See *What is FATCA reporting*, later, for further information.

Note: If you are a U.S. person and a requester gives you a form other than Form W-9 to request your TIN, you must use the requester's form if it is substantially similar to this Form W-9.

Definition of a U.S. person. For federal tax purposes, you are considered a U.S. person if you are:

- An individual who is a U.S. citizen or U.S. resident alien;
- A partnership, corporation, company, or association created or organized in the United States or under the laws of the United States;
- An estate (other than a foreign estate); or
- A domestic trust (as defined in Regulations section 301.7701-7).

Special rules for partnerships. Partnerships that conduct a trade or business in the United States are generally required to pay a withholding tax under section 1446 on any foreign partners' share of effectively connected taxable income from such business. Further, in certain cases where a Form W-9 has not been received, the rules under section 1446 require a partnership to presume that a partner is a foreign person, and pay the section 1446 withholding tax. Therefore, if you are a U.S. person that is a partner in a partnership conducting a trade or business in the United States, provide Form W-9 to the partnership to establish your U.S. status and avoid section 1446 withholding on your share of partnership income.

In the cases below, the following person must give Form W-9 to the partnership for purposes of establishing its U.S. status and avoiding withholding on its allocable share of net income from the partnership conducting a trade or business in the United States.

- In the case of a disregarded entity with a U.S. owner, the U.S. owner of the disregarded entity and not the entity;
- In the case of a grantor trust with a U.S. grantor or other U.S. owner, generally, the U.S. grantor or other U.S. owner of the grantor trust and not the trust; and
- In the case of a U.S. trust (other than a grantor trust), the U.S. trust (other than a grantor trust) and not the beneficiaries of the trust.

Foreign person. If you are a foreign person or the U.S. branch of a foreign bank that has elected to be treated as a U.S. person, do not use Form W-9. Instead, use the appropriate Form W-8 or Form 8233 (see Pub. 515, *Withholding of Tax on Nonresident Aliens and Foreign Entities*).

Nonresident alien who becomes a resident alien. Generally, only a nonresident alien individual may use the terms of a tax treaty to reduce or eliminate U.S. tax on certain types of income. However, most tax treaties contain a provision known as a "saving clause." Exceptions specified in the saving clause may permit an exemption from tax to continue for certain types of income even after the payee has otherwise become a U.S. resident alien for tax purposes.

If you are a U.S. resident alien who is relying on an exception contained in the saving clause of a tax treaty to claim an exemption from U.S. tax on certain types of income, you must attach a statement to Form W-9 that specifies the following five items.

1. The treaty country. Generally, this must be the same treaty under which you claimed exemption from tax as a nonresident alien.
2. The treaty article addressing the income.
3. The article number (or location) in the tax treaty that contains the saving clause and its exceptions.
4. The type and amount of income that qualifies for the exemption from tax.
5. Sufficient facts to justify the exemption from tax under the terms of the treaty article.

Example. Article 20 of the U.S.-China income tax treaty allows an exemption from tax for scholarship income received by a Chinese student temporarily present in the United States. Under U.S. law, this student will become a resident alien for tax purposes if his or her stay in the United States exceeds 5 calendar years. However, paragraph 2 of the first Protocol to the U.S.-China treaty (dated April 30, 1984) allows the provisions of Article 20 to continue to apply even after the Chinese student becomes a resident alien of the United States. A Chinese student who qualifies for this exception (under paragraph 2 of the first protocol) and is relying on this exception to claim an exemption from tax on his or her scholarship or fellowship income would attach to Form W-9 a statement that includes the information described above to support that exemption.

If you are a nonresident alien or a foreign entity, give the requester the appropriate completed Form W-8 or Form 8233.

Backup Withholding

What is backup withholding? Persons making certain payments to you must under certain conditions withhold and pay to the IRS 24% of such payments. This is called "backup withholding." Payments that may be subject to backup withholding include interest, tax-exempt interest, dividends, broker and barter exchange transactions, rents, royalties, nonemployee pay, payments made in settlement of payment card and third party network transactions, and certain payments from fishing boat operators. Real estate transactions are not subject to backup withholding.

You will not be subject to backup withholding on payments you receive if you give the requester your correct TIN, make the proper certifications, and report all your taxable interest and dividends on your tax return.

Payments you receive will be subject to backup withholding if:

1. You do not furnish your TIN to the requester,
2. You do not certify your TIN when required (see the instructions for Part II for details),
3. The IRS tells the requester that you furnished an incorrect TIN,
4. The IRS tells you that you are subject to backup withholding because you did not report all your interest and dividends on your tax return (for reportable interest and dividends only), or
5. You do not certify to the requester that you are not subject to backup withholding under 4 above (for reportable interest and dividend accounts opened after 1983 only).

Certain payees and payments are exempt from backup withholding. See *Exempt payee code*, later, and the separate Instructions for the Requester of Form W-9 for more information.

Also see *Special rules for partnerships*, earlier.

What is FATCA Reporting?

The Foreign Account Tax Compliance Act (FATCA) requires a participating foreign financial institution to report all United States account holders that are specified United States persons. Certain payees are exempt from FATCA reporting. See *Exemption from FATCA reporting code*, later, and the Instructions for the Requester of Form W-9 for more information.

Updating Your Information

You must provide updated information to any person to whom you claimed to be an exempt payee if you are no longer an exempt payee and anticipate receiving reportable payments in the future from this person. For example, you may need to provide updated information if you are a C corporation that elects to be an S corporation, or if you no longer are tax exempt. In addition, you must furnish a new Form W-9 if the name or TIN changes for the account; for example, if the grantor of a grantor trust dies.

Penalties

Failure to furnish TIN. If you fail to furnish your correct TIN to a requester, you are subject to a penalty of \$50 for each such failure unless your failure is due to reasonable cause and not to willful neglect.

Civil penalty for false information with respect to withholding. If you make a false statement with no reasonable basis that results in no backup withholding, you are subject to a \$500 penalty.

Criminal penalty for falsifying information. Willfully falsifying certifications or affirmations may subject you to criminal penalties including fines and/or imprisonment.

Misuse of TINs. If the requester discloses or uses TINs in violation of federal law, the requester may be subject to civil and criminal penalties.

Specific Instructions

Line 1

You must enter one of the following on this line; **do not** leave this line blank. The name should match the name on your tax return.

If this Form W-9 is for a joint account (other than an account maintained by a foreign financial institution (FFI)), list first, and then circle, the name of the person or entity whose number you entered in Part I of Form W-9. If you are providing Form W-9 to an FFI to document a joint account, each holder of the account that is a U.S. person must provide a Form W-9.

a. **Individual.** Generally, enter the name shown on your tax return. If you have changed your last name without informing the Social Security Administration (SSA) of the name change, enter your first name, the last name as shown on your social security card, and your new last name.

Note: ITIN applicant: Enter your individual name as it was entered on your Form W-7 application, line 1a. This should also be the same as the name you entered on the Form 1040/1040A/1040EZ you filed with your application.

b. **Sole proprietor or single-member LLC.** Enter your individual name as shown on your 1040/1040A/1040EZ on line 1. You may enter your business, trade, or “doing business as” (DBA) name on line 2.

c. **Partnership, LLC that is not a single-member LLC, C corporation, or S corporation.** Enter the entity’s name as shown on the entity’s tax return on line 1 and any business, trade, or DBA name on line 2.

d. **Other entities.** Enter your name as shown on required U.S. federal tax documents on line 1. This name should match the name shown on the charter or other legal document creating the entity. You may enter any business, trade, or DBA name on line 2.

e. **Disregarded entity.** For U.S. federal tax purposes, an entity that is disregarded as an entity separate from its owner is treated as a “disregarded entity.” See Regulations section 301.7701-2(c)(2)(iii). Enter the owner’s name on line 1. The name of the entity entered on line 1 should never be a disregarded entity. The name on line 1 should be the name shown on the income tax return on which the income should be reported. For example, if a foreign LLC that is treated as a disregarded entity for U.S. federal tax purposes has a single owner that is a U.S. person, the U.S. owner’s name is required to be provided on line 1. If the direct owner of the entity is also a disregarded entity, enter the first owner that is not disregarded for federal tax purposes. Enter the disregarded entity’s name on line 2, “Business name/disregarded entity name.” If the owner of the disregarded entity is a foreign person, the owner must complete an appropriate Form W-8 instead of a Form W-9. This is the case even if the foreign person has a U.S. TIN.

Line 2

If you have a business name, trade name, DBA name, or disregarded entity name, you may enter it on line 2.

Line 3

Check the appropriate box on line 3 for the U.S. federal tax classification of the person whose name is entered on line 1. Check only one box on line 3.

IF the entity/person on line 1 is a(n) . . .	THEN check the box for . . .
• Corporation	Corporation
• Individual • Sole proprietorship, or • Single-member limited liability company (LLC) owned by an individual and disregarded for U.S. federal tax purposes.	Individual/sole proprietor or single-member LLC
• LLC treated as a partnership for U.S. federal tax purposes, • LLC that has filed Form 8832 or 2553 to be taxed as a corporation, or • LLC that is disregarded as an entity separate from its owner but the owner is another LLC that is not disregarded for U.S. federal tax purposes.	Limited liability company and enter the appropriate tax classification. (P= Partnership; C= C corporation; or S= S corporation)
• Partnership	Partnership
• Trust/estate	Trust/estate

Line 4, Exemptions

If you are exempt from backup withholding and/or FATCA reporting, enter in the appropriate space on line 4 any code(s) that may apply to you.

Exempt payee code.

- Generally, individuals (including sole proprietors) are not exempt from backup withholding.
- Except as provided below, corporations are exempt from backup withholding for certain payments, including interest and dividends.
- Corporations are not exempt from backup withholding for payments made in settlement of payment card or third party network transactions.
- Corporations are not exempt from backup withholding with respect to attorneys’ fees or gross proceeds paid to attorneys, and corporations that provide medical or health care services are not exempt with respect to payments reportable on Form 1099-MISC.

The following codes identify payees that are exempt from backup withholding. Enter the appropriate code in the space in line 4.

- 1—An organization exempt from tax under section 501(a), any IRA, or a custodial account under section 403(b)(7) if the account satisfies the requirements of section 401(f)(2)
- 2—The United States or any of its agencies or instrumentalities
- 3—A state, the District of Columbia, a U.S. commonwealth or possession, or any of their political subdivisions or instrumentalities
- 4—A foreign government or any of its political subdivisions, agencies, or instrumentalities
- 5—A corporation
- 6—A dealer in securities or commodities required to register in the United States, the District of Columbia, or a U.S. commonwealth or possession
- 7—A futures commission merchant registered with the Commodity Futures Trading Commission
- 8—A real estate investment trust
- 9—An entity registered at all times during the tax year under the Investment Company Act of 1940
- 10—A common trust fund operated by a bank under section 584(a)
- 11—A financial institution
- 12—A middleman known in the investment community as a nominee or custodian
- 13—A trust exempt from tax under section 664 or described in section 4947

The following chart shows types of payments that may be exempt from backup withholding. The chart applies to the exempt payees listed above, 1 through 13.

IF the payment is for . . .	THEN the payment is exempt for . . .
Interest and dividend payments	All exempt payees except for 7
Broker transactions	Exempt payees 1 through 4 and 6 through 11 and all C corporations. S corporations must not enter an exempt payee code because they are exempt only for sales of noncovered securities acquired prior to 2012.
Barter exchange transactions and patronage dividends	Exempt payees 1 through 4
Payments over \$600 required to be reported and direct sales over \$5,000 ¹	Generally, exempt payees 1 through 5 ²
Payments made in settlement of payment card or third party network transactions	Exempt payees 1 through 4

¹ See Form 1099-MISC, Miscellaneous Income, and its instructions.

² However, the following payments made to a corporation and reportable on Form 1099-MISC are not exempt from backup withholding: medical and health care payments, attorneys' fees, gross proceeds paid to an attorney reportable under section 6045(f), and payments for services paid by a federal executive agency.

Exemption from FATCA reporting code. The following codes identify payees that are exempt from reporting under FATCA. These codes apply to persons submitting this form for accounts maintained outside of the United States by certain foreign financial institutions. Therefore, if you are only submitting this form for an account you hold in the United States, you may leave this field blank. Consult with the person requesting this form if you are uncertain if the financial institution is subject to these requirements. A requester may indicate that a code is not required by providing you with a Form W-9 with "Not Applicable" (or any similar indication) written or printed on the line for a FATCA exemption code.

- A—An organization exempt from tax under section 501(a) or any individual retirement plan as defined in section 7701(a)(37)
- B—The United States or any of its agencies or instrumentalities
- C—A state, the District of Columbia, a U.S. commonwealth or possession, or any of their political subdivisions or instrumentalities
- D—A corporation the stock of which is regularly traded on one or more established securities markets, as described in Regulations section 1.1472-1(c)(1)(i)
- E—A corporation that is a member of the same expanded affiliated group as a corporation described in Regulations section 1.1472-1(c)(1)(i)
- F—A dealer in securities, commodities, or derivative financial instruments (including notional principal contracts, futures, forwards, and options) that is registered as such under the laws of the United States or any state
- G—A real estate investment trust
- H—A regulated investment company as defined in section 851 or an entity registered at all times during the tax year under the Investment Company Act of 1940
- I—A common trust fund as defined in section 584(a)
- J—A bank as defined in section 581
- K—A broker
- L—A trust exempt from tax under section 664 or described in section 4947(a)(1)

M—A tax exempt trust under a section 403(b) plan or section 457(g) plan

Note: You may wish to consult with the financial institution requesting this form to determine whether the FATCA code and/or exempt payee code should be completed.

Line 5

Enter your address (number, street, and apartment or suite number). This is where the requester of this Form W-9 will mail your information returns. If this address differs from the one the requester already has on file, write NEW at the top. If a new address is provided, there is still a chance the old address will be used until the payor changes your address in their records.

Line 6

Enter your city, state, and ZIP code.

Part I. Taxpayer Identification Number (TIN)

Enter your TIN in the appropriate box. If you are a resident alien and you do not have and are not eligible to get an SSN, your TIN is your IRS individual taxpayer identification number (ITIN). Enter it in the social security number box. If you do not have an ITIN, see *How to get a TIN* below.

If you are a sole proprietor and you have an EIN, you may enter either your SSN or EIN.

If you are a single-member LLC that is disregarded as an entity separate from its owner, enter the owner's SSN (or EIN, if the owner has one). Do not enter the disregarded entity's EIN. If the LLC is classified as a corporation or partnership, enter the entity's EIN.

Note: See *What Name and Number To Give the Requester*, later, for further clarification of name and TIN combinations.

How to get a TIN. If you do not have a TIN, apply for one immediately. To apply for an SSN, get Form SS-5, Application for a Social Security Card, from your local SSA office or get this form online at www.SSA.gov. You may also get this form by calling 1-800-772-1213. Use Form W-7, Application for IRS Individual Taxpayer Identification Number, to apply for an ITIN, or Form SS-4, Application for Employer Identification Number, to apply for an EIN. You can apply for an EIN online by accessing the IRS website at www.irs.gov/Businesses and clicking on Employer Identification Number (EIN) under Starting a Business. Go to www.irs.gov/Forms to view, download, or print Form W-7 and/or Form SS-4. Or, you can go to www.irs.gov/OrderForms to place an order and have Form W-7 and/or SS-4 mailed to you within 10 business days.

If you are asked to complete Form W-9 but do not have a TIN, apply for a TIN and write "Applied For" in the space for the TIN, sign and date the form, and give it to the requester. For interest and dividend payments, and certain payments made with respect to readily tradable instruments, generally you will have 60 days to get a TIN and give it to the requester before you are subject to backup withholding on payments. The 60-day rule does not apply to other types of payments. You will be subject to backup withholding on all such payments until you provide your TIN to the requester.

Note: Entering "Applied For" means that you have already applied for a TIN or that you intend to apply for one soon.

Caution: A disregarded U.S. entity that has a foreign owner must use the appropriate Form W-8.

Part II. Certification

To establish to the withholding agent that you are a U.S. person, or resident alien, sign Form W-9. You may be requested to sign by the withholding agent even if item 1, 4, or 5 below indicates otherwise.

For a joint account, only the person whose TIN is shown in Part I should sign (when required). In the case of a disregarded entity, the person identified on line 1 must sign. Exempt payees, see *Exempt payee code*, earlier.

Signature requirements. Complete the certification as indicated in items 1 through 5 below.

1. Interest, dividend, and barter exchange accounts opened before 1984 and broker accounts considered active during 1983. You must give your correct TIN, but you do not have to sign the certification.

2. Interest, dividend, broker, and barter exchange accounts opened after 1983 and broker accounts considered inactive during 1983. You must sign the certification or backup withholding will apply. If you are subject to backup withholding and you are merely providing your correct TIN to the requester, you must cross out item 2 in the certification before signing the form.

3. Real estate transactions. You must sign the certification. You may cross out item 2 of the certification.

4. Other payments. You must give your correct TIN, but you do not have to sign the certification unless you have been notified that you have previously given an incorrect TIN. "Other payments" include payments made in the course of the requester's trade or business for rents, royalties, goods (other than bills for merchandise), medical and health care services (including payments to corporations), payments to a nonemployee for services, payments made in settlement of payment card and third party network transactions, payments to certain fishing boat crew members and fishermen, and gross proceeds paid to attorneys (including payments to corporations).

5. Mortgage interest paid by you, acquisition or abandonment of secured property, cancellation of debt, qualified tuition program payments (under section 529), ABLE accounts (under section 529A), IRA, Coverdell ESA, Archer MSA or HSA contributions or distributions, and pension distributions. You must give your correct TIN, but you do not have to sign the certification.

What Name and Number To Give the Requester

For this type of account:	Give name and SSN of:
1. Individual	The individual
2. Two or more individuals (joint account) other than an account maintained by an FFI	The actual owner of the account or, if combined funds, the first individual on the account ¹
3. Two or more U.S. persons (joint account maintained by an FFI)	Each holder of the account
4. Custodial account of a minor (Uniform Gift to Minors Act)	The minor ²
5. a. The usual revocable savings trust (grantor is also trustee) b. So-called trust account that is not a legal or valid trust under state law	The grantor-trustee ¹ The actual owner ¹
6. Sole proprietorship or disregarded entity owned by an individual	The owner ³
7. Grantor trust filing under Optional Form 1099 Filing Method 1 (see Regulations section 1.671-4(b)(2)(i)(A))	The grantor ⁴
For this type of account:	Give name and EIN of:
8. Disregarded entity not owned by an individual	The owner
9. A valid trust, estate, or pension trust	Legal entity ⁴
10. Corporation or LLC electing corporate status on Form 8832 or Form 2553	The corporation
11. Association, club, religious, charitable, educational, or other tax-exempt organization	The organization
12. Partnership or multi-member LLC	The partnership
13. A broker or registered nominee	The broker or nominee

For this type of account:	Give name and EIN of:
14. Account with the Department of Agriculture in the name of a public entity (such as a state or local government, school district, or prison) that receives agricultural program payments	The public entity
15. Grantor trust filing under the Form 1041 Filing Method or the Optional Form 1099 Filing Method 2 (see Regulations section 1.671-4(b)(2)(i)(B))	The trust

¹ List first and circle the name of the person whose number you furnish. If only one person on a joint account has an SSN, that person's number must be furnished.

² Circle the minor's name and furnish the minor's SSN.

³ You must show your individual name and you may also enter your business or DBA name on the "Business name/disregarded entity" name line. You may use either your SSN or EIN (if you have one), but the IRS encourages you to use your SSN.

⁴ List first and circle the name of the trust, estate, or pension trust. (Do not furnish the TIN of the personal representative or trustee unless the legal entity itself is not designated in the account title.) Also see *Special rules for partnerships*, earlier.

***Note:** The grantor also must provide a Form W-9 to trustee of trust.

Note: If no name is circled when more than one name is listed, the number will be considered to be that of the first name listed.

Secure Your Tax Records From Identity Theft

Identity theft occurs when someone uses your personal information such as your name, SSN, or other identifying information, without your permission, to commit fraud or other crimes. An identity thief may use your SSN to get a job or may file a tax return using your SSN to receive a refund.

To reduce your risk:

- Protect your SSN,
- Ensure your employer is protecting your SSN, and
- Be careful when choosing a tax preparer.

If your tax records are affected by identity theft and you receive a notice from the IRS, respond right away to the name and phone number printed on the IRS notice or letter.

If your tax records are not currently affected by identity theft but you think you are at risk due to a lost or stolen purse or wallet, questionable credit card activity or credit report, contact the IRS Identity Theft Hotline at 1-800-908-4490 or submit Form 14039.

For more information, see Pub. 5027, Identity Theft Information for Taxpayers.

Victims of identity theft who are experiencing economic harm or a systemic problem, or are seeking help in resolving tax problems that have not been resolved through normal channels, may be eligible for Taxpayer Advocate Service (TAS) assistance. You can reach TAS by calling the TAS toll-free case intake line at 1-877-777-4778 or TTY/TDD 1-800-829-4059.

Protect yourself from suspicious emails or phishing schemes. Phishing is the creation and use of email and websites designed to mimic legitimate business emails and websites. The most common act is sending an email to a user falsely claiming to be an established legitimate enterprise in an attempt to scam the user into surrendering private information that will be used for identity theft.

The IRS does not initiate contacts with taxpayers via emails. Also, the IRS does not request personal detailed information through email or ask taxpayers for the PIN numbers, passwords, or similar secret access information for their credit card, bank, or other financial accounts.

If you receive an unsolicited email claiming to be from the IRS, forward this message to phishing@irs.gov. You may also report misuse of the IRS name, logo, or other IRS property to the Treasury Inspector General for Tax Administration (TIGTA) at 1-800-366-4484. You can forward suspicious emails to the Federal Trade Commission at spam@uce.gov or report them at www.ftc.gov/complaint. You can contact the FTC at www.ftc.gov/idtheft or 877-IDTHEFT (877-438-4338). If you have been the victim of identity theft, see www.IdentityTheft.gov and Pub. 5027.

Visit www.irs.gov/IdentityTheft to learn more about identity theft and how to reduce your risk.

Privacy Act Notice

Section 6109 of the Internal Revenue Code requires you to provide your correct TIN to persons (including federal agencies) who are required to file information returns with the IRS to report interest, dividends, or certain other income paid to you; mortgage interest you paid; the acquisition or abandonment of secured property; the cancellation of debt; or contributions you made to an IRA, Archer MSA, or HSA. The person collecting this form uses the information on the form to file information returns with the IRS, reporting the above information. Routine uses of this information include giving it to the Department of Justice for civil and criminal litigation and to cities, states, the District of Columbia, and U.S. commonwealths and possessions for use in administering their laws. The information also may be disclosed to other countries under a treaty, to federal and state agencies to enforce civil and criminal laws, or to federal law enforcement and intelligence agencies to combat terrorism. You must provide your TIN whether or not you are required to file a tax return. Under section 3406, payers must generally withhold a percentage of taxable interest, dividend, and certain other payments to a payee who does not give a TIN to the payer. Certain penalties may also apply for providing false or fraudulent information.

CONFLICT OF INTEREST QUESTIONNAIRE

FORM CIQ

For vendor or other person doing business with local governmental entity

This questionnaire reflects changes made to the law by H.B. 1491, 80th Leg., Regular Session.

This questionnaire is being filed in accordance with Chapter 176, Local Government Code by a person who has a business relationship as defined by Section 176.001 (1-a) with a local governmental entity and the person meets requirements under Section 176.006(a).

By law this questionnaire must be filed with the records administrator of the local governmental entity not later than the 7th business day after the date the person becomes aware of facts that require the statement to be filed. See Section 176.006, Local Government Code.

A person commits an offense if the person knowingly violates Section 176.006, Local Government Code. An offense under this section is a Class C misdemeanor.

OFFICE USE ONLY

Date Received

1 Name of person who has a business relationship with local governmental entity.

2 Check this box if you are filing an update to a previously filed questionnaire.

(The law requires that you file an updated completed questionnaire with the appropriate filing authority not later than the 7th business day after the date the originally filed questionnaire becomes incomplete or inaccurate.)

3 Name of local government officer with whom filer has employment or business relationship.

Name of Officer

This section (item 3 including subparts A, B, C & D) must be completed for each *officer* with whom the filer has an employment or other business relationship as defined by Section 176.001 (1-a), Local Government Code. Attach additional pages to this Form CIQ as necessary.

A. Is the local government officer named in this section receiving or likely to receive taxable income, other than investment income, from the filer of the questionnaire?

Yes

NO

B. Is the filer of the questionnaire receiving or likely to receive taxable income, other than investment income, from or at the direction of the local government *officer* named in this section AND the taxable income is not received from the local governmental entity?

Yes

NO

C. Is the filer of this questionnaire employed by a corporation or other business entity with respect to which the local government officer serves as an *officer* or director, or holds an ownership of 10 percent or more?

Yes

NO

D. Describe each employment or business relationship with the local government *officer* named in this section.

4

Signature of person doing business with the governmental entity

Date

Galveston County Mental Health Court Reno

Budget Pricing

September 14, 2021

GSF

3,000

Level 6

CSI Div.	Description	Quantity	Unit	Unit Cost	Cost	Div Totals	\$ / Gross SF	Comments
TYPICAL FLOOR BUILDOUT								
1	Project General Conditions	8 weeks		\$ 4,500.00	\$ 36,000	\$ 36,000	\$12.00	
					\$ -		\$0.00	
					\$ -		\$0.00	
6	Wood & Plastics					\$ 16,356	\$5.45	
	Millwork	1	SUB	\$ 16,356.00	\$ 16,356		\$5.45	
8	Doors, Frames and Hardware					\$ 24,677	\$8.23	
	Doors, Frames, Hardware	1	Sub	\$ 24,677.00	\$ 24,677		\$8.23	
					\$ -		\$0.00	
8	Glass and Glazing					\$ 3,475	\$1.16	
	Glass	1	Sub	\$ 3,475.00	\$ 3,475		\$1.16	
9	Framing, Drywall and Acoustical					\$ 35,060	\$11.69	
	Framing and Drywall	3,000	SF	\$ 5.50	\$ 16,500		\$5.50	
	Drywall Ceilings	250	SF	\$ 6.00	\$ 1,250		\$0.42	
	Acoustical Ceiling Tile	2,445	SF	\$ 6.00	\$ 14,670		\$4.89	
	Acoustical Ceiling Baffles	65	SF	\$ 48.00	\$ 2,640		\$0.88	
9	Finishes					\$ 70,164	\$23.39	
	Demolition	3,000	SF	\$ 5.25	\$ 15,750		\$5.25	
	Painting & Wall Cover	1	Sub	\$ 15,000.00	\$ 15,000		\$5.00	
	Carpet CT-1	130	SY	\$ 43.00	\$ 5,590		\$1.86	
	Carpet CT-2	77	SY	\$ 43.00	\$ 3,297		\$1.10	
	Carpet CT-3	520	SY	\$ 43.00	\$ 22,360		\$7.45	
	LVT Flooring	370	SF	\$ 5.00	\$ 1,850		\$0.62	
	Rubber Base	810	LF	\$ 2.50	\$ 2,025		\$0.68	
	Tile Backslashes/ Walls	10	SF	\$ 20.00	\$ 200		\$0.07	
	SS-1 Countertops	62	SF	\$ 66.00	\$ 4,092		\$1.36	
10	Specialties					\$ 2,731	\$0.91	
	Toilet Accessories	1	Sub	\$ 2,731.00	\$ 2,731		\$0.91	
					\$ -		\$0.00	
15	Mechanical					\$ 37,650	\$12.55	
	Fire Protection - Modifications	3,000	SF	\$ 3.25	\$ 9,750		\$3.25	
	Plumbing	1	Sub	\$ 7,500.00	\$ 7,500		\$2.50	
	H. V. A. C.	1	Sub	\$ 20,400.00	\$ 20,400		\$6.80	
16	Electrical					\$ 88,600	\$29.53	
	Electrical	1	Sub	\$ 87,100.00	\$ 87,100		\$29.03	
	Fire Alarm	3,000	SF	\$ 0.50	\$ 1,500		\$0.50	
	AV		Excluded		\$ -		\$0.00	
	Voice/Data	-	Excluded	\$ -	\$ -		\$0.00	
	Security	-	Excluded	\$ -	\$ -		\$0.00	
	Miscellaneous					\$ 2,250	\$0.75	
	Final Cleaning	3,000	SF	\$ 0.75	\$ 2,250		\$0.75	
	Subtotal Cost of the Work				\$ 316,963	\$ 316,963	\$105.65	
	Fee			4.00%	12,679		\$4.23	
	Insurance - GL and Umbrella Only			0.55%	1,813		\$0.60	
	Contingency			5.00%	16,482		\$5.49	
	Renovation Tax	Excluded		0.00%	-		\$0.00	
	TOTAL TYPICAL OFFICE LEVELS				\$ 347,936		\$115.98	



GALVESTON COUNTY MENTAL HEALTH COURT RENOVATION

Mental Health Court Renovation Galveston, Texas

Project State Registration #:



ARCHITECTURE
ENGINEERING
INTERIORS
PLANNING

ALEXANDRIA
ATLANTA
AUSTIN
BOCA RATON
CHICAGO
DALLAS
DENVER
HOBOKEN
HOUSTON
LAS VEGAS
LOS ANGELES
SALT LAKE CITY
SAN DIEGO

REGISTERED
ARCHITECT
STATE OF TEXAS
NO. 001718



REGISTERED
PROFESSIONAL
ENGINEER
STATE OF TEXAS
NO. 001718

ARCHITECT



PGAL, INC.
3131 BRIARPARK DR SUITE 200
HOUSTON, TEXAS 77042
T) 713-622-1444

MEP ENGINEERS



INFRASTRUCTURE ASSOCIATES, INC.
6117 RICHMOND AVENUE SUITE 200
HOUSTON, TEXAS 77057
T) 713-622-0120

SHEET INDEX

Sheet	Sheet Name
00	COVER SHEET
01	GENERAL NOTES
02	GENERAL REQUIREMENTS
03	FOUNDATION
04	CONCRETE
05	STEEL
06	MECHANICAL
07	ELECTRICAL
08	PLUMBING
09	MECHANICAL, ELECTRICAL, PLUMBING (MEP)
10	MECHANICAL, ELECTRICAL, PLUMBING (MEP) - CONTINUED
11	MECHANICAL, ELECTRICAL, PLUMBING (MEP) - CONTINUED
12	MECHANICAL, ELECTRICAL, PLUMBING (MEP) - CONTINUED
13	MECHANICAL, ELECTRICAL, PLUMBING (MEP) - CONTINUED
14	MECHANICAL, ELECTRICAL, PLUMBING (MEP) - CONTINUED
15	MECHANICAL, ELECTRICAL, PLUMBING (MEP) - CONTINUED
16	MECHANICAL, ELECTRICAL, PLUMBING (MEP) - CONTINUED
17	MECHANICAL, ELECTRICAL, PLUMBING (MEP) - CONTINUED
18	MECHANICAL, ELECTRICAL, PLUMBING (MEP) - CONTINUED
19	MECHANICAL, ELECTRICAL, PLUMBING (MEP) - CONTINUED
20	MECHANICAL, ELECTRICAL, PLUMBING (MEP) - CONTINUED
21	MECHANICAL, ELECTRICAL, PLUMBING (MEP) - CONTINUED
22	MECHANICAL, ELECTRICAL, PLUMBING (MEP) - CONTINUED
23	MECHANICAL, ELECTRICAL, PLUMBING (MEP) - CONTINUED
24	MECHANICAL, ELECTRICAL, PLUMBING (MEP) - CONTINUED
25	MECHANICAL, ELECTRICAL, PLUMBING (MEP) - CONTINUED
26	MECHANICAL, ELECTRICAL, PLUMBING (MEP) - CONTINUED
27	MECHANICAL, ELECTRICAL, PLUMBING (MEP) - CONTINUED
28	MECHANICAL, ELECTRICAL, PLUMBING (MEP) - CONTINUED
29	MECHANICAL, ELECTRICAL, PLUMBING (MEP) - CONTINUED
30	MECHANICAL, ELECTRICAL, PLUMBING (MEP) - CONTINUED
31	MECHANICAL, ELECTRICAL, PLUMBING (MEP) - CONTINUED
32	MECHANICAL, ELECTRICAL, PLUMBING (MEP) - CONTINUED
33	MECHANICAL, ELECTRICAL, PLUMBING (MEP) - CONTINUED
34	MECHANICAL, ELECTRICAL, PLUMBING (MEP) - CONTINUED
35	MECHANICAL, ELECTRICAL, PLUMBING (MEP) - CONTINUED
36	MECHANICAL, ELECTRICAL, PLUMBING (MEP) - CONTINUED
37	MECHANICAL, ELECTRICAL, PLUMBING (MEP) - CONTINUED
38	MECHANICAL, ELECTRICAL, PLUMBING (MEP) - CONTINUED
39	MECHANICAL, ELECTRICAL, PLUMBING (MEP) - CONTINUED
40	MECHANICAL, ELECTRICAL, PLUMBING (MEP) - CONTINUED
41	MECHANICAL, ELECTRICAL, PLUMBING (MEP) - CONTINUED
42	MECHANICAL, ELECTRICAL, PLUMBING (MEP) - CONTINUED
43	MECHANICAL, ELECTRICAL, PLUMBING (MEP) - CONTINUED
44	MECHANICAL, ELECTRICAL, PLUMBING (MEP) - CONTINUED
45	MECHANICAL, ELECTRICAL, PLUMBING (MEP) - CONTINUED
46	MECHANICAL, ELECTRICAL, PLUMBING (MEP) - CONTINUED
47	MECHANICAL, ELECTRICAL, PLUMBING (MEP) - CONTINUED
48	MECHANICAL, ELECTRICAL, PLUMBING (MEP) - CONTINUED
49	MECHANICAL, ELECTRICAL, PLUMBING (MEP) - CONTINUED
50	MECHANICAL, ELECTRICAL, PLUMBING (MEP) - CONTINUED
51	MECHANICAL, ELECTRICAL, PLUMBING (MEP) - CONTINUED
52	MECHANICAL, ELECTRICAL, PLUMBING (MEP) - CONTINUED
53	MECHANICAL, ELECTRICAL, PLUMBING (MEP) - CONTINUED
54	MECHANICAL, ELECTRICAL, PLUMBING (MEP) - CONTINUED
55	MECHANICAL, ELECTRICAL, PLUMBING (MEP) - CONTINUED
56	MECHANICAL, ELECTRICAL, PLUMBING (MEP) - CONTINUED
57	MECHANICAL, ELECTRICAL, PLUMBING (MEP) - CONTINUED
58	MECHANICAL, ELECTRICAL, PLUMBING (MEP) - CONTINUED
59	MECHANICAL, ELECTRICAL, PLUMBING (MEP) - CONTINUED
60	MECHANICAL, ELECTRICAL, PLUMBING (MEP) - CONTINUED
61	MECHANICAL, ELECTRICAL, PLUMBING (MEP) - CONTINUED
62	MECHANICAL, ELECTRICAL, PLUMBING (MEP) - CONTINUED
63	MECHANICAL, ELECTRICAL, PLUMBING (MEP) - CONTINUED
64	MECHANICAL, ELECTRICAL, PLUMBING (MEP) - CONTINUED
65	MECHANICAL, ELECTRICAL, PLUMBING (MEP) - CONTINUED
66	MECHANICAL, ELECTRICAL, PLUMBING (MEP) - CONTINUED
67	MECHANICAL, ELECTRICAL, PLUMBING (MEP) - CONTINUED
68	MECHANICAL, ELECTRICAL, PLUMBING (MEP) - CONTINUED
69	MECHANICAL, ELECTRICAL, PLUMBING (MEP) - CONTINUED
70	MECHANICAL, ELECTRICAL, PLUMBING (MEP) - CONTINUED
71	MECHANICAL, ELECTRICAL, PLUMBING (MEP) - CONTINUED
72	MECHANICAL, ELECTRICAL, PLUMBING (MEP) - CONTINUED
73	MECHANICAL, ELECTRICAL, PLUMBING (MEP) - CONTINUED
74	MECHANICAL, ELECTRICAL, PLUMBING (MEP) - CONTINUED
75	MECHANICAL, ELECTRICAL, PLUMBING (MEP) - CONTINUED
76	MECHANICAL, ELECTRICAL, PLUMBING (MEP) - CONTINUED
77	MECHANICAL, ELECTRICAL, PLUMBING (MEP) - CONTINUED
78	MECHANICAL, ELECTRICAL, PLUMBING (MEP) - CONTINUED
79	MECHANICAL, ELECTRICAL, PLUMBING (MEP) - CONTINUED
80	MECHANICAL, ELECTRICAL, PLUMBING (MEP) - CONTINUED
81	MECHANICAL, ELECTRICAL, PLUMBING (MEP) - CONTINUED
82	MECHANICAL, ELECTRICAL, PLUMBING (MEP) - CONTINUED
83	MECHANICAL, ELECTRICAL, PLUMBING (MEP) - CONTINUED
84	MECHANICAL, ELECTRICAL, PLUMBING (MEP) - CONTINUED
85	MECHANICAL, ELECTRICAL, PLUMBING (MEP) - CONTINUED
86	MECHANICAL, ELECTRICAL, PLUMBING (MEP) - CONTINUED
87	MECHANICAL, ELECTRICAL, PLUMBING (MEP) - CONTINUED
88	MECHANICAL, ELECTRICAL, PLUMBING (MEP) - CONTINUED
89	MECHANICAL, ELECTRICAL, PLUMBING (MEP) - CONTINUED
90	MECHANICAL, ELECTRICAL, PLUMBING (MEP) - CONTINUED
91	MECHANICAL, ELECTRICAL, PLUMBING (MEP) - CONTINUED
92	MECHANICAL, ELECTRICAL, PLUMBING (MEP) - CONTINUED
93	MECHANICAL, ELECTRICAL, PLUMBING (MEP) - CONTINUED
94	MECHANICAL, ELECTRICAL, PLUMBING (MEP) - CONTINUED
95	MECHANICAL, ELECTRICAL, PLUMBING (MEP) - CONTINUED
96	MECHANICAL, ELECTRICAL, PLUMBING (MEP) - CONTINUED
97	MECHANICAL, ELECTRICAL, PLUMBING (MEP) - CONTINUED
98	MECHANICAL, ELECTRICAL, PLUMBING (MEP) - CONTINUED
99	MECHANICAL, ELECTRICAL, PLUMBING (MEP) - CONTINUED
100	MECHANICAL, ELECTRICAL, PLUMBING (MEP) - CONTINUED

PROJECT NUMBER
1005437.00

SHEET TITLE
COVER SHEET

SHEET NUMBER
G0.00

09/27/2021
CONSTRUCTION DOCUMENTS
FOR BID & PERMIT



Manuel Health Court



PGAL, Inc.
3001 S. Loop West, Suite 200
Houston, TX 77042
P: 713.522.1444
www.pgal.com



DAVID M. HESTER
Professional Engineer
No. 1005437.00

PROJECT NAME: GALVESTON COUNTY MENTAL HEALTH COURT RENOVATION
PROJECT LOCATION: Galveston, Texas
PROJECT NUMBER: 1005437.00
SHEET TITLE: GENERAL PROJECT INFORMATION
SHEET NUMBER: G.0.02

GENERAL PROJECT NOTES

- 1. The Contractor shall be responsible for obtaining all necessary permits from the City of Galveston and the State of Texas.
2. The Contractor shall be responsible for obtaining all necessary permits from the City of Galveston and the State of Texas.
3. The Contractor shall be responsible for obtaining all necessary permits from the City of Galveston and the State of Texas.
4. The Contractor shall be responsible for obtaining all necessary permits from the City of Galveston and the State of Texas.
5. The Contractor shall be responsible for obtaining all necessary permits from the City of Galveston and the State of Texas.
6. The Contractor shall be responsible for obtaining all necessary permits from the City of Galveston and the State of Texas.
7. The Contractor shall be responsible for obtaining all necessary permits from the City of Galveston and the State of Texas.
8. The Contractor shall be responsible for obtaining all necessary permits from the City of Galveston and the State of Texas.
9. The Contractor shall be responsible for obtaining all necessary permits from the City of Galveston and the State of Texas.
10. The Contractor shall be responsible for obtaining all necessary permits from the City of Galveston and the State of Texas.
11. The Contractor shall be responsible for obtaining all necessary permits from the City of Galveston and the State of Texas.
12. The Contractor shall be responsible for obtaining all necessary permits from the City of Galveston and the State of Texas.
13. The Contractor shall be responsible for obtaining all necessary permits from the City of Galveston and the State of Texas.
14. The Contractor shall be responsible for obtaining all necessary permits from the City of Galveston and the State of Texas.
15. The Contractor shall be responsible for obtaining all necessary permits from the City of Galveston and the State of Texas.
16. The Contractor shall be responsible for obtaining all necessary permits from the City of Galveston and the State of Texas.
17. The Contractor shall be responsible for obtaining all necessary permits from the City of Galveston and the State of Texas.
18. The Contractor shall be responsible for obtaining all necessary permits from the City of Galveston and the State of Texas.
19. The Contractor shall be responsible for obtaining all necessary permits from the City of Galveston and the State of Texas.
20. The Contractor shall be responsible for obtaining all necessary permits from the City of Galveston and the State of Texas.
21. The Contractor shall be responsible for obtaining all necessary permits from the City of Galveston and the State of Texas.
22. The Contractor shall be responsible for obtaining all necessary permits from the City of Galveston and the State of Texas.
23. The Contractor shall be responsible for obtaining all necessary permits from the City of Galveston and the State of Texas.
24. The Contractor shall be responsible for obtaining all necessary permits from the City of Galveston and the State of Texas.
25. The Contractor shall be responsible for obtaining all necessary permits from the City of Galveston and the State of Texas.
26. The Contractor shall be responsible for obtaining all necessary permits from the City of Galveston and the State of Texas.
27. The Contractor shall be responsible for obtaining all necessary permits from the City of Galveston and the State of Texas.
28. The Contractor shall be responsible for obtaining all necessary permits from the City of Galveston and the State of Texas.
29. The Contractor shall be responsible for obtaining all necessary permits from the City of Galveston and the State of Texas.
30. The Contractor shall be responsible for obtaining all necessary permits from the City of Galveston and the State of Texas.

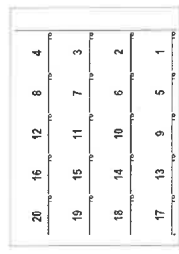

THESE TUBS SHALL BE AVAILABLE FOR EACH SHEET AND BE USED FOR ALL DETAILS. DETAILS WILL BE DRAWN ON ONE OR MULTIPLE MODULES.

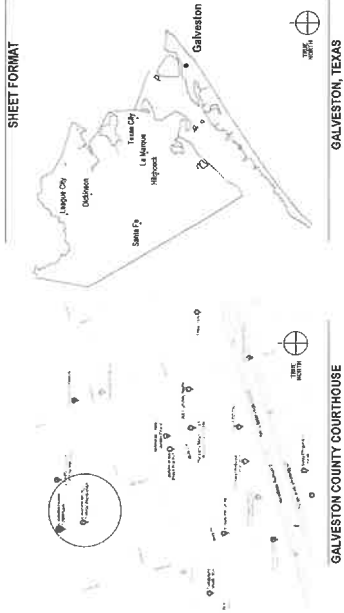

PROJECT GRAPHIC STANDARDS

PROJECT SYMBOLS: Includes symbols for structural elements like columns, beams, walls, and doors. Includes material symbols for concrete, steel, and masonry. Includes abbreviations for various materials and construction details.

ABBREVIATIONS

Table with columns for Abbreviation and Description. Lists various construction materials and components such as CONCRETE, STEEL, MASONRY, and FINISHES.



PGAL Inc.
 3133 Sargent Dr.
 Houston, TX 77042
 P 713 822 4444
 www.pgal.com

CLIENT: METRO HEALTH COURT
ARCHITECT: METRO HEALTH COURT
REGISTERED PROFESSIONAL ENGINEER: PGAL INC. (No. 10173)
REGISTERED PROFESSIONAL ARCHITECT: PGAL INC. (No. 10173)
REGISTERED PROFESSIONAL INTERIOR DESIGNER: PGAL INC. (No. 10173)

MEANS OF EGRESS

OCCUPANCY LOAD
 OCCUPANCY LOAD ALLOWED BY OCCUPANCY

Room Name	Occupancy	Occupancy Load	Comment
101	Office	100 SF	
102	Office	100 SF	
103	Office	100 SF	
104	Office	100 SF	
105	Office	100 SF	
106	Office	100 SF	
107	Office	100 SF	
108	Office	100 SF	
109	Office	100 SF	
110	Office	100 SF	
111	Office	100 SF	
112	Office	100 SF	
113	Office	100 SF	
114	Office	100 SF	
115	Office	100 SF	
116	Office	100 SF	
117	Office	100 SF	
118	Office	100 SF	
119	Office	100 SF	
120	Office	100 SF	
121	Office	100 SF	
122	Office	100 SF	
123	Office	100 SF	
124	Office	100 SF	
125	Office	100 SF	
126	Office	100 SF	
127	Office	100 SF	
128	Office	100 SF	
129	Office	100 SF	
130	Office	100 SF	
131	Office	100 SF	
132	Office	100 SF	
133	Office	100 SF	
134	Office	100 SF	
135	Office	100 SF	
136	Office	100 SF	
137	Office	100 SF	
138	Office	100 SF	
139	Office	100 SF	
140	Office	100 SF	
141	Office	100 SF	
142	Office	100 SF	
143	Office	100 SF	
144	Office	100 SF	
145	Office	100 SF	
146	Office	100 SF	
147	Office	100 SF	
148	Office	100 SF	
149	Office	100 SF	
150	Office	100 SF	

OCCUPANT LOAD CALCULATION

Room Name	Area (SF)	Occupancy	Occupant Load
101	100	100 SF	1
102	100	100 SF	1
103	100	100 SF	1
104	100	100 SF	1
105	100	100 SF	1
106	100	100 SF	1
107	100	100 SF	1
108	100	100 SF	1
109	100	100 SF	1
110	100	100 SF	1
111	100	100 SF	1
112	100	100 SF	1
113	100	100 SF	1
114	100	100 SF	1
115	100	100 SF	1
116	100	100 SF	1
117	100	100 SF	1
118	100	100 SF	1
119	100	100 SF	1
120	100	100 SF	1
121	100	100 SF	1
122	100	100 SF	1
123	100	100 SF	1
124	100	100 SF	1
125	100	100 SF	1
126	100	100 SF	1
127	100	100 SF	1
128	100	100 SF	1
129	100	100 SF	1
130	100	100 SF	1
131	100	100 SF	1
132	100	100 SF	1
133	100	100 SF	1
134	100	100 SF	1
135	100	100 SF	1
136	100	100 SF	1
137	100	100 SF	1
138	100	100 SF	1
139	100	100 SF	1
140	100	100 SF	1
141	100	100 SF	1
142	100	100 SF	1
143	100	100 SF	1
144	100	100 SF	1
145	100	100 SF	1
146	100	100 SF	1
147	100	100 SF	1
148	100	100 SF	1
149	100	100 SF	1
150	100	100 SF	1

MINIMUM NUMBER OF EXITS PER OCCUPANT LOAD (IBC 1021)

GROUP: 1
 OCCUPANCY: 100 SF
 EXITS: 2

MINIMUM NUMBER OF EXITS PER OCCUPANT LOAD (IBC 1021)

GROUP: 1
 OCCUPANCY: 100 SF
 EXITS: 2

APPLICABLE CODES & REGULATIONS

2015 INTERNATIONAL BUILDING CODE (IBC)
 2015 INTERNATIONAL FIRE CODE (IFC)
 2015 INTERNATIONAL MECHANICAL AND PLUMBING CODE (IMC)
 2015 INTERNATIONAL ENERGY CONSERVATION CODE (IECC)
 2015 INTERNATIONAL ELECTRICAL CODE (IEC)
 2015 INTERNATIONAL PLUMBING AND MECHANICAL CODE (IPMC)
 2015 INTERNATIONAL SAFETY CODE (ISCC)
 2015 INTERNATIONAL SCHEDULE OF OCCUPANCY (ISO)
 2015 INTERNATIONAL SIGNAGE CODE (ISC)
 2015 INTERNATIONAL WOOD PRESERVATION CODE (IWPC)
 2015 INTERNATIONAL ZONING AND ORDINANCE CODE (IZOC)

PROJECT DESCRIPTION

OWNER: METRO HEALTH COURT
 PROJECT: METRO HEALTH COURT
 ADDRESS: 3133 SARGENT DR., HOUSTON, TX 77042
 ARCHITECT: METRO HEALTH COURT
 REGISTERED PROFESSIONAL ARCHITECT: PGAL INC. (No. 10173)

OCCUPANCY, CONSTRUCTION TYPE, AND AREA

OCCUPANCY TYPE: 100 SF
 CONSTRUCTION TYPE: 100 SF
 AREA: 100 SF

FIRE-RESISTANCE RATED CONSTRUCTION

FIRE-RESISTANCE RATING: 100 SF
 CONSTRUCTION TYPE: 100 SF
 AREA: 100 SF

FIRE-RESISTANCE RATED CONSTRUCTION

FIRE PROTECTION SYSTEMS (IBC SECTION 900)
 AUTOMATIC FIRE EXTINGUISHING SYSTEMS (IBC SECTION 903)
 PORTABLE FIRE EXTINGUISHERS (IBC SECTION 909)
 FIRE ALARM AND DETECTION SYSTEMS (IBC SECTION 907)

PLUMBING FIXTURES

PLUMBING FIXTURE COUNT (IBC TABLE 3002.1)
 PLUMBING FIXTURES: 100 SF
 AREA: 100 SF

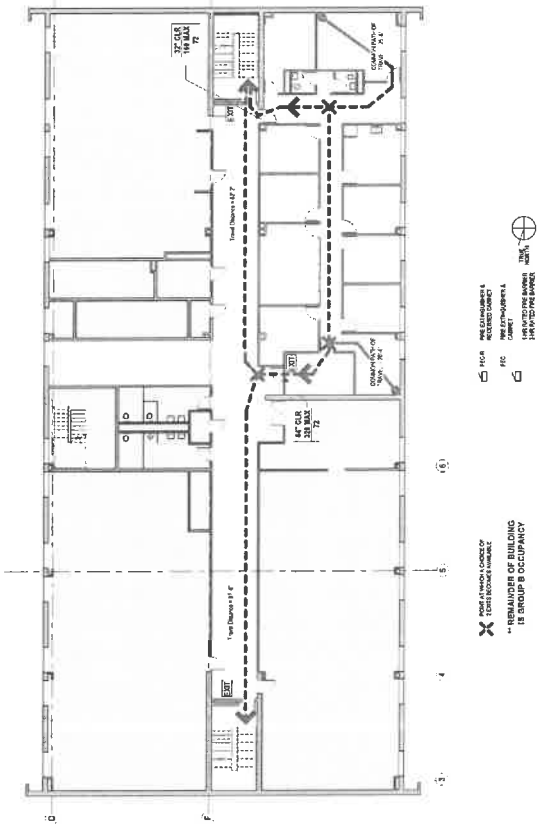

MEANS OF EGRESS

MINIMUM NUMBER OF EXITS PER OCCUPANT LOAD (IBC 1021)

GROUP: 1
 OCCUPANCY: 100 SF
 EXITS: 2

MINIMUM NUMBER OF EXITS PER OCCUPANT LOAD (IBC 1021)

GROUP: 1
 OCCUPANCY: 100 SF
 EXITS: 2

NOTE: NOT ALL DETAILS OR CONDITIONS SHOWN ON THIS SHEET WILL BE USED

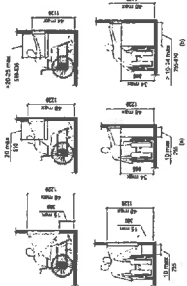

306 Unobstructed Forward Reach

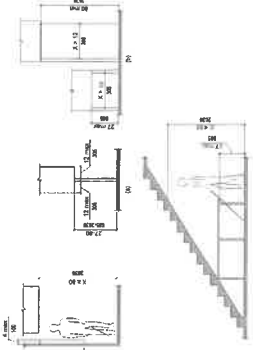

307 Limbs of Protruding Objects

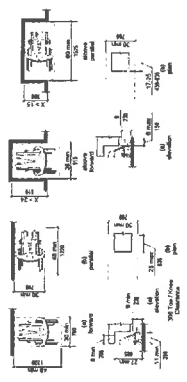

305.3 Clear Floor or Ground Space

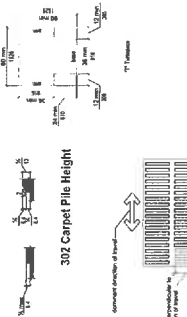

302.3 Elongated Openings in Floor or Ground Surfaces

CHAPTER 3: BUILDING BLOCKS

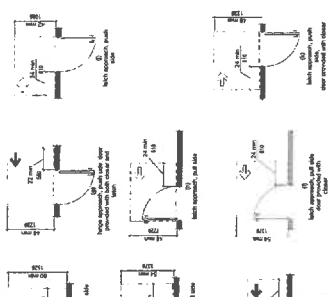

404 Doors, Doorways, and Gates

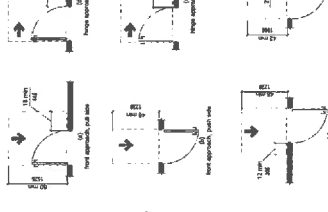

404.2.1.2 Manoeuvring Clearance at Sliding and Folding Doors

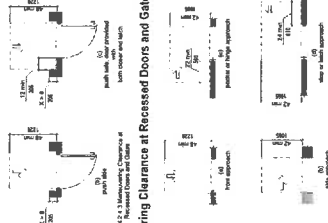

404.2.4.3 Manoeuvring Clearance at Recessed Doors and Gates

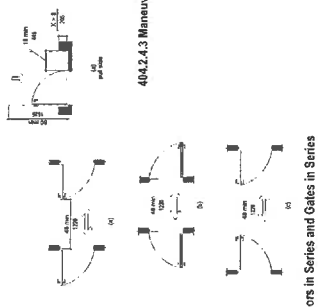

404.2.6 Doors in Series and Gates in Series

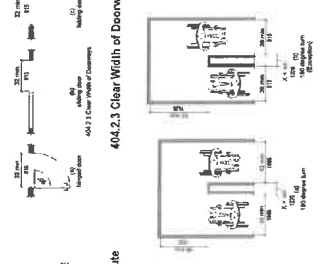

403.5.1 Clear Width of an Accessible Route

404.2.3 Clear Width of Doorways



403.5.2 Clear Width at Turn

CHAPTER 4: ACCESSIBLE ROUTES

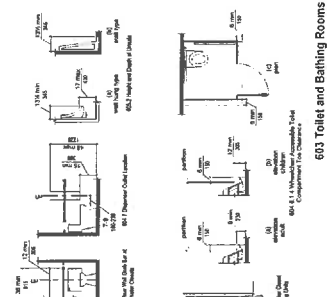

603 Toilet and Bathing Rooms

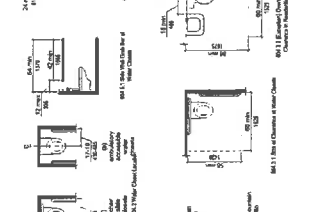

608 Showers

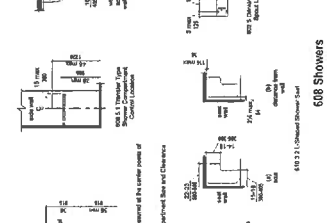

609 Spacing of Grab Bars

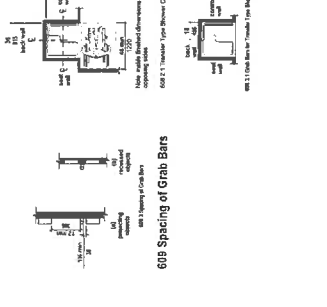

505.4 Handrail Height

505.5 Handrail Clearance

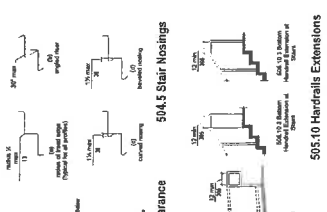

504.5 Stair Nosing

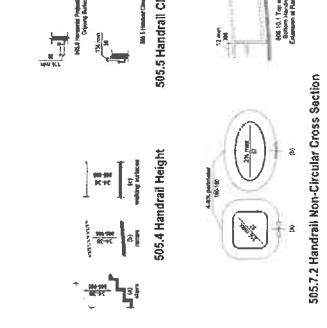

505.7.2 Handrail Non-Circular Cross Section

505.10 Handrails Extensions

CHAPTER 5: GENERAL SITE AND BUILDING ELEMENTS



Client: Mental Health Court



PGAL, Inc. 3131 Baymark Dr. Houston, TX 77042 P 713 822 1444 www.pgal.com

CONTRACT NO. 0000000000

REGISTERED ARCHITECT



DR. JAMES M. ... ARCHITECT

NOTE: NOT ALL DETAILS OR CONDITIONS SHOWN ON THIS SHEET WILL BE USED

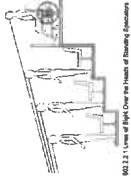

802.1.1 Lines of Sight Over the Heads of Seated Spectators

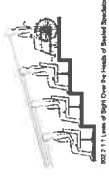

802.1.2 Lines of Sight Over the Heads of Seated Spectators



802.2.1 Lines of Sight Over the Heads of Seated Spectators

Width of Wheelchair Spaces in Assembly Areas

TYPICAL INSTALLATION HEIGHTS

Lines of Sight Over the Heads of Seated Spectators

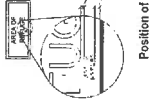

Position of Braille

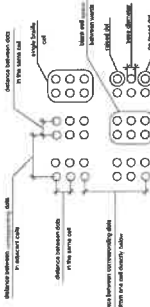

Braille Measurement



Pictogram Field



Parallel Approach to Telephone

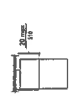

Forward Approach to Telephone



803.2.2.1 International Symbol of Accessibility



803.2.2.2 International TTY Symbol



803.2.2.4 International Symbol of Access with Telephone



803.2.2.3 International TTY Symbol

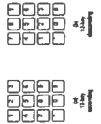

Numeric Key Layout



Height of Raised Characters

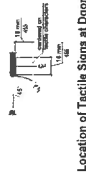

Location of Tactile Signs at Doors

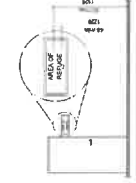

Height of Tactile Characters Above Floor or Ground

Size and Spacing of Truncated Domes

CHAPTER 7: COMMUNICATION ELEMENTS AND FEATURES

PROJECT NAME: GUNTERSON GUESTION CENTER MENTAL HEALTH COURT RENOVATION PROJECT LOCATION: GUNTERSON, TEXAS PROJECT NUMBER: 1005437.00 SHEET TITLE: ADA STANDARDS SHEET NUMBER: G0.12

Graphic Convention for Figures table with columns: Symbol, Description, Notes

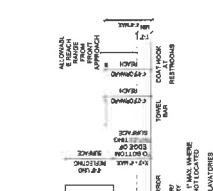

Accessories Mounting Heights

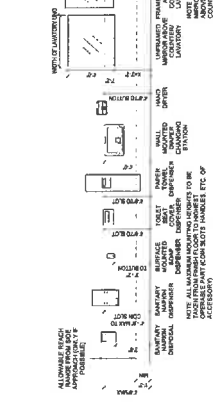

Standard Mounting Heights

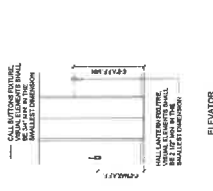

Elevator Mounting Heights

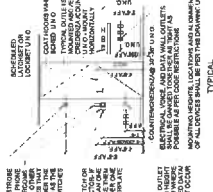

FIRE ALARM PROTECTION

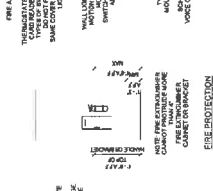

FIRE PROTECTION

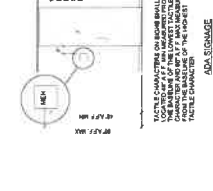

ADA STORAGE

TYPICAL INSTALLATION HEIGHTS

G0.12

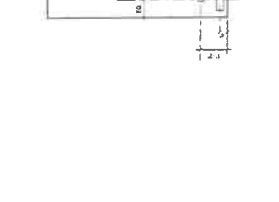
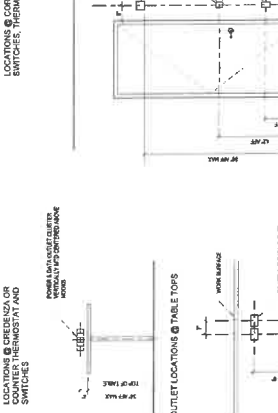
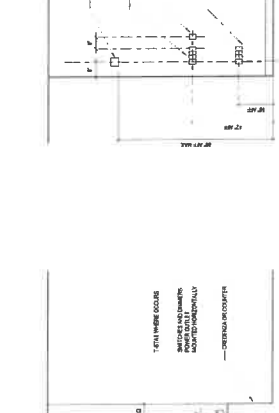
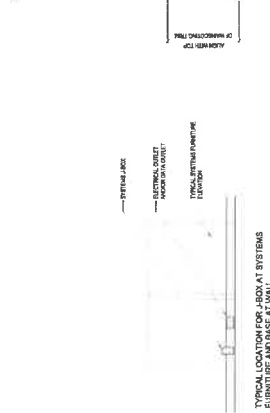
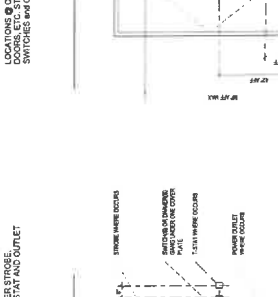
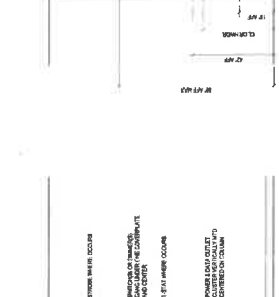
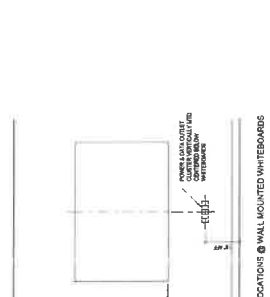
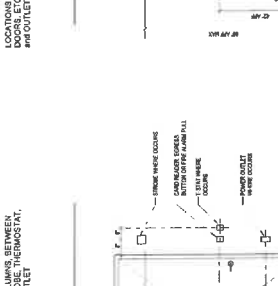
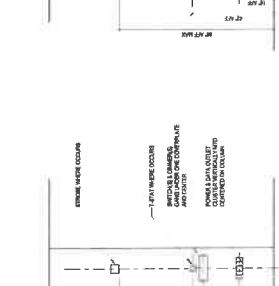
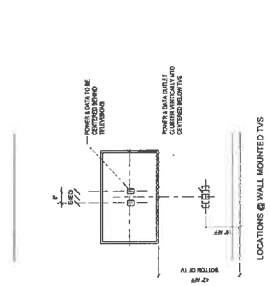
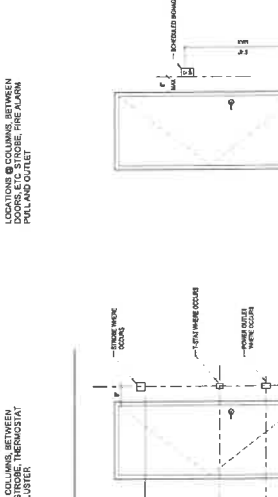
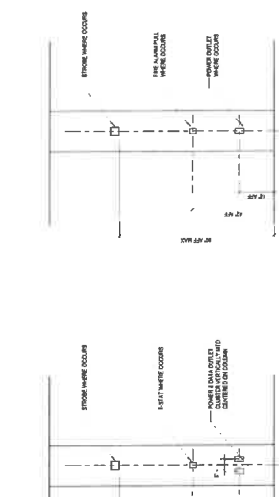
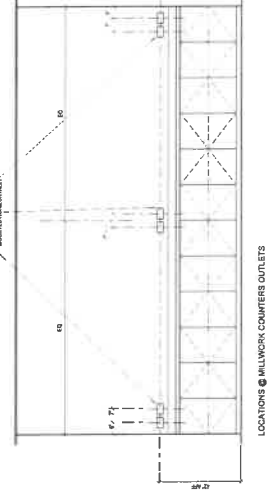
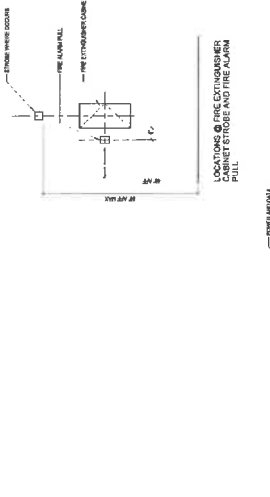

SCALE: 1/8" = 1'-0"
 PARTITION LEGEND
 PARTITION TYPE 1: 1/2" GYPSUM BOARD ON 2x4 STUDS
 PARTITION TYPE 2: 1/2" GYPSUM BOARD ON 2x4 STUDS WITH 1/2" FIBERGLASS INSULATION
 PARTITION TYPE 3: 1/2" GYPSUM BOARD ON 2x4 STUDS WITH 1/2" FIBERGLASS INSULATION AND 1/2" GYPSUM BOARD ON OTHER SIDE
 PARTITION TYPE 4: 1/2" GYPSUM BOARD ON 2x4 STUDS WITH 1/2" FIBERGLASS INSULATION AND 1/2" GYPSUM BOARD ON OTHER SIDE WITH 1/2" GYPSUM BOARD ON TOP AND BOTTOM SURFACES

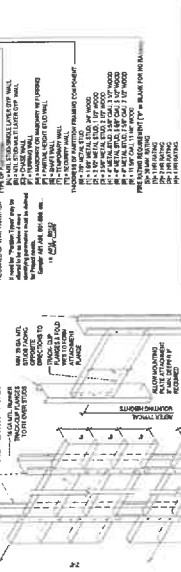

GENERAL NOTES
 1. ALL GENERAL NOTES APPLY TO ALL PARTITION TYPES UNLESS SPECIFICALLY NOTED OTHERWISE.
 2. PARTITION TYPES 2, 3, AND 4 SHALL BE CONSIDERED AS PARTITION TYPES 1 UNLESS SPECIFICALLY NOTED OTHERWISE.
 3. PARTITION TYPES 2, 3, AND 4 SHALL BE CONSIDERED AS PARTITION TYPES 1 UNLESS SPECIFICALLY NOTED OTHERWISE.
 4. PARTITION TYPES 2, 3, AND 4 SHALL BE CONSIDERED AS PARTITION TYPES 1 UNLESS SPECIFICALLY NOTED OTHERWISE.
 5. PARTITION TYPES 2, 3, AND 4 SHALL BE CONSIDERED AS PARTITION TYPES 1 UNLESS SPECIFICALLY NOTED OTHERWISE.
 6. PARTITION TYPES 2, 3, AND 4 SHALL BE CONSIDERED AS PARTITION TYPES 1 UNLESS SPECIFICALLY NOTED OTHERWISE.
 7. PARTITION TYPES 2, 3, AND 4 SHALL BE CONSIDERED AS PARTITION TYPES 1 UNLESS SPECIFICALLY NOTED OTHERWISE.
 8. PARTITION TYPES 2, 3, AND 4 SHALL BE CONSIDERED AS PARTITION TYPES 1 UNLESS SPECIFICALLY NOTED OTHERWISE.
 9. PARTITION TYPES 2, 3, AND 4 SHALL BE CONSIDERED AS PARTITION TYPES 1 UNLESS SPECIFICALLY NOTED OTHERWISE.
 10. PARTITION TYPES 2, 3, AND 4 SHALL BE CONSIDERED AS PARTITION TYPES 1 UNLESS SPECIFICALLY NOTED OTHERWISE.

IN-WALL BRACING
 TYPE A
 TYPE B
 TYPE C



LIMITING HEIGHT NOTES
 1. PARTITION HEIGHTS SHALL BE LIMITED TO 10'-0" UNLESS OTHERWISE SPECIFIED.
 2. PARTITION HEIGHTS SHALL BE LIMITED TO 10'-0" UNLESS OTHERWISE SPECIFIED.
 3. PARTITION HEIGHTS SHALL BE LIMITED TO 10'-0" UNLESS OTHERWISE SPECIFIED.
 4. PARTITION HEIGHTS SHALL BE LIMITED TO 10'-0" UNLESS OTHERWISE SPECIFIED.
 5. PARTITION HEIGHTS SHALL BE LIMITED TO 10'-0" UNLESS OTHERWISE SPECIFIED.

COLD FORMED FRAMING NOTES
 1. PARTITION FRAMING SHALL BE CONSTRUCTED IN ACCORDANCE WITH THE FOLLOWING NOTES:
 2. PARTITION FRAMING SHALL BE CONSTRUCTED IN ACCORDANCE WITH THE FOLLOWING NOTES:
 3. PARTITION FRAMING SHALL BE CONSTRUCTED IN ACCORDANCE WITH THE FOLLOWING NOTES:
 4. PARTITION FRAMING SHALL BE CONSTRUCTED IN ACCORDANCE WITH THE FOLLOWING NOTES:
 5. PARTITION FRAMING SHALL BE CONSTRUCTED IN ACCORDANCE WITH THE FOLLOWING NOTES.



DUCT PENETRATIONS
 TYPE A
 TYPE B
 TYPE C



PARTITION AT MILLION DETAILS
 TYPE A
 TYPE B
 TYPE C



ACoustICAL NOTES
 1. PARTITION TYPES 2, 3, AND 4 SHALL BE CONSIDERED AS PARTITION TYPES 1 UNLESS SPECIFICALLY NOTED OTHERWISE.
 2. PARTITION TYPES 2, 3, AND 4 SHALL BE CONSIDERED AS PARTITION TYPES 1 UNLESS SPECIFICALLY NOTED OTHERWISE.
 3. PARTITION TYPES 2, 3, AND 4 SHALL BE CONSIDERED AS PARTITION TYPES 1 UNLESS SPECIFICALLY NOTED OTHERWISE.
 4. PARTITION TYPES 2, 3, AND 4 SHALL BE CONSIDERED AS PARTITION TYPES 1 UNLESS SPECIFICALLY NOTED OTHERWISE.
 5. PARTITION TYPES 2, 3, AND 4 SHALL BE CONSIDERED AS PARTITION TYPES 1 UNLESS SPECIFICALLY NOTED OTHERWISE.

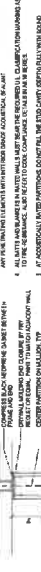

PRECASTING NOTES
 1. PARTITION TYPES 2, 3, AND 4 SHALL BE CONSIDERED AS PARTITION TYPES 1 UNLESS SPECIFICALLY NOTED OTHERWISE.
 2. PARTITION TYPES 2, 3, AND 4 SHALL BE CONSIDERED AS PARTITION TYPES 1 UNLESS SPECIFICALLY NOTED OTHERWISE.
 3. PARTITION TYPES 2, 3, AND 4 SHALL BE CONSIDERED AS PARTITION TYPES 1 UNLESS SPECIFICALLY NOTED OTHERWISE.
 4. PARTITION TYPES 2, 3, AND 4 SHALL BE CONSIDERED AS PARTITION TYPES 1 UNLESS SPECIFICALLY NOTED OTHERWISE.
 5. PARTITION TYPES 2, 3, AND 4 SHALL BE CONSIDERED AS PARTITION TYPES 1 UNLESS SPECIFICALLY NOTED OTHERWISE.



GYPSUM BOARD PARTITION LEGEND
 PARTITION TYPE 1: 1/2" GYPSUM BOARD ON 2x4 STUDS
 PARTITION TYPE 2: 1/2" GYPSUM BOARD ON 2x4 STUDS WITH 1/2" FIBERGLASS INSULATION
 PARTITION TYPE 3: 1/2" GYPSUM BOARD ON 2x4 STUDS WITH 1/2" FIBERGLASS INSULATION AND 1/2" GYPSUM BOARD ON OTHER SIDE
 PARTITION TYPE 4: 1/2" GYPSUM BOARD ON 2x4 STUDS WITH 1/2" FIBERGLASS INSULATION AND 1/2" GYPSUM BOARD ON OTHER SIDE WITH 1/2" GYPSUM BOARD ON TOP AND BOTTOM SURFACES



FIREWALL PARTITION LEGEND
 PARTITION TYPE 1: 1/2" GYPSUM BOARD ON 2x4 STUDS WITH 1/2" FIBERGLASS INSULATION
 PARTITION TYPE 2: 1/2" GYPSUM BOARD ON 2x4 STUDS WITH 1/2" FIBERGLASS INSULATION AND 1/2" GYPSUM BOARD ON OTHER SIDE
 PARTITION TYPE 3: 1/2" GYPSUM BOARD ON 2x4 STUDS WITH 1/2" FIBERGLASS INSULATION AND 1/2" GYPSUM BOARD ON OTHER SIDE WITH 1/2" GYPSUM BOARD ON TOP AND BOTTOM SURFACES

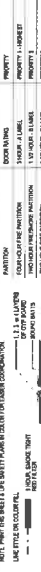

DATE: 02/22/2018 10:54 AM
 FILE: C:\Users\jason\Documents\2018\1054317\1054317.dwg
 DRAWN BY: JASON
 CHECKED BY: JASON

PARTITION TYPES

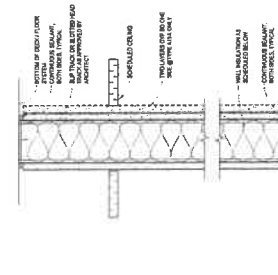

PARTITION TYPE A18, A19A, A19B

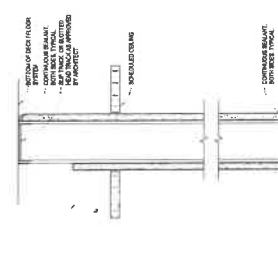

PARTITION TYPE A21

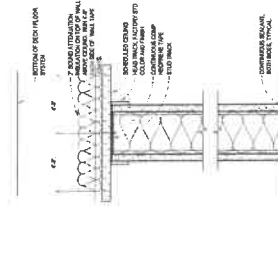

PARTITION TYPE A22



PARTITION TYPE A23

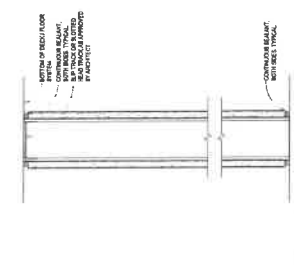

PARTITION TYPE A18

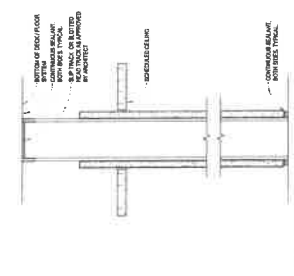

PARTITION TYPE A21

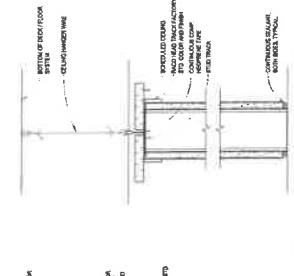

PARTITION TYPE A22

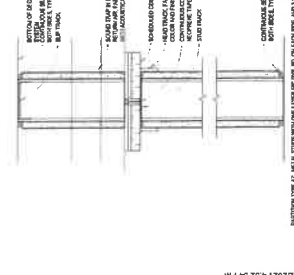

PARTITION TYPE A23



Mental Health Court



PGAL, Inc. 3121 Bellmark Dr. Houston, TX 77042 P. 713 822 4444 F. 713 822 4444 www.pgal.com

CONTRACT NO. 1005437.00

REVISIONS



DAVID W. JETT, P.E. 1005437.00

FRAME CONFIG. LEGEND table with columns for #, #, X, Y, and notes on frame types.

FRAME CONFIG. DESC. table with columns for Description, Material, and Notes.

MATERIALS table with columns for Material, Description, and Notes.

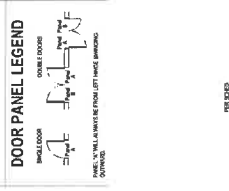

Panel Types - For Reference

- AD - Double Acting
D - Dutch
E - Full Panel, Single
EG - Full Glass Panel, Single
L - Top Louver
LW - Louver Window
O - Half Glass
R - Full Glass

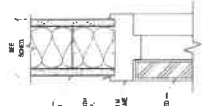

INTERIOR HM FRAME DOOR HEAD P-1147 7



INTERIOR HM FRAME DOOR JAMB P-1147 6

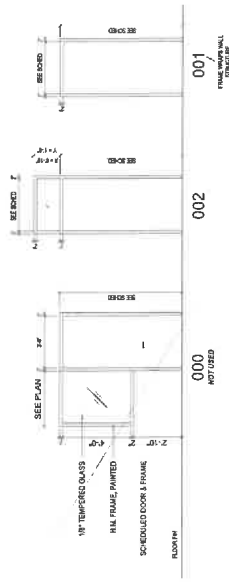

DOOR FRAME TYPE P-1147 8

DOOR SCHEDULE

DOOR SCHEDULE table with columns for No., Description, Size, Panel, Frame, and Remarks.

Hardware Schedule
Set: 1.0
Door: 541, 542, 543, 544, 545, 546, 547, 548, 549, 550, 551, 552, 553, 554, 555, 556, 557, 558, 559, 560, 561, 562, 563, 564, 565, 566, 567, 568, 569, 570, 571, 572, 573, 574, 575, 576, 577, 578, 579, 580, 581, 582, 583, 584, 585, 586, 587, 588, 589, 590, 591, 592, 593, 594, 595, 596, 597, 598, 599, 600, 601, 602, 603, 604, 605, 606, 607, 608, 609, 610, 611, 612, 613, 614, 615, 616, 617, 618, 619, 620, 621, 622, 623, 624, 625, 626, 627, 628, 629, 630, 631, 632, 633, 634, 635, 636, 637, 638, 639, 640, 641, 642, 643, 644, 645, 646, 647, 648, 649, 650, 651, 652, 653, 654, 655, 656, 657, 658, 659, 660, 661, 662, 663, 664, 665, 666, 667, 668, 669, 670, 671, 672, 673, 674, 675, 676, 677, 678, 679, 680, 681, 682, 683, 684, 685, 686, 687, 688, 689, 690, 691, 692, 693, 694, 695, 696, 697, 698, 699, 700, 701, 702, 703, 704, 705, 706, 707, 708, 709, 710, 711, 712, 713, 714, 715, 716, 717, 718, 719, 720, 721, 722, 723, 724, 725, 726, 727, 728, 729, 730, 731, 732, 733, 734, 735, 736, 737, 738, 739, 740, 741, 742, 743, 744, 745, 746, 747, 748, 749, 750, 751, 752, 753, 754, 755, 756, 757, 758, 759, 760, 761, 762, 763, 764, 765, 766, 767, 768, 769, 770, 771, 772, 773, 774, 775, 776, 777, 778, 779, 780, 781, 782, 783, 784, 785, 786, 787, 788, 789, 790, 791, 792, 793, 794, 795, 796, 797, 798, 799, 800, 801, 802, 803, 804, 805, 806, 807, 808, 809, 810, 811, 812, 813, 814, 815, 816, 817, 818, 819, 820, 821, 822, 823, 824, 825, 826, 827, 828, 829, 830, 831, 832, 833, 834, 835, 836, 837, 838, 839, 840, 841, 842, 843, 844, 845, 846, 847, 848, 849, 850, 851, 852, 853, 854, 855, 856, 857, 858, 859, 860, 861, 862, 863, 864, 865, 866, 867, 868, 869, 870, 871, 872, 873, 874, 875, 876, 877, 878, 879, 880, 881, 882, 883, 884, 885, 886, 887, 888, 889, 890, 891, 892, 893, 894, 895, 896, 897, 898, 899, 900, 901, 902, 903, 904, 905, 906, 907, 908, 909, 910, 911, 912, 913, 914, 915, 916, 917, 918, 919, 920, 921, 922, 923, 924, 925, 926, 927, 928, 929, 930, 931, 932, 933, 934, 935, 936, 937, 938, 939, 940, 941, 942, 943, 944, 945, 946, 947, 948, 949, 950, 951, 952, 953, 954, 955, 956, 957, 958, 959, 960, 961, 962, 963, 964, 965, 966, 967, 968, 969, 970, 971, 972, 973, 974, 975, 976, 977, 978, 979, 980, 981, 982, 983, 984, 985, 986, 987, 988, 989, 990, 991, 992, 993, 994, 995, 996, 997, 998, 999, 1000

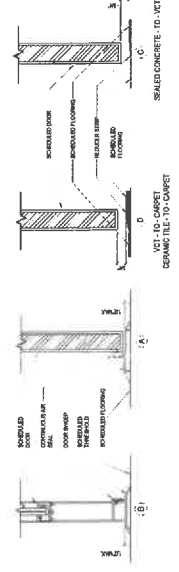

TYPE DOOR THRESHOLDS P-1147 9

PROJECT NAME: GALVESTON COUNTY MENTAL HEALTH COURT RENOVATION
PROJECT LOCATION: Galveston, Texas
PROJECT NUMBER: 1005437.00
SHEET TITLE: DOOR ASSEMBLY SCHEDULE
SHEET NUMBER: A0.30



Member Health Court



PGAL Inc.
3121 Shepherd Dr.
Houston, TX 77062
Tel: 713 822 1144
Fax: 713 822 1144
www.pgal.com

CONSULTANT

REGISTRATION
Copyright © 2018



DRAWING HISTORY
NO. DATE
BY
CHECKED BY
DATE
APPROVED BY
DATE

KEY PLAN

PROJECT NAME
HOUSTON
COUNTY
MENTAL
HEALTH COURT
RENOVATION

PROJECT LOCATION
Houston, Texas

PROJECT NUMBER
1005437.00

SHEET TITLE
OVERALL SIXTH
LEVEL FLOOR PLAN

SHEET NUMBER
A2.01

- ### GENERAL PLAN NOTES
1. ROOM AND ROOM NUMBER ARE FOR GENERAL COORDINATION ONLY.
 2. ROOMS ARE TO BE CONFORMANT WITH THE 2018 INTERNATIONAL BUILDING CODE (IBC) AND ALL APPLICABLE CODES AND REGULATIONS.
 3. ROOMS ARE TO BE CONFORMANT WITH THE 2018 INTERNATIONAL BUILDING CODE (IBC) AND ALL APPLICABLE CODES AND REGULATIONS.
 4. ALL WORK SHALL BE IN ACCORDANCE WITH THE 2018 INTERNATIONAL BUILDING CODE (IBC) AND ALL APPLICABLE CODES AND REGULATIONS.
 5. CONTRACTOR SHALL VERIFY ALL FIELD CONDITIONS PRIOR TO COMMENCEMENT OF WORK.
 6. CONTRACTOR SHALL VERIFY ALL FIELD CONDITIONS PRIOR TO COMMENCEMENT OF WORK.
 7. CONTRACTOR SHALL VERIFY ALL FIELD CONDITIONS PRIOR TO COMMENCEMENT OF WORK.
 8. CONTRACTOR SHALL VERIFY ALL FIELD CONDITIONS PRIOR TO COMMENCEMENT OF WORK.
 9. CONTRACTOR SHALL VERIFY ALL FIELD CONDITIONS PRIOR TO COMMENCEMENT OF WORK.
 10. CONTRACTOR SHALL VERIFY ALL FIELD CONDITIONS PRIOR TO COMMENCEMENT OF WORK.
 11. ALL DIMENSIONS ARE THE UNLESS NOTED OTHERWISE.

- ### PLAN GRAPHICS LEGEND
- 1. ROOM NUMBER TO ROOM
 - 2. ROOM NUMBER TO ROOM
 - 3. ROOM NUMBER TO ROOM
 - 4. ROOM NUMBER TO ROOM
 - 5. ROOM NUMBER TO ROOM
 - 6. ROOM NUMBER TO ROOM
 - 7. ROOM NUMBER TO ROOM
 - 8. ROOM NUMBER TO ROOM
 - 9. ROOM NUMBER TO ROOM
 - 10. ROOM NUMBER TO ROOM
 - 11. ROOM NUMBER TO ROOM
 - 12. ROOM NUMBER TO ROOM
 - 13. ROOM NUMBER TO ROOM
 - 14. ROOM NUMBER TO ROOM
 - 15. ROOM NUMBER TO ROOM
 - 16. ROOM NUMBER TO ROOM
 - 17. ROOM NUMBER TO ROOM
 - 18. ROOM NUMBER TO ROOM
 - 19. ROOM NUMBER TO ROOM
 - 20. ROOM NUMBER TO ROOM
 - 21. ROOM NUMBER TO ROOM
 - 22. ROOM NUMBER TO ROOM
 - 23. ROOM NUMBER TO ROOM
 - 24. ROOM NUMBER TO ROOM
 - 25. ROOM NUMBER TO ROOM
 - 26. ROOM NUMBER TO ROOM
 - 27. ROOM NUMBER TO ROOM
 - 28. ROOM NUMBER TO ROOM
 - 29. ROOM NUMBER TO ROOM
 - 30. ROOM NUMBER TO ROOM
 - 31. ROOM NUMBER TO ROOM
 - 32. ROOM NUMBER TO ROOM
 - 33. ROOM NUMBER TO ROOM
 - 34. ROOM NUMBER TO ROOM
 - 35. ROOM NUMBER TO ROOM
 - 36. ROOM NUMBER TO ROOM
 - 37. ROOM NUMBER TO ROOM
 - 38. ROOM NUMBER TO ROOM
 - 39. ROOM NUMBER TO ROOM
 - 40. ROOM NUMBER TO ROOM
 - 41. ROOM NUMBER TO ROOM
 - 42. ROOM NUMBER TO ROOM
 - 43. ROOM NUMBER TO ROOM
 - 44. ROOM NUMBER TO ROOM
 - 45. ROOM NUMBER TO ROOM
 - 46. ROOM NUMBER TO ROOM
 - 47. ROOM NUMBER TO ROOM
 - 48. ROOM NUMBER TO ROOM
 - 49. ROOM NUMBER TO ROOM
 - 50. ROOM NUMBER TO ROOM
 - 51. ROOM NUMBER TO ROOM
 - 52. ROOM NUMBER TO ROOM
 - 53. ROOM NUMBER TO ROOM
 - 54. ROOM NUMBER TO ROOM
 - 55. ROOM NUMBER TO ROOM
 - 56. ROOM NUMBER TO ROOM
 - 57. ROOM NUMBER TO ROOM
 - 58. ROOM NUMBER TO ROOM
 - 59. ROOM NUMBER TO ROOM
 - 60. ROOM NUMBER TO ROOM
 - 61. ROOM NUMBER TO ROOM
 - 62. ROOM NUMBER TO ROOM
 - 63. ROOM NUMBER TO ROOM
 - 64. ROOM NUMBER TO ROOM
 - 65. ROOM NUMBER TO ROOM
 - 66. ROOM NUMBER TO ROOM
 - 67. ROOM NUMBER TO ROOM
 - 68. ROOM NUMBER TO ROOM
 - 69. ROOM NUMBER TO ROOM
 - 70. ROOM NUMBER TO ROOM
 - 71. ROOM NUMBER TO ROOM
 - 72. ROOM NUMBER TO ROOM
 - 73. ROOM NUMBER TO ROOM
 - 74. ROOM NUMBER TO ROOM
 - 75. ROOM NUMBER TO ROOM
 - 76. ROOM NUMBER TO ROOM
 - 77. ROOM NUMBER TO ROOM
 - 78. ROOM NUMBER TO ROOM
 - 79. ROOM NUMBER TO ROOM
 - 80. ROOM NUMBER TO ROOM
 - 81. ROOM NUMBER TO ROOM
 - 82. ROOM NUMBER TO ROOM
 - 83. ROOM NUMBER TO ROOM
 - 84. ROOM NUMBER TO ROOM
 - 85. ROOM NUMBER TO ROOM
 - 86. ROOM NUMBER TO ROOM
 - 87. ROOM NUMBER TO ROOM
 - 88. ROOM NUMBER TO ROOM
 - 89. ROOM NUMBER TO ROOM
 - 90. ROOM NUMBER TO ROOM
 - 91. ROOM NUMBER TO ROOM
 - 92. ROOM NUMBER TO ROOM
 - 93. ROOM NUMBER TO ROOM
 - 94. ROOM NUMBER TO ROOM
 - 95. ROOM NUMBER TO ROOM
 - 96. ROOM NUMBER TO ROOM
 - 97. ROOM NUMBER TO ROOM
 - 98. ROOM NUMBER TO ROOM
 - 99. ROOM NUMBER TO ROOM
 - 100. ROOM NUMBER TO ROOM

KEYED NOTES

NOTE: ROOM NUMBERING IS FOR INFORMATIONAL PURPOSES ONLY AND IS NOT TO BE USED FOR IDENTIFICATION PURPOSES.

NUMBER DESCRIPTION

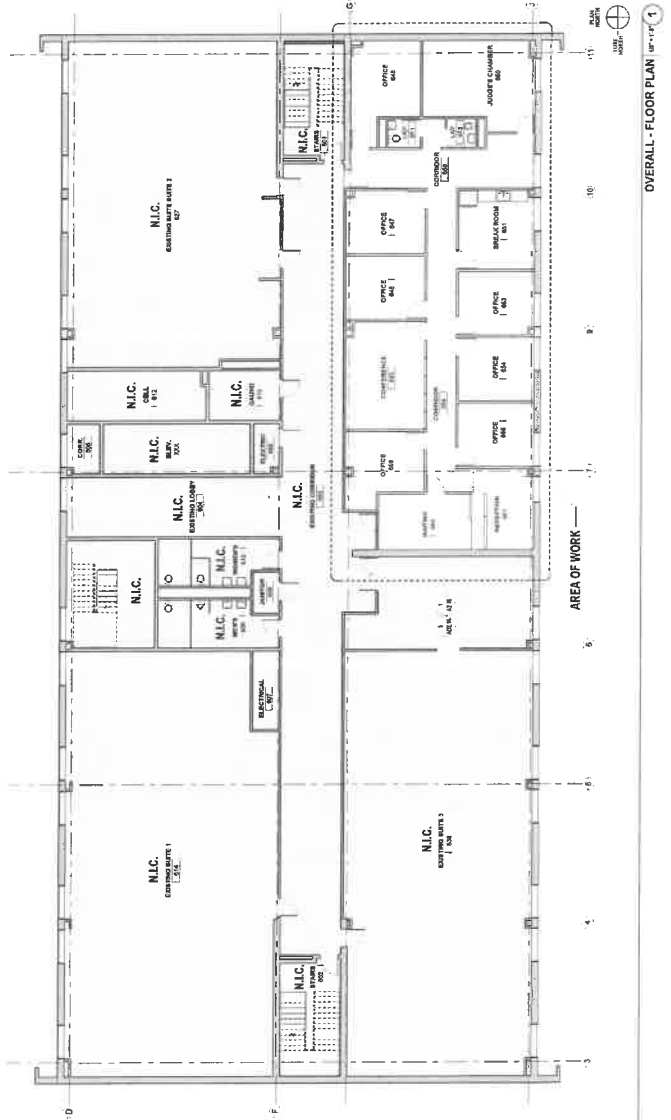

OVERALL - FLOOR PLAN 1/8"=1'-0" (1)



CLIENT: GALVESTON COUNTY HEALTH COURT
 ARCHITECT: PGAL
 PGAL, Inc.
 2000 West Loop West, Suite 200
 Houston, TX 77056
 P: 713.621.4442
 F: 713.621.1444
 www.pgal.com



PROJECT NUMBER: 1006457.00
 SHEET TITLE: PARTIAL SIXTH LEVEL DEMOLITION PLAN
 PROJECT LOCATION: Galveston, Texas

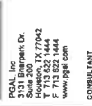

REGISTERED PROFESSIONAL ENGINEER
 STATE OF TEXAS
 NO. 1006457.00
 EXPIRES: 12/31/2024
 DATE: 12/31/2024



REGISTERED PROFESSIONAL ARCHITECT
 STATE OF TEXAS
 NO. 1006457.00
 EXPIRES: 12/31/2024
 DATE: 12/31/2024

GENERAL PLAN NOTES

1. CONSULT ALL CONTRACTS WITH THIS DRAWING FOR CONFLICTS.
2. VERIFY ALL DIMENSIONS AND LOCATIONS OF EXISTING CONDITIONS.
3. ALL DIMENSIONS ARE TO FACE UNLESS OTHERWISE NOTED.
4. ALL DIMENSIONS ARE TO FACE UNLESS OTHERWISE NOTED.
5. ALL DIMENSIONS ARE TO FACE UNLESS OTHERWISE NOTED.
6. ALL DIMENSIONS ARE TO FACE UNLESS OTHERWISE NOTED.
7. ALL DIMENSIONS ARE TO FACE UNLESS OTHERWISE NOTED.
8. ALL DIMENSIONS ARE TO FACE UNLESS OTHERWISE NOTED.
9. ALL DIMENSIONS ARE TO FACE UNLESS OTHERWISE NOTED.
10. ALL DIMENSIONS ARE TO FACE UNLESS OTHERWISE NOTED.
11. ALL DIMENSIONS ARE TO FACE UNLESS OTHERWISE NOTED.
12. ALL DIMENSIONS ARE TO FACE UNLESS OTHERWISE NOTED.
13. ALL DIMENSIONS ARE TO FACE UNLESS OTHERWISE NOTED.
14. ALL DIMENSIONS ARE TO FACE UNLESS OTHERWISE NOTED.
15. ALL DIMENSIONS ARE TO FACE UNLESS OTHERWISE NOTED.
16. ALL DIMENSIONS ARE TO FACE UNLESS OTHERWISE NOTED.
17. ALL DIMENSIONS ARE TO FACE UNLESS OTHERWISE NOTED.
18. ALL DIMENSIONS ARE TO FACE UNLESS OTHERWISE NOTED.
19. ALL DIMENSIONS ARE TO FACE UNLESS OTHERWISE NOTED.
20. ALL DIMENSIONS ARE TO FACE UNLESS OTHERWISE NOTED.

PLAN GRAPHICS LEGEND

- EXISTING PARTITION TO REMAIN
- NEW SCHEDULE PARTITION
- EXISTING PARTITION TO DEMOLISH
- DEMOLITION LINE

KEYED NOTES

1. DEMOLITION LINE
 2. DEMOLITION LINE
 3. DEMOLITION LINE
 4. DEMOLITION LINE
 5. DEMOLITION LINE
 6. DEMOLITION LINE
 7. DEMOLITION LINE
 8. DEMOLITION LINE
 9. DEMOLITION LINE
 10. DEMOLITION LINE
 11. DEMOLITION LINE
 12. DEMOLITION LINE
 13. DEMOLITION LINE
 14. DEMOLITION LINE
 15. DEMOLITION LINE
 16. DEMOLITION LINE
 17. DEMOLITION LINE
 18. DEMOLITION LINE
 19. DEMOLITION LINE
 20. DEMOLITION LINE

NUMBER	DESCRIPTION
1	REMOVE EXISTING WALLS, FLOOR AND CEILING FOR DEMOLITION.
2	REMOVE EXISTING WALLS, FLOOR AND CEILING FOR DEMOLITION.
3	REMOVE EXISTING WALLS, FLOOR AND CEILING FOR DEMOLITION.
4	REMOVE EXISTING WALLS, FLOOR AND CEILING FOR DEMOLITION.
5	REMOVE EXISTING WALLS, FLOOR AND CEILING FOR DEMOLITION.
6	REMOVE EXISTING WALLS, FLOOR AND CEILING FOR DEMOLITION.
7	REMOVE EXISTING WALLS, FLOOR AND CEILING FOR DEMOLITION.
8	REMOVE EXISTING WALLS, FLOOR AND CEILING FOR DEMOLITION.
9	REMOVE EXISTING WALLS, FLOOR AND CEILING FOR DEMOLITION.
10	REMOVE EXISTING WALLS, FLOOR AND CEILING FOR DEMOLITION.
11	REMOVE EXISTING WALLS, FLOOR AND CEILING FOR DEMOLITION.
12	REMOVE EXISTING WALLS, FLOOR AND CEILING FOR DEMOLITION.
13	REMOVE EXISTING WALLS, FLOOR AND CEILING FOR DEMOLITION.
14	REMOVE EXISTING WALLS, FLOOR AND CEILING FOR DEMOLITION.
15	REMOVE EXISTING WALLS, FLOOR AND CEILING FOR DEMOLITION.
16	REMOVE EXISTING WALLS, FLOOR AND CEILING FOR DEMOLITION.
17	REMOVE EXISTING WALLS, FLOOR AND CEILING FOR DEMOLITION.
18	REMOVE EXISTING WALLS, FLOOR AND CEILING FOR DEMOLITION.
19	REMOVE EXISTING WALLS, FLOOR AND CEILING FOR DEMOLITION.
20	REMOVE EXISTING WALLS, FLOOR AND CEILING FOR DEMOLITION.

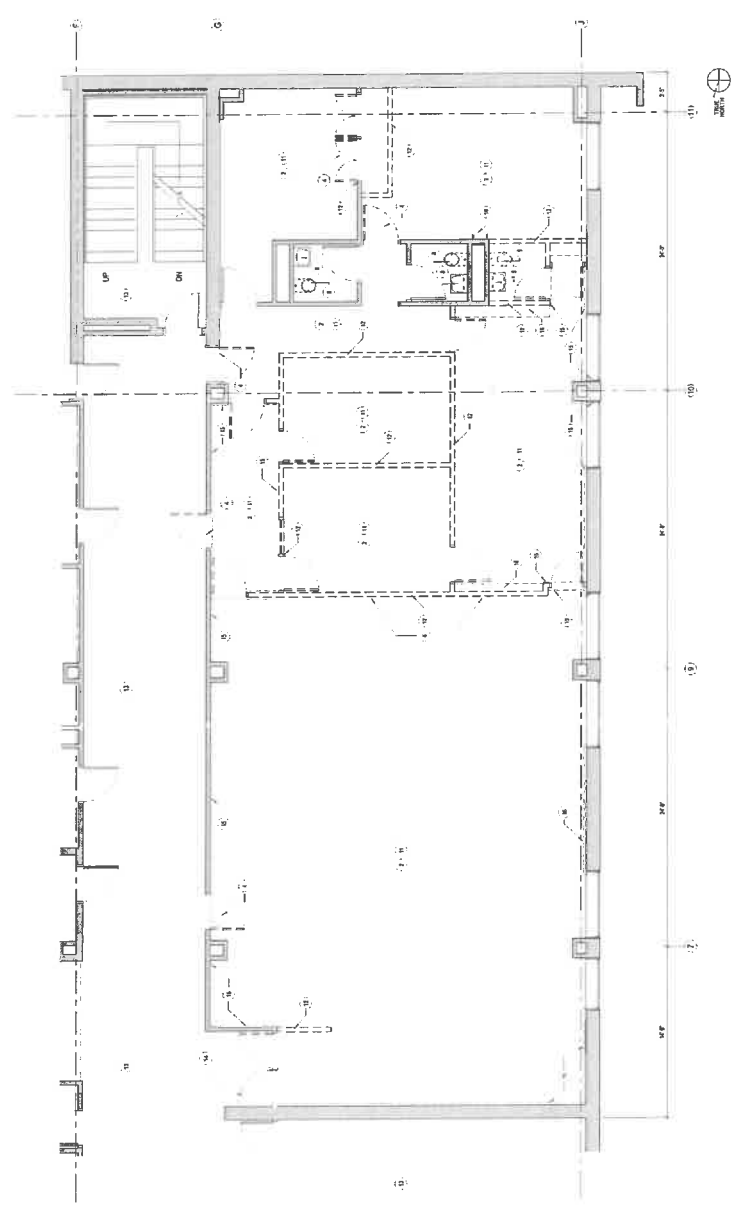

SIXTH FLOOR - DEMOLITION PLAN - RCP-5

GENERAL PLAN NOTES

1. CONSULT ALL CONTRACTS WITH THIS DRAWING FOR CONFLICTS.
2. VERIFY ALL DIMENSIONS AND LOCATIONS OF EXISTING CONDITIONS.
3. ALL DIMENSIONS ARE TO FACE UNLESS OTHERWISE NOTED.
4. ALL DIMENSIONS ARE TO FACE UNLESS OTHERWISE NOTED.
5. ALL DIMENSIONS ARE TO FACE UNLESS OTHERWISE NOTED.
6. ALL DIMENSIONS ARE TO FACE UNLESS OTHERWISE NOTED.
7. ALL DIMENSIONS ARE TO FACE UNLESS OTHERWISE NOTED.
8. ALL DIMENSIONS ARE TO FACE UNLESS OTHERWISE NOTED.
9. ALL DIMENSIONS ARE TO FACE UNLESS OTHERWISE NOTED.
10. ALL DIMENSIONS ARE TO FACE UNLESS OTHERWISE NOTED.
11. ALL DIMENSIONS ARE TO FACE UNLESS OTHERWISE NOTED.
12. ALL DIMENSIONS ARE TO FACE UNLESS OTHERWISE NOTED.
13. ALL DIMENSIONS ARE TO FACE UNLESS OTHERWISE NOTED.
14. ALL DIMENSIONS ARE TO FACE UNLESS OTHERWISE NOTED.
15. ALL DIMENSIONS ARE TO FACE UNLESS OTHERWISE NOTED.
16. ALL DIMENSIONS ARE TO FACE UNLESS OTHERWISE NOTED.
17. ALL DIMENSIONS ARE TO FACE UNLESS OTHERWISE NOTED.
18. ALL DIMENSIONS ARE TO FACE UNLESS OTHERWISE NOTED.
19. ALL DIMENSIONS ARE TO FACE UNLESS OTHERWISE NOTED.
20. ALL DIMENSIONS ARE TO FACE UNLESS OTHERWISE NOTED.

PLAN GRAPHICS LEGEND

- EXISTING PARTITION TO REMAIN
- NEW SCHEDULE PARTITION
- EXISTING PARTITION TO DEMOLISH
- DEMOLITION LINE

KEYED NOTES

1. DEMOLITION LINE
 2. DEMOLITION LINE
 3. DEMOLITION LINE
 4. DEMOLITION LINE
 5. DEMOLITION LINE
 6. DEMOLITION LINE
 7. DEMOLITION LINE
 8. DEMOLITION LINE
 9. DEMOLITION LINE
 10. DEMOLITION LINE
 11. DEMOLITION LINE
 12. DEMOLITION LINE
 13. DEMOLITION LINE
 14. DEMOLITION LINE
 15. DEMOLITION LINE
 16. DEMOLITION LINE
 17. DEMOLITION LINE
 18. DEMOLITION LINE
 19. DEMOLITION LINE
 20. DEMOLITION LINE

NUMBER	DESCRIPTION
1	REMOVE EXISTING WALLS, FLOOR AND CEILING FOR DEMOLITION.
2	REMOVE EXISTING WALLS, FLOOR AND CEILING FOR DEMOLITION.
3	REMOVE EXISTING WALLS, FLOOR AND CEILING FOR DEMOLITION.
4	REMOVE EXISTING WALLS, FLOOR AND CEILING FOR DEMOLITION.
5	REMOVE EXISTING WALLS, FLOOR AND CEILING FOR DEMOLITION.
6	REMOVE EXISTING WALLS, FLOOR AND CEILING FOR DEMOLITION.
7	REMOVE EXISTING WALLS, FLOOR AND CEILING FOR DEMOLITION.
8	REMOVE EXISTING WALLS, FLOOR AND CEILING FOR DEMOLITION.
9	REMOVE EXISTING WALLS, FLOOR AND CEILING FOR DEMOLITION.
10	REMOVE EXISTING WALLS, FLOOR AND CEILING FOR DEMOLITION.
11	REMOVE EXISTING WALLS, FLOOR AND CEILING FOR DEMOLITION.
12	REMOVE EXISTING WALLS, FLOOR AND CEILING FOR DEMOLITION.
13	REMOVE EXISTING WALLS, FLOOR AND CEILING FOR DEMOLITION.
14	REMOVE EXISTING WALLS, FLOOR AND CEILING FOR DEMOLITION.
15	REMOVE EXISTING WALLS, FLOOR AND CEILING FOR DEMOLITION.
16	REMOVE EXISTING WALLS, FLOOR AND CEILING FOR DEMOLITION.
17	REMOVE EXISTING WALLS, FLOOR AND CEILING FOR DEMOLITION.
18	REMOVE EXISTING WALLS, FLOOR AND CEILING FOR DEMOLITION.
19	REMOVE EXISTING WALLS, FLOOR AND CEILING FOR DEMOLITION.
20	REMOVE EXISTING WALLS, FLOOR AND CEILING FOR DEMOLITION.



SIXTH FLOOR - DEMOLITION PLAN - RCP-5

DATE STAMP: 8/22/2024 4:32:47 PM
 FILE: C:\Projects\1006457\02_GM\HQ\ARCH\RCP-5

PROJECT NAME: GALVESTON COUNTY MENTAL HEALTH COURT RENOVATION
 PROJECT LOCATION: Galveston, Texas
 PROJECT NUMBER: 1006457.00
 SHEET TITLE: PARTIAL SIXTH LEVEL DEMOLITION PLAN
 SHEET NUMBER: AD2.10

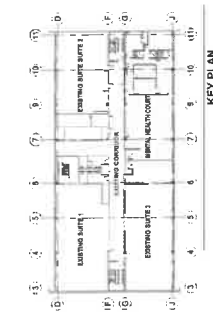

KEY PLAN



CLERK
Mental Health Court



PGAL, Inc.
3331 S. Lamar Blvd.
Austin, TX 78746
P: 713.822.1444
www.pgal.com

CONSULTANT

REGISTERED ARCHITECT
COMPLIANT 02/2018



DATE: 02/22/2021
DRAWING NO: 1005437.00
PROJECT NO: 1005437.00

KEY PLAN

PROJECT NAME
MENTAL HEALTH COURT
COUNTY
MENTAL HEALTH COURT
RENOVATION
PROJECT LOCATION
CONVULSION, TEXAS

PROJECT NUMBER
1005437.00

SHEET TITLE
MENTAL HEALTH COURT
ENLARGED PLAN

SHEET NUMBER
A2.10

GENERAL PLAN NOTES

1. CONSULTANT HAS REVIEWED THE ARCHITECTURAL DRAWINGS FOR CONFORMANCE WITH THE 2018 INTERNATIONAL BUILDING CODE (IBC) AND THE 2018 INTERNATIONAL PLUMBING AND MECHANICAL CODE (IMC). THE ARCHITECT IS RESPONSIBLE FOR OBTAINING ALL NECESSARY PERMITS AND APPROVALS FROM THE LOCAL JURISDICTION.
2. ALL DIMENSIONS ARE IN FEET AND INCHES. DIMENSIONS ARE SHOWN TO THE CENTER OF FINISH SURFACES UNLESS OTHERWISE NOTED.
3. ALL DIMENSIONS ARE TO THE CENTER OF FINISH SURFACES UNLESS OTHERWISE NOTED.
4. ALL DIMENSIONS ARE TO THE CENTER OF FINISH SURFACES UNLESS OTHERWISE NOTED.
5. ALL DIMENSIONS ARE TO THE CENTER OF FINISH SURFACES UNLESS OTHERWISE NOTED.
6. ALL DIMENSIONS ARE TO THE CENTER OF FINISH SURFACES UNLESS OTHERWISE NOTED.
7. ALL DIMENSIONS ARE TO THE CENTER OF FINISH SURFACES UNLESS OTHERWISE NOTED.
8. ALL DIMENSIONS ARE TO THE CENTER OF FINISH SURFACES UNLESS OTHERWISE NOTED.
9. ALL DIMENSIONS ARE TO THE CENTER OF FINISH SURFACES UNLESS OTHERWISE NOTED.
10. ALL DIMENSIONS ARE TO THE CENTER OF FINISH SURFACES UNLESS OTHERWISE NOTED.

PLAN GRAPHICS LEGEND

- EXISTING PARTITION WALL
- NEW PARTITION WALL
- EXISTING DOOR
- NEW DOOR
- EXISTING WINDOW
- NEW WINDOW
- EXISTING STAIR
- NEW STAIR
- EXISTING ELEVATOR
- NEW ELEVATOR
- EXISTING MECHANICAL EQUIPMENT
- NEW MECHANICAL EQUIPMENT
- EXISTING ELECTRICAL EQUIPMENT
- NEW ELECTRICAL EQUIPMENT
- EXISTING PLUMBING EQUIPMENT
- NEW PLUMBING EQUIPMENT

KEYED NOTES

- | NUMBER | DESCRIPTION |
|--------|---|
| 1 | YELLOW METAL HORIZONTAL FINISH TO EXISTING CEILING, SEE A10 |
| 2 | WHITE METAL HORIZONTAL FINISH TO EXISTING CEILING, SEE A10 |
| 3 | WHITE METAL HORIZONTAL FINISH TO EXISTING CEILING, SEE A10 |
| 4 | WHITE METAL HORIZONTAL FINISH TO EXISTING CEILING, SEE A10 |
| 5 | WHITE METAL HORIZONTAL FINISH TO EXISTING CEILING, SEE A10 |
| 6 | WHITE METAL HORIZONTAL FINISH TO EXISTING CEILING, SEE A10 |
| 7 | WHITE METAL HORIZONTAL FINISH TO EXISTING CEILING, SEE A10 |
| 8 | WHITE METAL HORIZONTAL FINISH TO EXISTING CEILING, SEE A10 |
| 9 | WHITE METAL HORIZONTAL FINISH TO EXISTING CEILING, SEE A10 |
| 10 | WHITE METAL HORIZONTAL FINISH TO EXISTING CEILING, SEE A10 |

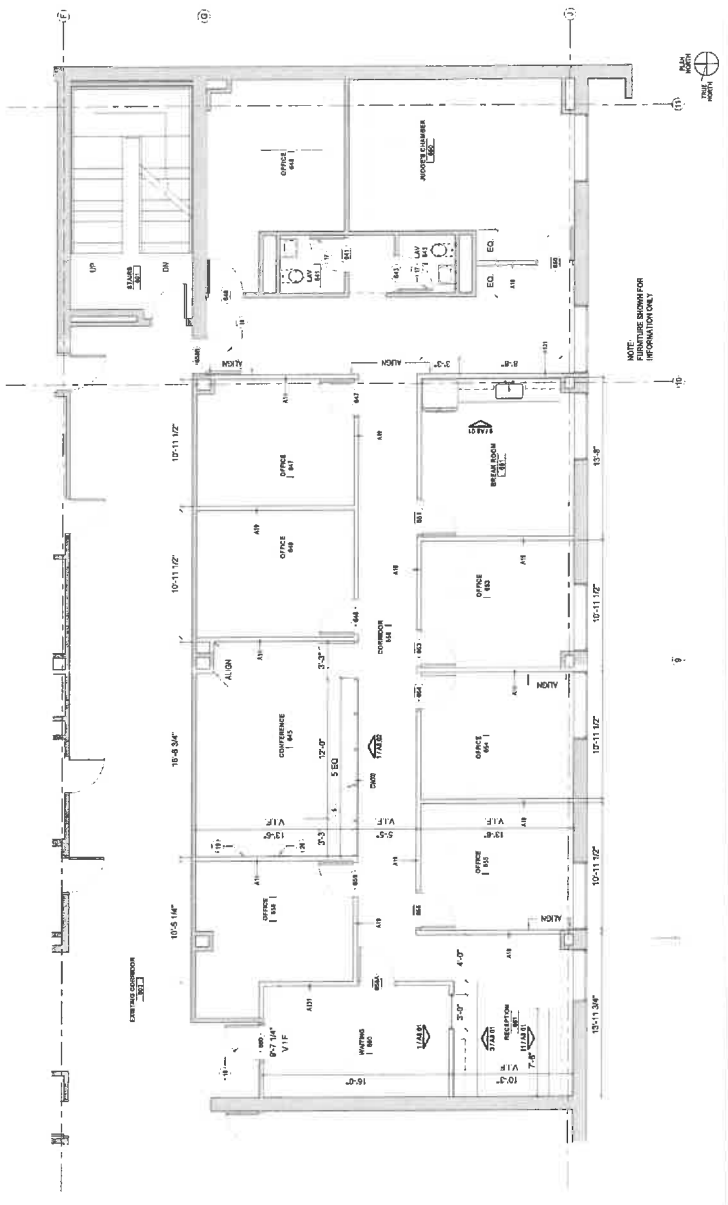

SIXTH FLOOR PLAN - 1

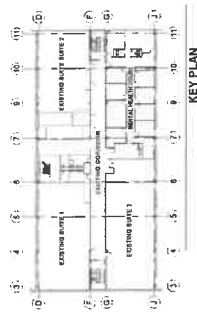

KEY PLAN

CLIENT



Marshall Health Court

ARCHITECT



PGAL, Inc.
3131 S. Greenway Dr.
Houston, TX 77024
P: 713 822 1444
www.pgal.com

CONSULTANT

REGISTRATION

Copyright © 2014



DATE: 02/27/2014

PROJECT NO. 140000

PROJECT NAME: MARSHALL HEALTH COURT

PROJECT LOCATION: HOUSTON, TEXAS

PROJECT NUMBER: 1005437.00

SHEET TITLE: REFLECTED CEILING PLAN

SHEET NUMBER: A3.10

GENERAL RCP NOTES

1. VERIFY ALL DIMENSIONS AND CONDITIONS ARE SHOWN AND VERIFY WITH THE CONTRACTOR PRIOR TO CONSTRUCTION.
2. VERIFY ALL DIMENSIONS AND CONDITIONS ARE SHOWN AND VERIFY WITH THE CONTRACTOR PRIOR TO CONSTRUCTION.
3. VERIFY ALL DIMENSIONS AND CONDITIONS ARE SHOWN AND VERIFY WITH THE CONTRACTOR PRIOR TO CONSTRUCTION.
4. VERIFY ALL DIMENSIONS AND CONDITIONS ARE SHOWN AND VERIFY WITH THE CONTRACTOR PRIOR TO CONSTRUCTION.
5. VERIFY ALL DIMENSIONS AND CONDITIONS ARE SHOWN AND VERIFY WITH THE CONTRACTOR PRIOR TO CONSTRUCTION.
6. VERIFY ALL DIMENSIONS AND CONDITIONS ARE SHOWN AND VERIFY WITH THE CONTRACTOR PRIOR TO CONSTRUCTION.
7. VERIFY ALL DIMENSIONS AND CONDITIONS ARE SHOWN AND VERIFY WITH THE CONTRACTOR PRIOR TO CONSTRUCTION.
8. VERIFY ALL DIMENSIONS AND CONDITIONS ARE SHOWN AND VERIFY WITH THE CONTRACTOR PRIOR TO CONSTRUCTION.

RCP GRAPHIC LEGEND

- 1. HOLLOW CORE CEILING TILE PER ISG
- 2. HOLLOW CORE CEILING TILE PER ISG
- 3. HOLLOW CORE CEILING TILE PER ISG
- 4. HOLLOW CORE CEILING TILE PER ISG
- 5. HOLLOW CORE CEILING TILE PER ISG
- 6. HOLLOW CORE CEILING TILE PER ISG
- 7. HOLLOW CORE CEILING TILE PER ISG
- 8. HOLLOW CORE CEILING TILE PER ISG

KEYNOTE LEGEND

- 1. HOLLOW CORE CEILING TILE PER ISG
- 2. HOLLOW CORE CEILING TILE PER ISG
- 3. HOLLOW CORE CEILING TILE PER ISG
- 4. HOLLOW CORE CEILING TILE PER ISG
- 5. HOLLOW CORE CEILING TILE PER ISG
- 6. HOLLOW CORE CEILING TILE PER ISG
- 7. HOLLOW CORE CEILING TILE PER ISG
- 8. HOLLOW CORE CEILING TILE PER ISG

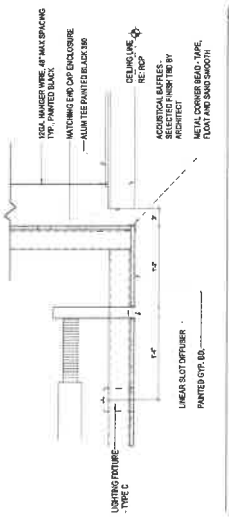

DETAIL @ ACOUSTICAL Baffles in CONFERENCE room



REFLECTED CEILING PLAN

DATE: 02/27/2014 4:52:24 PM

PROJECT NO. 140000

PROJECT NAME: MARSHALL HEALTH COURT

PROJECT LOCATION: HOUSTON, TEXAS

PROJECT NUMBER: 1005437.00

SHEET TITLE: REFLECTED CEILING PLAN

SHEET NUMBER: A3.10

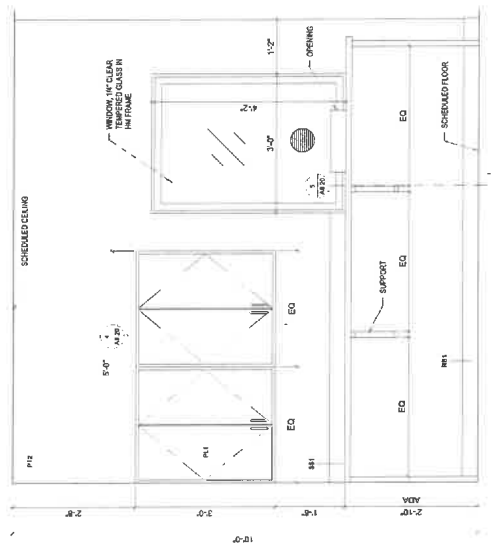

681 RECEPTION - NORTH 1'-1/4" = 1'-0" 3

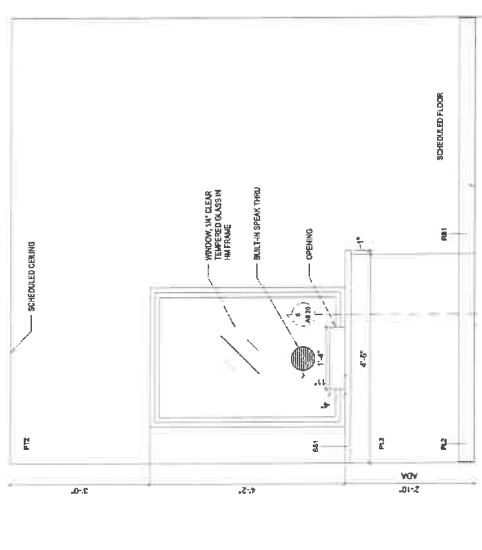

OPTION 1 - 680 WAITING - SOUTH 1'-1/4" = 1'-0" 1

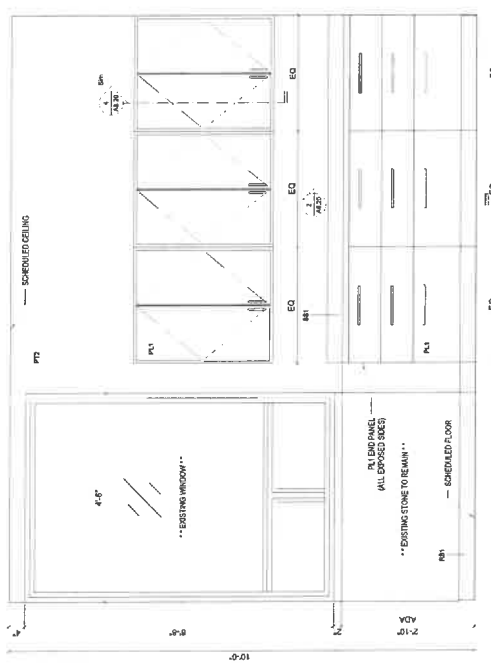

681 RECEPTION - SOUTH 1'-1/4" = 1'-0" 11

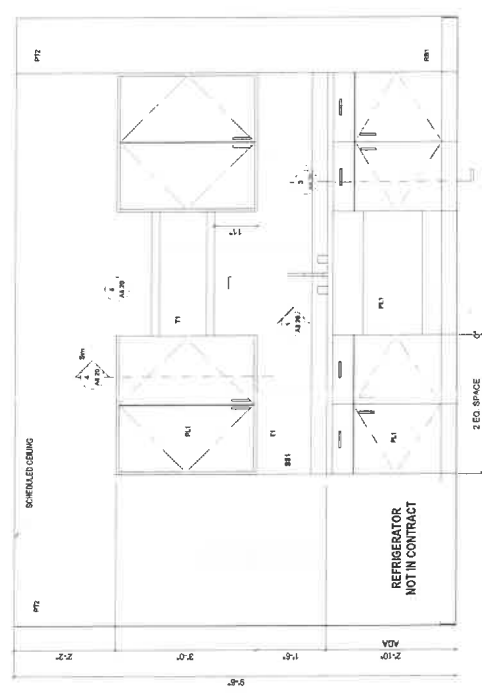

681 BREAK - EAST 1'-1/4" = 1'-0" 9



State of Texas
Mental Health Court



PG&AL, Inc.
2121 Baymark Dr.
Houston, TX 77292
P 713 821 4444
www.pgandal.com

CONSULTANT

REGISTRATION NO.
Contract # 20178



DRAWING HISTORY

NO.	DATE	DESCRIPTION

PROJECT NAME
CALVESTON
COUNTY
MENTAL
HEALTH COURT
RENOVATION
PROJECT LOCATION
Galveston, Texas

PROJECT NUMBER
1005437.00

SHEET TITLE
INTERIOR
ELEVATIONS

SHEET NUMBER
A8.02

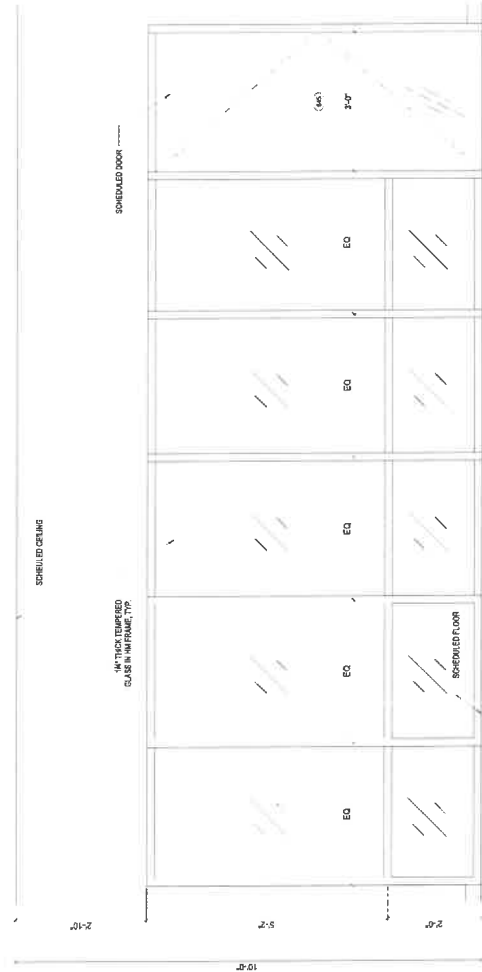

CONFERENCE WINDOWS - 1



CLIENT: MENTAL HEALTH COURT



PG&AL, Inc.
 2000 West Loop South
 Suite 300
 Houston, TX 77027
 P: 713.852.1444
 www.pgandal.com

CONSULTANT:

REGISTRATION:
 Copyright © 2016



EXAMINER'S SIGNATURE:
 DATE:
 EXPIRES:

PROJECT NAME:
 GALVESTON COUNTY
 MENTAL HEALTH COURT
 RENOVATION

PROJECT LOCATION:
 Galveston, Texas

PROJECT NUMBER:
 1005457.00

SHEET TITLE:
 CASEWORK
 DETAILS

SHEET NUMBER:
 A8.20

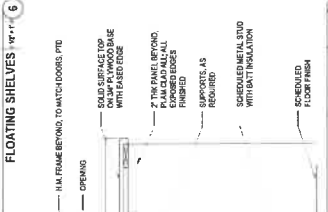
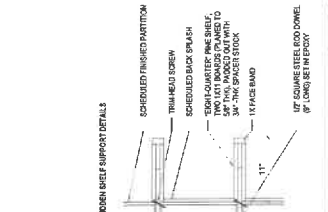
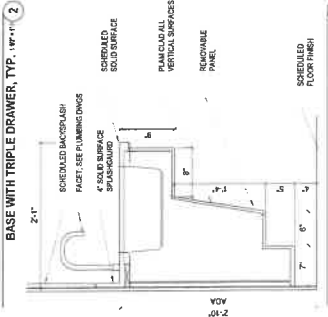
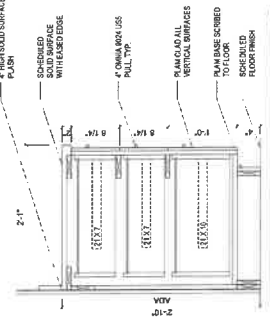
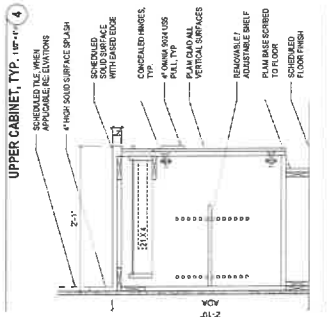
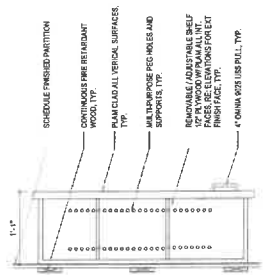



SEAL OF THE STATE OF TEXAS

State of Texas
Capital: Austin
Population: 25.1 million
Area: 695,621 sq. miles
Founded: 1846

ARCHITECT

PGAL

PGAL Inc
5031 S. Loop West
Houston, TX 77056
P: 713.825.1444
www.pgal.com

CONSULTANT

HINKLEY GROUP ASSOCIATES

HINKLEY GROUP ASSOCIATES
MANUFACTURING AND CONSTRUCTION
12000 W. Loop South
Houston, TX 77042
P: 713.825.1444
www.hinkleygroup.com

REGISTRATION NO.

CONTRACT NO.



DETAILED HISTORY

DATE	DESCRIPTION

REV PLAN

PROJECT NAME
COUNTY
CITY
MENTAL HEALTH COURT
RENOVATION

PROJECT LOCATION
722 Moody Avenue, 6th
Floor, Galveston,
Texas 77550

PROJECT NUMBER
1005437.00

SHEET TITLE
PLAN - DEMOLITION
- HVAC

SHEET NUMBER
M1.01

GENERAL NOTES

1. REFER TO ALL NOTES IN THE MECHANICAL AND ELECTRICAL SCHEDULES AND SPECIFICATIONS FOR MATERIALS, METHODS, AND WORKMANSHIP. ALL WORK SHALL BE IN ACCORDANCE WITH THE MECHANICAL AND ELECTRICAL CODES AND ALL RELATED REGULATIONS.

- LEGEND**
- ① EXISTING SUPPLY AIR DUCTS AND ASSOCIATED BRANCH DUCTS TO REMAIN
 - ② EXISTING EXHAUST THROUGH ROOF - CLEAN AND STONE FOR REUSE
 - ③ EXISTING SUPPLY AIR DISTRIBUTION GRILLE TO REMAIN

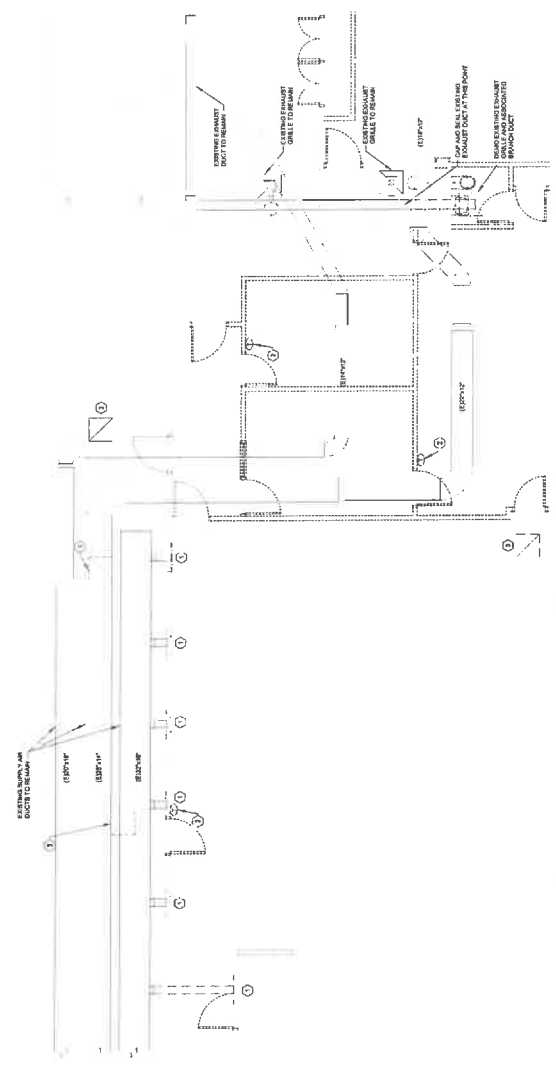

ENLARGED FLOOR PLAN - DEMOLITION - HVAC
Scale: 1/4" = 1'-0"



CLIENT
STATE OF TEXAS
 Department of Transportation
 Mental Health Court
 Galveston, Texas
 T. Phone: 409.775.7242
 F. Fax: 409.775.7242
 ARCHITECT



PGAL, Inc.
 5011 Springdale Dr.
 Houston, TX 77062
 P: 713.822.1444
 www.pgal.com

Consultant
**Industrial
 Associates**
 11455 West Loop West, Suite 200
 Houston, Texas 77042
 P: 281.416.1100
 www.iaassoc.com



REGISTRATION
 Copyright © 2007
 02/22/2007
 DRAWING HISTORY
 1 2007 02/22/2007
 2 2007 02/22/2007

PROJECT NAME
 GUESTION
 COURT
 MENTAL
 HEALTH COURT
 RENOVATION

PROJECT LOCATION
 7000 Springdale Dr.
 Floor: Galveston, TX
 Texas 77550

PROJECT NUMBER
 1005437.00

SHEET TITLE
 ENLARGED FLOOR
 PLAN - PROPOSED -
 HVAC

SHEET NUMBER
 M2.01

NOTES:
 1. ALL WORK SHALL BE IN ACCORDANCE WITH THE LATEST EDITIONS OF THE INTERNATIONAL MECHANICAL ELECTRICAL PLUMBING (IMEP) CODES AND ALL APPLICABLE LOCAL, STATE AND FEDERAL REGULATIONS.
 2. ALL WORK SHALL BE IN ACCORDANCE WITH THE LATEST EDITIONS OF THE INTERNATIONAL MECHANICAL ELECTRICAL PLUMBING (IMEP) CODES AND ALL APPLICABLE LOCAL, STATE AND FEDERAL REGULATIONS.
 3. ALL WORK SHALL BE IN ACCORDANCE WITH THE LATEST EDITIONS OF THE INTERNATIONAL MECHANICAL ELECTRICAL PLUMBING (IMEP) CODES AND ALL APPLICABLE LOCAL, STATE AND FEDERAL REGULATIONS.
 4. ALL WORK SHALL BE IN ACCORDANCE WITH THE LATEST EDITIONS OF THE INTERNATIONAL MECHANICAL ELECTRICAL PLUMBING (IMEP) CODES AND ALL APPLICABLE LOCAL, STATE AND FEDERAL REGULATIONS.
 5. ALL WORK SHALL BE IN ACCORDANCE WITH THE LATEST EDITIONS OF THE INTERNATIONAL MECHANICAL ELECTRICAL PLUMBING (IMEP) CODES AND ALL APPLICABLE LOCAL, STATE AND FEDERAL REGULATIONS.
 6. ALL WORK SHALL BE IN ACCORDANCE WITH THE LATEST EDITIONS OF THE INTERNATIONAL MECHANICAL ELECTRICAL PLUMBING (IMEP) CODES AND ALL APPLICABLE LOCAL, STATE AND FEDERAL REGULATIONS.
 7. ALL WORK SHALL BE IN ACCORDANCE WITH THE LATEST EDITIONS OF THE INTERNATIONAL MECHANICAL ELECTRICAL PLUMBING (IMEP) CODES AND ALL APPLICABLE LOCAL, STATE AND FEDERAL REGULATIONS.
 8. ALL WORK SHALL BE IN ACCORDANCE WITH THE LATEST EDITIONS OF THE INTERNATIONAL MECHANICAL ELECTRICAL PLUMBING (IMEP) CODES AND ALL APPLICABLE LOCAL, STATE AND FEDERAL REGULATIONS.
 9. ALL WORK SHALL BE IN ACCORDANCE WITH THE LATEST EDITIONS OF THE INTERNATIONAL MECHANICAL ELECTRICAL PLUMBING (IMEP) CODES AND ALL APPLICABLE LOCAL, STATE AND FEDERAL REGULATIONS.
 10. ALL WORK SHALL BE IN ACCORDANCE WITH THE LATEST EDITIONS OF THE INTERNATIONAL MECHANICAL ELECTRICAL PLUMBING (IMEP) CODES AND ALL APPLICABLE LOCAL, STATE AND FEDERAL REGULATIONS.

KEYED NOTE LEGEND

- 1. MESSAGING SYSTEMS SHALL BE INSTALLED IN ACCORDANCE WITH THE LATEST EDITIONS OF THE INTERNATIONAL MECHANICAL ELECTRICAL PLUMBING (IMEP) CODES AND ALL APPLICABLE LOCAL, STATE AND FEDERAL REGULATIONS.
- 2. ALL WORK SHALL BE IN ACCORDANCE WITH THE LATEST EDITIONS OF THE INTERNATIONAL MECHANICAL ELECTRICAL PLUMBING (IMEP) CODES AND ALL APPLICABLE LOCAL, STATE AND FEDERAL REGULATIONS.
- 3. ALL WORK SHALL BE IN ACCORDANCE WITH THE LATEST EDITIONS OF THE INTERNATIONAL MECHANICAL ELECTRICAL PLUMBING (IMEP) CODES AND ALL APPLICABLE LOCAL, STATE AND FEDERAL REGULATIONS.
- 4. ALL WORK SHALL BE IN ACCORDANCE WITH THE LATEST EDITIONS OF THE INTERNATIONAL MECHANICAL ELECTRICAL PLUMBING (IMEP) CODES AND ALL APPLICABLE LOCAL, STATE AND FEDERAL REGULATIONS.
- 5. ALL WORK SHALL BE IN ACCORDANCE WITH THE LATEST EDITIONS OF THE INTERNATIONAL MECHANICAL ELECTRICAL PLUMBING (IMEP) CODES AND ALL APPLICABLE LOCAL, STATE AND FEDERAL REGULATIONS.
- 6. ALL WORK SHALL BE IN ACCORDANCE WITH THE LATEST EDITIONS OF THE INTERNATIONAL MECHANICAL ELECTRICAL PLUMBING (IMEP) CODES AND ALL APPLICABLE LOCAL, STATE AND FEDERAL REGULATIONS.
- 7. ALL WORK SHALL BE IN ACCORDANCE WITH THE LATEST EDITIONS OF THE INTERNATIONAL MECHANICAL ELECTRICAL PLUMBING (IMEP) CODES AND ALL APPLICABLE LOCAL, STATE AND FEDERAL REGULATIONS.
- 8. ALL WORK SHALL BE IN ACCORDANCE WITH THE LATEST EDITIONS OF THE INTERNATIONAL MECHANICAL ELECTRICAL PLUMBING (IMEP) CODES AND ALL APPLICABLE LOCAL, STATE AND FEDERAL REGULATIONS.
- 9. ALL WORK SHALL BE IN ACCORDANCE WITH THE LATEST EDITIONS OF THE INTERNATIONAL MECHANICAL ELECTRICAL PLUMBING (IMEP) CODES AND ALL APPLICABLE LOCAL, STATE AND FEDERAL REGULATIONS.
- 10. ALL WORK SHALL BE IN ACCORDANCE WITH THE LATEST EDITIONS OF THE INTERNATIONAL MECHANICAL ELECTRICAL PLUMBING (IMEP) CODES AND ALL APPLICABLE LOCAL, STATE AND FEDERAL REGULATIONS.

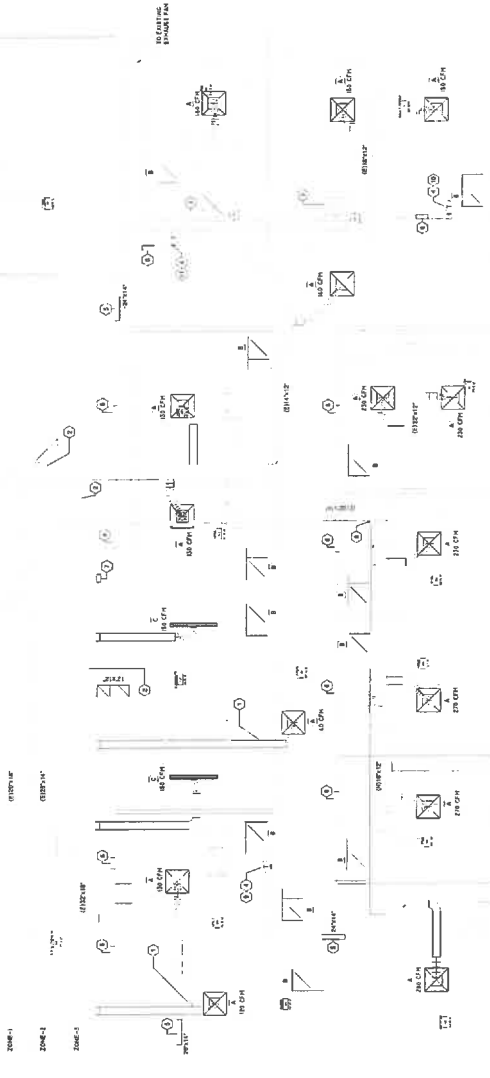

1 ENLARGED FLOOR PLAN - PROPOSED - HVAC
 Scale: 1/4" = 1'-0"



CLERM
 MERRILL HENRY COURT
 Galveston, Texas
 T Phone
 F Fax
 ARCHITECT



PG&AL, Inc.
 3531 S. Bayport, LN.
 Houston, TX 77058
 T 713 865-2444
 F 713 865-1444
 www.pgandal.com

CONSULTANT
 TRANSPORTATION ASSOCIATES
 11111 N. FORT WORTH AVENUE, SUITE 100
 FORT WORTH, TEXAS 76177
 T 817 335-7777
 F 817 335-7777
 www.transportation.com



REGISTERED PROFESSIONAL ENGINEER
 MECHANICAL
 NO. 17133
 STATE OF TEXAS
 EXPIRES 12/31/2007
 DRAWING HISTORY
 1 - ORIGINAL
 2 - REVISION

PROJECT NAME
 MERRILL HENRY COURT
 MENTAL HEALTH COURT
 RENOVATION

PROJECT LOCATION
 6000 West Loop, Suite 600
 Fort Worth, Texas 76102

PROJECT NUMBER
 1005437.00

SHEET TITLE
 DETAILS

SHEET NUMBER
 M3.01

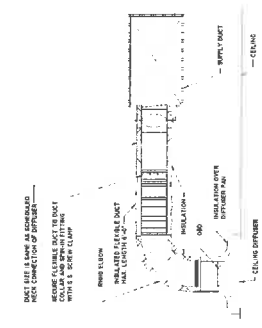

NOTE: REFER TO M3.01 FOR THE MOUNTING DETAIL OF THE DIFFUSER. THE DIFFUSER SHALL BE MOUNTED TO THE CEILING STRUCTURE. THE DIFFUSER SHALL BE MOUNTED TO THE CEILING STRUCTURE. THE DIFFUSER SHALL BE MOUNTED TO THE CEILING STRUCTURE.

4. CEILING DIFFUSER CONNECTION DETAIL

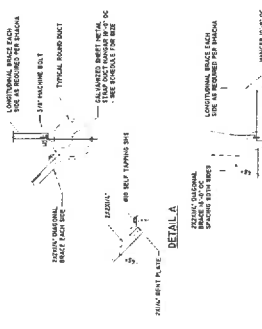

NOTE: REFER TO M3.01 FOR THE MOUNTING DETAIL OF THE DUCT. THE DUCT SHALL BE MOUNTED TO THE CEILING STRUCTURE. THE DUCT SHALL BE MOUNTED TO THE CEILING STRUCTURE. THE DUCT SHALL BE MOUNTED TO THE CEILING STRUCTURE.

6. DUCT SUPPORT DETAIL

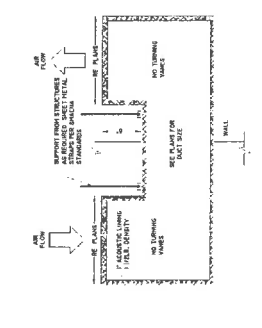

NOTE: 1. RETURN AIR BOOT WITH TWO ELBOWS.
 2. RETURN AIR BOOT WITH TWO ELBOWS.
 3. RETURN AIR BOOT WITH TWO ELBOWS.

1. RETURN AIR BOOT WITH TWO ELBOWS

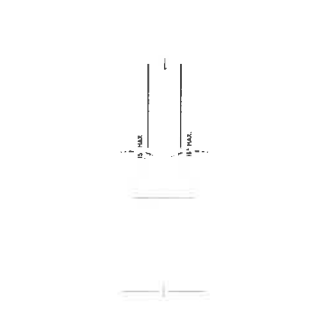

NOTE: SEE FLOOR PLANS FOR CONNECTIONS.
 1. TURNING VANES
 2. TURNING VANES
 3. TURNING VANES
 4. TURNING VANES
 5. TURNING VANES
 6. TURNING VANES
 7. TURNING VANES
 8. TURNING VANES
 9. TURNING VANES
 10. TURNING VANES
 11. TURNING VANES
 12. TURNING VANES
 13. TURNING VANES
 14. TURNING VANES
 15. TURNING VANES
 16. TURNING VANES
 17. TURNING VANES
 18. TURNING VANES
 19. TURNING VANES
 20. TURNING VANES
 21. TURNING VANES
 22. TURNING VANES
 23. TURNING VANES
 24. TURNING VANES
 25. TURNING VANES
 26. TURNING VANES
 27. TURNING VANES
 28. TURNING VANES
 29. TURNING VANES
 30. TURNING VANES
 31. TURNING VANES
 32. TURNING VANES
 33. TURNING VANES
 34. TURNING VANES
 35. TURNING VANES
 36. TURNING VANES
 37. TURNING VANES
 38. TURNING VANES
 39. TURNING VANES
 40. TURNING VANES
 41. TURNING VANES
 42. TURNING VANES
 43. TURNING VANES
 44. TURNING VANES
 45. TURNING VANES
 46. TURNING VANES
 47. TURNING VANES
 48. TURNING VANES
 49. TURNING VANES
 50. TURNING VANES
 51. TURNING VANES
 52. TURNING VANES
 53. TURNING VANES
 54. TURNING VANES
 55. TURNING VANES
 56. TURNING VANES
 57. TURNING VANES
 58. TURNING VANES
 59. TURNING VANES
 60. TURNING VANES
 61. TURNING VANES
 62. TURNING VANES
 63. TURNING VANES
 64. TURNING VANES
 65. TURNING VANES
 66. TURNING VANES
 67. TURNING VANES
 68. TURNING VANES
 69. TURNING VANES
 70. TURNING VANES
 71. TURNING VANES
 72. TURNING VANES
 73. TURNING VANES
 74. TURNING VANES
 75. TURNING VANES
 76. TURNING VANES
 77. TURNING VANES
 78. TURNING VANES
 79. TURNING VANES
 80. TURNING VANES
 81. TURNING VANES
 82. TURNING VANES
 83. TURNING VANES
 84. TURNING VANES
 85. TURNING VANES
 86. TURNING VANES
 87. TURNING VANES
 88. TURNING VANES
 89. TURNING VANES
 90. TURNING VANES
 91. TURNING VANES
 92. TURNING VANES
 93. TURNING VANES
 94. TURNING VANES
 95. TURNING VANES
 96. TURNING VANES
 97. TURNING VANES
 98. TURNING VANES
 99. TURNING VANES
 100. TURNING VANES

5. DUCTWORK FITTINGS DETAIL

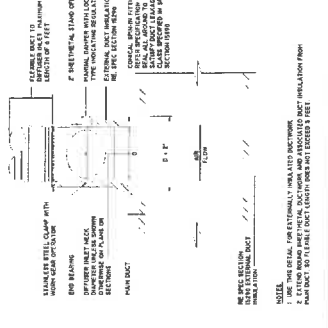

NOTE: 1. REFER TO DRAWINGS AND AIR SERVICE SCHEDULE FOR ADDITIONAL REQUIREMENTS.
 2. REFER TO DRAWINGS AND AIR SERVICE SCHEDULE FOR ADDITIONAL REQUIREMENTS.
 3. REFER TO DRAWINGS AND AIR SERVICE SCHEDULE FOR ADDITIONAL REQUIREMENTS.

7. SPIN FITTING DETAIL



NOTE: 1. REFER TO DRAWINGS AND AIR SERVICE SCHEDULE FOR ADDITIONAL REQUIREMENTS.
 2. REFER TO DRAWINGS AND AIR SERVICE SCHEDULE FOR ADDITIONAL REQUIREMENTS.
 3. REFER TO DRAWINGS AND AIR SERVICE SCHEDULE FOR ADDITIONAL REQUIREMENTS.

1. RETURN AIR BOOT WITH TWO ELBOWS

DATE STAMP: 5/24/2021 4:34:43 PM
 NAME: C:\Users\merrillh@comcast.net\Documents\Projects\Mental Health Court\T3_10315HW\T3_10315HW.rvt

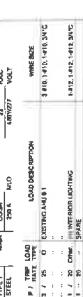

TYPE	AMOUNT	LOAD TYPE	REMARKS
RESISTANCE HEATING
COOLING
VENTILATION
POWER
TOTAL

ELECTRICAL LOAD ANALYSIS
 PROJECT: GALVESTON MENTAL HEALTH CT. TOTAL AREA: 27387 SF
 1. DESIGNER'S RESPONSIBILITIES
 2. SYSTEMS TO BE PROVIDED
 3. DESIGNER'S ASSUMPTIONS
 4. DESIGNER'S COMMENTS

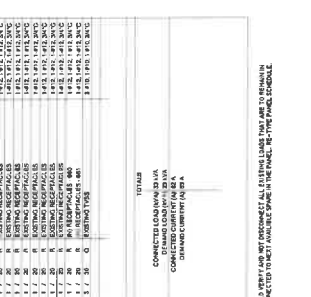

ELECTRICAL LOAD ANALYSIS

TYPE	AMOUNT	LOAD TYPE	REMARKS
RESISTANCE HEATING
COOLING
VENTILATION
POWER
TOTAL

EXISTING PANEL SCHEDULE

PANEL NO.	PANEL TYPE	VOLTS	CIRCUITS
...

PANEL: 69A
 LOCATION: ELEC ROOM

CIRCUIT	TYPE	LOAD	REMARKS
...

PANEL: 69A

CIRCUIT	TYPE	LOAD	REMARKS
...

ELECTRICAL LOAD ANALYSIS

TYPE	AMOUNT	LOAD TYPE	REMARKS
RESISTANCE HEATING
COOLING
VENTILATION
POWER
TOTAL

FIRE ALARM SYSTEM DIAGRAM
 Shows fire alarm system components, including detectors, control panel, and notification appliances.

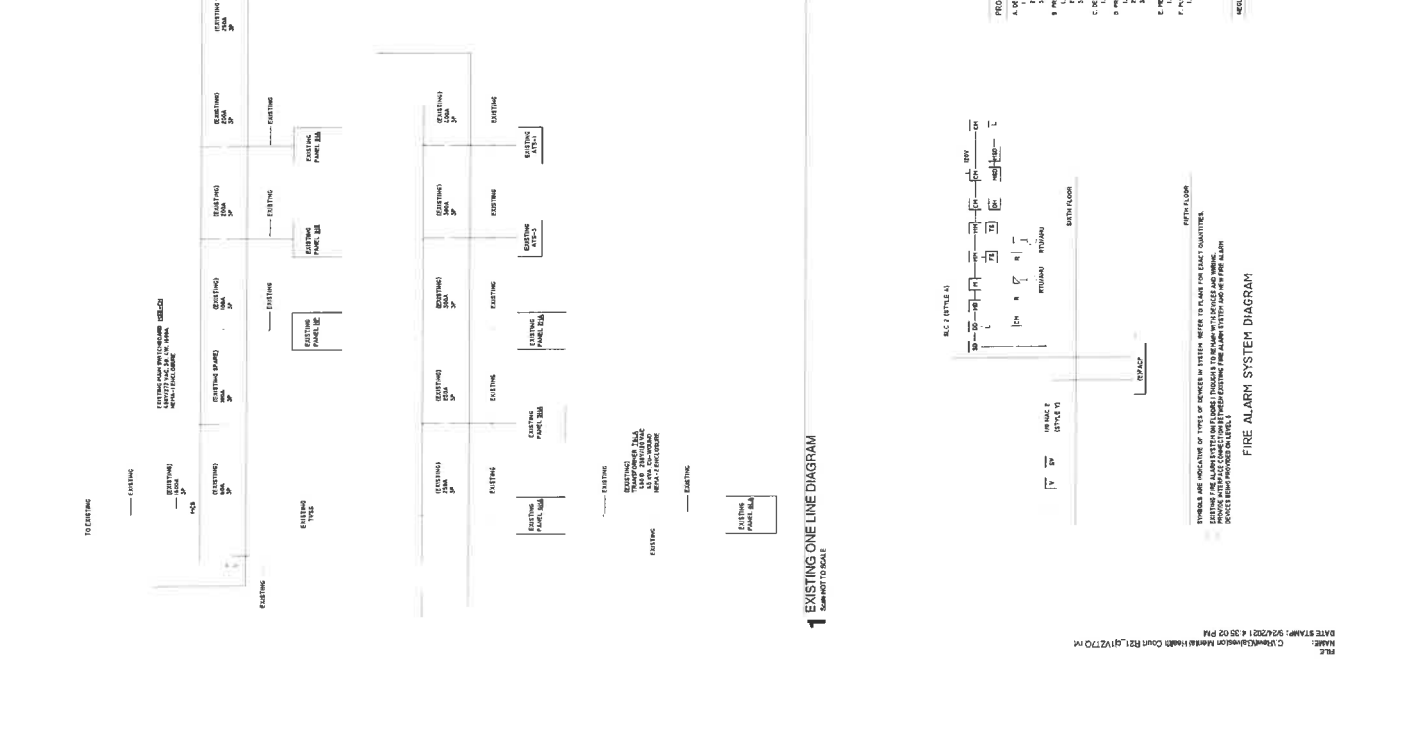



CLINIC
 Mental Health Court
 Galveston, Texas
 T Phone
 F Fax
 ARCHITECT



PGAL, Inc.
 3131 Seawall Dr.
 Houston, TX 77054
 P 713 822 1144
 www.pgal.com



WINTERS ASSOCIATES, INC.
 1401 WEST 15TH STREET, SUITE 200
 HOUSTON, TEXAS 77057
 P 713 865 1144
 WWW.WINTERSASSOCIATES.COM



REGISTRATION
 CONTRACT
 DRAWING HISTORY

PROJECT NAME
 GALVESTON
 MENTAL
 HEALTH COURT
 RENOVATION

PROJECT LOCATION
 2200 Seawall, Bldg
 Floor Galveston,
 Texas 77550

PROJECT NUMBER
 1005437.00

SHEET TITLE
 OVERALL FLOOR
 PLAN - PROPOSED -
 ELECTRICAL

SHEET NUMBER
 E2.01

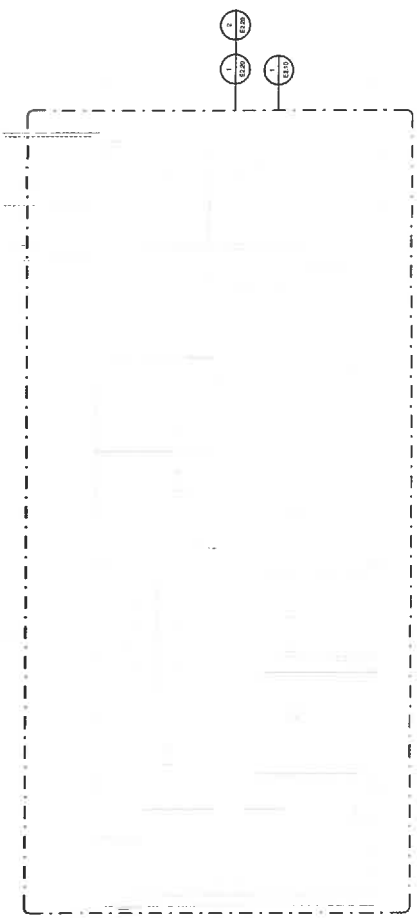

1 OVERALL SIXTH LEVEL FLOOR PLAN - PROPOSED - POWER
 Date: 08/22/09



Client
Galveston County Health Department
Galveston, Texas

Project Name
Galveston County Health Department
Renovation



PG&AL, Inc.
13111 West Loop South
Suite 200
Houston, Texas 77036
P: 713.862.1444
www.pgandal.com



Contractor
Galveston County Health Department
Renovation



Project Name
Galveston County Health Department
Renovation

Project Location
722 Wood Avenue, 8th Floor
Galveston, Texas 77550

Project Number
1005437.00

Sheet Title
ENLARGED FLOOR PLAN - DEMOLITION - ELECTRICAL

Sheet Number
E2.10

ELECTRICAL GENERAL DEMOLITION NOTES

1. REMOVE ALL EXISTING ELECTRICAL DEVICES AND DEVICES IN THE SCOPE OF THIS PROJECT. REMOVE ALL EXISTING ELECTRICAL DEVICES AND DEVICES IN THE SCOPE OF THIS PROJECT. REMOVE ALL EXISTING ELECTRICAL DEVICES AND DEVICES IN THE SCOPE OF THIS PROJECT.
2. REMOVE ALL EXISTING ELECTRICAL DEVICES AND DEVICES IN THE SCOPE OF THIS PROJECT. REMOVE ALL EXISTING ELECTRICAL DEVICES AND DEVICES IN THE SCOPE OF THIS PROJECT. REMOVE ALL EXISTING ELECTRICAL DEVICES AND DEVICES IN THE SCOPE OF THIS PROJECT.
3. REMOVE ALL EXISTING ELECTRICAL DEVICES AND DEVICES IN THE SCOPE OF THIS PROJECT. REMOVE ALL EXISTING ELECTRICAL DEVICES AND DEVICES IN THE SCOPE OF THIS PROJECT. REMOVE ALL EXISTING ELECTRICAL DEVICES AND DEVICES IN THE SCOPE OF THIS PROJECT.
4. REMOVE ALL EXISTING ELECTRICAL DEVICES AND DEVICES IN THE SCOPE OF THIS PROJECT. REMOVE ALL EXISTING ELECTRICAL DEVICES AND DEVICES IN THE SCOPE OF THIS PROJECT. REMOVE ALL EXISTING ELECTRICAL DEVICES AND DEVICES IN THE SCOPE OF THIS PROJECT.
5. REMOVE ALL EXISTING ELECTRICAL DEVICES AND DEVICES IN THE SCOPE OF THIS PROJECT. REMOVE ALL EXISTING ELECTRICAL DEVICES AND DEVICES IN THE SCOPE OF THIS PROJECT. REMOVE ALL EXISTING ELECTRICAL DEVICES AND DEVICES IN THE SCOPE OF THIS PROJECT.
6. REMOVE ALL EXISTING ELECTRICAL DEVICES AND DEVICES IN THE SCOPE OF THIS PROJECT. REMOVE ALL EXISTING ELECTRICAL DEVICES AND DEVICES IN THE SCOPE OF THIS PROJECT. REMOVE ALL EXISTING ELECTRICAL DEVICES AND DEVICES IN THE SCOPE OF THIS PROJECT.
7. REMOVE ALL EXISTING ELECTRICAL DEVICES AND DEVICES IN THE SCOPE OF THIS PROJECT. REMOVE ALL EXISTING ELECTRICAL DEVICES AND DEVICES IN THE SCOPE OF THIS PROJECT. REMOVE ALL EXISTING ELECTRICAL DEVICES AND DEVICES IN THE SCOPE OF THIS PROJECT.
8. REMOVE ALL EXISTING ELECTRICAL DEVICES AND DEVICES IN THE SCOPE OF THIS PROJECT. REMOVE ALL EXISTING ELECTRICAL DEVICES AND DEVICES IN THE SCOPE OF THIS PROJECT. REMOVE ALL EXISTING ELECTRICAL DEVICES AND DEVICES IN THE SCOPE OF THIS PROJECT.
9. REMOVE ALL EXISTING ELECTRICAL DEVICES AND DEVICES IN THE SCOPE OF THIS PROJECT. REMOVE ALL EXISTING ELECTRICAL DEVICES AND DEVICES IN THE SCOPE OF THIS PROJECT. REMOVE ALL EXISTING ELECTRICAL DEVICES AND DEVICES IN THE SCOPE OF THIS PROJECT.
10. REMOVE ALL EXISTING ELECTRICAL DEVICES AND DEVICES IN THE SCOPE OF THIS PROJECT. REMOVE ALL EXISTING ELECTRICAL DEVICES AND DEVICES IN THE SCOPE OF THIS PROJECT. REMOVE ALL EXISTING ELECTRICAL DEVICES AND DEVICES IN THE SCOPE OF THIS PROJECT.

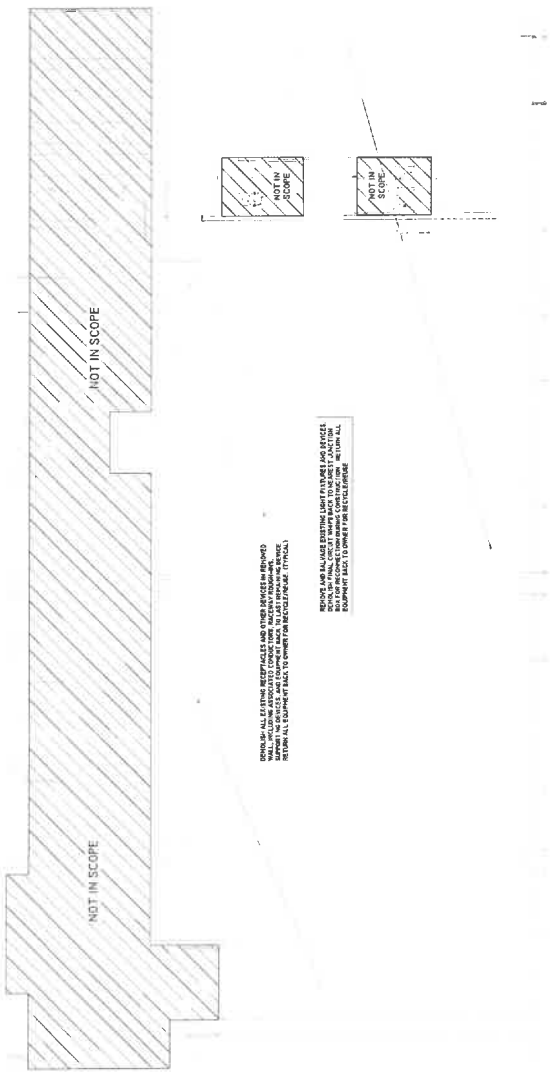

1 ENLARGED FLOOR PLAN - DEMOLITION - ELECTRICAL
Scale: 1/8" = 1'-0"



CLIENT
 Mental Health Court
 Galveston, Texas
 T. Phyllis
 F. Far



PGAL, Inc.
 3031 Bergmark Dr.
 Houston, TX 77042
 P 713 852 1444
 www.pgal.com

CONSULTANT
**MINSHAW
 PARTNERS**
 ASSOCIATES
 11000 Katy Road, Suite 400
 Houston, Texas 77058
 P 281 460 4400
 www.minshaw.com



PROJECT NUMBER
 201700007
 DRAWING HISTORY
 1 REVISION: 08/20/2017

PROJECT NAME
 GULFSTON
 COUNTY
 MENTAL
 HEALTH COURT
 RENOVATION
 PROJECT LOCATION
 7700 West Loop South, 6th
 Floor, Galveston, TX
 Texas 77550
 PROJECT NUMBER
 1005437.00

SHEET TITLE
 ENLARGED FLOOR
 PLAN - POWER
 ELECTRICAL

SHEET NUMBER
E2.20

KEYED NOTE LEGEND

1. ALL WORK SHALL BE IN ACCORDANCE WITH THE LATEST EDITIONS OF THE NATIONAL ELECTRICAL CODE (NEC) AND THE NATIONAL FIRE ALARM AND SIGNALING CODE (NFPA 72).

UNAVAILABLE FROM JAMES HENNINGSEN/PGAL
 THE INFORMATION CONTAINED HEREIN IS THE PROPERTY OF PGAL, INC. AND IS TO BE USED ONLY FOR THE PROJECT AND SITE SPECIFICALLY IDENTIFIED IN THE TITLE OF THIS DRAWING. IT IS NOT TO BE REPRODUCED, COPIED, OR TRANSMITTED IN ANY FORM OR BY ANY MEANS, ELECTRONIC OR MECHANICAL, INCLUDING PHOTOCOPYING, RECORDING, OR BY ANY INFORMATION STORAGE AND RETRIEVAL SYSTEM, WITHOUT THE WRITTEN PERMISSION OF PGAL, INC. ANY REPRODUCTION, COPIING, OR TRANSMISSION OF THIS DRAWING WITHOUT THE WRITTEN PERMISSION OF PGAL, INC. SHALL BE CONSIDERED A VIOLATION OF THE COPYRIGHT LAWS OF THE UNITED STATES OF AMERICA AND WILL BE PROSECUTED TO THE FULL EXTENT OF THE LAW.

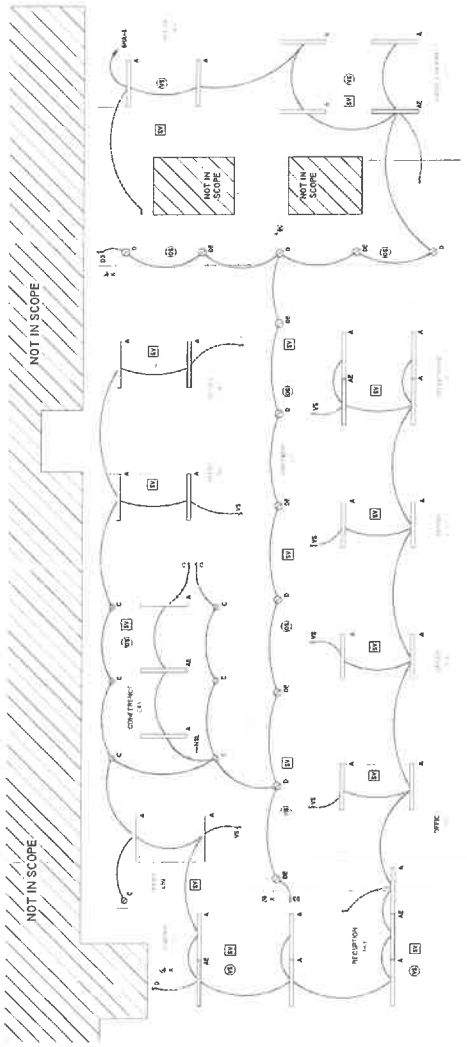

2 ENLARGED FLOOR PLAN - PROPOSED - POWER

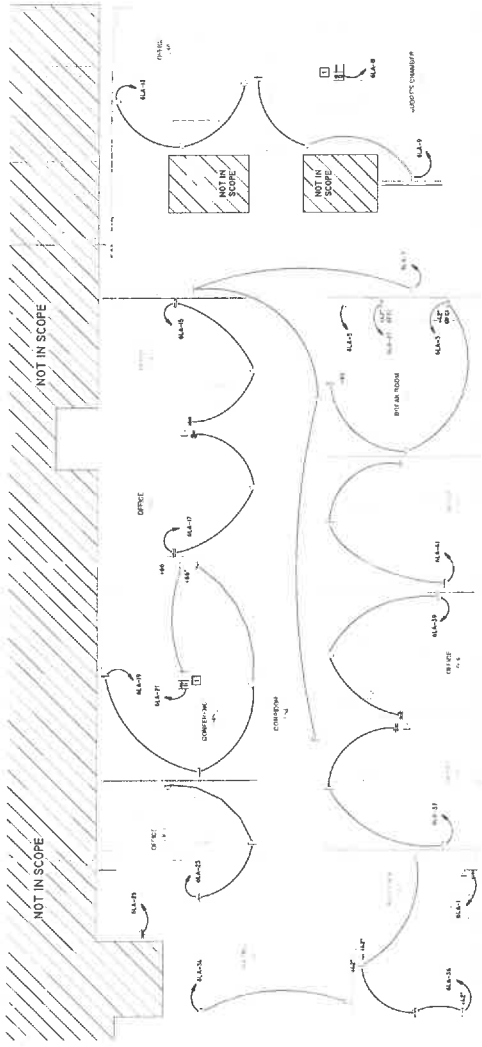

1 ENLARGED FLOOR PLAN - PROPOSED - POWER



CLIENT
TRUSTEES OF TEXAS HEALTH SERVICES
 Galveston, Texas
 T. Phone
 F. Fax
 MCHS1217



PG&AL, Inc.
 5131 Sistrup Dr.
 Houston, TX 77042
 P 713 825 1444
 F 713 825 1444
 www.pgandal.com

COMPETENT NAME
INDUSTRIAL ASSOCIATES
 MANUFACTURING ASSOCIATES, INC.
 14000 W. FORT WORTH BLVD., SUITE 900
 FORT WORTH, TEXAS 76150
 P 817 835 6200
 WWW.MANUFACTURING.COM

REGISTRATION
 Certified Engineer
 State of Texas
 No. 12345
 Exp. 12/31/2024



DRAWING HISTORY

NO.	DATE	DESCRIPTION

PROJECT NAME
GALVESTON COUNTY HEALTH COURT RENOVATION
 PROJECT LOCATION
 722 MCGUIRE AVENUE, 6TH FLOOR
 GALVESTON, TEXAS 77555
 PROJECT NUMBER
 1005437.00

SHEET TITLE
FIRE PROTECTION PLAN

SHEET NUMBER
FP1.01

FIRE PROTECTION NOTES

- CONTRACTOR SHALL REVIEW THE LOCAL CODES AND REGULATIONS APPLICABLE TO THE TYPE OF LOCAL JURISDICTION. THE CONTRACTOR SHALL VERIFY THE LOCAL CODES AND REGULATIONS WITH THE LOCAL JURISDICTION. THE CONTRACTOR SHALL VERIFY THE LOCAL CODES AND REGULATIONS WITH THE LOCAL JURISDICTION. THE CONTRACTOR SHALL VERIFY THE LOCAL CODES AND REGULATIONS WITH THE LOCAL JURISDICTION.
- VERIFY ALL MATERIALS AND METHODS OF INSTALLATION ARE APPROVED BY THE LOCAL JURISDICTION. THE CONTRACTOR SHALL VERIFY THE LOCAL CODES AND REGULATIONS WITH THE LOCAL JURISDICTION. THE CONTRACTOR SHALL VERIFY THE LOCAL CODES AND REGULATIONS WITH THE LOCAL JURISDICTION.
- VERIFY ALL MATERIALS AND METHODS OF INSTALLATION ARE APPROVED BY THE LOCAL JURISDICTION. THE CONTRACTOR SHALL VERIFY THE LOCAL CODES AND REGULATIONS WITH THE LOCAL JURISDICTION. THE CONTRACTOR SHALL VERIFY THE LOCAL CODES AND REGULATIONS WITH THE LOCAL JURISDICTION.
- VERIFY ALL MATERIALS AND METHODS OF INSTALLATION ARE APPROVED BY THE LOCAL JURISDICTION. THE CONTRACTOR SHALL VERIFY THE LOCAL CODES AND REGULATIONS WITH THE LOCAL JURISDICTION. THE CONTRACTOR SHALL VERIFY THE LOCAL CODES AND REGULATIONS WITH THE LOCAL JURISDICTION.
- VERIFY ALL MATERIALS AND METHODS OF INSTALLATION ARE APPROVED BY THE LOCAL JURISDICTION. THE CONTRACTOR SHALL VERIFY THE LOCAL CODES AND REGULATIONS WITH THE LOCAL JURISDICTION. THE CONTRACTOR SHALL VERIFY THE LOCAL CODES AND REGULATIONS WITH THE LOCAL JURISDICTION.
- VERIFY ALL MATERIALS AND METHODS OF INSTALLATION ARE APPROVED BY THE LOCAL JURISDICTION. THE CONTRACTOR SHALL VERIFY THE LOCAL CODES AND REGULATIONS WITH THE LOCAL JURISDICTION. THE CONTRACTOR SHALL VERIFY THE LOCAL CODES AND REGULATIONS WITH THE LOCAL JURISDICTION.
- VERIFY ALL MATERIALS AND METHODS OF INSTALLATION ARE APPROVED BY THE LOCAL JURISDICTION. THE CONTRACTOR SHALL VERIFY THE LOCAL CODES AND REGULATIONS WITH THE LOCAL JURISDICTION. THE CONTRACTOR SHALL VERIFY THE LOCAL CODES AND REGULATIONS WITH THE LOCAL JURISDICTION.

FIRE PROTECTION GENERAL NOTES
 ALL WORK SHALL BE IN ACCORDANCE WITH THE LOCAL CODES AND REGULATIONS. THE CONTRACTOR SHALL VERIFY THE LOCAL CODES AND REGULATIONS WITH THE LOCAL JURISDICTION. THE CONTRACTOR SHALL VERIFY THE LOCAL CODES AND REGULATIONS WITH THE LOCAL JURISDICTION.

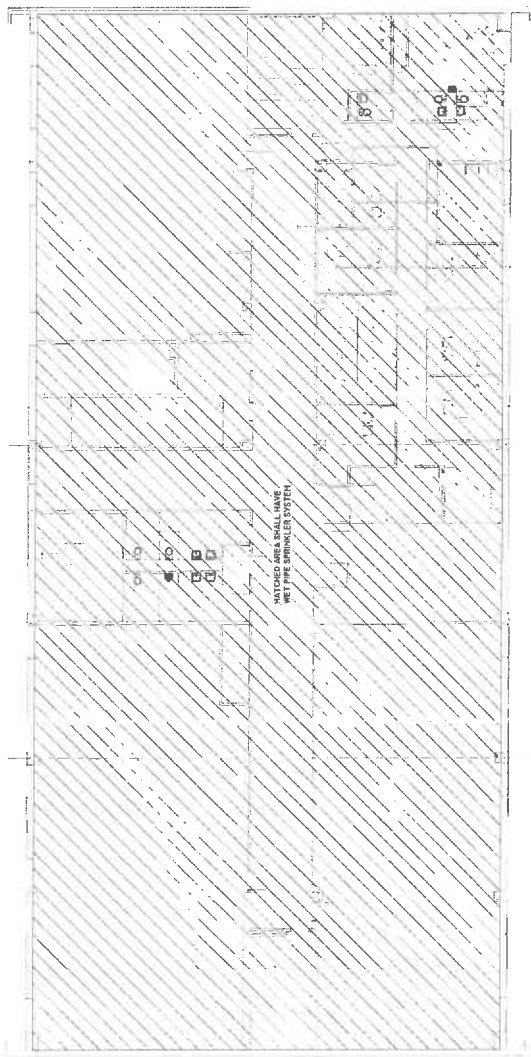

OVERALL SIXTH LEVEL FLOOR PLAN - PROPOSED
1
 PLUMBING
 Date: 10/1/20

PLUMBING LEGEND & ABBREVIATIONS

Table with columns for symbols and their meanings: PIPING, VALVES, FITTINGS, and ELECTRICAL.

PLUMBING FIXTURE SCHEDULE

Table with columns: MARK, DESCRIPTION, SIZE OF CONNECTION, and REMARKS.

PIPING MATERIALS

- List of piping materials including galvanized steel pipe, black steel pipe, and various fittings.

GENERAL NOTES

- Series of 14 numbered notes detailing installation requirements, material specifications, and labor standards.



CLIENT: Mental Health Court
Project: Texas



PG&AL
3131 Hempden Dr
Houston, TX 77042



Inhabitation ASSOCIATES INC
11725 Katy Road
Houston, TX 77058



REGISTRATION NO. 13138
Greg A. Smith
Professional Engineer
State of Texas

Table with columns: SHEET NUMBER, DATE, and DRAWING HISTORY.



CLIENT
 Mental Health Court
 Galveston, Texas
 T. Phone
 F. Fax



ARCHITECT
 PCAL, Inc.
 3101 Starwood Dr.
 Houston, TX 77062
 T. 281.412.1444
 F. 281.412.1444
 www.pcal.com

CONSULTANT
 MANUFACTURING EXPERTS INC
 11000 FARM ROAD 1900E SUITE 500
 HOUSTON, TEXAS 77036
 T. 281.412.1444
 F. 281.412.1444
 WWW.MANUFACTURINGEXPERTS.COM



REGISTERED PROFESSIONAL ENGINEER
 License No. 11818
 State of Texas
 08/15/2017
 DRAWING HISTORY
 1. 281.412.1444
 2. 281.412.1444

PROJECT NAME
 GALVESTON
 COUNTY
 MENTAL
 HEALTH COURT
 RENOVATION

PROJECT LOCATION
 7000 Starwood Dr., 6th
 Floor Galveston,
 Texas 77550

PROJECT NUMBER
 1005437.00

SHEET TITLE
 OVERALL FLOOR
 PLAN - PLUMBING

SHEET NUMBER
 P2.01

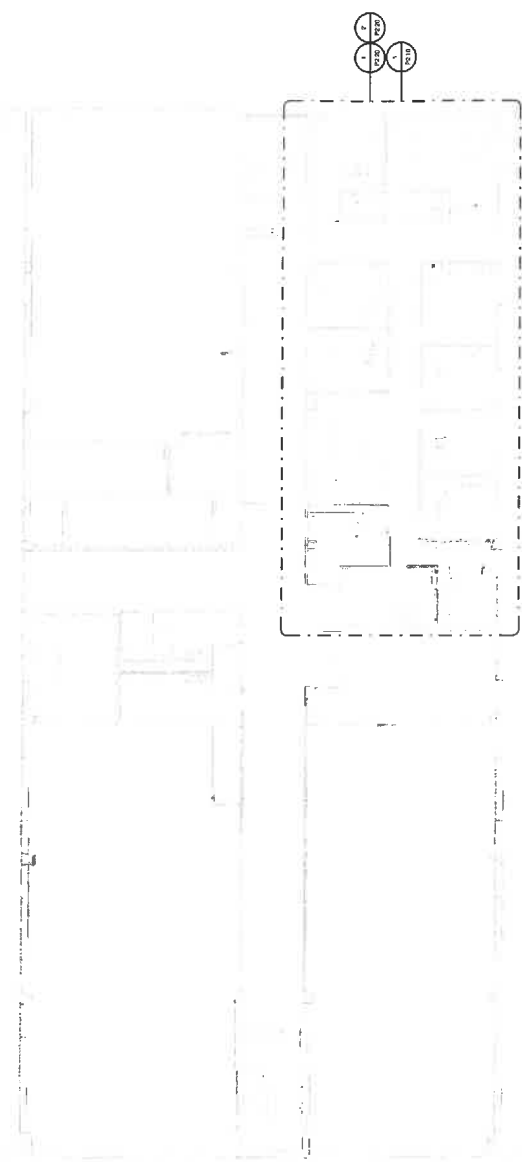

OVERALL SIXTH LEVEL FLOOR PLAN - PROPOSED -
 PLUMBING
 1
 Scale: 1/8" = 1'-0"



PLUMBING GENERAL DEMOLITION NOTES

1. REMOVE ALL EXISTING FLOOR FINISH (CARPETING, FLOOR LAMINATE, ETC.) SHALL BE REPOSEMENTED TO ORIGINAL CONDITION.
2. REMOVE ALL EXISTING PLUMBING AND ELECTRICAL SYSTEMS TO BE DEMOLISHED.
3. ALL EXISTING PLUMBING SHALL BE DEMOLISHED AND DISPOSED OF AT THE APPROPRIATE LOCATION.
4. ALL EXISTING ELECTRICAL SHALL BE DEMOLISHED AND DISPOSED OF AT THE APPROPRIATE LOCATION.

KEYED NOTE LEGEND

1. REMOVE EXISTING PLUMBING SYSTEMS AT THIS LOCATION AND ASSOCIATED PIPING. REMOVE WOOD WALLS, SHEET ROOFING AND ASSOCIATED TRUSS SYSTEMS TO BE DEMOLISHED AND DISPOSED OF AT THE APPROPRIATE LOCATION. SEE SHEET 02 FOR EXISTING PLUMBING SYSTEMS.

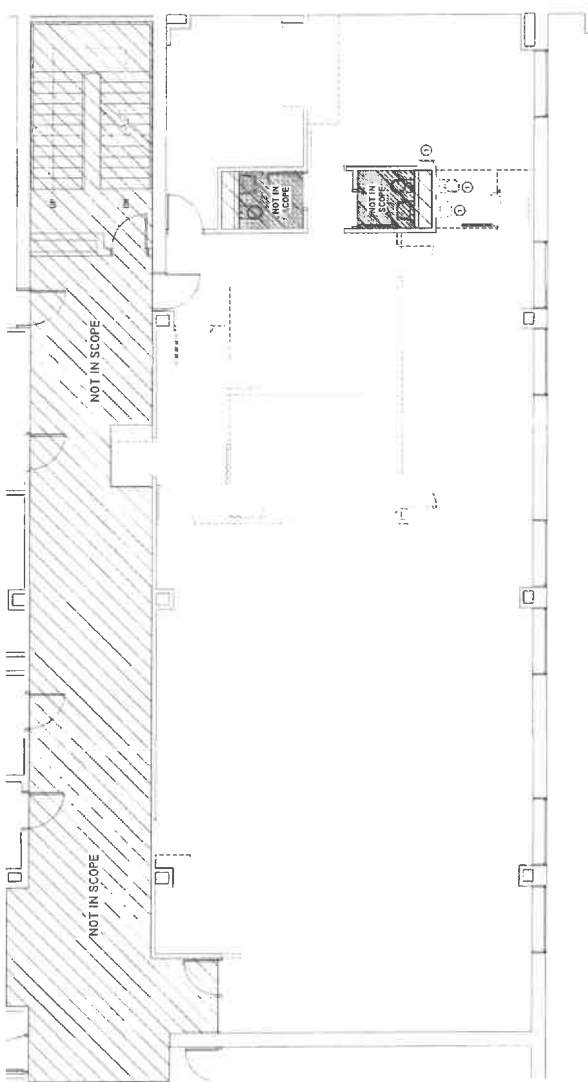

1 ENLARGED GROUND LEVEL FLOOR PLAN - DEMOLITION - SANITARY & DOMESTIC
Scale: 1/8" = 1'-0"



CLIENT
Mental Health Court
Galveston, Texas

T. P. PUGH
P.E.



PCAL, INC.
1100 Westpark Dr.
Suite 200
Houston, TX 77062
P: 713.852.1442
F: 713.852.1444
www.pcal.com

COMMISSIONER
INTERNATIONAL ASSOCIATION
OF PLUMBERS AND PIPEFITTERS
LOCAL 139
1100 Westpark Dr.
Suite 200
Houston, TX 77062
P: 713.852.1442
F: 713.852.1444
www.iapf.com



REVISIONS
Contract # 2018
21183
2021.09.27

DRAWING HISTORY

NO.	DATE	DESCRIPTION
1	09/27/21	ISSUED FOR PERMIT

PROJECT NAME
GALVESTON
COUNTY
MENTAL
HEALTH COURT
RENOVATION

PROJECT LOCATION
722 Maged Avenue, 6th
Floor, Galveston,
Texas 77550

PROJECT NUMBER
1005437.00

SHEET TITLE
PLUMBING FLOOR
PLAN - PLUMBING

SHEET NUMBER
P.2.20

PLUMBING GENERAL NOTES

1. THIS PLAN IS A SUPPLEMENT TO THE PLUMBING CONTRACT AND SHALL BE READ IN CONJUNCTION WITH THE CONTRACT. ANY CONFLICTS SHALL BE RESOLVED BY THE CONTRACTOR.
2. ALL NUMBERS SHOWN SHALL BE SUBJECT TO CHANGE WITHOUT NOTICE.

KEYED NOTE LEGEND

1. ROUTE NEW SANITARY LINE TO EXISTING SANITARY LINE (REAR) AT EACH LOCATION. SIZE OF PIPELINE OF NEW SANITARY LINE SHALL BE AS SHOWN ON THIS PLAN.
2. ROUTE NEW WATER LINE TO EXISTING WATER LINE (REAR) AT EACH LOCATION. SIZE OF PIPELINE OF NEW WATER LINE SHALL BE AS SHOWN ON THIS PLAN.
3. EXISTING PIPELINE SHALL BE SUBJECT TO CHANGE WITHOUT NOTICE.

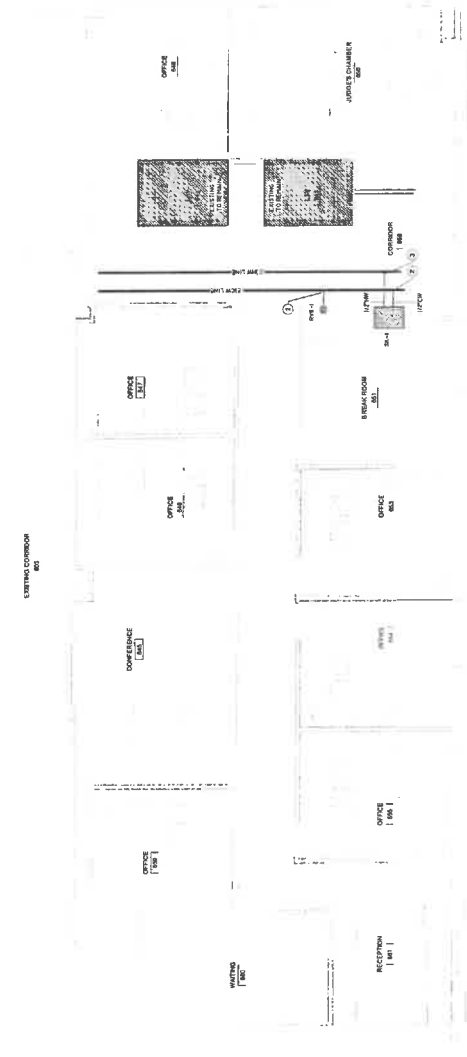

2 ENLARGED SIXTH LEVEL FLOOR PLAN - PROPOSED - DOMESTIC
Scale: 1/4" = 1'-0"

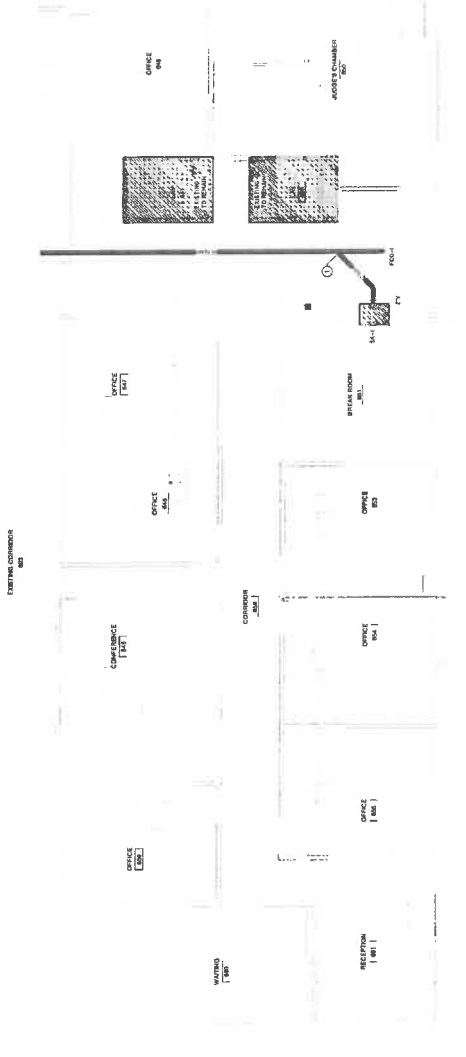

1 ENLARGED SIXTH LEVEL FLOOR PLAN - PROPOSED - SANITARY
Scale: 1/4" = 1'-0"



CLIENT
Mental Health Court
Galveston, Texas

PROJECT NAME
COUNTY
CITY
MENTAL
HEALTH COURT
RENOVATION

PROJECT LOCATION
7th Floor, Galveston, TX
Galveston, TX 77550

PROJECT NUMBER
1005437.00

SHEET TITLE
RISER DIAGRAMS

SHEET NUMBER
P4.01

KEYED NOTE LEGEND

- 1. ALL LOW VOLTAGE CABLES SHALL BE INSTALLED TO THE RIGHT OF THE CABLE TRAY.
- 2. ALL LOW VOLTAGE CABLES SHALL BE INSTALLED TO THE LEFT OF THE CABLE TRAY.
- 3. ALL LOW VOLTAGE CABLES SHALL BE INSTALLED TO THE RIGHT OF THE CABLE TRAY.
- 4. ALL LOW VOLTAGE CABLES SHALL BE INSTALLED TO THE LEFT OF THE CABLE TRAY.



PG&AL, Inc.
3031 Springdale Dr.
Houston, TX 77062
P: 713 882 1444
www.pgandal.com

CONSULTANT
MANUFACTURING ASSOCIATES, INC.
14000 NORTH FORT WORTH TRAIL
FARMERS BRANCH, TX 75438
P: 972 382 2200
www.manufact.com

REGISTERED PROFESSIONAL ENGINEER
No. 12193
Exp. 12/31/2021



DRAWING HISTORY
NO. DATE BY
1 01/15/2021 J. HESTON

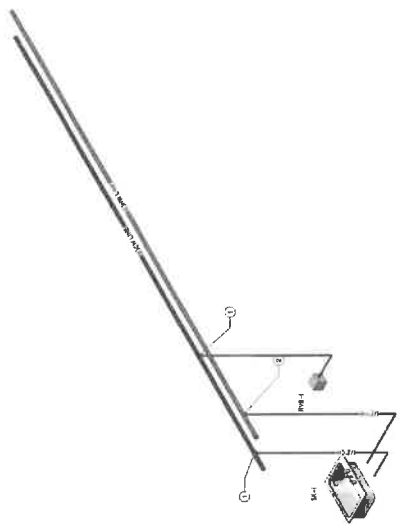

1 RISER DIAGRAM - PROPOSED - SANITARY

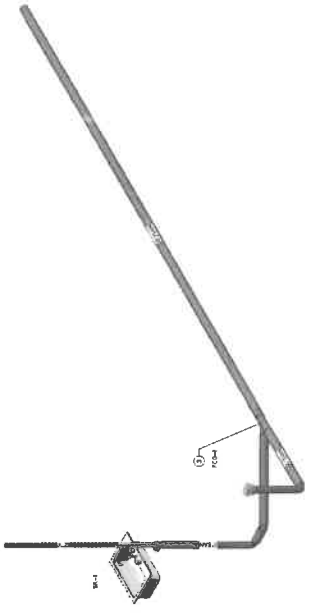

2 RISER DIAGRAM - PROPOSED - DOMESTIC

CLIENT



Marshall Health Court
Galveston, Texas

T Phone
F Fax

ARCHITECT



PG&AL, Inc.
3131 Seawalk Dr.
Houston, TX 77042
P 713 822-1444
F 713 822-1444
www.pgandal.com

CONSULTANT

ENGINEERING
ASSOCIATES
MECHANICAL AND PLUMBING
14000 N. FORT WORTH
AVENUE, SUITE 200
FORTH WORTH, TX 76101
P 817 342-1000
F 817 342-1000
WWW.MACKENGINEERS.COM

REGISTRATION



REGISTERED PROFESSIONAL ENGINEER
STATE OF TEXAS
NO. 10243
EXPIRES 12/31/2014

DRAWING HISTORY

NO.	DATE	DESCRIPTION
1	10/20/14	ISSUED FOR PERMITS

PROJECT NAME
GALVESTON
MARSHALL
HEALTH COURT
RENOVATION

PROJECT LOCATION
12200 N. FORT WORTH
AVENUE, FORTH WORTH,
TEXAS 77150

PROJECT NUMBER
1005437.00

SHEET TITLE
DETAILS

SHEET NUMBER
P5.01

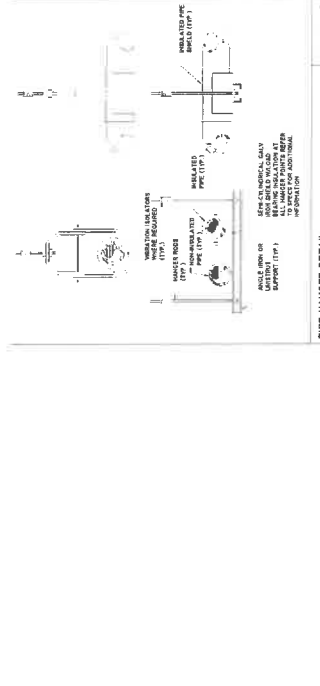

PIPE HANGER DETAIL REF TO SHEET 2

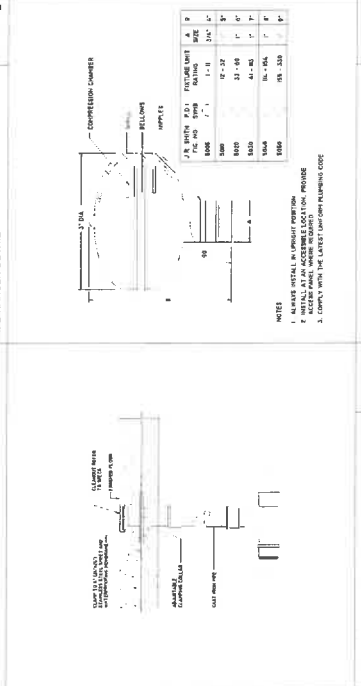

FLOOR CLEANOUT DETAIL (FCO-1) REF TO SHEET 3 WATER HAMMER ARRESTERS

J.P. BIRTH	REV.	DATE	DESCRIPTION
1006	1	02-27	REVISED PER COMMENTS
1006	2	01-28	REVISED PER COMMENTS
1006	3	01-28	REVISED PER COMMENTS
1006	4	01-28	REVISED PER COMMENTS
1006	5	01-28	REVISED PER COMMENTS
1006	6	01-28	REVISED PER COMMENTS

NOTES:
 1. VERIFY ALL MATERIALS TO BE INSTALLED AGAINST THE LATEST APPLICABLE NATIONAL PLUMBING CODE.
 2. VERIFY ALL MATERIALS TO BE INSTALLED AGAINST THE LATEST APPLICABLE NATIONAL PLUMBING CODE.
 3. VERIFY ALL MATERIALS TO BE INSTALLED AGAINST THE LATEST APPLICABLE NATIONAL PLUMBING CODE.